

Vitotronic 200

Type WO1C

Heat pump control unit

- For air/water heat pumps with indoor and outdoor units, split or monoblock version: Vitocal 100-S/111-S, Vitocal 200-A/222-A, Vitocal 200-S/222-S
- For air/water heat pumps for indoor/outdoor installation, monoblock version: Vitocal 200-A, Vitocal 300-A, type AWO-AC 301.B and AWO 302.B
- For compact brine/water heat pumps: Vitocal 222-G, Vitocal 333-G



VITOTRONIC 200

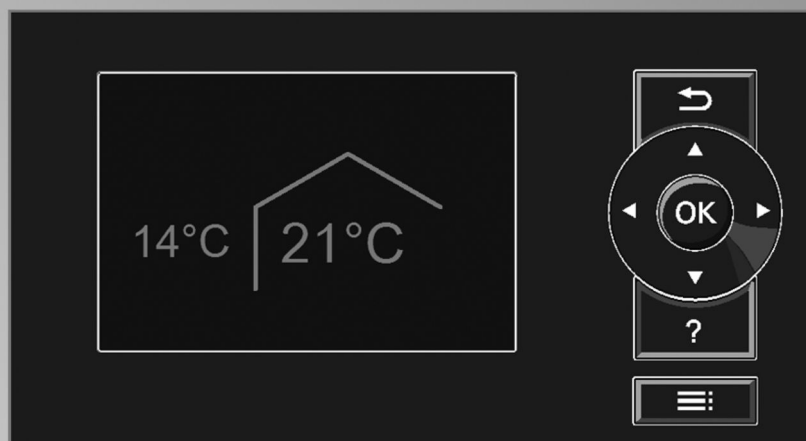

Safety instructions

Safety instructions



Please follow these safety instructions closely to prevent accidents and material losses.

Safety instructions explained



Danger

This symbol warns against the risk of injury.



Please note

This symbol warns against the risk of material losses and environmental pollution.

Note

Details identified by the word "Note" contain additional information.

Target group

These instructions are exclusively intended for qualified contractors.

- Work on the refrigerant circuit may only be carried out by authorised refrigeration engineers.
- Work on electrical equipment may only be carried out by a qualified electrician.
- The system must be commissioned by the system installer or a qualified person authorised by the installer.

Regulations to be observed

- National installation regulations
- Statutory regulations for the prevention of accidents
- Statutory regulations for environmental protection
- Codes of practice of the relevant trade associations
- Relevant country-specific safety regulations

Safety instructions for working on the system

Working on the system

- Isolate the system from the power supply, e.g. by removing the separate fuse or by means of a mains isolator, and check that it is no longer live.

Note

In addition to the control circuit there may be several power circuits.



Danger

Contact with live components can result in severe injuries. Some components on PCBs remain live even after the power supply has been switched off.

Prior to removing covers from the appliances, wait at least 4 minutes until the voltage has completely dropped out.

- Safeguard the system against reconnection.
- Wear suitable personal protective equipment when carrying out any work.



Danger

Hot surfaces and fluids can lead to burns or scalding.

- Before maintenance and service work, switch OFF the appliance and let it cool down.
- Never touch hot surfaces on the appliance, fittings or pipework.



Please note

Electronic assemblies can be damaged by electrostatic discharge.

Prior to commencing work, touch earthed objects such as heating or water pipes to discharge static loads.

Repair work



Please note

Repairing components that fulfil a safety function can compromise the safe operation of the system.

Replace faulty components only with genuine Viessmann spare parts.

Auxiliary components, spare and wearing parts



Please note

Spare and wearing parts that have not been tested together with the system can compromise its function. Installing non-authorised components and making non-approved modifications or conversions can compromise safety and may invalidate our warranty.

For replacements, use only original spare parts supplied or approved by Viessmann.

Safety instructions (cont.)**Safety instructions for operating the system****What to do if water escapes from the appliance****Danger**

If water escapes from the appliance there is a risk of electrocution.

Switch OFF the heating system at the external isolator (e.g. fuse box, domestic distribution board).

**Danger**

If water escapes from the appliance there is a risk of scalding.

Never touch hot heating water.

1. Information	Symbols	15
2. Introduction	Scope of functions	16
	■ System examples	16
	Appliance types	16
	■ Compact brine/water heat pumps □	16
	■ Air/water heat pumps for indoor and outdoor installation, monoblock version ⊗	17
	■ Air/water heat pumps with indoor and outdoor unit, split version ⊗ □	17
	■ Air/water heat pumps with indoor and outdoor unit, monoblock version ⊗ □	20
	■ Refrigerant circuit controller	23
	Setting levels	24
	■ System user	24
	■ Contractor	24
	Programming unit	25
3. Function description	Primary source ice store/Solar air absorber □	26
	■ Summer mode	26
	■ Operation with external heat generator (not for compact appliances)	27
	■ Monitoring the absorber circuit	27
	2-stage refrigerant circuit ⊗ [6]	27
	■ Switching on the compressor	28
	■ Switching off the compressor	28
	Heat pump cascade ⊗ □ / ⊗	29
	■ Integrating a heat pump control unit into LON	30
	■ Calling up heat pumps	31
	■ Shutting down heat pumps	32
	External functions	32
	■ Overview of external functions	32
	External hook-up for heating/cooling circuits	33
	■ Connection	33
	■ Parameter settings	33
	■ Signal effects	34
	■ Set flow temperatures	34
	Power-OFF	34
	Smart Grid	35
	■ Connection to EA1 extension	35
	■ Connection to heat pump control unit	36
	■ Functions	36
	Booster heaters	37
	■ External heat generator	38
	■ Instantaneous heating water heater	39
	DHW heating	40
	■ DHW heating by the heat pump	40
	■ DHW reheating with booster heaters	42
	■ Solar DHW heating	43
	■ Frost protection	43
	Buffer cylinder	43
	■ Overview of buffer cylinders	44
	■ Buffer cylinder in conjunction with heat pump cascade ⊗ □ / ⊗	45
	■ Heating the buffer cylinder with the heat pump	45
	■ Heating the buffer cylinder with booster heaters	46
	■ Stop optimisation	46
	■ Cooling of the heating water/coolant buffer cylinder ⊗ □ / ⊗	46
	■ Frost protection	47
	Low loss header	47
	Heating circuits/cooling circuits	48

■ Notes on minimum flow rate	48
■ System configurations	48
■ Weather-compensated control	50
■ Room temperature-dependent control	51
■ Heating limit and cooling limit	51
■ Changeover between central heating and central cooling	51
■ Starting central heating	52
■ Switching off central heating	52
■ Starting central cooling	52
■ Deactivating central cooling	53
■ Operating status for central heating/cooling	53
■ Central heating with booster heaters	54
■ Central heating with ventilation unit (supply air heating)	54
■ Cooling via a separate cooling circuit	54
Natural cooling function (NC) <input type="checkbox"/>	55
Active cooling function (AC) <input checked="" type="checkbox"/> / <input checked="" type="checkbox"/>	55
■ System without buffer cylinder	55
■ System with heating water buffer cylinder	55
■ System with heating water/coolant buffer cylinder	56
Swimming pool heating	56
■ Switching swimming pool heating on and off	56
■ Connections at EA1 extension	57
Mechanical ventilation	57
Mechanical ventilation with Vitovent 200-C/300-F	58
■ Controlled mechanical ventilation	58
■ Passive heating	59
■ Passive cooling	60
■ Vitovent 200-C: Frost protection	61
■ Vitovent 300-F: Frost protection	63
■ Vitovent 300-F: Supply air heating	63
■ Protection against excessively high temperatures	64
■ Vitovent 300-F: Humidity and/or CO ₂ concentration control	64
Mechanical ventilation with Vitovent 200-W/300-C/300-W	65
■ Controlled mechanical ventilation	65
■ Passive cooling	66
■ Cooling via geothermal heat exchanger	67
■ Frost protection with factory-fitted electric preheating coil	67
■ Frost protection with additional electric preheating coil	67
■ Frost protection with geothermal heat exchanger	67
■ Protection against excessively high temperatures	68
■ Humidity and/or CO ₂ concentration control	68
Photovoltaics	69
■ Enabling utilisation of power generated on site	70
■ Output matching	70
■ DHW heating	70
■ Buffer cylinder heating	71
■ Central heating	71
■ Cooling the heating water/coolant buffer cylinder	72
■ Central cooling	72
4. Troubleshooting	
Overview	73
Calling up messages	74
Message overview	75
■ 02 Data error stand.settg	75
■ 03 Configuration fault	75
■ 04 Elec. heating blocked	77
■ 05 Refrigerant circuit	77
■ 07 Refrigerant circuit	78
■ 09 Electricity meter PV	78

■ 0E Ventilation unit	78
■ 0F Ventilation unit	78
■ 10 Outside temp. sensor	78
■ 18 Outside temp. sensor	79
■ 20 Flow sensor secondary	79
■ 21 Return sensor secndry	79
■ 24 Suction gas revers. temp.	79
■ 25 LPG temp. sensor	79
■ 28 Flow sensor secondary	80
■ 29 Return sensor secndry	80
■ 2C Suction gas revers. temp.	80
■ 2D Liquid gas temp sensor	80
■ 30 Flow sensor primary	81
■ 31 Return sensor primary	81
■ 32 Evaporator temp.sensr	81
■ 36 Hot gas temp sensor 1	81
■ 37 Hot gas temp sensor 2	82
■ 38 Flow sensor primary	82
■ 39 Return sensor primary	82
■ 3A Evaporator temp.sensr	82
■ 40 Flow sensor HC2	83
■ 41 Flow sensor HC3	83
■ 43 Flow sensor system	83
■ 44 Flow sensor cooling	83
■ 48 Flow sensor HC2	83
■ 49 Flow sensor HC3	84
■ 4B Flow sensor system	84
■ 4C Flow sensor cooling	84
■ 50 Cylinder sensor top	84
■ 52 Cylinder sensor bottom	84
■ 58 Cylinder sensor top	85
■ 5A Cylinder sensor bottom	85
■ 60 Buffer temp. sensor	85
■ 63 Boiler sensor ext HS	85
■ 65 Buffer outlet temp.	86
■ 66 Swimming pool flow t.	86
■ 68 Buffer temp. sensor	86
■ 6B Boiler temp.sensor ext	86
■ 6E Flow sens condenser	86
■ 70 Room temp. sensor HC1	87
■ 71 Room temp. sensor HC2	87
■ 72 Room temp. sensor HC3	87
■ 73 Room temp. sensor SKK	87
■ 78 Room temp. sensor HC1	88
■ 79 Room temp. sensor HC2	88
■ 7A Room temp. sensor HC3	88
■ 7B Room temp. sensor SKK	88
■ 90 Solar module sensor 7	88
■ 91 Solar module sensor 10	89
■ 94 Cylinder sensor solar	89
■ 98 Solar module sensor 7	89
■ 99 Solar module sensor 10	89
■ 9A Collector temp. sensor	89
■ 9C Cylinder sensor solar	90
■ 9E Delta T mon. solar	90
■ 9F Internal fault, solar	90
■ A0 Ventilation. Check filter(s)	90
■ A1 compressor 1	90
■ A2 compressor 2	91
■ A6 Secondary pump	91

■ A8 Heating circ. pump HC1	92
■ A9 Heat pump	92
■ AA Cancel defrost	93
■ AB Instant.htg wtr heater	93
■ AC compressor block	93
■ AD Mixer heating/DHW	94
■ AE Cyl sensor top/bottom	94
■ AF Cylinder primary pump	94
■ B0 Device recognition	94
■ B4 AD converter	95
■ B5 Hardware	95
■ BF Communication module	95
■ C2 Power supply	96
■ C3 Pressure switch prim.	96
■ C5 Power-OFF	96
■ C9 Refrigerant circ (SHD)	96
■ CA Protectn device primry	97
■ CB Flow temp. primary	98
■ CC Coding card	98
■ CF Communication module	98
■ D1 Compressor safety	98
■ D3 Low pressure	99
■ D4 Control high pressure	99
■ D5 Contact humidistat	100
■ D6 Flow switch	101
■ D7 Flow switch	101
■ E0 LON subscriber	101
■ E1 External heat source	101
■ E6 Fault at LON subschr.	102
■ EE KM BUS subscriber	102
■ EF Modbus subscriber	102
■ F2 Parameters 5030/5130	102
■ FF New start	102
Nothing displayed on programming unit display	102

5. Diagnosis

Diagnosis (service scans)	103
System overview	110
System	120
■ Timer	120
■ Integrals	121
■ Logbook	123
Ventilation	128
■ Ventilation: Overview	128
■ Ventilation	130
■ Message history Vitovent 200-C/300-F	132
■ Vitovent 200-W/300-C/300-W message history	135
Heat pump	136
■ Compressor runtime	136
Refrigerant circuit	137
■ Refrigerant circ controller ☒ [2] / [6]	137
■ Refrigerant circ ctrllr ☒ [4]	139
■ Refrigerant circ controller ☒ □ [4-3]/[4-4]	141
■ Refrigerant circ controller □ [4-6] / [4-7]	143
■ Refrigerant circ controller ☒ □ [7] / [7-1]	145
■ Compressor travel	146
■ Compressor path	147
■ Message history ☒ [2]	148
■ Message history ☒ [4]	153
■ Message history ☒ □ [4-3] / [4-4]	159

	■ Message history <input type="checkbox"/> [4-6] / [4-7]	164
	■ Message history <input checked="" type="checkbox"/> [6]	172
	■ Message history <input checked="" type="checkbox"/> <input type="checkbox"/> [7] / [7-1]	175
	Energy statement	178
	■ Calling up the energy statement	179
	■ Calling up the seasonal performance factor	179
	Photovoltaics	180
	■ PV statistics	180
	■ DHW loading statistics	181
	■ Output curves	182
	Brief scan	182
	System information	183
6. Actuator test	Actuator test (testing outputs)	185
7. Sensor matching	186
8. Service functions	LON subscriber check	187
	Service PIN	187
	Subscribers (Modbus/KM-BUS)	187
	Enter Vitocom PIN code	188
	Function check	188
	Saving/loading settings	192
	■ Saving settings	192
	■ Load settings	192
9. Control unit settings	Coding level 1 in the service menu	193
	■ Activating the service menu (setting parameters marked <input type="checkbox"/>)	193
	■ Deactivating the service menu	193
	Setting parameters	194
	■ Bit field	194
	Restoring delivered condition (reset)	195
10. Parameter group System definition	Calling up the parameter group	196
	7000 System scheme <input type="checkbox"/>	196
	7002 Interval for long term average outside temperature <input type="checkbox"/>	197
	7003 Temperature differential for calculating the heating limit <input type="checkbox"/>	197
	7004 Temperature differential for calculating the cooling limit <input type="checkbox"/>	198
	7007 Primary pump for natural cooling <input type="checkbox"/> <input type="checkbox"/>	198
	7008 Swimming pool <input type="checkbox"/>	199
	700A Cascade control <input type="checkbox"/> <input checked="" type="checkbox"/> <input type="checkbox"/> / <input checked="" type="checkbox"/>	199
	700C Use of heat pump in cascade <input type="checkbox"/> <input checked="" type="checkbox"/> <input type="checkbox"/> / <input checked="" type="checkbox"/>	199
	700D Runtime balance cascade <input type="checkbox"/> <input checked="" type="checkbox"/> <input type="checkbox"/> / <input checked="" type="checkbox"/>	199
	700F Output control strategy, cascade <input type="checkbox"/> <input checked="" type="checkbox"/> <input type="checkbox"/> / <input checked="" type="checkbox"/>	199
	7010 External extension <input type="checkbox"/>	200
	7011 System components for external changeover <input type="checkbox"/>	200
	7012 Operating status for external changeover <input type="checkbox"/>	201
	7013 Duration of external changeover <input type="checkbox"/>	201
	7014 Effect of external demand on heat pump/heating circuits <input type="checkbox"/>	202
	7015 Effect of ext. blocking on heat pump/heating circuits <input type="checkbox"/>	202
	7017 Vitocom 100 <input type="checkbox"/>	203
	7018 Temperature range input 0..10V <input type="checkbox"/>	203
	7019 Priority external demand <input type="checkbox"/>	203
	701A Effect of external blocking on pumps/compressor <input type="checkbox"/>	203
	701B Common flow temperature sensor system <input type="checkbox"/>	204
	701C Operating status after message A9, C9 <input type="checkbox"/>	204
	701F Effect of OM changeover to ventilation <input type="checkbox"/>	204
	7029 Number of lag heat pumps <input type="checkbox"/> <input checked="" type="checkbox"/> <input type="checkbox"/> / <input checked="" type="checkbox"/>	205
	7030 Select primary source <input type="checkbox"/> <input type="checkbox"/>	205

7031 Start hysteresis solar air absorber	1	1	205
7032 Solar absorber hysteresis	1	1	205
7033 Minimum temp. for solar absorber primary source	1	1	206
7034 Average ground temperature in summer mode	1	1	206
7035 Min. runtime to suppress summer mode	1	1	206
7036 Last calendar week for summer mode	1	1	206
7037 Absorber circuit monitoring	1	1	207
7038 Temperature sensor for dual mode operation	1	1	207
7039 Calendar week, start summer mode, ice store	1	1	207
703A Calendar week, earliest end summer mode, ice store	1	1	207
7044 Type of assembly kit	1	⊗	207
7050 Holiday program effect	1		208
11. Parameter group Compressor			
Calling up the parameter group			209
5000 Enable compressor	1	⊗	209
5010 Evaporator temperature for defrost end	1	⊗	209
5012 Enable use of compressor stage	1		209
5030 Output compressor stage	1		210
5043 Primary source output	1		210
509E Enable compr stage for tandem operation	1	/⊗	210
509F Enable compr 2 for hydraulic circuit	1	/⊗	210
12. Parameter group External heat source			
Calling up the parameter group			211
7B00 Enable external heat source	1		211
7B01 Priority ext. heat source/instant. heating water heater	1		211
7B02 Dual mode temperature external heat source	1		211
7B03 Start threshold external heat source	1		212
7B04 Start delay external heat source	1		212
7B05 Min. flow temperature mixer external heat source ON	1		212
7B06 Min. runtime external heat source	1		212
7B07 Run-on time external heat source	1		213
7B0B Max. excess flow temp external heat source	1		213
7B0C Enable external heat gen. for central heating	1		213
7B0D Enable external heat source for DHW heating	1		213
7B0E Dual mode heat pump operation	1		214
7B0F Shutdown limit, heat pump dual mode	1		214
7B10 Enable min. temp. maintenance for ext. HS	1		214
7B11 Enable boiler water temperature sensor	1		215
13. Parameter group DHW			
Calling up the parameter group			216
6000 Set DHW temperature			216
6005 Min. DHW temperature	1		216
6006 Max. DHW temperature	1		216
6007 Hysteresis DHW temperature heat pump	1		217
6008 Hysteresis DHW temperature booster heater	1		217
6009 Start optimisation for DHW heating			218
600A Stop optimisation for DHW heating			218
600C Set DHW temperature 2			218
600D Temperature rise per hour for DHW heating	1		218
600E Temperature sensor at bottom of DHW cylinder	1		219
6011 Max. runtime DHW heating in heating mode	1		219
6012 Max. interruption of DHW heating for central heating	1		219
6014 Enable booster heaters for DHW heating	1		219
6015 Enable electric heaters for DHW heating			220
6016 Priority DHW heating with combi cylinder	1		220
6017 Start attempts for DHW after high pressure shutdown	1		220
601E Shutdown hysteresis inst. heating water heater	1		220
601F Cylinder primary pump enable	1		221
6020 Operating mode cylinder primary pump	1		221

	6040 Enable elec. heating/ext. HS for reheating only <input type="checkbox"/>	221
	6060 Blocking time DHW heating <input type="checkbox"/>	221
	6061 Max. interruption DHW heating <input type="checkbox"/>	222
14. Parameter group Solar	Calling up the parameter group	223
	7A00 Type solar control unit <input type="checkbox"/>	223
	C0xx Parameter solar control module, type SM1 <input type="checkbox"/>	223
15. Parameter group Electric booster heater	Calling up the parameter group	224
	7900 Enable instantaneous heating water heater <input type="checkbox"/>	224
	7901 Enable electric heaters for DHW heating <input type="checkbox"/>	224
	7902 Enable instant. heating water heater for central heating	225
	7905 Start delay instantaneous heating water heater <input type="checkbox"/>	225
	7907 Max. output instantaneous heating water heater <input type="checkbox"/>	225
	790A Output for instant. heating water heater at power-OFF <input type="checkbox"/>	226
	790B Dual mode temp instant. heating water heater <input type="checkbox"/>	226
16. Parameter group Internal hydraulics	Calling up the parameter group	227
	7300 Heat pump for drying a building <input type="checkbox"/>	227
	7303 Time program for screed drying <input type="checkbox"/>	227
	730C Flow temperature for external demand <input type="checkbox"/>	228
	730D Enable 3-way diverter valve heating/DHW <input type="checkbox"/>	229
	730E Start threshold <input type="checkbox"/>	229
	730F Compressor performance at min. outside temperature <input type="checkbox"/>	229
	7310 Compressor performance at max. outside temperature <input type="checkbox"/>	230
	7319 Cycle rate heating circuit pumps <input type="checkbox"/>	230
	7340 Operating mode secondary pump <input type="checkbox"/>	230
	7343 Rated output secondary pump (PWM) <input type="checkbox"/>	231
	734A Rated output heating circuit pump HC2 <input checked="" type="checkbox"/>	231
	735A Secondary circuit pump type <input type="checkbox"/>	231
	7365 Starting time high efficiency circulation pump <input type="checkbox"/>	232
	7378 Screed program start day <input type="checkbox"/>	232
	7379 Screed program end day <input type="checkbox"/>	233
17. Parameter group Primary source	Calling up the parameter group	234
	7400 Primary source mode <input type="checkbox"/>	234
	7401 Primary source ctrl strategy <input type="checkbox"/>	234
	745A Primary circuit pump type <input type="checkbox"/>	234
	7470 Min. primary circuit inlet temperature in operation <input type="checkbox"/>	235
	7471 Response delay, probe protection <input type="checkbox"/>	235
18. Parameter group Buffer cylinder	Calling up the parameter group	236
	7200 Enable buffer cylinder/low loss header <input type="checkbox"/>	236
	7202 Temp in operating status fixed value for buffer cyl <input type="checkbox"/>	236
	7203 Hysteresis temperature heating buffer cylinder <input type="checkbox"/>	236
	7204 Max. temperature buffer cylinder <input type="checkbox"/>	237
	7205 Stop optimisation heating buffer cylinder <input type="checkbox"/>	237
	7208 Temp limit op. status fixed value for buffer cylinder <input type="checkbox"/>	237
	7209 Stop hysteresis, heating water buffer cylinder <input type="checkbox"/>	238
	720A Operating mode, fixed value only for heat demand <input type="checkbox"/>	238
	721F Buffer cyl operating mode <input checked="" type="checkbox"/>	238
	7220 Temp in op. status. Fixed value for coolant buff cyl. <input type="checkbox"/>	238
	7223 Stop hysteresis coolant buffer cylinder <input type="checkbox"/>	238
	722A Min. temperature coolant buffer cylinder <input type="checkbox"/>	239
	722B Start hysteresis coolant buffer cylinder <input type="checkbox"/>	239
19. Parameter group Heating circuits/Cooling circuits	Calling up the parameter group	241
	2000 Standard room temperature	241
	2001 Reduced room temperature	241

Index

2003 Remote control [1]	241
2005 Room temperature control [1]	242
2006 Heating curve level	242
2007 Heating curve slope	242
200A Influence room temperature hook-up [1]	243
200B Room temperature hook-up [1]	243
200E Max. flow temperature heating circuit [1]	243
2015 Runtime mixer heating circ [1]	243
2022 Room temperature in party mode	244
2030 Cooling [1] ⊗ [1] / ⊗	244
2031 Dew point monitor [1] ⊗ [1] / ⊗	244
2033 Min. flow temperature cooling [1] ⊗ [1] / ⊗	244
2034 Influence room temperature hook-up cooling circuit [1] ⊗ [1] / ⊗	245
2040 Cooling curve level ⊗ [1] / ⊗	245
2041 Cooling curve slope ⊗ [1] / ⊗	245

20. Parameter group Cooling

Calling up the parameter group	246
7100 Cooling function [1]	246
7101 Cooling circuit [1]	246
7102 Set room temperature separate cooling circuit	246
7103 Min. flow temperature cooling [1]	246
7104 Influence room temperature hook-up cooling circuit [1]	247
7105 Room temperature control cooling circuit [1]	247
7106 Ranking room temp sensor separate cooling circuit [1]	247
7107 Hysteresis room temp cooling circuit [1]	247
7109 Enable flow temperature sensor cooling circuit [1] ⊗ [1] / ⊗	248
7110 Cooling curve level	248
7111 Cooling curve slope	248
7116 Remote control cooling circ [1]	248
7117 Dew point monitor [1]	249
71FE Enable active cooling	249

21. Parameter group Ventilation

Calling up the parameter group	250
7D00 Vitovent enable [1]	250
7D01 Enable preheater bank electric [1]	250
7D02 Enable reheater bank hydraulic [1]	250
7D04 Enable target temperature control [1]	251
7D05 Enable humidity sensor [1]	251
7D06 Enable CO2 sensor [1]	251
7D08 Set room temperature	251
7D0A Flow rate reduced ventilation [1]	252
7D0B Flow rate nominal ventilation [1]	252
7D0C Flow rate intensive ventilation [1]	252
7D0F Min. supply air temperature for bypass	252
7D18 CO2 value for raising the flow rate [1]	253
7D19 Humidity value for raising the flow rate [1]	253
7D1A Fan blocking time with frost protection [1]	253
7D1B Intensive ventilation duration [1]	254
7D1D Actual source room temperature [1]	254
7D21 Heating circuit for blocking bypass damper [1]	254
7D27 Control voltage matching [1]	255
7D28 Fan for control voltage matching [1]	255
7D2C Strategy, passive frost protection [1]	255
7D2E Type of heat exchanger [1]	255
7D2F Installation position [1]	256
7D3A Function, external 230 V input, ventilation [1]	256
7D3B Duration, bathroom vent. [1]	256
7D5E Starting block, ventilation periods part 1 [1]	256
7D5F Starting block, ventilation periods part 2 [1]	257

	7D71 Control voltage matching, supply air fan <input type="checkbox"/>	257
	7D72 Control voltage matching, exhaust air fan <input type="checkbox"/>	258
	7D75 Sensor matching, outdoor air temperature <input type="checkbox"/>	258
	7D76 Sensor matching, outdoor air temp after preheating coil <input type="checkbox"/>	258
	7D77 Sensor matching, supply air temperature <input type="checkbox"/>	258
	7D79 Sensor matching, extract air temperature <input type="checkbox"/>	258
	C101 Preheater coil <input type="checkbox"/>	259
	C102 Reheater coil <input type="checkbox"/>	259
	C105 Humidity sensor <input type="checkbox"/>	259
	C106 CO2 sensor <input type="checkbox"/>	260
	C108 set room temperature	260
	C109 Background ventilation <input type="checkbox"/>	260
	C10A Reduced ventilation <input type="checkbox"/>	260
	C10B Standard ventilation <input type="checkbox"/>	261
	C10C Intensive ventilation <input type="checkbox"/>	261
	C189 Background ventilation, second fan duct <input type="checkbox"/>	261
	C18A Reduced ventilation, second fan duct <input type="checkbox"/>	262
	C18B Standard ventilation, second fan duct <input type="checkbox"/>	262
	C18C Intensive ventilation, second fan duct <input type="checkbox"/>	262
	C1A0 Bypass mode <input type="checkbox"/>	263
	C1A1 Central heating and heat recovery <input type="checkbox"/>	263
	C1A2 Imbalance permitted <input type="checkbox"/>	263
	C1A3 Specified imbalance <input type="checkbox"/>	264
	C1A4 Set reheater coil temperature <input type="checkbox"/>	264
	C1A6 Humidity sensor sensitivity <input type="checkbox"/>	264
	C1AA Min. temperature, geothermal heat exchanger <input type="checkbox"/>	265
	C1AB Max. temperature, geothermal heat exchanger <input type="checkbox"/>	265
	C1B0 Function, input 1 <input type="checkbox"/>	265
	C1B1 Min. voltage, input 1 <input type="checkbox"/>	265
	C1C1 Min. voltage, input 2 <input type="checkbox"/>	266
	C1C7 Flow rate correction <input type="checkbox"/>	266
22. Parameter group Photovoltaics	Calling up the parameter group	267
	7E00 Enable own energy consumption PV <input type="checkbox"/>	267
	7E02 Prop. of external current <input type="checkbox"/>	267
	7E04 Threshold for electrical power <input type="checkbox"/>	268
	7E10 Enable own energy consumptn for set DHW temperature 2	268
	7E11 Enable own energy consumption for DHW heating	268
	7E12 Enable own energy consumptn for heating water buffer cyl.	269
	7E13 Enable own energy consumption for heating	269
	7E15 Enable own energy consumption for cooling	269
	7E16 Enable own energy consumptn for coolant buffer cylinder	269
	7E21 Raise set DHW cylinder temperature PV	270
	7E22 Raise set heating water buffer cylinder temp PV	270
	7E23 Raise set room temperature PV	270
	7E25 Reduce set room temperature PV	270
	7E26 Reduce set coolant buffer cylinder temperature PV	270
23. Parameter group Smart Grid	Calling up the parameter group	271
	7E80 Enable Smart Grid <input type="checkbox"/>	271
	7E82 Smart Grid Enable elec heat <input type="checkbox"/>	271
	7E91 Smart Grid set value increase for DHW heating	272
	7E92 Smart Grid set value increase for htg wtr buff	272
	7E93 Smart Grid set value increase for centr htg	272
	7E95 Smart Grid set value decrease for room t cool	272
24. Parameter group Time	Calling up the parameter group	273
	7C00 to 7C06 Automatic changeover summertime - wintertime <input type="checkbox"/>	273

Index









25. Parameter group Communication	Calling up the parameter group	274
	7707 Number of heat pump in cascade <input type="checkbox"/> 1	274
	7710 Enable LON communication module <input type="checkbox"/> 1	274
	7777 LON subscriber number <input type="checkbox"/> 1	274
	7779 LON fault manager <input type="checkbox"/> 1	274
	7798 LON system number <input type="checkbox"/> 1	274
	779C Interval for data transfer via LON <input type="checkbox"/> 1	275
	77FC Source outside temperature <input type="checkbox"/> 1	275
	77FD Send outside temperature <input type="checkbox"/> 1	275
	77FE Source time <input type="checkbox"/> 1	275
	77FF Send time <input type="checkbox"/> 1	276
26. Parameter group Control	Calling up the parameter group	277
	8800 Lock out controls <input type="checkbox"/> 1	277
	8801 Level enable, time program quieter operation <input type="checkbox"/> 1	277
	8811 User level for display, energy stnt/SPF <input type="checkbox"/> 1	277
27. PCBs and connection options	Overview of the PCBs	278
	■ Brine/water and air/water heat pumps <input type="checkbox"/> / <input checked="" type="checkbox"/>	278
	■ Heat pumps with separate indoor and outdoor unit <input checked="" type="checkbox"/> <input type="checkbox"/>	279
	Information regarding the electrical connections	279
	Main and expansion PCB	280
	■ Main PCB	280
	■ Expansion PCB on main PCB	284
	■ Connections for DHW heating	287
	Vitocal 300-A cross connect PCB	289
	Luster terminals, Vitocal 100-S/200-A/200-S	292
	Luster terminals, Vitocal 111-S/222-A/222-S	294
	Luster terminals Vitocal 200-A	296
	Vitocal 222-G/333-G luster terminals	299
	Vitocal 100-S/200-A/200-S/300-A controller and sensor PCB	300
	Vitocal 111-S/222-A/222-S/222-G/333-G controller and sensor PCB	302
	EEV PCB <input checked="" type="checkbox"/> [2]	304
	■ Inverter	305
	EEV PCB <input checked="" type="checkbox"/> [4]	306
	EEV PCB <input checked="" type="checkbox"/> <input type="checkbox"/> [4-3] / [4-4]	307
	EEV PCB <input type="checkbox"/> [4-6] / [4-7]	308
	■ [4-6]: Vitocal 333-G	308
	■ [4-7]: Vitocal 222-G	309
	Controller PCB and EEV PCB <input checked="" type="checkbox"/> [6]	310
	■ Controller PCB: Type AWO 301.A25 to A60	310
	■ EEV PCB: Type AWO 301.A60	311
	Main PCB <input checked="" type="checkbox"/> <input type="checkbox"/> [7] / [7-1]	312
	■ Jumper ID (blue)	313
28. Sensors	Temperature sensors	314
	■ Viessmann NTC 10 kΩ (blue marking)	314
	■ Viessmann NTC 20 kΩ (orange marking)	315
	■ Viessmann Pt500A (green marking)	316
	■ Connection to EEV PCB [4-3] / [4-4] / [4-6] / [4-7]: NTC 10 kΩ (no marking)	317
	■ Connection to EEV PCB [6]: NTC 10 kΩ (no marking)	318
	■ Connection to main PCB [7] / [7-1]: NTC 15 kΩ (no marking)	319
	■ Connection to main PCB [7] / [7-1]: NTC 20 kΩ (no marking)	320
	■ Connection to main PCB [7] / [7-1]: NTC 50 kΩ (no marking)	321
	Pressure sensors	321
	■ Connection to EEV PCB [4] / [4-3] / [4-4] / [4-6] / [4-7]	321
	■ Connection to EEV PCB [2] / [6] / [7] / [7-1]	322

Index



Index (cont.)

29. Certificates	Declarations of conformity for heat pumps	323
30. Keyword index	324

Symbols

Symbol	Meaning
	Reference to other document containing further information
	Step in a diagram: The numbers correspond to the order in which the steps are carried out.
	Warning of material losses and environmental pollution
	Live electrical area
	Pay particular attention.
	<ul style="list-style-type: none"> ▪ Component must audibly click into place. or ▪ Acoustic signal
	<ul style="list-style-type: none"> ▪ Fit new component. or ▪ In conjunction with a tool: Clean the surface.
	Dispose of component correctly.
	Dispose of component at a suitable collection point. Do not dispose of component in domestic waste.

Appliance types

Symbol	Meaning
	Content only applies to brine/water heat pumps.
	Content only applies to air/water heat pumps for indoor or outdoor installation, monoblock version.
	Content only applies to air/water heat pumps with separate indoor and outdoor unit, split or monoblock version.

Refrigerant circuit controller

Symbol	Meaning
[2]	Content only applies to heat pumps with refrigerant circuit controller 2, e.g. Vitocal 200-A.
[4]	Content only applies to heat pumps with refrigerant circuit controller 4, e.g. Vitocal 300-A, type AWO-AC 301.B.
[4-3]	Content only applies to heat pumps with refrigerant circuit controller 4-3, e.g. Vitocal 200-A.
[4-4]	Content only applies to heat pumps with refrigerant circuit controller 4-4, e.g. Vitocal 200-S.
[4-6]	Content only applies to heat pumps with refrigerant circuit controller 4-6, e.g. Vitocal 333-G.
[4-7]	Content only applies to heat pumps with refrigerant circuit controller 4-7, e.g. Vitocal 222-G.
[6]	Content only applies to heat pumps with refrigerant circuit controller 6, e.g. Vitocal 300-A, type AWO 302.B25 to B60.
[7]	Content only applies to heat pumps with refrigerant circuit controller 7, e.g. Vitocal 100-S.
[7-1]	Content only applies to heat pumps with refrigerant circuit controller 7-1, e.g. Vitocal 100-S.

Scope of functions

These service instructions include the following information regarding the **Vitotronic 200, type WO1C** heat pump control unit for air/water heat pumps with separate indoor and outdoor unit:

- Function description
- Control parameters for matching the heat pump to different requirements and operating conditions
- Diagnosis options for heating system and refrigerant circuit
- Troubleshooting measures
- Overview of electrical connections

The functions and control characteristics of the heat pump control unit are matched to the relevant heat pump by means of the coding card. As a consequence, the full scope of functions described here is not necessarily available for every heat pump type. In addition, the selected system scheme and the auxiliary equipment also influence the functions available in the heat pump control unit.

Type or system-specific details are only highlighted in those places where they have a direct effect on the characteristics of the heat pump or the heating system.

System examples

System examples with hydraulic and electric connection diagrams as well a detailed function description are available to aid the understanding of the heat pump control unit function.

Detailed information regarding system examples: www.viessmann-schemes.com

Appliance types

Compact brine/water heat pumps

All of the heat pump components, including the heat pump control unit and a DHW cylinder, are housed in one appliance.

The Vitocal 333-G has a variable speed compressor. The Vitocal 222-G has a fixed speed compressor.

Overview of system components and functions for compact brine/water heat pumps

System component/function	Page	Vitocal 222-G	Vitocal 333-G
Primary source, ice store/solar air absorber	26	X	X
Heating/cooling circuits	48	In conjunction with buffer cylinder: <ul style="list-style-type: none"> ▪ A1/HC1 ▪ M2/HC2: Mixer motor directly controlled ▪ M3/HC3: Mixer motor controlled via KM-BUS 	
Instantaneous heating water heater	39	Factory-fitted	Factory-fitted
Heating water buffer cylinder	43	X	X
Heating water/coolant buffer cylinder	43	—	—
Central heating	48	X	X
Central cooling	55	Natural cooling function in conjunction with NC-Box (accessories)	
DHW heating	40	DHW cylinder integrated	
Swimming pool heating	56	X	X
Mechanical ventilation	57	X	X
Photovoltaics	69	X	X
Smart Grid	35	X	X

Note

The following functions are not possible with brine/water heat pumps:

- Dual mode operation with an external heat generator
- Heat pump cascade

Appliance types (cont.)

Air/water heat pumps for indoor and outdoor installation, monoblock version 

All components of the refrigerant circuit are installed in a single appliance.

Heat pumps for indoor installation

The heat pump is supplied with outdoor air via an air duct. Expelled air leaves the building via another air duct.

The refrigerant circuit has a variable speed compressor. The secondary pump, the 3-way diverter valve "central heating/DHW heating" and the heat pump control unit are built into the heat pump.

Heat pumps for outdoor installation

The heat pump is installed outdoors. The building is heated or cooled via the hydraulic connection lines. These hydraulic connection lines, together with the electrical connecting cables, are laid in the ground with frost protection.

The heat pump control unit is located in a separate enclosure inside the building. The hydraulic components for distribution in the secondary circuit, such as the secondary pump, are also installed in the building.

Overview of system components and functions for air/water heat pumps for indoor or outdoor installation, monoblock version

System component/function	Page	Heat pump for indoor installation Vitocal 200-A	Heat pump for outdoor installation Vitocal 300-A
Heating/cooling circuits	48	In conjunction with buffer cylinder: <ul style="list-style-type: none"> ▪ A1/HC1 ▪ M2/HC2: Mixer motor directly controlled ▪ M3/HC3: Mixer motor controlled via KM-BUS 	In conjunction with buffer cylinder: <ul style="list-style-type: none"> ▪ A1/HC1 ▪ M2/HC2: Mixer motor directly controlled ▪ M3/HC3: Mixer motor controlled via KM-BUS
Instantaneous heating water heater	39	Factory-fitted	Depending on type, supplied on site or accessories
External heat generator	38	X	X
Heating water buffer cylinder	43	X	X
Heating water/coolant buffer cylinder	43	X	X
Central heating	48	X	X
Room cooling	55	X	Depending on type
DHW heating	40	Separate DHW cylinder	Separate DHW cylinder
Heat pump cascade	29	X	Depending on type
Swimming pool heating	56	X	X
Mechanical ventilation	57	X	X
Photovoltaics	69	X	X
Smart Grid	35	X	X

Air/water heat pumps with indoor and outdoor unit, split version  

The heat pumps comprise an outdoor unit for installation outside the building and an indoor unit for installation inside the building.

Except for the condenser, all components of the refrigerant circuit are located in the outdoor unit, including the refrigerant circuit controller.

Appliance types (cont.)

Alongside the hydraulic components for the secondary circuit, the indoor unit also houses the refrigerant circuit condenser and Vitotronic 200, type WO1C heat pump control unit.

The indoor and outdoor units are hydraulically connected to each other via refrigerant lines. The indoor and outdoor units communicate via Modbus.

Indoor unit as wall mounted appliance

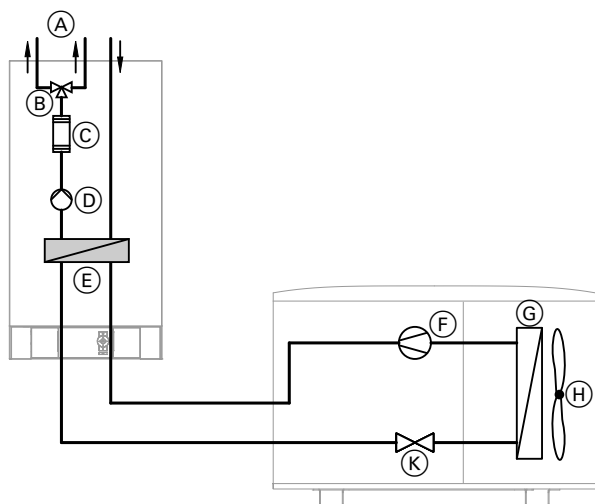

Fig. 1

- Ⓐ Secondary circuit flow (central heating and DHW heating)
- Ⓑ 3-way diverter valve "Central heating/DHW heating"
- Ⓒ Instantaneous heating water heater (factory-fitted or as accessory, depending on type)
- Ⓓ Secondary pump
- Ⓔ Condenser
- Ⓕ Compressor
- Ⓖ Evaporator
- Ⓗ Fan
- Ⓚ Electronic expansion valve

Compact indoor unit without installation kit with mixer

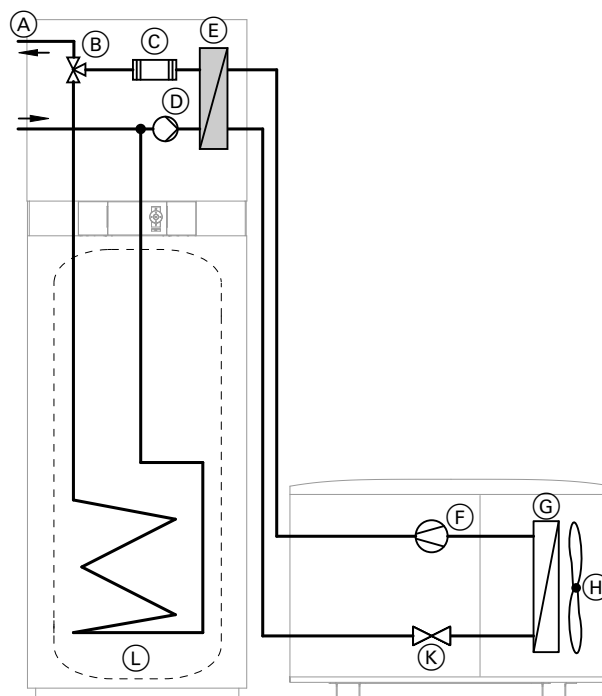

Fig. 2

- Ⓐ Secondary circuit flow (central heating only)
- Ⓑ 3-way diverter valve "Central heating/DHW heating"
- Ⓒ Instantaneous heating water heater (factory-fitted or as accessory, depending on type)
- Ⓓ Secondary pump
- Ⓔ Condenser
- Ⓕ Compressor
- Ⓖ Evaporator
- Ⓗ Fan
- Ⓚ Electronic expansion valve
- Ⓛ DHW cylinder

Appliance types (cont.)

Compact indoor unit with installation kit with mixer (accessories)

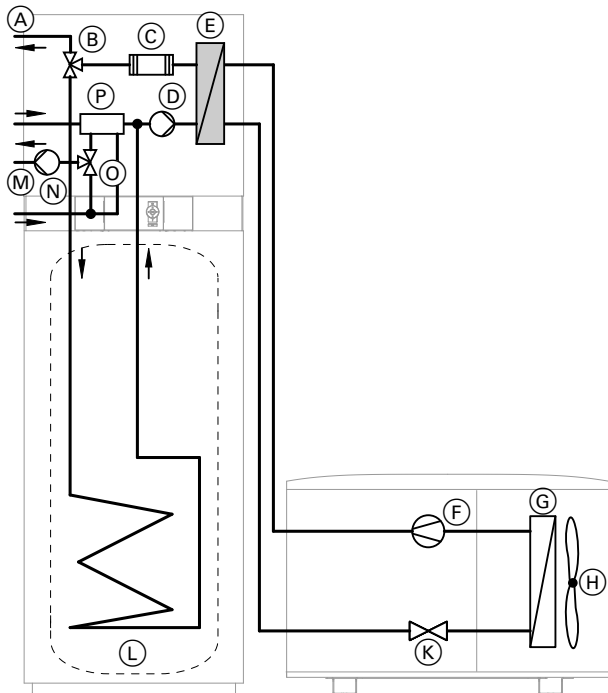

Fig. 3

- (A) Flow, heating circuit without mixer A1/HC1
- (B) 3-way diverter valve "Central heating/DHW heating"
- (C) Instantaneous heating water heater (factory-fitted or as accessory, depending on type)
- (D) Secondary pump
- (E) Condenser
- (F) Compressor
- (G) Evaporator
- (H) Fan
- (K) Electronic expansion valve
- (L) DHW cylinder
- (M) Flow, heating circuit with mixer M2/HC2
- (N) Heating circuit pump
- (O) 3-way mixer
- (P) Low loss header

Appliance types (cont.)

Overview of system components and functions for air/water heat pumps with indoor and outdoor units, split version

System component/function	Page	Indoor unit as wall mounted unit		Indoor unit as compact unit	
		Vitocal 100-S	Vitocal 200-S	Vitocal 111-S	Vitocal 222-S
Heating/cooling circuits	48	In conjunction with buffer cylinder: <ul style="list-style-type: none"> ▪ A1/HC1 ▪ M2/HC2: Mixer motor directly controlled ▪ M3/HC3: Mixer motor controlled via KM-BUS 		In conjunction with buffer cylinder: <ul style="list-style-type: none"> ▪ A1/HC1 ▪ M2/HC2: Mixer motor directly controlled ▪ M3/HC3: Mixer motor controlled via KM-BUS In conjunction with installation kit with mixer, without buffer cylinder: <ul style="list-style-type: none"> ▪ A1/HC1 ▪ M2/HC2: Mixer motor directly controlled 	
Instantaneous heating water heater	39	Depending on type, factory-fitted	Depending on type, factory-fitted or accessory	Accessories	Depending on type, factory-fitted or accessory
External heat generator	38	X	X	—	—
Heating water buffer cylinder	43	X	X	X Only without installation kit with mixer	X Only without installation kit with mixer
Heating water/coolant buffer cylinder	43	X	X	X Only without installation kit with mixer	X Only without installation kit with mixer
Central heating	48	X	X	X	X
Central cooling	55	Depending on type		Depending on type	
DHW heating	40	Separate DHW cylinder		DHW cylinder integrated	
Heat pump cascade	29	X	X	—	—
Swimming pool heating	56	X	X	X	X
Mechanical ventilation	57	X	X	X	X
Photovoltaics	69	X	X	X	X
Smart Grid	35	X	X	X	X

Air/water heat pumps with indoor and outdoor unit, monoblock version  

The heat pumps comprise an outdoor unit for installation outside the building and an indoor unit for installation inside the building.

All components of the refrigerant circuit are located in the outdoor unit, including the refrigerant circuit controller.

Alongside the hydraulic components for the secondary circuit, the indoor unit houses the Vitotronic 200, type WO1C heat pump control unit.

The indoor and outdoor units are hydraulically connected to each other via the flow and return of the secondary circuit. The indoor and outdoor units communicate via Modbus.

Appliance types (cont.)

Indoor unit as wall mounted appliance

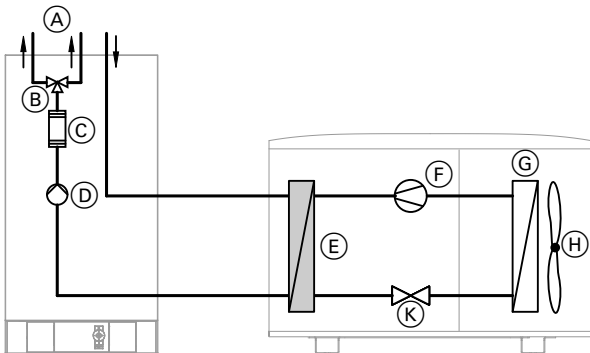

Fig. 4

- (A) Secondary circuit flow (central heating and DHW heating)
- (B) 3-way diverter valve "Central heating/DHW heating"
- (C) Instantaneous heating water heater (factory-fitted or as accessory, depending on type)
- (D) Secondary pump
- (E) Condenser
- (F) Compressor
- (G) Evaporator
- (H) Fan
- (K) Electronic expansion valve

Compact indoor unit without installation kit with mixer

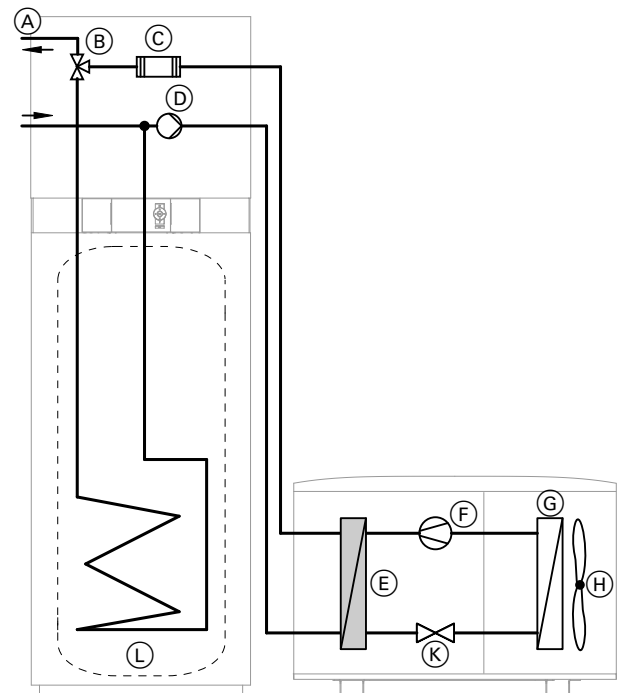

Fig. 5

- (A) Secondary circuit flow (central heating only)
- (B) 3-way diverter valve "Central heating/DHW heating"
- (C) Instantaneous heating water heater (factory-fitted or as accessory, depending on type)
- (D) Secondary pump
- (E) Condenser
- (F) Compressor
- (G) Evaporator
- (H) Fan
- (K) Electronic expansion valve
- (L) DHW cylinder

Compact indoor unit with installation kit with mixer (accessories)

Fig. 6

- Ⓐ Flow, heating circuit without mixer A1/HC1
- Ⓑ 3-way diverter valve "Central heating/DHW heating"
- Ⓒ Instantaneous heating water heater (factory-fitted or as accessory, depending on type)
- Ⓓ Secondary pump
- Ⓔ Condenser
- Ⓕ Compressor
- Ⓖ Evaporator
- Ⓗ Fan
- Ⓚ Electronic expansion valve
- Ⓛ DHW cylinder
- Ⓜ Flow, heating circuit with mixer M2/HC2
- Ⓝ Heating circuit pump
- Ⓞ 3-way mixer
- Ⓟ Low loss header

Appliance types (cont.)

Overview of system components and functions for air/water heat pumps with indoor and outdoor units, monoblock version

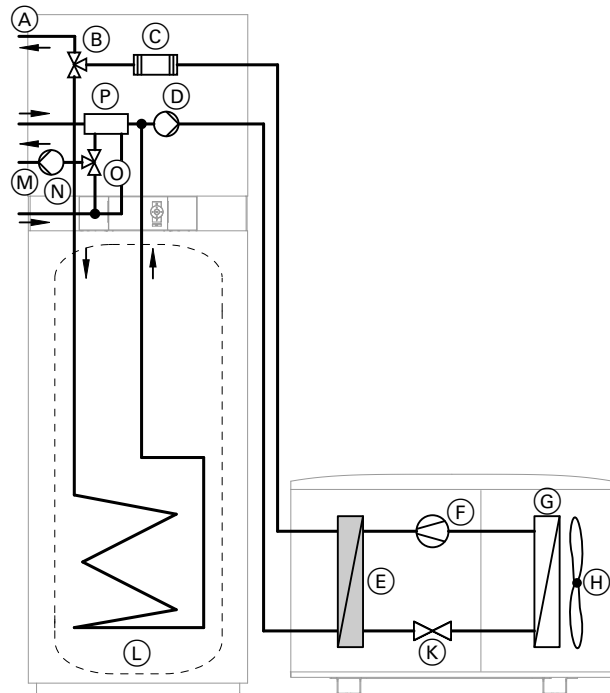
System component/function	Page	Indoor unit as wall mounted appliance Vitocal 200-A	Indoor unit as compact appliance Vitocal 222-A
Heating/cooling circuits	48	In conjunction with buffer cylinder: <ul style="list-style-type: none"> ▪ A1/HC1 ▪ M2/HC2: Mixer motor directly controlled ▪ M3/HC3: Mixer motor controlled via KM-BUS 	In conjunction with buffer cylinder: <ul style="list-style-type: none"> ▪ A1/HC1 ▪ M2/HC2: Mixer motor directly controlled ▪ M3/HC3: Mixer motor controlled via KM-BUS In conjunction with installation kit with mixer, without buffer cylinder: <ul style="list-style-type: none"> ▪ A1/HC1 ▪ M2/HC2: Mixer motor directly controlled
Instantaneous heating water heater	39	Depending on type, factory-fitted	Factory-fitted
External heat generator	38	X	—
Heating water buffer cylinder	43	X	X Only without installation kit with mixer
Heating water/coolant buffer cylinder	43	X	X Only without installation kit with mixer
Central heating	48	X	X
Central cooling	55	Depending on type	Depending on type
DHW heating	40	Separate DHW cylinder	DHW cylinder integrated
Heat pump cascade	29	X	—
Swimming pool heating	56	X	X
Mechanical ventilation	57	X	X
Photovoltaics	69	X	X
Smart Grid	35	X	X

Refrigerant circuit controller

Depending on the heat pump type, different refrigerant circuit controllers are installed: Refrigerant circuit controller [2] to [7-1].

Content in these service instructions relating only to a certain type of refrigerant circuit controller is identified with the relevant symbol, e.g. [7].

**Please note**

Service steps that are unsuitable for the fitted refrigerant circuit controller can result in material losses.

Prior to commencing work, call up the integral refrigerant circuit controller at the heat pump control unit.

1. Service menu:

Press **OK** + **≡**: simultaneously and hold for approx. 4 s.

2. "Diagnosis"**3. "System information"**

For an explanation of the indicated system information, see chapter "System information".

Appliance types (cont.)**Refrigerant circuit controller**

Heat pump	Refrigerant circuit controller							
	[2]	[4]	[4-3]	[4-4]	[4-6]	[4-7]	[6]	[7] / [7-1]
Brine/water heat pumps □								
▪ Vitocal 222-G						X		
▪ Vitocal 333-G					X			
Air/water heat pumps for indoor installation, monoblock version ⊗								
▪ Vitocal 200-A, type AWCI-AC 201.A	X							
Air/water heat pumps for outdoor installation, monoblock version ⊗								
▪ Vitocal 300-A, type AWO-AC 301.B		X						
▪ Vitocal 300-A, type AWO 302.B							X	
Air/water heat pumps with indoor/outdoor units, split version ⊗ □								
▪ Vitocal 100-S								X
▪ Vitocal 111-S								X
▪ Vitocal 200-S				X				
▪ Vitocal 222-S				X				
Air/water heat pumps with indoor/outdoor units, monoblock version ⊗ □								
▪ Vitocal 200-A, type AWO(-M)/AWO(-M)-E/ AWO(-M)-E-AC 201.A			X					
▪ Vitocal 222-A			X					

Setting levels

To avoid incorrect operation of the heat pump and other system components, not all menus are available at every setting level. For example, control parameters can only be called up at the contractor setting level.

System user

Operation takes place in the standard menu and in the extended menu and is suitable for individuals who have been trained in the operation of the heating system by a heating contractor.

- The general operating functions and displays are found in the standard menu. For example, setting of the room temperature set value or selection of the operating program.
- The extended menu offers further functions, such as the setting of time programs, for example. To call up the extended menu, press .



For functions at the "System user" setting level, see the operating instructions.

Contractor

Additional functions and the parameters of Coding level 1 are available at this setting level. These functions and parameters are identified by the  symbol.

Setting levels (cont.)

- The "Contractor" setting level includes the functions of the "System user" setting level.
- The settings of Coding level 1 may only be carried out by heating contractor personnel who have been trained in the use of Viessmann heat pumps.

To call up coding level 1, see page 193.

Programming unit

Standard menu

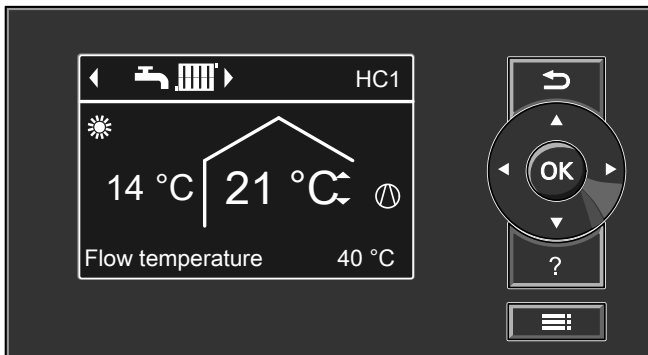

Fig. 7

- ↶ One step back in the menu or cancellation of the setting that has been started
- ⤴ Cursor keys for scrolling through the menu or for setting values
- OK** Confirm selection or save the setting made.
- ?** Call up "**Operating info**" or additional information on the selected menu.
- ☰ Call up extended menu.

Primary source ice store/Solar air absorber 

As an alternative to geothermal probes/collectors, an ice store and a solar air absorber can be used as the primary source for the heat pump. For this, **"Select primary source 7030"** must be set to **"1"**.
 The medium in the ice store is heated by the surrounding ground and by the solar air absorber. The heat pump draws this primary energy from the ice store. If in the course of this the medium falls below freezing point, the heat pump also utilises the crystallisation energy. The ice store freezes from the inside out and thaws again from the outside in.
 As an alternative to the ice store, the solar air absorber can also be used as immediate primary source. A 3-way diverter valve changes over between the two primary sources.

In cooling mode (natural cooling), the thermal energy drawn from the rooms is fed to the ice store.

The ice store is heated via the solar air absorber if **all** of the following conditions are being met (parameters set on Vitosolic):

- Temperature differential solar air absorber – Ice store > **"ΔTon"**.
- Absorber temperature > **"Th6on"**.
- Temperature in the ice store < **"Tcylset"**.

Activation conditions for primary source

Primary source	Central heating	Central cooling	Temperature differential solar air absorber – Ice store	Absorber temperature
Ice store	ON	ON	< 0	–
Solar air absorber	ON	OFF	> "Start hysteresis solar air absorber 7031"	<ul style="list-style-type: none"> ▪ Absorber temperature > "Minimum temp. for solar absorber primary source 7033" and ▪ Primary inlet temperature is within the valid range.

Electrical devices also required in addition to the heat pump with Vitotronic 200, type WO1C:

Vitosolic 200:

- Temperature differential control for heating the ice store via the solar air absorber
- Setting the set differential temperature
- Enable: **"Type solar control unit 7A00"** set to **"2"**

AM1 extension:

- Changeover between solar air absorber and ice store as primary source via a 3-way diverter valve
- Enable: **"External extension 7010"** set to **"2"** or **"3"**

Ice store extension:

- Switching the 3-way diverter valve and absorber circuit pump

Electrical connection of required equipment and parameter settings:

www.viessmann-schemes.com

Summer mode

Particularly in summer, high temperatures in the ice store lead to heat losses to the ground. Use of the solar air absorber requires frequent reheating. This results in higher energy costs for the absorber circuit pump. To avoid this, the maximum temperature of the ice store is reduced in summer mode to **"Average ground temperature in summer mode 7034"**.

Summer mode is switched on under the following conditions:

- On a single day, the heat pump was operating to provide central heating for **less** than the **"Min. runtime to suppress summer mode 7035"** in operation.
- **"Calendar week, start summer mode, ice store 7039"** is reached.
- The **"Last calendar week for summer mode 7036"** has not yet been reached.

Primary source ice store/Solar air absorber  (cont.)

Summer mode ends under the following conditions:

- If, on a single day after **"Calendar week, earliest end summer mode, ice store 703A"**, the heat pump was operating to provide central heating for **more than the "Min. runtime to suppress summer mode 7035"**.
- or
- When the **"Last calendar week for summer mode 7036"** is reached.

Operation with external heat generator (not for compact appliances)

If the amount of energy in the ice store is no longer sufficient, the external heat generator can be switched on as an alternative energy source. To do this the dual mode temperature can be recorded via the temperature sensor in the ice store. The temperature sensor is switched by **"Temperature sensor for dual mode operation 7038"**.

Monitoring the absorber circuit

If a heat meter is installed in the absorber circuit and is connected to the Vitosolic, then **"Absorber circuit monitoring 7037"** can be used to start monitoring of the absorber circuit. If the amount of energy with active switching of the absorber circuit pump falls below 1 kWh within 6 h, the heat pump control unit displays the message **"96 Ice store absorber circ"**. In that case check the absorber circuit (e.g. absorber circuit pump faulty).

2-stage refrigerant circuit  [6]

The heat pump has a refrigerant circuit with 2 compressors connected in parallel but only one electronic expansion valve.

During times of low heat or cooling demand, only one compressor is in operation. If the heat or cooling demand increases, the 2nd compressor also switches on.

Required parameter settings

Parameter	Compressor 1	Compressor 2
"Enable compressor 5000"	"1"	
"Enable compr stage for tandem operation 509E"	"1"	"2"
	"3" (both compressors enabled)	
"Output compressor stage 5030"	Value according to rated heating output: See type plate.	
"Enable use of compressor stage 5012"	"0" to "15" For settings in the bit field: See page 194.	—
"Enable compr 2 for hydraulic circuit 509F"	—	"0" to "15" For settings in the bit field: See page 194.

Switching on the compressor

The refrigerant circuit controller always switches on the compressor that was **not** running most recently. This ensures that the runtimes of the two compressors remain balanced.

When the heat demand is low, only one compressor is in operation.

Switching on with 1 direct heating circuit without heating water buffer cylinder

With high output heat pumps, we recommend always using a heating water buffer cylinder **in the secondary circuit flow**.

In special cases, a direct heating circuit can also be supplied without a heating water buffer cylinder.

If **all** of the following conditions are met, compressor 1 starts:

- A heat demand is present. The secondary circuit return temperature undershoots the set value by 2 K.
- The blocking time of 20 min since the last compressor was started has expired.
- The blocking time of 5 min since stopping the most recently started compressor has expired.

If the heat demand still exists 20 min after compressor 1 was started, compressor 2 also starts.

Switching on with heating water buffer cylinder or DHW cylinder

The compressors are switched on under the following conditions:

- A heat demand is present. The set temperature of the relevant consumer is undershot by the corresponding start hysteresis:
 - Heating water buffer cylinder: **"Hysteresis temperature heating buffer cylinder 7203"**
 - DHW cylinder: **"Hysteresis DHW temperature heat pump 6007"**
- The blocking times (20 min/5 min) have expired: See previous chapter.

Switching off the compressor

Switching off with 1 direct heating circuit without heating water buffer cylinder

If the secondary circuit return temperature exceeds the set value by the stop hysteresis, first compressor 2 and then, after a short delay, compressor 1 switch off.

The compressors start according to the following system, depending on the output integral I_L :

System for compressor demand

Output integral I_L	Compressor	
	①	②
$I_L > 0.5$ times the "Start threshold 730E"	ON	OFF
$I_L > \text{"Start threshold 730E"}$	ON	ON

① Compressor 1: The compressor started first

② Compressor 2: The compressor started last

I_L Output integral: The integral of the duration and extent of the deviation between the set and actual return temperature in the secondary circuit
For further information on the output integral: See page 121.

2-stage refrigerant circuit ☒ [6] (cont.)

System for switching off the compressors

Output integral I_L	Compressor	
	①	②
$I_L < \text{"Start threshold 730E"}$	ON	ON
$I_L < 0.5$ times the "Start threshold 730E"	OFF	ON
$I_L = 0$	OFF	OFF

- ① Compressor 1: The compressor started first
 ② Compressor 2: The compressor started last
 I_L Output integral: The integral of the duration and extent of the deviation between the set and actual return temperature in the secondary circuit
 For further information on the output integral: See page 121.

Heat pump cascade ☒☒ / ☒

Note

Heat pump cascades are **not** possible with compact appliances and air/water heat pumps for indoor installation.

A heat pump cascade consists of a lead heat pump and up to 4 lag heat pumps. Each lag heat pump has 1 heat pump control unit.

The lead heat pump regulates operation of the heat pumps within the cascade. One or more heat pumps are started as and when required.

Note

Heat pumps with differing output can be combined with each other (not recommended for ☒☒).

Hydraulic connection versions

Type of hydraulic connection	Air/water heat pumps	
	☒	☒☒
Parallel at the secondary circuit and DHW cylinder flow: Each lag heat pump has its own secondary pump and circulation pump for cylinder heating, which are switched on by the lag heat pump when there is a demand from the lead heat pump.	X	—
Each via its own 3-way diverter valve "central heating/DHW heating", in parallel, in the secondary circuit flow: In addition, a further 3-way diverter valve is required in the return of each heat pump. ☒☒: The secondary pump and 3-way diverter valve are integrated in each indoor unit. ☒: For each heat pump, a 3-way diverter valve and a secondary pump are integrated into the secondary circuit flow. Changeover between central heating and DHW heating occurs in line with the demand made by the lead heat pump to the relevant lag heat pump.	X	X

Output-dependent operation

To operate the heat pump cascade in output-dependent mode, set "Output control strategy, cascade 700F" to "2".

The lead heat pump and lag heat pumps are switched on and off in a manner that ensures optimum COP for each heat pump.

Note

Output-dependent control is not possible with the Vitocal 300-A, type AWO 302.B.

Function description

Heat pump cascade ☒ / ☒ (cont.)

Detailed system schemes for heat pump cascades:
www.viessmann-schemes.com

Electrical connection and enabling

In a heat pump cascade the lead heat pump and lag heat pumps are linked into a LON.
 A LON communication module (accessories) must be installed in both the lead heat pump and the lag heat pump.

Depending on the system equipment level, all heat pumps in a cascade can be enabled separately for different functions ("**Enable use of compressor stage 5012**", "**Use of heat pump in cascade 700C**"):

- Central heating
- Central cooling
- DHW heating
- Swimming pool heating (priority: "**Priority external demand 7019**" set to "**1**")

Several functions can be activated.
 Individual heat pumps in the cascade can be in use for central heating/cooling, while at the same time others are heating DHW.

If no priority is set for the swimming pool ("**Priority external demand 7019**" on "**0**"): The swimming pool is only heated if there is no heat demand from the heating/cooling circuits and/or the buffer cylinder.

Flow temperature control for output-dependent operation

- The common flow temperature on the heating circuit side of the heat pump cascade is captured via the buffer outlet temperature sensor (connection F23 on controller and sensor PCB). This means the heat pumps of the cascade can be activated to allow for optimum COP.
- The buffer outlet temperature sensor is fitted on the heating circuit side, downstream of the buffer cylinder, close to the heating water flow connection.

Note

*If the heating circuit pumps are switched via a BMS (building management system), the buffer outlet temperature sensor must be installed **inside** the buffer cylinder, in close proximity to the heating water flow connection.*

Integrating a heat pump control unit into LON

Example of a heat pump cascade and Vitocom

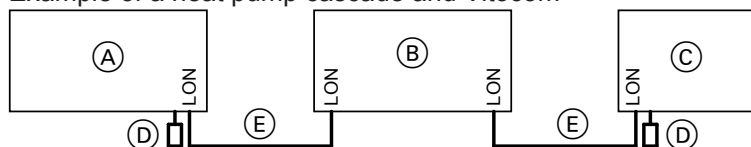

Fig. 8

- (A) Heat pump control unit, lead heat pump
- (B) Heat pump control unit, lag heat pump
- (C) Vitocom
- (D) Terminator
- (E) LON cable

Parameter settings

Parameter	(A) with output control	(A) without output control	(B)	(C)
"System scheme 7000"	"0" to "10"	"0" to "10"	"11"	—
"Enable use of compressor stage 5012"	"0" to "15"	"0" to "15"	—	—
"Cascade control 700A"	"2"	"2"	"0"	—
"Use of heat pump in cascade 700C"	—	—	"0" to "15"	—
"Runtime balance cascade 700D"	"0" / "1"	"0" / "1"	—	—
"Output control strategy, cascade 700F"	"2"	—	—	—
"Number of lag heat pumps 7029"	"1" to "4"	"1" to "4"	—	—
"Number of heat pump in cascade 7707"	—	—	"1" to "4"	—

Heat pump cascade ☒ / ☒ (cont.)

Parameter	Ⓐ with output control	Ⓐ without output control	Ⓑ	Ⓒ
LON communication module installed "Enable LON communication module 7710"	"1"	"1"	"1"	—
"LON system number 7798"	"1" to "5"	"1" to "5"	"1" to "5"	—
"LON subscriber number 7777" Each number may only be allocated once.	"1" to "99"	"1" to "99"	"1" to "99"	1 to 99
"LON fault manager 7779" Only one control unit per system may be configured as the fault manager.	"0" or "1"	"0" or "1"	"0" or "1"	Device is always the fault manager.
"Source time 77FE"	"0"	"0"	"1"	—
"Send time 77FF"	"1"	"1"	"0"	Device receives the time.
"Source outside temperature 77FC"	"0"	"0"	"1"	—
"Send outside temperature 77FD"	"1"	"1"	"0"	—
"Interval for data transfer via LON 779C"	"20"	"20"	"20"	—
"Enable buffer cylinder/low loss header 7200"	"1"	"1"	—	—
"Enable instantaneous heating water heater 7900"	"0" or "1"	"0" or "1"	"0" or "1"	—
"Enable electric heaters for DHW heating 6015"	"0" or "1"	"0" or "1"	—	—
"Enable electric heaters for DHW heating 7901"	—	—	"0" or "1"	—
"Enable instant. heating water heater for central heating 7902"	"0" or "1"	"0" or "1"	"0" or "1"	—
"Enable 3-way diverter valve heating/DHW 730D"	"1"	"0" or "1"	"0" or "1"	—

Calling up heat pumps

Only those heat pumps are called up that are enabled for the required use, e.g. DHW heating with **"Use of heat pump in cascade 700C"**.

Without runtime balance ("Runtime balance cascade 700D" set to "0")

If the return temperature in the secondary circuit is undershot by the start hysteresis, the heat pump control unit first activates the lead heat pump. Lag heat pumps are activated subject to output integral I_L (integral from duration and extent of deviation of set flow temperature from actual temperature in the secondary circuit).

Without runtime balance ("Runtime balance cascade 700D" set to "1")

Runtime balancing in cascades takes place between all lag heat pumps and the lead heat pump.

If the return temperature in the secondary circuit is undershot by the start hysteresis, the heat pump control unit activates the heat pump with the shortest runtime. This is not necessarily the lead heat pump. If further stages of the output integral are exceeded (n-times **"Start threshold 730E"**), one after the other the remaining heat pumps are called up, from the shortest runtime upwards.

Note on cascades with a 2-stage refrigerant circuit
The key factor for runtime balance in the cascade is the runtime of compressor 1. In every heat pump, the compressor that is started first is always the one that was **not** running most recently.

Function description

Heat pump cascade ☒ / ☒ (cont.)

Shutting down heat pumps

Lag heat pumps and/or compressors are shut down when the different stages of the output integral I_L (n-times "**Start threshold 730E**") are undershot, in reverse order to the starting sequence.

If the return temperature in the secondary circuit exceeds the set value by the stop hysteresis, the lead heat pump as well as all lag heat pumps are immediately stopped, irrespective of output integral I_L .

External functions

The following functions are available:

- External demand/external mixer OPEN or control function
- External changeover of operating status
- External blocking/external mixer CLOSE or control function

Note

The external functions are **not** possible in conjunction with the following functions:

- Smart Grid
- External hook-up for heating/cooling circuits
- ☒ / ☒: Cooling with heating water/coolant buffer cylinder

Overview of external functions

Connection

External demand	Operating status changeover	External blocking
<p>"External demand" signal:</p> <ul style="list-style-type: none"> ▪ X3.12/X3.13 on the cross connect PCB: See page 289. <p>or</p> <ul style="list-style-type: none"> ▪ X3.12/X3.13 on the luster terminals: See from page 292. <p>or</p> <ul style="list-style-type: none"> ▪ Via KM-BUS by the following devices: <ul style="list-style-type: none"> - EA1 extension (input DE3) - Vitocom 		<p>"External blocking" signal:</p> <ul style="list-style-type: none"> ▪ X3.2/X3.14 on the luster terminals: See page 292. <p>or</p> <ul style="list-style-type: none"> ▪ Via KM-BUS by the following devices: <ul style="list-style-type: none"> - EA1 extension (input DE2) - Vitocom <p>Note The "External blocking" signal takes priority over the "External demand" signal.</p>

Signal effects

External demand	Operating status changeover	External blocking
<ul style="list-style-type: none"> ▪ Switch on compressor. ▪ OPEN heating circuit mixer or control mode ▪ Regulate flow temperature in secondary circuit to a specified set flow temperature: See below. 	<p>Change the operating status of the following system components for a specific duration:</p> <ul style="list-style-type: none"> ▪ Heating circuits ▪ Buffer cylinder ▪ DHW cylinder ▪ Mechanical ventilation with connected ventilation unit 	<ul style="list-style-type: none"> ▪ Switch off compressor. ▪ CLOSE heating circuit mixer or control mode

External functions (cont.)

Secondary circuit set flow temperature

External demand	Operating status changeover	External blocking
<p>Note In systems incorporating a buffer cylinder the set buffer temperature is specified.</p> <p>System schemes 0 to 10:</p> <ul style="list-style-type: none"> ▪ According to "Set flow temperature external demand 730C" or ▪ Via analogue voltage signal at "0-10 V" input of EA1 extension: 0 to 10 V corresponds to 0 to 100 °C in the delivered condition. Connect terminals with jumper at input DE3. <p>The higher value is used.</p> <p>System scheme 11:</p> <ul style="list-style-type: none"> ▪ Max. flow temperature in the secondary circuit (100 % output demand) 	<p>Highest flow temperature resulting from the currently applicable operating status of the system components.</p>	<p>No set value specified</p> <p>Note Frost protection is not ensured. Enabled booster heaters will not be switched on.</p>

Parameter settings

External demand	Operating status changeover	External blocking
<ul style="list-style-type: none"> ▪ "System scheme 7000" set to "0" to "10" ▪ "Effect of external demand on heat pump/heating circuits 7014" ▪ "Priority external demand 7019" 	<ul style="list-style-type: none"> ▪ "System scheme 7000" set to "0" to "10" ▪ "System components for external changeover 7011" ▪ "Operating status for external changeover 7012" ▪ "Effect of OM changeover to ventilation 701F" ▪ "Duration of external changeover 7013" 	<ul style="list-style-type: none"> ▪ "System scheme 7000" set to "0" to "10" ▪ "Effect of ext. blocking on heat pump/heating circuits 7015" ▪ "Effect of external blocking on pumps/compressor 701A"

External hook-up for heating/cooling circuits

The demand for central heating or cooling can be activated for every heating/cooling circuit, e.g. by a Smart Home system.

Connection

The signal for the demand is switched via the 230 V~ digital inputs on the main PCB, plugs [214](#) and [216](#):
See chapter "Main PCB".

Parameter settings

In order to enable the external hook-up for the relevant heating/cooling circuit, set **"Remote control 2003, 3003, 4003"** to **"2"**.

External hook-up for heating/cooling circuits (cont.)

Enabling this has the following effects on the functions of the heat pump control unit:

- The time programs for central heating/cooling for the relevant heating/cooling circuit are disabled. The other time programs are active, e.g. **"Time program DHW"**.
- The set room temperatures for the individual heating circuits are **"Standard room temperature 2000, 3000, 4000"**.
- External functions are **not** available: External demand, operating status changeover, external blocking
- Smart Grid is only possible via the EA1 extension (**"Enable Smart Grid 7E80"** set to **"1"**), **not** via the digital inputs on the main PCB (**"Enable Smart Grid 7E80"** set to **"4"**).
- Operation via remote control **not** possible
- Integration into Vitocomfort 200 **not** possible

Signal effects

Central heating/cooling is switched on **permanently** regardless of the heating limit and cooling limit: See chapters "Heating limit" and "Cooling limit".

Note

If demands for central heating and cooling are present simultaneously, the demand for central heating takes priority.

Set flow temperatures

The set flow temperature for a heating circuit comprises the heating/cooling curve set for this heating circuit and the value set for **"Standard room temperature 2000"**. If demands for central heating are issued by several heating circuits at once, the highest set flow temperature is used in the secondary circuit flow.

Power-OFF

Frequently, economy tariffs for electricity include an agreement that the electrical supply for compressors and instantaneous heating water heaters can be suspended by the power supply utility several times each day. The heat pump control unit receives the power-OFF signal via terminals X3.6/X3.7 on the cross connect PCB or luster terminals (floating contact required). To safeguard the remaining functions of the heating system during the power-OFF period, the power supply of the heat pump control unit must **not** be switched off. The heat pump control unit must therefore be connected to an unblockable power supply.

Note

*The power-OFF signal must **not** be connected in the following cases:*

- *In conjunction with a photovoltaic system (utilisation of power generated on site)*
- *In connection with Smart Grid*

Connection versions

■ Without on-site load disconnect:

The compressor is shut down by the heat pump control unit. The instantaneous heating water heater (if installed) can remain in operation (**"Output for instant. heating water heater at power-OFF 790A"**).

The power OFF signal is only connected to the lead heat pump in heat pump cascades.

■ With on-site load disconnect:

The compressor and instantaneous heating water heater are "forced" OFF.

With heat pump cascades, the power-OFF signal is connected to **all** heat pumps in parallel and **in the same phase** via a contactor relay.

Smart Grid

The Smart Grid functions are used to match heat pump operation to the available energy in the grid. To enable Smart Grid, set **"Enable Smart Grid 7E80"** to **"1"** or **"4"**.

If there is only a small amount of energy in the grid, the heat pump can be blocked. If there is excess energy, the power supply utility can specifically issue a demand for the heat pump.

- Smart Grid functions are switched on via 2 floating contacts of the power supply utility.
- Connection options for the two floating contacts:
 - At the EA1 extension in accordance with Fig. 9
 - At the heat pump control unit in accordance with Fig. 36

Connection to EA1 extension

Requirement: **"Enable Smart Grid 7E80"** set to **"1"**.

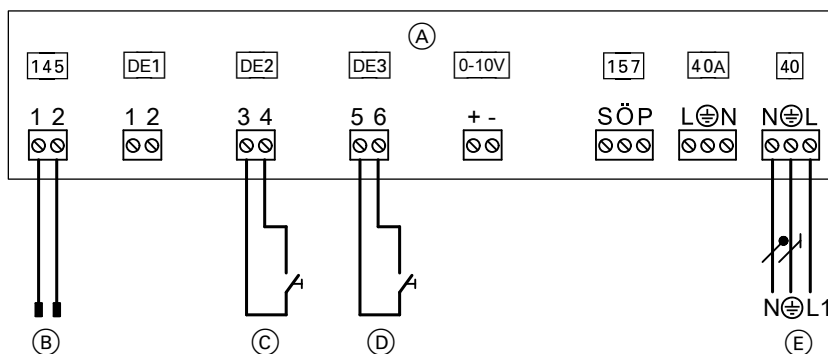

Fig. 9

- (A) EA1 extension
- (B) KM-BUS connection to the controller and sensor PCB
- (C) Floating contact 1: The agreement of the power supply utility may be required
- (D) Floating contact 2: The agreement of the power supply utility may be required
- (E) Power supply 1/N/PE 230 V/50 Hz

Note

- If Smart Grid is enabled (**"Enable Smart Grid 7E80"** set to **"1"**), both inputs DE2 and DE3 **cannot** be used for signals "External demand" or "External blocking".
- The power-OFF function is integral to Smart Grid. The power-OFF signal must therefore **not** be connected to connections X3.6 and X3.7.

Connection to heat pump control unit

Requirement: "Enable Smart Grid 7E80" set to "4".

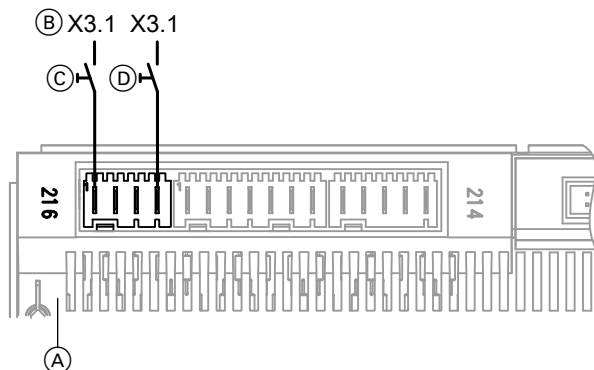

Fig. 10

- (A) Main PCB
- (B) Connection X3.1 (L') at the luster terminals
- (C) Floating contact 1: The agreement of the power supply utility may be required
- (D) Floating contact 2: The agreement of the power supply utility may be required

Note

- If the Smart Grid is connected to the two digital inputs on the main PCB ("Enable Smart Grid 7E80" set to "4"), the external hook-up for the heating/cooling circuits must not be switched on ("Remote control 2003" set to "2"). Otherwise, the Smart Grid is not active.
- The power-OFF function is integral to Smart Grid. The power-OFF signal must therefore **not** be connected to connections X3.6 and X3.7.

Functions

Floating contact		Function
1 (C)	2 (D)	
○	○	① Heat pump in standard mode
X	○	② Power-OFF <ul style="list-style-type: none"> ▪ Compressor OFF ▪ The instantaneous heating water heater can be switched ON ("Output for instant. heating water heater at power-OFF 790A").
○	X	③ Operation of the heat pump with adjusted set temperatures for different functions. The modifications are adjusted with the following parameters: <ul style="list-style-type: none"> ▪ DHW heating: "Smart Grid set value increase for DHW heating 7E91" ▪ Buffer cylinder heating: "Smart Grid set value increase for htg wtr buff 7E92" ▪ Central heating: "Smart Grid set value increase for centr htg 7E93" ▪ Central cooling: "Smart Grid set value decrease for room t cool 7E95" <ul style="list-style-type: none"> ▪ The compressor only starts when there is a demand. The applicable start conditions for the relevant function must be met. A time phase must be active in time program for the relevant function. ▪ The adjusted set temperatures do not affect the booster heaters. The booster heaters are switched off at the limits that apply without Smart Grid.

Smart Grid (cont.)

Floating contact		Function
1 (C)	2 (D)	
X	X	<p>④ System components are heated to the set max. temperatures or cooled to the minimum temperatures. The compressor starts immediately, even when no time phase is active in the time program.</p> <p>Max. temperatures for different functions:</p> <ul style="list-style-type: none"> ▪ DHW heating: "Max. DHW temperature 6006" ▪ Buffer cylinder heating: "Max. temperature buffer cylinder 7204" ▪ Central heating: "Max. flow temperature heating circuit 200E" ▪ Central cooling: "Min. flow temperature cooling 7103" <ul style="list-style-type: none"> ▪ The instantaneous heating water heater may be switched on to reach the max. temperatures. The max. stage can be selected ("Smart Grid Enable elec heat 7E82"). ▪ The max. set temperatures do not affect the remaining booster heaters, e.g. external heat sources. The booster heaters are switched off at the limits that apply without Smart Grid. ▪ The system components are heated or cooled in sequence according to the specified priorities, e.g. DHW heating before central heating. ▪ The "Shutdown limit, heat pump dual mode 7B0F" is shifted to -30 °C, so that the heat pump will remain in operation, even at low outside temperatures.

X Contact active

○ Contact not active

Information regarding functions ③ and ④

- As excess power is being consumed, the consumption of electrical power is **disregarded** when calculating the seasonal performance factor.
- Set temperatures can also be adjusted when utilising power generated on site. If utilisation of power generated on site and function ③ are active at the same time, the higher set value adjustment applies: See chapter "Photovoltaics".

Booster heaters

Central heating

An instantaneous heating water heater and/or an external heat source can be used as the booster heater for central heating. Both appliances are controlled by the heat pump control unit. "**Priority ext. heat source/instant. heating water heater 7B01**" specifies which heat source the heat pump control unit switches on first in the event of increased heat demand in the heating circuits.

Note

The use of an instantaneous heating water heater and/or an external heat source is not possible for all heat pumps.

DHW reheating

See chapter "DHW reheating with booster heaters" on page 42.

External heat generator

The heat pump control unit enables dual mode operation of the heat pump with an external heat source, e.g. oil boiler.

The external heat generator is hydraulically connected in such a way that the heat pump can also be used as a return temperature raising facility for the boiler. System separation is provided with either a low loss header or a buffer cylinder.

For optimum heat pump operation, the external heat generator must be integrated into the system flow downstream from the buffer cylinder via a mixer. The heat pump control unit controls this mixer directly. The external heat generator is switched via a floating contact (terminals 222.3/222.4 on the expansion PCB).

Central heating

Enabling required

Parameter	Setting
"Enable external heat source 7B00"	"1"
"Enable external heat gen. for central heating 7B0C"	"1"

■ **Dual mode operation**

The heat pump control unit enables operation of the external heat generator for central heating if the adjusted outside temperature ("Interval for long term average outside temperature 7002") is below the "Dual mode temperature external heat source 7B02".

Above the dual mode temperature, the external heat generator only starts under the following conditions:

- The heat pump fails to start due to a fault.
- or
- There is a special heat demand, e.g. frost protection.

■ **Dual mode operation**

Possible operating modes for the external heat generator ("Dual mode heat pump operation 7B0E"):

- Dual mode parallel:
External heat generator and heat pump are switched on simultaneously.
- Dual mode alternative:
Compressor stops when the external heat generator is switched on.

In most cases, dual mode parallel operation is more efficient than dual mode alternative operation. With low outside temperatures it may be more advantageous, subject to heat pump type, to only permit dual mode alternative operation ("Shutdown limit, heat pump dual mode 7B0F").

■ **Dual mode operation with ice store** □

If an ice store is available as a primary source, the external heat generator can also be enabled subject to the temperature in the ice store. For this, the dual mode temperature must be captured via the temperature sensor in the ice store ("Temperature sensor for dual mode operation 7038" set to "1").

■ **Start criteria**

The system flow temperature is crucial for the starting of the external heat generator. In order to prevent brief undershooting of the set value resulting in the immediate start of the external heat generator, the output integral is used as start criterion (integral resulting from the duration and amount of the deviation between the set and actual flow temperature: "Start threshold external heat source 7B03").

In the following cases, the start of the external heat generator will be prevented for the duration of "Start delay external heat source 7B04":

- After a change in the "Time program heating" from one operating state with low set temperature to a higher set temperature, e.g. from "Reduced" to "Standard"
- After changeover between central heating and DHW heating

■ **Regulating the system flow temperature**

The mixer for linking in the external heat generator remains closed until the boiler water temperature of the external heat generator has reached "Min. flow temperature mixer external heat source ON 7B05". This prevents cold heating water from the external heat generator reaching the heating circuits. After opening, the mixer regulates towards the set flow temperature of the system.

■ **Mixer for external heat generator**

If the boiler water temperature of the external heat generator falls below the "Min. flow temperature mixer external heat source ON 7B05" when a demand is present, "Enable min. temp. maintenance for ext. HS 7B10" can be used to adjust the following characteristics for the mixer:

- The mixer remains in control mode until the demand for the external heat generator is no longer present.
- Mixer closes. The mixer only opens again when "Min. flow temperature mixer external heat source ON 7B05" is reached.

To compensate for heat losses at the mixer, "Max. excess flow temp external heat source 7B0B" can be used to raise the flow temperature of the external heat generator compared to the required set flow temperature of the system.

■ **In the event of a fault**

If "Min. flow temperature mixer external heat source ON 7B05" has not been reached 2 h after starting the external heat generator, the heat pump control unit issues the fault message "E1 External heat source".

Booster heaters (cont.)

■ Stop criteria

The heat pump control unit switches the external heat generator off if **both** of the following conditions are met:

- **"Min. runtime external heat source 7B06"** has expired.
- The system flow temperature is above the set value for the duration of **"Run-on time external heat source 7B07"**.

DHW reheating

See chapter "DHW reheating with booster heaters" on page 42.

Safety functions

To protect the heat pump against excessive flow and return temperatures, the heat pump control unit does **not** contain any safety functions for the external heat generator.

For this reason, the following high limit safety cut-outs (respective switching threshold 70 °C) must be used.

■ Central heating:

Provide **2** high limit safety cut-outs in the following positions:

- Flow secondary circuit, upstream of the instantaneous heating water heater (if installed)
- Secondary circuit return (between heat pump and buffer cylinder)

Both high limit safety cut-outs must be connected electrically so that, in each case, the external heat generator **and** the secondary pump are switched off.

Note

- *The secondary pump does not start if the return temperature in the secondary circuit exceeds 67 °C.*
- *The compressor does not start, if at the end of "Start delay compressor 5008" the return temperature in the secondary circuit lies above the max. flow temperature in the secondary circuit minus 7 K.*

■ DHW reheating:

Provide **1** high limit safety cut-out in the following position:

- Return secondary circuit (between heat pump and DHW cylinder)

Connect the high limit safety cut-out electrically so that either the circulation pump for cylinder reheating is switched off **or** the 3-way diverter valve "Heating/DHW" is set to "Heating".

Frost protection

If the boiler water temperature falls below 5 °C, the heat pump control unit switches on the external heat generator for the duration **"Min. runtime external heat source 7B06"**.

Instantaneous heating water heater

An electric instantaneous heating water heater can be integrated in the secondary circuit flow as an auxiliary heat source.

Depending on the heat pump type, the instantaneous heating water heater is either factory-fitted or available as an accessory.

Subject to heat demand, 2 output stages (e.g. 3 and 6 kW) of the instantaneous heating water heater can be controlled separately. When there is a high heat demand, the heat pump control unit can activate both stages simultaneously, e.g. 3 kW + 6 kW = 9 kW, (\neq output stage 3).

The output stage can be limited permanently with **"Max. output instantaneous heating water heater 7907"**. In order to be able to cover a possible high heat demand every time the heat pump is switched on, this limit will not be effective immediately after the heat pump starts.

To limit the total power consumption, the heat pump control unit switches off the instantaneous heating water heater for a few seconds directly before the compressor starts. Each stage is subsequently started individually one after the other at intervals of 10 s. The instantaneous heating water heater can be called for to support both central heating and DHW heating. There are individual criteria options for each mode.

Booster heaters (cont.)

Note

The fault message **"AB Instant.htg wtr heater"** is displayed if the instantaneous heating water heater is called for and the differential between flow and return temperatures in the secondary circuit does not increase by at least 1 K within 24 h.

Central heating

Enabling required

Parameter	Setting
"Enable instantaneous heating water heater 7900"	"1"
"Enable instant. heating water heater for central heating 7902"	"1"

! **Please note**
 After the value "1" has been set for **"Enable instantaneous heating water heater 7900"**, the prompt **"Secondary circuit filled?"** automatically appears. If this prompt is responded to with **"No"**, the instantaneous heating water heater will not be enabled. Set **"Enable instantaneous heating water heater 7900"** to **"2"**. Fill the secondary circuit. Confirm prompt **"Secondary circuit filled?"** with **"Yes"**.

The instantaneous heating water heater can only be started for central heating if **all** of the following conditions are met:

- Operation of the instantaneous heating water heater is enabled as per **"Time prog elec heater"**.

 "Vitotronic 200" operating instructions

- Adjusted outside temperature falls below **"Dual mode temp instant. heating water heater 790B"**.
- The secondary circuit **flow temperature** undershoots the set value by 2 K.

Note

Vitocal 300-A, type AWO 302.B:
 The secondary circuit **return temperature** undershoots the set value by 2 K.

- **"Start threshold 730E"** exceeded.
- **"Start delay instantaneous heating water heater 7905"** e.g. after changing the operating status expired.

Subject to how much the **"Start threshold 730E"** has been exceeded, different stages of the instantaneous heating water heater are switched on.

Note

As frost protection for the heating circuits or the buffer cylinder, the instantaneous heating water heater will also be switched on if **none** of the above criteria is met.

Switching off the instantaneous heating water heater

- For direct heating circuits (without buffer cylinder):
 Under the following conditions, the heat pump control unit switches off the individual stages of the instantaneous heating water heater in succession:
 The secondary circuit **flow temperature** exceeds the set flow temperature.

Note

Vitocal 300-A, type AWO 302.B:
 The secondary circuit **return temperature** exceeds the set return temperature.

- Heating circuits with mixer (with buffer cylinder):
 If the **return temperature** in the secondary circuit exceeds the set buffer temperature, the heat pump control unit switches the instantaneous heating water heater off.

DHW reheating

See chapter "DHW reheating with booster heaters" on page 42.

DHW heating

DHW heating by the heat pump

In the delivered condition, DHW heating by the heat pump takes priority over central heating/cooling. This setting can be changed by a heat pump installer certified by Viessmann.

If DHW priority has been set, and there is a simultaneous heat demand for heating circuits and the DHW cylinder, the DHW cylinder is heated only for the duration of **"Max. runtime DHW heating in heating mode 6011"**. If the heat demand from the DHW cylinder is then still active, heating circuits will only be supplied for the duration of **"Max. interruption of DHW heating for central heating 6012"**.

DHW heating (cont.)

The DHW circulation pump remains off during DHW heating in order to prevent the DHW inside the DHW cylinder being mixed.

Switching DHW heating on and off

If the temperature at the start temperature sensor falls below the current set DHW temperature by more than "**Hysteresis DHW temperature heat pump 6007**", DHW heating starts. DHW heating ends if the temperature at the stop temperature sensor rises above the set DHW temperature or as soon as "**Max. DHW temperature 6006**" is reached.

1 cylinder temperature sensor, installation in top of DHW cylinder

	Operating status in DHW time program			One-off DHW heating
	"Top"	"Standard"	"Temp. 2"	
▪ Cylinder temperature sensor, top	ON OFF	ON OFF	ON OFF	ON OFF
Set cylinder temperature	"Set DHW temperature 6000"		"Set DHW temperature 2 600C"	

ON Starts DHW heating.
OFF Stops DHW heating.

2 cylinder temperature sensors, installation in top and bottom of DHW cylinder

	Operating status in DHW time program			One-off DHW heating
	"Top"	"Standard"	"Temp. 2"	
▪ Cylinder temperature sensor, top	ON OFF	ON	ON	ON
▪ Cylinder temperature sensor, bottom	—	OFF	OFF	OFF
Set cylinder temperature	"Set DHW temperature 6000"		"Set DHW temperature 2 600C"	"Set DHW temperature 6000"

ON Starts DHW heating.
OFF Stops DHW heating.

Note

The bottom cylinder temperature sensor must be enabled with "**Temperature sensor at bottom of DHW cylinder 600E**".

**Operating status**

"Vitotronic 200" operating instructions

Blocking time for DHW heating

A blocking time for DHW heating can be specified with "**Blocking time DHW heating 6060**". Once the DHW cylinder has been fully heated, DHW heating will **not** be switched on during the specified blocking time, even if the cylinder temperature undershoots the set temperature by "**Hysteresis DHW temperature heat pump 6007**" during this blocking time.

Note

If too long a blocking time is set and DHW consumption is high, the cylinder temperature may fall too far.

Max. pause duration for DHW heating

"**Max. interruption DHW heating 6061**" determines the longest pause duration before the next period of DHW heating. When the DHW cylinder has been fully heated, DHW heating will start again in any case once this pause duration has expired. This applies even if the cylinder temperature has **not** undershot the set temperature by the "**Hysteresis DHW temperature heat pump 6007**".

Note

If "**Max. interruption DHW heating 6061**" is set to a shorter period than "**Blocking time DHW heating 6060**":

The set blocking time will have no effect. Provided that the stop temperature for the DHW cylinder is undershot, DHW heating will start once the "**Max. interruption DHW heating 6061**" has expired. This applies even if the start temperature for DHW heating has **not** been undershot.

DHW reheating with booster heaters

Possible booster heaters:

- Instantaneous heating water heater (part of standard delivery, as accessory or on site, depending on heat pump type)
 - External heat generator
- or**
- Immersion heater (as an accessory or on site, depending on heat pump type), installed in the DHW cylinder

Note

*An immersion heater and an external heat generator **cannot be enabled simultaneously** for DHW reheating.*

Enabling for DHW reheating

Parameter	Instantaneous heating water heater	Immersion heater	External heat generator
"Enable booster heaters for DHW heating 6014"	—	"1"	—
"Enable electric heaters for DHW heating 6015"	"1"	"1"	—
"Enable instantaneous heating water heater 7900"	"1"	—	—
"Enable external heat source 7B00"	—	—	"1"
"Enable external heat source for DHW heating 7B0D"	—	—	"1"



Please note

After the value "1" has been set for "**Enable instantaneous heating water heater 7900**", the prompt "**Secondary circuit filled?**" automatically appears. If this prompt is responded to with "**No**", the instantaneous heating water heater will not be enabled. Set "**Enable instantaneous heating water heater 7900**" to "2". Fill the secondary circuit. Confirm prompt "**Secondary circuit filled?**" with "**Yes**".

Switching DHW reheating on and off

The enabled booster heater is switched on and off for DHW reheating subject to parameter "**Enable elec. heating/ext. HS for reheating only 6040**", under the following conditions:

If several booster heaters have been enabled for DHW reheating, the integral load management of the heat pump control unit decides which of the booster heaters is activated. The external heat generator has priority over the instantaneous heating water heater.

DHW heating (cont.)**DHW reheating ON**

"Enable elec. heating/ext. HS for reheating only 6040" = "0"	"Enable elec. heating/ext. HS for reheating only 6040" = "1"
<p>All of the following criteria must be met:</p> <ul style="list-style-type: none"> ▪ The cylinder temperature falls below the current set value by "Hysteresis DHW temperature booster heater 6008". ▪ "Temperature rise per hour for DHW heating 600D" is not being reached with DHW heating by the heat pump. ▪ General operating conditions for the respective booster heater are met. <p>The compressor stays switched on during DHW reheating.</p>	<p>One of the following criteria must be met:</p> <ul style="list-style-type: none"> ▪ Max. flow temperature in the secondary circuit has been reached. ▪ There is a fault in the heat pump. ▪ The compressor was switched off externally, e.g. during power-OFF. <p>The compressor stays switched off during DHW reheating.</p>

DHW reheating OFF

"Enable elec. heating/ext. HS for reheating only 6040" = "0"	"Enable elec. heating/ext. HS for reheating only 6040" = "1"
<p>Instantaneous heating water heater:</p> <ul style="list-style-type: none"> ▪ Set cylinder temperature has been reached. <p>or</p> <ul style="list-style-type: none"> ▪ The flow temperature in the secondary circuit reaches the max. flow temperature less the "Shutdown hysteresis inst. heating water heater 601E". <p>External heat generator/immersion heater:</p> <ul style="list-style-type: none"> ▪ The set cylinder temperature less the hysteresis of 1 K has been reached, measured at the upper cylinder temperature sensor. 	<p>Set cylinder temperature has been reached.</p>

Solar DHW heating

Solar DHW heating can be controlled via the solar control module, type SM1.



Installation and service instructions "Solar control module, type SM1"

Frost protection

The heat pump control unit starts the booster heaters when the temperature at the cylinder temperature sensor falls below 3 °C:

- Instantaneous heating water heater (part of standard delivery, as accessory or on site, depending on heat pump type)
- External heat generator
- Immersion heater (as an accessory or on site, depending on heat pump type)

Note

To protect the DHW cylinder against frost, the heat pump control unit switches the immersion heaters on even when they are disabled for DHW heating (**"Enable electric heaters for DHW heating 6015"** set to **"0"**).

Heating for frost protection ends if the temperature at the top cylinder temperature sensor exceeds 10 °C.

Buffer cylinder

Provision **must** be made for a buffer cylinder in the case of heating/cooling circuits with mixer.

Exception: If the installation kit with mixer (accessories) is installed in a heat pump compact appliance, the heating circuit with mixer M2/HC2 can be connected directly (**"Type of assembly kit 7044"** set to **"1"**). In this case, the parameters for the buffer cylinder cannot be adjusted.

Function description

Buffer cylinder (cont.)

Functions

- For bridging power-OFF periods:
The buffer cylinder supplies the heating/cooling circuits including during this power-OFF time.
- For the hydraulic separation of the secondary circuits and the heating/cooling circuits: For example, if the flow rate in the heating/cooling circuits is reduced by thermostatic valves, the flow rate in the secondary circuit remains constant.
- Longer heat pump operating times
The greater water volume and possible separate shutting-off of the heat generator make the provision of an additional or larger expansion vessel necessary.

Protect the heat pump in accordance with EN 12828.

Note

For heating or cooling of the buffer cylinder and the heating/cooling circuits connected to it, the flow rate on the secondary side must be split inside the buffer cylinder. The secondary pump flow rate must therefore be greater than the total flow rate of all heating circuit pumps.

Overview of buffer cylinders

A distinction is made between heating water buffer cylinders and heating water/coolant buffer cylinders in terms of equipment and function.

Equipment/function	Heating water buffer cylinder	Heating water/coolant buffer cylinder ☒☐
Hydraulic connection to the system	Parallel in secondary circuit flow	Parallel in secondary circuit flow
Central heating	X	X
Central cooling	Heating water buffer cylinder is bypassed in cooling mode by means of the hydraulic bypass circuit.	X
Enable with "Enable buffer cylinder/low loss header 7200"	"1" Only central heating	"1" Only central heating "2" Central heating and central cooling
Number of heating circuits	Max. 3	Max. 3
Number of cooling circuits	Max. 1	Max. 3
Separate cooling circuit	X	—
Parameter for central cooling	Only "71xx"	"Cooling function 7100" A1/HC1 "20xx" M2/HC2 "30xx" M3/HC3 "40xx"
Cooling functions	Natural cooling, active cooling	Active cooling
Changeover between heating and cooling mode	Automatic, as in cooling mode, the heating water buffer cylinder is bypassed by means of the hydraulic bypass circuit.	Manual with "Buffer cyl operating mode 721F"
Buffer temperature sensor	Installed at top, connection to F4 on controller and sensor PCB	Installed at top, connection to F4 on controller and sensor PCB

Buffer cylinder (cont.)**Buffer cylinder in conjunction with heat pump cascade**   / 

To ensure stratification in the upper section of the buffer cylinder in heating mode, allocate the buffer cylinder connections as follows:

- Connect the secondary flow from the heat pump cascade to one of the centre connectors of the buffer cylinder.
- Connect the heating/cooling circuit flow to the top connector of the buffer cylinder.

Heating the buffer cylinder with the heat pump

Applicable to:

- Heating water buffer cylinder
- Central heating with heating water/coolant buffer cylinder

Heating is deactivated if the temperature at the stop temperature sensors rises above the stop temperature or as soon as **"Max. temperature buffer cylinder 7204"** is reached.

Switching heat-up on and off

If the buffer temperature falls below the current set buffer temperature by more than **"Hysteresis temperature heating buffer cylinder 7203"**, heating of the buffer cylinder is activated. The current set buffer temperature is always the highest set flow temperature of all connected heating circuits.

Note

In the event of a fault in the buffer temperature sensor, heating of the buffer cylinder is stopped immediately.

Operating status in time program for buffer cylinder	Buffer cylinder heating	
	ON	OFF
"Top"	Set buffer temperature less "Hysteresis temperature heating buffer cylinder 7203" at buffer temperature sensor is undershot.	<ul style="list-style-type: none"> ▪ Set buffer temperature plus "Stop hysteresis, buffer cylinder 7209" at buffer temperature sensor is exceeded. ▪ If no buffer temperature sensor is installed, the secondary circuit return temperature sensor is used.
"Standard"		<ul style="list-style-type: none"> ▪ Set buffer temperature at buffer temperature sensor is exceeded. and ▪ Set buffer temperature plus "Stop hysteresis, buffer cylinder 7209" at secondary circuit return temperature sensor is exceeded.
"Fixed value"		<ul style="list-style-type: none"> ▪ "Temp in operating status fixed value for buffer cyl 7202" at buffer temperature sensor is exceeded. and ▪ "Temp in operating status fixed value for buffer cyl 7202" plus "Stop hysteresis, buffer cylinder 7209" at secondary circuit return temperature sensor is exceeded.

Note

*The operating status "Fixed value" can be blocked for the buffer cylinder if there is no heat demand from any of the connected heating circuits (**"Operating mode, fixed value only for heat demand 720A"** set to "1"). In such cases, the buffer cylinder is only heated to the set temperature for operating status "Standard".*

**Operating status**

"Votronic 200" operating instructions

Buffer cylinder (cont.)

Heating the buffer cylinder with booster heaters

Only the instantaneous heating water heater can be used as a booster heater for the buffer cylinder, as it is integrated hydraulically into the flow of the secondary circuit.

The external heat generator is integrated into the system flow via a mixer, downstream of the buffer cylinder. This results in a direct heating of the heating circuits. The buffer cylinder is heated by the external heat generator indirectly via the heating circuit return.

For heating the buffer cylinder with an instantaneous heating water heater: See page 40.

Stop optimisation

The stop optimisation ("**Stop optimisation heating buffer cylinder 7205**" set to "**1**") ensures that the set buffer cylinder temperature is always reached at the end of a time phase with the operating status "**Standard**".

Therefore, the heating of the buffer cylinder starts earlier by the required heat-up time, even if the start conditions have not yet been met. The heat-up time is automatically set to between 0.5 and 2 h, subject to the heat-up times of the previous few days.

Cooling of the heating water/coolant buffer cylinder   / 

Note

*Does **not** apply to central cooling if a heating water buffer cylinder for central cooling is bypassed by means of a hydraulic bypass circuit.*

Cooling of the heating water/coolant buffer cylinder ends if the temperature at the stop temperature sensors drops below the stop temperature or as soon as "**Min. temperature coolant buffer cylinder 722A**" is reached.

Switching cooling on and off

If the buffer temperature exceeds the current set buffer temperature by more than "**Start hysteresis coolant buffer cylinder 722B**", cooling of the buffer cylinder is activated. The current set buffer temperature is always the lowest set flow temperature of all connected cooling circuits. The set buffer temperature is limited to "**Min. temperature coolant buffer cylinder 722A**" even if a lower value is calculated for one of the connected cooling circuits.

Note

In the event of a fault in the buffer temperature sensor, cooling of the heating water/coolant buffer cylinder is stopped immediately.

Buffer cylinder (cont.)

Operating status in time program for buffer cylinder	Buffer cylinder cooling	
	ON	OFF
"Top"	Set buffer temperature plus "Start hysteresis coolant buffer cylinder 722B" at buffer temperature sensor is undershot.	Set buffer temperature minus "Stop hysteresis coolant buffer cylinder 7223" at buffer temperature sensor is undershot.
"Standard"	Set buffer temperature plus "Start hysteresis coolant buffer cylinder 722B" at buffer temperature sensor is exceeded.	<ul style="list-style-type: none"> ▪ Set buffer temperature at buffer temperature sensor is undershot. and ▪ Set buffer temperature minus "Stop hysteresis coolant buffer cylinder 7223" at secondary circuit return temperature sensor is undershot.
"Fixed value"		<ul style="list-style-type: none"> ▪ "Temp in op. status fixed value for coolant buff cyl. 7220" at buffer temperature sensor is undershot. and ▪ "Temp in op. status fixed value for coolant buff cyl. 7220" minus "Stop hysteresis, buffer cylinder 7209" at secondary circuit return temperature sensor is undershot.



Operating status

"Vitotronic 200" operating instructions

Frost protection

If the buffer temperature falls below the frost protection limit, the heat pump control unit immediately switches on the heat pump and the instantaneous heating water heater.

Any activated block of the instantaneous heating water heater for the central heating becomes ineffective (**"Enable instant. heating water heater for central heating 7902"** set to "0").

Frost protection heating ends when the buffer temperature exceeds the stop limit.

Temperature limit	Central heating with heating water buffer cylinder or heating water/coolant buffer cylinder	Room cooling with heating water/coolant buffer cylinder ☒ / ☒
Frost protection limit	3 °C	3 °C
Shutdown limit	10 °C	6 °C

Low loss header

For the hydraulic separation of the secondary circuits and the heating circuits.

The heat pump control unit treats a low loss header in the same way as a small heating water buffer cylinder. In the heat pump control unit, the low loss header must therefore be configured as a heating water buffer cylinder (**"Enable buffer cylinder/low loss header 7200"**).

The buffer temperature sensor is installed either in the low loss header or downstream of the low loss header in the system flow.

Note

To ensure that as much of the return temperature of the heating circuits as possible is transferred to the return of the secondary circuit, the flow rate on the heating circuit side must be higher than the heat pump flow rate on the secondary side.

Heating circuits/cooling circuits

Notes on minimum flow rate

Heat pumps require a minimum flow rate in the secondary circuit, which **must** be maintained.

Note

With brine/water heat pumps a minimum flow rate must also be maintained on the primary side.



Minimum flow rates

Installation and service instructions of the relevant heat pump

System with small water volumes, e.g. heating systems with radiators

To avoid excessive compressor cycling (starting/stopping), the heating system volume must be increased.

This can be achieved by using buffer cylinders as follows:

- Buffer cylinder connected in parallel to the heating circuits with a volume matched to the heat pump output.
- Heating water buffer cylinder connected in series in the secondary circuit return or pre-cooling vessel with small volume, e.g. 50 l.

With air/water heat pumps, a higher system volume ensures that the thermal energy required for defrosting is always available in the secondary circuit.



Minimum heating system volume

"Technical guides for heat pumps"

Systems with large water volumes, e.g. underfloor heating systems

Systems with large water volumes can operate without a buffer cylinder. In these heating systems, install an overflow valve at the heating circuit distributor of the underfloor heating system that is furthest away from the heat pump. This guarantees the minimum flow rate, even when the thermostatic valves are closed.

Note

*A buffer cylinder connected in parallel **must always** be used in the case of heating circuits with mixers.*

Exception : *If the installation kit with mixer (accessories) is installed in a heat pump compact appliance, the heating circuit with mixer M2/HC2 can be connected directly ("**Type of assembly kit 7044**" set to "**1**").*

System configurations

The heat pump control unit can switch 1 heating circuit without mixer (A1/HC1) and **up to** 2 heating circuits with mixer (A2/HC2, A3/HC3).

In combination with a heating water/coolant buffer cylinder, it is able to cool 3 heating circuits simultaneously.

If just a heating water buffer cylinder is installed in the heating system, **one** of the 3 heating circuits can be used for cooling (as a heating/cooling circuit) **or** a separate cooling circuit can be switched ("**Cooling circuit 7101**").

Note

If a separate cooling circuit is connected, cooling can not take place via a heating/cooling circuit.

Heating circuits/cooling circuits (cont.)

Overview of the heating/cooling circuits

Heating/cooling circuit	Controlled directly		Controlled via KM-BUS M3/HC3	Separate cooling circuit SKK
	A1/HC1	M2/HC2		
Mixer	—	X	X	—
① With heating water buffer cylinder (" Enable buffer cylinder/low loss header 7200 " set to "1"): <ul style="list-style-type: none"> Max. 3 heating circuits, of which max. 1 heating/cooling circuit or 1 separate cooling circuit 	X	X	X	X
② With a heating water/coolant buffer cylinder (" Enable buffer cylinder/low loss header 7200 " set to "2") ☒/☒: <ul style="list-style-type: none"> Max. 3 heating/cooling circuits 	X	X	X	—
③ With installation kit with mixer (" Type of assembly kit 7044 " set to "1"; Vitocal 111-S/222-A/222-S only): <ul style="list-style-type: none"> 2 heating circuits, of which max. 1 heating/cooling circuit 	X	X	—	—
Parameter	2xxx	3xxx	4xxx	71xx

Note

If the installation kit with mixer is installed and activated, please note the following:



- Heating circuit A1/HC1 must be connected, otherwise heating circuit M2/HC2 cannot be supplied with heat.
- Set the rated output of the heating circuit pump "**Rated output heating circuit pump HC2 734A**" in accordance with the required flow rate in heating circuit M2/HC2.
- It is not possible to operate a buffer cylinder in the secondary circuit flow.
- A sufficient system volume must be available in order to provide the defrost energy. For this, either install an overflow valve at the furthest point in the heating circuit or a heating water buffer cylinder with a low volume in the secondary circuit return.

Heating/cooling circuit system components

Heating/cooling circuit	Controlled directly		Controlled via KM-BUS M3/HC3	Separate cooling circuit SKK
	A1/HC1	M2/HC2		
Mixer	—	X	X	—
Mixer extension kit (KM-BUS)	—	—	X	—
Mixer motor				
<ul style="list-style-type: none"> Connection to heat pump control unit, direct control with 230 V~ signal 	—	X	—	—
<ul style="list-style-type: none"> Connection to mixer extension kit 	—	—	X	—
Heating circuit flow temperature sensor				
<ul style="list-style-type: none"> Connection to heat pump control unit (F12) 	—	X	—	—
<ul style="list-style-type: none"> Connection to mixer extension kit 	—	—	X	—

Function description

Heating circuits/cooling circuits (cont.)

Heating/cooling circuit	Controlled directly		Controlled via KM-BUS	Separate cool- ing circuit SKK
	A1/HC1	M2/HC2	M3/HC3	
Mixer	—	X	X	—
Room temperature sensor in Vitotrol 200-A/ 200-RF	○	○	○	—
Room temperature sensor cooling or room temperature sensor in Vitotrol 200-A/200-RF	—	—	—	X
Heating circuit pump				
▪ Connection to heat pump control unit	○ (212.2)	X (225.1)	—	—
▪ Connection to mixer extension kit	—	—	X	—
Heating water buffer cylinder	○	X ^{*1}	X	—
Heating water/coolant buffer cylinder 	○	X ^{*1}	X	—
System flow temperature sensor (F13)	○	○	○	—
NC mixer, part of NC-Box (accessories) 	X	○	○	○
Flow temperature sensor, cooling circuit (F14)	X ^{*2}	—	—	X
Contact humidistat for cooling mode	X	X	X	X

- X Present/required
 ○ Not required, but possible
 — Not possible

Note

The control characteristics of the heating circuit with mixer with directly controlled mixer motor can be adjusted with **"Runtime mixer heating circ 2015"**.

As the heating or cooling demand, the heat pump receives the maximum/minimum value of the demand from **all** heating/cooling circuits.

The flow temperature of the heating circuit without mixer may consequently rise higher than necessary for central heating. For central cooling in conjunction with a heating water/coolant buffer cylinder, the flow temperature for this heating/cooling circuit may be lower than necessary.

Weather-compensated control

The heat pump control unit determines the set flow temperature from the current set room temperature ("**Standard room temperature 2000**" or "**Reduced room temperature 2001**"), and the adjusted outside temperature according to the set heating/cooling curve.

Level and slope of these curves can be adjusted with the following parameters:

Curve	Level	Slope
Heating curve		
▪ All system configurations	"Heating curve level 2006, 3006, 4006"	"Heating curve slope 2007, 3007, 4007"
Cooling curve		
▪ Without buffer cylinder	"Cooling curve level 7110"	"Cooling curve slope 7111"
▪ With heating water buffer cylinder		
▪ With heating water/coolant buffer cylinder	"Cooling curve level 2040, 3040, 4040"	"Cooling curve slope 2041, 3041, 4041"

^{*1} Not possible in conjunction with the installation kit with mixer ("**Type of assembly kit 7044**" to "**1**")

^{*2} If no buffer cylinder is installed, the secondary circuit flow temperature sensor can also be used ("**Enable flow temperature sensor cooling circuit 7109**" set to "**0**").

Heating circuits/cooling circuits (cont.)

Room temperature hook-up

A room temperature sensor is required. The room temperature sensor integrated into the remote control is activated by parameter **"Remote control 2003"**. Room temperature hook-up is enabled via **"Room temperature hook-up 200B"**.

The following parameters are used to set the level of influence on the set flow temperature.

- Central heating via heating/cooling circuit: **"Influence room temperature hook-up 200A"**
- Central cooling via heating/cooling circuit, connected to heating water/coolant buffer cylinder: **"Influence room temperature hook-up cooling circuit 2034"**
- Central cooling via heating/cooling circuit without buffer cylinder/with heating water buffer cylinder or via separate cooling circuit: **"Influence room temperature hook-up cooling circuit 7104"**

Room temperature-dependent control

The heat pump control unit determines the set flow temperature from the difference between the set room temperature (**"Standard room temperature 2000"** or **"Reduced room temperature 2001"**) and the actual room temperature. Room temperature-dependent control can be switched on with **"Room temperature control 2005"**.

1 room temperature sensor is required. The room temperature sensor integrated into the remote control is activated by parameter **"Remote control 2003"**.

Heating limit and cooling limit

The heat pump operates either in heating mode or cooling mode. Simultaneous central heating and central cooling via different heating/cooling circuits is not possible.

Central heating is only enabled if the adjusted outside temperature (**"Interval for long term average outside temperature 7002"**) drops below the cooling limit. For central cooling, the adjusted outside temperature must exceed the cooling limit.

Cooling limit

The cooling limit results from the set room temperature plus **"Temperature differential for calculating the cooling limit 7004"**.

Heating limit

The heating limit results from the set room temperature less **"Temperature differential for calculating the heating limit 7003"**.

Changeover between central heating and central cooling

Depending on the system configuration, the heat pump control unit switches either manually or automatically between central heating and central cooling.

Manual switching

Only for system with heating water/coolant buffer cylinder and max. 3 heating/cooling circuits (system configuration ② on page 49)

To switch between central heating and central cooling, the mode of the heating water/coolant buffer cylinder **must** be switched manually (**"Buffer cyl operating mode 721F"**).

Automatic switching

Only with **one** of the following system configurations:

- 1 heating/cooling circuit without mixer, without buffer cylinder
- 1 separate cooling circuit
- System with heating water buffer cylinder and max. 3 heating circuits (system configuration ① on page 49)
- Heat pump with installation kit with mixer and system with max. 2 heating circuits (system configuration ③ on page 49)

Heating circuits/cooling circuits (cont.)

The heat pump control unit switches automatically between central heating and central cooling, subject to the adjusted outside temperature ("**Interval for long term average outside temperature 7002**"). Fixed hystereses are programmed to prevent brief fluctuations around these temperature limits from causing constant changeover between central heating and central cooling.

Note

- For frost protection, it is safer to also take account of short term fluctuations. Therefore, to start and stop the frost protection function, the heat pump control unit uses the **short term average** outside temperature.
- If a room temperature sensor is installed, a short term average is also available for the room temperature. The heat pump control unit uses this value for room temperature hook-up with weather-compensated control or for room temperature-dependent control ("**Room temperature control 2005**").

Starting central heating

If **all** of the following conditions are met, central heating starts:

- The adjusted outside temperature drops below the heating limit: See page 51.
- The "**Heating and DHW**" or "**Heating/cooling and DHW**" operating program is switched on.
- A time phase is active in "**Time program heating**" or "**Time progthg/cooling**" for the respective heating/cooling circuit.
- System with heating water buffer cylinder: A time phase is active in "**Time prog buffer cyl**".
- ☒ / ☒: System with heating water/coolant buffer cylinder (system configuration ② on page 49): A time phase is active in "**Time prog buffer cyl**". "**Buffer cyl operating mode 721F**" is set to "**0**".

Additional condition for **weather-compensated** control:

- The flow temperature is below the set flow temperature: See page 50.

Additional condition for **room temperature-dependent** control:

- The room temperature drops below the set room temperature: See page 51.

Note

If central heating is activated, the heating circuit pump runs constantly. For heating/cooling circuits without mixer which are connected directly to the heat pump, the secondary pump is on constantly.



"Vitotronic 200" operating instructions

Switching off central heating

In the case of **weather-compensated** control, central heating is switched off under the following conditions:

- One of the conditions for starting central heating is no longer met: See chapter on "Starting central heating".
- or
- The adjusted outside temperature exceeds the heating limit by 2 K.

For **room temperature-dependent** control or weather-compensated control with **room temperature hook-up**, central heating is switched off under the following conditions:

- One of the conditions for starting central heating is no longer met: See chapter on "Starting central heating".
- or
- The room temperature exceeds the set room temperature by 5 K.

Starting central cooling

If **all** of the following conditions are met, central cooling starts:

- The adjusted outside temperature exceeds the cooling limit: See page 51.
- The "**Heating/cooling and DHW**" operating program is activated.
- A time phase with the operating status "**Standard**" or "**Fixd value**" is active in "**Time progthg/cooling**" for the relevant heating/cooling circuit.

- ☒ / ☒: "**Enable active cooling 71FE**" is set to "**1**".
- ☒ / ☒: System with heating water/coolant buffer cylinder (system configuration ② on page 49): A time phase is active in "**Time prog buffer cyl**". "**Buffer cyl operating mode 721F**" is set to "**1**".



"Vitotronic 200" operating instructions

Heating circuits/cooling circuits (cont.)

Additional condition for **weather-compensated** control:

- The flow temperature is above the set flow temperature: See page 50.

Additional condition for **room temperature-dependent** control:

- The room temperature exceeds the set room temperature: See page 51.

Note

If central cooling is activated, the heating circuit pump runs constantly. For heating/cooling circuits without mixer which are connected directly to the heat pump, the secondary pump is on constantly.

Deactivating central cooling

In the case of **weather-compensated** control, central cooling is switched off under the following conditions:

- One of the conditions for starting central cooling is no longer met: See chapter on "Starting central cooling".
- or
- The adjusted outside temperature drops below the cooling limit by 1 K.

For **room temperature-dependent** control or weather-compensated control with **room temperature hook-up**, central cooling is switched off under the following conditions:

- One of the conditions for starting central cooling is no longer met: See chapter on "Starting central cooling".
- or
- ☒ / ☒: System with heating water/coolant buffer cylinder (system configuration ② on page 49): The room temperature falls below the set room temperature by 2 x "**Hysteresis room temp cooling circuit 2037**".

System without buffer cylinder or with heating water buffer cylinder (system configuration ① on page 49): The room temperature falls below the set room temperature by 2 x "**Hysteresis room temp cooling circuit 7107**".

Operating status for central heating/cooling

Operating status	Description
"Standard"	The set room temperature for central heating/central cooling is the " Standard room temperature 2000 ".
"Reduced"	The set room temperature for central heating/central cooling is the " Reduced room temperature 2001 ". Note Central cooling is not possible in this operating status.
"Fixed value"	<ul style="list-style-type: none"> ▪ Central heating with "Max. flow temperature heating circuit 200E" ▪ Central cooling without buffer cylinder or with heating water buffer cylinder bypass: Central cooling with "Min. flow temperature cooling 7103" ▪ Central cooling with heating water/coolant buffer cylinder: Central cooling with "Min. set flow temperature, cooling 2033"
"Standby"	This operating status is active if no other operating status has been selected. Frost protection is active: See following chapter. Note Central cooling is not possible in this operating status.

Heating circuits/cooling circuits (cont.)

Frost protection

The frost protection function for one heating/cooling circuit is only active when central heating is switched off by the **"Only DHW"** or **"Standby mode"** operating program, or when operating status **"Standby"** is set in the time program. The **"Standby"** operating status is set if **no** time phase is active in the time program.

Central heating is active if **one** of the following conditions is met:

- Short term average outside temperature falls below the frost protection limit. This frost protection limit is factory-set.
- Room temperature falls below 5 °C (parameter **"Remote control 2003"** set to **"1"**).
- System flow temperature falls below 5 °C.

In the case of frost protection, the heating circuit pumps and the secondary pump are started alongside the heat pump.

Heating for frost protection ends if **all** of the following criteria are met:

- Short term average outside temperature exceeds the frost protection limit by at least 2 K.
- Room temperature exceeds 7 °C (parameter **"Remote control 2003"** set to **"1"**).
- System flow temperature exceeds 15 °C.

Note

The frost protection limit is factory-set to 1 °C. This setting can only be changed by a heating contractor certified by Viessmann.

In order to prevent pumps switched by the heat pump control unit from seizing up, these pumps start daily from 13:00 h in sequence for 10 s (pump kick). The circulation pump for cylinder heating or the 3-way diverter valve "Heating/DHW" start daily at 0:00 h for 30 s.

Central heating with booster heaters

See also chapter "Booster heaters" on page 37.

If the following criteria are all met **simultaneously**, the heat pump control unit will send a demand to either the external heat generator or the instantaneous heating water heater while the central heating is on:

- Heating circuit flow temperature remains below the set flow temperature for more than 4 h.
- With activated room temperature hook-up, the room temperature is more than 0.5 K below the set room temperature.
- Booster heaters are enabled for central heating. The respective start criteria are met:
 - External heat generator: See page 38.
 - Instantaneous heating water heater: See page 40.

Note

***"Priority ext. heat source/instant. heating water heater 7B01"** specifies which booster heater is switched on first for central heating. Both booster heaters are switched on simultaneously for frost protection of the heating circuits.*

Central heating with ventilation unit (supply air heating)

See page 63.

Cooling via a separate cooling circuit

Note

On systems with heating water/coolant buffer cylinder, central cooling via a separate cooling circuit is not possible.

- Only possible if no cooling takes place via a heating circuit (parameter **"Cooling circuit 7101"**).
- There must **always** be 1 room temperature sensor installed:
 - Remote control room temperature sensor (**"Remote control cooling circ 7116"**)
 - or
 - Room temperature sensor connected separately to the control unit (**"Ranking room temp sensor separate cooling circuit 7106"**).

Heating circuits/cooling circuits (cont.)

- A separate cooling circuit is constantly cooled, irrespective of the cooling limit.
- **No time program** can be set for a separate cooling circuit.

Note

The separate cooling circuit can be switched over to weather-compensated cooling mode. For this, set **"Room temperature control cooling circuit 7105"** to **"0"**.

With this setting, continuous cooling with a constant temperature level is not assured. We therefore recommend that you always cool the separate cooling circuit in room temperature-dependent mode.

Natural cooling function (NC) 

The NC-Box **with mixer** (accessories) is required for the natural cooling function.

The temperature level of the ground is transferred directly to the cooling circuit. This function is energy saving, since the compressor is switched off.

Note

- The natural cooling function is not possible in conjunction with a heating water/coolant buffer cylinder.
- The mixer in the NC-Box will hold the flow temperature above the dew point temperature, particularly when providing cooling by means of underfloor heating circuits.

The cooling function is controlled via connection 211.5 on the main PCB: See page 280.

Required parameter settings without buffer cylinder

- **"Cooling function 7100"** set to **"2"**
- Selecting the cooling circuit: **"Cooling circuit 7101"**

Active cooling function (AC)   / 

In cooling mode the heat pump operates in reverse (refrigerant circuit reversal).

The compressor is in operation. The cooling capacity is adjusted by modulating the heat pump.

System without buffer cylinder

The coolant goes directly into the heating/cooling circuit or into the separate cooling circuit.

Required parameter settings

- **"System scheme 7000"** set to **"1"** or **"2"**
- **"Enable buffer cylinder/low loss header 7200"** set to **"0"**

- **"Cooling function 7100"** set to **"3"**
- **"Cooling circuit 7101"** set to **"1"**

System with heating water buffer cylinder

If the system is equipped with a heating water buffer cylinder, the heating water buffer cylinder must be bypassed in cooling mode by means of a hydraulic bypass circuit. For this, two 3-way diverter valves are integrated into the system return. These 3-way diverter valves are controlled via connection 211.5 on the main PCB: See page 281.

To ensure the minimum system volume for central cooling, an additional low-volume heating water buffer cylinder, e.g. Vitocell 100-E, may need to be integrated into this bypass circuit.

Note

Only 1 cooling circuit is possible.

Required parameter settings

- **"Enable buffer cylinder/low loss header 7200"** set to **"1"**
- **"Cooling function 7100"** set to **"3"**
- Selecting the cooling circuit: **"Cooling circuit 7101"**

Active cooling function (AC) ☒ / ☒ (cont.)

System with heating water/coolant buffer cylinder

The coolant is fed into the heating water/coolant buffer cylinder which supplies a maximum of 3 heating/cooling circuits.

- "Cooling function 7100" set to "3"
- "Cooling 2030" and/or "Cooling 3030" and/or "Cooling 4030" set to "2"

Required parameter settings

- "Enable buffer cylinder/low loss header 7200" set to "2"
- "Buffer cyl operating mode 721F" set to "1"

Swimming pool heating

The heat pump control unit supports heating of a swimming pool.

- For swimming pool heating, the heat pump demand is issued externally by the temperature controller for regulating the swimming pool temperature.
- Swimming pool heating is controlled via the EA1 extension with KM-BUS.
- In the delivered condition, swimming pool heating has the lowest priority compared to central heating/central cooling and DHW heating. Priority of swimming pool heating over central heating/central cooling can be changed with "Priority external demand 7019".
- The set flow temperature for swimming pool heating is specified as follows:
 - "Flow temperature for external demand 730C" or
 - Analogue voltage signal at "0 - 10 V" input of EA1 extension
 The higher value is used.

- In heat pump cascades consisting of heat pumps with output-dependent control (☒ / ☒), a swimming pool flow temperature sensor is additionally required (connection F21 on the controller and sensor PCB). Based on this flow temperature, the heat pumps can be operated in the optimum output range.
- A filter circuit pump **cannot** be controlled via the heat pump control unit.

Enabling required

Parameter	Setting
"External extension 7010"	"1" or "3"
"Swimming pool 7008"	"1"

Switching swimming pool heating on and off

When the temperature controller for regulating swimming pool temperature issues a heat demand, the heat pump switches on.

In heat pump cascades, the lead and/or lag heat pumps can be switched on, depending on the heat demand.

Note

The instantaneous heating water heater and the external heat generator **cannot** be used for swimming pool heating.

During swimming pool heating, the compressor and the secondary pump are operational. At the same time, the "Swimming pool heating" 3-way diverter valve is switched to position "Swimming pool" and the circulation pump for swimming pool heating is started. The buffer cylinder is then no longer heated up.

Swimming pool heating ends as soon as the heat demand from the temperature controller for regulating the swimming pool temperature ceases.

System examples with swimming pool heating:
www.viessmann-schemes.com

Swimming pool heating (cont.)

Connections at EA1 extension

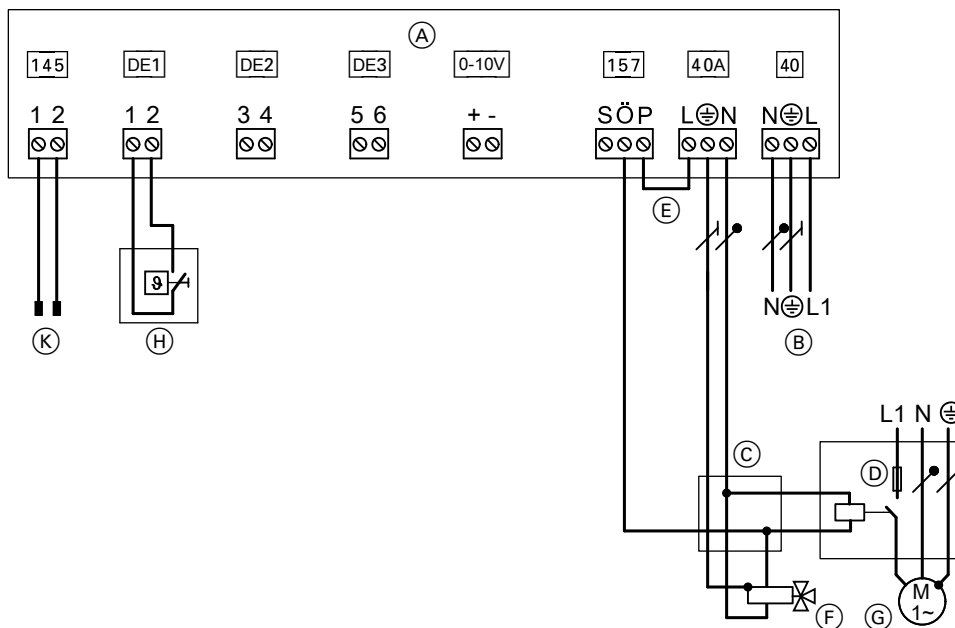

Fig. 11

- (A) EA1 extension
- (B) Power supply 1/N/PE 230 V/50 Hz
- (C) Junction box (on site)
- (D) Fuses and contactor for circulation pump for swimming pool heating (accessories)
- (E) Jumper
- (F) 3-way diverter valve "Swimming pool" (zero volt: Buffer cylinder heating)
- (G) Circulation pump for swimming pool heating (accessories)
- (H) Temperature controller for regulating the swimming pool temperature (floating contact: 230 V~, 0.1 A, accessories)
- (K) Connection to controller and sensor PCB

Mechanical ventilation

For mechanical ventilation, a Viessmann ventilation unit is connected to the heat pump control unit via Modbus. This enables full operation of the mechanical ventilation system and setting of the control parameters via the heat pump control unit. Changed parameters are transferred to the ventilation controller integrated in the ventilation unit. Commissioning (e.g. function check) and diagnosis (e.g. system overview, scanning messages) can also be undertaken at the heat pump control unit.

Release

	Vitovent				
	200-C	200-W	300-C	300-F	300-W
"Vitovent enable 7D00"	"2"	"3"	"3"	"1"	"3"

Parameter

	Vitovent				
	200-C	200-W	300-C	300-F	300-W
▪ "7Dxx"	X	X	X	X	X
▪ "C1xx"	—	X	X	—	X

Function description

Mechanical ventilation (cont.)

Functions







	Vitovent				
	200-C	200-W	300-C	300-F	300-W
▪ Controlled mechanical ventilation with heat recovery	X	X	X	X	X
▪ Passive cooling	X	X	X	X	X
▪ Passive heating	X	—	—	X	—
▪ Supply air heating in conjunction with an integral hydraulic reheating coil (ventilation heating circuit)	—	—	—	X	—
▪ Humidity and CO ₂ concentration control	—	X	X	X	X

Mechanical ventilation with Vitovent 200-C/300-F

Controlled mechanical ventilation

The ventilation unit controls the fan speed so that a consistent air flow rate is achieved for each ventilation level. This means that the pressure drop of the ductwork and filters does not affect the air flow rate.

Ventilation levels

Ventilation level	Function/operating program	Operating status in the "Time prog ventilation"	Vitovent air flow rate	
			200-C	300-F
	Communication interrupted		50 m ³ /h	85 m ³ /h
	Ventilation unit switched off		0 m ³ /h	0 m ³ /h
	"Standby mode"			
	"Economy mode"	—	50 m ³ /h	85 m ³ /h
	"Standard operation"			
	"Holiday program"			
	"Ventilation program"	"Reduced"	"Flow rate reduced ventilation 7D0A"	
			Factory setting:	75 m ³ /h
		"Standard"	"Flow rate nominal ventilation 7D0B"	
			Factory setting:	115 m ³ /h
	"Intensive operation"	"Intensive"	"Flow rate intensive ventilation 7D0C"	
			Factory setting:	155 m ³ /h

Note

"Standard operation" is active automatically between the time phases in the time program.



"Vitotronic 200" operating instructions

- **"Intensive operation"** is limited to **"Intensive ventilation duration 7D1B"**.
- Vitovent 200-C: If **"Intensive operation"** was activated via a switch or button (bathroom switch), the duration is limited to **"Duration, bathroom vent. 7D3B"**.

Mechanical ventilation with Vitovent 200-C/300-F (cont.)

Vitovent 300-F: In the **"Standard"** operating status, the air flow rate can automatically be adjusted subject to the following factors:

- Humidity:
Measurement via CO₂/humidity sensor (accessories)
- CO₂ concentration:
Measurement via CO₂/humidity sensor (accessories)

Vitovent 200-C: External starting of Intensive operation

"Intensive operation" can be started with an external switch or button (bathroom switch). This bathroom switch is connected to the ventilation unit. To activate the bathroom switch function, set **"Function, external 230 V input, ventilation"** to **"1"**.

When the bathroom switch has been held down for 2 to 5 s, **"Intensive operation"** is switched on for **"Duration, bathroom vent. 7D3B"**.

Otherwise **"Intensive operation"** remains active for as long as the bathroom switch is held down, up to a max. of **"Duration, bathroom vent. 7D3B"**.

Note

"Intensive operation" can be terminated at any time at the heat pump control unit, using **"Standby mode"**.

Heat recovery and humidity control

In standard ventilation mode the outdoor air and extract air flow through the heat exchanger. All heat exchangers used operate according to the countercurrent principle. This principle allows much of the thermal energy of the extract air to be transferred to the cool outdoor air, without the two air flows mixing together. If an enthalpy heat exchanger is installed in the ventilation unit, a part of the humidity is also transferred to the supply air stream in addition to the thermal energy. This contributes to a healthy ambience.

The type of heat exchanger is set as follows:

Heat exchanger	"Type of heat exchanger 7D2E"
Countercurrent heat exchanger	"0"
Enthalpy heat exchanger	"1"

During heat recovery and humidity control the bypass is **not** active.

Passive heating

With passive heating, the ventilation unit uses the outdoor air for central heating.

For this, the outdoor air is **not** routed via the heat exchanger, but instead via the bypass directly into the rooms.

The bypass is active in the following cases:

- Passive cooling is switched on: See chapter "Passive cooling".
- Passive heating is switched on: See chapter "Passive heating".
- Vitovent 200-C: The heat exchanger is defrosted with a function that allows the cool outdoor air to be routed past the heat exchanger by means of the bypass: See chapter "Vitovent 200-C: Frost protection".

Balancing of the supply air and extract air flow rates

Due to the conditions in the building, an unwanted flow rate differential (disbalance) may occur between the supply air and extract air side, e.g. through different lengths of pipework for outdoor/supply air and extract/exhaust air.

Note

To determine the flow rate differential, the captured flow rates of all supply air apertures must be added together and compared to the total flow rates of all extract air apertures.



Ventilation unit installation and service instructions

Flow rate differentials > 10 % must be balanced out as follows:

Vitovent 200-C:

- To balance out the flow rate differentials, the control voltages of the supply **and/or** exhaust air fan can be permanently increased or reduced (**"Control voltage matching, supply air fan 7D71"** and **"Control voltage matching, exhaust air fan 7D72"**).

Vitovent 300-F:

- **"Control voltage matching 7D27"** permanently raises the air flow rate of one fan compared to the other. **"Fan for control voltage matching 7D28"** determines whether the air flow rate should be raised for the supply air **or** the exhaust air fan.

Note

To avoid imbalances, the control voltage of the fan that has not been selected is simultaneously limited to 10 V minus **"Control voltage matching 7D27"**. This also reduces the maximum air flow rate.

Note

- Subject to the temperature conditions, only low heating outputs are available.
- Vitovent 300-F: Ventilation level  is set while the bypass opens or closes.

Mechanical ventilation with Vitovent 200-C/300-F (cont.)

Conditions for passive heating

Passive heating ON	Passive heating OFF
<p>All of the following conditions must be met:</p> <ul style="list-style-type: none"> Outdoor air temperature (heat exchanger air intake) \geq extract air temperature plus 4 K Extract air temperature \leq "Set room temperature 7D08" minus 1 K 	<p>One of the following conditions must be met:</p> <ul style="list-style-type: none"> Outdoor air temperature (heat exchanger air intake) \leq extract air temperature plus 3 K Extract air temperature \geq "Set room temperature 7D08"

Passive heating will not start if **one** of the following conditions applies (bypass not active):

- A sensor or fan fault has occurred.
- Frost protection is active.
- If room cooling is switched on: Room cooling is carried out via a heating/cooling circuit that also supplies the ventilated rooms ("**Heating circuit for blocking bypass damper 7D21**"). This prevents the heat drawn off via the heating/cooling circuit being reintroduced from the outside by the ventilation unit bypass.

- Vitovent 200-C: The electric preheating coil has been on in the last 10 min.
- Vitovent 300-F: **"Set room temperature 7D08"** is set min. 4 K lower than **"Standard room temperature 2000"**.

Passive cooling

With passive cooling, the ventilation unit uses the outdoor air for central cooling.

With passive cooling, the outdoor air is **not** routed via the heat exchanger, but instead via the bypass directly into the rooms. The bypass opens and closes automatically, depending on the following conditions:

Note

Subject to the temperature conditions, only low cooling capacities are available during passive cooling.

Vitovent 200-C: Conditions for passive cooling

Passive cooling ON	Passive cooling OFF
<p>All of the following conditions must be met:</p> <ul style="list-style-type: none"> Outdoor air temperature (heat exchanger air intake) $<$ extract air temperature minus 4 K Outdoor air temperature (heat exchanger air intake) $>$ "Min. supply air temperature for bypass 7D0F" plus 0.5 K Extract air temperature $>$ "Set room temperature 7D08" plus 1 K 	<p>One of the following conditions must be met:</p> <ul style="list-style-type: none"> Outdoor air temperature (heat exchanger air intake) \geq extract air temperature minus 3 K Outdoor air temperature (heat exchanger air intake) \leq "Min. supply air temperature for bypass 7D0F" plus 0.5 K Extract air temperature \leq "Set room temperature 7D08"

Passive cooling will not start if **one** of the following conditions is met (bypass not active):

- A sensor or fan fault has occurred.
- Frost protection is active.
- If central heating is switched on: Central heating via one heating circuit that also supplies the ventilated rooms ("**Heating circuit for blocking bypass damper 7D21**"). This prevents heat supplied via the heating circuits being routed outside via the bypass.
- The electric preheating coil has been on in the last 10 min.

Mechanical ventilation with Vitovent 200-C/300-F (cont.)**Vitovent 300-F: Conditions for passive cooling****Note**

Ventilation level  is set while the bypass opens or closes.

Passive cooling ON	Passive cooling OFF
<p>All of the following conditions must be met:</p> <ul style="list-style-type: none"> ▪ Outdoor air temperature (heat exchanger air intake) < extract air temperature minus 4 K ▪ Supply air temperature > "Min. supply air temperature for bypass 7D0F" minus 1.5 K ▪ Outdoor air temperature (heat exchanger air intake) > "Min. supply air temperature for bypass 7D0F" plus 1.5 K ▪ Extract air temperature > "Set room temperature 7D08" plus 1 K 	<p>One of the following conditions must be met:</p> <ul style="list-style-type: none"> ▪ Outdoor air temperature (heat exchanger air intake) ≥ extract air temperature minus 3 K ▪ Supply air temperature ≤ "Min. supply air temperature for bypass 7D0F" minus 1.5 K ▪ Outdoor air temperature (heat exchanger air intake) ≤ "Min. supply air temperature for bypass 7D0F" plus 1.5 K ▪ Extract air temperature ≤ "Set room temperature 7D08"

Passive cooling will not start if **one** of the following conditions is met (bypass not active):

- A sensor or fan fault has occurred.
- Frost protection is active.
- If central heating is switched on:
 - Central heating via one heating circuit that also supplies the ventilated rooms ("**Heating circuit for blocking bypass damper 7D21**").
 - This prevents heat supplied via the heating circuits being routed outside via the bypass.
- "**Set room temperature 7D08**" is set min. 4 K higher than "**Standard room temperature 2000**".

Vitovent 200-C: Frost protection**Defrost functions**

The degree of icing up of the heat exchanger is monitored. The selected defrost function is activated according to the degree of ice formation: See following table.

To determine the degree of ice formation the **two** following variables are observed and additional conditions are taken into account, e.g. the installation position of the ventilation unit ("**Installation position 7D2F**").

- **Fan speeds:**
 - The pressure differential in the heat exchanger rises with increasing ice formation. The fan speeds are automatically increased to maintain a constant air flow rate. From a certain speed onwards it is assumed that the heat exchanger is iced up.
- **Supply air temperature:**
 - The heat exchanger transfers less heat from the extract air to the outdoor air due to ice formation. The supply air temperature drops. From a certain supply air temperature threshold onwards it is assumed that the heat exchanger is iced up.

Monitoring of ice formation is active under the following conditions:

- The outdoor air temperature is below 2 °C.
- No defrost function was active during the last 15 min.
- The fans are switched on.
- None of the temperature sensors in the ventilation unit is faulty.

The defrost function is selected with the parameters "**Enable preheater bank electric 7D01**" and "**Strategy, passive frost protection 7D2C**".

Mechanical ventilation with Vitovent 200-C/300-F (cont.)**Without electric preheating coil**

Defrost function	Description	Setting	
		"7D01"	"7D2C"
Shutdown of fans	If the heat exchanger is iced-up, both fans are switched off.	"0"	"0"
Defrosting via bypass	If the heat exchanger is iced-up, the bypass opens and the cool outdoor air is routed past the heat exchanger. The extract air additionally heats the heat exchanger. This causes the ice to melt and drain off as condensate. Note <i>Condensate may form in the cooling supply air pipes.</i> In the case of persistent ice formation both fans are switched off.	"0"	"1"
Defrosting by means of disbalance	If the heat exchanger is iced-up, the supply air fan is switched off. The extract air heats the heat exchanger. This causes the ice to melt and drain off as condensate. In the case of persistent ice formation both fans are switched off.	"0"	"2"

With electric preheating coil

Defrost function	Description	Setting	
		"7D01"	"7D2C"
Defrosting via bypass	If the heat exchanger is iced-up the electric preheating coil is switched on and the bypass is activated. The ice melts and drains off as condensate. If the output of the preheating coil is not enough, the supply air flow rate is additionally reduced in stages.	"1"	—

Frost protection comfort function

With the frost protection comfort function, ice formation on the heat exchanger is largely prevented. If "**Enable preheater bank electric 7D01**" is set to "**2**", this function is **always** active.

The electric preheating coil is switched on if the differential between supply air and extract air temperature exceeds 4.5 K. This protects the heat exchanger of the ventilation unit against icing up.

If the output of the electric preheating coil is no longer adequate due to low outside temperatures, the supply air flow rate is incrementally reduced.

With frost protection comfort function the bypass is not active. Heat recovery remains switched on.

The frost protection comfort function prevents uncomfortable supply air temperatures, however, the energy demand during extreme weather conditions is slightly higher than when defrosting via bypass.

Starting the fans up again

If the temperature conditions during an active defrost or frost protection function cause the fans to be shut down, the fans can not start back up until the next start time is reached.

Requirement: The temperature conditions for start up are met.

The start times are set with "**Starting block, ventilation periods part 1 7D5E**" and "**Starting block, ventilation periods part 2 7D5F**".

Mechanical ventilation with Vitovent 200-C/300-F (cont.)

Vitovent 300-F: Frost protection

Frost protection without preheating coil

As soon as the outdoor air temperature falls below 0 °C, the supply air fan switches off. The exhaust air fan continues to run, causing the warm extract air to flow through the heat exchanger, thereby preventing ice formation on the exhaust air side. Ventilation level $\leftarrow \uparrow$ is set for the exhaust air flow rate.

This frost protection function remains switched on for 2 h. If after these 2 h the outdoor air temperature exceeds 0 °C, ventilation level $\leftarrow \uparrow$ is initially switched on for 10 min. If the outdoor air temperature continuously remains above 0 °C during these 10 min, the previously active ventilation function starts up again. Otherwise the frost protection function is switched on for a further 2 h.

Note

In very airtight buildings, the frost protection function can sometimes result in the exhaust air flow rate having to be maintained at a constant via increased exhaust air fan speed. If during this process the max. speed is reached for 3 min, the exhaust air fan also switches off.

Frost protection with electric preheating coil

To avoid the frequent reduction of the supply air flow rate or the switching off of the fans due to low outdoor air temperatures, an electric preheating coil (accessories) can be installed. This preheating coil is electrically connected to the controller PCB of the ventilation unit. The preheating coil starts if the exhaust air temperature falls below the set value. The heating output is controlled subject to either the exhaust air **or** the outdoor air temperature, depending on which temperature is furthest below the relevant set value.

Set values:

- Exhaust air temperature: 3.5 °C
- Outdoor air temperature: 2 °C

If the preheating coil operates for 10 min with a heating output of 100 %, the ventilation level is also reduced under the following conditions, if required until the fans are switched off:

- Exhaust air temperature < 4.5 °C
- or**
- Outdoor air temperature < 3 °C

Note

If the ventilation level has been reduced for frost protection, control of the CO₂ concentration and humidity will not be active: See page 64.

If the electrical output of the preheating coil falls below 85 % for 10 min, the ventilation level is gradually increased until the specified stage has been reached.

Enable required

Parameter	Setting
"Enable preheater bank electric 7D01"	"1"

Note

The electric preheating coil cannot be used for central heating (supply air heating).

Vitovent 300-F: Supply air heating

With the installation of the hydraulic reheating coil (accessories), Vitovent 300-F can be used for supply air heating.

The reheating coil of the Vitovent 300-F is connected hydraulically as heating circuit A1/HC1 (ventilation heating circuit). If there is **no** buffer cylinder in the heating system, the heating water buffer cylinder available as an accessory (25 l) must be installed in the Vitovent 300-F. This heating water buffer cylinder supplies the Vitovent 300-F with heat and makes the necessary defrosting energy available to the heat pump.

Note

If only the ventilation heating circuit A1/HC1 is connected to the heat pump (e.g. in a passive house), observe the following:

- *The heating output of the heat pump must correspond to the max. output of the reheating coil. Otherwise use a buffer cylinder with a large volume.*
- *Supply air heating can only be used as the sole heat source in buildings with a high insulation standard, e.g. in passive houses.*
- *No supply air heating occurs in "Standby mode".*

Mechanical ventilation with Vitovent 200-C/300-F (cont.)

A buffer cylinder with a large volume should be integrated in the heating system if the following conditions apply. In this case the heating water buffer cylinder integrated in the Vitovent 300-F will not be required.

- There are other heating circuits in addition to the ventilation heating circuit A1/HC1.
- The heating output of the heat pump is greater than the max. output of the reheating coil.

The set flow temperature of the heating circuit in weather-compensated mode is derived from the set room temperature ("**Standard room temperature 2000**" / "**Reduced room temperature 2001**") and the adjusted outside temperature according to the set heating curve: See chapter "Heating/cooling circuits". As the flow temperature must be above the supply air temperature for heat transfer, the set flow temperature determined from the heating curve is increased by 5 K.

Note

- *Room temperature-dependent control ("**Room temperature control 2005**" set to "1") can not be selected in conjunction with supply air heating.*
- *To avoid stirring up dust and therefore creating an odour nuisance when providing supply air heating with Vitovent 300-F, the supply air temperature must not exceed 52 °C. For this, limit the set flow temperature of **all** heating circuits to max. 57 °C ("**Max. flow temperature heating circuit 200E, 300E**").*

Required settings

Parameter	Setting
"Enable reheater bank hydraulic 7D02"	"1"
"System scheme 7000"	"1", "2", "5", "6"
Parameters for additional system components	See relevant chapter.

Protection against excessively high temperatures

If the outdoor air temperature exceeds 50 °C (e.g. when there is a fault in the preheating coil), the fan speed increases. This dissipates excess heat. From 80 °C, the max. fan speed is set.

Vitovent 300-F: Humidity and/or CO₂ concentration control

A CO₂/humidity sensor (accessories) is required for regulating air humidity and/or CO₂ concentration. This sensor is mounted in a **single room**.

The air flow rate is adjusted subject to the air humidity and/or the CO₂ concentration **of this room**.

If the humidity in this room exceeds "**Humidity value for raising the flow rate 7D19**" and/or the CO₂ concentration "**CO₂ value for raising the flow rate 7D18**", the air flow rate is increased. The air flow rate is reduced when these values are undershot.

Note

The higher air flow rate is always selected if both functions are active (see table below).

- The control limits are the air flow rates of the "**Reduced**" and "**Intensive**" operating statuses.
- For these functions, the "**Standard**" operating status must be active in the time program.

Enabling required

Function	Parameter	Setting
Humidity control	"Enable humidity sensor 7D05"	"1"
CO ₂ concentration control	"Enable CO ₂ sensor 7D06"	"1"

Mechanical ventilation with Vitovent 200-W/300-C/300-W







Controlled mechanical ventilation

Control of the air flow rate

- Vitovent 200-W:
The ventilation unit regulates to a constant fan speed in each ventilation level. The actual air flow rate of the mechanical ventilation system is therefore dependent on the pressure drop resulting from the ductwork and the filters.
- Vitovent 300-C/300-W:
The ventilation unit controls the fan speed so that a consistent air flow rate is achieved for each ventilation level. This means that the pressure drop of the ductwork and filters does not affect the air flow rate.

The currently applicable ventilation level is either specified via the operating status in the time program, by the set operating program or by the selected function.

Ventilation levels

Ventilation level	Function/operating program	Operating status in the "Time prog ventilation"	Vitovent air flow rate		
			200-W	300-C	300-W
	Communication interrupted		Air flow rate of the most recently active ventilation level		
	Ventilation unit switched off		0 %	0 m ³ /h	0 m ³ /h
	"Standby mode"				
	"Economy mode"	—	"Background ventilation C109"		
	"Standard operation"		Factory setting:		
	"Holiday program"		15 %	30 m ³ /h	50 m ³ /h
	"Ventilation program"	"Reduced"	"Reduced ventilation C10A"		
			Factory setting:		
		"Standard"	"Standard ventilation C10B"		
			Factory setting:		
	"Intensive operation"	"Intensive"	"Intensive ventilation C10C"		
			Factory setting:		
			75 %	125 m ³ /h	225/300 m ³ /h

Note

"Standard operation" is active automatically between the time phases in the time program.



"Vitotronic 200" operating instructions

"Intensive operation" is limited to **"Intensive ventilation duration 7D1B"**.

In the operating status **"Standard"** and **"Reduced"** the air flow rate can automatically be adjusted subject to the following factors:

- Humidity:
Measurement via central humidity sensor (accessories)
- Humidity:
Measurement via CO₂/humidity sensor (accessories)
- CO₂ concentration:
Measurement via CO₂/humidity sensor (accessories)

Heat recovery and humidity control

In standard ventilation mode the outdoor air and extract air flow through the heat exchanger. All heat exchangers used operate according to the counter-current principle. This principle allows much of the thermal energy of the extract air to be transferred to the cool outdoor air, without the two air flows mixing together.

Mechanical ventilation with Vitovent... (cont.)

If an enthalpy heat exchanger is installed in the ventilation unit, a part of the humidity is also transferred to the supply air stream in addition to the thermal energy. This contributes to a healthy ambience.

During heat recovery and humidity control the bypass is **not** active.

For passive cooling the bypass is switched on: See chapter "Passive cooling".

Balancing of the supply air and extract air flow rates

Due to the conditions in the building, an unwanted flow rate differential (disbalance) may occur between the supply air and extract air side, e.g. through different lengths of pipework for outdoor/supply air and extract/exhaust air.

Note

To determine the flow rate differential, the captured flow rates of all supply air apertures must be added together and compared to the total flow rates of all extract air apertures.



Ventilation unit installation and service instructions

Flow rate differentials > 10 % must be balanced out as follows:

Vitovent 200-W:

- The air flow rates for supply air and extract air can be set separately for each ventilation level, e.g. **"Standard ventilation C10B"** for the supply air stream and **"Standard ventilation, second fan duct C18B"** for the extract air stream.

Vitovent 300-C/300-W:

- To enable the balancing of flow rate differences between the supply and extract air sides, **"Imbalance permitted C1A2"** must be set to **"1"**. The increasing or decreasing of the supply air stream in comparison to the extract air stream can be set with **"Specified imbalance C1A3"**.

Passive cooling

With passive cooling, the ventilation unit uses the outdoor air for central cooling.

Note

Subject to the temperature conditions, only low cooling capacities are available during passive cooling.

With passive cooling, the outdoor air is **not** routed via the heat exchanger, but instead via the bypass directly into the rooms. The bypass opens and closes automatically, depending on the following conditions:

Conditions for passive cooling

Enabling required

Parameter	Setting
"Bypass mode C1A0"	"0"

Passive cooling ON	Passive cooling OFF
<p>All of the following conditions must be met:</p> <ul style="list-style-type: none"> ▪ Outdoor air temperature (heat exchanger air inlet) > 7 °C ▪ Extract air temperature > "Set room temperature C108" plus 2 K ▪ Extract air temperature > outdoor air temperature 	<p>One of the following conditions must be met:</p> <ul style="list-style-type: none"> ▪ Outdoor air temperature (heat exchanger air intake) ≤ 6.5 °C ▪ Extract air temperature ≤ "Set room temperature C108" minus 0.5 K ▪ Extract air temperature ≤ outdoor air temperature minus 0.5 K

Passive cooling will not start if **one** of the following conditions is met (bypass not active):

- If central heating is switched on:
 - Central heating via one heating circuit that also supplies the ventilated rooms (**"Heating circuit for blocking bypass damper 7D21"**).
 - This prevents heat supplied via the heating circuits being routed outside via the bypass.
- **"Set room temperature C108"** is set min. 4 K higher than **"Standard room temperature 2000"**.

Mechanical ventilation with Vitovent... (cont.)**Cooling via geothermal heat exchanger**

The outdoor air can be routed through a geothermal heat exchanger (on site), regardless of the position of the bypass damper integrated into the ventilation unit. This causes the outdoor air to cool down in the ground during the warmer months.

If the outdoor air exceeds "**Max. temperature, geothermal heat exchanger C1AB**", the 3-way diverter damper (on site) opens up the path through the geothermal heat exchanger. Below this temperature the outdoor air flows directly into the ventilation unit uncooled.

Required enable, 3-way diverter damper (on site)

Parameter	Setting
"Preheating coil C101"	"65" or "81"

Frost protection with factory-fitted electric preheating coil

The ventilation units are factory-fitted with an electric preheating coil.

The factory-fitted electric preheating coil is switched on if the outside temperature falls below -1.5 °C for more than 5 min. With the Vitovent 300-W, the pressure in the exhaust air duct is also monitored as an additional activation condition.

The output of the factory-fitted electric preheating coil is controlled so that the following outside air temperatures are achieved:

- Vitovent 200-W: 0 °C
- Vitovent 300-C: 4 °C
- Vitovent 300-W: -1.5 °C

If the relevant outdoor air temperature is not reached with max. heating output, the air flow rate is additionally reduced to protect the heat exchanger.

- Pressure imbalance is permitted ("**Specified imbalance C1A3**" set to "**1**"): Only the supply air flow rate is reduced.
- Pressure imbalance is not permitted ("**Specified imbalance C1A3**" set to "**0**"): Supply air and extract air flow rate are reduced.

Requirement: **No** additional electric preheating coil is installed in the outdoor air duct: See the following chapter.

End of frost protection function

If outdoor air temperatures are above -1.5 °C the air flow rate is initially raised back up to the original value in increments. Subsequently the output of the electric preheating coil is reduced, and if no longer required the preheating coil is switched off.

Frost protection with additional electric preheating coil

The additional electric preheating coil (accessories) is installed in the outdoor air duct.

If the output of the factory-fitted preheating coil is not sufficient for reaching the relevant outdoor air temperature (-1.5 °C , 0 °C , 4 °C), the additional electric preheating coil is switched on. The air flow rate is only reduced if the heating output of **both** preheating coils combined is insufficient.

Enable required

Parameter	Setting
"Preheating coil C101"	"17" or "81"

End of frost protection function

See chapter "Frost protection with factory-fitted electric preheating coil".

Frost protection with geothermal heat exchanger

For preheating, the outdoor air can be routed through a geothermal heat exchanger (on site).

Function description

Mechanical ventilation with Vitovent... (cont.)

If the outdoor air falls below "**Min. temperature, geothermal heat exchanger C1AA**", the 3-way diverter damper (on site) opens up the path through the geothermal heat exchanger. Above this temperature the outdoor air flows directly into the ventilation unit without preheating.

Required enable, 3-way diverter damper (on site)

Parameter	Setting
"Preheating coil C101"	"65" or "81"

Protection against excessively high temperatures

If the outdoor air temperature rises above 60 °C, the ventilation controller either switches off both fans or only the supply air fan ("**Imbalance permitted C1A2**").

Humidity and/or CO₂ concentration control

The following sensors are required for regulating the air humidity and/or CO₂ concentration in the building:

- CO₂/humidity sensor: Installation in **a single room**
The air flow rate is adjusted subject to the air humidity and/or the CO₂ concentration **of this room**.
- Central humidity sensor: Installation in the **central extract air duct** (header)
The air flow rate is adjusted subject to the air humidity in **all the rooms**.

Note

- *The higher air flow rate is always selected if both functions are active at the same time.*
- *If air humidity control via a central humidity sensor is simultaneously active: Control via the central humidity sensor has priority.*

Air humidity/CO₂ control in a room

If the humidity in the room exceeds "**Min. voltage, input 2 C1C1**" and/or the CO₂ concentration exceeds "**Min. voltage, input 1 C1B1**" the air flow rate is increased. The air flow rate is reduced when these values are undershot.

Enabling required

Function	Parameter	Setting
Enable for processing of analogue signals at the ventilation unit intake	"Function, input 1 C1B0"	"1"
CO ₂ concentration control	"Min. voltage, input 1 C1B1"	"40" (± 4 V)
Humidity control	"Min. voltage, input 2 C1C1"	"80" (± 8 V)

Central air humidity control

If the air humidity in the central extract air duct (header) increases, "**Intensive operation**" is switched on. The original ventilation level is reapplied once the air humidity has been reduced. The response characteristics of this humidity control are set via "**Humidity sensor sensitivity C1A6**".

Enabling required

Function	Parameter	Setting
Central humidity sensor	"Humidity sensor C105"	"1"
Sensitivity	"Humidity sensor sensitivity C1A6"	≠ "0"

Photovoltaics

Power generated by the photovoltaic system can be used to operate the compressor and other heating system components (utilisation of power generated on site).

For this, the amounts of electrical energy available for the utilisation of power generated on site have to be transferred to the heat pump control unit. The following options are available for establishing data communication with the photovoltaic system:

- An energy meter (accessories) is connected to the heat pump control unit via Modbus.
- The photovoltaic system is connected to the heat pump control unit via a Smart Home system, e.g. Vitocomfort 200 (accessories).

In order to utilise power generated on site, the following heating system functions can be enabled:

- DHW heating
- Heating the buffer cylinder
- Central heating
- Cooling the heating water/coolant buffer cylinder
- Central cooling

With utilisation of power generated on site, the components connected to the heat pump control unit, such as a secondary pump, are also supplied with power from the PV system alongside the compressor.

To optimise utilisation of power generated on site, the control characteristics of the heat pump control unit are adjusted:

- The start time of enabled functions can be brought **forward** based on a demand forecast. Timing is selected so that sufficient electricity from the PV system is available. It may also be that heating of system components begins outside the set time phases of the time program.
- The set temperatures are adjusted. In addition, the start hystereses are reduced by 50 %. This enables more electrical energy from the PV to be stored in the form of thermal energy.

Note

- All safety-related temperature limits, e.g. **"Max. DHW temperature 6006"** also apply for utilisation of power generated on site.
- Set temperatures can also be adjusted via Smart Grid. If utilisation of power generated on site and Smart Grid are active at the same time, the higher set value adjustment applies: See chapter "Smart Grid".

- In heat pumps with output control, the compressor output is automatically matched to the amount of power generated by the photovoltaic system. This prevents power for operating the heat pump having to be drawn from the grid.

Note

Automatic adjustment of the compressor output is not possible with heat pump cascades.

Example:

Set value increase for DHW heating in the case of utilisation of power generated on site

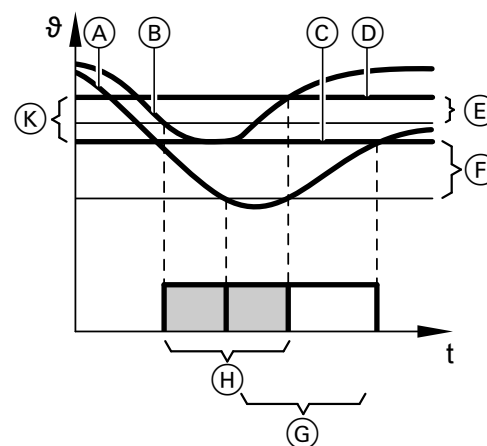

Fig. 12

- Ⓐ Temperature curve, DHW cylinder without utilisation of power generated on site
- Ⓑ Temperature curve, DHW cylinder with utilisation of power generated on site
- Ⓒ "Set DHW temperature 6000"
- Ⓓ Adjusted set temperature, DHW cylinder
- Ⓔ Reduced start hysteresis
- Ⓕ "Hysteresis DHW temperature heat pump 6007"
- Ⓖ DHW heating without utilisation of power generated on site
- Ⓗ DHW heating with utilisation of power generated on site
- Ⓚ "Raise set DHW cylinder temperature PV 7E21"

Parameters for enable and set value adjusting

Function	Release	Set value adjusting
DHW heating	"Enable own energy consumptn for set DHW temperature 2 7E10"	—
	"Enable own energy consumption for DHW heating 7E11"	"Raise set DHW cylinder temperature PV 7E21"

Photovoltaics (cont.)

Function	Release	Set value adjusting
Heating the buffer cylinder	"Enable own energy consumptn for heating water buffer cyl. 7E12"	Max. "Raise set heating water buffer cylinder temp PV 7E22"
Central heating	"Enable own energy consumption for heating 7E13"	"Raise set room temperature PV 7E23"
Cooling the heating water/coolant buffer cylinder	"Enable own energy consumptn for coolant buffer cylinder 7E16"	"Reduce set coolant buffer cylinder temperature PV 7E26"
Central cooling	"Enable own energy consumption for cooling 7E15"	"Reduce set room temperature PV 7E25"

Enabling utilisation of power generated on site

Optimisation of utilisation of power generated on site is enabled automatically if **all** of the following conditions are met:

- "Enable own energy consumption PV 7E00" is set to "1" or "2".
- The required function is enabled: See the table above.

- Over a certain period, the electrical output exported to the grid is greater than the **electrical** output of the heat pump.
- "Standby mode" and "Holiday program" are disabled.

Output matching

The compressor output can automatically match the currently available electric output from the photovoltaic system, so that the compressor does not have to draw power from the grid during utilisation of power generated on site. To this end, set "**Prop. of external current 7E02**" to a value between "0" and "9".

This output adjustment is enabled when the following conditions are met:

- The non-adjusted set temperatures have been reached. The heat pump is running to achieve the adjusted set values.
- The electrical output fed into the grid is higher than the minimum output of the compressor.

DHW heating

The set temperature for DHW heating in the case of utilisation of power generated on site is "**Set DHW temperature 6000**" plus "**Raise set DHW cylinder temperature PV 7E21**".

The heating of the DHW cylinder begins if **all** of the following conditions are met:

- Utilisation of power generated on site is enabled (see "Enabling utilisation of power generated on site").
- The temperature in the DHW cylinder falls below the adjusted set temperature by the reduced start hysteresis.
- Within the next 24 h, at least 1 time phase is set in the "**Time program DHW**".

The statistical evaluation of the user behaviour can also serve as additional start criteria: See chapter "Consideration of user behaviour".

For output-controlled compressors, the set compressor performance results directly from the available PV energy. With this default, the compressor may also run outside the efficient output range.

DHW heating with utilisation of power generated on site ends when the set constant temperature in the DHW cylinder has been reached.

Note

*If **whilst** the DHW cylinder is being heated the conditions for utilisation of power generated on site are no longer met (see "Enabling utilisation of power generated on site"), heating continues until "**Set DHW temperature 6000**" is reached. For this, the heat pump and any booster heaters required are supplied **with power from the grid**. The raising of the set temperature is no longer taken into account.*

Consideration of user behaviour

Start times for DHW heating are logged and analysed. This enables the heat pump control unit to capture patterns of utilisation.

This pattern can be taken into account for DHW heating with utilisation of power generated on site. DHW heating can then be switched on if the usage pattern indicates that a DHW demand is expected to occur in the next few hours.

A heating contractor certified by Viessmann for heat pumps can enable this function.

The start time for the next DHW heating is moved forwards, if the exported electrical output exceeds "**Threshold for electrical power 7E04**".

Photovoltaics (cont.)

DHW heating can be brought forward even if the following conditions for DHW heating would not ordinarily permit it:

- Temperature condition at the cylinder temperature sensor is **not** met: See page 40.
- DHW heating is off according to the time program.

The DHW cylinder is only heated if it is likely that sufficient power is made available by the PV system.

Heating to set DHW temperature 2

With "**Enable own energy consumptn for set DHW temperature 2 7E10**" set to "**1**", the DHW cylinder is fully heated to "**Set DHW temperature 2 600C**" with power from the photovoltaic system at least every 7 days.

Heating begins if **all** of the following conditions are met:

- On-site power consumption is enabled (see "Enabling on-site power consumption").
- The electrical energy of the PV system captured by the energy meter exceeds "**Threshold for electrical power 7E04**".
- The daily maximum of fed-in electrical power is expected within a short time.

Buffer cylinder heating

The set buffer temperature will be increased by "**Raise set heating water buffer cylinder temp PV 7E22**" if the electrical output of the photovoltaic system exceeds the "**Threshold for electrical power 7E04**".

In order to heat the buffer to the higher set buffer temperature the following conditions must be met:

- Utilisation of power generated on site is enabled: See "Enabling utilisation of power generated on site".
- The buffer temperature falls below the higher set buffer temperature by the reduced start hysteresis.
- A heat demand for the heating circuits is expected soon. For this forecast, the outside temperature curve for the previous day is evaluated.
- In "**Time prog buffer cyl**" time phase 1 is active for the next 5 h.

Central heating

"**Standard room temperature 2000**" or "**Reduced room temperature 2001**" are raised by "**Raise set room temperature PV 7E23**".

Central heating begins if **all** of the following conditions are met:

- Utilisation of power generated on site is enabled (see "Enabling utilisation of power generated on site").
- There are heat demands from the heating circuits.
- In "**Time program heating**" 1 time phase is active.

If the heat pump output is not sufficient, the instantaneous heating water heater is also switched on with power from the photovoltaic system.

Heating the DHW cylinder with on-site power ends when "**Set DHW temperature 2 600C**" is reached.

Note

*If **whilst** the DHW cylinder is being heated the conditions for on-site power consumption are no longer met (see "Enabling on-site power consumption"), heating continues until "**Set DHW temperature 2 600C**" is reached. For this, the heat pump and any booster heaters required are supplied **with power from the mains**.*

Utilisation of power generated on site for heating the buffer cylinder ends when the higher set buffer temperature is reached at the secondary circuit return temperature sensor.

Note

*The raised set buffer temperature becomes inactive if, **during** buffer heating, the conditions for utilisation of power generated on site are no longer met (see "Enabling utilisation of power generated on site"). Heating continues until the standard set buffer temperature has been reached. For this, the heat pump and any booster heaters required are supplied **with power from the grid**.*

Central heating with utilisation of power generated on site stops when there is no more heat demand from the heating circuits.

Note

Central heating continues if, **whilst** the interior is being heated, the conditions for utilisation of power generated on site are no longer met (see "Enabling utilisation of power generated on site"). The heat pump and any booster heaters required are supplied **with power from the grid**. The raising of the set temperature is no longer taken into account.

Cooling the heating water/coolant buffer cylinder

If the electrical output of the photovoltaic system exceeds the "**Threshold for electrical power 7E04**", the set buffer temperature will be reduced by the "**Reduce set coolant buffer cylinder temperature PV 7E26**", provided that the "**Min. temperature coolant buffer cylinder 722A**" is not undershot in the process.

In order to cool the heating water/coolant buffer cylinder to the reduced set buffer temperature the following conditions must be met:

- Utilisation of power generated on site is enabled: See "Enabling utilisation of power generated on site".
- The buffer temperature exceeds the reduced set buffer temperature.
- A cooling demand for the heating/cooling circuits is expected soon. For this forecast, the outside temperature curve for the previous day is evaluated.
- In "**Time prog buffer cyl**" time phase 1 is active for the next 5 h.

Utilisation of power generated on site for cooling the heating water/coolant buffer cylinder ends when the reduced set buffer temperature is reached at the secondary circuit return temperature sensor.

Note

The reduced set buffer temperature becomes inactive if, **whilst** the heating water/coolant buffer cylinder is being cooled, the conditions for utilisation of power generated on site are no longer met (see "Enabling utilisation of power generated on site"). Cooling continues until the standard set buffer temperature has been reached. To achieve this, the heat pump is supplied **with power from the grid**.

Central cooling

"**Standard room temperature 2000**" is reduced by "**Reduce set room temperature PV 7E25**".

Central cooling begins if **all** of the following conditions are met:

- Utilisation of power generated on site is enabled: See "Enabling utilisation of power generated on site".
- There is a cooling demand.
- In "**Time proghtg/cooling**" one time phase is active.

Central cooling with utilisation of power generated on site stops when there no longer is a cooling demand.

Note

Central cooling continues if, **whilst** the interior is being cooled, the conditions for utilisation of power generated on site are no longer met (see "Enabling utilisation of power generated on site"). The heat pump is supplied with **power from the grid**. The lowering of the set temperature is no longer taken into account.

Overview

	☐	⊗	⊗☐	Page
Troubleshooting				
Message overview	X	X	X	75
"Diagnosis" ▶ "System overview"				
"?" ("System information")	X	X	X	183
"Diagnosis" ▶ "System"				
"Timer"	X	X	X	120
"Integral"	X	X	X	121
"Logbook"	X	X	X	123
"Diagnosis" ▶ "Ventilation"				
"Ventilation: Overview"	X	X	X	128
"Ventilation"	X	X	X	130
"Message history" Vitovent 200-C/300-F	X	X	X	132
"Message history" Vitovent 200-W/300-C/300-F	X	X	X	135
"Diagnosis" ▶ "Heat pump"				
"Runtime compressor"	X	X	X	136
"Diagnosis" ▶ "Refrigerant circuit"				
"Refrigerant circ controller" [2] / [6]	—	X	—	137
"Refrigerant circ controller" [4]	—	X	—	139
"Refrigerant circ controller" [4-3] / [4-4]	—	—	X	141
"Refrigerant circ controller" [4-6] / [4-7]	X	—	—	143
"Refrigerant circ controller" [7] / [7-1]	—	—	X	145
"Compressor travel"	X	X	X	146
"Compressor path"	X	X	X	147
"Message history" [2]	—	X	—	148
"Message history" [4]	—	X	—	153
"Message history" [4-3] / [4-4]	—	—	X	159
"Message history" [4-6] / [4-7]	X	—	—	164
"Message history" [6]	—	X	—	172
"Message history" [7] / [7-1]	—	—	X	175
"Diagnosis" ▶ "Energy statement"				
"Diagnosis" ▶ "Photovoltaics"				
"PV statistics"	X	X	X	180
"DHW loading statistics"	X	X	X	181
"Output curves"	X	X	X	182
"Diagnosis" ▶ "Brief scan"				
"Diagnosis" ▶ "System information"				
Curves/parameters				
Temperature sensors	X	X	X	314
Pressure sensors	X	X	X	321

Overview (cont.)

	□	⊗	⊗□	Page
PCBs				
Main PCB	X	X	X	280
Expansion PCB on main PCB	X	X	X	284
Cross connect PCB	—	X	—	289
Luster terminals, Vitocal 100-S/200-A/200-S	—	—	X	292
Luster terminals, Vitocal 111-S/222-A/222-S	—	—	X	294
Luster terminals, Vitocal 222-G/333-G	X	—	—	294
Vitocal 100-S/200-A/200-S/300-A controller and sensor PCB	—	X	X	300
Controller and sensor PCB, Vitocal 111-S/222-A/222-S/222-G/333-G	X	—	X	302
EEV PCB [2]	—	X	—	304
EEV PCB [4]	—	X	—	306
EEV PCB [4-3] / [4-4]	—	—	X	307
EEV PCB [4-6] / [4-7]	X	—	—	308
Controller PCB and EEV PCB [6]	—	X	—	310
Main PCB [7] / [7-1]	—	—	X	312
Function check	X	X	X	188
Restore factory settings (reset).	X	X	X	195

Calling up messages

When there is a message, the associated message symbol flashes on the display. The message text and message code are displayed by pressing **OK**: See "Message overview".

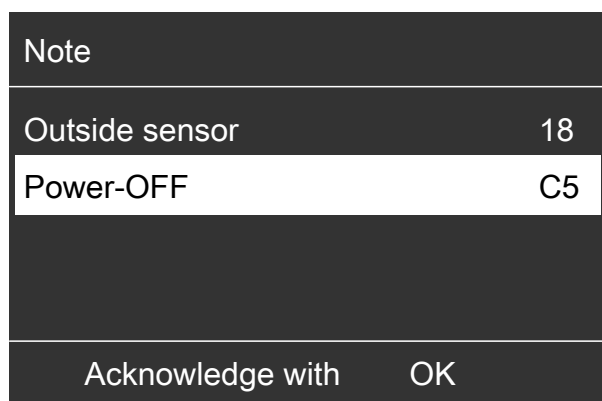

Fig. 13

Explanation of messages

Fault "△"

- In addition, the red fault indicator flashes on the heat pump control unit.
- The system is no longer in standard mode. The fault should be remedied **without delay**.
- The central fault message connection is activated.
- Message via communication interface, e.g. Vitocom, is possible

Warning "△"

The appliance operates with limited functionality. Remove the cause for the warning.

Note "👁"

The appliance is ready for use. Observe the note.

Acknowledging messages and recalling acknowledged messages



"Vitotronic 200" operating instructions

Note

- Any signalling equipment (e.g. an alarm) that is connected will be deactivated when the fault message is acknowledged.
- If the cause of the fault cannot be removed until a later time, the fault message will be redisplayed the following day. The signalling equipment is switched on again (if installed).

Calling up messages from the message history

- Messages cannot be acknowledged in the message history.
- Messages are listed in chronological order. The most recent message is listed first.
- Up to 30 entries are stored.

Calling up messages (cont.)

1. **Service menu:**
Press **OK** + **≡**: simultaneously and hold for approx. 4 s.
2. **"Message history"**
3. Call up further information on the required message with **OK**.

Note

The service menu remains active until it is deactivated with **"Terminate service?"**, or if no key is pressed for 30 min.

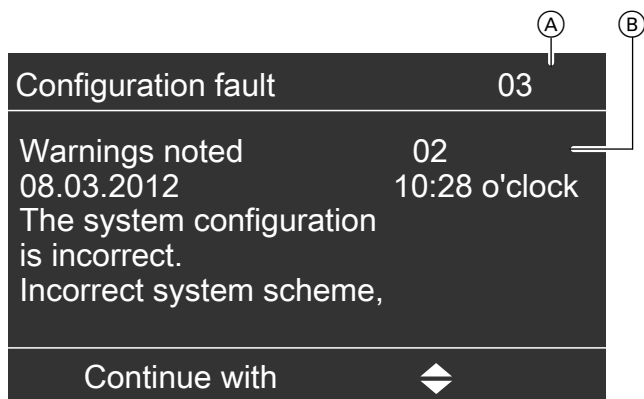

Fig. 14

- Ⓐ Message code
- Ⓑ Additional code
 - Not available for every message
 - Different interpretations are possible, depending on the message concerned

Message overview

All messages are clearly identified by a 2-digit code.

02 Data error stand.settg

Cause	Measure
Delivered condition set after recognition of data error.	Reconfigure system.

03 Configuration fault

Limited or no heat pump and/or heating system functionality

Reading an additional code

The additional 2-digit code contains further information (additional messages). **Each digit** is a hexadecimal value. The numbers of the additional messages can be read from the hexadecimal value, according to the following table.

Message overview (cont.)

No. of additional message	Hexadecimal value of the additional code															
	0	1	2	3	4	5	6	7	8	9	A	B	C	D	E	F
1	—	X	—	X	—	X	—	X	—	X	—	X	—	X	—	X
2	—	—	X	X	—	—	X	X	—	—	X	X	—	—	X	X
4	—	—	—	—	X	X	X	X	—	—	—	—	X	X	X	X
8	—	—	—	—	—	—	—	—	X	X	X	X	X	X	X	X

Values from the following example

1. Take the 1st and 2nd digits of the hexadecimal additional code.
2. Read off the numbers of the additional messages in the table above.
3. Read the additional messages in the two following tables.

Example:

Additional code read off for **"03 Configuration fault": "3C"**

Additional message numbers from the table above:

- 1st digit ("3"): 1 + 2
- 2nd digit ("C"): 4 + 8

Additional messages read from the following tables:

- 1: Incorrect system scheme for central heating...
- 2: **"Min. suction pressure 5086"** set higher...
- 4: Cascade via LON is set (**"Cascade control 700A"** set to **"2"**), although...
- 8: Parameters for circulation pumps...

Additional messages for configuration faults

1st digit of the additional code

Additional message	Cause	Measure
1st digit		
1	Incorrect system scheme for central heating via ventilation unit	Check and adjust relevant parameters. If necessary, restore factory settings (reset) and reconfigure system. Contact a heat pump specialist certified by Viessmann if the cause of the fault cannot be removed.
2	"Min. suction pressure 5086" set higher than "Low pressure limit 5099"	
4	"Dual mode temperature external heat source 7B02" set lower than "Shutdown limit, heat pump dual mode 7B0F"	
8	Parameters for ice store/solar air absorber incorrect <ul style="list-style-type: none"> ▪ Incorrect solar control unit set ("Type solar control unit 7A00"). ▪ AM1 extension not enabled ("External extension 7010") ▪ Coolant buffer cylinder is enabled at the same time 	

Values from example

Message overview (cont.)

2nd digit of the additional code

Additional message	Cause	Measure
2nd digit		
1	Incorrect system scheme (contains non-supported heating circuit)	Check and adjust relevant parameters. If necessary, restore factory settings (re-set) and reconfigure system.
2	Cooling circuit parameters incorrect <ul style="list-style-type: none"> ▪ Room temperature sensor for cooling set from unavailable remote control ▪ "Max. flow temperature heating circuit 200E" set lower than "Min. flow temperature cooling 7103" ▪ Cooling set for unavailable heating/cooling circuit ▪ Flow temperature sensor for cooling circuit not enabled ▪ Active cooling is set, despite not being supported by the heat pump ▪ Cooling is set for a heating/cooling circuit but the mixer controlled via KM-BUS is not suitable for cooling mode. 	Contact a heat pump specialist certified by Viessmann if the cause of the fault cannot be removed.
4	Cascade via LON <ul style="list-style-type: none"> ▪ "Cascade control 700A" set to "2", although "Enable LON communication module 7710" is not set to "1". ▪ 4 lag heat pumps set ("Number of lag heat pumps 7029" set to "4") and external heat generator set via LON ("Switch external heat source 7B12" set to "1" or "2") 	As for 1 and 2
8	Parameters for circulation pumps with PWM control set incorrectly	

Values from example

04 Elec. heating blocked

The instantaneous heating water heater is not started, not even for frost protection.

- !** **Please note**
 If the compressor does not start, the system may no longer be protected against frost. Ensure frost protection on site.

Cause	Measure
The prompt "Secondary circuit filled?" during enabling of the instantaneous heating water heater was answered with "No" . "Enable instantaneous heating water heater 7900" is automatically set to "2" .	Fill and vent the secondary circuit. Then enable the instantaneous heating water heater: Set "Enable instantaneous heating water heater 7900" to "1" . Confirm prompt "Secondary circuit filled?" with "Yes" .

05 Refrigerant circuit

Additional code	Cause	Action
Last message in message history, refrigerant circuit	Fault message from the refrigerant circuit controller	Observe "Diagnosis" ▶ "Refrigerant circuit" ▶ "Message history" .

Maintenance

Message overview (cont.)

07 Refrigerant circuit

Additional code	Cause	Action
Last message in message history, refrigerant circuit	Message from refrigerant circuit controller, heat pump stage 1	Observe "Diagnosis" ▶ "Refrigerant circuit" ▶ "Message history" .

09 Electricity meter PV

Utilisation of PV power generated on site not possible.

Additional code	Fault on connected electricity meter			Action
	Phase 1	Phase 2	Phase 3	
"01"	X			Have electricity meter checked by an electrical engineer.
"02"		X		
"03"	X	X		
"04"			X	
"05"	X		X	
"06"		X	X	
"07"	X	X	X	

0E Ventilation unit

"Standard operation" is switched on or ventilation unit switches off, depending on the cause of the fault.

Additional code	Cause	Action
Last message in message history, ventilation	<ul style="list-style-type: none"> ▪ Short circuit/lead break temperature sensors, ventilation unit ▪ CO₂ signal capture disrupted ▪ Communication with ventilation unit disrupted 	Observe "Diagnosis" ▶ "Ventilation" ▶ "Message history" .

0F Ventilation unit

Additional code	Cause	Action
Last message in message history, ventilation	Message from ventilation controller of the ventilation unit	Observe "Diagnosis" ▶ "Ventilation" ▶ "Message history" .

10 Outside temp. sensor

An outside temperature value of -40 °C is used to calculate the set flow temperature.

Cause	Action
Short circuit, outside temperature sensor	Check resistance value (NTC 10 kΩ) at plug F0: See "Controller and sensor PCB" .

Message overview (cont.)

18 Outside temp. sensor

An outside temperature value of $-40\text{ }^{\circ}\text{C}$ is used to calculate the set flow temperature.

Cause	Action
Lead break, outside temperature sensor	Check resistance value (NTC 10 k Ω) at plug F0: See "Controller and sensor PCB".

20 Flow sensor secondary

- Operation with temperature value of return temperature sensor in secondary circuit, plus 5 K.
- If the secondary circuit flow and return temperature sensors are faulty at the same time, the message "**A9 Heat pump**" appears and the heat pump shuts down.

Cause	Measure
Short circuit, secondary circuit flow temperature sensor	Check resistance value (Pt500A) at plug F8 or at terminals X25.9/X25.10: See "Controller and sensor PCB".

21 Return sensor secondary

- Operation with temperature value of flow temperature sensor in secondary circuit, minus 5 K.
- If the secondary circuit flow and return temperature sensors are faulty at the same time, the heat pump is switched off. After 24 h the message "**A9 Heat pump**" appears.

Cause	Measure
Short circuit, secondary circuit return temperature sensor	Check resistance value (Pt500A) at terminals X25.11/X25.12: See "Controller and sensor PCB".

24 Suction gas revers. temp.

- Heating mode:
Heat pump remains in operation.
- Cooling mode:
Compressor stops.

Cause	Measure
Short circuit, reversible suction gas temperature sensor	Check resistance value (Pt500A) at terminals X25.15/X25.16: See "Controller and sensor PCB".

25 LPG temp. sensor

Compressor stops.

Cause	Measure
Short circuit, LPG temperature sensor	Check resistance value (Pt500A) at terminals X25.17/X25.18: See "Controller and sensor PCB".

Message overview (cont.)

28 Flow sensor secondary

- Operation with secondary circuit flow temperature sensor in the appliance (if installed), e.g. with Vitocal 300-A, type AWO 301.B25 to B60.
or
 Operation with temperature value of return temperature sensor in secondary circuit, plus 5 K.
- If the secondary circuit flow and return temperature sensors are faulty at the same time, the message **"A9 Heat pump"** appears and the heat pump shuts down.

Cause	Measure
Lead break, secondary circuit flow temperature sensor	Check resistance value (Pt500A) at plug F8 or at terminals X25.9/X25.10: See "Controller and sensor PCB".

29 Return sensor secondary

- Operation with temperature value of flow temperature sensor in secondary circuit, minus 5 K.
- If the secondary circuit flow and return temperature sensors are faulty at the same time, the heat pump is switched off. After 24 h the message **"A9 Heat pump"** appears.

Cause	Measure
Lead break, secondary circuit return temperature sensor	Check resistance value (Pt500A) at terminals X25.11/X25.12: See "Controller and sensor PCB".

2C Suction gas revers. temp.

- Heating mode:
Heat pump remains in operation.
- Cooling mode:
Compressor stops.

Cause	Measure
Lead break, reversible suction gas temperature sensor	Check resistance value (Pt500A) at terminals X25.15/X25.16: See "Controller and sensor PCB".

2D Liquid gas temp sensor

Compressor stops.

Cause	Measure
Lead break, liquid gas temperature sensor	Check resistance value (Pt500A) at terminals X25.17/X25.18: See "Controller and sensor PCB".

Message overview (cont.)

30 Flow sensor primary

- Operation with temperature value of return temperature sensor in primary circuit, plus 3 K.
- If the primary circuit flow and return temperature sensors are both faulty at the same time, the message "**A9 Heat pump**" appears and the heat pump shuts down.

Cause	Measure
Short circuit, primary circuit flow temperature sensor (heat pump air intake or brine inlet)	Check resistance value (Pt500A) at terminals X25.1/ X25.2: See "Controller and sensor PCB".

31 Return sensor primary

- Operation with temperature value of flow temperature sensor in primary circuit, minus 2 K.
- If the primary circuit flow and return temperature sensors are both faulty at the same time, the message "**A9 Heat pump**" appears and the heat pump shuts down.

Cause	Measure
Short circuit, primary circuit return temperature sensor (heat pump air discharge or brine outlet)	Check resistance value (Pt500A) at terminals X25.3/ X25.4: See "Controller and sensor PCB".

32 Evaporator temp.sensr

- No central heating or central cooling; only defrosting
- The air discharge temperature sensor is used for defrosting the evaporator.

Cause	Measure
Short circuit, evaporator air intake temperature sensor	<ul style="list-style-type: none"> ▪ Vitocal 200-A, type AWCI-AC 201.A: Check resistance value Pt500A at the connection on the EEV PCB: See "EEV PCB [2]". ▪ Vitocal 100-S/111-S Check resistance value NTC 15 kΩ at the connection on the main PCB of the outdoor unit: See "Main PCB [7] / [7-1]".

36 Hot gas temp sensor 1

Compressor 1 in a 2-stage refrigerant circuit is switched OFF.

Cause	Action
The stop limit for the hot gas temperature at compressor 1 is exceeded.	<ul style="list-style-type: none"> ▪ Check the compressor oil level. Top up with oil if required. ▪ Check if there is excess oil in the oil separator. Have the refrigerant circuit checked by a refrigeration engineer if necessary.

37 Hot gas temp sensor 2

Compressor 2 in a 2-stage refrigerant circuit is switched OFF.

Cause	Action
The stop limit for the hot gas temperature at compressor 2 is exceeded.	<ul style="list-style-type: none"> ▪ Check the compressor oil level. Top up with oil if required. ▪ Check if there is excess oil in the oil separator. Have the refrigerant circuit checked by a refrigeration engineer if necessary.

38 Flow sensor primary

- Operation with temperature value of return temperature sensor in primary circuit, plus 3 K.
- If the primary circuit flow and return temperature sensors are both faulty at the same time, the message **"A9 Heat pump"** appears and the heat pump shuts down.

Cause	Measure
Lead break, flow temperature sensor, primary circuit (heat pump air or brine inlet)	Check resistance value (Pt500A) at terminals X25.1/ X25.2: See "Controller and sensor PCB".

39 Return sensor primary

- Operation with temperature value of flow temperature sensor in primary circuit, minus 2 K.
- If the primary circuit flow and return temperature sensors are both faulty at the same time, the message **"A9 Heat pump"** appears and the heat pump shuts down.

Cause	Measure
Lead break, return temperature sensor, primary circuit (heat pump air discharge or brine outlet)	Check resistance value (Pt500A) at terminals X25.3/ X25.4: See "Controller and sensor PCB".

3A Evaporator temp.sensr

- No central heating or central cooling; only defrosting
- The air discharge temperature sensor is used for defrosting the evaporator.

Cause	Measure
Lead break, evaporator air intake temperature sensor	<ul style="list-style-type: none"> ▪ Check resistance value Pt500A at the connection on the EEV PCB: See "EEV PCB [2]". ▪ Vitocal 100-S/111-S: Check resistance value NTC 15 kΩ at the connection on the main PCB of the outdoor unit: See "Main PCB [7] / [7-1]".

Message overview (cont.)

40 Flow sensor HC2

Heating circuit mixer M2/HC2 is closed.

Cause	Measure
Short circuit, flow temperature sensor, heating circuit with mixer M2/HC2	Check resistance value (NTC 10 kΩ) at plug F12: See "Controller and sensor PCB".

41 Flow sensor HC3

Mixer heating circuit M3/HC3 is closed.

Cause	Measure
Short circuit, flow temperature sensor, heating circuit with mixer M3/HC3	Check sensor: See mixer extension kit installation instructions.

43 Flow sensor system

- Flow temperature in heating circuit without mixer A1/HC1 is regulated via the return temperature sensor of the heat pump, no frost protection for this heating circuit.
- Control of flow temperature for external heat source: Temperature sensor for the buffer cylinder is used as a substitute.

Cause	Measure
Short circuit, system flow temperature sensor (downstream of buffer cylinder)	Check resistance value (NTC 10 kΩ) at plug F13: See "Controller and sensor PCB".

44 Flow sensor cooling

If "Enable flow temperature sensor cooling circuit 7109" is set to "0", cooling operation is possible, otherwise no cooling.

Cause	Measure
Short circuit, flow temperature sensor, cooling circuit	Check resistance value (NTC 10 kΩ) at plug F14: See "Controller and sensor PCB".

48 Flow sensor HC2

Heating circuit mixer M2/HC2 is closed.

Cause	Measure
Lead break, flow temperature sensor, heating circuit with mixer M2/HC2	Check resistance value (NTC 10 kΩ) at plug F12: See "Controller and sensor PCB".

Message overview (cont.)

49 Flow sensor HC3

Mixer heating circuit M3/HC3 is closed.

Cause	Measure
Lead break, flow temperature sensor, heating circuit with mixer M3/HC3	Check sensor: See mixer extension kit installation instructions.

4B Flow sensor system

- Flow temperature in heating circuit without mixer A1/HC1 is regulated via the return temperature sensor of the heat pump, no frost protection for this heating circuit.
- Mixer external heat generator does not open.

Cause	Measure
Lead break, system flow temperature sensor (downstream of buffer cylinder)	<ul style="list-style-type: none"> ▪ Check resistance value (NTC 10 kΩ) at plug F13: See "Controller and sensor PCB". ▪ If system flow temperature is not required: Check whether this sensor has been unintentionally activated ("Common flow temperature sensor system 701B").

4C Flow sensor cooling

If "**Enable flow temperature sensor cooling circuit 7109**" is set to "**0**", cooling operation is possible, otherwise no cooling.

Cause	Measure
Lead break, flow temperature sensor, cooling circuit	Check resistance value (NTC 10 kΩ) at plug F14: See "Controller and sensor PCB".

50 Cylinder sensor top

- If only the upper cylinder temperature sensor is present: No DHW heating
- If an additional lower temperature sensor is installed: DHW heating possible, switched on and off via this sensor

Cause	Measure
Short circuit, top cylinder temperature sensor	Check resistance value (NTC 10 kΩ) at plug F6 or at terminals X25.5/X25.6: See "Controller and sensor PCB".

52 Cylinder sensor bottom

- If only the lower cylinder temperature sensor is present: No DHW heating
- If an additional upper temperature sensor is installed: DHW heating possible, switched on and off via this sensor

Message overview (cont.)

Cause	Measure
Short circuit, bottom cylinder temperature sensor	Check resistance value (NTC 10 kΩ) at plug F7 or at terminals X25.7/X25.8: See "Controller and sensor PCB".

58 Cylinder sensor top

- If only the upper cylinder temperature sensor is present: No DHW heating
- If an additional lower temperature sensor is installed: DHW heating possible, switched on and off via this sensor

Cause	Measure
Lead break, top cylinder temperature sensor	Check resistance value (NTC 10 kΩ) at plug F6 or at terminals X25.5/X25.6: See "Controller and sensor PCB".

5A Cylinder sensor bottom

- If only the lower cylinder temperature sensor is present: No DHW heating
- If an additional upper temperature sensor is installed: DHW heating possible, switched on and off via this sensor

Cause	Measure
Lead break, bottom cylinder temperature sensor	Check resistance value (NTC 10 kΩ) at plug F7 or at terminals X25.7/X25.8: See "Controller and sensor PCB".

60 Buffer temp. sensor

For central heating:

- Buffer cylinder is heated once every hour.
- Heating stops when the temperature at the secondary circuit return temperature sensor reaches the set value for heating the buffer cylinder.

For central cooling with heating water/coolant buffer cylinder:

- Heating water/coolant buffer cylinder is cooled once every hour.
- Cooling stops when the temperature at the secondary circuit return temperature sensor reaches the set value for cooling the heating water/coolant buffer cylinder.

Cause	Measure
Short circuit, buffer temperature sensor	Check resistance value (NTC 10 kΩ) at plug F4: See "Controller and sensor PCB".

63 Boiler sensor ext HS

- Mixer external heat generator opens fully as soon as the external heat generator is switched on.
- Frost protection monitoring of external heat generator is not active.

Message overview (cont.)

Cause	Measure
Short circuit, external heat generator boiler water temperature sensor	Check resistance value (NTC 10 kΩ) at plug F20: See "Controller and sensor PCB".

65 Buffer outlet temp.

Operation with temperature value of flow temperature sensor in the secondary circuit of the lead heat pump

Cause	Action
Short circuit/lead break, buffer outlet temperature sensor	Check resistance value (NTC 10 kΩ) at plug F23: See "Controller and sensor PCB".

66 Swimming pool flow t.

Operation with temperature value of flow temperature sensor in the secondary circuit of the lead heat pump

Cause	Action
Short circuit/lead break, swimming pool flow temperature sensor	Check resistance value (NTC 20 kΩ) at plug F21: See "Controller and sensor PCB".

68 Buffer temp. sensor

For central heating:

- Buffer cylinder is heated once every hour.
- Heating stops when the temperature at the secondary circuit return temperature sensor reaches the set value for heating the buffer cylinder.

For central cooling with heating water/coolant buffer cylinder:

- Heating water/coolant buffer cylinder is cooled once every hour.
- Cooling stops when the temperature at the secondary circuit return temperature sensor reaches the set value for cooling the heating water/coolant buffer cylinder.

Cause	Measure
Lead break, buffer temperature sensor	Check resistance value (NTC 10 kΩ) at plug F4: See "Controller and sensor PCB".

6B Boiler temp.sensor ext

- Mixer external heat generator opens fully as soon as the external heat generator is switched on.
- Frost protection monitoring of external heat generator is not active.

Cause	Measure
Lead break, external heat generator boiler water temperature sensor	Check resistance value (NTC 10 kΩ) at plug F20: See "Controller and sensor PCB".

6E Flow sens condenser

- No central cooling, no defrosting
- Max. flow temperature in secondary circuit: Secondary circuit return temperature plus 5 K

Message overview (cont.)

Cause	Measure
Short circuit/lead break, secondary circuit flow temperature sensor upstream of the instantaneous heating water heater	Check resistance value (Pt500A) at connection X25.3/ X25.4: See "Controller and sensor PCB".

70 Room temp. sensor HC1

- No frost protection mode via room temperature sensor
- No room temperature hook-up
- No room temperature-dependent control

Cause	Measure
Short circuit, room temperature sensor, heating circuit without mixer A1/HC1	Check remote control. Replace remote control if required: See "Vitotrol" installation and service instructions.

71 Room temp. sensor HC2

- No frost protection mode via room temperature sensor
- No room temperature hook-up
- No room temperature-dependent control

Cause	Measure
Short circuit, room temperature sensor, heating circuit with mixer M2/HC2	Check remote control. Replace remote control if required: See "Vitotrol" installation and service instructions.

72 Room temp. sensor HC3

- No frost protection mode via room temperature sensor
- No room temperature hook-up
- No room temperature-dependent control

Cause	Measure
Short circuit, room temperature sensor, heating circuit with mixer M3/HC3	Check remote control. Replace remote control if required: See "Vitotrol" installation and service instructions.

73 Room temp. sensor SKK

No cooling mode

Cause	Measure
Short circuit, room temperature sensor, cooling circuit	Check resistance value (NTC 10 kΩ) at plug F16 (see "Controller and sensor PCB") or on remote control unit.

Message overview (cont.)

78 Room temp. sensor HC1

- No frost protection mode via room temperature sensor
- No room temperature hook-up
- No room temperature-dependent control

Cause	Measure
Lead break, room temperature sensor, heating circuit without mixer A1/HC1	Check remote control. Replace remote control if required: See "Vitotrol" installation and service instructions.

79 Room temp. sensor HC2

- No frost protection mode via room temperature sensor
- No room temperature hook-up
- No room temperature-dependent control

Cause	Measure
Lead break, room temperature sensor, heating circuit with mixer M2/HC2	Check remote control. Replace remote control if required: See "Vitotrol" installation and service instructions.

7A Room temp. sensor HC3

- No frost protection mode via room temperature sensor
- No room temperature hook-up
- No room temperature-dependent control

Cause	Measure
Lead break, room temperature sensor, heating circuit with mixer M3/HC3	Check remote control. Replace remote control if required: See "Vitotrol" installation and service instructions.

7B Room temp. sensor SKK

No cooling mode

Cause	Measure
Lead break, room temperature sensor, cooling circuit	Check resistance value (NTC 10 kΩ) at plug F16 (see "Controller and sensor PCB") or on remote control unit.

90 Solar module sensor 7

No switching of the appliance connected at plug 22 of the solar control module, type SM1 (circulation pump or 3-way diverter valve)

Cause	Action
Short circuit, temperature sensor 7 at solar control module, type SM1	Check sensor 7 on solar control module, type SM1: See installation and service instructions for solar control module, type SM1.

Message overview (cont.)

91 Solar module sensor 10

No switching of the appliance connected at plug **22** of the solar control module, type SM1 (circulation pump or 3-way diverter valve)

Cause	Action
Short circuit, temperature sensor 10 at solar control module, type SM1	Check sensor 10 on solar control module, type SM1: See installation and service instructions for solar control module, type SM1.

94 Cylinder sensor solar

No solar DHW heating with solar control module, type SM1

Cause	Action
Short circuit, cylinder temperature sensor at solar control module, type SM1	Check sensor 5 on solar control module, type SM1: See installation and service instructions for solar control module, type SM1.

98 Solar module sensor 7

No control of the appliance (circulation pump or 3-way diverter valve) connected to plug **22** on the solar control module, type SM1

Cause	Action
Short circuit, temperature sensor 7 at solar control module, type SM1	Check sensor 7 on solar control module, type SM1: See installation and service instructions for solar control module, type SM1.

99 Solar module sensor 10

No switching of the appliance connected at plug **22** of the solar control module, type SM1 (circulation pump or 3-way diverter valve)

Cause	Action
Lead break, temperature sensor 10 at solar control module, type SM1	Check sensor 10 on solar control module, type SM1: See installation and service instructions for solar control module, type SM1.

9A Collector temp. sensor

No solar DHW heating with solar control module, type SM1

Cause	Measure
Lead break, collector temperature sensor, solar control module, type SM1	Check sensor 6 on solar control module, type SM1: See installation and service instructions for "Solar control module, type SM1".

Message overview (cont.)

9C Cylinder sensor solar

No solar DHW heating with solar control module, type SM1

Cause	Action
Lead break, cylinder temperature sensor at solar control module, type SM1	Check sensor 5 on solar control module, type SM1: See installation and service instructions for solar control module, type SM1.

9E Delta T mon. solar

No solar DHW heating with solar control module, type SM1

Cause	Action
<ul style="list-style-type: none"> ▪ Insufficient or no flow rate in the solar circuit or ▪ Temperature limiter has responded. 	Check solar circuit pump 24 on solar control module, type SM1: See installation and service instructions for solar control module, type SM1.

9F Internal fault, solar

No solar DHW heating with solar control module, type SM1

Cause	Action
Fault, solar control module, type SM1	Replace solar control module, type SM1.

A0 Ventilation. Check filter(s)

Mechanical ventilation in control mode

Cause	Measure
<ul style="list-style-type: none"> ▪ Outdoor air and extract air filter on ventilation unit contaminated ▪ Last filter change was more than 1 year ago. 	<ul style="list-style-type: none"> ▪ Vitovent 200-C/300-F: Replace outdoor air and extract air filters. Do not clean filters. ▪ Vitovent 200-W/300-C/300-W: Clean outdoor air and extract air filters. In the event of severe contamination replace both filters at least once every 12 months.

A1 compressor 1

Compressor 1 in a 2-stage refrigerant circuit is switched OFF.

Cause	Action
<p>One of the following events has occurred 9 times:</p> <ul style="list-style-type: none"> ▪ High pressure limit exceeded ▪ High pressure limit not reached ▪ Excessively high hot gas temperature ▪ Low pressure limit undershot ▪ Flow switch has responded. ▪ Suction gas superheating too low 	<ul style="list-style-type: none"> ▪ Scanning further heat pump messages: "Message history" ▪ Observe messages from the refrigerant circuit controller: "Diagnosis" ▶ "Refrigerant circuit" ▶ "Message history" ▪ Check flow rates. ▪ Check motor currents/motor overload relay. ▪ Check safety high pressure switch.

Message overview (cont.)

Cause	Action
<ul style="list-style-type: none"> ▪ Motor overload relay has responded. ▪ Compressor was switched OFF by the refrigerant circuit controller. <p>Note The event counter is reset as soon as the compressor has been operational continuously once for "Optimum runtime compressor 500A".</p>	<ul style="list-style-type: none"> ▪ Check the compressor oil level. Top up with oil if required. ▪ Check if there is excess oil in the oil separator. Have the refrigerant circuit checked by a refrigeration engineer if necessary. <p>Note After removing the fault, switch the appliance first off and then on again.</p>

A2 compressor 2

Compressor 2 in a 2-stage refrigerant circuit is switched OFF.

Cause	Action
<p>One of the following events has occurred 9 times:</p> <ul style="list-style-type: none"> ▪ High pressure limit exceeded ▪ High pressure limit not reached ▪ Excessively high hot gas temperature ▪ Low pressure limit undershot ▪ Flow switch has responded. ▪ Suction gas superheating too low ▪ Motor overload relay has responded. ▪ Compressor was switched OFF by the refrigerant circuit controller. <p>Note The event counter is reset as soon as the compressor has been operational continuously once for "Optimum runtime compressor 500A".</p>	<ul style="list-style-type: none"> ▪ Scanning further heat pump messages: "Message history" ▪ Observe messages from the refrigerant circuit controller: "Diagnosis" ► "Refrigerant circuit" ► "Message history" ▪ Check flow rates. ▪ Check motor currents/motor overload relay. ▪ Check safety high pressure switch. ▪ Check the compressor oil level. Top up with oil if required. ▪ Check if there is excess oil in the oil separator. Have the refrigerant circuit checked by a refrigeration engineer if necessary. <p>Note After removing the fault, switch the appliance first off and then on again.</p>

A6 Secondary pump

- No flow rate in the secondary circuit: Secondary pump is not running.
- The change in the secondary circuit flow temperature for central heating/cooling is insufficient.

Message overview (cont.)

Cause	Measure
<ul style="list-style-type: none"> ▪ Secondary pump mechanical fault ▪ Secondary pump electrical fault ▪ Secondary pump run dry 	<p>Carry out mechanical check of secondary pump.</p> <p>Measure the voltage at the following connections:</p> <ul style="list-style-type: none"> ▪ Vitocal 222-G: Connections J5 and J17 on the EEV PCB: See "EEV PCB [4-6] / [4-7]". ▪ Vitocal 333-G: Connections J5 and J20 on the EEV PCB: See "EEV PCB [4-6] / [4-7]". ▪ Other heat pumps: Connection 211.2: See "Main PCB". <p>Replace the secondary pump if required.</p>

A8 Heating circ. pump HC1

Temperature increase in heating circuit without mixer A1/HC1.

Cause	Measure
No flow (circulation pump shut down).	Measure voltage at terminal 212.2 (see "main PCB") and check pump mechanically; replace if necessary.

A9 Heat pump

- Compressor is switched off.
- Central heating and DHW heating occurs with other heat sources enabled for this purpose, e.g. an external heat generator or instantaneous heating water heater.
- The operation with booster heaters depends on the setting "**Operating status after message A9, C9 701C**".

Cause	Measure
<ul style="list-style-type: none"> ▪ Heat pump faulty ▪ Safety high pressure switch has responded: See "C9 Refrigerant circ (SHD)". ▪ One of the following events has occurred: <ul style="list-style-type: none"> – High pressure limit was exceeded 3 times within 60 min (Vitocal 100-S/111-S only). – Low pressure limit was undershot twice within 40 min (Vitocal 100-S/111-S only). – Flow switch has responded 9 times. – Compressor was switched off by the refrigerant circuit controller 9 times. – Defrosting process was terminated. <p>Note The event counter is reset as soon as the compressor has been operational continuously once for "Optimum runtime compressor 500A".</p> <ul style="list-style-type: none"> ▪ Safety chain is interrupted for more than 24 h. ▪ Event that leads to the compressor being switched off is active for more than 24 h. ▪ Primary/secondary circuit flow and return temperature sensors are simultaneously faulty for more than 24 h. 	<ul style="list-style-type: none"> ▪ Calling up further heat pump messages: "Message history" ▪ Observe messages from the refrigerant circuit controller: "Diagnosis" ► "Refrigerant circuit" ► "Message history" ▪ Check flow rates. ▪ Check safety high pressure switch. ▪ Check flow and return temperature sensors in the primary/secondary circuit. <p>Note After removing the fault, switch the appliance first off and then on again.</p>

Message overview (cont.)

AA Cancel defrost

- ⊗🔧: Compressor remains off until the flow temperature in the secondary circuit has reached 15 °C. Booster heaters are started if necessary (instantaneous heating water heater or external heat generator).
- ⊗: Switch to central heating/DHW heating

Cause	Measure
<ul style="list-style-type: none"> ▪ Flow or return temperature in the secondary circuit too low during defrosting ▪ The pipework flow rate may be too low 	<p>Provide additional heating water buffer cylinder in the secondary circuit return.</p> <p>! Please note If the temperature in the secondary circuit is too low, the condenser may freeze up or a thick layer of ice may form on the evaporator. Only acknowledge the fault message when the flow temperature in the secondary circuit has reached at least 15 °C.</p>

AB Instant.htg wtr heater

Instantaneous heating water heater does not start up.

Cause	Measure
<ul style="list-style-type: none"> ▪ Instantaneous heating water heater faulty ▪ High limit safety cut-out has responded. ▪ No temperature rise within 24 h 	<p>! Danger Contact with live components can lead to serious injury from electric current. Isolate the power supply prior to starting work on the appliance.</p> <ul style="list-style-type: none"> ▪ Check power supply, connecting cable and plug for the instantaneous heating water heater. ▪ Check instantaneous heating water heater control signal at terminals 211.3 (stage 1, see "Main PCB") and 224.4 (stage 2, see "Expansion PCB"). ▪ Check high limit safety cut-out, and reset if required. ▪ Check instantaneous heating water heater.

AC compressor block

- The compressor shuts down permanently in order to prevent appliance damage.
- Central heating and DHW heating is only possible with booster heaters.

Cause	Measure
<ul style="list-style-type: none"> ▪ Temperature sensors in the refrigerant circuit are faulty ▪ Pressure sensor faulty ▪ Safety high pressure switch has responded. ▪ Electronic expansion valve faulty ▪ Compressor drive faulty ▪ ⊗🔧: Fan faulty 	<ul style="list-style-type: none"> ▪ Calling up further heat pump messages: "Message history" ▪ Observe messages from the refrigerant circuit controller: "Diagnosis" ▶ "Refrigerant circuit" ▶ "Message history" ▪ Check temperature sensors in the refrigerant circuit. ▪ Check pressure sensor. ▪ Check safety high pressure switch. ▪ Check electronic expansion valve. ▪ Check compressor drive.

Message overview (cont.)

AD Mixer heating/DHW

No changeover between heating mode and DHW heating.

Cause	Measure
3-way diverter valve "Heating/DHW heating" is faulty.	Check function of 3-way diverter valve (see "Function check") Check voltage at terminal 211.4 (see "main PCB"); replace 3-way diverter valve if necessary.

AE Cyl sensor top/bottom

Cause	Measure
Top and bottom temperature sensors interchanged in the DHW cylinder.	No action required. Heat pump control unit interchanges the sensors internally.

AF Cylinder primary pump

Inadequate change of temperature in the DHW cylinder

Cause	Measure
<ul style="list-style-type: none"> ▪ Circulation pump for cylinder heating faulty ▪ Cylinder loading system flow rate too low; cylinder loading pump or 2-way valve on cylinder loading system faulty 	Measure the voltage at the following connections: <ul style="list-style-type: none"> ▪ Vitocal 300-A: Connection 224.6, see "Expansion PCB". ▪ Other heat pumps: Connection 211.4, see "Main PCB". Check circulation pumps and 2-way valve are mechanically sound. If necessary replace circulation pumps and/or 2-way valve.

B0 Device recognition

- Heat pumps with refrigerant circuit controller [7-1]: Heat pump starts. Refrigerant circuit runs with reduced efficiency.
- Other heat pumps: The heat pump does **not** start.

Message overview (cont.)

Cause	Measure
<ul style="list-style-type: none"> ▪ Parameter "5030 Output compressor stage" is set incorrectly. ▪ Error in recognising appliance version, incorrect coding card or PCBs faulty <p>Vitocal 300-A, type AWO-AC 301.B:</p> <ul style="list-style-type: none"> ▪ Cable harness for pressure sensor and fill level sensor in refrigerant collector faulty ▪ Charge level sensor of refrigerant collector faulty 	<ul style="list-style-type: none"> ▪ Correct setting for "5030 Output compressor stage". ▪ Check the coding card: See "Controller and sensor PCB". Replace the coding card if necessary. ▪ Check PCBs. Replace PCBs if required. ▪ Vitocal 100-S/111-S: Check the ID of the jumper (blue) on the main PCB of the outdoor unit: See chapter "Main PCB [7] / [7-1]". ▪ Vitocal 200-A/200-S/222-A/222-S: Check the DIP switch on the EEV PCB of the outdoor unit: See chapter "EEV PCB [4-3] / [4-4]". ▪ Vitocal 222-G/333-G: Check the DIP switch on the EEV PCB: See chapter "EEV PCB [4-6] / [4-7]". ▪ Vitocal 300-A, type AWO-AC 301.B: Check cable harness and/or fill level sensor for refrigerant collector: See chapter "EEV PCB [4]". <p>Note <i>After removing the fault, switch appliance off and on again.</i></p>

B4 AD converter

Heat pump does not start.

Cause	Measure
Internal fault ADC (analogue digital converter, reference), ribbon cable between sensor PCB and main PCB faulty, or PCBs faulty.	<p>Check PCB; if necessary, replace in the following order: Controller and sensor PCB, main PCB.</p> <p>Note <i>After removing the fault, switch appliance off and on again.</i></p>

B5 Hardware

Heat pump does not start.

Additional code	Cause	Measure
DF	Flash memory fault, main PCB.	Replace main PCB (see "main PCB").

BF Communication module

No communication via LON.

Cause	Measure
<ul style="list-style-type: none"> ▪ Incorrect LON communication module. ▪ Incorrect wiring in LON 	<ul style="list-style-type: none"> ▪ Replace LON communication module. ▪ Check wiring in LON and correct if required.

Message overview (cont.)

C2 Power supply

Compressor stops.

Cause	Measure
Compressor power supply fault or phase monitor faulty	<p>Check connections, power supply and phase connection. Check phase monitor.</p> <p>The switching signal of the phase monitor can be checked at terminal 215.2: See "Main PCB".</p> <p>0 V Fault 230 V~ No fault</p>

C3 Pressure switch prim.

Compressor stops.

Cause	Measure
Pressure in primary circuit too low	<p>Check the primary circuit for pressure, flow rate and leaks. Top up heat transfer medium if necessary. If no pressure switch is installed in the primary circuit, insert a jumper across X3.8/X3.9: See "Luster terminals".</p> <p>The signal from the pressure switch can be measured at terminals X3.8/X3.9 against X2.N.</p> <p>0 V Pressure switch has responded. 230 V~ Pressure switch has not responded.</p>

C5 Power-OFF

Compressor stops.

Cause	Measure
Power-OFF active (triggered by power supply utility)	<p>No action required. If the message is constantly present: Check connection at terminal X3.7 (feed) first, then at terminal X3.6 (230 V~) (see "Cross connect PCB"/"Luster terminals").</p>

C9 Refrigerant circ (SHD)

- Compressor is switched off.
- Central heating and DHW heating occurs with other heat sources enabled for this purpose, e.g. an external heat generator or instantaneous heating water heater.
- The operation with booster heaters depends on the setting "**Operating status after message A9, C9 701C**".

Cause	Measure
<p>Refrigerant circuit fault:</p> <ul style="list-style-type: none"> ▪ Safety high pressure switch has responded. ▪ Fan faulty ▪ Primary pump faulty 	<ul style="list-style-type: none"> ▪ Check flow and return temperature sensors in primary and secondary circuits. ▪ Check primary and secondary circuits for pressure and flow rate: See message "A9 Heat pump".

Message overview (cont.)

Cause	Measure
	<ul style="list-style-type: none"> ▪ Have the heat pump checked by a refrigeration engineer. ▪ Check fan or primary pump. <p>Check safety high pressure switch.</p> <ul style="list-style-type: none"> ▪ Vitocal 100-S/111-S: The switching signal of the safety high pressure switch can be tested at connection "H_Press" on the main PCB of the outdoor unit: See "Main PCB [7] / [7-1]". 0 V High pressure switch has responded. 230 V~ High pressure switch has not responded. ▪ Vitocal 200-A/200-S/222-A/222-S/333-G: The continuity of the safety high pressure switch can be tested at the inverter. ▪ Vitocal 200-A, type AWCI-AC 201.A, Vitocal 222-G, Vitocal 300-A, type AWO-AC 301.B: The switching signal of the safety high pressure switch can be checked at terminal 215.4: See "Main PCB". 0 V High pressure switch has responded. 230 V~ High pressure switch has not responded. ▪ Vitocal 300-A, type AWO 302.B: Connections XF4.1/XF4.2: See separate wiring diagram. <p>Note <i>After removing the fault, switch the heat pump first off and then on again.</i></p>

CA Protectn device primry

Compressor stops.

Cause	Measure
<ul style="list-style-type: none"> ▪ □: Primary circuit pressure switch or frost stat has responded. ▪ ⊗: Faulty power supply to fan ▪ ⊗: Fan blocked or faulty ▪ Contact humidistat has responded. 	<ul style="list-style-type: none"> ▪ Check safety equipment at terminals X3.8 and X3.9: See "cross connect PCB"/"luster terminals". In systems without safety equipment or if the 24 V= contact humidistat is used at F11, check jumper between X3.9/X3.8. ▪ If the following contact humidistats are used for cooling, check jumper at plug F11: <ul style="list-style-type: none"> - Contact humidistat 230 V~, connection to X3.8/X3.9 - 24 V= contact humidistat, connection to NC-Box ▪ □: Check primary circuit. Check primary pump and/or well pump. Replace the pump if required. ▪ ⊗: Check electrical connections at the fan. Carry out mechanical check of fan. <p>The switching signal can be tested at terminal 215.3: See "Main PCB". 0 V Fault 230 V~ No fault</p>

Message overview (cont.)

CB Flow temp. primary

Compressor stops.

Cause	Measure
Min. flow temperature in primary circuit (brine inlet/air intake) not achieved.	<ul style="list-style-type: none"> ▪ □: Check primary circuit flow rate. ▪ ⊗: Outside temperature outside the application limits, no measures required.

CC Coding card

Heat pump does not start.

Cause	Measure
Coding card cannot be read.	<ul style="list-style-type: none"> ▪ Check coding card: Switch off heat pump and check whether coding card has been inserted correctly; reinsert if necessary. Replace coding card if test was unsuccessful. ▪ Check controller and sensor PCB and replace if necessary.

CF Communication module

No communication via LON.

Cause	Measure
LON communication module not plugged in or faulty.	<p>If necessary, replace components in the following order:</p> <ul style="list-style-type: none"> ▪ LON communication module. ▪ Controller and sensor PCB.

D1 Compressor safety





Compressor stops.

Cause	Measure
<p>Compressor fault:</p> <ul style="list-style-type: none"> ▪ Separate compressor motor overload relay (if installed) has responded. ▪ Motor overload relay has responded. 	<ul style="list-style-type: none"> ▪ Check compressor power connections. Check the winding resistance of the compressor motor. Check phase sequence on compressor. <p>The switching signal of the motor overload relay can be checked at connection 215.7: See "Main PCB".</p> <p>0 V Motor overload relay has responded. 230 V~ Motor overload relay has not responded.</p> <p>Note <i>The internal motor overload relay prevents re-enabling of the compressor for 1 to 3 h if the motor overheats.</i></p>

Message overview (cont.)

D3 Low pressure

Compressor stops.

Cause	Measure
<p>Low pressure fault:</p> <ul style="list-style-type: none"> ▪ Heat pump faulty ▪ Low pressure switch has responded. ▪ Low pressure sensor has reported a fault. ▪ Low pressure sensor faulty ▪ : Fan blocked or faulty ▪ Evaporator contaminated ▪ : Primary pump faulty 	<ul style="list-style-type: none"> ▪ Clean the evaporator. ▪ : Check fan. ▪ : Check pressure gauge, primary pump and shut-off facilities. ▪ Check low pressure switch/sensor at the following connections: <ul style="list-style-type: none"> - Vitocal 100-S/111-S: "LPP" connection on the main PCB: See "Main PCB [7] / [7-1]". - Vitocal 200-A/200-S/222-A/222-S: Connection J10 on EEV PCB: See "EEV PCB [4-3] / [4-4]". - Vitocal 200-A, type AWCI-AC 201.A: Connection J4 on the EEV PCB: See "EEV PCB [2]". - Vitocal 222-G/333-G: Connection J10 on EEV PCB: See "EEV PCB [4-6] / [4-7]". - Vitocal 300-A, type AWO-AC 301.B: Connection J10 on the EEV PCB: See "EEV PCB [4]". - Vitocal 300-A, type AWO 302.B: Connections J4 and J7 on the controller PCB: See "Controller PCB [6]". ▪ Check cable and main PCB/EEV PCB. Replace PCB if required. See "Main PCB [7] / [7-1]", "EEV PCB [4-3] / [4-4]" or "EEV PCB [4-6] / [4-7]". ▪ Have the heat pump checked by a refrigeration engineer.

D4 Control high pressure

Compressor stops.

Cause	Measure
<p>High pressure fault:</p> <ul style="list-style-type: none"> ▪ Air in heating circuit ▪ Secondary pump or heating circuit pump blocked ▪ Condenser contaminated ▪ High pressure sensor faulty 	<ul style="list-style-type: none"> ▪ Vent heating circuit. ▪ Check the system pressure. ▪ Check secondary pump and heating circuit pumps. ▪ Flush heating circuits.



Message overview (cont.)

Cause	Measure
	<ul style="list-style-type: none"> ▪ Reduce set cylinder temperature ("Set DHW temperature 6000", "Set DHW temperature 2 600C") by 2 to 3 K. ▪ Check high pressure sensor at the following connections of the outdoor unit: <ul style="list-style-type: none"> – Vitocal 100-S/111-S: "H_PRESS" connection on the main PCB: See "Main PCB [7] / [7-1]". – Vitocal 200-A/200-S/222-A/222-S: Connection J10 on EEV PCB: See "EEV PCB [4-3] / [4-4]". – Vitocal 200-A, type AWCI-AC 201.A: Connection J3 on the EEV PCB: See "EEV PCB [2]". – Vitocal 222-G/333-G: Connection J10 on EEV PCB: See "EEV PCB [4-6] / [4-7]". – Vitocal 300-A, type AWO-AC 301.B: Connection J10 on the EEV PCB: See "EEV PCB [4]". – Vitocal 300-A, type AWO 302.B: Connection J5 on the controller PCB: See "Controller PCB [6]". <p>Note <i>In rare cases, e.g. during DHW heating, a high pressure fault can occur. If this occurs several times in succession, check the heat pump and parameter settings of the refrigerant circuit.</i></p>

D5 Contact humidistat

Compressor stops.

Cause	Measure
<p>Contact humidistat has responded.</p>	<p>Check 24 V– contact humidistat at plug F11: See "Controller and sensor PCB".</p> <p>0 V Fault 24 V– No fault</p> <p>Note <i>If the 230 V~ contact humidistat at X3.8/X3.9 is used for cooling, check the jumper at plug F11.</i></p>

Message overview (cont.)

D6 Flow switch

Compressor stops.

Cause	Measure
<p>Minimum flow rate in secondary circuit is undershot: See heat pump specification.</p> <p> Heat pump specification Heat pump installation and service instructions</p>	<ul style="list-style-type: none"> ▪ Check secondary circuit flow rate. ▪ Check secondary pump. <p>If no flow switch is installed, insert a jumper across X3.3/X3.4: See "Luster terminals" or "Cross connect PCB".</p> <p>The flow switch signal can be checked against X2.N at terminal 216.3 (see "Main PCB") or at terminals X3.3/ X3.4.</p> <p>0 V Flow switch has responded. 230 V~ Flow switch has not responded.</p>

D7 Flow switch

Heat pump does not start.

Cause	Measure
<ul style="list-style-type: none"> ▪ Flow switch faulty ▪ Flow switch is sticking. ▪ Jumper across X3.3/X3.4 is inserted. 	<ul style="list-style-type: none"> ▪ Check flow switch. ▪ Remove jumper between X3.3/X3.4. Connect flow switch: See "cross connect PCB" or "luster terminals".

E0 LON subscriber

No communication with the subscriber via LON

Cause	Action
<p>Connection to LON subscriber is faulty.</p>	<ul style="list-style-type: none"> ▪ Carry out subscriber check (See "LON subscriber check"). ▪ Check system and subscriber numbers ("LON system number 7798", "LON subscriber number 7777"). ▪ Check connections and LON connecting lines.

E1 External heat source

Heat pump control unit cannot start external heat source.

Cause	Measure
<ul style="list-style-type: none"> ▪ External heat generator fault ▪ Short circuit/lead break, boiler water temperature sensor in external heat generator 	<ul style="list-style-type: none"> ▪ Check external heat source. ▪ Check resistance value (NTC 10 kΩ) at plug F20: See "Controller and sensor PCB".

Message overview (cont.)

E6 Fault at LON subscr.

No communication via LON with the subscriber, e.g. a lag heat pump of a heat pump cascade

Cause	Measure
Fault at LON subscriber	Read message memory at faulty LON subscriber. Rectify fault at LON subscriber.

EE KM BUS subscriber

Cause	Measure
Communication with a KM BUS subscriber not possible.	Check KM BUS subscriber list (" Service functions " ► " KM-BUS subscriber ").

EF Modbus subscriber

Cause	Measure
Communication with a Modbus subscriber not possible.	Check Modbus1 and Modbus 2 subscriber lists (" Service functions " ► " Modbus1 subscriber "/" Modbus2 subscriber ").

F2 Parameters 5030/5130

Energy statement not calculated correctly.

Cause	Measure
Compressor output not set.	Set " Output compressor stage 5030/5130 " parameter accordingly.

FF New start

Information display, no restriction of functions: Indicates that the heat pump has been re-started.

Cause	Measure
<ul style="list-style-type: none"> ▪ Heat pump control unit restart ▪ If this occurs unexpectedly: Brief interruptions in the power supply, e.g. loose contacts 	<p>After restart: No action required</p> <p>If this occurs unexpectedly:</p> <ul style="list-style-type: none"> ▪ Check power supply of heat pump control unit. ▪ Check ribbon cable in heat pump control unit.

Nothing displayed on programming unit display

- | | |
|--|---|
| <ol style="list-style-type: none"> 1. Switch ON system ON/OFF switch. 2. Check heat pump control unit fuse; replace if necessary. 3. Check whether there is power at the heat pump control unit; switch on power supply if necessary. 4. Check the plug-in and threaded connections. | <ol style="list-style-type: none"> 5. Replace programming unit if necessary. 6. Replace controller and sensor PCB if necessary. <p> Installation and service instructions of the relevant heat pump.</p> |
|--|---|

Diagnosis (service scans)

The following operating data is available in the individual groups:

- Temperature values
- Status information, e.g. ON/OFF
- Hours run
- Diagnosis overviews

Note

The type and number of menu entries depend on the heat pump, heating system and current parameter settings.

- ▶ *Scroll to the right in order to display the required information.*

Calling up a diagnosis

- 1. Service menu:**
Press **OK** +  simultaneously and hold for approx. 4 s.
- 2. "Diagnosis"**
- 3.** Select the required group, e.g. **"Heat pump"**.

Diagnosis (service scans) (cont.)

Menu overview "Diagnosis"

"System overview": See chapter "System overview".

"System"

"Timer" ▶	See chapter "System", "Timer".
"Integral" ▶	See chapter "System", "Integrals".
"Logbook" ▶	See chapter "System", "Logbook".
"Outside temperature" ▶	"Adjusted"/"Actual"
"Common flow temperature" ▶	"Set"/"Actual"
"Operating status system" ▶	
"Time prog. noise red." ▶	
"Heating season"	
"Cooling period"	
"Htg wtr buffer cyl"	
"Buffer cyl operating mode" ▶	
"Op. status buffer cylinder" ▶	
"Time prog buffer cyl" ▶	
"Coolant buffer op. status"	
"Time prog. coolnt buff cyl."	
"Valve heating/cooling"	
"Coolant buffer flow t"	
"Active cooling"	
"Natural cooling"	
"External heat source" ▶	"Temperature"/"Condition"/"Hours run"
"Mixer external HS"	
"Alt. mode ext. HS"	
"Time prog elec heater"	
"Central fault"	
"Op. status swimming pool" ▶	
"Sw. pool heat demand"	
"Swimming pool heating"	
"Lag heat pump 1/2/3/4"	
"Coding card"	
"Subscriber no."	
"Ext. hook-up 0..10V"	
"Time"	
"Date"	
"Radio clock signal"	
"Screed drying days"	

Diagnosis (service scans) (cont.)

"Heating circuit 1", "Heating circuit 2", "Heating circuit 3", "Cooling circuit SKK"

"Operating program" ▶ "Operating program"/"Operating status"
"Time program heating" ▶
"Time progthg/cooling" ▶
"Set room temp."
"Room temperature"
"Set red. room temp"
"Set party temperature"
"Heating curve" ▶ "Slope"/"Level "
"Heating circuit pump" (status)
"Heating circuit pump" (pump rate in %)
"Holiday program" ▶ "Leaving date"/"Return date"
"Mixer"
"Flow temperature"
"Set flow temperature"
"Cooling curve" ▶ "Slope" / "Level "
"Active cooling"
"Natural cooling"
"Mixer cooling"
"Flow temp. cooling"
"Heating season"
"Cooling period"
"Heating demand"
"Cooling demand"

"DHW"

"Operating program" ▶ "Operating program"/"Operating status"
"Time program DHW" ▶
"Time prog DHW circ" ▶
"DHW temperature" ▶ "Set DHW temperature"/"Cylinder temp. top"/"Cylinder temp. bottom"
"Cylinder primary pump" (status)
"Cylinder primary pump" (pump rate in %)
"DHW circulation pump"
"1x DHW heating"
"Cylinder reheating" (status)
"Cylinder reheating" (hours run)

Diagnosis (service scans) (cont.)

"Ventilation"

"Operating program" ▶ "Operating program"/"Operating status"
"Time prog ventilation" ▶
"Set room temp." ("Set room temperature 7D08"/"Set room temperature C108")
"Ventilation: Overview" ▶: See chapter "Ventilation", "Ventilation: Overview".
"Ventilation" ▶: See chapter "Ventilation", "Ventilation".
"Min supply air t. byp" ("Min. supply air temperature for bypass 7D0F")
"Heat recovery level"
"Humidity"
"El. preheater bank" (heating output in %)
"Days to filter change"
"Message history" ▶: See chapter "Ventilation", "Message history".

"Solar"

"Collector temperature"
"DHW temp. solar"
"Return temp. solar"
"Solar circuit pump" (hours run)
"Solar energy bar chart"
"Solar energy"
"Solar circuit pump" (status)
"Solar circuit pump" (pump rate in %)
"Reheat suppression"
"Sol. output 22"
"Solar sensor 7"
"Solar sensor 10"

Diagnosis (service scans) (cont.)

"Heat pump"

"Compressor"/"Compressor 1"
"Compressor 2"
"Primary source 1" (status)
"Primary source 1" (output in %)
"Fan" (status)
"Fan" (rating in %)
"Alternative source"
"Disch. coolant buffer"
"Secondary pump" (status)
"Secondary pump" (pump rate in %)
"Valve heating/DHW"
"Hours run compressor"/"Hours run compressor 1" ▶
"No. of starts comprsr"/"No. of starts comprsr 1" ▶
"Refrig. circ reversal"
"Flow temp. primary"
"Return temp. primary"
"Evaporator temp."
"Flow temp. secondary"
"Return temp. sec."
"Inst.water heater st.1" (status)
"Inst.water heater st.1" ▶ (hours run)
"Inst.water heater st.2" (status)
"Inst.water heater st.2" ▶ (hours run)
"Runtime compressor" ▶: See chapter "Heat pump", "Compressor runtime".

"Refrigerant circuit"

"Refrigerant circuit controller" ▶: See chapters "Refrigerant circuit", "Refrigerant circuit controller [2]", "Refrigerant circuit controller [4]", "Refrigerant circuit controller [4-3] / [4-4]", "Refrigerant circuit controller [4-6] / [4-7]", "Refrigerant circuit controller [6]" or "Refrigerant circuit controller [7] / [7-1]".
"Compressor travel"/"Compressor travel 1" ▶: See chapters "Refrigerant circuit", "Compressor travel".
"Compressor travel 2" ▶: See chapters "Refrigerant circuit", "Compressor travel".
"Compressor path"/"Compressor path 1" ▶: See chapters "Refrigerant circuit", "Compressor path".
"Compressor path 2" ▶: See chapters "Refrigerant circuit", "Compressor path".
"Message history" ▶: See chapter "Refrigerant circuit", "Message history [2]", "Message history [4]", "Message history [4-3] / [4-4]", "Message history [4-6] / [4-7]", "Message history [6]" or "Message history [7] / [7-1]".

Diagnosis (service scans) (cont.)

"Energy statement"

"Energy statemnt heating" ▶
"Energy statement DHW" ▶
"Energy statem. cooling" ▶
"PV energy statemnt"
"SPF heating"
"SPF DHW"
"SPF cooling"
"SPF PV"
"SPF overall"

For further details, see chapter "Energy statement".

Note

The calculation function for the seasonal performance factor "SPF" is not integrated into all heat pumps.

"Photovoltaics"

"PV statistics" ▶: See chapter "Photovoltaics", "PV statistics".
"DHW loading statistics" ▶: See chapter "Photovoltaics", "DHW loading statistics".
"Output curves" ▶: See chapter "Photovoltaics", "Output curves".

Diagnosis (service scans) (cont.)

"Temperature sensors"	
"Outside temperature"	
"Evaporator temp."	
"Flow temp. primary"	
"Return temp. primary"	
"Flow temp. secondary"	
"Return temp. sec."	
"Hot gas temperature 1"	
"System flow temp"	
"Buffer outlet temp."	
"Htg wtr buffer cyl"	
"External heat source"	
"Boiler water temp."	
"Cylinder temp. top"	
"Cylinder temp. bottom"	
"Cylinder temp. centre"	
"DHW outlet temp."	
"Collector temperature"	
"DHW temp. solar"	
"Return temp. solar"	
"Flow temp. HC1"	
"Flow temperature HC2"	
"Flow temperature HC3"	
"Room temp. HC1"	
"Room temp. HC2"	
"Room temp. HC3"	
"Flow temp. cooling"	
"Room temp. SKK"	
"Coolant buffer temp."	
"Solar module sensor 7"	
"Solar module sensor10"	
"Common flow temperature"	
"Swimming pool flow t."	

Note

In the event of a fault, "- - -" appears on the display.

Diagnosis (service scans) (cont.)**"Signal inputs"**

"External demand"

"External blocking"

"Reheat suppression"

"Fault lag heat pump"

"Power-OFF contact"

"Three-phase monitor"

"Primary source"

"Safety high pressure"

"Low pressure"

"Control high pressure"

"Cmprsr motor protcn"

"Sw. pool heat demand"

"Demand htg mode HC1"

"Demand cool mode HC1"

"Demand htg mode HC2"

"Demand cool mode HC2"

"Demand htg mode HC3"

"Demand cool mode HC3"

"Brief scan": See chapter "Brief scan".**"System information"**: See chapter "System information".**System overview****1. Service menu:**

Press **OK** +  simultaneously and hold for approx. 4 s.

2. "Diagnosis"**3. "System overview"**

4.  to toggle between "System overview generator", "System overview consumer" and "System overview cascade"

Notes

- *The display is dependent upon the system version.*
- *The symbols on the display are animated if the components are operational (e.g. pumps).*
- *The values shown are examples.*

System overview (cont.)

System overview generators

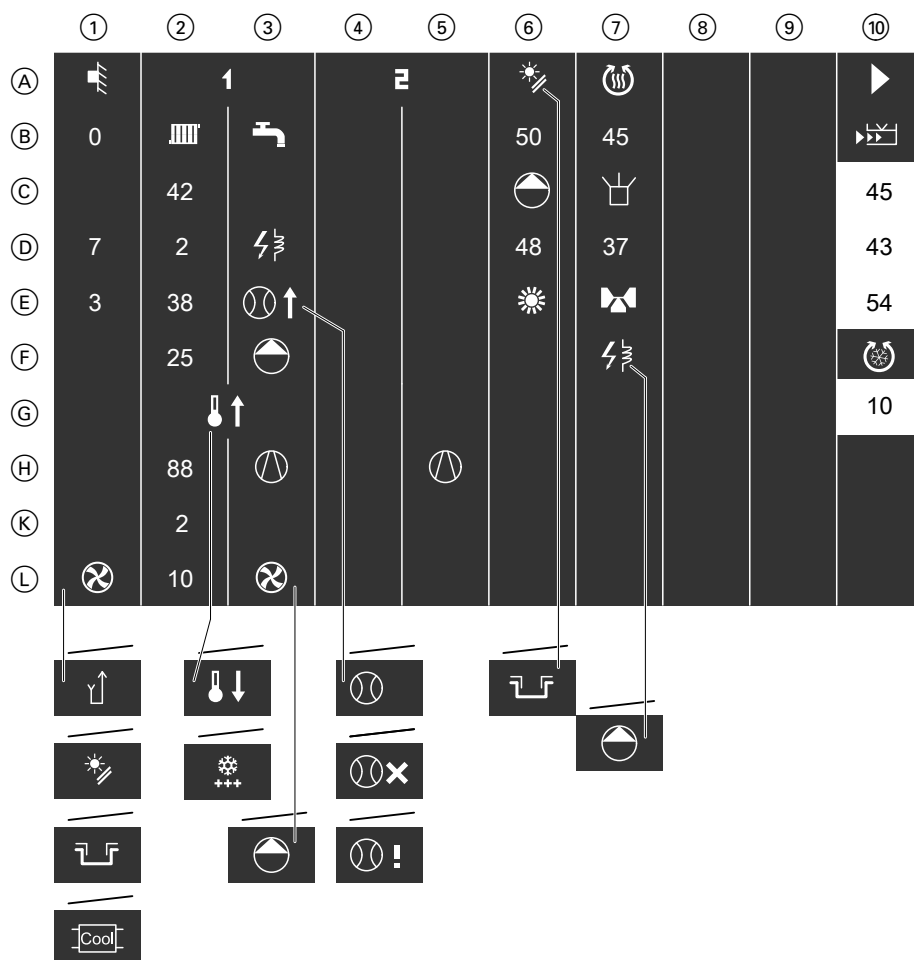

Fig. 15 Set temperatures are highlighted white.

① to ⑩, (A) to (L):
For the meaning of the symbols and values, see following tables.

System overview (cont.)

Meaning of the symbols and values

Column ①: Primary source

Line	Symbol/value			
Ⓐ		Outside temperature sensor		
Ⓑ	0	Adjusted outside temperature (long term average) in °C		
Ⓓ	7	Primary circuit flow temperature: Heat pump brine inlet temperature in °C	Air intake temperature in °C	
Ⓔ	3	Primary circuit return temperature: Heat pump brine outlet temperature in °C	Air outlet temperature in °C	
Ⓕ		—	Primary source, air	
		Primary source, brine	—	—
		Primary source, solar air absorber	—	—
		Primary source, ice store	—	—
		Primary source, coolant buffer cylinder	—	—

Column ②: Heat pump

Line	Symbol/value			
Ⓐ	1	Heat pump	Heat pump/compressor 1 with 2-stage refrigerant circuit	Heat pump
Ⓑ		Heating		
Ⓒ	42	Secondary circuit flow temperature		
Ⓓ	2	Stage of instantaneous heating water heater		
Ⓔ	38	Secondary circuit return temperature		
Ⓕ	25	Secondary pump output in %		
Ⓖ		Central heating		
		Central cooling		
		—	Defrost	
Ⓕ	88	For heat pumps with output control: Compressor frequency in Hz	Compressor output in %	Compressor frequency in Hz
Ⓖ	2	Evaporator temperature		
Ⓕ	10	Primary pump output in %	Fan rating in %	Fan speed in rpm

System overview (cont.)

Column ③: Heat pump

Line	Symbol/value			
Ⓐ	1	Heat pump	Heat pump/compressor 1 with 2-stage refrigerant circuit	Heat pump
Ⓑ		DHW heating		
Ⓓ		Instantaneous heating water heater		
Ⓔ	No symbol	No flow switch present in the secondary circuit.		
		<ul style="list-style-type: none"> Secondary circuit flow rate monitoring is switched off, e.g. when the compressor is switched off. 		
		<ul style="list-style-type: none"> Secondary circuit flow rate exceeds minimum flow rate: See heat pump specification. Heat pump specification Heat pump installation and service instructions		
		<ul style="list-style-type: none"> Secondary circuit flow rate falls below minimum flow rate: Message "Flow switch D6" appears. 		
		<ul style="list-style-type: none"> Flow switch in secondary circuit is faulty or jumper inserted at X3.3/X3.4 		
Ⓕ		Secondary pump		
Ⓖ		Compressor	Compressor/compressor 1 with 2-stage refrigerant circuit	Compressor
Ⓖ		—	Fan	—
		Primary pump	—	—

Column ⑤: Heat pump with 2-stage refrigerant circuit: Compressor 2

Row	Symbol/value			
Ⓐ	2	—	Compressor 2	—
Ⓖ		—	Compressor 2	—

Column ⑥: Solar thermal system or solar air absorber

Line	Symbol/value			
Ⓐ		Solar thermal system or solar air absorber		Solar thermal system
		Ice store	—	—
Ⓑ	50	Collector temperature or absorber temperature in °C		Collector temperature in °C
Ⓒ		Collector circuit pump or absorber circuit pump		Collector circuit pump
Ⓓ	48	Cylinder temperature (DHW cylinder) or ice store temperature in °C		Cylinder temperature (DHW cylinder) in °C
Ⓔ		Ice store summer mode	—	—

System overview (cont.)

Column ⑦: External heat generator

Line	Symbol/value			
Ⓐ		—	External heat generator	
Ⓑ	45	—	Boiler water temperature in °C	
Ⓒ		—	External heat generator demand	
Ⓓ	37	—	System flow temperature in °C	
Ⓔ		—	External heat generator mixer	
Ⓕ		—	Immersion heater in DHW cylinder	
		—	Circulation pump for cylinder reheating	

Column ⑩: Brief summary, consumer side

Line	Symbol/value			
Ⓐ			Continue to system overview, consumer side	
Ⓑ			Swimming pool heating demand (signal from temperature limiter for swimming pool temperature control)	
Ⓒ	45		Set buffer temperature in °C	
Ⓓ	43		Set system flow temperature in °C	
Ⓔ	54		Set cylinder flow temperature in °C	
Ⓕ			Cooling mode via heating/cooling circuit or separate cooling circuit	
Ⓖ	10		Set coolant buffer temperature in °C	

System overview (cont.)

System overview consumers

	⑪	⑫	⑬	⑭	⑮	⑯	⑰	⑱	⑳	
Ⓐ										
Ⓑ		54	45	21	21	21	19	14	65	
Ⓒ		50	43	20	20	20	21	13		
Ⓓ		47	43	38	38	38	15	13	170	30
Ⓔ			42	40	40	40	16	14	23	
Ⓕ		85	30						21	
Ⓖ									170	
Ⓕ			30						3	50
Ⓚ									96	100
Ⓛ										

Fig. 16 Set temperatures are highlighted white.

⑪ to ⑳, Ⓐ to Ⓛ:
 For the meaning of the symbols and values, see following tables.

System overview (cont.)

Meaning of the symbols and values

Column ⑪: Brief summary, generator side

Line	Symbol/value			
Ⓐ		Back to system overview, generator side		
Ⓑ		Heating with heat pump: Secondary pump on, 3-way diverter valve "Central heating/DHW heating" set to heating		
		DHW heating with heat pump/heat pump stage 1: Secondary pump on and 3-way diverter valve "central heating/DHW heating" set to DHW heating or circulation pump for cylinder heating ON		
Ⓒ		Compressor	Compressor/compressor 1 with 2-stage refrigerant circuit	Compressor
Ⓔ		—	Compressor 2 with 2-stage refrigerant circuit	—
Ⓕ		Instantaneous heating water heater, stage 1		
		Instantaneous heating water heater, stage 2		
		Instantaneous heating water heater, stage 3		
Ⓖ		Solar circuit pump		
Ⓗ		—	External heat generator demand	
Ⓚ		—	Immersion heater in DHW cylinder	
		—	Circulation pump for cylinder reheating	

Column ⑫: DHW heating

Line	Symbol/value			
Ⓐ		DHW heating		
Ⓑ	54	Set cylinder flow temperature in °C		
Ⓒ	50	Top cylinder temperature in °C		
Ⓓ	47	—	Bottom cylinder temperature in °C	
Ⓕ	85	—	Cylinder loading pump output in %	
Ⓖ		—	Cylinder loading pump	
Ⓗ		DHW circulation pump		

Column ⑬: Buffer cylinder/swimming pool

Line	Symbol/value			
Ⓐ		Heating water buffer cylinder or Heating water/coolant buffer cylinder		
Ⓑ	45	Set buffer temperature in °C		
Ⓒ	43	Buffer temperature in °C		
Ⓓ	43	Set system flow temperature in °C		
Ⓔ	42	System flow temperature in °C		
Ⓕ	30	—	Buffer outlet temperature (with heat pump cascade) in °C	
Ⓖ		Swimming pool heating		
Ⓗ	30	Swimming pool flow temperature (with heat pump cascade) in °C		
Ⓚ		Swimming pool heating demand (signal from temperature limiter for swimming pool temperature control)		
Ⓛ		Circulation pump for swimming pool heating		

System overview (cont.)

Column ⑭: Heating circuit without mixer A1/HC1

Line	Symbol/value	<input type="checkbox"/>	<input checked="" type="checkbox"/>	<input checked="" type="checkbox"/>
(A)	1	Heating circuit without mixer A1/HC1		
(B)	21	Set room temperature in °C		
(C)	20	Room temperature in °C		
(D)	38	Set flow temperature in °C		
(E)	40	Heating circuit flow temperature in °C		
(F)		Heating circuit pump		
(H)		Cooling via heating/cooling circuit		
		—	Active cooling function not enabled	

Column ⑮: Heating circuit with mixer M2/HC2

Line	Symbol/value	<input type="checkbox"/>	<input checked="" type="checkbox"/>	<input checked="" type="checkbox"/>
(A)	2	Heating circuit with mixer M2/HC2		
(B)	21	Set room temperature in °C		
(C)	20	Room temperature in °C		
(D)	38	Set flow temperature in °C		
(E)	40	Heating circuit flow temperature in °C		
(F)		Heating circuit pump		
(G)		Heating circuit mixer		
(H)		Cooling via heating/cooling circuit		
		—	Active cooling function not enabled	

Column ⑯: Heating circuit with mixer M3/HC3

Line	Symbol/value	<input type="checkbox"/>	<input checked="" type="checkbox"/>	<input checked="" type="checkbox"/>
(A)	3	Heating circuit with mixer M3/HC3		
(B)	21	Set room temperature in °C		
(C)	20	Room temperature in °C		
(D)	38	Set flow temperature in °C		
(E)	40	Heating circuit flow temperature in °C		
(F)		Heating circuit pump		
(G)		Heating circuit mixer		
(H)		Cooling via heating/cooling circuit		
		—	Active cooling function not enabled	

Column ⑰: Separate cooling circuit

Line	Symbol/value	<input type="checkbox"/>	<input checked="" type="checkbox"/>	<input checked="" type="checkbox"/>
(A)		Separate cooling circuit		
(B)	19	Set room temperature in °C		
(C)	21	Room temperature in °C		
(D)	15	Set flow temperature in °C		
(E)	16	Separate cooling circuit flow temperature in °C		
(F)		Cooling circuit pump	3-way diverter valve "Heating/cooling"	
(G)		Cooling circuit mixer		
(H)		Cooling via separate cooling circuit		
		—	Active cooling function not enabled	

System overview (cont.)

Column ⑱: Cooling

Line	Symbol/value	<input type="checkbox"/>	<input checked="" type="checkbox"/>	<input checked="" type="checkbox"/>
Ⓐ		Cooling		
Ⓑ	14	Set coolant buffer temperature in °C		
Ⓒ	13	Coolant buffer temperature in °C		
Ⓓ	13	Set cooling flow temperature in °C		
Ⓔ	14	Cooling flow temperature in °C		
Ⓕ		Cooling with coolant buffer cylinder		
Ⓖ		Natural cooling		
		—	Bypass, heating water buffer cylinder	
		—	Central heating with heating water/coolant buffer cylinder	
		—	Central cooling with heating water/coolant buffer cylinder	
Ⓗ		—	Active cooling with refrigerant circuit reversal or defrosting	

Column ⑲: Mechanical ventilation

Line	Symbol/value	<input type="checkbox"/>	<input checked="" type="checkbox"/>	<input checked="" type="checkbox"/>
Ⓐ		Mechanical ventilation with connected ventilation unit		
Ⓑ	65	Preheating coil output in %		
Ⓒ		Passive heating		
		Passive cooling		
Ⓓ	170	Set supply air flow rate in m³/h		
Ⓔ	23	Supply air temperature in °C		
Ⓕ	21	Extract air temperature in °C		
Ⓖ	170	Set exhaust air flow rate in m³/h		
Ⓗ	3	Exhaust air temperature in °C		
Ⓚ	96	Heat recovery level in %		

Column ⑳: External functions

Row	Symbol/value	<input type="checkbox"/>	<input checked="" type="checkbox"/>	<input checked="" type="checkbox"/>
Ⓐ		External demand, external blocking, external switching of operating status		
Ⓓ	30	Set secondary circuit flow temperature for all external heating circuit control units in °C		
Ⓖ		External demand active		
		External blocking active		
		Operating status, external changeover		
Ⓗ	50	Secondary circuit set flow temperature with external demand in °C: See chapter "External functions".		
Ⓚ	100	Requested heating output in %		

System overview (cont.)

System overview for cascade /

(A)	m	1	2	3	4
(B)					
(C)	46 41	42 37	39 34	45 40	48 43
(D)	3	1	2	1	3
(E)	56	57	57	43	59
(F)	57	55	58	0	57
(G)	3412	2410	2311	2619	2146
(H)					
(K)					
(L)					

Fig. 17 Set temperatures are highlighted white.

(A) to (L):

For the meaning of the symbols and values, see following table.

Meaning of the symbols and values

The indicated information is identical for all columns.

Line	Symbol/value		
(A)		"Manual mode" is set (see "Vitotronic 200" operating instructions). The heat pump is not available for operation in the heat pump cascade.	
	m	Lead heat pump	
	1 to 4	Lag heat pump 1 to lag heat pump 4 in line with "Number of heat pump in cascade 7707": If no runtime balancing has been set, the lag heat pumps are started consecutively in ascending number order.	
	to	The lag heat pump is present, but cannot be started on demand, e.g. in the event of a fault.	
		There are fault messages for the heat pump. For calling up messages on the relevant heat pump control unit: See chapter "Messages".	
(B)		Central heating	
		DHW heating	
(C)	46 (value on left)	Secondary circuit flow temperature in °C	
	41 (value on right)	Secondary circuit return temperature in °C	
(D)	1 to 3	Stage of instantaneous heating water heater	
		Instantaneous heating water heater (connected to the heat pump control system)	
(E)	56	Set compressor output in %	Set compressor frequency in Hz
		Central heating	
		Central cooling	
		Defrost	

System overview (cont.)

Line	Symbol/value	⊗	⊗□
Ⓕ	57	Compressor output in %	Compressor frequency in Hz
	⚠	Compressor	
Ⓖ	3412	Runtime of compressor in h	

System

Timer

The "Timer" display shows events that end after expiry of the time displayed. The entire duration of these events is specified by parameters.

- Service menu:**
Press **OK** + simultaneously and hold for approx. 4 s.
- "Diagnosis"**
- "System"**
- "Timer"**

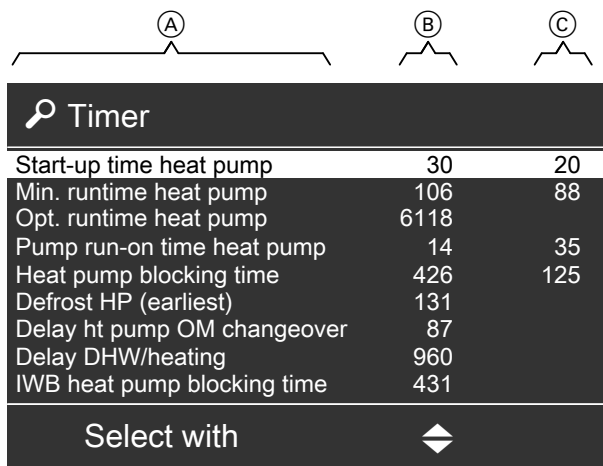

Fig. 18

- Ⓐ Active events
- Ⓑ Remaining time in s

Active events	Meaning	Factory-set times
"Start-up time heat pump"	Advance runtime for fan and secondary pump	60 or 120 s
"Min. runtime heat pump"	Minimum runtime for increasing heat pump efficiency	30, 180 or 360 s
"Opt. runtime heat pump"	⊗: 20 min after the end of the last defrosting event ⊗□ / □ Timespan during which the heat pump must operate fault-free, before the fault counter inside the control unit is reset.	10 or 20 min
"Min. start time HP"	With 2-stage refrigerant circuit: Min. time until a compressor may restart.	20 min
"Pump run-on time heat pump"	Secondary pump run-on time, after which central heating or DHW heating with the heat pump ends.	120 s
"Heat pump blocking time"	Pause to reduce compressor wear	180 or 600 s
"Defrost HP (earliest)"	For defrosting by refrigerant circuit reversal: <ul style="list-style-type: none"> ▪ During the defrost process: Remaining defrost time or ▪ After the defrost process has ended: Blocking time before the next defrosting 	<ul style="list-style-type: none"> ▪ Vitocal 100-S/111-S: No value specified ▪ Vitocal 200-A/200-S/222-A/222-S: 30 min ▪ Vitocal 300-A, type AWO 302.B: 60 to 75 min

System (cont.)

Active events	Meaning	Factory-set times
"Defrost HP (latest)"	For defrosting by refrigerant circuit reversal: If the evaporation temperature falls below the specified defrost threshold, the next defrost process begins at the latest when the duration shown has expired.	60 or 240 min
"Natural defrosting"	Remaining duration for defrosting with ambient air: This is where the fan channels warm ambient air over the evaporator. No heat is extracted from the secondary circuit. The compressor does not run.	60 min
"Delay ht pump OM change-over"	Compressor runtime extension after changeover from DHW heating to central heating	120 s
"Refrigerant circuit functions"	Max. time for suction gas pressure control	10 min
"HP protection functions"	<ul style="list-style-type: none"> ▪ Max. time during which the minimum temperature differential between condenser and evaporator does not have to be reached. ▪ For refrigerant circuit reversal: Max. time during which the evaporation temperature may be below 0 °C. 	10 min
"Delay DHW/heating"	<ul style="list-style-type: none"> ▪ Max. duration of DHW heating if there is a heat demand from the heating circuits. or ▪ Max. duration of central heating if there is a heat demand from the DHW cylinder. 	"Max. runtime DHW heating in heating mode 6011"
"IWB heat pump blocking time"	During this time, no integrals are built for start thresholds	0.5 x "Start delay instantaneous heating water heater 7905"
"IWB elec. heater blocking time"		"Start delay instantaneous heating water heater 7905"
"IWB ext. HS blocking time"		"Start delay external heat source 7B04"
"External heat source"	External heat generator minimum runtime	20 min
	External heat generator minimum runtime without heat demand	10 min
"Events"	With 2-stage refrigerant circuit: Time, until the other compressor may be switched on.	20 min

Note

- The times specified depend in part on the heat pump type.
- Some specified times can only be changed by a heat pump installer certified by Viessmann.

Integrals

Some system components are only started when the relevant temperature limit is undershot or exceeded if the start integral has also exceeded the associated start threshold, e.g. "**Start threshold 730E**". The start integral is calculated from the level and duration of the limit excess or shortfall.

Condition: Heating/cooling demand is low.

The heat pump control unit calculates various integrals.

1. Service menu:

Press and hold **OK** + **≡**: simultaneously for approx. 4 s.

2. "Diagnosis"

System (cont.)

- 3. "System"
- 4. "Integral"

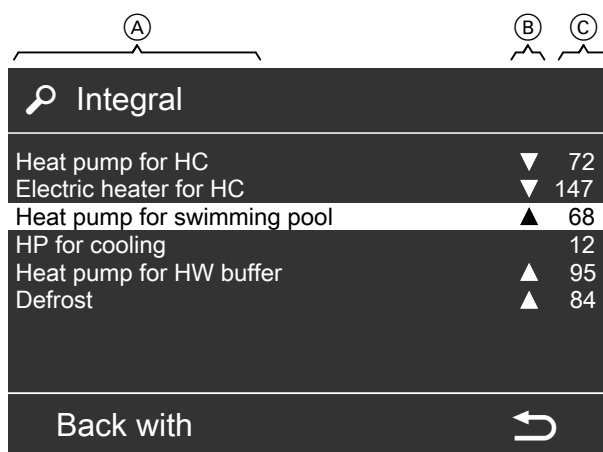

Fig. 19

- Ⓐ Integral
- Ⓑ Condition of the integral
 - ▲ The integral increases.
 - ▼ The integral reduces.
 - No symbol: Integral does not change.
- Ⓒ Current value of the integral in %, relative to the associated start threshold/output default

Integral	Meaning	Factory-set start threshold/ output default
"Heat pump for DHW"	Starting the heat pump for DHW heating	Output-dependent controlled heat pumps: ▪ Output default from the curve Heat pumps without output control: ▪ 0 or 100 %
"Electric heater for DHW"	Switching on the instantaneous heating water heater and/or the immersion heater for DHW reheating	—
"Ext. HS for DHW"	Switching on the external heat generator for DHW reheating	—
"Heat pump for HC"	Starting the heat pump for central heating	"Start threshold 730E"
"Electric heater for HC"	Starting the instantaneous heating water heater for central heating	
"Ext. HS for HC"	Starting the external heat generator for central heating	"Start threshold external heat source 7B03"

System (cont.)

Integral	Meaning	Factory-set start threshold/ output default
"Heat pump for swimming pool"	Starting the heat pump for swimming pool heating	"Start threshold 730E"
"HP for cooling"	Starting the heat pump in the case of weather-compensated central cooling with active cooling	
"Heat pump for HW buffer"	Starting the heat pump for buffer heating	
"Defrost"	Defrost integral	<ul style="list-style-type: none"> ▪ In the case of min. return temperature secondary circuit: 10 or 35 K·min ▪ In the case of max. return temperature secondary circuit: 40 or 70 K·min
"Coolant buffer temp."	Starting the heat pump for cooling the heating water/coolant buffer cylinder	"Start threshold 730E"

Note

- Values of start threshold/output defaults depend in part on the heat pump type.
- Some settings can only be changed by a heat pump installer certified by Viessmann.

Logbook

The logbook contains the last 30 status changes of components of the heating system and the heat pump. To analyse the control characteristics of the heat pump control unit, additional information for each entry can be called up, such as time and reason for the status change.

1. **Service menu:**
Press **OK** +  simultaneously and hold for approx. 4 s.
2. **"Diagnosis"**
3. **"System"**
4. **"Logbook"**
5. Select entry. Display further information with **OK**.

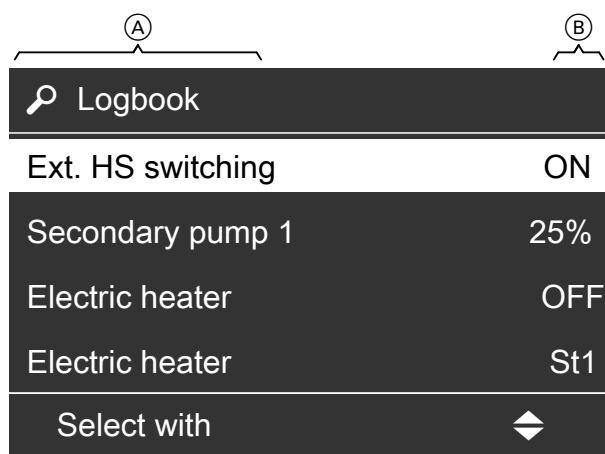

Fig. 20

- (A) Component whose status has changed.
- (B) Set status

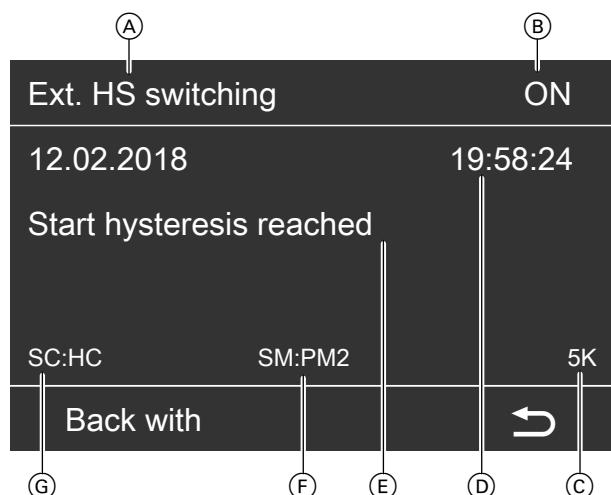

Fig. 21

- Ⓐ Component whose status has changed.
- Ⓑ Set status
- Ⓒ Preset condition or limit for the status change with unit
- Ⓓ Date and time of the status change
- Ⓔ Event (reason for the status change)
- Ⓕ State machine "SM": Control circuit that has triggered the status change.
- Ⓖ "SC": Hydraulic circuit to which the status change relates.

Component Ⓐ and set status Ⓑ

Component Ⓐ	Meaning	Set status Ⓑ	
		With output control	Without output control
"Compressor 1"	Compressor or compressor 1 with 2-stage refrigerant circuit	"0 %" to "100 %"	—
"Compressor 2"	Compressor 2 with 2-stage refrigerant circuit		
"Primary source 1"	☐: Primary pump ⊗☐ / ⊗: Fan or inverter frequency		
"Secondary pump 1"	Secondary pump		
"Electric heater"	Instantaneous heating water heater	"OFF", "St1", "St2", "St3" to indicate the selected stage	—
"LPG solenoid valve 1"	Shut-off valve in the refrigerant circuit	—	"ON" or "OFF"
"Cylinder reheating"	Circulation pump for cylinder reheating or immersion heater		
"Ext. HS switching"	Switch on external heat generator		
"Active cooling"	Active cooling function		

System (cont.)

Component ^(A)	Meaning	Set status ^(B)	
		With output control	Without output control
"Heating circ pump HC1"	Heating circuit pump heating circuit A1/HC1	—	"ON" or "OFF"
"Heating circ pump HC2"	Heating circuit pump heating circuit M2/HC2		
"Heating circ pump HC3"	Heating circuit pump heating circuit M3/HC3		
"Sw. outp. DHW circ p."	DHW circulation pump	—	"ON" or "OFF"
"Central fault message"	Central fault message		
"Natural cooling"	Natural cooling function		
"Valve heating/DHW1"	3-way diverter valve "Central heating/DHW heating"	—	"ON" or "OFF"
"Cylinder primary pump"	Cylinder loading pump		
"Swimming pool valve"	3-way diverter valve for "swimming pool heating"		
"Lag heat pump 1"	Lag heat pump 1	—	"ON" or "OFF"
"Lag heat pump 2"	Lag heat pump 2		
"Lag heat pump 3"	Lag heat pump 3		
"Lag heat pump 4"	Lag heat pump 4		
"Refrig. circ reversal"	Defrosting by refrigerant circuit reversal		
"Methods"	Several system components simultaneously		

Note

- Only one event is indicated for each status change.
- If a status change depends on several interlinked events, it is always the last event that is indicated.

Events ^(E)

Event ^(E)	Causes
"Start hysteresis reached"	Set temperature exceeded or undershot by hysteresis.
"Stop hysteresis reached"	Set temperature exceeded or undershot by hysteresis.
"OM changeover acc. to time program"	Change to the operating status according to the set time program
"OM changeover ext. hook-up"	Change to the operating status via external devices, digital input, BMS, lead heat pump, etc.
"Set value jump"	Change to the secondary circuit set flow temperature, e.g. due to the following conditions: <ul style="list-style-type: none"> ▪ Operating status changed according to the set time program. ▪ Changeover between central heating, DHW heating, central cooling or swimming pool heating ▪ Function "Demand externally" or "Block externally" is active.
"Set value reached"	Cylinder temperature or buffer temperature has reached the set or max. temperature.
"Hydr. circuit changeover"	Changeover between central heating, DHW heating, central cooling or swimming pool heating
"Start/stop optimisation active"	Function "Start optimisation for DHW heating 6009" or "Stop optimisation for DHW heating 600A" active
"Power-OFF enabled"	Power-OFF is active.

System (cont.)

Event [Ⓔ]	Causes
"Compressor stop"	<ul style="list-style-type: none"> ▪ Compressor has stopped. There is no longer a demand. or ▪ A fault has occurred.
"Integral value reached"	Integral for starting a component, a function or an operating stage has exceeded the start threshold.
"Integral value undershot"	Integral for starting a component, a function or an operating stage has undershot the start threshold.
"Alternative heating"	Should the compressor be unable to start, an external heat generator, instantaneous heating water heater or immersion heater will be started.
"Pump run-on"	Run-on time of a circulation pump active, e.g. secondary pump after the compressor has shut down
"High demand"	Demand " High " or " Maximum " for control circuit is active.
"Demand externally"	"Demand externally" function is active.
"Block externally"	"Block externally" function is active.
"Natural defrosting"	Defrosting with ambient air: Refrigerant circuit is not operational.
"Output at zero"	No more demand for the heat source.
"EEV shutdown"	Operating point outside application limits or refrigerant circuit controller fault (see " Diagnosis " ► " Refrigerant circuit " ► " Message history ")
"Refrigerant circuit fault"	Temperature at the condenser too low on several occasions; observe message " AC Compressor shutdown ".
"Frost protection"	<ul style="list-style-type: none"> ▪ Temperature at the condenser too low ▪ Temperature inside the DHW cylinder too low
"Safety chain"	Safety chain interrupted
"Primary temperature outside application limits"	Flow temperature primary circuit or air intake temperature outside the control limits; observe " CB Flow temp. primary " message.
"Timer expired"	Active timer has expired, e.g. " Start-up time heat pump ": See chapter "Timer".
"Max. value exceeded"	Max. hot gas temperature or max. high pressure condenser exceeded.
"Output demand"	Production manager issued demand to heat source, e.g. heat pump, external heat generator, etc.
"Max. temperature in secondary circuit exceeded"	Max. flow temperature in secondary circuit has been exceeded
"Flow switch"	<ul style="list-style-type: none"> ▪ Flow switch has responded. or ▪ No jumper installed.
"Defrost"	☒ / ☒: Defrosting by refrigerant circuit reversal
"Mains protection"	Instantaneous heating water heater is stopped immediately before the compressor starts.
"Limit pressure"	Min. suction gas pressure undershot.
"Temperature rise"	Max. temperature differential between evaporator and condenser exceeded or min. temperature differential between evaporator and condenser undershot.
"Contact humidistat"	Contact humidistat has responded.
"Min. temperature in secondary circuit undershot"	Min. secondary circuit flow temperature undershot

State machines "SM" [Ⓕ]

State machines indicate the status of control circuits in the heat pump control unit. This enables the functions of individual heat pump and heating system components to be traced.

System (cont.)**Consumers**

Display	Control circuit
"HC1"	Heating circuit A1/HC1 (" Heating circuit 1 ")
"HC2"	Heating circuit M2/HC2 (" Heating circuit 2 ")
"HC3"	Heating circuit M3/HC3 (" Heating circuit 3 ")
"CC"	Separate cooling circuit (" Cooling circuit ")
"BC"	" Heating water buffer cylinder "
"DHW"	DHW heating (" DHW cylinder ")
"HCFDM"	" Heating circuit load manager "

Local demand managers

Display	Control circuit
"LFDM1"	DHW heating (" Local demand manager DHW ")
"LFDM2"	Heating circuits (" Local demand manager HC ")
"LFDM3"	Cooling " Local demand manager cooling "
"LFDM4"	Swimming pool heating (" Local demand manager pool ")

Central demand managers

Display	Control circuit
"CFDM1"	DHW heating (" Central demand manager DHW ")
"CFDM2"	Heating circuits (" Central demand manager HC ")
"CFDM3"	Cooling " Central demand manager cool. "
"CFDM4"	Swimming pool heating (" Central demand manager pool ")

Production managers

Display	Control circuit
"PM1"	DHW heating (" Production manager DHW ")
"PM2"	Heating circuits (" Production manager HC ")
"PM3"	Cooling (" Production manager cooling ")
"PM4"	Swimming pool heating (" Production manager pool ")

Heat sources

Display	Control circuit
"HP1"	Heat pump, compressor 1 with 2-stage refrigerant circuit (" Heat pump 1 ")
"HP2"	Compressor 2 with 2-stage refrigerant circuit (" Heat pump 2 ")
"EHE"	Immersion heater (" Electr booster heater ")
"EHEIZ"	Instantaneous heating water heater (" Electr booster heater ")
"EXHS"	External heat generator (" External heat source ")
"LagHP1"	Lag heat pump 1 (" Lag heat pump 1 ")
"LagHP2"	Lag heat pump 2 (" Lag heat pump 2 ")
"LagHP3"	Lag heat pump 3 (" Lag heat pump 3 ")
"LagHP4"	Lag heat pump 4 (" Lag heat pump 4 ")
"BRINE CIRC"	Primary circuit (" Geothermal probe ")

Hydraulic circuit "SC" ⑥

Display	Hydraulic circuit
"DHW"	DHW heating
"HC"	Heating circuit A1/HC1, heating circuit M2/HC2, heating circuit M3/HC3
"COOL"	Separate cooling circuit
"POOL"	Swimming pool

Ventilation

Ventilation: Overview

Function scheme for mechanical ventilation with connected ventilation unit

The following information can be called up:

- Temperatures and set air flow rates
- Operating conditions and data for fans and other components
- Values captured by connected sensors

1. Service menu:

Press **OK** + **≡**: simultaneously and hold for approx. 4 s.

2. "Diagnosis"

3. "Ventilation"

4. "Ventilation: Overview"

Notes

- For some ventilation units, **not all** symbols and values shown are displayed.
- Only components installed in the mechanical ventilation system are shown, e.g. electric preheating coil.
- The symbols on the display are animated if the fans or other ventilation unit components are operational.
- The values shown are examples.

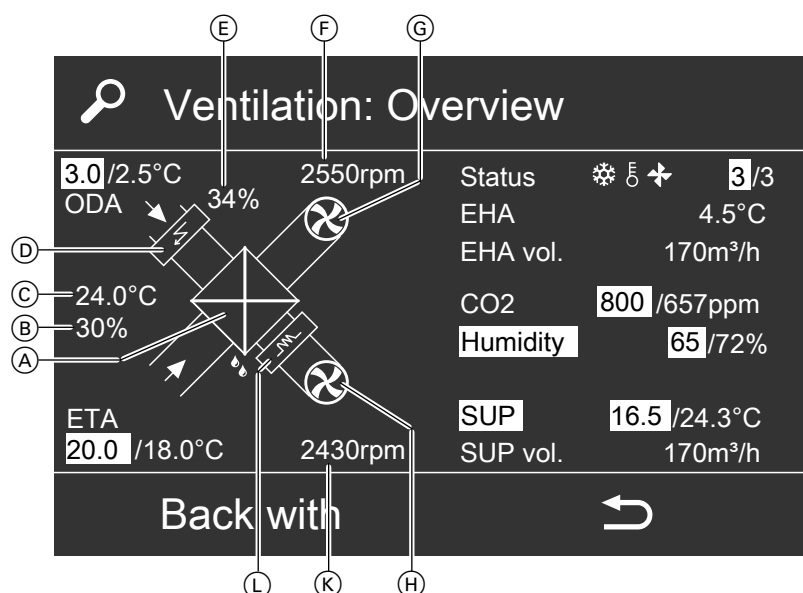
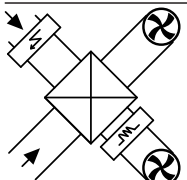
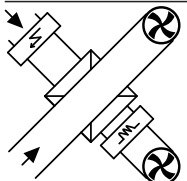
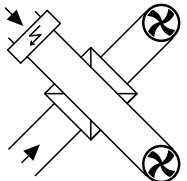

Fig. 22

- ① Heat exchanger
- ② Vitovent 200-C/200-W/300-C/300-W: Opening of the bypass damper in %
- ③ Vitovent 200-W/300-C/300-F/300-W: Outdoor air temperature, measurement downstream of electric preheating coil (accessories)
- ④ Electric preheating coil (accessories)
- ⑤ Current heating output of the electric preheating coil in %
- ⑥ Speed, exhaust air fan
- ⑦ Exhaust air fan
- ⑧ Supply air fan
- ⑨ Speed, supply air fan
- ⑩ Vitovent 300-F: Hydraulic reheating coil
- ⑪ Vitovent 200-C: Symbol flashes: Defrost of heat exchanger active

Ventilation (cont.)

Meaning of values and symbols

Display	Meaning	Vitovent			
		200-C	300-F	200-W 300-C 300-W	
	Bypass not active : Outdoor air is routed via heat exchanger.	X	X	X	
	Bypass active (passive heating/cooling): Extract air is not routed via the heat exchanger.	—	X	X	
	Bypass active (passive heating/cooling or defrost/frost protection function): Outdoor air is not or only partially routed via the heat exchanger.	X	—	—	
"ODA"	3.0	Set temperature in °C for control of electric preheating coil in conjunction with frost protection comfort function	X	—	—
	2.5	Outdoor air temperature in °C, measurement downstream of electric preheating coil (accessories) Outdoor air temperature for Vitovent 300-F See pos. © in Fig. 22.	X	—	X
"Status"	☼	Frost protection function active, with or without electric preheating coil	X	X	X
	⊖	Icing up of heat exchanger due to inadequate supply air temperature recognised	X	—	200-W
	✦	Icing up of heat exchanger due to excessive fan speed recognised	X	—	300-C 300-W
	3	Set ventilation level	X	X	X
	3	Currently active ventilation level	X	X	X
"EHA"	4.5	Exhaust air temperature in °C	—	X	—
"EHA vol."	170	Exhaust air flow rate in m ³ /h	X	X	X
"CO₂" Highlighted white: CO ₂ concentration is crucial for air flow rate adjustment. (CO ₂ /humidity sensor required; accessories)	800	"CO₂ value for raising the flow rate 7D18" CO ₂ concentration in ppm ("parts per million"), above which the air flow rate will be adjusted.	—	X	—
	657	Actual CO ₂ concentration in ppm	—	X	—
"Humidity" Highlighted white: Relative humidity is crucial for air flow rate adjustment. (CO ₂ /humidity sensor required; accessories)	65	"Humidity value for raising the flow rate 7D19" Relative humidity in %, above which the air flow rate will be adjusted.	—	X	—
	72	Actual relative humidity in %			
		<ul style="list-style-type: none"> ▪ Measurement with CO₂/humidity sensor ▪ Measurement with central humidity sensor 	—	X	—
			—	—	X

Ventilation (cont.)

Display		Meaning	Vitovent		
			200-C	300-F	200-W 300-C 300-W
"SUP" Highlighted white: Differential between the supply air temperature and the set value is crucial for air flow rate adjustment.	16.5	Set supply air temperature in °C ■ Vitovent 200-C: Shown only in relation to frost protection with electric preheating coil: Set temperature for controlling the output of the electric preheating coil during defrosting via bypass ■ Vitovent 300-F: For ventilation heating circuit: Set flow temperature, heating circuit A1/HC1 + 5 K	X	X	—
	24.3	Actual supply air temperature in °C, captured downstream of the reheating coil (accessories)	X	X	—
"SUP vol."	170	Supply air flow rate in m ³ /h	X	X	X
"ETA"	20.0	"Set room temperature 7D08"	X	X	—
		"Set room temperature C108"	—	—	X
	18.0	Actual extract air temperature in °C	X	X	X

Ventilation

1. **Service menu:**
Press and hold **OK** +  simultaneously for approx. 4 s.
2. **"Diagnosis"**
3. **"Ventilation"**
4. **"Ventilation"**

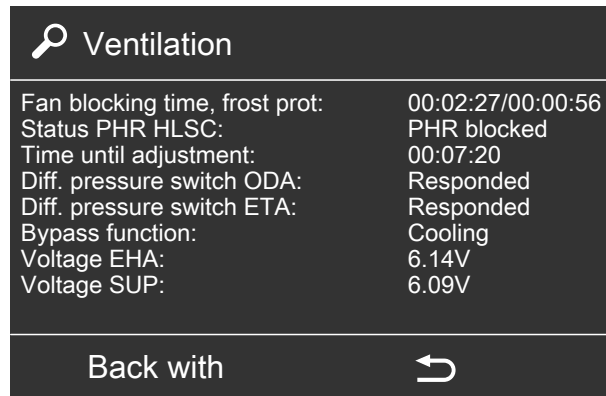

Fig. 23

Ventilation (cont.)

Display	Meaning	Vitovent		
		200-C	300-F	200-W 300-C 300-W
"Fan blocking time, frost prot:"	<ul style="list-style-type: none"> ▪ If one or both fans have been switched off for frost protection: Remaining duration until the fans are started again ▪ If the frost protection function of the ventilation unit is active and the fans are switched on: Min. duration after which the fans can be stopped for frost protection. <p>If 2 time periods are displayed:</p> <ul style="list-style-type: none"> ▪ Left hand time period: Frost protection function was switched on due to the outdoor air temperature being too low. ▪ Right hand time period: Frost protection function was switched on due to the supply air temperature being too low. <p>Note <i>If both time periods are shown, both the outdoor air and supply air temperature are too low. The fans are only switched off and back on again when both time periods have expired.</i></p>	X	X	—
		—	X	—
"Status PHR HLSC:"	<p>"PHR blocked"</p> <p>High limit safety cut-out of the electric preheating coil (accessories) has responded. The electric preheating coil can only be restarted after the high limit safety cut-out has been reset with the "Reset" button on the preheating coil.</p> <p>Note <i>Remedy the cause of the fault before resetting the high limit safety cut-out: See "Vitovent 200-C" or "Vitovent 300-F" installation and service instructions.</i></p>	X	X	—
"Time until adjustment:"	<ul style="list-style-type: none"> ▪ Frost protection without electric preheating coil: Remaining time until the ventilation unit is switched back on in "Standard operation". ▪ Frost protection with electric preheating coil: Remaining time until adjustment of the ventilation level See chapter "Frost protection Vitovent 300-F". 	—	X	—
		<ul style="list-style-type: none"> ▪ If "Intensive operation" was switched on externally: Remaining time until "Intensive operation" ends automatically ("Duration, bathroom vent. 7D3B"). ▪ If the electric preheating coil is switched on: Remaining run-on time of fans, to prevent overheating of the electric preheating coil. 	X	—
"Blocking time for defrosting:"	Remaining time period until the next defrost process of the heat exchanger may start.	X	—	—
"Defrost time:"	Remaining duration of the currently active defrost function	X	—	—
"Detection, frost pr.max.speed:"	Icing up of heat exchanger was recognised due to excessive fan speed: Remaining time until defrost function becomes active.	X	—	—

Ventilation (cont.)

Display	Meaning	Vitovent		
		200-C	300-F	200-W 300-C 300-W
"Detection, frost pr.min. temp:"	Icing up of heat exchanger was recognised due to supply air temperature being too low: Remaining time until defrost function becomes active.	X	—	—
"Diff. pressure switch ODA:"	Status of differential pressure switch for outdoor air filter and/or extract air filter "Responded" Differential pressure has exceeded response value of differential pressure switch. The standard menu shows "Vent.: check filter(s)".	—	X	—
"Diff. pressure switch ETA:"	As for "Diff. pressure switch ODA:"	—	X	—
"Bypass function:"	"Ventilation" Bypass disabled	X	X	X
	"Cooling" Bypass active, passive cooling active	X	X	X
	"Heating" Bypass active, passive heating active	X	X	—
	"Passive de-frost" Defrost function for heat exchanger is active. Electric preheating coil is switched off.	X	—	—
	"Defrosting w PHR" Defrost function for heat exchanger is active. Electric preheating coil is switched on.	X	—	—
"Voltage EHA:"	Control voltage, exhaust air fan	X	X	X
"Voltage SUP:"	Control voltage, supply air fan	X	X	X

Message history Vitovent 200-C/300-F

Message history of the connected ventilation unit:

- Messages cannot be acknowledged in the message history.
- Messages are listed in chronological order. The most recent message is listed first.
- Up to 30 entries are stored.

1. Service menu:

Press and hold **OK** + **≡** simultaneously for approx. 4 s.

2. "Diagnosis"

3. "Ventilation"

4. "Message history"

Message overview

(A)	(B)	(C)	(D)	(E)
0	09.09.2009 17:16:00	06	Fault	7
1	09.09.2009 17:16:01	0A	Fault	3
2	09.09.2009 17:16:02	03	Note	11
3	09.09.2009 17:16:03	10	Fault	1

Back with

Fig. 24

- (A) Message number
- (B) Date and time of the last occurrence
- (C) 2-digit message code
- (D) Type of message: "Note", "Warning", "Fault"
- (E) Frequency of occurrence

Should a message occur at the ventilation unit, a message concerning the ventilation unit will also be displayed at the heat pump control unit. Which message will be displayed at the heat pump depends on the type of message at the ventilation unit: See "Message overview" for the heat pump control unit.

Ventilation (cont.)

Type of message at the ventilation unit	Message on the heat pump control unit
[H] "Note"	"0F Ventilation unit"
[W] "Warning"	"A0 Vent.: check filter(s)"
[S] "Fault"	"0E Ventilation unit"

Message code	Meaning	Ventilation unit characteristics	Measure
01	[W] Only Vitovent 300-F: Differential pressure has exceeded response value of one or both differential pressure switches.	Ventilation unit remains operational, increased electrical power consumption.	Replace outdoor air and extract air filters. Reset maintenance display.
02	[W]		
03	[W] Time interval for filter change has expired.		
05	[S] Short circuit/lead break, outdoor air temperature sensor	<ul style="list-style-type: none"> ▪ Vitovent 200-C: Ventilation unit is switched off. ▪ Vitovent 300-F: "Standard operation" is being activated. The value of the exhaust air temperature sensor minus 5 K is used. 	Check resistance value (NTC 10 kΩ) of ventilation unit sensor: See installation and service instructions for the ventilation unit.
06	[S] Short circuit/lead break, supply air temperature sensor		
07	[S] Short circuit/lead break, extract air temperature sensor	<ul style="list-style-type: none"> ▪ Vitovent 200-C: Ventilation unit is switched off. ▪ Vitovent 300-F: "Standard operation" is switched on. 	
08	[S] Only Vitovent 300-F: Short circuit/lead break, exhaust air temperature sensor	" Standard operation " is being activated. The value of the outdoor air temperature sensor is used.	
09	[S] Only Vitovent 300-F: CO ₂ signal capture disrupted	Ventilation unit remains operational, no regulation of the CO ₂ concentration.	Check CO ₂ /humidity sensor.
0A	[S] Only Vitovent 300-F: Humidity signal capture disrupted	Ventilation unit remains operational, no regulation of the humidity.	
0C	— Only Vitovent 300-F: Air humidity has exceeded the limit for raising the air flow rate.	Air flow rate is raised.	No action required
0D	— Only Vitovent 300-F: CO ₂ concentration has exceeded the limit for raising the air flow rate.		
0E	[H] " Standard operation " was activated due to another fault, e.g. sensor fault. Message does not occur on its own.	<ul style="list-style-type: none"> ▪ "Standard operation" is being activated. ▪ Bypass blocked. 	Measures according to the other messages

Ventilation (cont.)

Message code	Meaning	Ventilation unit characteristics	Measure
0F	<p>S</p> <p>Vitovent 200-C: Short circuit/lead break, outdoor air temperature sensor and/or extract air temperature sensor</p> <p>Vitovent 300-F: <ul style="list-style-type: none"> ▪ Short circuit/lead break, outdoor air temperature sensor and exhaust air temperature sensor ▪ Short circuit/lead break, supply air temperature sensor, if supply air heating is carried out via ventilation heating circuit </p>	Fans are switched off.	Check resistance value (NTC 10 kΩ) of ventilation unit sensor: See installation and service instructions for the ventilation unit.
10	<p>S</p> <p>High limit safety cut-out on electric preheating coil has responded.</p>	<ul style="list-style-type: none"> ▪ Vitovent 200-C: Defrost function without electric preheating coil is being used. ▪ Vitovent 300-F: Fans are switched off. 	<p>Check electric preheating coil. Replace preheating coil if necessary.</p> <ul style="list-style-type: none"> ▪ Vitovent 200-C: Replace thermal breakers. ▪ Vitovent 300-F: To restart, reset the high limit safety cut-out. Turn the ventilation unit off and back on again at the ON/OFF switch.
11	<p>H</p> <p>Only Vitovent 300-F: Frost protection for hydraulic reheating coil active</p>	The fans are switched off and switched back on again after a certain time.	<p>No action required:</p> <p>If the fault occurs several times, check bypass damper mechanically.</p>
14	<p>S</p> <p>Supply air fan blockage, fault or signal interruption</p>	<ul style="list-style-type: none"> ▪ Vitovent 200-C: Both fans are switched off, restart attempts at short intervals. ▪ Vitovent 300-F: Both fans remain off. 	<ul style="list-style-type: none"> ▪ Check fan for blockage or contamination. Remove blockage if required. Clean fan. ▪ Check fan electrical and power connections. ▪ Check fan is mechanically and electrically sound. ▪ Replace fan if required. ▪ Vitovent 300-F: Turn the ventilation unit off and back on again at the ON/OFF switch.
15	<p>S</p> <p>Exhaust air fan blockage, fault or signal interruption</p>		
FF	<p>S</p> <p>No communication with ventilation unit when heat pump control unit is switched on, e.g. if ventilation unit is not switched on or the wrong type is set at "Vitovent enable 7D00".</p>	<ul style="list-style-type: none"> ▪ Ventilation unit continues to run with the last set default values. or ▪ "Standard operation" is being activated. 	<ul style="list-style-type: none"> ▪ Switch ventilation unit on if required. ▪ Check ventilation unit and Modbus cable to heat pump. Replace the ventilation unit controller PCB if necessary. ▪ Check parameter setting "Vitovent enable 7D00". Correct setting if required. ▪ If present, observe message "EF Modbus subscriber" at heat pump control unit.

Ventilation (cont.)

Vitovent 200-W/300-C/300-W message history

Message history of the connected ventilation unit:

- Messages cannot be acknowledged in the message history.
- Messages are listed in chronological order. The most recent message is listed first.
- Up to 30 entries are stored.

1. Service menu:



Press **OK** +  simultaneously and hold for approx. 4 s.

2. "Diagnosis"

3. "Ventilation"

4. "Message history"

Should a message occur at the ventilation unit, a message concerning the ventilation unit will also be displayed at the heat pump control unit. Which message will be displayed at the heat pump depends on the type of message at the ventilation unit: See "Message overview" for the heat pump control unit.

Type of message at the ventilation unit	Message at the heat pump control unit
 "Note"	"0F Ventilation unit"
 "Warning"	"A0 Vent.: check filter(s)"
 "Fault"	"0E Ventilation unit"

Message overview

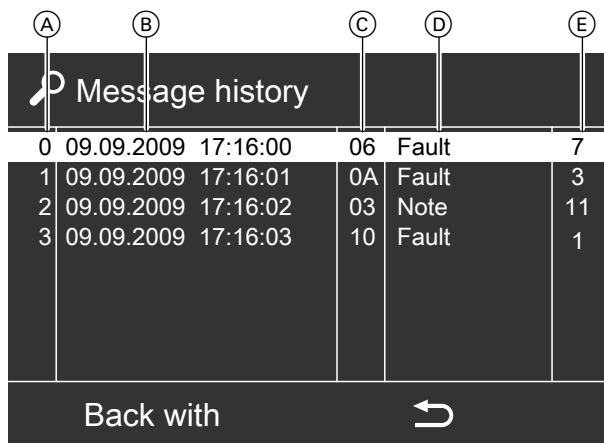

(A)	(B)	(C)	(D)	(E)
0	09.09.2009 17:16:00	06	Fault	7
1	09.09.2009 17:16:01	0A	Fault	3
2	09.09.2009 17:16:02	03	Note	11
3	09.09.2009 17:16:03	10	Fault	1



Back with 

Fig. 25

- (A) Message number
- (B) Date and time of the last occurrence
- (C) 2-digit message code
- (D) Type of message: "Note", "Warning", "Fault"
- (E) Frequency of occurrence

Message code	Meaning	Ventilation unit characteristics	Measure
03 	Time interval for filter change has expired.	Ventilation unit remains operational, increased electrical power consumption.	Clean outdoor air and extract air filters. In the event of severe contamination replace both filters at least once every 12 months. Reset service indicator.
04 	Short circuit/lead break, external temperature sensor (geothermal heat exchanger)	3-way diverter damper for geothermal heat exchanger (on-site provision) is not switched.	Check resistance value (NTC 10 kΩ) at connection X15.7/X15.8 on the controller PCB of the ventilation unit: See installation and service instructions for the ventilation unit.

Ventilation (cont.)

Message code	Meaning	Ventilation unit characteristics	Measure
05	[S] Short circuit/lead break, outdoor air temperature sensor	<ul style="list-style-type: none"> Both fans are stopped. The preheating coil is switched off. Bypass blocked. 	Check resistance value (NTC 10 kΩ) at connection X7.1/X7.2 on the controller PCB of the ventilation unit: See installation and service instructions for the ventilation unit.
07	[S] Short circuit/lead break, extract air temperature sensor	Bypass blocked.	Check resistance value (NTC 10 kΩ) at connection X17.1/X17.2 on the controller PCB of the ventilation unit: See installation and service instructions for the ventilation unit.
0A	[S] Signal reception from central humidity sensor interrupted	Ventilation unit remains operational, no regulation of the humidity level.	Check central humidity sensor. Isolate the ventilation unit from the power supply. Replace humidity sensor if required.
14	[S] Supply air fan blockage, fault or signal interruption	<ul style="list-style-type: none"> Both fans are stopped. Electric preheating coils are switched off. 	<ul style="list-style-type: none"> Check fan for blockage or contamination. Remove any blockages. Clean fan. Check fan electrical connections and connecting cable. Check fan is mechanically and electrically sound. Replace fan if required.
15	[S] Exhaust air fan blockage, fault or signal interruption		
1B	[S] Pressure sensor in the supply air fan faulty, or pressure hoses (red) blocked or kinked	<ul style="list-style-type: none"> Ventilation with a constant fan speed If the outdoor air temperature is < 0 °C, the factory-fitted electric preheating coil switches on. 	<ul style="list-style-type: none"> Check the pressure hoses (red) for contamination, kinks and damage: See installation and service instructions for the ventilation unit. Check the pressure sensor in the supply air fan. Replace fan if required.
1C	[S] Pressure sensor in the exhaust air fan faulty, pressure hoses (blue) blocked or kinked		<ul style="list-style-type: none"> Check the pressure hoses (blue) for contamination, kinks and damage: See installation and service instructions for the ventilation unit. Check the pressure sensor in the exhaust air fan. Replace fan if required.
FF	[S] No communication with ventilation unit when heat pump control unit is switched on, e.g. if ventilation unit is not switched on or the wrong type is set at "Vitovent enable 7D00" .	Ventilation unit continues to run with the last values specified.	<ul style="list-style-type: none"> Switch ventilation unit on if required. Check ventilation unit and Modbus cable to heat pump. Replace ventilation unit controller PCB if necessary. Check parameter setting "Vitovent enable 7D00". Correct setting if required. If present, observe message "EF Modbus subscriber" at heat pump control unit.

Heat pump

Compressor runtime

- Service menu:**
Press and hold **OK** +  simultaneously for approx. 4 s.

- "Diagnosis"**
- "Heat pump"**

Heat pump (cont.)

- 4. "Runtime compressor" for single-stage heat pump
- 5. Compressor hours run ("Runtime") can be scanned with **◀▶** for every "Load class".



Fig. 26

Load class assignment:

Load class	Hours run at $\Delta T_{V/K}$
1	$\Delta T_{V/K} < 25 \text{ K}$
2	$25 \text{ K} < \Delta T_{V/K} < 32 \text{ K}$
3	$32 \text{ K} < \Delta T_{V/K} < 41 \text{ K}$
4	$41 \text{ K} < \Delta T_{V/K} < 50 \text{ K}$
5	$\Delta T_{V/K} > 50 \text{ K}$

$\Delta T_{V/K}$ Differential between evaporation and condensation temperature

Refrigerant circuit

Note

- For assignment of refrigerant circuit controllers to heat pump types: See page 24.
- For further information on refrigerant circuit controllers: See page 183.

Refrigerant circ controller \otimes [2] / [6]

For heat pumps with an electronic expansion valve and refrigerant circuit controller **[2]** or **[6]**.

The following information can be called up:

- Refrigerant circuit temperature and pressure values
- Refrigerant circuit operating conditions

1. Service menu:

Press **OK** + **≡**; simultaneously and hold for approx. 4 s.

2. "Diagnosis"

3. "Refrigerant circuit"

4. "Refrigerant circ controller"

Notes

- For some heat pumps, **not** all symbols and values shown are displayed.
- The symbols on the display are animated if the components are operational (e.g. pumps).
- The values shown are examples.

Refrigerant circuit (cont.)

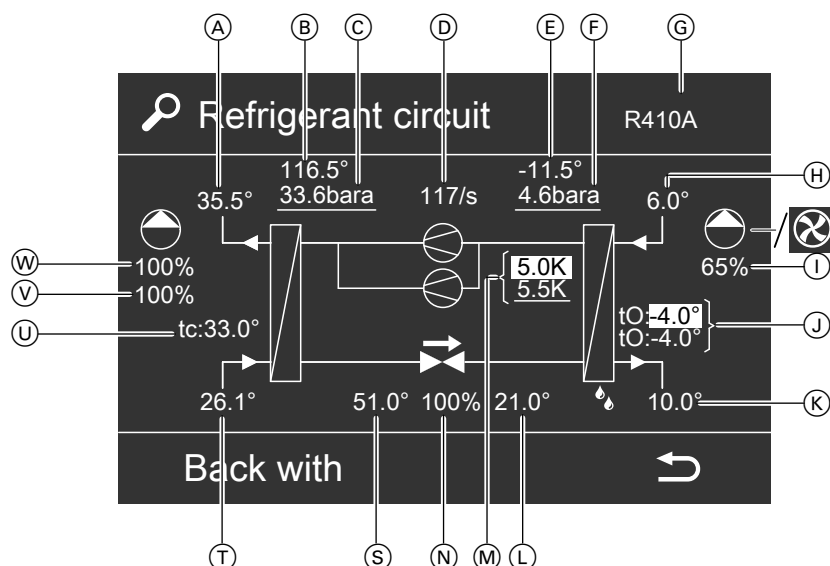

Fig. 27 2-stage refrigerant circuit in heating mode, heat generation at the condenser: Only 1 compressor is displayed with a single stage refrigerant circuit.

Pos.	Refrigerant circuit in heating mode	Refrigerant circuit reversal
	→ ↔	← ↔
(A)	Secondary circuit flow temperature in °C	
(B)	Hot gas temperature in °C	Suction gas temperature in °C
(C)	Hot gas pressure in bar(a) Value underlined: Hot gas control active [2]	Suction gas pressure in bar(a) Value underlined: Pressure control for suction gas active, max. operating pressure (MOP) of evaporator exceeded ([2]) or min. operating pressure of evaporator undershot (LOP, [2])
(D)	Compressor speed in rpm or in %	
(V)	Compressor <ul style="list-style-type: none"> ▪ Animated symbol: Compressor is running. ▪ When the refrigerant circuit is reversed the symbol appears turned by 180°. ▪ Only 1 symbol is displayed with a single stage refrigerant circuit. ▪ With a 2-stage refrigerant circuit, compressor 1 is at the top and compressor 2 at the bottom. 	
(E)	Suction gas temperature in °C	Hot gas temperature in °C
(F)	Suction gas pressure in bar(a) Value underlined: Pressure control for suction gas active, max. operating pressure (MOP) of evaporator exceeded ([2]) or min. operating pressure of evaporator undershot (LOP, [2])	Condensing pressure in bar(a) Value underlined: Hot gas control active [2]
(G)	Refrigerant	
(H)	Evaporator air intake temperature in °C	
(U)	Primary pump Animated symbol: Primary pump is running.	
(X)	Fan Animated symbol: Fan is running.	
(I)	Speed of fan or primary pump in %	

Refrigerant circuit (cont.)

Pos.	Refrigerant circuit in heating mode → ↔	Refrigerant circuit reversal ← ↔
ⓐ	Evaporation temperature in °C Value highlighted white: Set evaporation temperature in °C	Condensing temperature in °C
ⓑ	Air discharge temperature in °C	
Ⓒ	—	Symbol flashes: Defrost active
Ⓓ	—	Liquid gas temperature
Ⓜ	Suction gas superheating in K Value highlighted white: Set suction gas superheating in K Value underlined: Suction gas superheating control active	—
↔	Electronic expansion valve: → Refrigerant circuit in heating mode, heat generation at condenser	← (flashes) Refrigerant circuit reversal active (cooling mode/defrosting)
Ⓝ	Electronic expansion valve opening in %	
Ⓢ	Liquid gas temperature in °C	—
Ⓣ	Secondary circuit return temperature in °C	
Ⓤ	Condensing temperature in °C	Evaporation temperature in °C
Ⓥ	Speed, circulation pump for cylinder heating or cylinder loading pump in %	
Ⓦ	Secondary pump speed in %	
Ⓟ	Secondary pump, circulation pump for cylinder heating or cylinder loading pump Animated symbol: Pump is running.	

Refrigerant circ ctrlr [4]

Only for heat pumps with an electronic expansion valve and refrigerant circuit controller [4].

The following information can be called up:

- Refrigerant circuit temperature and pressure values
- Refrigerant circuit operating conditions

1. Service menu:

Press and hold **OK** + **≡**: simultaneously for approx. 4 s.

2. "Diagnosis"

3. "Refrigerant circuit"

4. "Refrigerant circuit controller"

Notes

- The symbols on the display are animated if the components are operational (e.g. pumps).
- The values shown are examples.

Refrigerant circuit (cont.)

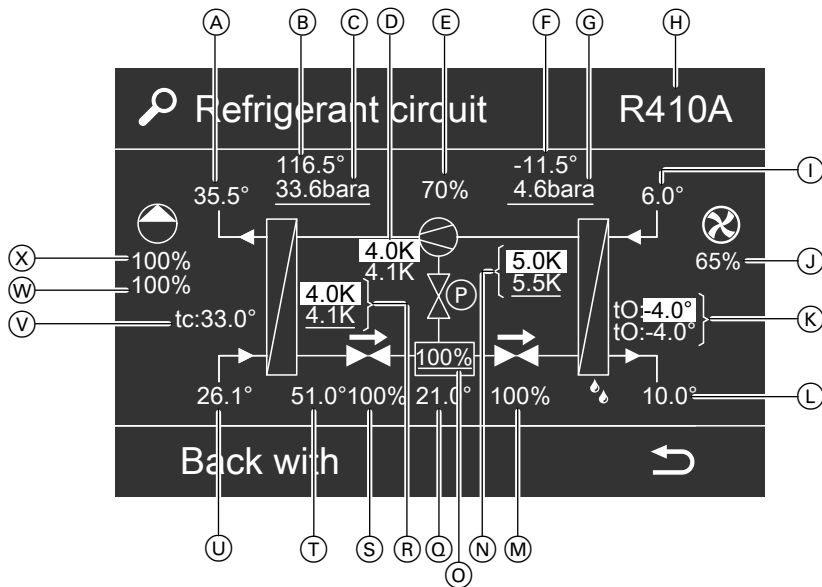

Fig. 28 Refrigerant circuit in heating mode, heat generation at condenser

Pos.	Refrigerant circuit in heating mode	Refrigerant circuit reversal
	→ ▶▶	← ◀◀
(A)	Secondary circuit flow temperature in °C	
(B)	Hot gas temperature in °C	Suction gas temperature in °C
(C)	Hot gas pressure in bar(a) Value underlined: Hot gas control active	Suction gas pressure in bar(a) Value underlined: Pressure control for suction gas active, max. operating pressure of evaporator (MOP) exceeded or min. operating pressure of evaporator (LOP) undershot
(D)	—	Suction gas superheating in K Value highlighted white: Suction gas superheating, set value in K Value underlined: Superheating control for suction gas active
(E)	Compressor output in %	
(F)	Compressor Animated symbol: Compressor is running. When the refrigerant circuit is reversed the symbol appears turned by 180°.	
(G)	Suction gas temperature in °C	Hot gas temperature in °C
(H)	Suction gas pressure in bar(a) Value underlined: Pressure control for suction gas active, max. operating pressure of evaporator (MOP) exceeded or min. operating pressure of evaporator (LOP) undershot	Condensing pressure in bar(a) Value underlined: Hot gas control active
(I)	Refrigerant	
(J)	Evaporator air intake temperature in °C	
(K)	Fan Animated symbol: Fan is running.	
(L)	Fan speed in %	

Refrigerant circuit (cont.)

Pos.	Refrigerant circuit in heating mode	Refrigerant circuit reversal
	→ ▶◀	← ▶◀
(K)	Evaporation temperature in °C Value highlighted white: Evaporation temperature, set value in °C	Condensing temperature in °C
(L)	Air discharge temperature in °C	
☉	—	Symbol flashes: Defrost active
▶◀	Electronic expansion valve for suction gas superheating (AHX): → Refrigerant circuit in heating mode, heat generation at condenser	← (flashes) Refrigerant circuit reversal active (cooling mode/defrosting)
(M)	Electronic expansion valve opening for suction gas superheating in %	
(N)	Suction gas superheating in K Value highlighted white: Suction gas superheating, set value in K Value underlined: Superheating control for suction gas active	—
(O)	Refrigerant collector level Value underlined: Fill level control active	
(P)	Intermediate injection solenoid valve	
(Q)	Refrigerant collector temperature	
(R)	Supercooling of the liquid gas in K Value highlighted white: LPG supercooling, set value in K Value underlined: Supercooling control for LPG active	—
▶◀	Electronic expansion valve for refrigerant collector level control (PHX): → Refrigerant circuit in heating mode, heat generation at condenser	← (flashes) Refrigerant circuit reversal active (cooling mode/defrosting)
(S)	Electronic expansion valve opening for refrigerant collector level control in %	
(T)	Liquid gas temperature in °C	
(U)	Secondary circuit return temperature in °C	
(V)	Condensing temperature in °C	Evaporation temperature in °C
(W)	Cylinder loading pump speed in %	
(X)	Speed of secondary pump or circulation pump for cylinder heating in %	
☉	Secondary pump or circulation pump for cylinder heating Animated symbol: Pump is running.	

Refrigerant circ controller ☉ [4-3]/[4-4]

The following information can be called up:

- Refrigerant circuit temperature and pressure values
- Refrigerant circuit operating conditions

1. Service menu:

Press and hold **OK** + **☰**: simultaneously for approx. 4 s.

2. "Diagnosis"

3. "Refrigerant circuit"

4. "Refrigerant circuit controller"

Notes

- The symbols on the display are animated if the components are operational (e.g. pumps).
- The values shown are examples.

Refrigerant circuit (cont.)

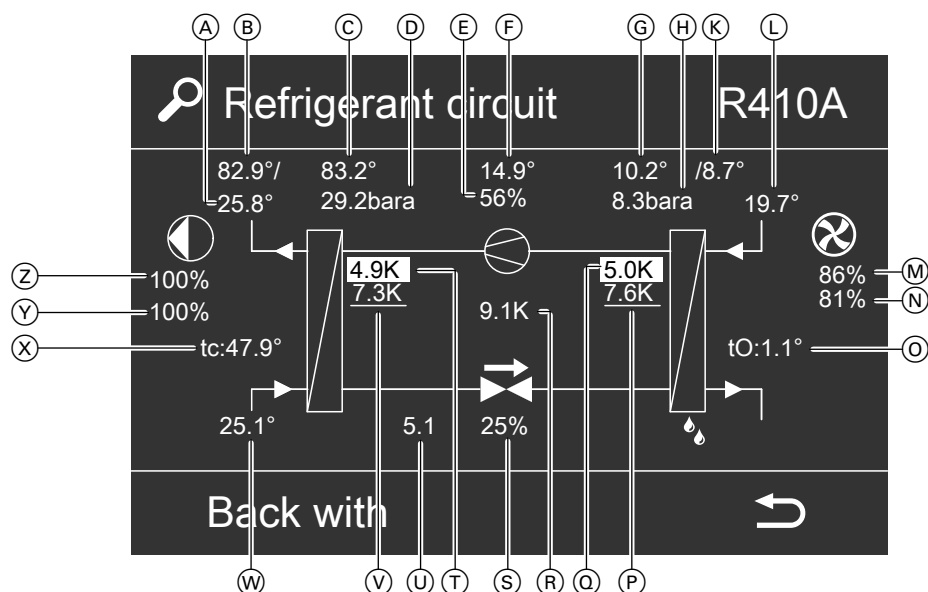

Fig. 29 Refrigerant circuit in heating mode, heat generation at condenser

Pos.	Refrigerant circuit in heating mode	Refrig. circ reversal
	→ ▶▶	← ◀◀
(A)	Secondary circuit flow temperature upstream of the	instantaneous heating water heater in °C
(B)	Hot gas temperature (upstream of condenser) in °C	Suction gas temperature in °C
(C)	Hot gas temperature (downstream of compressor) in °C	Suction gas temperature (upstream of compressor) in °C
(D)	Condensing pressure in bar(a)	Suction gas pressure in bar(a) Value underlined: Pressure control for suction gas is active, set suction gas pressure in bar(a)
(E)	Compressor output in %	
(F)	Temperature, refrigerant circuit controller	
(Z)	Compressor	
	<ul style="list-style-type: none"> ▪ Animated symbol: Compressor is running. ▪ When the refrigerant circuit is reversed the symbol appears turned by 180°. 	
(G)	Suction gas temperature (upstream of compressor) in °C	Hot gas temperature (downstream of compressor) in °C
(H)	Suction gas pressure in bar(a) Value underlined: Pressure control for suction gas is active, set suction gas pressure in bar(a)	Condensing pressure in bar(a)
(K)	Suction gas temperature (downstream of evaporator) in °C	Hot gas temperature in °C
(L)	Air intake temperature in °C	
R410A	Refrigerant	
(X)	Fan	
	Animated symbol: Fan is running.	
(M)	Speed, fan 1 (top) in %	
(N)	Speed, fan 2 (bottom) in %	
(O)	"t0:" Evaporation temperature in °C	"tc:" Condensing temperature in °C
🔥	—	Symbol flashes: Defrost active

Refrigerant circuit (cont.)

Pos.	Refrigerant circuit in heating mode	Refrig. circ reversal
	→ ⚡	← ⚡
Ⓟ	Suction gas superheating in K (downstream of evaporator) Position on evaporator (as shown in fig 29)	—
Ⓠ	Set value, suction gas superheating in K (downstream of evaporator) Position on evaporator (as shown in fig 29)	—
⚡	Electronic expansion valve: → Refrigerant circuit in heating mode, heat generation at condenser	← (flashes) Refrigerant circuit reversal active (cooling mode/defrosting)
Ⓡ	Suction gas superheating in K (upstream of compressor)	
Ⓢ	Electronic expansion valve opening in %	
Ⓣ	—	Set suction gas superheating in K
Ⓤ	LPG temperature in °C	Evaporation temperature in °C
Ⓥ	—	Suction gas superheating in K
Ⓦ	Secondary circuit return temperature in °C	
Ⓧ	"tc:" Condensing temperature in °C	"t0:" Evaporation temperature in °C
Ⓨ	Cylinder loading pump speed in %	
Ⓩ	Secondary pump speed in %	
Ⓜ	Secondary pump, cylinder loading pump Animated symbol: Pump is running.	

Refrigerant circ controller [4-6] / [4-7]

The following information can be called up:

- Refrigerant circuit temperature and pressure values
- Refrigerant circuit operating conditions

1. Service menu:

Press **OK** + simultaneously and hold for approx. 4 s.

2. "Diagnosis"

3. "Refrigerant circuit"

4. "Refrigerant circ controller"

Notes

- The symbols on the display are animated if the components are operational (e.g. pumps).
- The values shown are examples.

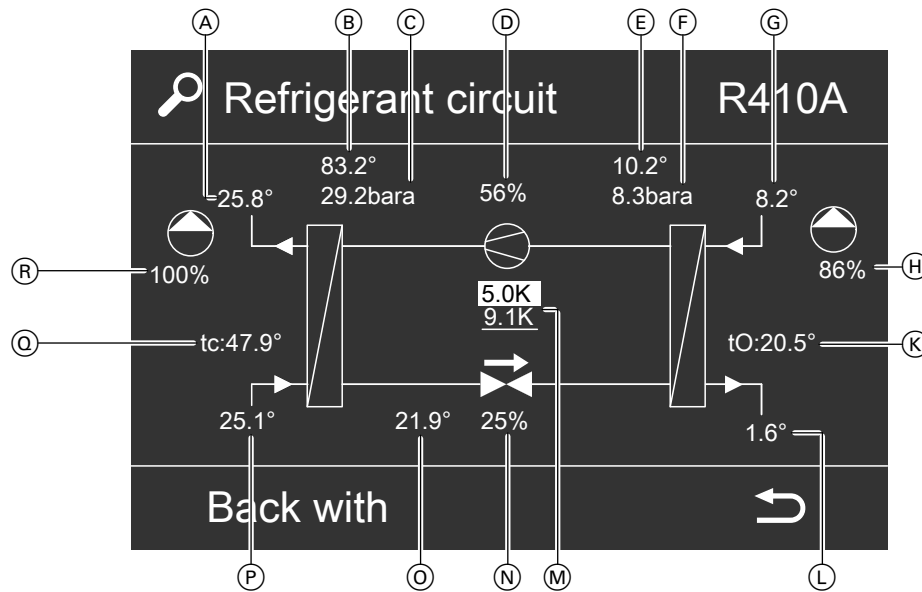

Fig. 30

Pos.	Meaning
(A)	Secondary circuit flow temperature in °C
(B)	Hot gas temperature in °C
(C)	Condensing pressure in bar(a)
(D)	Vitocal 333-G only: Compressor output in %
(M)	Compressor Animated symbol: Compressor is running.
(E)	Suction gas temperature in °C
(F)	Suction gas pressure in bar(a) Value underlined: Pressure control of suction gas is active.
R410A	Refrigerant
(G)	Primary circuit flow temperature in °C
(R)	Primary pump Animated symbol: Primary pump is running.
(H)	Primary pump speed in %
(K)	"tO:" Evaporation temperature in °C
(L)	Primary circuit return temperature in °C
(M)	Suction gas superheating in K Value highlighted white: Set suction gas superheating in K Value underlined: Suction gas superheating control active
(N)	Electronic expansion valve: → Refrigerant circuit in heating mode, heat generation at condenser
(O)	Electronic expansion valve opening in %
(P)	LPG temperature in °C
(Q)	Secondary circuit return temperature in °C
(R)	"tc:" Condensing temperature in °C
(S)	Secondary pump speed in %
(T)	Secondary pump, cylinder loading pump Animated symbol: Pump is running.

Refrigerant circuit (cont.)

Refrigerant circ controller [7] / [7-1]

The following information can be called up:

- Refrigerant circuit temperature and pressure values
- Refrigerant circuit operating conditions

1. Service menu:

Press **OK** + **≡**: simultaneously and hold for approx. 4 s.

2. "Diagnosis"

3. "Refrigerant circuit"

4. "Refrigerant circ controller"

Notes

- The symbols on the display are animated if the components are operational (e.g. pumps).
- The values shown are examples.

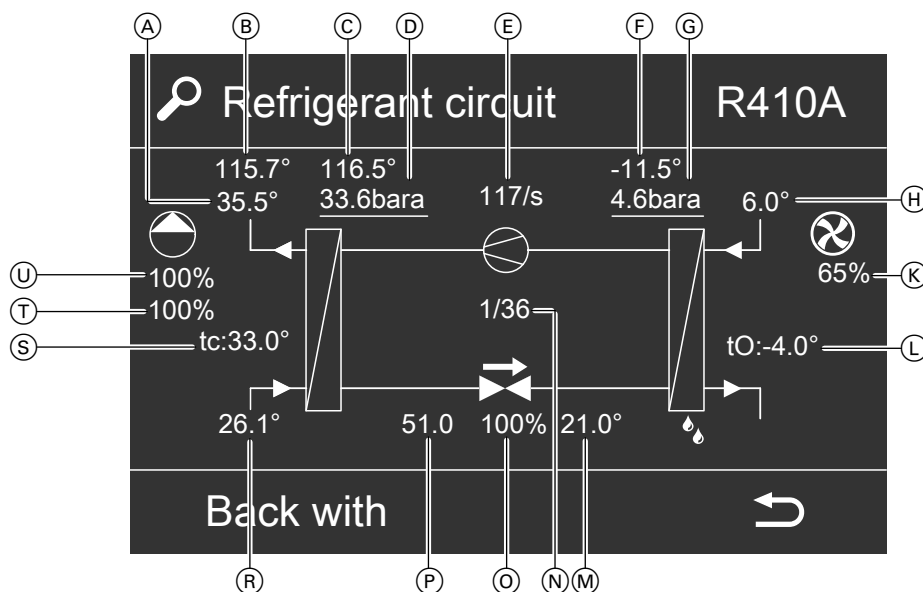

Fig. 31 Refrigerant circuit in heating mode, heat generation at condenser

Pos.	Refrigerant circuit in heating mode	Refrigerant circuit reversal
	→ ↔	← ↔
(A)	Secondary circuit flow temperature upstream of instantaneous heating water heater in °C	
(B)	Hot gas temperature (upstream of condenser) in °C	Suction gas temperature in °C
(C)	Hot gas temperature (downstream of compressor) in °C	Suction gas temperature (upstream of compressor) in °C
(D)	Hot gas pressure in bar(a)	—
(E)	Compressor speed in %	
(I)	Compressor ▪ Animated symbol: Compressor is running. ▪ When the refrigerant circuit is reversed the symbol appears turned by 180°.	
(F)	Suction gas temperature in °C	Hot gas temperature in °C
(G)	—	Condensing pressure in bar(a)
R410A	Refrigerant	
(H)	Air intake temperature in °C	
(K)	Fan Animated symbol: Fan is running.	
(K)	Fan speed in %	

Refrigerant circuit (cont.)

Pos.	Refrigerant circuit in heating mode	Refrigerant circuit reversal
	→ ▶▶	← ▶▶
Ⓐ	Evaporation temperature in °C Value highlighted white: Set evaporation temperature in °C	Condensing temperature in °C
Ⓓ	—	Symbol flashes: Defrost active
Ⓜ	—	Liquid gas temperature
▶▶	Electronic expansion valve: → Refrigerant circuit in heating mode, heat generation at condenser	← (flashes) Refrigerant circuit reversal active (cooling mode/defrosting)
Ⓐ	Refrigerant circuit protection functions 0/0 No protection active 1/4 High pressure protection 1/8 Protection against excessively high hot gas temperature 1/16 Constant fan speed when evaporation temperature is too high 1/32 Reduced fan speed when evaporation temperature is too high 1/64 Application limits of outdoor unit are exceeded or undershot. 1/128 Reduced compressor speed if high pressure limit has been reached. 1/256 Increased compressor speed if low pressure limit has been reached. Note <i>Multiple protection functions can be active simultaneously.</i> <i>Example 1/36:</i> <i>1/4 High pressure protection</i> <i>1/32 Reduced fan speed when evaporation temperature is too high</i>	Refrigerant circuit protection functions 0/0 No protection active 1/1 Frost protection, secondary circuit flow 1/2 Frost protection, refrigerant circuit 1/4 High pressure protection 1/8 Protection against excessively high hot gas temperature 1/64 Application limits of outdoor unit are exceeded or undershot. 1/128 Reduced compressor speed if high pressure limit has been reached. 1/256 Increased compressor speed if low pressure limit has been reached. 1/512 Increased fan speed when condensing temperature is too high
Ⓞ	Electronic expansion valve opening in %	
Ⓟ	Liquid gas temperature in °C	—
Ⓡ	Secondary circuit return temperature in °C	
Ⓢ	Condensing temperature in °C	Evaporation temperature in °C
Ⓣ	Cylinder loading pump speed in %	
Ⓤ	Secondary pump speed in %	
Ⓦ	Secondary pump, cylinder loading pump Animated symbol: Pump is running.	

Compressor travel

The diagram consisting of evaporation and condensing temperatures shows the compressor runtimes. The area of the diagram is divided into a rectangular grid. While the compressor is running, the operating point of the refrigerant circuit moves through this grid. The control unit constantly adds the dwell times "trun" of the operating point in the individual grid fields.

Depending on the dwell time, the grid is shown in various shades of grey:

- trun = 0 min: Black
- 0 < trun ≤ 240 min: 6 different shades of grey
- trun > 240 min: White

Based on the compressor application limits shown, it is possible to see whether and how often the application limits of the refrigerant circuit parameters have been exceeded during operation.

Refrigerant circuit (cont.)

1. **Service menu:**
Press **OK** + **≡**: simultaneously and hold for approx. 4 s.
2. **"Diagnosis"**
3. **"Refrigerant circuit"**
4. **"Compressor travel"** for single stage heat pump or
"Compressor travel 1" for compressor 1 with 2-stage refrigerant circuit or
"Compressor travel 2" for compressor 2 with 2-stage refrigerant circuit

Calculating runtimes

1. Use **◀/▶** to position the cursor (crosshairs) at the required place in the diagram.
2. Read off the values in the top line.

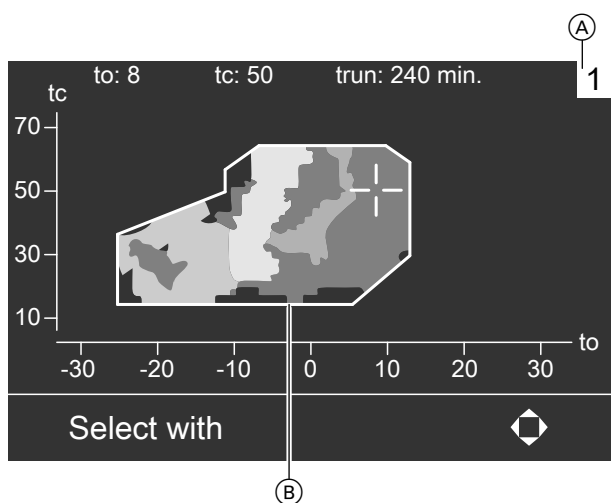

Fig. 32

- Ⓐ Diagram applicability:
 - 1 Heat pump or compressor 1 with 2-stage refrigerant circuit
 - 2 Compressor 2 with 2-stage refrigerant circuit
- Ⓑ Compressor application limits
- t0 Evaporation temperature
- tc Condensing temperature
- trun Compressor runtime for currently selected grid field

Compressor path

The diagram of the evaporation and condensing temperature shows the movement of the refrigerant circuit operating point (compressor path) for the last hour run. The compressor application limits pictured in the diagram show whether, and how often, the application limits of the refrigerant circuit parameters have been exceeded in the last hour run.

1. **Service menu:**
Press and hold **OK** + **≡**: simultaneously for approx. 4 s.
2. **"Diagnosis"**

3. **"Refrigerant circuit"**
4. **"Compressor path"** for single stage heat pump or
"Compressor path 1" for compressor 1 with 2-stage refrigerant circuit or
"Compressor path 2" for compressor 2 with 2-stage refrigerant circuit

Refrigerant circuit (cont.)

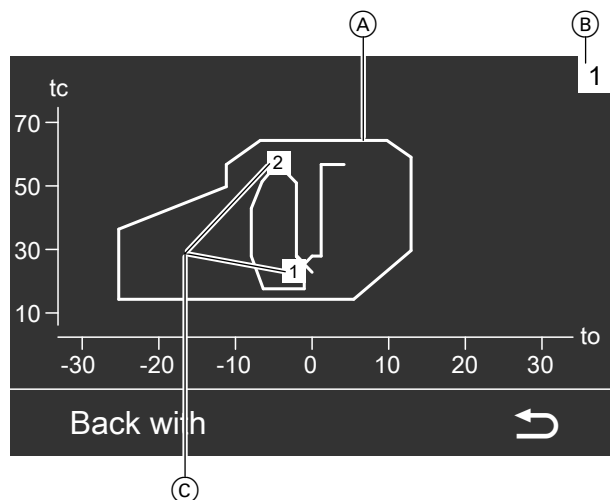

Fig. 33

- Ⓐ Compressor application limits
- Ⓑ Diagram applicability
 - 1 Heat pump compressor 1 with 2-stage refrigerant circuit
 - 2 Compressor 2 with 2-stage refrigerant circuit
- Ⓒ Stop times of the compressor (1 to N)
- t0 Evaporation temperature
- tc Condensing temperature

Message history [2]

For refrigerant circuit controller [2]: For differentiating between the refrigerant circuit controllers, see chapter "System information".

Message history of the refrigerant circuit controller (status and fault information):

- Messages cannot be acknowledged in the message history.
- Messages are listed in chronological order. The most recent message is listed first.
- Up to 30 entries are stored.

1. Service menu:

Press **OK** + **≡**: simultaneously and hold for approx. 4 s.

2. "Diagnosis"

3. "Refrigerant circuit"

4. "Message history"

Message overview

Note

Some faults should only be remedied by a (specialist) heating contractor certified for heat pumps by Viessmann.

Ⓐ	Ⓑ	Ⓒ	Ⓓ	Ⓔ
0	09.09.2009 17:16:00	06	Fault	7
1	09.09.2009 17:16:01	0A	Fault	3
2	09.09.2009 17:16:02	03	Note	11
3	09.09.2009 17:16:03	10	Fault	1

Fig. 34

- Ⓐ Message number
- Ⓑ Date and time of the last occurrence
- Ⓒ 2-digit message code
- Ⓓ Type of message: "Note" or "Fault"
- Ⓔ Frequency of occurrence

Refrigerant circuit controller messages can trigger a message at the heat pump control unit (see "Message overview"). Which message will be triggered at the heat pump control unit depends on the type of message at the refrigerant circuit controller.

Refrigerant circuit (cont.)

Type of message at refrigerant circuit controller	Message at heat pump control unit
[H] "Note"	"07 Fault refrigerant circ"
[S] "Fault"	"05 Fault refrigerant circ"

Message code	Meaning	Heat pump characteristics	Measure
00	—	No message	—
01	[S] Short circuit/lead break, air intake temperature sensor	Operation with temperature value of return temperature sensor in primary circuit, plus 3 K	Check resistance value (Pt500A) at the sensor connection of the EEV PCB: See "EEV PCB [2]".
02	[S] Short circuit/lead break, air discharge temperature sensor	Operation with temperature value of flow temperature sensor in primary circuit, minus 2 K	
03	[S] Short circuit/lead break suction gas temperature sensor	Compressor OFF	
04	[S] Short circuit/lead break, hot gas temperature sensor	<ul style="list-style-type: none"> ▪ Compressor remains in operation. ▪ Energy statement is not calculated correctly: See chapter "Diagnosis, energy statement". 	Check resistance value (Pt500A) at the sensor connection of the EEV PCB: See "EEV PCB [2]".
05	[S] Short circuit/lead break, high pressure sensor		Test voltage at the high pressure sensor connection: See "EEV PCB [2]". <ul style="list-style-type: none"> ▪ 0.5 V: 0 bar ▪ 4.5 V: Max. pressure, see sensor imprint.
06	[S] Short circuit/lead break liquid gas temperature sensor 1 (upstream of the EEV)	<ul style="list-style-type: none"> ▪ Compressor remains in operation. ▪ Energy statement is not calculated correctly: See chapter "Diagnosis, energy statement". 	Check resistance value (Pt500A) at the sensor connection of the EEV PCB: See "EEV PCB [2]".
07	[S] Short circuit/lead break liquid gas temperature sensor 2 (downstream of the EEV)		
08	[S] Short circuit/lead break, return temperature sensor, secondary circuit	Operation with temperature value of flow temperature sensor in secondary circuit, minus 5 K	
09	[S] Short circuit/lead break evaporator temperature sensor	Compressor may stop due to a change in refrigerant circuit conditions.	
0A	[S] Short circuit/lead break, low pressure sensor	Compressor OFF	Test voltage at the low pressure sensor connection: See "EEV PCB [2]". <ul style="list-style-type: none"> ▪ 0.5 V: 0 bar ▪ 4.5 V: Max. pressure, see sensor imprint.
10/11	[H] Compressor has stopped.		No action required
12	— Inverter fault (general message)	Subject to other messages	Observe other messages relating to the inverter (message codes "80" to "93").
15	[S] Inverter and compressor incompatible	Compressor OFF	Check whether the coding card matches the heat pump. To check information, see "System information".

Refrigerant circuit (cont.)

Message code	Meaning	Heat pump characteristics	Measure
1A	[S] Safety chain interrupted, compressor blocked	Compressor OFF	<ul style="list-style-type: none"> Check safety chain: See connection and wiring diagram. Check plug for compressor control on the EEV PCB: See "EEV PCB [2]".
20	[H] Condensing pressure too high (control high pressure)	Compressor OFF	As for " D4 Control high pressure ": See "Message overview" for the heat pump control unit.
21	[H] Inadequate evaporation pressure (low pressure fault)	Compressor OFF	As for " D3 Low pressure ": See "Message overview" for the heat pump control unit.
26	[H] Max. defrost time exceeded	Defrost is terminated early.	<ul style="list-style-type: none"> Check setting of "Evaporator temperature for defrost end 5010". Restore factory settings if necessary. Check function of 4-way diverter valve: See "Actuator test". If fault persists, notify a specialist.
27	[H] Compression ratio too high	Compressor OFF	<ul style="list-style-type: none"> Check high and low pressure sensors: See message codes "05" and "0A". <p>If the pressure sensors are OK but the fault persists:</p> <ul style="list-style-type: none"> Check the position of the operating point: See "Compressor travel" and/or "Compressor path". If necessary, reduce the set cylinder temperature.
28	[H] Max. high pressure	Compressor OFF	<ul style="list-style-type: none"> Have a specialist check the compressor parameters ("5xxx"). If necessary, reduce the set cylinder temperature.
2A	[H] Inverter power consumption too high	Compressor OFF	Test coil resistance at compressor. Resistance on all windings must be similar ($\pm 10\%$). For m Ω use a suitable measuring device.
2B	[H] Max. suction gas pressure exceeded	Compressor OFF	<ul style="list-style-type: none"> Check refrigerant charge. Adjust if necessary. If fault persists, notify a specialist.
2C	[H] Min. pressure differential between high and low pressure side has not been reached.	Compressor OFF	<ul style="list-style-type: none"> Check high and low pressure sensors: See message codes "05" and "0A".
2D	[H] Compression ratio too low	Compressor OFF	<p>If the pressure sensors are OK but the fault persists:</p> <ul style="list-style-type: none"> Check inverter power connections. Check whether the compressor is still running at a constant speed after starting: See "Refrigerant circuit controller [2]". Replace compressor if necessary.
2E	[H] Min. required high pressure undershot	Compressor OFF	<ul style="list-style-type: none"> Check high pressure sensor: See message code "05". Check refrigerant charge. Adjust if necessary.

Refrigerant circuit (cont.)

Message code		Meaning	Heat pump characteristics	Measure
2F	[H]	Min. required evaporation pressure undershot	Compressor OFF	<ul style="list-style-type: none"> Check low pressure sensor: See message code "0A". Check refrigerant charge. Adjust if necessary.
30	[H]	Operating point outside the compressor application limits for longer than max. time	Compressor OFF	<ul style="list-style-type: none"> Check the position of the operating point: See "Compressor travel" and/or "Compressor path". If fault persists, notify a specialist.
36	[H]	Min. pressure differential between high and low pressure side exceeded before compressor start	Compressor does not start.	<ul style="list-style-type: none"> Check high and low pressure sensors: See message codes "05" and "0A". Check secondary circuit flow rate. Check secondary pump. Ensure pressure compensation between the high pressure and low pressure sides. For this, switch the 4-way diverter valve with an "Actuator test".
48	—	Suction gas superheating too low	Compressor OFF	<ul style="list-style-type: none"> Check whether the correct coding card is fitted. To check information, see "System information". In the event of recurrence: Have the refrigerant circuit checked by a refrigeration engineer.
49	—	Evaporator max. operating pressure (MOP) has been reached; changeover from superheating to pressure control of the suction gas.	Compressor remains in operation.	No action required
4A	—	Evaporation temperature too low	Compressor remains in operation.	<ul style="list-style-type: none"> Check fan. Check evaporator for ice formation. Check evaporator temperature sensor: See message code "09".
80	[H]	Max. compressor current exceeded	Compressor OFF	Test coil resistance at compressor. Resistance on all windings must be similar ($\pm 10\%$). For m Ω use a suitable measuring device.
81	[H]	Max. compressor output exceeded	Compressor OFF	
82	[H]	Mains voltage too high	Compressor OFF	Test mains voltage at mains terminals: If mains voltage is too high (+10%), clarify the cause in consultation with the power supply utility.
83	[H]	Mains voltage too low	Compressor OFF	Test mains voltage at mains terminals: If mains voltage is too low (–10%), clarify the cause in consultation with the power supply utility.
84	[H]	Temperature at the inverter too high	Compressor OFF	Check fan at inverter heat sink. Replace inverter if necessary.
85	[H]	Temperature at inverter too low due to low outside temperature	Compressor OFF	No action required
86	[H]	Inverter power consumption too high	Compressor OFF	Test coil resistance at compressor. Resistance on all windings must be similar ($\pm 10\%$). For m Ω use a suitable measuring device.



Refrigerant circuit (cont.)

Message code	Meaning	Heat pump characteristics	Measure
87	[H] Temperature at compressor motor too high	Compressor OFF	<ul style="list-style-type: none"> Test coil resistance at compressor. Resistance on all windings should be similar. Replace compressor if necessary.
88	[S] Compressor drive fault	Compressor OFF	<ul style="list-style-type: none"> Test coil resistance at compressor. Resistance on all windings must be similar ($\pm 10\%$). For $m\Omega$ use a suitable measuring device. Replace compressor and/or inverter if necessary.
89	[S] Internal inverter fault	Compressor OFF	Replace inverter.
8A	[S] Internal inverter fault	Compressor is switched off or continues to run.	If fault occurs repeatedly, replace the inverter.
8B	[H] Internal inverter fault	Compressor OFF	<ul style="list-style-type: none"> Check inverter coil. Replace coil if necessary: See "EEV PCB [2]". Replace inverter if necessary.
8C	[H] Communication error	Compressor OFF	<ul style="list-style-type: none"> Isolate the inverter from the power supply. Then restore power supply. Replace inverter if the fault persists.
8D	[S] Short circuit/lead break, inverter temperature sensor	Compressor OFF	Replace inverter.
8E	[H] "Autotuning" function deactivated	Compressor remains in operation.	<ul style="list-style-type: none"> Test coil resistance at compressor. Resistance on all windings must be similar ($\pm 10\%$). For $m\Omega$ use a suitable measuring device. Replace compressor and/or inverter if necessary.
8F	[S] Compressor drive deactivated	Compressor OFF	<ul style="list-style-type: none"> Check jumpers on inverter, terminals 4 to 10. Observe the connection and wiring diagram for the heat pump: See "EEV PCB [2]". Replace inverter if necessary.
90	[H] Compressor control fault	Compressor OFF	<ul style="list-style-type: none"> Check connecting cable from inverter — compressor: See "EEV PCB [2]". <p>! Please note An incorrect rotating field will irreparably damage the compressor. When replacing the connecting cable, ensure the phases are connected correctly.</p>
91	[S] Fan fault at inverter heat sink	Compressor OFF	Check fan at inverter heat sink. Clean the fan if necessary: See "EEV PCB [2]".
92	[H] Compressor does not reach its set speed.	Compressor OFF	<ul style="list-style-type: none"> Check whether the correct coding card is fitted. In the event of recurrence: Have the refrigerant circuit checked by a refrigeration engineer.

Refrigerant circuit (cont.)

Message code	Meaning	Heat pump characteristics	Measure
93	[S] Compressor drive fault	Compressor OFF	<ul style="list-style-type: none"> Test coil resistance at compressor. Resistance on all windings must be similar ($\pm 10\%$). For $m\Omega$ use a suitable measuring device. Replace compressor and/or inverter if necessary.
94	[S] Inverter communication fault	Compressor OFF	<ul style="list-style-type: none"> Isolate the inverter from the power supply. Then restore power supply. Replace inverter if the fault persists.
98	[H] Voltage difference of individual phases too high (> 5 A)	Compressor OFF	Replace inverter.

Message history [4]

For refrigerant circuit controller [4]: For differentiating between the refrigerant circuit controllers, see chapter "System information".

Message history of the refrigerant circuit controller (status and fault information):

- Messages cannot be acknowledged in the message history.
- Messages are listed in chronological order. The most recent message is listed first.
- Up to 30 entries are stored.

1. Service menu:

Press **OK** + simultaneously and hold for approx. 4 s.

2. "Diagnosis"

3. "Refrigerant circuit"

4. "Message history"

Message overview

Note

Some faults should only be remedied by a (specialist) heating contractor certified for heat pumps by Viessmann.

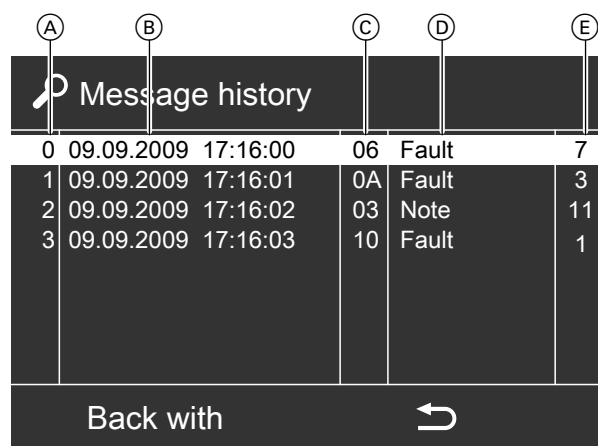

Fig. 35

- (A) Message number
- (B) Date and time of the last occurrence
- (C) 2-digit message code
- (D) Type of message: "Note" or "Fault"
- (E) Frequency of occurrence

Refrigerant circuit controller messages can trigger a message at the heat pump control unit (see "Message overview"). Which message will be triggered at the heat pump control unit depends on the type of message at the refrigerant circuit controller.

Type of message at refrigerant circuit controller	Message at heat pump control unit
[H] "Note"	"07 Fault refrigerant circ"
[S] "Fault"	"05 Fault refrigerant circ"

Refrigerant circuit (cont.)

Message code	Meaning	Heat pump characteristics	Measure
03	[S] Short circuit/lead break, suction gas temperature sensor	Compressor OFF	Check resistance value (NTC 10 kΩ) at connection J21 (T7) on the EEV PCB: See "EEV PCB [4]".
05	[S] Short circuit/lead break, high pressure sensor	Compressor OFF	Check current at connection J10 (P2) on the EEV PCB: See "EEV PCB [4]". Take refrigerant R410A into account.
06	[S] Short circuit/lead break liquid gas temperature sensor (downstream of refrigerant collector)		Check resistance value (NTC 10 kΩ) at connection J13 (T5) on the EEV PCB: See "EEV PCB [4]".
0A	[S] Short circuit/lead break, low pressure sensor (suction gas pressure sensor)	Compressor OFF	Check current at connection J10 (P1) on the EEV PCB: See "EEV PCB [4]". Take refrigerant R410A into account.
0D	[S] Short circuit/lead break, coding resistor		<ul style="list-style-type: none"> ▪ Check resistance at connection J10 (P3) on the EEV PCB. ▪ If necessary, contact Viessmann Werke technical services.
0E	[S] Short circuit/lead break, hot gas temperature sensor		Check 3-pole plug at the compressor (white, red and black wires). Replace hot gas temperature sensor if necessary.
0F	[S] Short circuit/lead break liquid gas temperature sensor (downstream of condenser)	Compressor OFF	Check resistance value (NTC 10 kΩ) at connection J13 (T5) on the EEV PCB: See "EEV PCB [4]".
10	[H] Compressor has stopped.		No action required
13	[S] Communication error	Compressor OFF	Check the electrical connection between the refrigerant circuit controller and the inverter.
18	[S] Compressor fault (general message)	Subject to other messages	See further messages regarding the compressor and inverter (message code "80" and above).
1E	[S] EEV PCB faulty	Compressor OFF	Replace EEV PCB.
20	[H] Condensing pressure too high (control high pressure)	Compressor OFF	As for " D4 Control high pressure ": See "Message overview" for the heat pump control unit.
21	[H] Inadequate evaporation pressure (low pressure fault)	Compressor OFF	As for " D3 Low pressure ": See "Message overview" for the heat pump control unit.
22	[H] Excessively high hot gas temperature	Compressor OFF	<ul style="list-style-type: none"> ▪ Have a specialist check the compressor parameters ("5xxx"). ▪ Check whether the coding card matches the heat pump. To check information, see "System information".
26	[H] Max. defrost time exceeded	Defrost is terminated early.	<ul style="list-style-type: none"> ▪ Check "Evaporator temperature for defrost end 5010". Restore factory settings if necessary. ▪ Check function of 4-way diverter valve: See "Actuator test".

Refrigerant circuit (cont.)

Message code	Meaning	Heat pump characteristics	Measure
27	[H] Compression ratio too high	Compressor OFF	<ul style="list-style-type: none"> Check high and low pressure sensors: See message codes "05" and "0A". <p>If the pressure sensors are OK but the fault persists:</p> <ul style="list-style-type: none"> Check the position of the operating point: See "Compressor travel" and/or "Compressor path". If necessary, reduce the set cylinder temperature.
29	[H] Condensing temperature too high	Compressor OFF	As for " D4 Control high pressure ": See "Message overview" for the heat pump control unit.
2B	[H] Max. suction gas pressure exceeded	Compressor OFF	<ul style="list-style-type: none"> Check amount of refrigerant. Adjust if necessary. If fault persists, notify a specialist.
2C	[H] Min. pressure differential between high and low pressure side has not been reached.	Compressor OFF	<ul style="list-style-type: none"> Check high and low pressure sensors: See message codes "05" and "0A". <p>If the pressure sensors are OK but the fault persists:</p> <ul style="list-style-type: none"> Check inverter power connections. Check whether the compressor is still running at a constant speed after starting: See "Refrigerant circuit controller [4]". Replace compressor if necessary.
2E	[H] Min. required high pressure undershot	Compressor OFF	<ul style="list-style-type: none"> Check high pressure sensor: See message code "05". Check amount of refrigerant. Adjust if necessary.
35	[H] Minimum suction gas temperature undershot	Compressor OFF	Check amount of refrigerant. Top up refrigerant if necessary. Further measures as for " D3 Low pressure ": See "Message overview" for the heat pump control unit.
3A	[S] Safety high pressure switch has responded.	Compressor OFF	As for " C9 Refrigerant circ (SHD) ": See "Message overview" for the heat pump control unit.
48	— Suction gas superheating too low	Compressor OFF	<ul style="list-style-type: none"> Check whether the correct coding card is fitted. To check information, see "System information". In the event of recurrence: Have the refrigerant circuit checked by a refrigeration engineer.
49	— Evaporator max. operating pressure (MOP) has been reached; changeover from superheating to pressure control of the suction gas.	Compressor remains in operation.	No action required

Refrigerant circuit (cont.)

Message code	Meaning	Heat pump characteristics	Measure
4C	— Suction gas superheating too high	Compressor OFF	<ul style="list-style-type: none"> Check whether the correct coding card is fitted. To check information, see "System information". In the event of recurrence: Have the refrigerant circuit checked by a refrigeration engineer.
55	[H] <ul style="list-style-type: none"> Too little refrigerant Electronic expansion valve for suction gas fully open 	Compressor OFF	<ul style="list-style-type: none"> Check amount of refrigerant. Adjust if necessary. Check plug at connection J11: See "EEV PCB [4]". Check stepper motor of electronic expansion valve.
56	[H] Condenser frost risk	<ul style="list-style-type: none"> Compressor OFF Refrigerant circuit reversal OFF 	<ul style="list-style-type: none"> Check hydraulics in the secondary circuit, e.g. whether all shut-off valves are fully open. Check secondary circuit flow rate. Check flow and return temperature in the secondary circuit. Check flow and return temperature sensor in the secondary circuit. Check amount of refrigerant. Adjust if necessary. Check temperature sensors in the refrigerant circuit.
57	[H] Electronic expansion valve for refrigerant collector level control fully open	Compressor OFF	<ul style="list-style-type: none"> Check plug at connection J7: See "EEV PCB [4]". Check stepper motor of electronic expansion valve.
58	— Liquid gas supercooling too high	Compressor remains in operation.	<ul style="list-style-type: none"> Check secondary circuit flow rate. If necessary, increase the flow rate. Check installation position of the liquid gas temperature sensor: See "Internal components". Check resistance value (NTC 10 kΩ) at connection J13 (T5) on the EEV PCB: See "EEV PCB [4]".
59	[S] Electronic expansion valve for suction gas superheating faulty	Compressor OFF	<ul style="list-style-type: none"> Check plug at connection J11: See "EEV PCB [4]". Check stepper motor of electronic expansion valve.
5A	[S] Electronic expansion valve for refrigerant collector level control faulty	Compressor OFF	<ul style="list-style-type: none"> Check plug at connection J7: See "EEV PCB [4]". Check stepper motor of electronic expansion valve.
5B	— Charge level in refrigerant collector too low	Compressor remains in operation.	Reduce set flow temperature for secondary circuit, e.g. by adjusting the heating curves.
5D	[H] Insufficient hot gas superheating	Compressor OFF	Check hot gas temperature sensor: See message code "0E".
65	[S] Charge level sensor of refrigerant collector faulty	Compressor remains in operation.	Check plug at connection J25/J26: See "EEV PCB [4]". Replace sensor if necessary.

Refrigerant circuit (cont.)

Message code	Meaning	Heat pump characteristics	Measure
81	[H] Torque of compressor drive too high	Compressor OFF	Test coil resistance at compressor. Resistance on all windings must be similar ($\pm 10\%$). For m Ω use a suitable measuring device.
82	[H] Mains voltage too high (> 420 V~) or intermediate circuit voltage too high	Compressor OFF	Test mains voltage at mains terminals: If mains voltage is too high (+10%), clarify the cause in consultation with the power supply utility.
83	[H] Mains voltage too low (< 380 V~) or intermediate circuit voltage too low	Compressor OFF	Test mains voltage at mains terminals: If mains voltage is too low (-10%), clarify the cause in consultation with the power supply utility.
84	[H] Temperature at inverter (IGBT) too high	Compressor OFF	Check fan at inverter heat sink. Replace inverter if necessary.
85	[H] Temperature at inverter (IGBT) too low	Compressor OFF	Replace inverter.
86	[H] Inverter power consumption (IGBT) permanently too high	Compressor OFF	Test coil resistance at compressor. Resistance on all windings must be similar ($\pm 10\%$). For m Ω use a suitable measuring device.
87	[H] Temperature at the compressor drive windings too high (> 90 °C)	Compressor OFF	<ul style="list-style-type: none"> ▪ No action required ▪ If problem recurs: Notify a specialist.
88	[S] Compressor drive blocked for more than 5 s.	Compressor OFF	<ul style="list-style-type: none"> ▪ Test coil resistance at compressor. Resistance on all windings must be similar ($\pm 10\%$). For mΩ use a suitable measuring device. ▪ Replace compressor and/or inverter if necessary.
89	[S] <ul style="list-style-type: none"> ▪ A-D converter fault ▪ Instrument transformer faulty 	Compressor OFF	Replace inverter.
8C	[H] Modbus communication error	Compressor OFF	Check Modbus connecting cable, inverter — EEV PCB.
8F	[S] Inverter switched off	Compressor OFF	
92	[H] Compressor does not reach its set speed.	Compressor OFF	<ul style="list-style-type: none"> ▪ Check that the correct coding card is fitted: See "System information". ▪ Check phase sequence on compressor.

Refrigerant circuit (cont.)

Message code	Meaning	Heat pump characteristics	Measure
95	[H] Discharge current at IGBT too high	Compressor OFF	Replace inverter.
96	[H] Precharge relay open	Compressor OFF	
97	[H] Voltage difference of individual phases too high (> 50 %)	Compressor OFF	
98	[H] Voltage difference of individual phases too high (> 5 A)	Compressor OFF	
99	[H] Current difference of power factor correction filter too high (> 10 A)	Compressor OFF	
9A	[H] Supply voltage of inverter control outside of voltage range	Compressor OFF	
9B	[H] Temperature of power factor correction filter too high	Compressor OFF	<ul style="list-style-type: none"> ▪ Test coil resistance at compressor. Resistance on all windings must be similar ($\pm 10\%$). For $m\Omega$ use a suitable measuring device. ▪ Replace inverter if necessary.
9C	[H] Outside temperature too low	Compressor OFF	No action required
9D	[H] Temperature differential of phase controls too high	Compressor OFF	<ul style="list-style-type: none"> ▪ Test coil resistance at compressor. Resistance on all windings must be similar ($\pm 10\%$). For $m\Omega$ use a suitable measuring device. ▪ Replace inverter if necessary.
9F	[H] More than 10 messages have occurred	Compressor OFF	Inverter is automatically reset. If message continues to be displayed, reset inverter in "Actuator test" .
B0	[S] Fan communication fault	Fan off, compressor remains in operation.	<ul style="list-style-type: none"> ▪ Check plug at connection J19: See "EEV PCB [4]". ▪ Check luster terminals in the heat pump terminal area if necessary.
B1	[S] Fan motor overheats	Fan off, compressor remains in operation.	<ul style="list-style-type: none"> ▪ Replace motor if it is mechanically sluggish in its movement. ▪ If the motor turns easily, notify a specialist.
B2	[S] Fan motor speed monitor faulty	Fan off, compressor remains in operation.	<ul style="list-style-type: none"> ▪ Check electrical connection of fan in heat pump terminal area. ▪ Replace fan motor if necessary. ▪ If fault persists, notify a specialist.
B3	[S] Fan motor blocked	Fan off, compressor remains in operation.	<ul style="list-style-type: none"> ▪ If motor is mechanically sluggish, remove blockage. Replace motor if necessary. ▪ If the motor turns easily, notify a specialist.
B4	[S] Fan motor supply voltage too low	Fan off, compressor remains in operation.	<ul style="list-style-type: none"> ▪ Check electrical connection of fan in heat pump terminal area. ▪ Replace fan motor if necessary. ▪ If fault persists, notify a specialist.

Refrigerant circuit (cont.)

Message history [4-3] / [4-4]

For refrigerant circuit controller [4-3] / [4-4]: For differentiating between the refrigerant circuit controllers, see chapter "System information".

Message history of the refrigerant circuit controller (status and fault information):

- Messages cannot be acknowledged in the message history.
- Messages are listed in chronological order. The most recent message is listed first.
- Up to 30 entries are stored.

1. Service menu:

Press **OK** + simultaneously and hold for approx. 4 s.

2. "Diagnosis"

3. "Refrigerant circuit"

4. "Message history"

Message overview

Note

Some faults should only be remedied by a (specialist) heating contractor certified for heat pumps by Viessmann.

(A)	(B)	(C)	(D)	(E)
0	09.09.2009 17:16:00	06	Fault	7
1	09.09.2009 17:16:01	0A	Fault	3
2	09.09.2009 17:16:02	03	Note	11
3	09.09.2009 17:16:03	10	Fault	1

Back with

Fig. 36

- (A) Message number
- (B) Date and time of the last occurrence
- (C) 2-digit message code
- (D) Type of message: "Note" or "Fault"
- (E) Frequency of occurrence

Refrigerant circuit controller messages can trigger a message at the heat pump control unit (see "Message overview"). Which message will be triggered at the heat pump control unit depends on the type of message at the refrigerant circuit controller.

Type of message at refrigerant circuit controller	Message at heat pump control unit
"Note"	"07 Message refrig. circ"
"Fault"	"05 Fault refrigerant circ"

Message code	Meaning	Heat pump characteristics	Measure
01	Short circuit/lead break, primary circuit flow temperature sensor (heat pump air intake)	Compressor OFF	Check resistance value (NTC 10 kΩ) at connection J13 (T5) of the EEV PCB: See "EEV PCB [4-3] / [4-4]".
03	Short circuit/lead break, suction gas temperature sensor	Compressor OFF	Check resistance value (NTC 10 kΩ) at connection J13 (T4) of the EEV PCB: See "EEV PCB [4-3] / [4-4]".
04	Short circuit/lead break, hot gas temperature sensor	Compressor OFF	Check resistance value (NTC 10 kΩ) at connection J13 (T6) of the EEV PCB: See "EEV PCB [4-3] / [4-4]".
05	Short circuit/lead break, high pressure sensor (liquid gas pressure sensor)	Compressor OFF	Check current at connection J10 (P2) of the EEV PCB: See "EEV PCB [4-3] / [4-4]". Take refrigerant R410A into account.
0A	Short circuit/lead break, low pressure sensor (suction gas pressure sensor)	Compressor OFF	Check current at connection J10 (P1) of the EEV PCB: See "EEV PCB [4-3] / [4-4]". Take refrigerant R410A into account.

Refrigerant circuit (cont.)

Message code	Meaning	Heat pump characteristics	Measure
0E	[S] Short circuit/lead break, suction gas temperature sensor (downstream of evaporator)	Compressor OFF	Check resistance value (NTC 10 kΩ) at connection J13 (T7) of the EEV PCB: See "EEV PCB [4-3] / [4-4]".
10	[H] Compressor has stopped.		No action required
13	[S] Communication error	Compressor OFF	Check the electrical connection between the refrigerant circuit controller and the inverter.
15	[S] Inverter and compressor incompatible	Compressor OFF	Check whether the coding card matches the heat pump. To check information, see "System information".
18	[S] Compressor fault (general message)	Subject to other messages	See further messages regarding the compressor and inverter (message code "80" and above).
1E	[S] EEV PCB faulty	Compressor OFF	Replace EEV PCB.
1F	— Parameter "Output compressor stage 5030" not set correctly	Compressor OFF	Set "Output compressor stage 5030" according to the type plate. Then switch off the heat pump control unit. Wait 1 min. Then restart the heat pump control unit.
20	[H] Condensing pressure too high (control high pressure)	Compressor OFF	As for "D4 Control high pressure": See "Message overview" for the heat pump control unit.
21	[H] Inadequate evaporation pressure (low pressure fault)	Compressor OFF	As for "D3 Low pressure": See "Message overview" for the heat pump control unit.
22	[H] Excessively high hot gas temperature	Compressor OFF	<ul style="list-style-type: none"> ▪ Have a specialist check the compressor parameters ("5xxx"). ▪ Check whether the coding card matches the heat pump. To check information, see "System information".
24	[S] Compressor failed to start: Message "88" has occurred 3 times successively.	Compressor OFF	<ul style="list-style-type: none"> ▪ Check compressor drive. ▪ Check inverter.
26	[H] Max. defrost time exceeded	Defrost is terminated early.	<ul style="list-style-type: none"> ▪ Check setting of "Evaporator temperature for defrost end 5010". Set to factory settings if necessary. ▪ Check function of 4-way diverter valve: See "Actuator test".
33	[H] Central heating/DHW heating: Secondary circuit flow temperature too low	Compressor remains in operation, but does not restart.	<ul style="list-style-type: none"> ▪ Check hydraulics in the secondary circuit, e.g. whether all shut-off valves are fully open. ▪ Check secondary circuit flow rate. ▪ Check flow and return temperature in the secondary circuit. ▪ Check flow and return temperature sensor in the secondary circuit. ▪ Check amount of refrigerant. Adjust the amount of refrigerant if necessary. ▪ Check temperature sensors in the refrigerant circuit.

Refrigerant circuit (cont.)

Message code		Meaning	Heat pump characteristics	Measure
3A	[S]	Safety high pressure switch has responded.	Compressor OFF	As for " C9 Refrigerant circ (SHD) ": See "Message overview" for the heat pump control unit.
43	[S]	Short circuit/lead break, temperature sensor, refrigerant circuit controller	Compressor OFF	Check resistance value (NTC 10 kΩ) at connection J21 (T2) of the EEV PCB: See "EEV PCB [4-3] / [4-4]".
44	[S]	Short circuit/lead break, secondary circuit flow temperature sensor (upstream of instantaneous heating water heater)	Compressor OFF	<ul style="list-style-type: none"> ▪ Vitocal 200-A/222-A: Check resistance value (NTC 10 kΩ) at connection J21 (T1) of the EEV PCB: See "EEV PCB [4-3] / [4-4]". ▪ Vitocal 200-S/222-S: Check resistance value (Pt500A) at connection X25.3/X25.4 of the controller and sensor PCB: See "Controller and sensor PCB".
46	[S]	Short circuit/lead break, liquid gas temperature sensor	Compressor OFF	<ul style="list-style-type: none"> ▪ Vitocal 200-A/222-A: Check resistance value (NTC 10 kΩ) at connection J21 (T3) of the EEV PCB: See "EEV PCB [4-3] / [4-4]". ▪ Vitocal 200-S/222-S: Check resistance value (Pt500A) at connection F25 (X25.17/X25.18) of the controller and sensor PCB: See "Controller and sensor PCB".
47	[S]	Short circuit/lead break, reversible suction gas temperature sensor	Compressor OFF	Check resistance value (Pt500A) at connection X25.15/X25.16 of the controller and sensor PCB: See "Controller and sensor PCB".
48	—	Suction gas superheating too low	Compressor OFF	<ul style="list-style-type: none"> ▪ Check whether the correct coding card is fitted. To check information, see "System information". ▪ In the event of recurrence: Have the refrigerant circuit checked by a refrigeration engineer.
49	—	Evaporator max. operating pressure (MOP) has been reached; changeover from superheating to pressure control of the suction gas.	Compressor remains in operation.	No action required
4C	—	Suction gas superheating too high	Compressor OFF	<ul style="list-style-type: none"> ▪ Check whether the correct coding card is fitted. To check information, see "System information". ▪ In the event of recurrence: Have the refrigerant circuit checked by a refrigeration engineer.
55	[H]	Too little refrigerant	Compressor OFF	Check amount of refrigerant. Adjust the amount of refrigerant if necessary.

Refrigerant circuit (cont.)

Message code		Meaning	Heat pump characteristics	Measure
56	[H]	Condenser frost risk	<ul style="list-style-type: none"> ▪ Compressor OFF ▪ Refrigerant circuit reversal OFF 	<ul style="list-style-type: none"> ▪ Check hydraulics in the secondary circuit, e.g. whether all shut-off valves are fully open. ▪ Check secondary circuit flow rate. ▪ Check flow and return temperature sensor in the secondary circuit: See "Controller and sensor PCB". ▪ Check amount of refrigerant. Adjust the amount of refrigerant if necessary. ▪ Check temperature sensors in the refrigerant circuit: See "EEV PCB [4-3] / [4-4]".
59	[S]	Electronic expansion valve faulty	Compressor OFF	<ul style="list-style-type: none"> ▪ Check plug at connection J7: See "EEV PCB [4-3] / [4-4]". ▪ Check stepper motor of electronic expansion valve.
5D	[H]	Insufficient hot gas superheating	Compressor OFF	Check hot gas temperature sensor: See message code "04".
5F	[S]	Communication error for the following temperature sensors: <ul style="list-style-type: none"> ▪ Reversible suction gas temperature sensor ▪ Secondary circuit flow temperature sensor (upstream of instantaneous heating water heater) ▪ Liquid gas temperature sensor 	Compressor OFF	As for " EF Modbus subscriber ": See "Message overview" for the heat pump control unit.
69	[S]	Calculation error, refrigerant circuit	Compressor OFF	No action required: Compressor starts up again.
6A	[H]	Air intake temperature too low	Compressor does not start.	No action required
6B	[H]	Air intake temperature too high	Compressor does not start.	
6C	[H]	Secondary circuit flow temperature too high	Compressor does not start.	If necessary, check the set temperatures of all heat sources in the heating system. Adjust the set temperatures if necessary.
6D	[H]	Central cooling: Secondary circuit flow temperature too low	Compressor does not start.	Check parameter settings for cooling (" 71xx "), e.g. " Min. flow temperature cooling 7103 ".
6E	[H]	Defrosting: Secondary circuit flow temperature too low	Compressor does not start.	<ul style="list-style-type: none"> ▪ As for "AA Cancel defrost": See "Message overview" for the heat pump control unit. ▪ Add more heat from secondary circuit, e.g. via additional heating water buffer cylinder in the return.
6F	[H]	Compressor speed below min. speed for 90 s	Compressor OFF	Check refrigerant circuit controller software version: See chapter "System information".

Refrigerant circuit (cont.)

Message code	Meaning	Heat pump characteristics	Measure
80	[H] Max. compressor current exceeded	Compressor OFF	Test coil resistance at compressor. Resistance on all windings must be similar ($\pm 10\%$). For $m\Omega$ use a suitable measuring device.
81	[H] Torque of compressor drive too high	Compressor OFF	
82	[H] Mains voltage too high or intermediate circuit voltage too high	Compressor OFF	Test mains voltage at mains terminals: If mains voltage is too high ($+10\%$), clarify the cause in consultation with the power supply utility.
83	[H] Mains voltage too low or intermediate circuit voltage too low	Compressor OFF	Test mains voltage at mains terminals: If mains voltage is too low (-10%), clarify the cause in consultation with the power supply utility.
84	[H] Temperature at inverter (IGBT module) too high	Compressor OFF	Check inverter heat sink for contamination. Replace inverter if required.
86	[H] Inverter power consumption (IGBT module) permanently too high	Compressor OFF	Test coil resistance at compressor. Resistance on all windings must be similar ($\pm 10\%$). For $m\Omega$ use a suitable measuring device.
88	[S] Compressor drive blocked for more than 5 s.	Compressor OFF	<ul style="list-style-type: none"> ▪ Test coil resistance at compressor. Resistance on all windings must be similar ($\pm 10\%$). For $m\Omega$ use a suitable measuring device. ▪ Replace compressor and/or inverter if required.
89	[S] <ul style="list-style-type: none"> ▪ Inverter processor or data store faulty ▪ A-D converter fault ▪ Instrument transformer faulty 	Compressor OFF	Replace inverter.
8C	[H] Modbus communication error	Compressor OFF	If the fault is continually present, have the compressor parameters (" 5xxx ") checked by a specialist.
8F	[S] Inverter blocked	Compressor OFF	Switch OFF the power supply to the outdoor unit. Wait at least 2 min. Switch the power ON again. Replace inverter if the fault persists.
99	[H] Current difference of the individual phases on the compressor too high	Compressor OFF	<p>Check connecting cable from inverter — compressor: See "Connection and wiring diagram".</p> <p>! Please note 400 V appliances: An incorrect rotating field will irreparably damage the compressor. When replacing the connecting cable, ensure the phases are connected correctly.</p>
9E	[S] 1 phase of inverter supply voltage missing.	Compressor OFF	Check inverter power supply.

Refrigerant circuit (cont.)

Message code	Meaning	Heat pump characteristics	Measure
A0	[S] Current sensor phase L1 of compressor supply voltage faulty	Compressor OFF	Replace inverter.
A1	[S] Current sensor phase L2 of compressor supply voltage faulty	Compressor OFF	
A2	[S] Current sensor phase L3 of compressor supply voltage faulty	Compressor OFF	
A3	[S] Current sensor power factor correction filter faulty	Compressor OFF	
A4	[S] Temperature sensor, inverter (IGBT module) faulty	Compressor OFF	
A5	[S] Temperature sensor power factor correction filter faulty	Compressor OFF	
A8	[H] Compressor drive overheated	Compressor OFF	
A9	[H] Current phase L1 of compressor too high	Compressor OFF	
AA	[H] Current phase L2 of compressor too high	Compressor OFF	
AB	[H] Current phase L3 of compressor too high	Compressor OFF	
AC	[H] Current of power factor correction filter too high (detected via sensor)	Compressor OFF	Replace inverter.
AD	[H] Current of power factor correction filter too high (detected via software)	Compressor OFF	
AE	[H] Voltage of power factor correction filter too high	Compressor OFF	
B3	[S] Motor of fan 1 (top) blocked	Fan off, compressor remains in operation.	<ul style="list-style-type: none"> ▪ If motor is mechanically sluggish, remove blockage. Replace motor if necessary. ▪ If the motor turns easily, notify a specialist.
B5	[S] Motor of fan 2 (bottom) blocked	Fan off, compressor remains in operation.	
C4	[H] Slip of compressor drive too high	Compressor OFF	No action required

Message history [4-6] / [4-7]

For refrigerant circuit controller [4-6] / [4-7]: For differentiating between the refrigerant circuit controllers, see chapter "System information".

Message history of the refrigerant circuit controller (status and fault information):

- Messages cannot be acknowledged in the message history.
- Messages are listed in chronological order. The most recent message is listed first.
- Up to 30 entries are stored.

Refrigerant circuit (cont.)

1. **Service menu:**
Press **OK** + **≡**: simultaneously and hold for approx. 4 s.
2. **"Diagnosis"**
3. **"Refrigerant circuit"**
4. **"Message history"**

Message overview

Note

Some faults should only be remedied by a (specialist) heating contractor certified for heat pumps by Viessmann.

Refrigerant circuit controller messages can trigger a message at the heat pump control unit (see "Message overview"). Which message will be triggered at the heat pump control unit depends on the type of message at the refrigerant circuit controller.

Type of message at refrigerant circuit controller	Message at heat pump control unit
H "Note"	"07 Fault refrigerant circ"
S "Fault"	"05 Fault refrigerant circ"

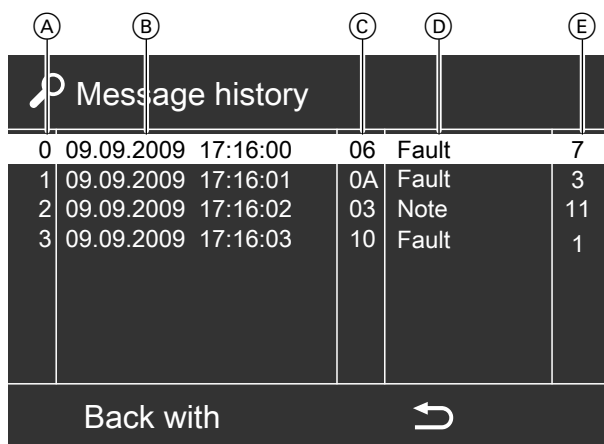

Fig. 37

- (A) Message number
- (B) Date and time of the last occurrence
- (C) 2-digit message code
- (D) Type of message: "Note" or "Fault"
- (E) Frequency of occurrence

Message code	Meaning	Heat pump characteristics	Measure
01	Short circuit/lead break, primary circuit flow temperature sensor (heat pump brine inlet)	Compressor OFF	Check resistance value (NTC 10 kΩ) at connection J13 (T5) of the EEV PCB: See "EEV PCB [4-6] / [4-7]".
03	Short circuit/lead break, suction gas temperature sensor	Compressor OFF	Check resistance value (NTC 10 kΩ) at connection J13 (T4) of the EEV PCB: See "EEV PCB [4-6] / [4-7]".
04	Short circuit/lead break, hot gas temperature sensor	Compressor OFF	Check resistance value (NTC 10 kΩ) at connection J13 (T6) of the EEV PCB: See "EEV PCB [4-6] / [4-7]".
05	Short circuit/lead break, high pressure sensor (liquid gas pressure sensor)	Compressor OFF	Check current at connection J10 (P2) of the EEV PCB: See "EEV PCB [4-6] / [4-7]". Take refrigerant R410A into account.
06	Short circuit/lead break, liquid gas temperature sensor	Compressor OFF	Check resistance value (NTC 10 kΩ) at connection J13 (T7) of the EEV PCB: See "EEV PCB [4-6] / [4-7]".

Refrigerant circuit (cont.)

Message code	Meaning	Heat pump characteristics	Measure
0A	[S] Short circuit/lead break, low pressure sensor (suction gas pressure sensor)	Compressor OFF	Check current at connection J10 (P1) of the EEV PCB: See "EEV PCB [4-6] / [4-7]". Take refrigerant R410A into account.
0E	[S] Short circuit/lead break, liquid gas temperature sensor	Compressor OFF	Check resistance value (NTC 10 kΩ) at connection J13 (T7) of the EEV PCB: See "EEV PCB [4-6] / [4-7]".
10	[H] Compressor switched off		No action required
13	[S] Vitocal 333-G: Communication error	Compressor OFF	Check Modbus connecting cable, inverter — EEV PCB.
15	[S] Vitocal 333-G: Inverter and compressor incompatible	Compressor OFF	Check the DIP switches on the EEV PCB are set correctly. Observe label for correct setting.
18	[S] Vitocal 333-G: Compressor fault (general message)	Subject to other messages	See further messages regarding the compressor and inverter (message code "80" and above).
1A	[S] Safety chain interrupted, compressor blocked	Compressor OFF	<ul style="list-style-type: none"> ▪ Check safety chain: See connection and wiring diagram. ▪ Check plug for compressor controller on the EEV PCB: See "EEV PCB [4-6] / [4-7]".
1E	[S] EEV PCB faulty	Compressor OFF	Replace EEV PCB.
1F	— Parameter " Output compressor stage 5030 " not set correctly	Compressor OFF	Set " Output compressor stage 5030 " according to the type plate. Then switch off the heat pump control unit. Wait 1 min. Then restart the heat pump control unit.
20	[H] Condensing pressure too high (control high pressure)	Compressor OFF	As for " D4 Control high pressure ": See "Message overview" for the heat pump control unit.
21	[H] Inadequate evaporation pressure (low pressure fault)	Compressor OFF	As for " D3 Low pressure ": See "Message overview" for the heat pump control unit.
22	[H] Excessively high hot gas temperature	Compressor OFF	<ul style="list-style-type: none"> ▪ Have a specialist check the compressor parameters ("5xxx"). ▪ Check whether the coding card matches the heat pump. To check information, see "System information".
24	[S] Compressor failed to start: Message " 88 " has occurred 3 times successively.	Compressor OFF	<ul style="list-style-type: none"> ▪ Check compressor drive. ▪ Vitocal 333-G: Check inverter.
29	[H] Condensing temperature too high	Compressor OFF	As for " D4 Control high pressure ": See "Message overview" for the heat pump control unit.
2B	[H] Max. suction gas pressure exceeded	Compressor OFF	<ul style="list-style-type: none"> ▪ Check amount of refrigerant. Adjust amount if required. ▪ If fault persists, notify a specialist.

Refrigerant circuit (cont.)

Message code		Meaning	Heat pump characteristics	Measure
2E	[H]	Min. required high pressure undershot	Compressor OFF	<ul style="list-style-type: none"> Check high pressure sensor: See message code "05". Check amount of refrigerant. Adjust amount if required.
33	[H]	Central heating/DHW heating: Secondary circuit flow temperature too low	Compressor remains in operation, but does not re-start.	<ul style="list-style-type: none"> Check hydraulics in the secondary circuit, e.g. whether all shut-off valves are fully open. Check secondary circuit flow rate. Check flow and return temperature in the secondary circuit. Check flow and return temperature sensor in the secondary circuit. Check amount of refrigerant. Adjust the amount of refrigerant if necessary. Check temperature sensors in the refrigerant circuit.
3A	[S]	Safety high pressure switch has responded.	Compressor OFF	As for " C9 Refrigerant circ (SHD) ": See "Message overview" for the heat pump control unit.
43	[S]	Short circuit/lead break, secondary circuit flow temperature sensor (downstream of instantaneous heating water heater)	Compressor OFF	Check resistance value (NTC 10 kΩ) at connection J21 (T2) of the EEV PCB: See "EEV PCB [4-6] / [4-7]".
44	[S]	Short circuit/lead break, secondary circuit flow temperature sensor (upstream of instantaneous heating water heater)	Compressor OFF	Check resistance value (NTC 10 kΩ) at connection J21 (T1) of the EEV PCB: See "EEV PCB [4-6] / [4-7]".
48	—	Suction gas superheating too low	Compressor OFF	<ul style="list-style-type: none"> Check whether the correct coding card is fitted. To check information, see "System information". In the event of recurrence: Have the refrigerant circuit checked by a refrigeration engineer.
49	—	Evaporator max. operating pressure (MOP) has been reached; changeover from superheating to pressure control of the suction gas.	Compressor remains in operation.	No action required
4A	—	Evaporation temperature too low	Compressor remains in operation.	Check primary pump.
4C	—	Suction gas superheating too high	Compressor OFF	<ul style="list-style-type: none"> Check whether the correct coding card is fitted. To check information, see "System information". In the event of recurrence: Have the refrigerant circuit checked by a refrigeration engineer.
54	[H]	Min. flow temperature primary circuit (brine inlet) not achieved.	Compressor OFF	Check primary circuit flow rate.

Refrigerant circuit (cont.)

Message code		Meaning	Heat pump characteristics	Measure
55	[H]	Too little refrigerant	Compressor OFF	Check amount of refrigerant. Adjust the amount of refrigerant if necessary.
56	[H]	Condenser frost risk	Compressor OFF	<ul style="list-style-type: none"> ▪ Check hydraulics in the secondary circuit, e.g. whether all shut-off valves are fully open. ▪ Check secondary circuit flow rate. ▪ Check flow and return temperature sensor in the secondary circuit: See "Controller and sensor PCB". ▪ Check amount of refrigerant. Adjust the amount of refrigerant if necessary. ▪ Check temperature sensors in the refrigerant circuit: See "EEV PCB [4-6] / [4-7]".
59	[S]	Electronic expansion valve faulty	Compressor OFF	<ul style="list-style-type: none"> ▪ Check plug at connection J7: See "EEV PCB [4-6] / [4-7]". ▪ Check stepper motor of electronic expansion valve.
5D	[H]	Insufficient hot gas superheating	Compressor OFF	Check hot gas temperature sensor: See message code "04".
69	[S]	Calculation error, refrigerant circuit	Compressor OFF	No action required: Compressor starts up again.
6A	[H]	Primary inlet temperature (brine inlet) too low	Compressor does not start.	As for " CB Flow temp. primary ": See "Message overview" for the heat pump control unit.
6B	[H]	Primary inlet temperature (brine inlet) too high	Compressor does not start.	Check primary circuit.
6C	[H]	Secondary circuit flow temperature too high	Compressor does not start.	If necessary, check the set temperatures of all heat sources in the heating system. Adjust the set temperatures if necessary.
6D	[H]	Room cooling: Secondary circuit flow temperature too low	Compressor does not start.	Check parameter settings for cooling (" 71xx "), e.g. " Min. flow temperature cooling 7103 ".
6F	[H]	Vitocal 333-G: Compressor speed below min. speed for 90 s	Compressor OFF	Check refrigerant circuit controller software version: See chapter "System information".
70	[S]	Short circuit/lead break, secondary circuit flow temperature sensor downstream of instantaneous heating water heater	Compressor OFF	Check resistance value (NTC 10 kΩ) at connection J21 (T2) of the EEV PCB: See "EEV PCB [4-6] / [4-7]".
71	[S]	Short circuit/lead break, secondary circuit return temperature sensor	Compressor OFF	Check resistance value (NTC 10 kΩ) at connection J21 (T3) of the EEV PCB: See "EEV PCB [4-6] / [4-7]".
80	[H]	Vitocal 333-G: Max. compressor current exceeded	Compressor OFF	Test coil resistance at compressor. Resistance on all windings must be similar (±10 %). For mΩ use a suitable measuring device.

Refrigerant circuit (cont.)

Message code	Meaning	Heat pump characteristics	Measure
81	[H] Vitocal 333-G: Torque of compressor drive too high	Compressor OFF	Test coil resistance at compressor. Resistance on all windings must be similar ($\pm 10\%$). For $m\Omega$ use a suitable measuring device.
82	[H] Vitocal 333-G: Mains voltage too high or intermediate circuit voltage too high	Compressor OFF	Test mains voltage at mains terminals: If mains voltage is too high (+10%), clarify the cause in consultation with the power supply utility.
83	[H] Vitocal 333-G: Mains voltage too low or intermediate circuit voltage too low	Compressor OFF	Test mains voltage at mains terminals: If mains voltage is too low (-10%), clarify the cause in consultation with the power supply utility.
84	[H] Vitocal 333-G: Temperature at inverter (IGBT module) too high	Compressor OFF	Check inverter heat sink for contamination. Replace inverter if necessary.
86	[H] Vitocal 333-G: Inverter power consumption (IGBT module) permanently too high	Compressor OFF	Test coil resistance at compressor. Resistance on all windings must be similar ($\pm 10\%$). For $m\Omega$ use a suitable measuring device.
88	[S] Vitocal 333-G: Compressor drive blocked for more than 5 s.	Compressor OFF	<ul style="list-style-type: none"> ▪ Test coil resistance at compressor. Resistance on all windings must be similar ($\pm 10\%$). For $m\Omega$ use a suitable measuring device. ▪ Replace compressor and/or inverter if necessary.
89	[S] Vitocal 333-G: <ul style="list-style-type: none"> ▪ Inverter processor or data store faulty ▪ A-D converter fault ▪ Instrument transformer faulty 	Compressor OFF	Replace inverter.
8F	[S] Vitocal 333-G: Inverter switched off	Compressor OFF	Check electrical connecting cable between inverter and compressor. Replace the connecting cable if necessary: See "Connection and wiring diagram".



Refrigerant circuit (cont.)

Message code	Meaning	Heat pump characteristics	Measure
99	[H] Vitocal 333-G: Current difference of the individual phases on the compressor too high	Compressor OFF	Check connecting cable from inverter — compressor. Replace the connecting cable if necessary: See "Connection and wiring diagram". ! Please note 400 V appliances: An incorrect rotating field will irreparably damage the compressor. When replacing the connecting cable, ensure the phases are connected correctly.
9B	[H] Vitocal 333-G: Temperature of power factor correction filter too high	Compressor OFF	<ul style="list-style-type: none"> ▪ Test coil resistance at compressor. Resistance on all windings should be similar ($\pm 10\%$). Use measuring device suitable for mΩ. ▪ Replace inverter if required.
9E	[S] Vitocal 333-G: 1 phase of inverter supply voltage missing.	Compressor OFF	Check inverter power supply.
A0	[S] Vitocal 333-G: Current sensor phase L1 of compressor supply voltage faulty	Compressor OFF	Replace inverter.
A1	[S] Vitocal 333-G: Current sensor phase L2 of compressor supply voltage faulty	Compressor OFF	
A2	[S] Vitocal 333-G: Current sensor phase L3 of compressor supply voltage faulty	Compressor OFF	
A3	[S] Vitocal 333-G: Current sensor power factor correction filter faulty	Compressor OFF	
A4	[S] Vitocal 333-G: Temperature sensor, inverter (IGBT module) faulty	Compressor OFF	
A5	[S] Vitocal 333-G: Temperature sensor power factor correction filter faulty	Compressor OFF	

Refrigerant circuit (cont.)

Message code		Meaning	Heat pump characteristics	Measure
A8	[H]	Vitocal 333-G: Compressor drive over-heated	Compressor OFF	<ul style="list-style-type: none"> Test coil resistance at compressor. Resistance on all windings must be similar ($\pm 10\%$). For mΩ use a suitable measuring device. Replace compressor and/or inverter if necessary.
A9	[H]	Vitocal 333-G: Current phase L1 of compressor too high	Compressor OFF	
AA	[H]	Vitocal 333-G: Current phase L2 of compressor too high	Compressor OFF	
AB	[H]	Vitocal 333-G: Current phase L3 of compressor too high	Compressor OFF	
AC	[H]	Vitocal 333-G: Current of power factor correction filter too high (detected via sensor)	Compressor OFF	Replace inverter.
AD	[H]	Vitocal 333-G: Current of power factor correction filter too high (detected via software)	Compressor OFF	
AE	[H]	Vitocal 333-G: Voltage of power factor correction filter too high	Compressor OFF	
B9	[S]	Secondary pump blocked	Compressor OFF	Check secondary pump. Replace the secondary pump if required.
BA	[S]	Secondary pump electrical fault	Compressor OFF	Carry out electrical check of secondary pump. Vitocal 222-G: <ul style="list-style-type: none"> Check voltage at connections J5 and J17 on the EEV PCB. Vitocal 333-G: <ul style="list-style-type: none"> Check voltage at connection J20 on the EEV PCB. See "EEV PCB [4-6] / [4-7]". Replace the secondary pump if required.
BB	[S]	Fault, PWM signal from secondary pump (actual speed)	Compressor remains in operation. Secondary pump continues to run at previously set speed, without monitoring.	Check PWM signal at secondary pump. Check signal at connection J26 on the EEV PCB: See "EEV PCB [4-6] / [4-7]". Replace the secondary pump if required.
BC	[S]	Secondary pump run dry	Compressor OFF	Fill the secondary circuit. Vent the secondary circuit.
C4	[H]	Vitocal 333-G: Slip of compressor drive too high	Compressor OFF	No action required
8C	[H]	Vitocal 333-G: Modbus communication error	Compressor OFF	Check Modbus connecting cable, inverter — EEV PCB.

Refrigerant circuit (cont.)

Message history [6]

For refrigerant circuit controller [6]: For differentiating between the refrigerant circuit controllers, see chapter "System information".

Message history of the refrigerant circuit controller (status and fault information):

- Messages cannot be acknowledged in the message history.
- Messages are listed in chronological order. The most recent message is listed first.
- Up to 30 entries are stored.

1. Service menu:

Press **OK** + **≡**: simultaneously and hold for approx. 4 s.

2. "Diagnosis"

3. "Refrigerant circuit"

4. "Message history"

Message overview

Note

Some faults should only be remedied by a (specialist) heating contractor certified for heat pumps by Viessmann.

(A)	(B)	(C)	(D)	(E)
0	09.09.2009 17:16:00	06	Fault	7
1	09.09.2009 17:16:01	0A	Fault	3
2	09.09.2009 17:16:02	03	Note	11
3	09.09.2009 17:16:03	10	Fault	1

Back with

Fig. 38

- (A) Message number
- (B) Date and time of the last occurrence
- (C) 2-digit message code
- (D) Type of message: "Note" or "Fault"
- (E) Frequency of occurrence

Refrigerant circuit controller messages can trigger a message at the heat pump control unit (see "Message overview"). Which message will be triggered at the heat pump control unit depends on the type of message at the refrigerant circuit controller.

Type of message at refrigerant circuit controller	Message at heat pump control unit
[H] "Note"	"07 Fault refrigerant circ"
[S] "Fault"	"05 Fault refrigerant circ"

Message code	Meaning	Heat pump characteristics	Measure
00	—	—	—
04	[S] Short circuit/lead break, hot gas temperature sensor	Both compressors OFF	Check resistance value (NTC 10 kΩ) at sensor connection on the EEV PCB: See "Controller PCB and EEV PCB [6]".
05	[S] Short circuit/lead break, high pressure sensor	Both compressors OFF	Test voltage at the high pressure sensor connection: See "Controller PCB and EEV PCB [6]". <ul style="list-style-type: none"> ■ 0.5 V: 0 bar ■ 4.5 V: Max. pressure, see sensor imprint.
08	[S] Short circuit/lead break, return temperature sensor, secondary circuit	Operation with temperature value of flow temperature sensor in secondary circuit, minus 5 K	Check resistance value (NTC 10 kΩ) at sensor connection on the controller PCB: See "Controller PCB and EEV PCB [6]".

Refrigerant circuit (cont.)

Message code	Meaning	Heat pump characteristics	Measure
0A	[S] Short circuit/lead break, low pressure sensor	Both compressors OFF	Test voltage at the low pressure sensor connection on the EEV PCB: See "controller PCB and EEV PCB [6]". <ul style="list-style-type: none"> 0.5 V: 0 bar 4.5 V: Max. pressure, see sensor imprint.
0B	[S] Short circuit/lead break, secondary circuit flow temperature sensor in the appliance	Both compressors OFF	Check resistance value (NTC 10 kΩ) at sensor connection on the controller PCB: See "Controller PCB and EEV PCB [6]".
0E	[S] Short circuit/lead break, suction gas temperature sensor	Both compressors OFF	Check resistance value (NTC 10 kΩ) at sensor connection on the EEV PCB: See "Controller PCB and EEV PCB [6]".
16	[H] Parameter " Output compressor stage 5030 " not set correctly	Both compressors OFF	Set " Output compressor stage 5030 " according to the type plate. Then switch off the heat pump control unit. Wait 1 min. Then restart the heat pump control unit.
1E	[S] Controller PCB faulty	Both compressors OFF	Replace controller PCB.
1F	— Parameter " Output compressor stage 5030 " not set correctly	Both compressors OFF	Set " Output compressor stage 5030 " according to the type plate. Then switch off the heat pump control unit. Wait 1 min. Then restart the heat pump control unit.
20	[H] Condensing pressure too high (control high pressure)	Both compressors OFF	As for " D4 Control high pressure ": See "Message overview" for the heat pump control unit.
21	[H] Inadequate evaporation pressure (low pressure fault)	Both compressors OFF	As for " D3 Low pressure ": See "Message overview" for the heat pump control unit.
25	[H] Operating point is outside the application limits.	Both compressors OFF	Check the position of the operating point: See "Compressor travel" and/or "Compressor path".
28	[H] Max. high pressure	Both compressors OFF	<ul style="list-style-type: none"> Have a specialist check the compressor parameters ("5xxx"). If necessary, reduce the set cylinder temperature.
2F	[H] Min. required evaporation pressure undershot	Both compressors OFF	<ul style="list-style-type: none"> Check low pressure sensor: See message code "0A". Check refrigerant charge. Adjust if necessary.
30	[H] Secondary circuit return temperature falls below 18 °C 4 times, one after the other, prior to defrosting.	Defrosting procedure does not start.	<ul style="list-style-type: none"> Reduce heat demand in the secondary circuit, e.g. lower the set room temperatures. Reduce heat transfer in the secondary circuit.
39	[H] Difference between flow temperature in the appliance and return temperature is larger than 12 K prior to defrosting.	Defrosting procedure does not start.	<ul style="list-style-type: none"> Reduce heat demand in the secondary circuit, e.g. lower the set room temperatures. Reduce heat transfer in the secondary circuit.

Refrigerant circuit (cont.)

Message code	Meaning	Heat pump characteristics	Measure
3A	[S] Safety high pressure switch has responded.	Both compressors OFF	As for " C9 Refrigerant circ (SHD) ": See "Message overview" for the heat pump control unit.
4A	— Evaporation temperature too low	Compressors remain operational.	<ul style="list-style-type: none"> Check fan. Check evaporator for ice formation. Check evaporator temperature sensor: See message code "09".
4B	[S] <ul style="list-style-type: none"> EEV connecting cable faulty EEV stepper motor faulty 	Both compressors OFF	<ul style="list-style-type: none"> Check the EEV connecting cable. Replace the connecting cable if necessary. Replace EEV.
56	[H] Condenser frost risk	<ul style="list-style-type: none"> Both compressors OFF Refrigerant circuit reversal OFF 	<ul style="list-style-type: none"> Check hydraulics in the secondary circuit, e.g. whether all shut-off valves are fully open. Check secondary circuit flow rate. Check flow and return temperature in the secondary circuit. Check secondary circuit flow temperature sensor in the appliance. Check refrigerant charge. Adjust if necessary. Check temperature sensors in the refrigerant circuit.
60	[S] DHW heating via auxiliary heat exchanger fault	DHW heating is stopped.	<ul style="list-style-type: none"> Check auxiliary heat exchanger flow rate. Check circulation pump for cylinder heating. Check cylinder loading pump.
61	[S] Fan fault	Compressor runs on for max. 5 min.	<ul style="list-style-type: none"> Check if fan is blocked. Carry out mechanical check of fan. Check fan control or PWM signal at the controller PCB: See "Controller PCB and EEV PCB [6]".
62	[S] Flow switch does not detect a flow rate.		<ul style="list-style-type: none"> Check secondary circuit flow rate. Check secondary pump. <p>Test voltage at the controller PCB connection: See "Controller PCB and EEV PCB [6]".</p> <ul style="list-style-type: none"> 0 V: Flow switch has responded. 230 V~: Flow switch has not responded.
63	[H] Lower outside temperature limit not reached	Both compressors OFF	No action required
66	[S] Motor overload relay or safety equipment at the soft starter has responded.	Compressor off. The other compressor may remain in operation.	<ul style="list-style-type: none"> Check soft starter. Check status input at the controller PCB: See "Controller PCB and EEV PCB [6]". Check motor currents/motor overload relay.

Refrigerant circuit (cont.)

Message code	Meaning	Heat pump characteristics	Measure
67	[S] Flow switch has responded.	Both compressors OFF	<ul style="list-style-type: none"> Check secondary circuit flow rate. Check secondary pump. <p>Test voltage at the controller PCB connection: See "Controller PCB and EEV PCB [6]".</p> <ul style="list-style-type: none"> 0 V: Flow switch has responded. 230 V~: Flow switch has not responded.
68	[S] Communication between controller PCB and EEV PCB is faulty	Both compressors OFF	<ul style="list-style-type: none"> Check connecting cable between controller PCB and EEV PCB. Replace the connecting lead if necessary. Replace EEV PCB. Replace controller PCB.
86	[H] Motor overload relay or safety equipment at the soft starter has responded.	Compressor blocked for 4 min	No action required

Message history [7] / [7-1]

Message history of the refrigerant circuit controller (status and fault information):

- Messages cannot be acknowledged in the message history.
- Messages are listed in chronological order. The most recent message is listed first.
- Up to 30 entries are stored.

1. Service menu:

Press **OK** + simultaneously and hold for approx. 4 s.

2. "Diagnosis"

3. "Refrigerant circuit"

4. "Message history"

Message overview

Note

Some faults should only be remedied by a (specialist) heating contractor certified for heat pumps by Viessmann.

(A)	(B)	(C)	(D)	(E)
0	09.09.2009 17:16:00	06	Fault	7
1	09.09.2009 17:16:01	0A	Fault	3
2	09.09.2009 17:16:02	03	Note	11
3	09.09.2009 17:16:03	10	Fault	1

Back with

Fig. 39

- (A) Message number
- (B) Date and time of the last occurrence
- (C) 2-digit message code
- (D) Type of message: "Note" or "Fault"
- (E) Frequency of occurrence

Refrigerant circuit controller messages can trigger a message at the heat pump control unit (see "Message overview"). Which message will be triggered at the heat pump control unit depends on the type of message at the refrigerant circuit controller.

Type of message at refrigerant circuit controller	Message at heat pump control unit
[H] "Note"	"07 Message refrig. circ"
[S] "Fault"	"05 Fault refrig. circ"

Refrigerant circuit (cont.)

Message code	Meaning	Heat pump characteristics	Measure
00	—	No message	—
01	[S] Short circuit/lead break, air intake temperature sensor, evaporator (outdoor)	Compressor OFF	Check resistance value (NTC 15 kΩ) at connection T-SENSOR2 on the main PCB: See "Main PCB [7] / [7-1]".
03	[S] Short circuit/lead break, suction gas temperature sensor	<ul style="list-style-type: none"> ▪ Compressor OFF ▪ Energy statement is not calculated correctly: See chapter "Diagnosis, Energy statement". 	Check resistance value (NTC 20 kΩ) at connection T-SENSOR3 on the main PCB: See "Main PCB [7] / [7-1]".
04	[S] Short circuit/lead break, hot gas temperature sensor, compressor (discharged)	<ul style="list-style-type: none"> ▪ Cooling mode: Compressor remains in operation. ▪ Heating mode: Compressor OFF 	Check resistance value (NTC 50 kΩ) at connection T-SENSOR2 on the main PCB: See "Main PCB [7] / [7-1]".
05	[S] Short circuit/lead break, high pressure sensor	<ul style="list-style-type: none"> ▪ Compressor OFF ▪ Energy statement is not calculated correctly: See chapter "Diagnosis, Energy statement". 	<ul style="list-style-type: none"> ▪ Check current at connection H_PRESS on the main PCB: See "Main PCB [7] / [7-1]". Take refrigerant into account. ▪ Check cable and main PCB.
09	[S] Short circuit/lead break, defrost temperature sensor	<ul style="list-style-type: none"> ▪ Cooling mode: Compressor remains in operation. ▪ Heating mode: Compressor OFF 	Check resistance value (NTC 20 kΩ) at connection T-SENSOR2 on the main PCB: See "Main PCB [7] / [7-1]".
10	[H] "Normal" compressor shutdown	Compressor OFF	No action required
15	[S] Jumper adaptor incorrectly inserted	Compressor OFF	<ul style="list-style-type: none"> ▪ Check if jumper adaptor is correctly inserted. ▪ Turn the outdoor unit off and on again.
17	[S] Compressor blocked	Compressor OFF	No action required; automatic reset of compressor
20	[H] Condensing pressure too high (control high pressure)	Compressor OFF	As for " D4 Control high pressure ": See "Message overview" for the heat pump control unit.
21	[H] Inadequate evaporation pressure (low pressure fault)	Compressor OFF	As for " D3 Low pressure ": See "Message overview" for the heat pump control unit.
22	[H] Hot gas temperature limit exceeded	Compressor OFF	Check whether the coding card matches the heat pump. To check information, see "System information".
24	[H] Compressor failed to start.	Compressor OFF	No action required; automatic reset of compressor
28	[H] As for message code " 20 "		
2F	[H] Min. required evaporation pressure undershot	Compressor OFF	<ul style="list-style-type: none"> ▪ Check the low pressure sensor. ▪ Check refrigerant charge. Adjust if necessary.
30	[H] Operating point outside the compressor application limits for longer than max. time	Compressor OFF	<ul style="list-style-type: none"> ▪ Check the position of the operating point: See "Compressor travel" and/or "Compressor path". ▪ If fault persists, notify a specialist.

Refrigerant circuit (cont.)

Message code	Meaning	Heat pump characteristics	Measure
34	[H] Evaporation temperature too low	<ul style="list-style-type: none"> ▪ Cooling mode: Compressor OFF ▪ Heating mode: Compressor remains in operation. 	Check reversible suction gas temperature sensor: Check resistance value (Pt500A) at connection X25.15/X25.16 of the controller and sensor PCB: See "Controller and sensor PCB".
39	[H] Hot gas temperature limit exceeded	Compressor OFF	Check whether the coding card matches the heat pump. To check information, see "System information".
3A	[S] Safety high pressure switch has responded.	Compressor OFF	As for " C9 Refrigerant circ (SHD) ": See "Message overview" for the heat pump control unit.
55	[H] Refrigerant loss	Compressor does not start.	<ul style="list-style-type: none"> ▪ Check refrigerant charge. ▪ Check refrigerant circuit for leaks.
56	[H] Frost protection, secondary circuit	Only in cooling mode: Compressor OFF	No action required
61	[H] Fan faulty	Compressor off: Message " A9 Heat pump " is shown.	As for " A9 Heat pump ": See "Message overview" for the heat pump control unit.
80	[H] Max. compressor current exceeded	Compressor OFF	No action required: Compressor is automatically reset.
82	[H] Voltage at inverter too high	Compressor OFF	
83	[H] Voltage at inverter too low	Compressor OFF	
86	[H] Inverter power consumption too high	Compressor OFF	
88	[S] Inverter fault	Compressor OFF	
8C	[H] Communication error	Compressor OFF	
8D	[S] Short circuit/lead break, inverter temperature sensor	Compressor OFF	Replace inverter.
90	[H] Compressor control fault	Compressor OFF	<ul style="list-style-type: none"> ▪ Check connecting cable from inverter — compressor. Replace the connecting cable if necessary: See "Connection and wiring diagram". ! Please note 400 V appliances: An incorrect rotating field will irreparably damage the compressor. When replacing the connecting cable, ensure the phases are connected correctly. ▪ Check contactor. Replace inverter if required.
91	[S] Fan fault at inverter heat sink	Compressor OFF	Check fan at inverter heat sink for leaks (see "Connection and wiring diagram"); clean if necessary.
92	[H] Fan does not reach its set speed.	Compressor OFF	In the event of recurrence: Have the refrigerant circuit checked by a refrigeration engineer.

Refrigerant circuit (cont.)

Message code	Meaning	Heat pump characteristics	Measure
97	[H] Voltage difference of individual phases too high (> 50 %)	Compressor OFF	<ul style="list-style-type: none"> Check the compressor connecting cable. Replace the connecting cable if necessary. ! Please note 400 V appliances: An incorrect rotating field will irreparably damage the compressor. When replacing the connecting cable, ensure the phases are connected correctly. Replace inverter if required.
99	[H] Current difference of power factor correction filter too high (> 10 A)	Compressor OFF	Replace inverter.
9B	[H] Temperature of power factor correction filter too high	Compressor OFF	<ul style="list-style-type: none"> Test coil resistance at compressor. Resistance on all windings must be similar ($\pm 10\%$). For $m\Omega$ use a suitable measuring device. Replace inverter if required.
9D	[H] Temperature differential of phase controls too high	Compressor OFF	<ul style="list-style-type: none"> Test coil resistance at compressor. Resistance on all windings must be similar ($\pm 10\%$). For $m\Omega$ use a suitable measuring device. Replace inverter if required.
9E	[S] Voltage at inverter too low	Compressor OFF	No action required; automatic reset of compressor
9F	[H] More than 3 messages occurred within 1 h	Compressor off: Message " A9 Heat pump " is shown.	As for " A9 Heat pump ": See "Message overview" for the heat pump control unit.
B3	[S] Fan motor blocked	Fan off, compressor remains in operation.	<ul style="list-style-type: none"> If motor is mechanically sluggish, remove blockage. Replace motor if necessary. If the motor turns easily, notify a specialist.
C0	[S] Inverter reset	Compressor OFF	No action required: Compressor is automatically reset.
C1	[S] Current capture fault, inverter	Compressor OFF	Replace inverter.
C2	[S] Phase reversal, inverter	Compressor OFF	Connect inverter with correct phases.
C3	[S] Fault, load circuit, inverter	Compressor OFF	Replace inverter.

Energy statement

Note

- The "**Energy statement**" will only be displayed if "**User level for display, energy stmt 8811**" is set to "**1**" or "**2**".
- Prerequisite for recording realistic data:**
Parameter "**Output compressor stage 5030**" is set correctly.

Energy statement (cont.)

Calling up the energy statement

1. **Service menu:**
Press and hold **OK** + **≡**: simultaneously for approx. 4 s.
2. **"Diagnosis"**
3. **"Energy statement"**
4. Select the required energy statement: See table below.

The following energy statements can be displayed:

"Energy statement heating" ("Energy statement htg 1", "Energy statement htg 2" with a 2-stage heat pump)

⌚	Electrical energy used for operating the heat pump.
🔥	Heating energy transferred into the heating system

"Energy statement DHW" ("Energy statement DHW 1", "Energy statement DHW 2" with a 2-stage heat pump)

⌚	Electrical energy used for operating the heat pump.
🚿	Heating energy transferred for DHW heating

"Energy statem. cooling" ("Energy statem. cooling 1", "Energy statem. cooling 2" with a 2-stage heat pump)

⌚	Electrical energy used for operating the heat pump.
❄️	Heating energy drawn from the heating system for cooling

"PV energy statement"

⌚	Electrical energy generated by the PV system used for operating the heat pump (utilisation of power generated on site).
☀️	Total power generated by the PV system

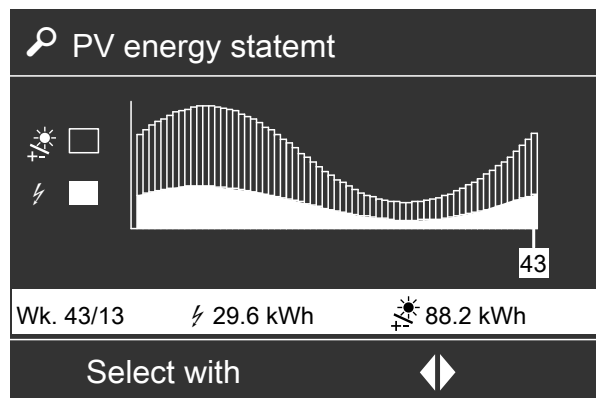

Fig. 40

The energy values **🔥**, **🚿**, **⌚**, **☀️** can be scanned with **◀▶** for every calendar week **"Wk"** of the past 12 months.

Calling up the seasonal performance factor

1. **Service menu:**
Press and hold **OK** + **≡**: simultaneously for approx. 4 s.
2. **"Diagnosis"**
3. **"Energy statement"**
4. Select required seasonal performance factor:
 - **"SPF heating"**:
Seasonal performance factor for central heating
 - **"SPF DHW"**:
Seasonal performance factor for DHW heating
 - **"SPF cooling"**:
Seasonal performance factor for central cooling
 - **"SPF PV"**:
Seasonal performance factor for utilisation of power generated on site
 - **"SPF overall"**:
Seasonal performance factor overall

Photovoltaics

PV statistics

Overview for utilisation of power generated on site:
The following information is displayed:

- Exported or drawn electrical output
- Heating system functions enabled and/or active for utilisation of power generated on site

1. Service menu:

Press and hold **OK** +  simultaneously for approx. 4 s.

2. "Diagnosis"

3. "Photovoltaics"

4. "PV statistics"

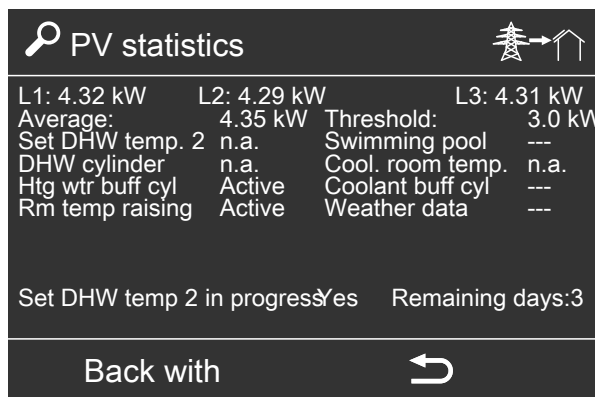

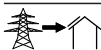



Fig. 41

Meaning of values and symbols

Display	Meaning
	Excess electrical energy from the photovoltaic system is fed into the power grid. The electrical power consumed by the heating system is taken into account (utilisation of power generated on site), with the exception of lag heat pumps in a heat pump cascade.
	Power from the grid is consumed in the building.
	<ul style="list-style-type: none"> ▪ Consumers in the building and the heating system are not consuming electrical energy. or ▪ The energy meter is faulty.
"L1", "L2", "L3"	<p>Electrical power measured by the energy meter in kW for each phase: Positive value: Electrical power is fed into the power grid. Negative value: Electrical power is drawn from the power grid.</p> <p>Note <i>The polarity can be changed by a heat pump installer certified by Viessmann.</i></p>
"Average"	Average of electrical outputs of all 3 phases, averaged over the last 10 min
"Threshold"	<ul style="list-style-type: none"> ▪ Setting value of parameter "Threshold for electrical power 7E04" or ▪ If "Threshold for electrical power 7E04" is set to "0": 25 % of "Compressor output 5030"

Heating system functions for utilisation of power generated on site:

- "n.a." Function not enabled
- "—" Function enabled but not active
- "Active" Function enabled and active

"Set DHW temp. 2"	Once a week, the DHW cylinder is fully heated with power from the photovoltaic system to "Set DHW temperature 2 600C" ("Enable own energy consumptn for set DHW temperature 2 7E10").
"Swimming pool"	Function not available
"DHW cylinder"	DHW heating with utilisation of power generated on site ("Enable own energy consumption for DHW heating 7E11")
"Cool. room temp."	Central cooling with utilisation of power generated on site ("Enable own energy consumption for cooling 7E15")
"Htg wtr buff cyl"	Heating the buffer cylinder with utilisation of power generated on site ("Enable own energy consumptn for heating water buffer cyl. 7E12")

Photovoltaics (cont.)

Display	Meaning
"Coolant buff cyl"	Cooling the heating water/coolant buffer cylinder with utilisation of power generated on site ("Enable own energy consumptn for coolant buffer cylinder 7E16")
"Rm temp raising"	Central heating with utilisation of power generated on site ("Enable own energy consumption for heating 7E13")
"Weather data"	Function not available
"DHW loading in progress"	<p>"Yes" DHW cylinder was fully heated up at least once on current day, with or without utilisation of power generated on site. Set cylinder temperatures:</p> <ul style="list-style-type: none"> ▪ Without utilisation of power generated on site: "Set DHW temperature 6000" ▪ With utilisation of power generated on site: "Set DHW temperature 6000" plus "Raise set DHW cylinder temperature PV 7E21" <p>"No" DHW cylinder has not yet been heated up on current day.</p>
"Set DHW temp 2 in progress"	<p>"Yes" During the last week, the DHW cylinder was fully heated to "Set DHW temperature 2 600C".</p> <p>"No" During the last week, the DHW cylinder was not fully heated to "Set DHW temperature 2 600C".</p>
"Remaining days:"	Number of days, until heating the DHW cylinder to "Set DHW temperature 2 600C" is required again.

DHW loading statistics

Overview of DHW heating events on days of the previous week

"Current" shows the information about the current day.

1. **Service menu:**
Press and hold **OK** + **≡**: simultaneously for approx. 4 s.
2. **"Diagnosis"**
3. **"Photovoltaics"**
4. **"DHW loading statistics"**

Example:
The current day is Tuesday.
Information about the current day can be found under **"Current"**. **"Tuesday"** indicates the information about Tuesday of the previous week.

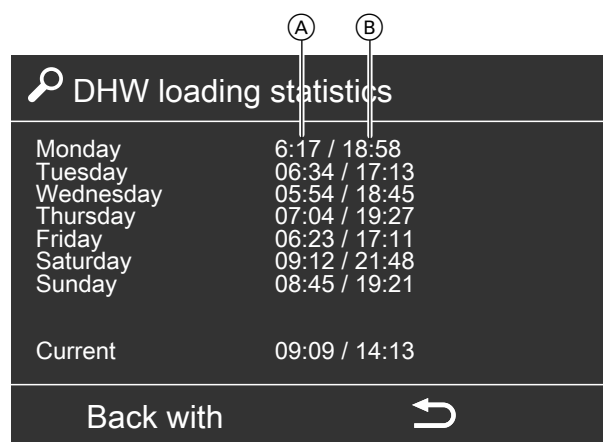



Fig. 42

- (A) Time of **first** DHW heating on that day
- (B) Time of **last** DHW heating on that day

Output curves

Daily curve of electrical power used for utilisation of power generated on site by the heating system. This daily curve can be called up for every day of the previous week.

1. **Service menu:**
Press and hold **OK** +  simultaneously for approx. 4 s.
2. **"Diagnosis"**
3. **"Photovoltaics"**
4. **"Output curves"**
5. Select the required day of the week with .

Example:

The current day is Friday.
The current daily curve can be found under **"D"**. The curve for Friday of the previous week is displayed under **"Fr"**.

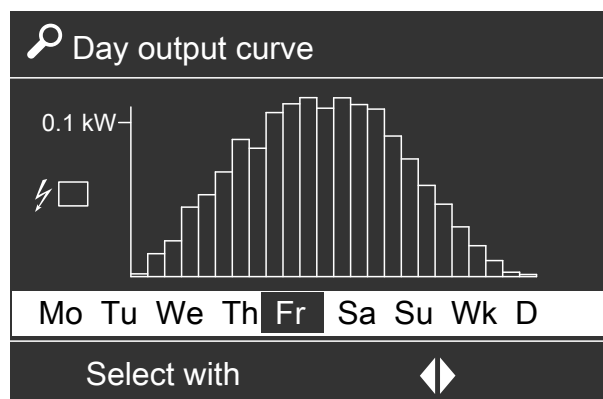

Fig. 43 1 bar is shown for every hour of the day. The height of the bar indicates the average electrical power over 1 h.

- "Mo" to "Su"** Daily curve Monday to Sunday
- "Wk"** Daily curve averaged over all days of the previous week
- "D"** Daily curve of current day up to current time

Brief scan

The following information can be called up:

- Software versions
- Connected components

1. **Service menu:**
Press **OK** +  simultaneously and hold for approx. 4 s.
2. **"Diagnosis"**
3. **"Brief scan"**



Fig. 44

Brief scan (cont.)

Explanation of the relevant values on the individual lines and fields

Line	Field					
	1	2	3	4	5	6
01:	System scheme 01 to 11		Software version Heat pump control unit		Software version Programming unit	
02:	Coding card: ID Low		Coding card: Version		Device recognition (CU-ID)	
03:	0		Number of KM-BUS subscribers		Software version, Vitosolic or solar control module, type SM1	
04:	Hardware index, refrigerant circuit controller		Software index, refrigerant circuit controller		Software version, mixer extension kit for heating/cooling circuit M3/HC3	Software version, mixer extension kit for separate cooling circuit
05:	0		0		Software version, AM1 extension	Software version, EA1 extension
06:	0: No external demand 1: External demand	0: No external blocking 1: External blocking	Software version, external H1 extension	0	Software index, outdoor unit ⊗ □	
07:	LON Subnet address/system no.		LON Node address/subscriber no.		0	
08:	LON: SNVT configuration	LON: Software version, communication coprocessor	LON: Neuron chip software version		Number of LON subscribers	
09:	Heating/cooling circuit without mixer A1/HC1 Remote control 0: Not installed 1: Installed		Heating/cooling circuit with mixer M2/HC2 Remote control 0: Not installed 1: Installed		Heating/cooling circuit with mixer M3/HC3 Remote control 0: Not installed 1: Installed	
10:	Software version "High", heat pump control unit		Software version "Low", heat pump control unit		Software version, programming unit	

System information

- Service menu:**
Press **OK** +  simultaneously and hold for approx. 4 s.
- "Diagnosis"**
- "System information"**

System information

VC 200-S
7745148240125546

Control	B920W247 / 9 B920W247/ BEF5
Heat pump	4.70/20
Coding card	4131-F0/4D
Refrigerant circ ctrllr 1	[4-4] / 01 / 0C
Ventilation	F0 / 0F
Wireless components	2,1 / 1 / - / 1
Th 22.06.2017 12:02 o'clock	

Terminate with **OK**

Fig. 45

System information (cont.)

Information displayed

Information	Value	Meaning
"VC 100-S", "VC 111-S", "VC 200-A", "VC 222-A" or "VC 200-S", "VC 222-S", "VC 222-G", "VC 333-G"		Heat pump product name: "VC" stands for "Vitocal".
"7745148240125546"		Serial number of the indoor unit: State when making a service request.
"Operation"		State when making a service request.
"Heat pump"		
"Coding card"		
"Refrigerant circ ctrllr 1"	"[4-4]"	
	"01"	Hardware index, refrigerant circuit controller: See chapter "Brief scan".
	"0C"	Software index, refrigerant circuit controller: See chapter "Brief scan".
"Ventilation"		State when making a service request.
"Wireless components"	"2.1"	Software index of wireless base station
	"1"	Software index of wireless remote control for heating circuit A1/HC1
	"-"	Software index of wireless remote control for heating circuit M2/HC2: No remote control connected
	"1"	Software index of wireless remote control for heating circuit M3/HC3

Actuator test (testing outputs)

- Only those actuators are shown that are installed and can be controlled, according to system equipment level.
- Activating the actuator test switches all actuators to zero volt.
- Individual actuators can be started in succession in this menu.
- All actuators can be switched off simultaneously.
- The actuator test stops automatically after approx. 30 min or with ↵.

1. Service menu:

Press and hold **OK** +  simultaneously for approx. 4 s.

2. "Actuator test".

3. Select required actuator.
4. Set the required condition: See the following table.
5. Use  to call up the **"System overview"** and the diagnostic page **"Refrigerant circ controller"**, **without** terminating the actuator test. Back to the actuator test display with **OK**.

Component	Possible modes
3-way diverter valve for "Central heating/DHW heating"	"Htg"/"DHW"
<ul style="list-style-type: none"> ▪ 3-way diverter valve for heating water buffer cylinder bypass in cooling mode ▪ 4-way diverter valve (not available on all heat pumps) 	"Heating"/"Cooling"
Mixer	"Open"/"Closed"/"Stop"
<ul style="list-style-type: none"> ▪ Actuators without output-dependent control e.g. circulation pumps, compressors without output-dependent control, external heat generators, electric ribbon heaters, etc. ▪ Reset inverter ("Reset inverter") 	"ON"/"OFF"
Actuators with output-dependent control, e.g. circulation pumps with PWM control, compressors with output-dependent control, fans with PWM control, etc.	"OFF"/"MIN"/"MAX"
Electronic expansion valves	"AUTO"/"MIN"/"MAX"
"All actuators OFF" All actuators are switched off simultaneously.	"Yes"/"No"

Sensor matching

Sensor matching

To compensate for system-based measuring faults, an adjustment value (offset) can be set for the following temperature sensors:

- Temperature sensors connected to the controller and sensor PCB
- Room temperature sensors which are integrated into or connected to the remote control.

The correction value can be positive or negative. The correction value is added to the current temperature reading.

1. Service menu:

Press and hold **OK** + **≡** simultaneously for approx. 4 s.

2. "Sensor matching"

3. Select sensor.

4. Set and apply adjustment value.

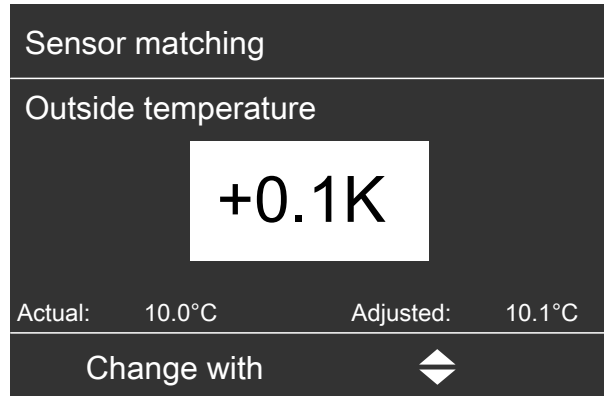

Fig. 46

"Actual":

Temperature reading

"Adjusted":

Adjusted temperature value

LON subscriber check

To check the communication between the heat pump control unit and connected LON subscribers.

Requirements:

- Heat pump control unit is **fault manager ("LON fault manager 7779")**.
- A unique subscriber number is set for every connected subscriber ("**LON subscriber number 7777**").
- The LON subscriber list in the fault manager is up to date.

1. Service menu:

Press and hold **OK** +  simultaneously for approx. 4 s.

2. "Service functions"

3. "Subscriber check"

4. Select LON subscriber.

5. Start the subscriber check with **OK**.

Possible displays:

- No display (status unknown):
LON subscriber has not yet responded, but has not yet been identified as failed.
- **"Failed"** :
LON subscriber has not responded for more than 20 min ("**Interval for data transfer via LON 779C**").
- **"Check"**:
Displayed for the duration of the subscriber check. **"WINK"** flashes on the display of the selected LON subscriber for around 30 s.
- **"Check OK"**:
Successful communication between the heat pump control unit and the LON subscriber
- **"OK"/"Fault"**:
LON subscriber has responded. Everything is OK or the LON subscriber has a fault.
- **"Check ERR"**:
No communication between the heat pump control unit and the LON subscriber.
Check the LON connection and LON parameters.

Service PIN

To identify the integral LON communication module, the heat pump control unit sends a message to **all** other LON subscribers.

Note

Only required with "tool binding", i.e. if the heat pump control unit is integrated into a LON with devices from other manufacturers, e.g. BMS system.



Viessmann LON manual

1. Service menu:

Press and hold **OK** +  simultaneously for approx. 4 s.

2. "Service functions"

3. "Service PIN"

The message is being sent. No operation is possible for approx. 4 s.

Subscribers (Modbus/KM-BUS)

List of all subscribers connected to the control unit via Modbus or KM-BUS. The connection parameters for each subscriber can be displayed.

1. Service menu:

Press and hold **OK** +  simultaneously for approx. 4 s.

2. "Service functions"

3. **"Modbus1 subscriber"**: Subscriber list with connection status for devices connected via X18 on the controller and sensor PCB.

"Modbus2 subscriber": Subscriber list with connection status for devices connected via 241 on the controller and sensor PCB.

"KM-BUS subscriber": Subscriber list with connection status for devices connected via KM-BUS.

4. Select subscriber and display connection parameters with **OK**.

Example for **"Modbus1 subscriber"**

Refrigerant circ controller	
Subscriber add.	30
Baud rate/parity	19200/Even
Status	OK
Fault code	0x00
Timeout counter	12
Back with	

Fig. 47

Subscribers (Modbus/KM-BUS) (cont.)

Connection parameters	Modbus	KM-BUS
"Subscriber add."	Modbus 1: Predetermined for each subscriber Modbus 2: Allocated when the subscriber is commissioned.	Predetermined number of the KM-BUS subscriber
"Baud rate/parity"	Speed of the data transfer (symbols/second)/parity (even/odd/none)	—
"Device group"	—	Type of KM-BUS subscriber, e.g. remote control, mixer, etc.
"Status"	Connection status ("OK", "Fault")	
"Fault code"	Message codes for connection faults 00: Connection status "OK" is set. > 00: Connection faults: If the fault occurs repeatedly, the connection status is set to "Fault".	
"Timeout counter"	Number of failed attempts to connect to the subscriber: If the internal limit is exceeded, the fault message "EE KM-BUS subscriber" or "EF Modbus subscriber" appears (see "Messages").	

Enter Vitocom PIN code

Only for Vitocom connected to the heat pump control unit by means of a KM-BUS, e.g. Vitocom 100, type GSM2.



"Vitocom 100" installation instructions

2. "Service functions"
3. "Enter Vitocom PIN code"
4. Enter the PIN digits one by one.

1. **Service menu:**
Press **OK** and **≡** simultaneously for approx. 4 s.













Function check

1. **Service menu:**
Press **OK + ≡** simultaneously and hold for approx. 4 s.
2. "Service functions"
3. "Function check"
4. Start the required function, e.g. "DHW". Only those functions are shown that correspond to the actual system equipment level.
During the function check, the system overview is displayed: See "System overview".
5. Terminate function with **↵**.

Function check (cont.)

Function	System characteristics
"Heating circuit 1"	Secondary pump and heating circuit pump for heating/cooling circuit A1/HC1 are started.
"Heating circuit 2" "Heating circuit 3"	<ul style="list-style-type: none"> ▪ Heating circuit pump for heating/cooling circuit M2/HC2 or M3/HC3 is started. ▪ Mixer for heating/cooling circuit M2/HC2 or M3/HC3 opens/closes every 5 min.
"Cooling circuit SKK"	<p>□:</p> <ul style="list-style-type: none"> ▪ Primary pump and circulation pump in separate cooling circuit are started. ▪ Mixer for NC function opens/closes every 5 min. NC signal is activated. <p>⊗□⊗:</p> <ul style="list-style-type: none"> ▪ 4-way diverter valve switches over. ▪ Separate cooling circuit circulation pump is started.
"DHW" (DHW cylinder)	<p>The following components are started or changed over:</p> <ul style="list-style-type: none"> ▪ Secondary pump ▪ 3-way diverter valve "Central heating/DHW heating" ▪ Cylinder loading pump (DHW side)
"Swimming pool"	<ul style="list-style-type: none"> ▪ Secondary pump starts. ▪ Circulation pump for swimming pool heating and 3-way diverter valve are switched on/off every minute.
"Electr booster heater" (instantaneous heating water heater)	<ul style="list-style-type: none"> ▪ Secondary pump starts. ▪ When the minimum flow rate has been reached, stage 1 of the instantaneous heating water heater is started. ▪ Stage 2 and stage 3 of the instantaneous heating water heater are started at 30 s intervals. ▪ The instantaneous heating water heater regulates to a flow temperature of 30 °C.
"STB Electr booster heater"	<ul style="list-style-type: none"> ▪ Stage 3 of the instantaneous heating water heater is switched on. ▪ The secondary pump is not switched on. <p>The high limit safety cut-out must respond as soon as the temperature at the sensor of the capillary tube reaches 85⁻⁸ °C.</p> <ul style="list-style-type: none"> ▪ High limit safety cut-out has responded: The instantaneous heating water heater does not start with the "Electr booster heater" function. The secondary circuit flow temperature does not rise. ▪ High limit safety cut-out has not responded: The instantaneous heating water heater starts with the "Electr booster heater" function. The secondary circuit flow temperature rises.
"Heat pump"	<ul style="list-style-type: none"> ▪ Secondary pump and primary pump/fan of outdoor unit start. ▪ Compressor regulates to the set value. Compressor output is set. ▪ Secondary circuit regulates to a return temperature of 30 °C.
"Defrost" ⊗□⊗	<ul style="list-style-type: none"> ▪ The defrost function starts. ▪ The process ends if the evaporator temperature reaches the stop value.
"External heat pump"	All lag heat pumps are started for heating mode and regulated to a return temperature of 30 °C in the secondary circuit.
"External heat source"	<ul style="list-style-type: none"> ▪ The external heat generator is regulated to a flow temperature of 35 °C. ▪ External heat generator mixer opens. ▪ Heating circuit pumps are started.
With solar control module, type SM1: "Solar"	Solar circuit pump starts.

Function check (cont.)

Function	System characteristics
<p>"Primary source" </p> <p>Note This function takes approx. 10 min.</p>	<p>Not for ice store as primary source:</p> <ul style="list-style-type: none"> ▪ Primary pump starts. ▪ An average value for the primary circuit flow temperature is calculated every minute. <p>Note The temperature of the undisturbed ground is determined. If the function is terminated early, the average value calculated at the time of termination is saved.</p>
"Fan"  	<p>Fan is started.</p> <p>The following steps are repeated cyclically:</p> <ol style="list-style-type: none"> 1. The max. speed of the fan is set within 60 s. 2. The min. speed of the fan is set within 60 s.
"Cooling"  	<ul style="list-style-type: none"> ▪ Secondary pump and fan are started. ▪ Compressor regulates to the set value. Compressor output is set. ▪ Secondary circuit regulates to a flow temperature of 10 °C.
"Ice store" 	<ul style="list-style-type: none"> ▪ Absorber circuit pump starts. ▪ 3-way diverter valve changes over, so that the solar air absorber becomes the primary source. ▪ Primary pump starts.
"Vitovent ventilation"	<p>Vitovent 200-C:</p> <p>The following steps are repeated cyclically:</p> <ol style="list-style-type: none"> 1. Ventilation level  is set for 120 s. 2. Ventilation level  is set for 120 s. 3. Ventilation level  is set for 120 s. <p>Vitovent 300-F: Ventilation level  is set for 60 s. Any active bypass will be deactivated.</p> <p>The following steps are then repeated cyclically:</p> <ol style="list-style-type: none"> 1. Within 120 s, the air flow rate is increased to its maximum value and kept constant. 2. Within 120 s, the air flow rate is reduced to the min. value and kept constant. 3. The fans remain off for 30 s. <p>Note After the function check has been completed, ventilation level  is set for 60 s. Only then will the ventilation unit recommence its operation in accordance with the set operating and time program.</p>
"Vitovent heating"	<p>Vitovent 300-F:</p> <ul style="list-style-type: none"> ▪ Ventilation level  is set. ▪ The secondary pump and the heating circuit pump A1/HC1 (if installed) are started. ▪ The flow temperature in the ventilation heating circuit is set to 40 °C.

Function check (cont.)

Function	System characteristics
"Vitovent electric preheating"	<p>Vitovent 200-C:</p> <ul style="list-style-type: none"> ▪ Ventilation level $\uparrow\downarrow$ is set. ▪ The electric preheating coil is switched on and regulated to the current actual outdoor air temperature plus 10 K.
	<p>Vitovent 300-F:</p> <ul style="list-style-type: none"> ▪ Ventilation level $\uparrow\downarrow$ is set. ▪ The electric preheating coil is switched on and regulated to the current actual exhaust air temperature plus 5 K.
"Vitovent bypass"	<p>Vitovent 200-C:</p> <p>Ventilation level $\uparrow\downarrow$ is set. Any open bypass will be closed.</p> <p>The following steps are then repeated cyclically:</p> <ol style="list-style-type: none"> 1. The bypass is opened. 2. The bypass remains open for 60 s. 3. The bypass is closed. 4. The bypass remains closed for 60 s.
	<p>Vitovent 300-F:</p> <p>Ventilation level $\uparrow\downarrow$ is set for 60 s. Any open bypass will be closed.</p> <p>The following steps are then repeated cyclically:</p> <ol style="list-style-type: none"> 1. Within 60 s, the bypass is fully opened. 2. The bypass remains open for 60 s. 3. Within 60 s, the bypass is fully closed. 4. The bypass remains closed for 60 s. <p>Note</p> <p>After the function check has been completed, ventilation level $\uparrow\downarrow$ is set for 60 s. Only then will the ventilation unit recommence its operation in accordance with the set operating and time program.</p>
"Vitovent fan stop"	<p>Vitovent 300-F:</p> <p>The following components/functions of the ventilation unit are switched off:</p> <ul style="list-style-type: none"> ▪ Electric preheating coil (accessories) ▪ Supply air and exhaust air fan: If the electric preheating coil was started, the fans run on for 60 s. ▪ The bypass is closed. ▪ Supply air heating via a hydraulic reheating coil (ventilation heating circuit A1/HC1, if installed)
"Coolant buffer cylinder"	<ul style="list-style-type: none"> ▪ The 3-way diverter valves for the heating water buffer cylinder bypass are switched. ▪ All heating circuit pumps are started. ▪ Mixer for heating/cooling circuit M2/HC2 opens/closes every 5 min.

Note

Any heat generated must be transferred into the secondary circuit to prevent excessively high temperatures in the appliance. If heat is being generated with one of the functions, the secondary pump will run on for 120 s after terminating that function.

When exiting the **"Function check"** menu, the secondary pump will also be **shut down** within this run-on time.

Saving/loading settings

After a few minutes, the heat pump control unit automatically saves changed parameter settings on the coding card .

With **"Save settings"**, the saving process can be carried out manually at any time, e.g. if the coding card is subsequently removed.

With **"Load settings"**, parameter settings from the coding card can be loaded on to the control unit. This way, several devices can for example be set up identically one after the other via a coding card.

Saving settings

1. **Service menu:**
Press and hold **OK** +  simultaneously for approx. 4 s.
2. **"Service functions"**
3. **"Save settings"**.
4. **"Yes"**.

Load settings

- !** **Please note**
When loading from the coding card, **all** existing parameter settings on the control unit are overwritten.
Before loading, ensure that the heating system functions properly with the parameter settings saved on the coding card.
1. **Service menu:**
Press and hold **OK** +  simultaneously for approx. 4 s.
 2. **"Service functions"**
 3. **"Load settings"**.
 4. Start the loading process with **"Yes"**.
The control unit restarts (progress bar is shown).

Coding level 1 in the service menu

- ! Please note**
 Incorrect operation at "Coding level 1" may result in damage to the appliance and the heating system.
 Observe the installation and service instructions for the heat pump in question. Failure to do so will void your warranty rights.

Activating the service menu (setting parameters marked 1)

All parameters are displayed as plain text. A parameter code is also assigned to each parameter.

1. **Service menu:**
 Press and hold **OK** +  simultaneously for approx. 4 s.
2. **"Coding level 1"**
3. Select parameter group, e.g. **"System definition"**.
4. Select parameter, e.g. **"System scheme 7000"**.
5. Set a value, e.g. **"3"**.

If the service menu has already been activated:

1. **Extended menu:**

2. **"Service"**
3. **"Coding level 1"**

4. Select parameter group, e.g. **"System definition"**.

Note

Which parameter groups are displayed depends on the system version.

5. Select parameter, e.g. **"System scheme 7000"**.

Note

Which parameters are displayed depends on the system version.

6. Set a system scheme, e.g. **"3"**.



Please note

If the heat pump control unit is switched off at the ON/OFF switch or via a separate fuse/mains isolator, parameter settings made in the last minute may not be adopted.
 After setting parameters, wait at least 1 min before switching off the heat pump control unit.

Deactivating the service menu

- Confirm **"Terminate service?"** with **"Yes"**.
- or
- Automatic if there has been no operator action for 30 min

Setting parameters

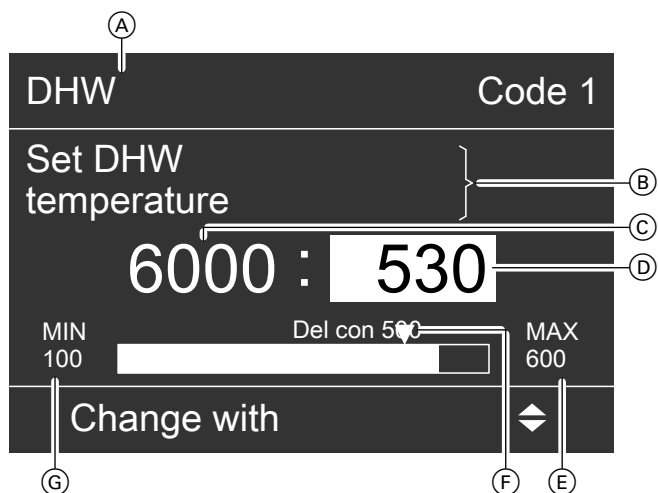

Fig. 48

- Ⓐ Parameter group
- Ⓑ Parameter description
- Ⓒ Parameter code
- Ⓓ Currently set value
- Ⓔ Upper limit of the setting range
- Ⓕ Identification of the delivered condition
- Ⓖ Lower limit of the setting range

Note

The limits of setting range Ⓔ and Ⓖ and delivered condition Ⓕ often depend on the type of heat pump. The values are displayed for almost all parameters in the heat pump control unit. Consequently values Ⓔ, Ⓕ and Ⓖ are not listed in the following parameter descriptions.

**Delivered conditions and setting ranges**

Installation and service instructions of the relevant heat pump

Bit field

Bit fields are used to specify the combination of several functions or system components with **1 parameter**. For any combination, **precisely 1** setting results.

The set value of any parameter can be determined in accordance with the following table:

Setting example

Bit	Settings for parameter "System components for external change-over 7011"	Bit significance	Setting combination 0: Not selected 1: Selected	Total
Bit 1	Heating circuit without mixer A1/HC1	1	1	1
Bit 2	Heating circuit with mixer M2/HC2	2	0	0
Bit 3	Heating circuit with mixer M3/HC3	4	0	0
Bit 4	Never adjust	8	0	0
Bit 5	DHW heating	16	1	16
Bit 6	Buffer cylinder heating	32	1	32
...	0	0
Bit N	...	2^{N-1}	0	0
Parameter set value				"49"

Setting aid

Using a setting aid, Bit 0 to Bit N can be selected from a list (multiple selections are possible). The set value of a parameter results automatically from the selected combination.

Note

Assignment of Bits to system components or functions:
See the description of the relevant parameter.

Setting parameters (cont.)

1. **Service menu and coding level are enabled. The required parameter group has been selected:**
Select parameter with a bit field: For example "System components for external changeover 7011".
2. **OK**
3. **?**
4. Select the required Bits with **OK**.
5. **"Adopt with OK"**

System definition	Code 1
Adopt with OK	
Bit 1	<input type="checkbox"/>
Bit 2	<input checked="" type="checkbox"/>
Bit 3	<input type="checkbox"/>
Change with	◄

Fig. 49

Restoring delivered condition (reset)

All parameters of the "System user" and "Contractor" setting levels (marked 1) are reset.

1. **Service menu:**
Press and hold **OK** +  simultaneously for approx. 4 s.
2. **"Coding level 1"**
3. **"Standard setting"**
4. **"All groups"**
or
Select the required parameter group, e.g. **"System definition"**.

Note

All parameters for the "Contractor" and "System user" setting levels are described below.
Parameters assigned to the "System user" setting level can be set by the system user via a menu.
For differentiation, parameters assigned to the "Contractor" setting level are marked with 1.

Calling up the parameter group

1. **Service menu:**
Press **OK** + **≡**: simultaneously and hold for approx. 4 s.
2. **"Coding level 1"**
3. **"System definition"**
4. Select parameter.

7000 System scheme 1

Set the system scheme during commissioning according to the system version. 12 different system schemes are available.

The components (X) associated with the selected system scheme are automatically activated and monitored.

Vitocal 111-S/222-A/222-S: Notes regarding the installation kit with mixer ("Type of assembly kit 7044" set to "1")

The following system components are not monitored, even if this is shown in the system scheme:

- Buffer cylinder in the secondary circuit flow
- Heating circuit M3/HC3 (central heating and cooling)
- Separate cooling circuit

System schemes

Component	System scheme											
	0	1	2	3	4	5	6	7	8	9	10	11
Heating circuit												
A1/HC1	—	X	X	—	—	X	X	—	—	X	X	—
M2/HC2	—	—	—	X	X	X	X	X	X	X	X	—
M3/HC3	—	—	—	—	—	—	—	X	X	X	X	—
DHW cylinder	X	—	X	—	X	—	X	—	X	—	X	—
Immersion heater	○	—	○	—	○	—	○	—	○	—	○	—
Heating water buffer cylinder	—	○	○	X	X	X	X	X	X	X	X	—
Heating water/coolant buffer cylinder	—	○	○	○	○	○	○	○	○	○	○	—
External heat generator	○	○ ^{*3}	○ ^{*3}	○	○	○	○	○	○	○	○	—
Instantaneous heating water heater	○	○	○	○	○	○	○	○	○	○	○	○
Swimming pool	—	○	○	○	○	○	○	○	○	○	○	—
Solar thermal system	○	—	○	—	○	—	○	—	○	—	○	—
Cooling												
A1/HC1	—	○	○	—	—	○	○	—	—	○	○	—
M2/HC2	—	—	—	○	○	○	○	○	○	○	○	—
M3/HC3	—	—	—	—	—	—	—	○	○	○	○	—
Separate cooling circuit SKK	○	○	○	○	○	○	○	○	○	○	○	—
Ice store and solar air absorber	○	○	○	○	○	○	○	○	○	○	○	○
Energy meter	○	○	○	○	○	○	○	○	○	○	○	—
Ventilation unit	○	○	○	○	○	○	○	○	○	○	○	—

- X Component selected
- Component can be added via the associated parameters.

Detailed information regarding system examples:
www.viessmann-schemes.com

Note

Set **system scheme 11** for the lag heat pumps in a heat pump cascade.

^{*3} Only in conjunction with a heating water buffer cylinder.

7002 Interval for long term average outside temperature 1

Averaging interval for calculating the adjusted outside temperature (long term average).

This outside temperature is for example used for:

- Calculating the set flow temperature from heating or cooling curve
- Changeover between central heating and central cooling mode

The continuous averaging of actual temperatures reduces the influence of brief temperature fluctuations. The mathematical method applied acts like an attenuation. With this attenuation, the adjusted outside temperature achieves the following values after a sudden temperature change:

- 63 % of the change after a single averaging interval
- 95 % of the change after three averaging intervals

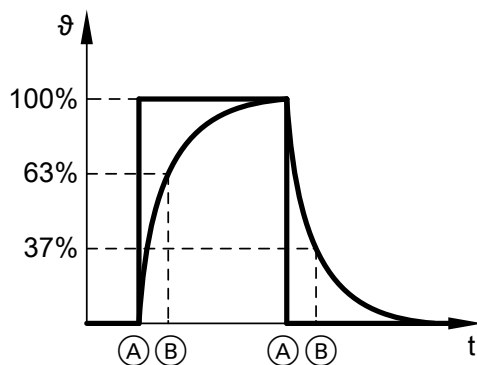

Fig. 50

- Ⓐ Time of the sudden temperature change
- Ⓑ Expiry of one averaging interval

In practical use, this characteristic results not only in an adjustment but also a delay in capturing the outside temperature.

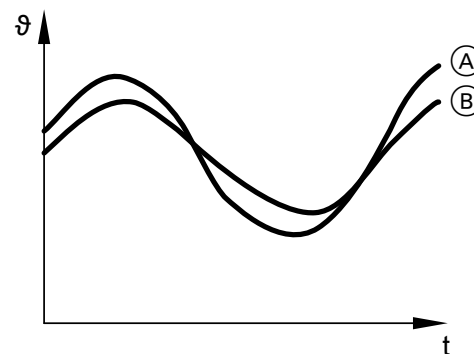

Fig. 51

- Ⓐ Outside temperature (not adjusted)
- Ⓑ Adjusted outside temperature

Note

For other functions, the control unit calculates a short-term average outside temperature (averaging interval 2 min).

Setting in min

7003 Temperature differential for calculating the heating limit 1

Heating limit:

Set room temperature minus "Temperature differential for calculating the heating limit 7003".

Central heating starts automatically if the adjusted outside temperature (long term average, averaging interval in the delivered condition 3 h) falls below the heating limit. The operating program "Heating and DHW" must be active.

Example:

Selected set room temperature = 20 °C

"Temperature differential for calculating the heating limit 7003" = 4 K

This results in a heating limit of 16 °C (20 °C – 4 K).

- Adjusted outside temperature < 16 °C (heating limit): Central heating starts.
- Adjusted outside temperature > 18 °C (due to specified hysteresis of 2 K): Central heating is stopped.

7003 Temperature differential for calculating... (cont.)

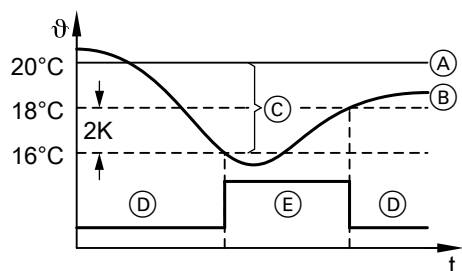

Fig. 52

- (A) Set room temperature
- (B) Adjusted outside temperature (long term average)
- (C) Set value "Temperature differential for calculating the heating limit"
- (D) Heating mode OFF
- (E) Heating mode ON

Setting 1 \triangleq 0.1 K

7004 Temperature differential for calculating the cooling limit

Cooling limit:

Set room temperature plus "Temperature differential for calculating the cooling limit 7004".

Central cooling starts automatically if the adjusted outside temperature (long term average, averaging interval in the delivered condition 3 h) exceeds the cooling limit. The operating program "Heating/cooling and DHW" must be active.

Note

The cooling limit has no effect on a separate cooling circuit.

This parameter is only available if cooling mode was enabled by means of parameter "Cooling function 7100".

Setting 1 \triangleq 0.1 K

Example:

Set room temperature = 20 °C

"Temperature differential for calculating the cooling limit 7004" = 4 K

This results in a cooling limit of 24 °C (20 °C + 4 K).

- Adjusted outside temperature > 24 °C (cooling limit):
Central cooling starts.
- Adjusted outside temperature < 23 °C (due to specified hysteresis of 1 K):
Central cooling is stopped.

7007 Primary pump for natural cooling

Primary pump switching state if natural cooling is ON. This setting depends on the installed system components.

Value	Meaning
"0"	The primary pump will not start in the case where heat is being transferred via another system component, such as a heating coil. Pumps that may be required can be switched via the NC signal (contact 211.5 on the main PCB).
"1"	Primary pump starts if heat is being transferred via the primary circuit, for example.

7008 Swimming pool 1

Swimming pool heating control via temperature controller for regulating swimming pool temperature (accessory).

Value	Meaning
"0"	No swimming pool heating.
"1"	Swimming pool heating.

Note

The temperature controller for regulating the swimming pool temperature is connected to the heat pump control unit via extension EA1 ("**External extension 7010**").

700A Cascade control 1   / 

Value	Meaning
"0"	No cascade control
"1"	Do not adjust.
"2"	Cascade control via LON Note Do not set for heat pump compact appliances.
"3"	Do not adjust.

Notes

- For the lead heat pump, set "2".
- For lag heat pumps, set this value to "0" and "System scheme 7000" to "11".

700C Use of heat pump in cascade 1   / 

For cascade control via LON: Setting at **each lag heat pump** in the cascade. This makes it possible to enable individual lag heat pumps for different purposes.

Example:

With cascade control via LON, one heat pump can be used to provide only central heating and another to provide only DHW heating.
Setting in the bit field (see chapter "Setting parameters"): Several bits can be selected.

Note

? opens the setting assistant.

Bit	Meaning
"Bit 1"	DHW heating
"Bit 2"	Central heating
"Bit 3"	Central cooling
"Bit 4"	Swimming pool heating

The setting results from the combination of selected bits.

700D Runtime balance cascade 1   / 

Runtime balance ensures that the compressor run-times of the heat pumps in a cascade are as similar as possible.

Value	Meaning
"0"	No runtime balance
"1"	Runtime balance between lead heat pump and all lag heat pumps: The runtimes are determined from the hours run saved to the heat pump control unit: " Diagnosis " ▶ " Heat pump " ▶ " Hours run compressor " ▶

700F Output control strategy, cascade 1   / 

Only for output-dependent controlled heat pumps:

700F Output control strategy, cascade 1 / (cont.)

To control the output of the heat pump cascade the flow temperature in the secondary circuit is captured.

Value	Meaning
"0"	No output control
"1"	Never adjust
"2"	Output control via the buffer outlet temperature sensor

7010 External extension 1

Areas of application for EA1 extension:

- Swimming pool heating
- External changeover of the operating status
- External demand/external mixer OPEN or control function
- External blocking/external mixer CLOSE or control function
- Defaulting the set flow temperature in the case of external demand by analogue voltage signal 0 to 10 V
- Minimum heating water temperature (secondary circuit flow temperature)
- Smart Grid

Note

For swimming pool heating, the following functions **cannot** be achieved:

- External changeover of the operating status
- External demand to the heat pump/external mixer OPEN

Note

With Smart Grid, the following functions **cannot** be achieved:

- External changeover of the operating status
- External demand
- External blocking

Areas of application for AM1 extension:

- Central fault message
- Changeover of primary source in conjunction with ice store

Setting in the bit field (see chapter "Setting parameters"): Several bits can be selected.

Note

? opens the setting assistant.

Bit	Meaning
"Bit 1"	EA1 extension
"Bit 2"	AM1 extension
"Bit 3"	Do not adjust.

The setting results from the combination of selected bits.

7011 System components for external changeover 1

Selection of system components for which the operating status should be changed for a certain period of time. With a ventilation unit, the ventilation level is changed.

- Heating circuits, DHW heating, buffer cylinder:
The operating status to be selected is specified by parameter "**Operating status for external changeover 7012**".
- Ventilation:
The ventilation level to be set is specified with parameter "**Effect of OM changeover to ventilation 701F**".
- The duration of the changeover is specified by parameter "**Duration of external changeover 7013**".

Note

The function "**Effect of external demand on heat pump/heating circuits 7014**" has a higher priority than the function "**System components for external changeover 7011**".

Setting in the bit field (see chapter "Setting parameters"): Several bits can be selected.

Note

? opens the setting assistant.

Bit	Meaning
"Bit 1"	Heating circuit without mixer A1/HC1
"Bit 2"	Heating circuit with mixer M2/HC2
"Bit 3"	Heating circuit with mixer M3/HC3

7011 System components for external changeover 1 (cont.)

Bit	Meaning
"Bit 4"	Never adjust
"Bit 5"	DHW heating
"Bit 6"	Buffer cylinder
"Bit 7"	Connected ventilation unit

The setting value results from the combination of selected bits.

7012 Operating status for external changeover 1

Selecting the operating status to be switched to via external changeover.

Value	Operating status (see operating instructions)		
	Heating/cooling	DHW	Buffer cylinder
"0"	No heating, only frost protection for the selected system components		
"1"	"Reduced"	"Top"	"Top"
"2"	"Standard"	"Standard"	"Standard"
"3"	"Fixd value": Set flow temperature is "Max. flow temperature heating circuit 200E".	"Temp. 2": Heating to "Set DHW temperature 2 600C"	"Fixd value": Heating to "Temp in operating status fixed value for buffer cyl 7202"

Note

If "Bit 7" is set under "System components for external changeover 7011": The ventilation level that is to be activated externally is specified with "Effect of OM changeover to ventilation 701F".

7013 Duration of external changeover 1

Minimum duration of external changeover of the operating status. The operating status is changed over as soon as the switching contact is closed (signal present).

Example: Value for the changeover duration B 8 h (delivered condition)

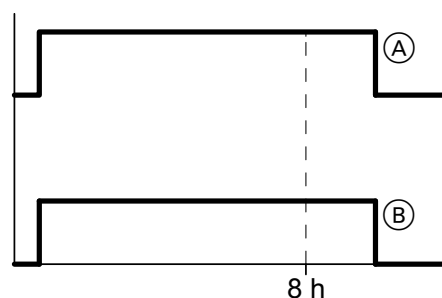
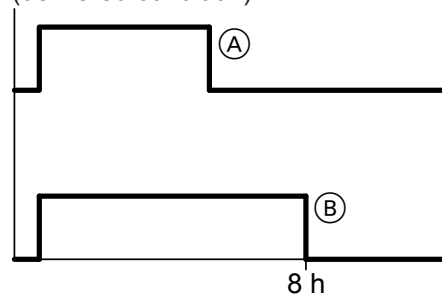

Fig. 53

7013 Duration of external changeover 1 (cont.)

- Signal duration (A) < value for duration of the changeover (B):
Duration of changeover 8 h
- Signal duration (A) > value for duration of the changeover (B):
Duration of changeover = Duration of signal

Value	Duration
"0"	Changeover only as long as the switching contact is closed
"1" "12"	Minimum changeover duration: The duration commences as soon as a signal is present.

Setting in h

7014 Effect of external demand on heat pump/heating circuits 1

Setting on which the function "External demand/External mixer OPEN" should have an effect.

- Note**
- With "External demand", a specific set flow temperature is set for the secondary circuit ("**Flow temperature for external demand 730C**").
 - The "External blocking" signal has a higher priority than the "External demand" signal.

Value	Heating circuit with mixer M2/HC2	Heating circuit with mixer M3/HC3	Heat demand to heat pump
"0"	Control mode	Control mode	No
"1"	Mixer "OPEN"	Control mode	No
"2"	Control mode	Mixer "OPEN"	No
"3"	Mixer "OPEN"	Mixer "OPEN"	No
"4"	Control mode	Control mode	Yes
"5"	Mixer "OPEN"	Control mode	Yes
"6"	Control mode	Mixer "OPEN"	Yes
"7"	Mixer "OPEN"	Mixer "OPEN"	Yes

Note
For swimming pool heating, the heat demand of the heat pump must be enabled (setting "4", "5", "6" or "7").

7015 Effect of ext. blocking on heat pump/heating circuits 1

Effect of function "External blocking/external mixer CLOSE" on the system components

- Note**
The "External blocking" signal has a higher priority than the "External demand" signal.

! **Please note**
The system may no longer be protected against frost, if "External blocking" is active.
Ensure frost protection on site.

Value	Heating circuit with mixer M2/HC2	Heating circuit with mixer M3/HC3	Heat pump blocking
"0"	Control mode	Control mode	No
"1"	Mixer "CLOSED"	Control mode	No
"2"	Control mode	Mixer "CLOSED"	No
"3"	Mixer "CLOSED"	Mixer "CLOSED"	No
"4"	Control mode	Control mode	Yes

7015 Effect of ext. blocking on heat... (cont.)

Value	Heating circuit with mixer M2/HC2	Heating circuit with mixer M3/HC3	Heat pump blocking
"5"	Mixer "CLOSED"	Control mode	Yes
"6"	Control mode	Mixer "CLOSED"	Yes
"7"	Mixer "CLOSED"	Mixer "CLOSED"	Yes

7017 Vitocom 100 1

Use of the communication interface Vitocom 100, type GSM.

Value	Meaning
"0"	Vitocom 100, type GSM is not used.
"1"	Vitocom 100, type GSM is installed and active.

7018 Temperature range input 0..10V 1

Temperature range for DC voltage signal 0 to 10 V. The range starts at 0 °C and continues linearly to the set value.

This signal can, for example, be used to specify the secondary circuit set flow temperature **for central heating** in the case of external demand. For this, connect the voltage signal at input "0–10 V" of the EA1 extension.

Example:

A value of 800 results in a temperature range of 0 to 80 °C, i.e. 5 V correspond to 40 °C and 7.5 V to 60 °C.

Setting 1 \pm 0.1 °C

7019 Priority external demand 1

Priority of external demand relative to the demands for heating or cooling mode

Note

Priority over DHW heating must be set separately.

Value	Meaning
"0"	Low priority: Central heating/cooling takes priority over external demand.
"1"	High priority: External demand takes priority over central heating/cooling.
"2"	Never adjust
"3"	Never adjust

701A Effect of external blocking on pumps/compressor 1

Selection of working parts, e.g. secondary pump/compressor

! **Please note**
The system may no longer be protected against frost, if "External blocking" is active. Ensure frost protection on site.

Note

- Observe setting for parameter "**Effect of ext. blocking on heat pump/heating circuits 7015**".
- The "External blocking" signal has higher priority than the "External demand" signal.

Setting in the bit field (see chapter "Setting parameters"): Several bits can be selected.

701A Effect of external blocking on... (cont.)

Note

? opens the setting wizard.

Bit	Meaning
"Bit 1"	Heating circuit pump A1/HC1 blocked
"Bit 2"	Heating circuit pump M2/HC2 blocked
"Bit 3"	Heating circuit pump M3/HC3 blocked

Bit	Meaning
"Bit 4"	Circulation pump for cylinder heating blocked
"Bit 5"	Secondary pump/compressor blocked

The setting value results from the combination of selected bits.

701B Common flow temperature sensor system 1

In systems with a buffer cylinder, a common flow temperature sensor can be installed in the heating water flow, downstream of the buffer cylinder.

Note

If no system flow temperature sensor is installed, observe the following:

- No frost protection monitoring for heating circuit A1/HC1
- Mixer external heat source (if installed) does not open.

Value	Meaning
"0"	System flow temperature sensor is not used. Flow temperature sensor in secondary circuit is used.
"1"	System flow temperature sensor is installed and enabled. Note If an external heat generator is set (" Enable external heat source 7B00 " set to "1"), this value is set automatically.

701C Operating status after message A9, C9 1

The heat pump will be blocked from operating if fault messages A9 or C9 are issued. Central heating and DHW heating will then be provided with the available booster heaters, such as the instantaneous heating water heater. The compressor will only start again once the fault has been remedied and the heat pump has been switched OFF and ON again once. In this parameter the conditions for the operation with booster heaters can be set.

Value	Meaning
"0"	<ul style="list-style-type: none"> ▪ Central heating with "Standard room temperature 2000" less 5 K ▪ Set DHW temperature 30 °C ▪ Recommended setting if the instantaneous heating water heater is used.
"1"	<ul style="list-style-type: none"> ▪ Central heating and DHW heating in accordance with the set time programs ▪ Recommended setting if an external heat generator is used, such as an oil condensing boiler.

701F Effect of OM changeover to ventilation 1

Ventilation level that is set with external changeover. Requirement: Ventilation unit is selected for external changeover. For this, select "**Bit 7**" under "**System components for external changeover 7011**".

Note

? opens the setting wizard.

Bit	Ventilation level
"Bit 0"	OFF
"Bit 1"	Background ventilation
"Bit 2"	Reduced ventilation

Bit	Ventilation level
"Bit 3"	Nominal ventilation
"Bit 4"	Intensive ventilation

Note

If under "**System components for external changeover 7011**" another Bit is selected alongside "**Bit 7**": The operating status to be switched to by external changeover is specified with "**Operating status for external changeover 7012**".

701F Effect of OM changeover to ventilation 1 (cont.)

The setting value results from the combination of selected bits.

7029 Number of lag heat pumps 1 /

Number of lag heat pumps with cascade control via LON

Value	Meaning
"0"	No lag heat pump
"1" to "4"	Number of lag heat pumps

7030 Select primary source 1

Value	Meaning
"0"	Geothermal collectors/geothermal probes
"1"	Ice store or solar air absorber <i>Note</i> <i>AM1 extension and Vitosolic 200 are required for ice stores. Therefore observe "External extension 7010" and "Type solar control unit 7A00".</i>

7031 Start hysteresis solar air absorber 1

The solar air absorber is only used as a primary source if the differential between the absorber and ice store temperature is **greater** than the set value.

Setting 1 \cong 0.1 K

Other prerequisites:

- Absorber temperature > **"Minimum temp. for solar absorber primary source 7033"**
- Primary inlet temperature is within the valid range.

7032 Solar absorber hysteresis 1

Hysteresis for starting and stopping the solar air absorber as primary source, relative to the set limits for the primary inlet temperature. This starts the primary source ice store prior to the limits for the primary inlet temperature being reached and the compressor shuts down.

- Absorber temperature > **"Min. inlet temperature primary circuit 5016"** plus **"Solar absorber hysteresis 7032"**
- Absorber temperature < **"Max. inlet temperature primary circuit 5015"** minus **"Solar absorber hysteresis 7032"**

Conditions for using the solar air absorber as primary source:

Setting 1 \cong 0.1 K

- Temperature differential solar air absorber – ice store > **"Start hysteresis solar air absorber 7031"**
- Absorber temperature > **"Minimum temp. for solar absorber primary source 7033"**

7033 Minimum temp. for solar absorber primary source

The solar air absorber is only used as the primary source if the absorber temperature **exceeds** the set value.

Setting 1 \pm 0.1 °C

Conditions for using the solar air absorber as primary source:

- Temperature differential solar air absorber – ice store > **"Start hysteresis solar air absorber 7031"**
- Absorber temperature > **"Minimum temp. for solar absorber primary source 7033"**
- Primary inlet temperature is within the valid range.

7034 Average ground temperature in summer mode

Max. temperature ice store in summer mode: See **"Min. runtime to suppress summer mode 7035"**. Set this value lower than max. primary inlet temperature minus **"Solar absorber hysteresis 7032"**.

Note
The max. primary inlet temperature can only be changed by a heat pump installer certified by Viessmann.

Setting 1 \pm 0.1 °C

7035 Min. runtime to suppress summer mode

Particularly in summer, high temperatures in the ice store lead to heat losses to the ground and consequently to frequent reheating via the solar air absorber. To avoid this, the maximum temperature of the ice store is reduced in summer mode.

Setting in min

Summer mode is switched on under the following conditions:

- On a single day, the heat pump was operating to provide central heating for **less** than the **"Min. runtime to suppress summer mode 7035"** in operation.
- **"Calendar week, start summer mode, ice store 7039"** has been reached.
- The **"Last calendar week for summer mode 7036"** has not yet been reached.

7036 Last calendar week for summer mode

After the set calendar week, summer mode is no longer switched on. The ice store is heated up to the maximum temperature via the solar air absorber.

Setting in calendar weeks

7037 Absorber circuit monitoring

Value	Meaning
"0"	Monitoring OFF
"1"	If the amount of energy with active switching of the absorber pump falls below 1 kWh within a 6 h period, the fault message "96 Ice store absorber circ" will be displayed. Condition: A heat meter is installed in the absorber circuit.

7038 Temperature sensor for dual mode operation

Value	Meaning
"0"	Outside temperature sensor is used: Dual mode operation if long term average falls below outside temperature "Dual mode temperature external heat source 7B02" .
"1"	Ice store temperature sensor is used: Dual mode alternative operation if temperature in the ice store falls below "Dual mode temperature external heat source 7B02" .

7039 Calendar week, start summer mode, ice store

Summer mode is not switched on before the set calendar week. The ice store is heated up to the maximum temperature via the solar air absorber.

Setting in calendar weeks

703A Calendar week, earliest end summer mode, ice store

Summer mode ends if, on a single day after the set calendar week, the heat pump was operating to provide central heating for **more** than the **"Min. runtime to suppress summer mode 7035"**. The ice store is heated up to the maximum temperature via the solar air absorber.

Summer mode finally ends for the current year after **"Last calendar week for summer mode 7036"**.

Setting in calendar weeks

Summer mode is switched on again if, on a single day, the heat pump was operating to provide central heating for **less** than the **"Min. runtime to suppress summer mode 7035"**.

7044 Type of assembly kit

Vitocal 111-S/222-A/222-S:

If an installation kit with mixer is installed, heating circuit M2/HC2 is **directly** connected to the heat pump. The heating circuit pump and heating circuit mixer are part of the installation kit. A buffer cylinder in the secondary circuit flow is not connected.

7044 Type of assembly kit 1   (cont.)

Notes regarding the installation kit with mixer ("Type of assembly kit 7044" set to "1")

- Heating circuit A1/HC1 must be connected, otherwise heating circuit M2/HC2 cannot be supplied with heat.
- Set the rated output of the heating circuit pump **"Rated output heating circuit pump HC2 734A"** in accordance with the required flow rate in heating circuit M2/HC2.
- It is not possible to operate a buffer cylinder in the secondary circuit flow.
- In conjunction with the installation kit with mixer, a sufficient system volume must be available in order to provide the defrost energy. For this, either install an overflow valve at the furthest point in the heating circuit or a heating water buffer cylinder with a low volume in the secondary circuit return.

Value	Meaning
"0"	Installation kit with mixer is not installed.
"1"	Installation kit with mixer is installed. The following system components are not monitored, even if this is shown in the system scheme: <ul style="list-style-type: none"> ▪ Buffer cylinder in the secondary circuit flow: "Enable buffer cylinder/low loss header 7200" has no effect ▪ Heating circuit M3/HC3 (central heating and cooling) ▪ Separate cooling circuit

7050 Holiday program effect 1

Functions **not** affected by the holiday program. Setting in the bit field (see chapter "Setting parameters"): Several bits can be selected.

Note
? opens the setting assistant.

Bit	Meaning
"Bit 1"	DHW heating
"Bit 2"	DHW heating with "Set DHW temperature 2"
"Bit 3"	Buffer cylinder heating
"Bit 4"	Ventilation
"Bit 5"	Central heating/central cooling via heating circuit A1/HC1

Bit	Meaning
"Bit 6"	Central heating/central cooling via heating circuit M2/HC2
"Bit 7"	Central heating/central cooling via heating circuit M3/HC3
"Bit 8"	Central cooling via separate cooling circuit SKK
"Bit 9"	DHW circulation pump

Note
If no bit has been selected, the holiday program will affect **all** functions.

The setting value results from the combination of selected bits.

Calling up the parameter group

1. **Service menu:**
Press **OK** + simultaneously and hold for approx. 4 s.
2. **"Coding level 1"**
3. **"Compressor"**
4. Select parameter.

5000 Enable compressor /

Enabling of the compressor for operation of the heat pump or of heat pump stage 1.

Note

For heat pumps with a 2-stage refrigerant circuit, the compressors must **"additionally"** be enabled with the parameter **"Enable compr stage for tandem operation 509E"**.

Note for !

To switch the compressor off, set parameter **"Enable use of compressor stage 5012"** to **"0"**.

Note

To block the heat pump when drying a building, use parameter **"Heat pump for drying a building 7300"**.

Value	Meaning
"0"	Compressor does not start.
"1"	Compressor is enabled.

5010 Evaporator temperature for defrost end /

The defrost process ends if the evaporator temperature exceeds the set value.

Setting value $1 \pm 0.1 \text{ }^\circ\text{C}$

Note

- This parameter has no effect with the Vitocal 100-S/111-S.
- To protect the condenser from freezing, the heat pump control unit includes other functions that can terminate evaporator defrosting early.

5012 Enable use of compressor stage

Enabling the use of the compressor:

- For a single stage heat pump
- For heat pumps with 2-stage refrigerant circuit for compressor 1

Note

The use of compressor 2 is enabled via **"Enable compr 2 for hydraulic circuit 509F"**.

Setting in the bit field (see chapter "Setting parameters"): Several bits can be selected.

Bit	Meaning
"Bit 1"	DHW heating
"Bit 2"	Central heating
"Bit 3"	Central cooling
"Bit 4"	Swimming pool heating

Note

The compressor will not start if no bit has been selected.

Note

opens the setting assistant.

The setting value results from the combination of selected bits.

Parameter group Compressor

5030 Output compressor stage 1

Type-dependent heating output of the heat pump or compressor 1 in a 2-stage refrigerant circuit:
This value is required to calculate the energy statement and seasonal performance factor, for example.

Example:

Vitocal 200-S, type AWB-M-E-AC 201.D08: Rated heating output 8 kW

Note

: Set the output in line with the connected outdoor unit. If the output is not specified, the heat pump does **not** start. A fault with fault code **"B0"** is displayed in the message history on the heat pump control unit.



Setting in kW

5043 Primary source output 1

Output of the primary circuit actuators, e.g. primary pump.
This value is required to calculate the energy statement and seasonal performance factor.

Note

With setting **"0"**, an output value of 7.5 % of the compressor output is used internally.

Type	Meaning
<input type="checkbox"/>	Total of the rated outputs of all primary and well pumps used: See type plates of the circulation pumps used.
 <input type="checkbox"/>	Rated fan output, set at the factory: Does not apply to heat pumps with refrigerant circuit controller [6] .
 <input type="checkbox"/>	Do not adjust.

Setting in W

509E Enable compr stage for tandem operation 1

Enabling the compressors in a 2-stage refrigerant circuit.
Condition: **"Enable compressor 5000"** is set to **"1"**.

Value	Meaning
"0"	Both compressors are blocked.
"1"	Compressor 1 is enabled.
"2"	Compressor 2 is enabled.
"3"	Compressor 1 and compressor 2 are enabled.

509F Enable compr 2 for hydraulic circuit 1

Enabling the use of compressor 2 in a heat pump with 2-stage refrigerant circuit.

Note

The use of compressor 1 is enabled with parameter **"Enable use of compressor stage 5012"**.

Setting in the bit field (see chapter "Setting parameters"): Several bits can be selected.

Note

 opens the setting assistant.

Note

The compressor will not start if no bit has been selected.

The setting value results from the combination of selected bits.

Bit	Meaning
"Bit 1"	DHW heating
"Bit 2"	Central heating
"Bit 3"	Room cooling
"Bit 4"	Swimming pool heating

Calling up the parameter group

1. **Service menu:**
Press **OK** + **≡**: simultaneously and hold for approx. 4 s.
2. **"Coding level 1"**
3. **"External heat source"**
4. Select parameter.

7B00 Enable external heat source 1

The external heat source can be activated by the heat pump control unit if the heat demand requires this.

Note

All other parameters for the external heat source are only visible if this parameter is set to "1".

Value	Meaning
"0"	External heat source is not in use.
"1"	External heat source, e.g. oil condensing boiler, is activated. Note <i>This setting simultaneously activates the system flow temperature sensor. The parameter "Common flow temperature sensor system 701B" is set to "1".</i>

7B01 Priority ext. heat source/instant. heating water heater 1

Only applies to central heating.

Value	Meaning
"0"	Instantaneous heating water heater has priority.
"1"	External heat source has priority.

7B02 Dual mode temperature external heat source 1

If the adjusted outside temperature (long term average) falls below the value set here for an extended period, the external heat generator will start in line with demand. Depending on the primary source, either the adjusted outside temperature (long-term average) or the temperature in the ice store is decisive for this ("**Temperature sensor for dual mode operation 7038**").

Requirements:

- The heat pump and/or other heat sources cannot meet the current heat demand on their own.
- Dual mode parallel operation is set: "**Dual mode heat pump operation 7B0E**" is set to "1".

Above the dual mode temperature, the heat pump control unit only starts the external heat generator under the following conditions:

- DHW reheating with the external heat generator is required ("**Enable external heat source for DHW heating 7B0D**").
- Heat pump is faulty.
- Heat pump is blocked, e.g. during the power-OFF periods.

Setting 1 \pm 0.1 °C

Parameter group External heat source

7B03 Start threshold external heat source 1

To prevent the external heat generator starting immediately if the set flow temperature in the secondary circuit is not reached for a short time, the control unit uses the output integral as start criteria. This output integral is the integral from duration and extent of the deviation of the set flow temperature to the actual value. In fig 54, the output integral is the grey area between the time line of the actual value and the hysteresis of the flow temperature secondary circuit.

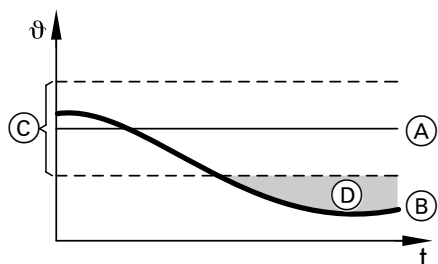

Fig. 54

- Ⓐ Set flow temperature, secondary circuit
- Ⓑ Secondary circuit flow temperature actual value
- Ⓒ Hysteresis, flow temperature secondary circuit
- Ⓓ Output integral

Setting in K·min

7B04 Start delay external heat source 1

The external heat generator does not start within the specified period following a change of the set flow temperature in the secondary circuit. This may occur for example during a change in operating status in the time program ("Standard", "Reduced", "Fixed value") or following a changeover between central heating and DHW heating.

Setting in min

7B05 Min. flow temperature mixer external heat source ON 1

The following components for the hydraulic connection of the external heat generator will only be switched when the boiler water temperature has reached the set value. This prevents cold heating water from entering the system flow or the DHW cylinder.

- Central heating: External heat generator mixer opens.
- DHW heating: Circulation pump for cylinder reheating starts.

If the boiler water temperature falls below the set value, the mixer will be closed, and the circulation pump for cylinder reheating is switched off.

Setting $1 \pm 0.1 \text{ } ^\circ\text{C}$

7B06 Min. runtime external heat source 1

Following a demand, the control unit will not switch the heat generator off within this time (demand signal at terminals 222.3/222.4 'live').

Setting in min

7B07 Run-on time external heat source 1

When the demand for the external heat generator is no longer present, the external heat generator initially remains on. The external heat generator is only switched off when the system flow temperature has reached the set value for the duration set here.

 Setting in min

7B0B Max. excess flow temp external heat source 1

Excess flow temperature of external heat generators compared to the required set system flow temperature. A slightly higher flow temperature of the external heat generator compensates for possible small mixer leaks.

Note

A negative value reduces the value of "Min. flow temperature mixer external heat source ON 7B05".

 Setting 1 \pm 0.1 K

7B0C Enable external heat gen. for central heating 1

If the heat pump cannot cover the heat demand from the heating circuits, the external heat generator is started. If the boiler water temperature is sufficiently high, the boiler water will be supplied to the heating circuits via the mixer for external heat generators (downstream of the buffer cylinder). This mixer regulates to the set flow temperature of the system.

Value	Meaning
"0"	External heat source is blocked for central heating.
"1"	External heat source is enabled for central heating.

Other conditions for central heating with an external heat source:

- The dual mode temperature is not reached.
- Or**
- There is a special heat demand, e.g. frost protection of a system component.

7B0D Enable external heat source for DHW heating 1

If the heat pump cannot cover the heat demand from the DHW cylinder, the circulation pump for DHW reheating and the external heat generator will be activated.

Note

*If an immersion heater is installed in the DHW cylinder and is controlled via the heat pump control unit, the external heat generator **cannot** be used for DHW reheating.*

Value	Meaning
"0"	External heat generator is blocked for DHW heating.
"1"	External heat generator is enabled for DHW heating.

7B0E Dual mode heat pump operation 1

Only applies to central heating.

Value	Meaning
"0"	Dual mode alternative operation for heating systems with buffer cylinder: If the adjusted outside temperature (long term average) lies above the " Dual mode temperature external heat source 7B02 ", central heating will only be provided by the heat pump, below this it will only be provided by the external heat source.
"1"	Dual mode parallel operation for heating systems with buffer cylinder: If the adjusted outside temperature (long term average) lies below the " Dual mode temperature external heat source 7B02 ", the external heat generator can start in addition to the heat pump. The heat pump stops at outside temperatures below " Shutdown limit, heat pump dual mode 7B0F ".
"2"	Dual mode alternative operation for heating systems without buffer cylinder and with only 1 heating circuit without mixer: If the adjusted outside temperature (long term average) lies above the " Dual mode temperature external heat source 7B02 ", central heating will only be provided by the heat pump, below this it will only be provided by the external heat source.

Information on setting "0" and "1"

In order to prevent the buffer cylinder being heated via the return of the external heat generator, route the heating circuit return via a 3-way diverter valve directly into the external heat generator. Connect the 3-way diverter valve to 212.4 on the main PCB.

Note

For DHW heating, a demand to the external heat generator in parallel to the heat pump is also made above the dual mode temperature: See "**Dual mode temperature external heat source 7B02**".

7B0F Shutdown limit, heat pump dual mode 1

If the adjusted outside temperature (long-term average) falls below this temperature limit, central heating and DHW heating are carried out by the external heat source alone, even with dual mode parallel operation (for DHW heating, set "**Enable external heat source for DHW heating 7B0D**" to "1").

Note

- This value should always be set lower than "**Dual mode temperature external heat source 7B02**".
- The setting -50 °C switches off this function.

Setting $1 \pm 0.1\text{ °C}$

7B10 Enable min. temp. maintenance for ext. HS 1

The following components for the hydraulic connection of the external heat generator will only be switched when the boiler water temperature of the external heat generator has reached "**Min. flow temperature mixer external heat source ON 7B05**". This prevents cold heating water from entering the system flow or the DHW cylinder.

- Central heating:
External heat generator mixer opens.
- DHW heating:
Circulation pump for cylinder reheating starts.

The characteristics of these components can be determined with the following settings, if the boiler water temperature **during** the existing demand for the external heat generator falls below the "**Min. flow temperature mixer external heat source ON 7B05**".

7B10 Enable min. temp. maintenance for ext. HS 1 (cont.)

Value	Meaning
"0"	Mixer remains open and the circulation pump for cylinder reheating remains ON.
"1"	Mixer closes. Circulation pump for cylinder reheating is switched off. The components will be switched again if the boiler water temperature exceeds the "Min. flow temperature mixer external heat source ON 7B05" again.

7B11 Enable boiler water temperature sensor 1

Value	Meaning
"0"	The boiler water temperature sensor of the external heat source is not used by the heat pump control unit.
"1"	The boiler water temperature sensor of the external heat source is connected to the heat pump control unit and can be used.

Calling up the parameter group

1. **Service menu:**
Press **OK** +  simultaneously and hold for approx. 4 s.
2. **"Coding level 1"**
3. **"DHW"**
4. Select parameter.

6000 Set DHW temperature

Set cylinder temperature for operating status **"Top"** and **"Standard"** in the DHW time program: DHW heating ends when this temperature is reached in the DHW cylinder.

Setting 1 \pm 0.1 °C



Operating status

"Vitotronic 200" operating instructions

If the set DHW temperature cannot be achieved with the heat pump, the following booster heaters can be activated in addition to the heat pump for DHW reheating:

- Instantaneous heating water heater ("**Enable electric heaters for DHW heating 6015**")
- Immersion heater ("**Enable booster heaters for DHW heating 6014**", "**Enable electric heaters for DHW heating 6015**")
or
- External heat generator ("**Enable external heat source for DHW heating 7B0D**")

6005 Min. DHW temperature 1

If the actual temperature falls below the minimum temperature selected, the DHW cylinder is heated to the value selected plus hysteresis to protect it against frost. This is independent of the selected operating program.

The temperature is measured via the temperature sensor fitted in the top of the DHW cylinder.

Setting 1 \pm 0.1 °C

6006 Max. DHW temperature 1

DHW heating ends when the temperature in the DHW cylinder has reached the set value. The DHW cylinder will only be heated up again when the temperature has dropped by at least 5 K.

Setting 1 \pm 0.1 °C



Danger

There is a risk of scalding at DHW temperatures **above 60 °C**.

Limit the temperature in the DHW flow by means of a mixing assembly to 60 °C, for example with a thermostatically controlled mixing assembly (DHW cylinder accessory).

6007 Hysteresis DHW temperature heat pump 1

The set value determines at what deviation from the current set temperature ("**Set DHW temperature 6000**" or "**Set DHW temperature 2 600C**") DHW heating with the heat pump starts.

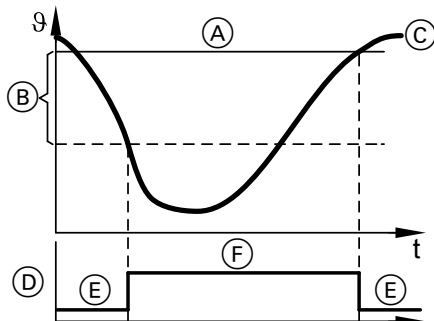

Fig. 55

- (A) Set DHW cylinder temperature
- (B) Heat pump hysteresis ("**Hysteresis DHW temperature heat pump 6007**")
- (C) Actual DHW temperature at the top cylinder temperature sensor
- (D) Demand for DHW heating with heat pump
- (E) OFF
- (F) ON

Note

Set a lower value for "**Hysteresis DHW temperature heat pump 6007**" than for "**Hysteresis DHW temperature booster heater 6008**". Otherwise the proportion of DHW heating provided by the electric heater will increase.

Setting 1 \triangleq 0.1 K

6008 Hysteresis DHW temperature booster heater 1

The set value determines at what deviation from the current set temperature ("**Set DHW temperature 6000**" or "**Set DHW temperature 2 600C**") DHW reheating with the booster heaters starts.

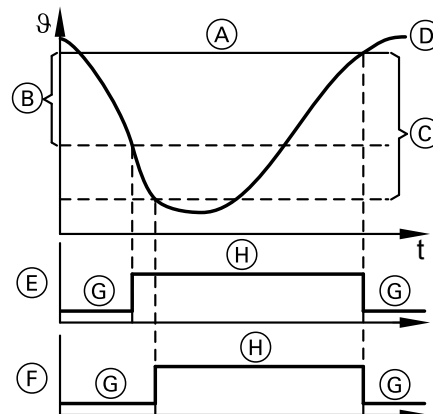

Fig. 56

- (A) Set DHW cylinder temperature
- (B) Heat pump hysteresis ("**Hysteresis DHW temperature heat pump 6007**")
- (C) Booster heater hysteresis ("**Hysteresis DHW temperature booster heater 6008**")
- (D) Actual DHW temperature at the top cylinder temperature sensor
- (E) Demand for DHW heating with heat pump
- (F) Demand for DHW reheating with booster heater
- (G) OFF
- (H) ON

6008 Hysteresis DHW temperature booster heater 1 (cont.)

Note

DHW reheating with electric heaters is only possible if "Enable electric heaters for DHW heating 6015" is set to "1".

Set a higher value for "Hysteresis DHW temperature booster heater 6008" than for "Hysteresis DHW temperature heat pump 6007". Otherwise the proportion of DHW reheating provided by the booster heaters will increase.

Setting 1 \triangleq 0.1 K

6009 Start optimisation for DHW heating

Comfort function for heating the DHW cylinder. The set cylinder temperature has already been reached at the start of a time phase in the time program for DHW heating.

Note

The start time for DHW heating results from "Temperature rise per hour for DHW heating 600D".



"Vitotronic 200" operating instructions

Value	Meaning
"0"	Start optimisation switched off
"1"	Start optimisation switched on

600A Stop optimisation for DHW heating

Comfort function for heating the DHW cylinder. The set cylinder temperature is always reached at the end of a time phase in the DHW heating time program.

Note

The start time for DHW heating results from "Temperature rise per hour for DHW heating 600D".



"Vitotronic 200" operating instructions

Value	Meaning
"0"	Stop optimisation switched off
"1"	Stop optimisation switched on

600C Set DHW temperature 2

Set cylinder temperature for the following functions:

- DHW heating according to time program with operating status "Temp. 2"
- DHW heating outside the time program: "1x DHW heating" or "Manual mode"



"Vitotronic 200" operating instructions

Setting 1 \triangleq 0.1 °C

600D Temperature rise per hour for DHW heating 1

Temperature rise for starting booster heaters

If the temperature rise during DHW heating with the heat pump remains below the set value, the control unit starts the immersion heater, instantaneous heating water heater or external heat generator.

Temperature rise for start and stop optimisation

This parameter specifies the temperature rise for calculating the heat-up time. The relevant start time for DHW heating results from the heat-up duration.

Standard setting value

As a guideline for this setting, it can be assumed that 1 kW of heat pump output raises the temperature of 100 l water by approx. 10 K/h.

Example:

A heat pump with an output of 6 kW therefore raises the temperature of a cylinder volume of 200 l by approx. 30 K/h.

Setting in K/h

600E Temperature sensor at bottom of DHW cylinder 1

If a second temperature sensor is installed at the bottom of the DHW cylinder, DHW cylinder heating in the operating "**Standard**" and "**Temp. 2**" status is stopped via this temperature sensor. This results in the optimisation of DHW cylinder heating.

Value	Meaning
"0"	No cylinder temperature sensor at the bottom.
"1"	Cylinder temperature sensor at the bottom is installed and enabled.

6011 Max. runtime DHW heating in heating mode 1

If during DHW heating there is a simultaneous heat demand from the heating circuits:
The DHW water is heated for the set duration. Central heating then starts, even if the set cylinder temperature has not yet been reached. Following expiry of "**Max. interruption of DHW heating for central heating 6012**" DHW heating is switched on again.
Requirement: Priority for DHW heating has been set (factory setting).

Note

*If there is no heat demand from the heating circuits, the DHW cylinder will be heated independent of the set duration up to reaching the set value ("**Set DHW temperature 6000**" + "**Hysteresis DHW temperature heat pump 6007**").*

 Setting in min

6012 Max. interruption of DHW heating for central heating 1

If during DHW heating there is a simultaneous heat demand from the heating circuits:
The DHW is heated for the duration "**Max. runtime DHW heating in heating mode 6011**". Central heating then starts, even if the set cylinder temperature has not yet been reached. DHW heating is restarted following expiry of the set duration.

Requirement: Priority for DHW heating has been set (factory setting).

 Setting in min

6014 Enable booster heaters for DHW heating 1

An immersion heater integrated into the DHW cylinder can be enabled for DHW reheating. If the set cylinder temperature is not achieved with the heat pump, the heat pump control unit activates the immersion heater.

Note

*Observe setting for "**Hysteresis DHW temperature booster heater 6008**".*

Value	Meaning
"0"	Immersion heater is not enabled for DHW reheating.
"1"	Immersion heater is enabled for DHW reheating. Note <i>If an instantaneous heating water heater is additionally installed in the secondary circuit flow, this is only switched on for protecting the DHW cylinder from frost.</i>

6015 Enable electric heaters for DHW heating

If the set DHW temperature cannot be achieved with the heat pump, the following booster heaters can be activated:

- Instantaneous heating water heater ("**Enable instantaneous heating water heater 7900**") and/or
- Immersion heater ("**Enable booster heaters for DHW heating 6014**")

Note

Observe setting for "**Hysteresis DHW temperature booster heater 6008**".

Value	Meaning
"0"	Instantaneous heating water heater and immersion heater are not enabled for DHW reheating. If these booster heaters are installed, they are only switched on for DHW cylinder frost protection.
"1"	Instantaneous heating water heater and/or immersion heater is enabled for DHW reheating.

6016 Priority DHW heating with combi cylinder 1

Only when using heating water buffer cylinders with integral DHW heating. To reduce the heat-up time, heating up of the heating circuits can be interrupted during DHW heating. For this, the heating circuit pumps of all heating circuits are switched off.

Value	Meaning
"0"	Simultaneous central heating and DHW heating is possible.
"1"	No central heating during DHW heating; all heating circuit pumps are switched off during this time. Note <i>If the outside temperature falls below the frost protection limit, only the heating circuit mixers are closed. The heating circuit pumps remain operational.</i>

6017 Start attempts for DHW after high pressure shutdown 1

High set DHW temperatures can lead to the compressor shutting down due to control high pressure. If there is an existing heat demand, the heat pump control unit tries to restart DHW heating. This parameter determines the number of start attempts. If all attempts result in a high pressure fault, DHW heating is terminated and central heating is switched on.

Enable DHW heating after high pressure fault:

- After expiry of a blocking time.
- or
- Within the blocking time, if the operating status for DHW heating changes from a lower to a higher temperature level, e.g. from "**Top**" to "**Standard**".



"Vitotronic 200" operating instructions

601E Shutdown hysteresis inst. heating water heater 1

This hysteresis serves to specify the max. flow temperature of the instantaneous heating water heater for DHW heating, relative to the max. flow temperature for heat pump operation. The instantaneous heating water heater switches off earlier than the heat pump during DHW heating, as the hysteresis is deducted from the max. flow temperature for heat pump operation.

Note

At setting "0", the heat pump control unit switches the instantaneous heating water heater off at a flow temperature of 65 °C. The heat pump already switches off at 60 °C.

Setting 1 \pm 0.1 K

601F Cylinder primary pump enable 1

Enables the circulation pump on the DHW side for DHW heating in the cylinder loading system (cylinder loading pump); connection to contact 224.6 on the expansion PCB

Note

If the cylinder loading pump is connected to contact 211.4, it does not need to be enabled with this parameter.

Value	Meaning
"0"	No cylinder loading pump installed.
"1"	Cylinder loading pump is activated.

6020 Operating mode cylinder primary pump 1

Switching the cylinder loading pump and type of speed control.

Note

If no cylinder loading pump is available, this parameter enables the operating mode of the secondary pump to be set for DHW heating.

Requirement: "Operating mode secondary pump 7340" is set to "4".

Value	Meaning
"3"	Variable speed operation: Switching by PWM signal. Speed is adjusted via output control (PID controller), so that the set cylinder temperature is reached quickly.
"4"	Do not adjust.

Value	Meaning
"0"	No switching via PWM signal, e.g. with standard circulation pump (multi stage)
"1"	Standard mode: ON/OFF; switching by PWM signal
"2"	Operation at a fixed specified speed; switching by PWM signal

6040 Enable elec. heating/ext. HS for reheating only 1

Applies to instantaneous heating water heaters, immersion heaters and external heat generators.

Value	Meaning
"0"	For DHW reheating, booster heaters enabled for this can be switched on in parallel to the heat pump.
"1"	The compressor stops when the heat pump control unit issues a demand for DHW reheating to one of the enabled booster heaters.

6060 Blocking time DHW heating 1

Once the DHW has been heated to the currently applicable set temperature, the DHW cylinder will not be heated for the specified period. This applies even if the cylinder temperature falls below the switch-on point during this period.

Note

- *If too long a blocking time is set and DHW consumption is high, the cylinder temperature may fall too far.*
- *If "Max. interruption DHW heating 6061" is set to a shorter period than "Blocking time DHW heating 6060", the set blocking time will have no effect. Provided that the stop temperature for the DHW cylinder is undershot, DHW heating will start once the "Max. interruption DHW heating 6061" has expired. This applies even if the start temperature for DHW heating has **not** been undershot.*

6060 Blocking time DHW heating (cont.)

Setting in min

6061 Max. interruption DHW heating

Once the DHW has been heated to the currently applicable set temperature, the DHW cylinder will always be heated following the specified period. This applies even if the cylinder temperature does **not** fall below the switch-on point during this period.

Setting in min

Calling up the parameter group

1. **Service menu:**
Press **OK** +  simultaneously and hold for approx. 4 s.
2. **"Coding level 1"**
3. **"Solar"**
4. Select parameter.

7A00 Type solar control unit 1

Value	Meaning
"0"	No solar control unit installed
"1"	Never adjust
"2"	Never adjust
"3"	Solar control module, type SM1 Set parameter "C0xx".
"4"	Never adjust

C0xx Parameter solar control module, type SM1 1

These parameters are only displayed if the solar control module, type SM1, is connected to the heat pump and is enabled ("Type solar control unit 7A00" is set to "3").



Installation and service instructions "Solar control module, type SM1"

Calling up the parameter group

1. **Service menu:**
Press **OK** + **≡**: simultaneously and hold for approx. 4 s.
2. **"Coding level 1"**
3. **"Electric heater"**
4. Select parameter.

7900 Enable instantaneous heating water heater 1

If an instantaneous heating water heater is installed in the secondary circuit flow, it must be enabled.

Value	Meaning
"0"	<p>Instantaneous heating water heater is disabled.</p> <p>! Please note The instantaneous heating water heater will not start up, even to protect the system from frost. To allow the instantaneous heating water heater to start up for frost protection, select setting "1".</p>
"1"	<p>Instantaneous heating water heater is enabled.</p> <p>! Please note If the secondary circuit is not sufficiently filled with water, the instantaneous heating water heater will overheat. This will damage the instantaneous heating water heater and the high limit safety cut-out. Fill and vent the system fully before enabling the instantaneous heating water heater.</p> <p>Note <i>When setting "1" has been selected with OK, some heat pumps will display the prompt "Secondary circuit filled?". The instantaneous heating water heater is only enabled if this prompt is confirmed with "Yes". Otherwise the setting is set to "2" and the instantaneous heating water heater is not enabled.</i></p>

Value	Meaning
"2"	Never adjust. Instantaneous heating water heater is not enabled . Is automatically set if the prompt "Secondary circuit filled?" was answered with "No" .
"3"	Never adjust. Instantaneous heating water heater is enabled . Is automatically set if the prompt "Secondary circuit filled?" was answered with "Yes" .
"4"	Never adjust.

The instantaneous heating water heater can be used for DHW heating and/or for central heating. This requires the following additional enable commands:

- DHW heating: **"Enable electric heaters for DHW heating 6015"**
- Central heating: **"Enable instant. heating water heater for central heating 7902"**

7901 Enable electric heaters for DHW heating 1

Applies only to the lag heat pump in a heat pump cascade.
The instantaneous heating water heater of the lag heat pump can be started if the set cylinder temperature cannot be achieved with the heat pumps in a heat pump cascade.

Requirements: **"Enable instantaneous heating water heater 7900"** is set to **"1"** on the lag heat pump.

7901 Enable electric heaters for DHW heating 1 (cont.)

Value	Meaning
"0"	Instantaneous heating water heater of the lag heat pump is not enabled for DHW reheating. The instantaneous heating water heater is only switched on for the purpose of DHW cylinder frost protection.
"1"	Instantaneous heating water heater is enabled for DHW reheating.

7902 Enable instant. heating water heater for central heating

If the set flow temperature cannot be achieved with the heat pump, an instantaneous heating water heater installed in the secondary circuit flow can be started for central heating.

Note

The instantaneous heating water heater must be enabled separately with parameter "Enable instantaneous heating water heater 7900".

Value	Meaning
"0"	Instantaneous heating water heater is not enabled for central heating.
"1"	Instantaneous heating water heater is enabled for central heating.

7905 Start delay instantaneous heating water heater 1

Only applies to central heating.

Within the set period the instantaneous heating water heater will **not** start under the following conditions:

- After a change of operating status
- After a change from DHW heating to central heating

During this period, the heat pump control unit does **not** calculate the output integral (integral from duration and extent of deviation of set temperature to actual temperature) that is crucial for the start-up.

Note

Only if there is a very high heat demand will the control unit switch on the instantaneous heating water heater within the set start delay, for example to provide frost protection.

Setting in min

7907 Max. output instantaneous heating water heater 1

Value	Meaning
"1"	Output stage 1, e.g. approx. 3 kW
"2"	Output stage 2, e.g. approx. 6 kW
"3"	Output stages 1 and 2 simultaneously, e.g. approx. 9 kW

790A Output for instant. heating water heater at power-OFF 1

Value	Meaning
"0"	Instantaneous heating water heater remains off during power-OFF, except for frost protection.
"1"	Output stage 1, e.g. approx. 3 kW
"2"	Output stage 2, e.g. approx. 6 kW
"3"	Output stages 1 and 2 simultaneously, e.g. approx. 9 kW

790B Dual mode temp instant. heating water heater 1

Temperature limit for central heating with the instantaneous heating water heater.

If the adjusted outside temperature (long-term average) falls below the dual mode temperature, the heat pump control unit enables operation of the instantaneous heating water heater.

Requirements: The heat pump and/or other heat sources cannot meet the current heat demand on their own.

Above the dual mode temperature, the heat pump control unit only starts the instantaneous heating water heater under the following conditions:

- DHW reheating using instantaneous heating water heater is necessary ("**Enable electric heaters for DHW heating 6015**").
- Heat pump is faulty.

Setting 1 \pm 0.1 °C

Calling up the parameter group

1. **Service menu:**
Press **OK** +  simultaneously and hold for approx. 4 s.
2. **"Coding level 1"**
3. **"Internal hydraulics"**
4. Select parameter.

7300 Heat pump for drying a building

Enabling the heat pump for screed drying.

Due to the high energy demand during screed drying, the heat pump is frequently used in conjunction with an instantaneous heating water heater. This leads to high power consumption.

For this reason, ensure screed drying is covered by the heat pump as much as possible. Possibly leave booster heaters, such as an instantaneous heating water heater, disabled at this stage.

:

- If the heat pump is not ready for use (e.g. primary circuit is not yet completed), set this function to **"0"** (delivered condition).
- Observe probe loading if the heat pump is used for screed drying.

Note

*If a ventilation unit is connected to the heat pump control unit, **"Intensive operation"** is started automatically.*

Value	Meaning
"0"	Heat pump is not used for screed drying.
"1"	Heat pump is used for screed drying.

7303 Time program for screed drying

Temperature/time profile for screed drying (CH: Drying the sub-floor).

! Please note

- High flow temperatures in the underfloor heating circuit lead to the screed being overheated and to building damage.

Install a temperature limiter in the flow of the underfloor heating circuit to limit the maximum temperature.

- **"Time program for screed drying 7303"** affects all heating circuits in parallel.
- **"Heat pump for drying a building 7300"** must be set to **"1"** in order for the heat pump to be switched on for screed drying.
- After a temperature/time profile has been selected, screed drying immediately starts with the set flow temperature for day 1. **"Screed drying"** is displayed in the standard menu. On the following day, the set flow temperature for day 1 is set again.
- Parameter **"Screed program start day 7378"** can be used to set the position of the **start day** within the temperature/time profile.
- Parameter **"Screed program end day 7379"** can be used to set the position of the **last day** of the screed drying program within the temperature/time profile.
- The screed drying program lasts a maximum of 31 days, plus the remaining hours of the start day. The remaining number of days for screed drying can also be checked (**"Screed drying days"**). A maximum of 32 days are displayed for screed drying.  **"Vitotronic 200"** operating instructions
- The selected temperature/time profile continues following a power failure or after the heat pump control unit has been switched off and on again.
- If the temperature/time profile has been completed or if it has been cancelled via temperature/time profile **"0"**, the heat pump continues with the operating program previously set.
- Temperature/time profiles 7 to 12 regulate to the maximum flow temperature.
- The set flow temperature of the heating circuit is limited to **"Max. flow temperature heating circuit 200E"**, even if the temperature/time profile gives a higher value.
- Power consumption increases if the instantaneous heating water heater is started to provide screed drying.

7303 Time program for screed drying 1 (cont.)

Note

Observe the specifications of EN 1264-4. The report to be provided by the heating contractor must contain the following heat-up details:

- Heat-up data with the relevant flow temperatures
- Max. flow temperature achieved
- Operating state and outside temperature at handover

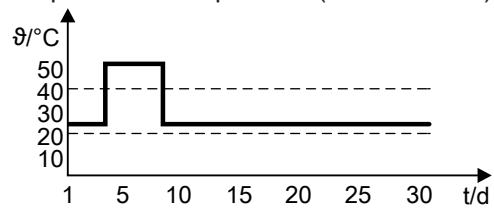
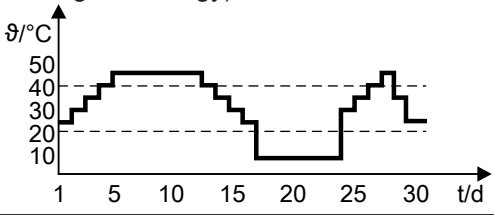
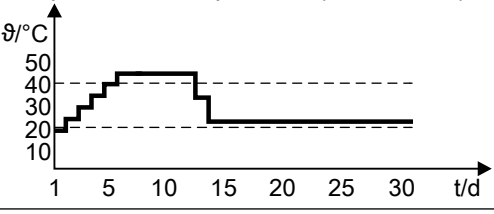
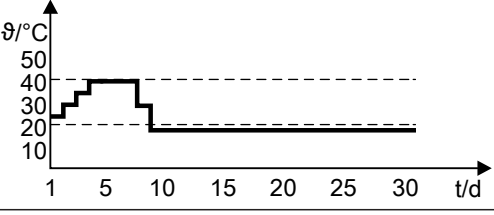
Value	Temperature/time profile ϑ/°C Set flow temperature in °C t/d Time in days
"0"	No temperature/time profile The current temperature/time profile is terminated. Heating or cooling mode continues.
"1"	Temperature/time profile 1 (to EN 1264-4) 
"2"	Temperature/time profile 2 (to ZV parquet and flooring technology) 
"3"	Temperature/time profile 3 (to ÖNORM) 
"4"	Temperature/time profile 4 

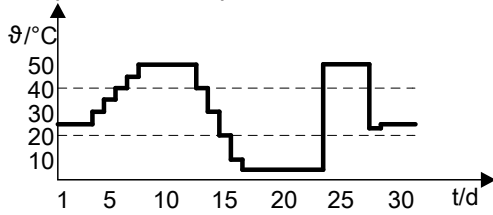
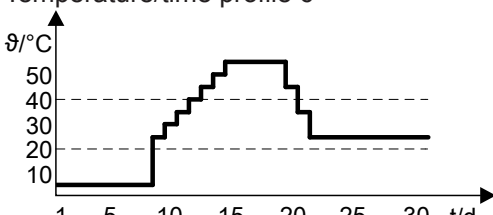
Value	Temperature/time profile ϑ/°C Set flow temperature in °C t/d Time in days
"5"	Temperature/time profile 5 
"6"	Temperature/time profile 6 
"7"	Fixed value temperature program Duration: 5 days
"8"	Fixed value temperature program Duration: 10 days
"9"	Fixed value temperature program Duration: 15 days
"10"	Fixed value temperature program Duration: 20 days
"11"	Fixed value temperature program Duration: 25 days
"12"	Fixed value temperature program Duration: 30 days

730C Flow temperature for external demand 1

Set flow temperature for the secondary circuit in the case of external demand to the heat pump, irrespective of the room temperature or actual outside temperature.

Setting 1 \triangleq 0.1 °C

730D Enable 3-way diverter valve heating/DHW 1

If a pump **and** a 3-way diverter valve are used in the secondary circuit to switch between DHW heating and central heating, set parameter "**Enable 3-way diverter valve heating/DHW 730D**" to "1".

When using 2 pumps (secondary pump and circulation pump for cylinder heating), set this parameter to "0".

Value	Meaning
"0"	<ul style="list-style-type: none"> ▪ No 3-way diverter valve installed. ▪ DHW heating is provided via different hydraulic circuits from central heating using a circulation pump for cylinder heating (on the heating water side). ▪ Secondary pump switched off for DHW heating.
"1"	<ul style="list-style-type: none"> ▪ 3-way diverter valve installed. ▪ Secondary pump runs for DHW heating.

730E Start threshold 1**Start threshold for instantaneous heating water heater and lag heat pump**

To prevent the additional heat source starting immediately if the set temperature is not reached for a short time, the heat pump control unit uses the output integral as start criterion. This integral is formed from the duration and extent of the deviation of the actual flow temperature from the set flow temperature. The output integral is the grey area between the actual flow temperature curve and the set temperature line. Therefore the unit of the output integral is K·min.

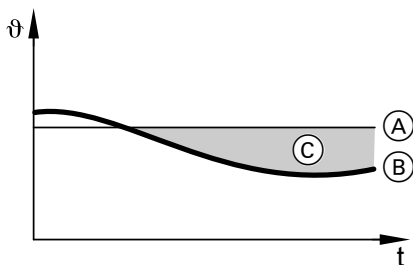

Fig. 57

- (A) Set flow temperature
- (B) Actual flow temperature
- (C) Output integral

Note

Subject to economic and ecological factors, the load manager inside the control unit decides whether to start the instantaneous heating water heater or a lag heat pump.

Level or output matching, modulating heat pumps

In modulating heat pumps (e.g. Vitocal 300-A), when a large difference arises between the actual and set flow temperature in the secondary circuit, the compressor will be regulated to an output of 100 %. The compressor output will not be reduced until this difference decreases.

The set value indicates the degree of reduction. A higher value results in a more pronounced reduction.

Start threshold for active cooling in weather-compensated cooling mode

For active cooling, the set flow temperature must be exceeded in weather-compensated cooling mode. At the same time the integral from actual flow temperature to set flow temperature must exceed the set value. The compressor output required for this is also calculated from this integral.

Setting in K·min

730F Compressor performance at min. outside temperature 1

On heat pumps using compressors with output-dependent control: Default compressor output. In the starting phase, the compressor is regulated to a constant output, in order to improve the control characteristics of the output controller.

This output can be specified separately for minimum and maximum outside temperature. Output values for temperatures between these are calculated using linear interpolation.

730F Compressor performance at min. outside... (cont.)

Note

Set **"Compressor performance at min. outside temperature 730F"** higher than **"Compressor performance at max. outside temperature 7310"**.

Setting in %

7310 Compressor performance at max. outside temperature 1

On heat pumps using compressors with output-dependent control: Default compressor output. In the starting phase, the compressor is regulated to a constant output, in order to improve the control characteristics of the output controller.

This output can be specified separately for minimum and maximum outside temperature. Output values for temperatures between these are calculated using linear interpolation.

Note

Set **"Compressor performance at min. outside temperature 730F"** higher than **"Compressor performance at max. outside temperature 7310"**.

Setting in %

7319 Cycle rate heating circuit pumps 1

In cyclical mode, the following circulation pumps start and stop cyclically. This reduces the energy consumption compared to constant operation.

- All heating circuit pumps in heating systems with buffer cylinder
- Secondary pump in heating systems without buffer cylinder

Cycling is only active if the outside temperature is above $-10\text{ }^{\circ}\text{C}$.

The set value determines the number of cycles at $10\text{ }^{\circ}\text{C}$ over a 24 h period. As the outside temperature falls, the heat pump control unit increases the cycling rate subject to the linear outside temperature. Below $-10\text{ }^{\circ}\text{C}$ the circulation pump is constantly running.

Note

At setting **"0"** cyclical mode is switched off.

Setting in %

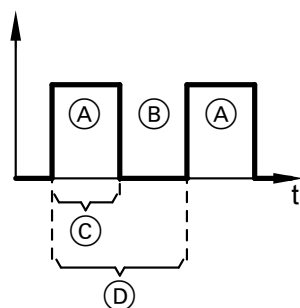

Fig. 58

- (A) Circulation pump ON
- (B) Circulation pump OFF
- (C) ON duration for 1 cycle
- (D) Cycle time

7340 Operating mode secondary pump 1

Switching the secondary pump and type of speed control

7340 Operating mode secondary pump (cont.)

Value	Meaning	
	Central heating	DHW heating
"0"	No switching via PWM signal, e.g. with standard circulation pump (multi stage)	
"1"	Switching via PWM signal: Standard mode: 100 %/0 %	Switching via PWM signal: Default speed 100 %
"2"	Switching via PWM signal: Operation with fixed speed	Switching via PWM signal: Default speed 100 %
"3"	Switching via PWM signal: Speed is adjusted via output control (PID controller), so that a constant temperature spread results in the secondary circuit.	Switching via PWM signal: Default speed 100 %
"4"	Switching via PWM signal: Speed control as for "3"	Switching via PWM signal: <ul style="list-style-type: none"> ▪ Without cylinder loading system: Operating mode set via "Operating mode cylinder primary pump 6020". ▪ With cylinder loading system: Specified speed 100 %
"5"	<input type="checkbox"/> : Regulating to a constant flow rate in the secondary circuit	
"6"	<input type="checkbox"/> : Regulating to a constant flow rate in the secondary circuit: The current set flow rate is dependent on the compressor speed.	

7343 Rated output secondary pump (PWM)

The meaning depends on the setting of **"Operating mode secondary pump 7340"**.

Setting "7340"	Meaning "7343"
"2"	Speed specification for fixed speed operation
"3"	Start value for speed control
"4"	

Note

The secondary pump will be controlled with the set value after the compressor is started.

Setting in %

734A Rated output heating circuit pump HC2

Only in conjunction with the installation kit with mixer (**"Type of assembly kit 7044"** set to "1"): The rated output of the circulation pump contained in the integration kit with mixer for the heating circuit M2/HC2 can be specified. For this, determine the required flow rate. Then set the rated output in accordance with the pump curve.

Note

- Output control is switched off with setting "0". The circulation pump is not switched on.
- In order to prevent flow rate differences, the minimum speed of the secondary pump is automatically adjusted to the value set here for the heating circuit pump M2/HC2.

Setting in %

735A Secondary circuit pump type

Manufacturer of the secondary pump: Required in order to process operating data of the circulation pump in the heat pump control unit.

Value	Meaning
"0"	Wilo
"1"	Grundfos

7365 Starting time high efficiency circulation pump 1

If 1 high efficiency circulation pump each is used for DHW heating and central heating:
 In order to avoid high starting currents, HE circulation pumps will increase their output in stages after starting. Consequently, the flow rate in the start-up phase is very low.

If a changeover between central heating and DHW heating occurs during defrosting, the temperature in the condenser can drop severely as a consequence of the high heat extraction in the case of a low flow rate. To prevent the condenser from freezing up during this process, the flow rate in the secondary circuit can be assured by a run-on of the circulation pump that was active prior to the changeover.

The selected value sets the duration of this run-on time.

Setting in s

7378 Screed program start day 1

After the temperature/time profile has been selected with **"Time program for screed drying 7303"** screed drying starts **immediately**.

Parameter **"Screed program start day 7378"** can be used to set the position of the start day within the temperature/time profile.

The setting value is the start day.

Note

"Heat pump for drying a building 7300" must be set to **"1"** in order for the heat pump to be switched on for screed drying.

Example:

At setting with **"4"**, screed drying **immediately** starts with the set flow temperature of day 4: See temperature/time profile in fig. 59.

If **"Screed program end day 7379"** is set to **"0"**, screed drying will only last for 27 days instead of 31 days.

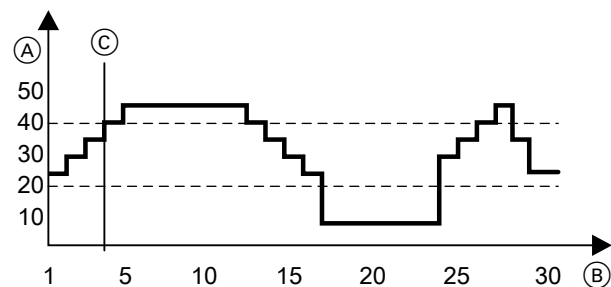

Fig. 59

- (A) Set flow temperature
- (B) Days
- (C) Start day: **"Screed program start day 7378"** = **"4"**

7379 Screed program end day 1

After the temperature/time profile has been selected with **"Time program for screed drying 7303"** screed drying starts **immediately**.

Parameter **"Screed program end day 7379"** can be used to set the position of the last day of the screed drying program within the temperature/time profile.

Note

"Heat pump for drying a building 7300" must be set to **"1"** in order for the heat pump to be switched on for screed drying.

Example:

At setting **"25"**, the screed drying ends on the 25th day of the temperature/time profile: See fig. 60.

If **"Screed program start day 7378"** is set to **"0"**, screed drying will only last for 26 days instead of 31 days.

The setting value is the last day of the screed drying program.

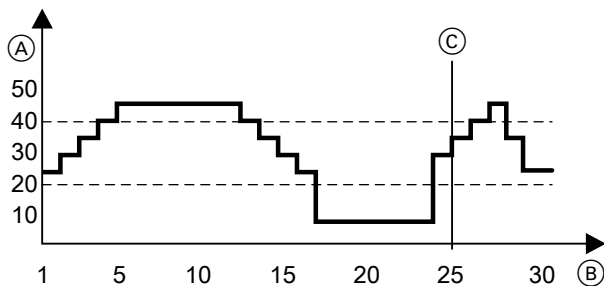

Fig. 60

- (A) Set flow temperature
- (B) Days
- (C) Last day of the screed drying program: **"Screed program end day 7379" = "25"**

Calling up the parameter group

1. **Service menu:**
Press **OK** + simultaneously and hold for approx. 4 s.
2. **"Coding level 1"**
3. **"Primary source"**
4. Select parameter.

7400 Primary source mode 1 /

Type of speed control for the primary pump or fan

Value	Meaning
"0"	No speed control, e.g. with standard circulation pump (multi stage)
"1"	PWM signal from controller and sensor PCB (plug <input type="checkbox"/> 193 A)
"2"	Control via PWM signal from controller and sensor PCB (plug <input type="checkbox"/> 193 A)
"3"	Control via analogue voltage signal from refrigerant circuit controller (0 to 10 V)

7401 Primary source ctrl strategy 1

Control strategy for the fans or primary pump.
Condition: Fan or primary pump is speed-controlled ("Primary source mode 7400" set to "1").

Value	Meaning
"0"	Regulation to constant speed
"1"	Speed control subject to the output curve of the compressor
"2"	Speed control subject to the outside temperature—compressor output curve
"3"	<input type="checkbox"/> / <input checked="" type="checkbox"/> : Speed control subject to the differential between the primary inlet and primary outlet temperature (PID control) <input checked="" type="checkbox"/> <input type="checkbox"/> : Do not adjust.
"4"	<input type="checkbox"/> : Regulating to a constant flow rate in the primary circuit
"5"	<input type="checkbox"/> : Regulating to a constant flow rate in the primary circuit: The current set flow rate is dependent on the compressor speed and the primary circuit flow temperature.

745A Primary circuit pump type 1

Manufacturer of the primary pump: Required in order to process operating data of the circulation pump in the heat pump control unit.

Value	Meaning
"0"	Wilo
"1"	Grundfos

7470 Min. primary circuit inlet temperature in operation

If the primary circuit flow temperature (brine inlet into the heat pump) falls below the set value during heat pump operation, the compressor speed is regulated down depending on the degree of undershooting. If the min. compressor speed is reached in the process, the compressor and the primary pump stop after **"Response delay, probe protection 7471"**.

 Setting 1 \triangleq 0.1 °C

7471 Response delay, probe protection

If the primary circuit flow temperature (brine inlet into the heat pump) falls below the **"Min. primary circuit inlet temperature in operation 7470"** during heat pump operation, the compressor speed is regulated down depending on the degree of undershooting. If the min. compressor speed is reached in the process, the compressor and the primary pump stop after expiry of the set duration.

 Setting in s

Calling up the parameter group

1. **Service menu:**
Press **OK** + **≡**: simultaneously and hold for approx. 4 s.
2. **"Coding level 1"**
3. **"Buffer cylinder"**
4. Select parameter.

7200 Enable buffer cylinder/low loss header 1

Note

Buffer cylinder monitoring is not possible in conjunction with an installation kit with mixer ("**Type of assembly kit 7044**" set to "**1**"). In this case, this parameter has no effect.

Value	Meaning
"0"	Buffer cylinder or low loss header are not installed.
"1"	<p>Heating water buffer cylinder or low loss header is installed:</p> <ul style="list-style-type: none"> ▪ Simultaneous supply of max. 3 connected heating circuits for central heating ▪ Cooling via max. 1 heating/cooling circuit or 1 separate cooling circuit ▪ For cooling, the heating water buffer cylinder is bypassed by a hydraulic bypass circuit. <p>Note Perform settings only in conjunction with system schemes 1 and 2. System schemes 3 to 10 require a buffer cylinder, which is preset. Do not perform any settings for system scheme 11.</p>

Value	Meaning
"2"	<p>Heating water/coolant buffer cylinder is installed:</p> <ul style="list-style-type: none"> ▪ Simultaneous supply of max. 3 connected heating/cooling circuits for central heating or ▪ Simultaneous supply of max. 3 connected heating/cooling circuits for central cooling ▪ No cooling via separate cooling circuit ▪ Manual switching between heating mode and cooling mode of the heating water/coolant buffer cylinder with "Buffer cyl operating mode 721F" <p>Note Adjustable in conjunction with system schemes 1 to 10. Do not perform any settings for system scheme 11.</p>
"3"	Do not adjust.
"4"	Do not adjust.
"5"	Do not adjust.

7202 Temp in operating status fixed value for buffer cyl 1

Applies only to central heating in conjunction with heating water buffer cylinder or heating water/coolant buffer cylinder.
The temperature cannot be set higher than "**Max. temperature buffer cylinder 7204**".

Setting 1 \pm 0.1 °C

7203 Hysteresis temperature heating buffer cylinder 1

The set value determines the deviation from the set buffer temperature at which buffer cylinder heating starts (subject to the operating status).

Note

This function is only available for **system schemes 1 and 2** if "**Enable buffer cylinder/low loss header 7200**" is set to "**1**" or "**2**".

7203 Hysteresis temperature heating buffer... (cont.)

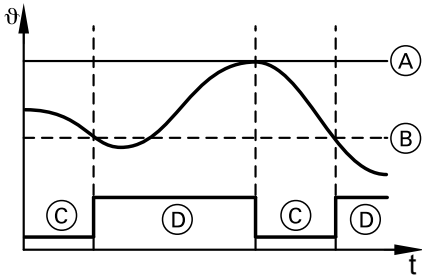

Fig. 61

- (A) Set buffer temperature
- (B) "Hysteresis temperature heating buffer cylinder 7203"
- (C) Heating of buffer cylinder is OFF
- (D) Heating of buffer cylinder is ON

Setting 1 \triangleq 0.1 K

7204 Max. temperature buffer cylinder 1

Heating of the buffer cylinder ends when the buffer temperature reaches the set value.

Setting 1 \triangleq 0.1 °C

Note

- This function is only available for **system schemes 1 and 2** if "**Enable buffer cylinder/low loss header 7200**" is set to "**1**" or "**2**".
- If the value set here is below "**Max. flow temperature heating circuit 200E**", the system may not be able to supply a connected heating circuit with the calculated flow temperature during times of high heat demand.

7205 Stop optimisation heating buffer cylinder 1

Stop optimisation ensures that the temperature inside the buffer cylinder at the end of each time phase in operating status "**Standard**" has reached the currently applicable set value.

Note

With system schemes 1 and 2, stop optimisation is only available if "**Enable buffer cylinder/low loss header 7200**" is set to "**1**" or "**2**".

Value	Meaning
"0"	Stop optimisation disabled
"1"	Stop optimisation enabled

7208 Temp limit op. status fixed value for buffer cylinder 1

If the adjusted outside temperature (long term average) exceeds this temperature limit, the heat pump control unit blocks the operating status "**Fixd value**" (e.g. in summer). The buffer cylinder will then only be heated to the set temperature for operating status "**Standard**".

If this temperature limit is undershot again by 0.5 K (hysteresis), operation of the buffer cylinder is automatically continued in operating status "**Fixd value**".

Note

This function is only available for **system schemes 1 and 2** if "**Enable buffer cylinder/low loss header 7200**" is set to "**1**" or "**2**".

Setting 1 \triangleq 0.1 °C

7209 Stop hysteresis, heating water buffer cylinder 1

If the set buffer temperature is exceeded by the set hysteresis, heating of the buffer cylinder is terminated. Which temperature sensor is used for switching off depends on the active operating status in "**Time program heating water buffer cylinder**".

Setting 1 \pm 0.1 K

720A Operating mode, fixed value only for heat demand 1

The operating status "**Fixd value**" can be blocked for the buffer cylinder if there is no heat demand from any of the connected heating circuits. In such cases, the buffer cylinder is only heated to the set temperature for operating status "**Standard**".

A heat demand from one of the heating circuits is present in the following cases:

- A time phase is active in "**Time program heating**" or "**Time proghtg/cooling**".
- Central heating for frost protection is switched on (operating status "**Standby**").

Value	Meaning
"0"	Operating status " Fixd value " is switched on according to " Time prog buffer cyl ", regardless of whether there is a heat demand from the heating circuits.
"1"	Operating status " Fixd value " is only switched on if a heat demand for one of the connected heating circuits is active.

Note

*This function is only available for **system schemes 1 and 2** if "**Enable buffer cylinder/low loss header 7200**" is set to "1" or "2".*

721F Buffer cyl operating mode ☒ ☒ / ☒

Only for system with heating water/coolant buffer cylinder ("**Enable buffer cylinder/low loss header 7200**" set to "2"):

Value	Meaning
"0"	Central heating is enabled.
"1"	Central cooling is enabled.

7220 Temp in op. status. Fixed value for coolant buff cyl. 1 ☒ ☒ / ☒

Only for system with heating water/coolant buffer cylinder ("**Enable buffer cylinder/low loss header 7200**" set to "2"):

Note

*The temperature cannot be set lower than "**Min. temperature coolant buffer cylinder 722A**".*

Setting 1 \pm 0.1 °C

7223 Stop hysteresis coolant buffer cylinder 1 ☒ ☒ / ☒

Only for system with heating water/coolant buffer cylinder ("**Enable buffer cylinder/low loss header 7200**" set to "2"):

The set value determines the deviation from the set buffer temperature at which cooling of the heating water/coolant buffer cylinder is switched **off** (subject to the operating status).

7223 Stop hysteresis coolant buffer cylinder 1 ... (cont.)

Fig. 62

- (A) **"Start hysteresis coolant buffer cylinder 722B"**
- (B) Set buffer temperature
- (C) **"Stop hysteresis coolant buffer cylinder 7223"**
- (D) Cooling of heating water/coolant buffer cylinder ON
- (E) Cooling of heating water/coolant buffer cylinder OFF

Setting 1 \triangleq 0.1 K**722A Min. temperature coolant buffer cylinder** 1 /

Only for system with heating water/coolant buffer cylinder ("**Enable buffer cylinder/low loss header 7200**" set to "2"):

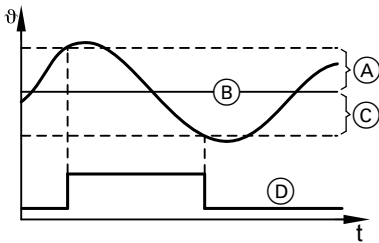
This parameter has both of the following functions:

Stop temperature for cooling of the heating water/coolant buffer cylinder

If the buffer temperature drops below the set value by 1 K, the heating water/coolant buffer cylinder is no longer cooled. The frost protection function is active.

Lower limit for set buffer temperature

The set buffer temperature for room cooling is the lowest set flow temperature of all connected heating/cooling circuits or is specified by the "**Temp in op. status. Fixed value for coolant buff cyl. 7220**".

The set value is the lower limit for the **set buffer temperature**.

Note

*If the value set here is above "**Min. flow temperature cooling 2033**", the system may not be able to supply a connected heating/cooling circuit with the calculated flow temperature during times of high cooling demand.*

Setting 1 \triangleq 0.1 °C**722B Start hysteresis coolant buffer cylinder** 1 /

Only for system with heating water/coolant buffer cylinder ("**Enable buffer cylinder/low loss header 7200**" set to "2"):

The set value determines the deviation from the set buffer temperature at which cooling of the heating water/coolant buffer cylinder is switched **on** (subject to the operating status).

722B Start hysteresis coolant buffer cylinder ... (cont.)

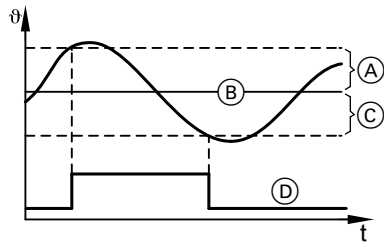



Fig. 63

- Ⓐ **"Start hysteresis coolant buffer cylinder 722B"**
- Ⓑ Set buffer temperature
- Ⓒ **"Stop hysteresis coolant buffer cylinder 7223"**
- Ⓓ Cooling of heating water/coolant buffer cylinder ON
- Ⓔ Cooling of heating water/coolant buffer cylinder OFF

Setting 1 \triangleq 0.1 K

Calling up the parameter group

1. **Service menu:**
Press **OK** +  simultaneously and hold for approx. 4 s.
2. **"Coding level 1"**
3. **"Heating circuit 1"**
or
"Heating circuit 2"
or
"Heating circuit 3"
or
"Separate cooling circuit"
4. Select parameter.

Note

The parameters in parameter groups **"Heating circuit 1"**, **"Heating circuit 2"** and **"Heating circuit 3"** are identical.

The assignment to the heating circuit is determined by the first digit of the parameter code:

2xxx For heating circuit 1 (without mixer A1/HC1)

3xxx For heating circuit 2 (with mixer M2/HC2)

4xxx For heating circuit 3 (with mixer M3/HC3)

The relevant parameters can only be set if a heating circuit is included in the system scheme.

2000 Standard room temperature

Set room temperature for weather-compensated or room temperature-dependent heating or cooling mode (standard room temperature).

Setting 1 \pm 0.1 °C

 Operating instructions

2001 Reduced room temperature

Set room temperature for reduced heating or cooling mode (reduced room temperature).

Note

The maximum value for **"Reduced room temperature 2001"** is 1 K below the current value for **"Standard room temperature 2000"**.

 "Vitotronic 200" operating instructions

Setting 1 \pm 0.1 °C

2003 Remote control 1

One Vitotrol 200-A remote control (with room temperature sensor) can be used for **each** heating/cooling circuit.

 Remote control installation and service instructions

Note

"Room temperature hook-up 200B" must not be set to **"0"** if the room temperature sensor of the remote control is to be used for room temperature hook-up for a heating/cooling circuit.

Value	Meaning
"0"	Remote control is not activated.
"1"	Remote control for the selected heating/cooling circuit is installed and activated. The room temperature sensor is activated.
"2"	<ul style="list-style-type: none"> ▪ External hook-up is active for the selected heating/cooling circuit. ▪ A demand for central heating/cooling is issued via the 230 V~ digital inputs: See "Main PCB". ▪ Operation via remote control is not possible. For further information on external hook-up: See chapter "External hook-up for heating/cooling circuits" in the "Function description".

2003 Remote control 1 (cont.)

Note

In the heat pump setting "**Manual mode**" the remote controls have no function: See "Vitotronic 200" operating instructions.

2005 Room temperature control 1

Room temperature-dependent control of the heating/cooling circuit

Value	Meaning
"0"	Weather-compensated control for central heating is enabled: The heat pump control unit calculates the set flow temperature for the heating circuit from the set room temperature, the outside temperature and the set heating curve.
"1"	Room temperature-dependent control for central heating is enabled: <ul style="list-style-type: none"> ▪ "Heating curve level 2006" and "Heating curve slope 2007" are not adjustable. ▪ Room temperature sensor is connected and enabled ("Remote control 2003" set to "1"), otherwise automatically stays set to "0". ▪ The heat pump control unit calculates the set flow temperature from the current differential between the set and actual room temperature. ▪ System without buffer cylinder or with heating water buffer cylinder: Room temperature-dependent cooling for the heating/cooling circuit can be set with "Room temperature control cooling circuit 7105". ▪ System with heating water/coolant buffer cylinder : Weather-compensated control for central cooling is enabled.

Value	Meaning
"2"	Room temperature-dependent control for central cooling, weather-compensated control for central heating : <ul style="list-style-type: none"> ▪ Only for system with heating water/coolant buffer cylinder ▪ "Cooling curve level 2040" and "Cooling curve slope 2041" are not adjustable. ▪ Room temperature sensor is connected and enabled ("Remote control 2003" set to "1"), otherwise automatically stays set to "0". ▪ The heat pump control unit calculates the set flow temperature from the current differential between the set and actual room temperature.
"3"	Room temperature-dependent control for central heating and for central cooling

Note

If the heating circuit is used for supply air heating (ventilation heating circuit), room temperature-dependent control can not be set ("**Enable reheater bank hydraulic 7D02**").

2006 Heating curve level



Operating instructions

Setting 1 \pm 0.1 K

The values determined from the heating curves for the flow temperature are adopted directly as set values for the heating circuits.

2007 Heating curve slope



Operating instructions

The values determined from the heating curves for the flow temperature are adopted directly as set values for the heating circuits.

200A Influence room temperature hook-up 1

Influence of the room temperature on the set flow temperature of the heating circuit with weather-compensated control. For each Kelvin of differential between the set room temperature and the actual temperature, the set flow temperature is adjusted by the specified value.

Requirements:

- Room temperature sensor installed ("**Remote control 2003**")
- Room temperature hook-up active ("**Room temperature hook-up 200B**")

Example:

- Set room temperature = 20 °C
- Actual room temperature = 18.5 °C
- Deviation between set and actual room temperatures = 1.5 K
- "**Influence room temperature hook-up 200A**" = 2
- Adjustment of the set flow temperature $1.5 \text{ K} \cdot 2 = 3 \text{ K}$

Note

Room temperature hook-up is OFF at a setting of "0".

Set value without unit

200B Room temperature hook-up 1

In conjunction with room temperature sensor ("**Remote control 2003**").

Value	Meaning
"0"	Weather-compensated control without room influence: Set flow temperature is not adjusted.
"1"	Weather-compensated control with room temperature hook-up only for " Reduced " operating status

Value	Meaning
"2"	Weather-compensated control with room temperature hook-up only for " Standard " operating status
"3"	Weather-compensated control with room temperature hook-up for " Reduced " and " Standard " operating status

200E Max. flow temperature heating circuit 1

The set flow temperature, which results from the outside temperature, the heating curve and the set room temperature of the selected heating circuit, is limited by this parameter to a maximum value.

Note

- Since the heat pump control unit only limits the set value with this parameter, a temperature limiter for restricting the maximum temperature (accessories) must be installed in the flow of an **underfloor heating circuit**.
- For central heating via a ventilation heating circuit, this value should not be set above 57 °C for **all** heating circuits.

Setting 1 \triangleq 0.1 °C

2015 Runtime mixer heating circ 1

Time required by the mixer to completely switch between 2 operating states (angle range 90°). This value is a property of the mixer motor: See mixer motor specification. The mixer will "oscillate" if the set time for the mixer used is too short.

Note

This parameter only affects mixers that are switched directly by the heat pump control unit (not for switching via KM-BUS). This parameter is without effect for heating circuits **without** mixer.

Setting in s

2022 Room temperature in party mode

Set room temperature for party mode.

Setting 1 \pm 0.1 °C



Operating instructions

2030 Cooling 1 /

Only for system with heating water/coolant buffer cylinder ("**Enable buffer cylinder/low loss header 7200**" set to "**2**"):

Enable cooling via the heating/cooling circuit.

Value	Meaning
"0"	No cooling
"1"	Do not adjust.
"2"	Cooling with active cooling function

2031 Dew point monitor 1 /

Only for system with heating water/coolant buffer cylinder ("**Enable buffer cylinder/low loss header 7200**" set to "**2**"):

Contact humidistat is connected to connection F11 on the controller and sensor PCB.

Note

A separate contact humidistat is required for each heating/cooling circuit. Connect all contact humidistats to connection F11 in series.

Value	Meaning
"0"	Contact humidistat not connected
"1"	Contact humidistat is connected to connection F11. If a contact humidistat trips, the system behaves as follows: <ul style="list-style-type: none"> ▪ Cooling ends for all heating/cooling circuits connected to the heating water/coolant buffer cylinder which have this value set. ▪ The message "D5 Contact humidistat" appears on the display.
"2"	Contact humidistat is connected to connection F11. If a contact humidistat trips, the system behaves as follows: <ul style="list-style-type: none"> ▪ Cooling ends only for the heating/cooling circuit being monitored by the contact humidistat. ▪ No message is shown on the display.

2033 Min. flow temperature cooling 1 /



Only for system with heating water/coolant buffer cylinder ("**Enable buffer cylinder/low loss header 7200**" set to "**2**"): Lower limit for set flow temperature for central cooling

If the calculation results in a **lower** set flow temperature than the value set here, the **set flow temperature** will be limited to this value.

Setting 1 \pm 0.1 °C

The set flow temperature for cooling mode results from the following:

- Weather-compensated cooling mode:
In line with the set cooling curve and the set room temperature
- Room temperature-dependent cooling mode:
From the differential between the set and the actual room temperature

2034 Influence room temperature hook-up cooling circuit   

Only for system with heating water/coolant buffer cylinder ("**Enable buffer cylinder/low loss header 7200**" set to "**2**"):

The higher the value, the greater the influence of the room temperature on the set flow temperature of the cooling circuit with weather-compensated control.

Conditions:

Room temperature sensor is connected, e.g. via remote control.

Example:

See "**Influence room temperature hook-up 200A**".

Note

Room temperature hook-up is OFF at a setting of "0".

Set value without unit

2040 Cooling curve level  

Only for system with heating water/coolant buffer cylinder ("**Enable buffer cylinder/low loss header 7200**" set to "**2**"):

For weather-compensated central cooling via the heating/cooling circuit, the flow temperature value determined from the cooling curve is adopted directly as the set value.



"Vitotronic 200" operating instructions

Setting 1 \triangleq 0.1 K

2041 Cooling curve slope  

Only for system with heating water/coolant buffer cylinder ("**Enable buffer cylinder/low loss header 7200**" set to "**2**"):

For weather-compensated central cooling via the heating/cooling circuit, the flow temperature value determined from the cooling curve is adopted directly as the set value.



"Vitotronic 200" operating instructions

Setting 1 \triangleq 0.1

Parameter group Cooling

Calling up the parameter group

- Service menu:**
Press **OK** +  simultaneously and hold for approx. 4 s.
- "Coding level 1"**
- "Cooling"**
- Select parameter.

7100 Cooling function 1

Value	Meaning
"0"	No cooling
"1"	Natural cooling with NC-Box without mixer (accessories).
"2"	Natural cooling with NC-Box with mixer (accessories).
"3"	Active cooling

Note

As the compressor is operational for "active cooling", this function must additionally be enabled by the system user: See "Vitotronic 200" operating instructions.

7101 Cooling circuit 1

This parameter determines whether cooling takes place via one of the heating circuits or via a separate cooling circuit.

Value	Meaning
"1"	Cooling via heating circuit A1/HC1
"2"	Cooling via heating circuit M2/HC2
"3"	Cooling via heating circuit M3/HC3
"4"	Cooling via separate cooling circuit SKK

7102 Set room temperature separate cooling circuit



"Vitotronic 200" operating instructions

Preconditions:

- Room temperature sensor (e.g. at F16 on controller and sensor PCB) is connected.
- "Cooling circuit 7101"** is set to **"4"**.

Note

When cooling via a heating/cooling circuit, the set room temperature is determined by **"Standard room temperature 2000"**.

Setting 1 \pm 0.1 °C

7103 Min. flow temperature cooling 1

The set flow temperature for cooling mode results from the following:

- Weather-compensated cooling mode:
In line with the set cooling curve and the set room temperature
- Room temperature-dependent cooling mode:
From the differential between the set and the actual room temperature

Note

The limit of the set flow temperature set here applies to one heating/cooling circuit and for one separate cooling circuit.

Setting 1 \pm 0.1 °C

If the calculation results in a **lower** set flow temperature than the value set here, the **set flow temperature** will be limited to this value.

7104 Influence room temperature hook-up cooling circuit 1

The higher the value, the greater the influence of the room temperature on the set flow temperature of the cooling circuit with weather-compensated control.

Condition:

Room temperature sensor is connected (e.g. via Vitotrol).

Example:

See "Influence room temperature hook-up 200A".

Note

Room temperature hook-up is OFF at a setting of "0".

Set value without unit

7105 Room temperature control cooling circuit 1

For central cooling via a heating/cooling circuit or the separate cooling circuit.

Value	Meaning
"0"	Weather-compensated control for central cooling enabled: The control unit calculates the set flow temperature for the separate cooling circuit from the set room temperature, the outside temperature and the set cooling curve.
"1"	Room temperature-dependent control for central cooling enabled: The control unit calculates the set flow temperature from the current differential between the set and actual room temperature. Slope and level of the cooling curve for the separate cooling circuit cannot be adjusted.

Requirements:

- Central cooling via separate cooling circuit: Room temperature sensor connected to F16 on the controller and sensor PCB.

Note

Alternatively, the room temperature sensor (installed in the Vitotrol) of a different heating/cooling circuit can also be used ("Ranking room temp sensor separate cooling circuit 7106" > "0").

- Central cooling via heating/cooling circuit: Remote control is connected.

Note

Room temperature-dependent cooling ("Room temperature control, cooling circuit 7105" set to "1") and weather-compensated central heating ("Room temperature control 2005" set to "0") can be set simultaneously for one heating/cooling circuit.

7106 Ranking room temp sensor separate cooling circuit 1

This parameter determines which room temperature sensor is used for room temperature-dependent control of the separate cooling circuit.

The room temperature sensors of heating/cooling circuits A1/HC1, M2/HC2 and M3/HC3 are integrated into the remote control.

Value	Meaning
"0"	Room temperature sensor connected directly to the heat pump control unit (connection F16 on controller and sensor PCB)
"1"	Room temperature sensor A1/HC1 is used: Set "Remote control 2003" to "1".

Value	Meaning
"2"	Room temperature sensor M2/HC2 is used: Set "Remote control 3003" to "1".
"3"	Room temperature sensor M3/HC3 is used: Set "Remote control 4003" to "1".
"4"	Never adjust

7107 Hysteresis room temp cooling circuit 1

Hysteresis room temperature for room temperature-dependent cooling mode via heating circuit or separate cooling circuit.

Parameter group Cooling

7107 Hysteresis room temp cooling circuit 1 (cont.)

- Room temperature **exceeds** set room temperature by the set value:
Cooling starts.
- Room temperature **falls below** set room temperature by "**Hysteresis room temp cooling circuit 7107**" times 2:
Cooling is switched off.

Setting 1 \triangleq 0.1 K

Requirement: Room temperature sensor is connected and enabled.

- Heating/cooling circuit:
Remote control room temperature sensor ("**Remote control 2003**")
- Separate cooling circuit:
Room temperature sensor (connection to F16 on controller and sensor PCB): See "**Ranking room temp sensor separate cooling circuit 7106**".

7109 Enable flow temperature sensor cooling circuit 1 /

Flow temperature sensor cooling for cooling via heating circuit **without** mixer A1/HC1 or via a separate cooling circuit: Connection at F14 on the controller and sensor PCB

Note

*For cooling via a heating circuit **with** mixer, the flow temperature sensor used for central heating will also be used for cooling.*

Value	Meaning
"0"	Flow temperature sensor for cooling is not installed. Flow temperature sensor secondary circuit is used.
"1"	Flow temperature sensor cooling is connected and will be used.

7110 Cooling curve level



"Vitotronic 200" operating instructions

Setting 1 \triangleq 0.1 K

The flow temperature value determined from the cooling curve is adopted directly as the set value for the cooling circuit.

7111 Cooling curve slope



"Vitotronic 200" operating instructions

Setting 1 \triangleq 0.1

The flow temperature value determined from the cooling curve is adopted directly as the set value for the cooling circuit.

7116 Remote control cooling circ 1

Never adjust

7117 Dew point monitor 1

Heat pump characteristics if the contact humidistat connected to F11 on the controller and sensor PCB responds.

Value	Meaning
"0"	Compressor does not switch off, no message at the heat pump control unit.
"1"	Compressor stops. The message " D5 Contact humidistat " appears at the heat pump control unit.
"2"	Compressor switches off, no message at the heat pump control unit.

71FE Enable active cooling

This must be enabled **once** in order for the heat pump to start active cooling.



"Vitotronic 200" operating instructions

Calling up the parameter group

1. **Service menu:**
Press **OK** + **≡**: simultaneously and hold for approx. 4 s.
2. **"Coding level 1"**
3. **"Ventilation"**
4. Select parameter.

7D00 Vitovent enable 1

Vitovent				
200-C	200-W	300-C	300-F	300-W
X	X	X	X	X

Enabling of a ventilation unit for operation with the heat pump.

Conditions:

The ventilation unit is connected to the heat pump control unit via Modbus.

Value	Meaning
"0"	No ventilation unit is enabled
"1"	Vitovent 300-F is enabled. The ventilation parameters ("7Dxx") associated with this ventilation unit can be set.
"2"	Vitovent 200-C is enabled. The ventilation parameters ("7Dxx") associated with this ventilation unit can be set.
"3"	Vitovent 200-W, Vitovent 300-C or Vitovent 300-W is enabled. The ventilation parameters ("7Dxx", "C1xx") associated with this ventilation unit can be set.

7D01 Enable preheater bank electric 1

Vitovent				
200-C	200-W	300-C	300-F	300-W
X	—	—	X	—

Conditions:

The electric preheating coil is connected to the controller PCB of the ventilation unit.

Enabling/function of electric preheating coil (accessories) for ventilation unit frost protection.

Value	Vitovent 200-C	Vitovent 300-F
"0"	Preheating coil is not enabled. A defrost function without electric preheating coil can be set with " Strategy, passive frost protection 7D2C ".	Preheating coil is not enabled. Frost protection function without preheating coil is active.
"1"	Defrosting via bypass: If the heat exchanger is iced-up, the bypass is activated. The outdoor air heated by the preheating coil flows past the heat exchanger via the bypass.	Preheating coil is enabled. Frost protection is active.
"2"	Comfort function Frost protection : The electric preheating coil is switched on if the differential between supply air and extract air temperature exceeds 4.5 K.	Never adjust

7D02 Enable reheater bank hydraulic 1

Vitovent				
200-C	200-W	300-C	300-F	300-W
—	—	—	X	—

Enabling the hydraulic reheating coil (accessories) for supply air heating.

Conditions:

The hydraulic reheating coil is installed in the ventilation unit and connected to the heat pump as heating circuit A1/HC1 (ventilation heating circuit).

7D02 Enable reheater bank hydraulic 1 (cont.)

Value	Meaning
"0"	Hydraulic reheating coil is not enabled.
"1"	Hydraulic reheating coil is enabled.

7D04 Enable target temperature control 1

Vitovent				
200-C	200-W	300-C	300-F	300-W
—	—	—	X	—

Supply air heating with the following set supply air temperature: Set flow temperature of the heating circuit minus 5 K.

The set flow temperature is derived from the set room temperature ("**Standard room temperature 2000**" or "**Reduced room temperature 2001**") and the adjusted outside temperature (long-term average) according to the set heating/cooling curve.

Value	Meaning
"0"	Regulation to a constant air flow rate in line with the set ventilation function, operating program and time program
"1"	Specified set air flow rate is regulated subject to the set supply air temperature.

7D05 Enable humidity sensor 1

Vitovent				
200-C	200-W	300-C	300-F	300-W
—	—	—	X	—

Enabling indoor humidity control, for operation with a ventilation unit.

Conditions:

CO₂/humidity sensor (accessories) is connected to the controller PCB of the ventilation unit.

If the "**Standard**" operating status is active in the ventilation time program, the air flow rate is adjusted subject to the humidity. The control limits are "**Flow rate reduced ventilation 7D0A**" and "**Flow rate intensive ventilation 7D0C**".

Value	Meaning
"0"	Humidity control is not enabled.
"1"	Humidity control is enabled.

7D06 Enable CO2 sensor 1

Vitovent				
200-C	200-W	300-C	300-F	300-W
—	—	—	X	—

Enabling indoor CO₂ concentration control, for operation with a ventilation unit.

Conditions:

CO₂/humidity sensor (accessories) is connected to the controller PCB of the ventilation unit.

If the "**Standard**" operating status is active in the ventilation time program, the air flow rate is adjusted subject to the CO₂ concentration. The control limits are "**Flow rate reduced ventilation 7D0A**" and "**Flow rate intensive ventilation 7D0C**".

Value	Meaning
"0"	CO ₂ concentration control is not enabled.
"1"	CO ₂ concentration control is enabled.

7D08 Set room temperature

Vitovent				
200-C	200-W	300-C	300-F	300-W
X	—	—	X	—

Parameter group Ventilation

7D08 Set room temperature (cont.)

Set extract air temperature for ventilation mode.

- At extract air temperatures < **"Set room temperature 7D08"** minus 1 K, the bypass can be activated for **passive heating**. The outdoor air/extract air is **not** routed via the heat exchanger.
- At extract air temperatures > **"Set room temperature 7D08"** plus 1 K, the bypass can be activated for **passive cooling**. The outdoor air/extract air is **not** routed via the heat exchanger.

Note

Further conditions must be met in order for passive heating and passive cooling to be switched on: See **"Min. supply air temperature for bypass 7D0F"** and chapters "Passive heating", "Passive cooling" in the "Function description".

Setting value 1 \pm 0.1 °C

7D0A Flow rate reduced ventilation 1

Vitovent

200-C	200-W	300-C	300-F	300-W
X	—	—	X	—

Set air flow rate for the **"Reduced"** operating status in the ventilation time program (ventilation level )
Setting subject to the building and engineering.

Standard setting values:

- Vitovent 300-F: Centrally between 85 m³/h and **"Flow rate nominal ventilation 7D0B"**
- Vitovent 200-C: Centrally between 70 m³/h and **"Flow rate nominal ventilation 7D0B"**
- or
- Approx. 30 % lower than **"Flow rate nominal ventilation 7D0B"**

Setting in m³/h

7D0B Flow rate nominal ventilation 1

Vitovent

200-C	200-W	300-C	300-F	300-W
X	—	—	X	—

Set air flow rate for the **"Standard"** operating status in the ventilation time program (ventilation level )
Setting subject to the building and engineering.

Set the design flow rate from planning here.

Setting in m³/h

7D0C Flow rate intensive ventilation 1

Vitovent

200-C	200-W	300-C	300-F	300-W
X	—	—	X	—

Set air flow rate for the **"Intensive"** operating status in the ventilation time program (ventilation level )
Setting subject to the building and engineering.

Standard setting values:

- Vitovent 300-F: Centrally between **"Flow rate nominal ventilation 7D0B"** and 280 m³/h
- Vitovent 200-C: Centrally between **"Flow rate nominal ventilation 7D0B"** and 200 m³/h
- or
- Approx. 30 % higher than **"Flow rate nominal ventilation 7D0B"**

Setting in m³/h

7D0F Min. supply air temperature for bypass

Vitovent

200-C	200-W	300-C	300-F	300-W
X	—	—	X	—

To prevent unwanted formation of condensate on the supply air lines, the bypass for passive cooling is only enabled under the following conditions:

7D0F Min. supply air temperature for bypass (cont.)

Vitivent 200-C:

- Outdoor air temperature (heat exchanger air intake) > **"Min. supply air temperature for bypass 7D0F"** plus 0.5 K

Vitivent 300-F:

- Supply air temperature > **"Min. supply air temperature for bypass 7D0F"** minus 1.5 K **and**
- Outdoor air temperature (heat exchanger air intake) > **"Min. supply air temperature for bypass 7D0F"** plus 1.5 K

Note

Further conditions must be met in order for passive cooling to be switched on: See **"Set room temperature 7D08"** and chapter **"Passive cooling"** in the **"Function description"**.

Setting value 1 \pm 0.1 °C

7D18 CO2 value for raising the flow rate 1

Vitivent

200-C	200-W	300-C	300-F	300-W
—	—	—	X	—

The air flow rate is increased if the CO₂ concentration in the room exceeds the set limit. The air flow rate is reduced if this limit is undershot.

The control limits are **"Flow rate reduced ventilation 7D0A"** and **"Flow rate intensive ventilation 7D0C"**.

Requirements:

- CO₂/humidity sensor (accessories) is connected to the controller PCB of the ventilation unit (**"Enable CO2 sensor 7D06"** set to **"1"**).
- "Standard"** operating status is active in the ventilation time program.

Setting in ppm (parts per million)

7D19 Humidity value for raising the flow rate 1

Vitivent

200-C	200-W	300-C	300-F	300-W
—	—	—	X	—

The air flow rate is increased if the relative humidity in the room exceeds the set limit. The air flow rate is reduced if this limit is undershot.

The control limits are **"Flow rate reduced ventilation 7D0A"** and **"Flow rate intensive ventilation 7D0C"**.

Requirements:

- CO₂/humidity sensor (accessories) is connected to the controller PCB of the ventilation unit (**"Enable humidity sensor 7D05"** set to **"1"**).
- "Standard"** operating status is active in the ventilation time program.

Setting in %

7D1A Fan blocking time with frost protection 1

Vitivent

200-C	200-W	300-C	300-F	300-W
—	—	—	X	—

Only in conjunction with electric preheating coil (**"Enable preheater bank electric 7D01"** set to **"1"**):

If the supply air temperature falls below 5 °C, **both** fans are switched off for the set duration. For reactivation, the supply air temperature must exceed 5 °C.

Setting in min

Parameter group Ventilation

7D1B Intensive ventilation duration 1

Vitovent

200-C	200-W	300-C	300-F	300-W
X	—	—	X	—

After expiry of the set duration, if "**Intensive operation**" is set at the heat pump control unit, the control unit automatically restarts the last selected function or the last selected operating program, e.g. "**Ventilation program**".

Note

If "**Economy mode**" was previously active, the control unit starts "**Ventilation program**".

Setting in min

7D1D Actual source room temperature 1

Vitovent

200-C	200-W	300-C	300-F	300-W
—	—	—	X	—

Room temperature sensor for supply air heating via ventilation heating circuit A1/HC1 ("**Enable reheater bank hydraulic 7D02**" set to "**1**").

The room temperature sensor is required in the following cases:

- Weather-compensated control unit with room temperature hook-up ("**Room temperature hook-up 200B**" set to "**1**", "**2**" or "**3**")
- Room temperature-dependent control unit

Value	Meaning
"0"	Ventilation unit extract air temperature sensor is used.
"1"	Room temperature sensor of the Vitotrol is used.

7D21 Heating circuit for blocking bypass damper 1

Vitovent

200-C	200-W	300-C	300-F	300-W
X	X	X	X	X

- With **central heating** via the set heating circuit, the bypass is **not** activated for passive cooling. This prevents the heat supplied via the heating circuit being routed outside via the bypass of the ventilation unit.
- Vitovent 200-C and Vitovent 300-F only: With **room cooling** via the set heating/cooling circuit, the bypass is **not** activated for passive heating. This prevents the heat drawn off via the heating/cooling circuit being reintroduced from outside via the ventilation unit bypass.

Note

Passive heating is not available for the other ventilation units.

Additional conditions where passive heating or cooling is **not** switched on: See chapter "Passive heating" and "Passives cooling" in the "Function description".

Setting in the bit field (see chapter "Setting parameters"): Several bits can be selected.

Note

? opens the setting assistant.

Bit	Meaning
"Bit 1"	Heating circuit A1/HC1
"Bit 2"	Heating circuit M2/HC2
"Bit 3"	Heating circuit M3/HC3

Note

The bypass may be enabled if no Bit is selected.

The setting value results from the combination of selected bits.

7D27 Control voltage matching 1

Vitovent				
200-C	200-W	300-C	300-F	300-W
—	—	—	X	—

Setting 1 \triangleq 0.01 V

To compensate for any pressure differential between the supply air and extract air side, the speed of one fan can be raised compared to the other. To do so the value set here is added permanently to the control voltage of the fan.

7D28 Fan for control voltage matching 1

Vitovent				
200-C	200-W	300-C	300-F	300-W
—	—	—	X	—

Value	Meaning
"0"	Supply air fan
"1"	Exhaust air fan

Fan on which the speed is raised by "**Control voltage matching 7D27**" to compensate for any pressure differential.

Note

To avoid imbalances, the control voltage of the fan that has not been selected is simultaneously limited to 10 V minus "**Control voltage matching 7D27**". This also reduces the maximum air flow rate.

7D2C Strategy, passive frost protection 1

Vitovent				
200-C	200-W	300-C	300-F	300-W
X	—	—	—	—

Value	Meaning
"0"	Shutdown of fans: If the heat exchanger is iced-up, both fans are switched off.
"1"	Defrosting via bypass: If the heat exchanger is iced-up, the bypass opens and the cool outdoor air is routed past the heat exchanger.
"2"	Defrosting by means of disbalance: If the heat exchanger is iced-up, the supply air fan is switched off.

This parameter is used to specify which defrost function is switched on if the heat exchanger ices up.
Conditions:

"**Enable preheater bank electric 7D01**" is set to "0".

7D2E Type of heat exchanger 1

Vitovent				
200-C	200-W	300-C	300-F	300-W
X	—	—	X	—

Type of heat exchanger in the ventilation unit

Parameter group Ventilation

7D2E Type of heat exchanger 1 (cont.)

Value	Meaning
"0"	Countercurrent heat exchanger: Via the countercurrent heat exchanger a large part of the energy from the extract air is transferred to the outdoor air.
"1"	Enthalpy heat exchanger: In addition to heat recovery in accordance with the countercurrent principle, some of the humidity from the extract air is also transferred to the supply air.

7D2F Installation position 1

Vitovent				
200-C	200-W	300-C	300-F	300-W
X	—	—	—	—

Value	Meaning
"0"	Ceiling mounting
"1"	Wall mounting or installation in the roof slope

Ventilation unit installation position

7D3A Function, external 230 V input, ventilation 1

Vitovent				
200-C	200-W	300-C	300-F	300-W
X	—	—	—	—

Value	Meaning
"0"	Bathroom switch cannot be used.
"1"	Bathroom switch can be used.
"2"	Never adjust

The bathroom switch must be activated in order for **"Intensive operation"** to be switched on via an external switch or key (bathroom switch).

7D3B Duration, bathroom vent. 1

Vitovent				
200-C	200-W	300-C	300-F	300-W
X	—	—	—	—

Maximum duration for **"Intensive operation"** if this function was switched on via an external switch or key (bathroom switch).

Setting in min

7D5E Starting block, ventilation periods part 1 1

Vitovent				
200-C	200-W	300-C	300-F	300-W
X	—	—	—	—

Setting in the bit field (see chapter "Setting parameters"): Several bits can be selected.

Note
? opens the setting wizard.

The fans may be switched off to protect the heat exchanger from frost, depending on the temperature conditions and the selected defrost and frost protection function.

If the temperature conditions are no longer met, the fans are restarted at the selected times (00:00 to 15:00 h).

7D5E Starting block, ventilation periods part... (cont.)

Bit	Meaning
"Bit 1"	00:00 o'clock
"Bit 2"	01:00 o'clock
"Bit 3"	02:00 o'clock
...	...
"Bit 16"	15:00 o'clock

Example:

"Bit 3", "Bit 7", "Bit 9" and "Bit 11" are selected:

The fans are restarted at 2:00 h, 6:00 h, 8:00 h and at 10:00 h.

Note

The times from 16:00 to 23:00 h are selected with "**Starting block, ventilation periods part 2 7D5F**".

The setting value results from the combination of selected bits.

7D5F Starting block, ventilation periods part 2 1

Vitovent	200-W	300-C	300-F	300-W
200-C				
X	—	—	—	—

The fans may be switched off to protect the heat exchanger from frost, depending on the temperature conditions and the selected defrost and frost protection function.

If the temperature conditions are no longer met, the fans are restarted at the selected times (16:00 to 23:00 h).

Setting in the bit field (see chapter "Setting parameters"): Several bits can be selected.

Example:

"Bit 1", "Bit 4", "Bit 6" and "Bit 8" are selected:

The fans are restarted at 16:00 h, 19:00 h, 21:00 h and at 23:00 h.

Note

The times from 0:00 to 15:00 h are selected with "**Starting block, ventilation periods part 1 7D5E**".

The setting value results from the combination of selected bits.

Note

? opens the setting wizard.

Bit	Meaning
"Bit 1"	16:00 o'clock
"Bit 2"	17:00 o'clock
"Bit 3"	18:00 o'clock
...	...
"Bit 8"	23:00 o'clock

7D71 Control voltage matching, supply air fan 1

Vitovent	200-W	300-C	300-F	300-W
200-C				
X	—	—	—	—

Setting 1 \pm 0.01 V

To compensate for any pressure differential between the supply air and extract air side, the speed of the **supply air fan** compared to the exhaust air fan can be raised or lowered. To do so the value set here is added permanently to the control voltage of the supply air fan.

7D72 Control voltage matching, exhaust air fan 1**Vitivent**

200-C	200-W	300-C	300-F	300-W
X	—	—	—	—

To compensate for any pressure differential between the supply air and extract air side, the speed of the **exhaust air fan** compared to the supply air fan can be raised or lowered. To do so the value set here is added permanently to the control voltage of the exhaust air fan.

Setting 1 \triangleq 0.01 V**7D75 Sensor matching, outdoor air temperature** 1**Vitivent**

200-C	200-W	300-C	300-F	300-W
X	—	—	—	—

To compensate for systematic measuring errors, a positive or negative adjustment value (offset) can be set for the outdoor air temperature sensor.

Recommendation:

Set "**Standby mode**" for the ventilation unit. After some time, compare the temperature values of all temperature sensors against each other and/or against a reference temperature. Set a corresponding correction value for any deviating temperature sensors.

Setting 1 \triangleq 0.1 K**7D76 Sensor matching, outdoor air temp after preheating coil** 1**Vitivent**

200-C	200-W	300-C	300-F	300-W
X	—	—	—	—

To compensate for systematic measuring errors, a positive or negative adjustment value (offset) can be set for the outdoor air temperature sensor.

Recommendation:

Set "**Standby mode**" for the ventilation unit. After some time, compare the temperature values of all temperature sensors against each other and/or against a reference temperature. Set a corresponding correction value for any deviating temperature sensors.

Setting 1 \triangleq 0.1 K**7D77 Sensor matching, supply air temperature** 1**Vitivent**

200-C	200-W	300-C	300-F	300-W
X	—	—	—	—

To compensate for systematic measuring errors, a positive or negative adjustment value (offset) can be set for the supply air temperature sensor.

Recommendation:

Set "**Standby mode**" for the ventilation unit. After some time, compare the temperature values of all temperature sensors against each other and/or against a reference temperature. Set a corresponding correction value for any deviating temperature sensors.

Setting 1 \triangleq 0.1 K**7D79 Sensor matching, extract air temperature** 1**Vitivent**

200-C	200-W	300-C	300-F	300-W
X	—	—	—	—

To compensate for systematic measuring errors, a positive or negative adjustment value (offset) can be set for the extract air temperature sensor.

7D79 Sensor matching, extract air temperature 1 (cont.)

Recommendation:

Set **"Standby mode"** for the ventilation unit. After some time, compare the temperature values of all temperature sensors against each other and/or against a reference temperature. Set a corresponding correction value for any deviating temperature sensors.

Setting 1 \pm 0.1 K

C101 Preheater coil 1

Vitovent				
200-C	200-W	300-C	300-F	300-W
—	X	X	—	X

Enabling installed electric preheating coil and/or geothermal heat exchanger

Note

? opens the setting wizard.

Bit	Meaning
"Bit 1"	Factory-fitted electric preheating coil: Is always set.
"Bit 2"	Do not adjust.
"Bit 3"	Do not adjust.
"Bit 4"	Do not adjust.

Bit	Meaning
"Bit 5"	Additional electric preheating coil (accessories)
"Bit 6"	Do not adjust.
"Bit 7"	Geothermal heat exchanger in conjunction with a 3-way diverter damper (on site)
"Bit 8" to "Bit 15"	Do not adjust.

The setting value results from the combination of selected bits.

C102 Reheater coil 1

Vitovent				
200-C	200-W	300-C	300-F	300-W
—	X	X	—	X

Never adjust

C105 Humidity sensor 1

Vitovent				
200-C	200-W	300-C	300-F	300-W
—	X	X	—	X

If a humidity sensor is installed in the central extract air duct (header), the air flow rate increases or decreases subject to air humidity.

Value	Meaning
"0"	No central humidity sensor installed.
"1"	The central humidity sensor is installed in the central extract air duct and connected at terminal X4 on the control PCB of the ventilation unit. Humidity control is enabled. Function check: In "Diagnosis" ▶ "Ventilation: Overview" a value greater than 0 % is shown for "Humidity" .

Note

If air humidity control via a the CO₂/humidity sensor is simultaneously active (**"Min. voltage, input 1 C1B1"**, **"Min. voltage, input 2 C1C1"**): Control via the central humidity sensor has priority.

Parameter group Ventilation

C106 CO2 sensor 1

Vitovent

200-C	200-W	300-C	300-F	300-W
—	X	X	—	X

Do not adjust.

C108 set room temperature

Vitovent

200-C	200-W	300-C	300-F	300-W
—	X	X	—	X

Requirement: The bypass is enabled for passive cooling ("**Bypass mode C1A0**" set to "0").

Note

Further conditions must be met in order for passive cooling to be switched on: See chapter "Passive cooling" in the "Function description".

Set bypass temperature for ventilation mode:

At extract air temperatures > "**Set room temperature C108**", the bypass can be activated for **passive cooling**. The outdoor air/extract air is **not** routed via the heat exchanger.

Setting value 1 \pm 0.1 °C

C109 Background ventilation 1

Vitovent

200-C	200-W	300-C	300-F	300-W
—	X	X	—	X

Note for Vitovent 200-W

This setting only applies to the supply air flow rate. The set extract air flow rate is set with "**Background ventilation, second fan duct C189**". Pressure imbalances in the ductwork can be balanced out with different settings for the supply air and extract air flow rates.

Set air flow rate for "**Economy mode**", "**Standard operation**" and "**Holiday program**" (ventilation level .

Setting subject to the building and engineering.

- Vitovent 200-W: Setting in % in accordance with fan curves



Fan curves

Installation and service instructions
"Vitovent 200-W"

- Vitovent 300-C/300-W: Setting in m³/h

Standard setting value:

- Centrally between 0 m³/h and "**Reduced ventilation C10A**"
or
- Approx. 30 % lower than "**Reduced ventilation C10A**"

C10A Reduced ventilation 1

Vitovent

200-C	200-W	300-C	300-F	300-W
—	X	X	—	X

Note for Vitovent 200-W

This setting only applies to the supply air flow rate. The set extract air flow rate is set with "**Reduced ventilation, second fan duct C18A**". Pressure imbalances in the ductwork can be balanced out with different settings for the supply air and extract air flow rates.

Set air flow rate for the "**Reduced**" operating status in the ventilation time program (ventilation level .

Setting subject to the building and engineering.

- Vitovent 200-W: Setting in % in accordance with fan curves



Fan curves

Installation and service instructions
"Vitovent 200-W"

- Vitovent 300-C/300-W: Setting in m³/h

Standard setting values:

- In the middle, between "**Background ventilation C109**" and "**Standard ventilation C10B**"
or
- Approx. 30 % lower than "**Standard ventilation C10B**"

C10B Standard ventilation 1**Vitovent**

200-C	200-W	300-C	300-F	300-W
—	X	X	—	X

Set air flow rate for the **"Standard"** operating status in the ventilation time program (ventilation level ).

Set the design flow rate from planning here.

Note for Vitovent 200-W

*This setting only applies to the supply air flow rate. The set extract air flow rate is set with **"Standard ventilation, second fan duct C18B"**. Pressure imbalances in the ductwork can be balanced out with different settings for the supply air and extract air flow rates.*

- Vitovent 200-W: Setting in % in accordance with fan curves

**Fan curves**

Installation and service instructions
"Vitovent 200-W"

- Vitovent 300-C/300-W: Setting in m³/h

C10C Intensive ventilation 1**Vitovent**

200-C	200-W	300-C	300-F	300-W
—	X	X	—	X

Set air flow rate for the **"Intensive"** operating status in the ventilation time program (ventilation level ).

Setting subject to the building and engineering.

Standard setting values:

- In the middle, between **"Standard ventilation C10B"** and the max. air flow rate

**Max. air flow rate**

Installation and service instructions for the connected ventilation unit

or

- Approx. 30 % higher than **"Standard ventilation C10B"**

Note for Vitovent 200-W

*This setting only applies to the supply air flow rate. The set extract air flow rate is set with **"Intensive ventilation, second fan duct C18C"**. Pressure imbalances in the ductwork can be balanced out with different settings for the supply air and extract air flow rates.*

- Vitovent 200-W: Setting in % in accordance with fan curves

**Fan curves**

Installation and service instructions
"Vitovent 200-W"

- Vitovent 300-C/300-W: Setting in m³/h

C189 Background ventilation, second fan duct 1**Vitovent**

200-C	200-W	300-C	300-F	300-W
—	X	—	—	—

Set air flow rate for **"Economy mode"**, **"Standard operation"** and **"Holiday program"** (ventilation level ).

Setting subject to the building and engineering.

Standard setting value:

- Centrally between 0 m³/h and **"Reduced ventilation, second fan duct C18A"**

or

- Approx. 30 % lower than **"Reduced ventilation, second fan duct C18A"**

Note

*The set supply air flow rate is set with **"Background ventilation C109"**. Pressure imbalances in the ductwork can be balanced out with different settings for the supply air and extract air flow rates.*

Setting in % in accordance with fan curves

**Fan curves**

Installation and service instructions
"Vitovent 200-W"

C18A Reduced ventilation, second fan duct 1

Vitovent

200-C	200-W	300-C	300-F	300-W
—	X	—	—	—

Set extract air flow rate for the **"Reduced"** operating status in the ventilation time program (ventilation level .

Setting subject to the building and engineering.

Standard setting values:

- In the middle between **"Background ventilation, second fan duct C189"** and **"Standard ventilation, second fan duct C18B"**
or
- Approx. 30 % lower than **"Standard ventilation, second fan duct C18B"**

Note

The set supply air flow rate is set with **"Reduced ventilation C10A"**. Pressure imbalances in the ductwork can be balanced out with different settings for the supply air and extract air flow rates.

Setting in % in accordance with fan curves



Fan curves

Installation and service instructions
"Vitovent 200-W"

C18B Standard ventilation, second fan duct 1

Vitovent

200-C	200-W	300-C	300-F	300-W
—	X	—	—	—

Set extract air flow rate for the **"Standard"** operating status in the ventilation time program (ventilation level .

Set the design flow rate from planning here.

Note

The set supply air flow rate is set with **"Standard ventilation C10B"**. Pressure imbalances in the ductwork can be balanced out with different settings for the supply air and extract air flow rates.

Setting in % in accordance with fan curves



Fan curves

Installation and service instructions
"Vitovent 200-W"

C18C Intensive ventilation, second fan duct 1

Vitovent

200-C	200-W	300-C	300-F	300-W
—	X	—	—	—

Set extract air flow rate for the **"Intensive"** operating status in the ventilation time program (ventilation level .

Setting subject to the building and engineering.

Standard setting values:

- In the middle between **"Standard ventilation, second fan duct C18B"** and the max. air flow rate



Max. air flow rate

Installation and service instructions for the connected ventilation unit

or

- Approx. 30 % higher than **"Standard ventilation, second fan duct C18B"**

Note

The set supply air flow rate is set with **"Intensive ventilation C10C"**. Pressure imbalances in the ductwork can be balanced out with different settings for the supply air and extract air flow rates.

Setting in % in accordance with fan curves



Fan curves

Installation and service instructions
"Vitovent 200-W"

C1A0 Bypass mode 1

Vitovent				
200-C	200-W	300-C	300-F	300-W
—	X	X	—	X

How the bypass system works.

Value	Meaning
"0"	Bypass can automatically be activated for passive cooling. Note <i>Further conditions must be met in order for passive cooling to be switched on: See chapter "Passive cooling" in the "Function description".</i>
"1"	The bypass is permanently closed . Heat recovery at the heat exchanger is switched on.
"2"	The bypass is permanently active . Heat recovery at the heat exchanger is switched off.

C1A1 Central heating and heat recovery 1

Vitovent				
200-C	200-W	300-C	300-F	300-W
—	—	X	—	X

Never adjust

C1A2 Imbalance permitted 1

Vitovent				
200-C	200-W	300-C	300-F	300-W
—	X	X	—	X

Balancing of flow rate differences

Due to the conditions in the building, an unwanted differential may occur between the supply air and extract air flow (disbalance), e.g. through different lengths of ductwork for outdoor/supply air and extract/exhaust air. To balance out any flow rate differential, the supply air flow rate can be increased or decreased compared to the extract air flow. This is specified on the ventilation unit using "**Specified imbalance C1A3**": Set "**Imbalance permitted C1A2**" to "1"

Note for Vitovent 200-W

*This setting does **not** apply for Vitovent 200-W: With this ventilation unit, the air flow rates for the supply air and extract air side can be set separately for each ventilation level, e.g. with "**Background ventilation C109**" and "**Background ventilation, second fan duct C189**".*

Air flow rate for frost protection

If the output of both the factory-fitted and the additional electric preheating coils (accessories, installation in outdoor air duct) is not sufficient, the air flow rate is reduced to protect the heat exchanger. Depending on the setting, both air flow rates or only the supply air flow rate are reduced.

Protection against excessively high temperatures

If the outdoor air temperature rises above 60 °C, the ventilation controller either switches off both fans or only the supply air fan.

Parameter group Ventilation

C1A2 Imbalance permitted 1 (cont.)

Value	Meaning
"0"	<ul style="list-style-type: none"> ▪ Supply air and extract air flow rates are reduced for frost protection. ▪ Both fans are switched off to protect against excessively high temperatures. ▪ Only Vitovent 300-C/300-W: No increase or decrease of the supply air stream in comparison to the extract air stream: Supply air and extract air flow rate in the ventilation unit are always the same.
"1"	<ul style="list-style-type: none"> ▪ Only the supply air flow rate is reduced for frost protection. ▪ Only the supply air fan is switched off to protect against excessively high temperatures. ▪ Only Vitovent 300-C/300-W: The supply air flow rate can be increased or decreased compared to the extract air flow rate using "Specified imbalance C1A3".

C1A3 Specified imbalance 1

Vitovent

200-C	200-W	300-C	300-F	300-W
—	—	X	—	X

Due to the conditions in the building, an unwanted flow rate differential (disbalance) may occur between the supply air and extract air side, e.g. through different lengths of pipework for outdoor/supply air and extract/exhaust air.

To even out any imbalance, the supply air flow rate can be increased or decreased compared to the extract air flow. This is specified on the ventilation unit using "**Specified imbalance C1A3**".

Requirement: "**Imbalance permitted C1A2**" is set to "1".

Value	Meaning
"-100"	For positive pressure in the building: Supply air flow rate is decreased by the set value.
"0"	Supply air flow rate and extract air flow rate are equal.
"1" to "100"	For negative pressure in the building: Supply air flow rate is increased by the set value.

Setting in m³/h

C1A4 Set reheater coil temperature 1

Vitovent

200-C	200-W	300-C	300-F	300-W
—	X	X	—	X

Never adjust

C1A6 Humidity sensor sensitivity 1

Vitovent

200-C	200-W	300-C	300-F	300-W
—	X	X	—	X

Sensitivity of the central humidity sensor (accessories):
The sensitivity of the humidity control (response characteristics) can be adjusted if a humidity sensor is installed in the central extract air duct (header) ("**Humidity sensor C105**" is set to "1").
For this a setting range of "-2" (less sensitive) to "+2" (more sensitive) is available.

C1AA Min. temperature, geothermal heat exchanger 1**Vitovent**

200-C	200-W	300-C	300-F	300-W
—	X	X	—	X

Setting 1 \triangleq 0.1 °C

When outside temperatures are low, the outdoor air can be preheated by a geothermal heat exchanger (on site), e.g. to protect the heat exchanger against frost. Below the set temperature, the 3-way diverter damper opens up the path through the geothermal heat exchanger. Above the set temperature the outdoor air flows directly into the ventilation unit.

C1AB Max. temperature, geothermal heat exchanger 1**Vitovent**

200-C	200-W	300-C	300-F	300-W
—	X	X	—	X

Setting 1 \triangleq 0.1 °C

When outside temperatures are warm, the outdoor air can be routed through a geothermal heat exchanger (on site), e.g. for central cooling. Above the set temperature, the 3-way diverter damper opens up the path through the geothermal heat exchanger. Below the set temperature the outdoor air flows directly into the ventilation unit uncooled.

C1B0 Function, input 1 1**Vitovent**

200-C	200-W	300-C	300-F	300-W
—	X	X	—	X

Configuration of input X15.1/X15.2 on the controller PCB of the ventilation unit.

Value	Meaning
"0"	Floating N/O contact
"1"	Analogue signal input 0 – 10 V for connecting the CO ₂ signal in conjunction with a CO ₂ /humidity sensor (accessories)
"2" to "5"	Never adjust

C1B1 Min. voltage, input 1 1**Vitovent**

200-C	200-W	300-C	300-F	300-W
—	X	X	—	X

Switching voltage for the CO₂ signal with a connected CO₂/humidity sensor (accessories).

If the voltage at input X15.1/X15.2 on the controller PCB of the ventilation unit exceeds the set value, the air flow rate is decreased. Below this limit the most recent applicable air flow rate is reactivated.
Recommended setting: **"40"** (\triangleq 4 V)

Setting 1 \triangleq 0.1 V

Parameter group Ventilation

C1C1 Min. voltage, input 2 1

Vitovent

200-C	200-W	300-C	300-F	300-W
—	X	X	—	X

Switching voltage for the humidity signal with a connected CO₂/humidity sensor (accessories).
If the voltage at input X15.3/X15.4 on the controller PCB of the ventilation unit exceeds the set value, the air flow rate is decreased. Below this limit the most recent applicable air flow rate is reactivated.

Recommended setting: **"80"** (± 8 V)

Setting 1 ± 0.1 V

Note

*If air humidity control via the central humidity sensor is simultaneously active ("**Humidity sensor C105**"):
Control via the central humidity sensor has priority.*

C1C7 Flow rate correction 1

Vitovent

200-C	200-W	300-C	300-F	300-W
—	X	X	—	X

Percentage correction factor for the air flow rate. This affects the selected set air flow rates for **all** ventilation levels, e.g. for balancing out system-based pressure drops in the ductwork.

Setting in %

Calling up the parameter group

1. **Service menu:**
Press **OK** + **≡**: simultaneously and hold for approx. 4 s.
2. **"Coding level 1"**
3. **"Photovoltaics"**
4. Select parameter.

7E00 Enable own energy consumption PV 1

Enabling utilisation of power generated on site from the PV system.

Utilisation of power generated on site is active, when **all** of the following criteria apply:

- **"Enable own energy consumption PV 7E00"** is set to **"1"** or **"2"**.
- At least 1 function, e.g. DHW heating, is enabled for utilisation of power generated on site (**"Enable own energy consumption for DHW heating 7E11"** set to **"1"**).
- Over a certain period, the electrical output exported to the grid is greater than the **electrical** output of the heat pump.
- **"Standby mode"** and **"Holiday program"** are **disabled**.

Value	Meaning
"0"	Utilisation of power generated on site is not enabled.
"1"	Utilisation of power generated on site is enabled. The energy meter is connected to the heat pump control unit via Modbus. Consumption data for the utilisation of power generated on site is transferred directly from the energy meter to the heat pump.
"2"	Utilisation of power generated on site is enabled. Consumption data for the utilisation of power generated on site is transferred to the heat pump control unit via a Smart Home system, e.g. Vitocomfort 200.

7E02 Prop. of external current 1

Enabling for drawing power from the grid during utilisation of power generated on site: Applies only to compressors with output-dependent control.

Setting in %

Value	Meaning
"0" to "9"	<p>The compressor must not be operated with power from the grid during utilisation of power generated on site.</p> <p>If the output of the photovoltaic system is insufficient for reaching the adjusted set temperatures, the compressor output will be reduced accordingly.</p> <p>Note <i>In order not to undershoot the minimum speed, the compressor is operated with power from the grid if necessary.</i></p>
"10" to "100"	If the output of the PV system is insufficient for reaching the adjusted set temperatures, the compressor will draw a required proportion of power from the grid.

7E04 Threshold for electrical power 1

In connection with on-site power consumption, the following functions will only start if the electrical PV system output captured by the generation meter (accessories) exceeds the set threshold:

- Advancing DHW heating
- Heating the DHW cylinder to **"Set DHW temperature 2 600C"** once a week
- Raising the temperature inside the buffer cylinder based on the forecast heat demand
- Reduction of set value in the heating water/coolant buffer cylinder by **"Reduce set coolant buffer cylinder temperature PV 7E26"**.
- Central heating:
Raising the set room temperature by **"Raise set room temperature PV 7E23"**.
Central cooling:
Reduction of the set room temperature by **"Raise set room temperature PV 7E23"**.

Setting 1 $\hat{=}$ 0.1 kW

7E10 Enable own energy consumptn for set DHW temperature 2

Once a week, the DHW cylinder is fully heated to **"Set DHW temperature 2 600C"** using electricity from the photovoltaic system. The instantaneous heating water heater can also be started for this (if installed).

Value	Meaning
"0"	Weekly heat-up of the DHW cylinder disabled
"1"	Weekly heat-up of the DHW cylinder enabled

Note

- *This heating of the DHW cylinder only starts if the daily maximum of fed-in electrical power is expected shortly.*
- *If the electrical output of the photovoltaic system is not sufficient during cylinder heating, this process is continued with electricity from the grid.*

7E11 Enable own energy consumption for DHW heating

If DHW heating with on-site power consumption is enabled, the set cylinder temperature increases compared to operation with power from the mains. The increase is set via **"Raise set DHW cylinder temperature PV 7E21"**.

Value	Meaning
"0"	DHW heating with on-site power consumption is disabled.
"1"	DHW heating with on-site power consumption is enabled.

Note

- *If sufficient electricity is available from the PV system, heating can also start outside the selected time phases in the time program.*
- *"Raise set DHW cylinder temperature PV 7E21" will no longer be effective if the electrical output of the PV system is no longer sufficient during cylinder heating. Cylinder heating will continue with power from the mains if a time phase for DHW heating is enabled. Otherwise DHW heating terminates.*

7E12 Enable own energy consumptn for heating water buffer cyl.

If heating of the buffer cylinder with power generated on site is enabled, the set buffer temperature is increased compared to operation with power from the grid, by applying **"Raise set heating water buffer cylinder temp PV 7E22"**.

Note

If the electrical output of the photovoltaic system becomes insufficient during buffer cylinder heating, raising the set buffer temperature ceases to be effective. Charging continues with electricity from the mains until the temperature in the buffer cylinder reaches the currently applicable set value.

Value	Meaning
"0"	Heating the buffer cylinder with power generated on site is disabled.
"1"	Heating the buffer cylinder with power generated on site is enabled.

7E13 Enable own energy consumption for heating

If central heating with on-site power consumption is enabled, the **"Standard room temperature 2000"** or **"Reduced room temperature 2001"** increases compared to operation with power from the mains by **"Raise set room temperature PV 7E23"**.

Note

"Raise set room temperature PV 7E23" will no longer be effective if the electrical output of the PV system is no longer sufficient during central heating.

Value	Meaning
"0"	Central heating with on-site power consumption is disabled.
"1"	Central heating with on-site power consumption is enabled.

7E15 Enable own energy consumption for cooling

The set room temperature (**"Standard room temperature 2000"** or **"Reduced room temperature 2001"**) is reduced, compared to operation with power from the grid by **"Reduce set room temperature PV 7E25"**.

Note

Applicable for cooling via a heating/cooling circuit or the separate cooling circuit.

Value	Meaning
"0"	Central cooling is disabled for on-site power consumption with power generated by the PV system.
"1"	Central cooling is enabled for on-site power consumption with power generated by the PV system.

7E16 Enable own energy consumptn for coolant buffer cylinder

If cooling of the heating water/coolant buffer cylinder with power generated on site is enabled, the set buffer temperature is reduced compared to operation with power from the grid, by applying **"Reduce set coolant buffer cylinder temperature PV 7E26"**.

Note

If the electrical output of the photovoltaic system becomes insufficient whilst the heating water/coolant buffer cylinder is being cooled, "Reduce set coolant buffer cylinder temperature PV 7E26" ceases to be effective. Cooling continues with power from the grid until the temperature in the heating water/coolant buffer cylinder reaches the currently valid set value.

Value	Meaning
"0"	Heating the heating water/coolant buffer cylinder with power generated on site is disabled.
"1"	Heating the heating water/coolant buffer cylinder with power generated on site is disabled.

7E21 Raise set DHW cylinder temperature PV

Raising the set cylinder temperature for DHW heating in the case of on-site power consumption.

Requirements: **"Enable own energy consumption for DHW heating 7E11"** is set to "1".

Setting 1 \triangleq 0.1 K

7E22 Raise set heating water buffer cylinder temp PV

Raising the set buffer temperature for central heating when utilising power generated on site.

Requirements: **"Enable own energy consumptn for heating water buffer cyl. 7E12"** is set to "1".

Setting 1 \triangleq 0.1 K

7E23 Raise set room temperature PV

Raising the set room temperature for central heating in the case of on-site power consumption.

Requirements: **"Enable own energy consumption for heating 7E13"** is set to "1".

Setting 1 \triangleq 0.1 K

7E25 Reduce set room temperature PV

Lowering the set room temperature for central cooling in conjunction with utilisation of power generated on site.

Requirement: **"Enable own energy consumption for cooling 7E15"** set to "1".

Note

Applicable for cooling via a heating/cooling circuit or the separate cooling circuit.

Setting 1 \triangleq 0.1 K

7E26 Reduce set coolant buffer cylinder temperature PV

Reduction of set room temperature for cooling the heating water/coolant buffer cylinder when utilising power generated on site.

Requirement: **"Enable own energy consumptn for coolant buffer cylinder 7E16"** set to "1".

Setting 1 \triangleq 0.1 K

Calling up the parameter group

1. **Service menu:**
Press **OK** + **≡**: simultaneously and hold for approx. 4 s.
2. **"Coding level 1"**
3. **"Smart Grid"**
4. Select parameter.

7E80 Enable Smart Grid 1

The power supply utility can block or specifically issue a demand for the compressor via Smart Grid. This requires 2 floating contacts of the power supply utility to be connected, either to the digital inputs of the heat pump or to the EA1 extension.

Subject to the switching status of the floating contacts, the following functions can be activated by the power supply utility:

- Standard compressor operation
- Compressor is switched OFF (power-OFF).
- Set temperatures are increased for DHW heating, central heating and buffer cylinder heating and lowered for central cooling. The modifications are adjusted via the following parameters:
 - **"Smart Grid set value increase for DHW heating 7E91"**
 - **"Smart Grid set value increase for htg wtr buff 7E92"**
 - **"Smart Grid set value increase for centr htg 7E93"**
 - **"Smart Grid set value decrease for room t cool 7E95"**
- Compressor is switched on. System components are heated to the max. set temperatures or cooled to the min. set temperatures.

Value	Meaning
"0"	Smart Grid is switched off.
"1"	Smart Grid is active. Connection of floating contacts to the digital inputs of the EA1 extension
"2"	Never adjust
"3"	Never adjust
"4"	Smart Grid is active. Connection of the floating contacts to digital inputs 216.1 and 216.4 on the main PCB Note <i>If external hook-up is set for the heating/cooling circuits ("Remote control 2003" set to "2"), Smart Grid via the digital inputs of the main PCB is not possible. In this case, this setting has no effect.</i>

7E82 Smart Grid Enable elec heat 1

If system components are heated to the max. set temperature via Smart Grid, the instantaneous heating water heater can be switched on at the set stage if required.

Value	Meaning
"0"	Instantaneous heating water heater does not start up.
"1"	Stage 1 of the instantaneous heating water heater may be switched on.
"2"	Stage 2 of the instantaneous heating water heater may be switched on.
"3"	Stage 1 and stage 2 of the instantaneous heating water heater may be switched on. The instantaneous heating water heaters of all lag heat pumps are enabled for operation with Smart Grid. The respective enabled stage is set with this parameter at the associated lag heat pump.

Parameter group Smart Grid

7E91 Smart Grid set value increase for DHW heating

If the function for increasing set temperatures is active via Smart Grid, **"Set DHW temperature 6000"** is raised by this value.

Setting 1 \triangleq 0.1 K

7E92 Smart Grid set value increase for htg wtr buff

If the function for increasing set temperatures is active via Smart Grid, the current set temperature for the buffer cylinder is raised by this value. The current set temperature depends on the active operating status of the buffer cylinder in **"Time prog buffer cyl"**.

Setting 1 \triangleq 0.1 K

7E93 Smart Grid set value increase for centr htg

If the function for increasing set temperatures is active via Smart Grid, the current set room temperature is raised by this value. The current set room temperature depends on the active operating status in the **"Time program heating"** or **"Time prog htg/cooling"**.

Requirements: Central heating is switched on.

Setting 1 \triangleq 0.1 K

7E95 Smart Grid set value decrease for room t cool

If the function for increasing set temperatures is active via Smart Grid, the current set room temperature is reduced by this value. The current set room temperature depends on the active operating status in the **"Time prog htg/cooling"**.

Requirements: Central cooling is switched on.

Setting 1 \triangleq 0.1 K

Calling up the parameter group

1. **Service menu:**
Press **OK** + **≡**: simultaneously and hold for approx. 4 s.
2. **"Coding level 1"**
3. **"Time"**
4. Select parameter.

7C00 to 7C06 Automatic changeover summertime - wintertime 1

In the delivered condition, the changeover will always take place in the night from Saturday to Sunday on the last weekend in March and October. This setting can be changed with parameters **"Summertime - month"**, **"Summertime - week"**, **"Summertime - day"**, **"Wintertime - month"**, **"Wintertime - week"**, and **"Wintertime - day"**.

Parameter	Delivered condition	Setting range	
"Automatic changeover summertime - wintertime 7C00"	"1"	"1" "0"	Automatic changeover enabled. Automatic changeover not enabled.
"Start summertime - month 7C01"	"3"	"1" to "12"	January to December
"Start summertime - week 7C02"	"5"	"1" to "5"	First to last week of the month
"Start summertime - day 7C03"	"7"	"1" to "7"	Monday to Sunday
"Start wintertime - month 7C04"	"10"	"1" to "12"	January to December
"Start wintertime - week 7C05"	"5"	"1" to "5"	First to last week of the month
"Start wintertime - day 7C06"	"7"	"1" to "7"	Monday to Sunday

Calling up the parameter group

1. **Service menu:**
Press **OK** +  simultaneously and hold for approx. 4 s.
2. **"Coding level 1"**
3. **"Communication"**
4. Select parameter.

7707 Number of heat pump in cascade 1

Number of the lag heat pump in a heat pump cascade via LON.

Numbers within a LON must be unique.

If **no** runtime compensation is set, this number can be used to determine the start sequence for the lag heat pumps.

With runtime compensation, the number specified here has **no** effect on the start sequence. In this case, it is always the lag heat pump with the lowest runtime that is started first.

Setting is the lag heat pump number.

7710 Enable LON communication module 1

Value	Meaning
"0"	LON communication module is not enabled.
"1"	LON communication module is enabled.

7777 LON subscriber number 1

Number ranges in the LON addresses for the heat pump control unit.

The addresses of LON subscribers consist of 3 different parts, as in a telephone network (country code, area code, subscriber number). The first part is permanently set to the same value for all Viessmann appliances. The other parts consist of the LON system number and LON subscriber number.

Note

Observe the following to prevent communication conflicts:

- Each LON subscriber number must only be assigned **once** within a individual system.
- Do **not** set LON subscriber number **99** for the heat pump control unit. This is the LON subscriber number of the Vitocom communication interface.

Setting is LON subscriber number.

7779 LON fault manager 1

The heat pump control unit, which acts as fault manager, displays all the system fault messages. Furthermore, it monitors all subscribers for failure and generates central fault messages.

Note

Only one control unit within a system may be configured as the fault manager. Exception: The Vitocom communication interface may be an additional fault manager.

Value	Meaning
"0"	Heat pump control unit is not fault manager.
"1"	Heat pump control unit is fault manager.

7798 LON system number 1

Number ranges in the LON addresses.

7798 LON system number 1 (cont.)

The addresses of LON subscribers consist of three different parts, as in a telephone network (country code, area code, subscriber number).
The first part is permanently set to the same value for all Viessmann appliances. The other parts consist of the LON system number and LON subscriber number.

Setting is system number.

779C Interval for data transfer via LON 1

Receive interval for the values and messages transmitted via LON.
If no signal is received for a magnitude or message within this set period, the control unit sets this value or status to an internal preset until the signal is received again.

Setting in min

77FC Source outside temperature 1

The heat pump control unit can receive the outside temperature from different sources.

Value	Meaning
"0"	The heat pump control unit captures the outside temperature via the outside temperature sensor connected to the controller and sensor PCB.
"1"	The heat pump control unit receives the outside temperature from another LON subscriber with the same system number (" LON system number 7798 "). <i>Note</i> Only one subscriber within a system in LON may send the outside temperature.

Value	Meaning
"2"	The heat pump control unit receives the outside temperature from an external device via KM BUS, e.g. wireless base station.
"3"	Do not set.

77FD Send outside temperature 1

To ensure that all LON subscribers use the same outside temperature, the heat pump control unit can transmit this value to other LON subscribers.

Note
Only one subscriber within a system in LON may send the outside temperature.

Value	Meaning
"0"	Outside temperature is not sent.
"1"	The heat pump control unit transmits the outside temperature in LON. All LON subscribers with the same system number can receive this value (" LON system number 7798 ").

77FE Source time 1

The heat pump control unit can receive the time from different sources.

Value	Meaning
"0"	The heat pump control unit uses the time from the internal clock.



Parameter group Communication

77FE Source time 1 (cont.)

Value	Meaning
"1"	The heat pump control unit receives the time from another LON subscriber with the same system number (" LON system number 7798 "). Note <i>Only one subscriber within a system in LON may send the time.</i>

Value	Meaning
"2"	The heat pump control unit receives the time from an external device via KM BUS, e.g. wireless base station.
"3"	The heat pump control unit receives the time via radio clock receiver (accessory, connection to controller and sensor PCB).

77FF Send time 1

The heat pump control unit can transmit this value to other LON subscribers to ensure that all LON subscribers use the same time.

Note
Only one subscriber within a system in LON may send the time.

Value	Meaning
"0"	Time is not sent.
"1"	The heat pump control unit transmits the time in LON. All LON subscribers with the same system number can receive this value (" LON system number 7798 ").

Calling up the parameter group

1. **Service menu:**
Press **OK** + **≡**: simultaneously and hold for approx. 4 s.
2. **"Coding level 1"**
3. **"Control"**
4. Select parameter.

8800 Lock out controls 1

Value	Standard menu	Extended menu
"0"	✓	✓
"1"	✓	^
"2"	^	^

- ✓ Control enabled
- ^ Controls locked

Note

- Remote control and remote maintenance in conjunction with Vitocom are possible irrespective of these settings.
- Enabling the controls via coding level 1 is also possible in the blocked condition (settings "1" and "2").

8801 Level enable, time program quieter operation 1

This parameter is used to specify in which setting level the time program for quieter operation can be set ("**Time prog. noise red.**").

Value	Meaning
"0"	Setting level "System user"
"1"	Setting level "Contractor"
"2"	Do not adjust. " Time prog. noise red. " can no longer be adjusted.
"3"	Do not adjust. " Time prog. noise red. " can no longer be adjusted.

8811 User level for display, energy stmt/SPF 1

This parameter specifies the menu in which the "**Energy statement**" can be displayed.

Value	Meaning
"0"	" Energy statement " is not displayed.
"1"	Display under " Diagnosis " ► " Energy statement " ("Contractor" setting level)
"2"	Display under <ul style="list-style-type: none"> ▪ "Diagnosis" ► "Energy statement" ("Contractor" setting level) and ▪ Extended menu ≡: ► "Information" ► "Energy statement" ("System user" setting level)

Note

Which energy statements are available depends on the appliance type and the system version.

Overview of the PCBs



PCB locations in the heat pump

Heat pump installation and service instructions

Brine/water and air/water heat pumps □ / ⊗

PCB	Vitocal				
	200-A	300-A	300-A	222-G	333-G
	Type AWCI-AC 201.A	AWO-AC 301.B	AWO 302.B	All	All
Main PCB (230 V~ components): See page 280.	●	○	○	●	●
Expansion PCB (230 V~ components): See page 284.	●	○	○	●	●
Cross connect PCB (message and safety connections): See page 289.	—	○	○	—	—
Vitocal 200-A luster terminals (message and safety connections): See page 296.	●	—	—	—	—
Vitocal 222-G/333-G luster terminals (message and safety connections): See page 299.	—	—	—	●	●
Vitocal 100-S/200-A/200-S/300-A controller and sensor PCB: See page 300.	●	○	○	—	—
Vitocal 111-S/222-A/222-S/222-G/333-G controller and sensor PCB: See page 302.	—	—	—	●	●
EEV PCB [2]: See page 304.	●	—	—	—	—
EEV PCB [4]: See page 304.	—	●	—	—	—
EEV PCB [4-6] / [4-7]: See page 308.	—	—	—	●	●
Controller PCB and EEV PCB [6]: See page 310.	—	—	●	—	—

- Integrated into the heat pump
- Integrated into the separate control unit enclosure
- Not installed

Overview of the PCBs (cont.)

Heat pumps with separate indoor and outdoor unit

PCBs in the indoor unit

PCB	Vitocal					
	100-S	111-S	200-A	222-A	200-S	222-S
Main PCB (230 V~ components): See page 280.	X	X	X	X	X	X
Expansion PCB (230 V~ components): See page 284.	X	X	X	X	X	X
Vitocal 100-S/200-A/200-S luster terminals (message and safety connections): See page 292.	X	—	X	—	X	—
Vitocal 111-S/222-A/222-S luster terminals (message and safety connections): See page 294.	—	X	—	X	—	X
Vitocal 100-S/200-A/200-S controller and sensor PCB: See page 300.	X	—	X	—	X	—
Vitocal 111-S/222-A/222-S/222-G/333-G controller and sensor PCB: See page 302.	—	X	—	X	—	X

X Installed

— Not installed

PCBs in the outdoor unit

PCB	Vitocal					
	100-S	111-S	200-A	222-A	200-S	222-S
EEV PCB [4-3] / [4-4]: See page 307.	—	—	X	X	X	X
Main PCB [7] / [7-1]: See page 312.	X	X	—	—	—	—

X Installed

— Not installed

Information regarding the electrical connections



Installation and service instructions of the relevant heat pump

- The total output of all components connected directly to the heat pump control unit (e.g. pumps, valves, signalling equipment, contactors) must not be in excess of 1000 W.
If the total output \leq 1000 W, the individual rating of a component (e.g. pump, valve, message facility, contactor) can be greater than specified. However, the breaking capacity of the corresponding relay must not be exceeded: See following chapter.
- In the delivered condition, terminals may have been pre-allocated (depending on appliance version).
If 2 components are connected to the same terminal, press both wires together in a **single** wire ferrule.

- The KM-BUS wires are interchangeable.
- The Modbus wires are **not** interchangeable.
- The neutral and earth conductors of all components are connected as follows, depending on the heat pump type:
 - Terminals X2.N and X1.⊕ of the cross connect PCB
 - Terminals X2.N and X1.⊕ of the luster terminals

Note

Only the connections to be made are shown in the following PCB diagrams. Pre-allocated connections made at the factory are also explained in the tables.

Main and expansion PCB

Main PCB

For allocation to heat pump type: See "Overview of PCBs".

230 V~ components

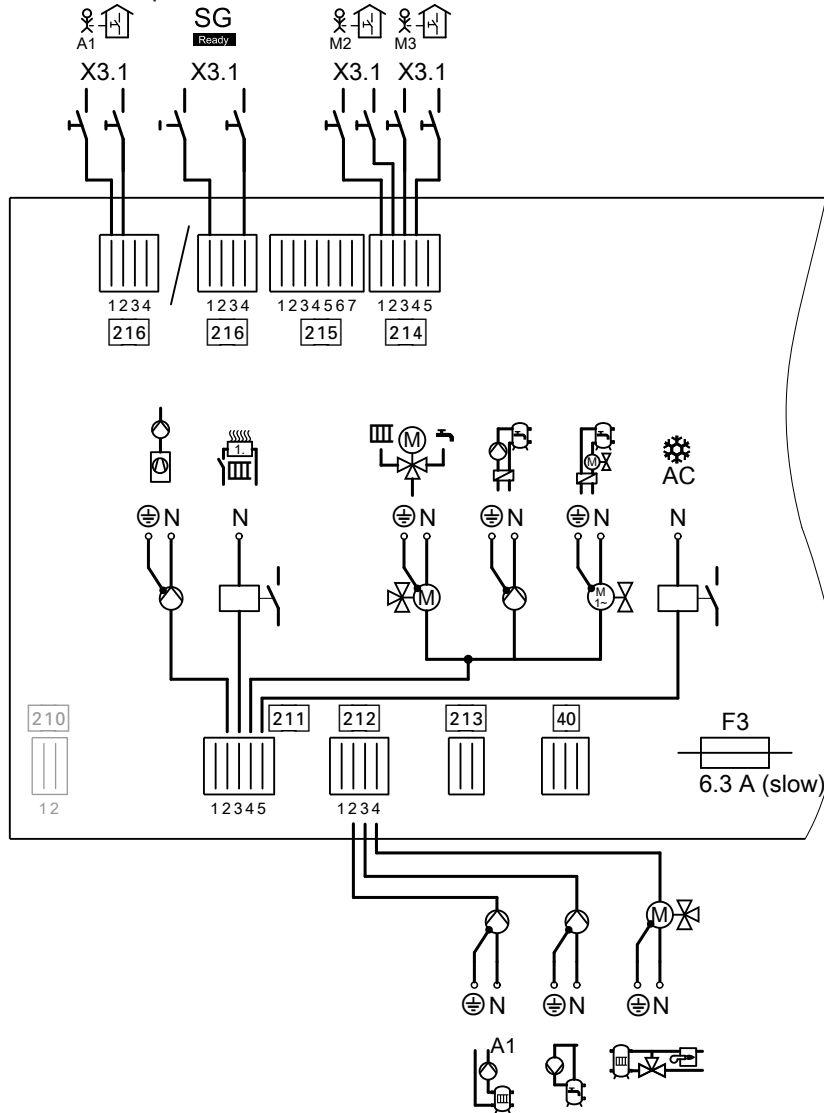

Fig. 64

- F3 Fuse 6.3 A (slow)
- 40 Internal power supply, control unit (factory connection)
- 211/212 230 V~ components (on-site connection)
- 213, 215 Factory connections
- 214 External hook-up, heating/cooling circuits
- 216 External hook-up, heating/cooling circuits or Smart Grid

Notes regarding the connection values















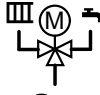

- The specified output is the recommended connected load.
- The specified current indicates the max. switching current of the switching contact. Observe the total current of all connected components of 5 A.

Plug 40



Terminals	Function	Explanation
	Internal power supply of the PCBs	—

Main and expansion PCB (cont.)



Plug 211

Terminals	Function	Explanation
211.2 	 /  Secondary pump Note  <i>The secondary pump is connected directly to the EEV PCB: See chapter "EEV PCB [4-6] / [4-7]"</i>	<ul style="list-style-type: none"> In systems without a buffer cylinder, no other heating circuit pump is required: See terminal 212.2. Connect a temperature limiter to restrict the maximum temperature for underfloor heating circuits (if installed) in series. Connection values <ul style="list-style-type: none"> Output: 140 W Voltage: 230 V~ Max. switching current: 4(2) A
211.3 	Control of instantaneous heating water heater, stage 1	Connection values <ul style="list-style-type: none"> Output: 10 W Voltage: 230 V~ Max. switching current: 4(2) A
211.4    	<ul style="list-style-type: none"> 3-way diverter valve "Central heating/DHW heating"  : <ul style="list-style-type: none"> Circulation pump for cylinder heating  : <ul style="list-style-type: none"> Cylinder loading pump  : <ul style="list-style-type: none"> 2-way shut-off valve 	Connection values <ul style="list-style-type: none"> Output: 130 W Voltage: 230 V~ Max. switching current: 4(2) A Note <i>Depending on the heat pump and system version, not all components may be installed: See "DHW heating connections".</i>
211.5 ⊗ NC ⊗ AC	Control of cooling  Natural cooling function  /  3-way diverter valves for heating water buffer cylinder bypass with the active cooling function	 NC-Box (accessories) or on-site components for NC cooling  /  Connect the 3-way diverter valves in parallel. Connection values <ul style="list-style-type: none"> Output: 10 W Voltage: 230 V~ Max. switching current: 4(2) A





Plug 212

Terminals	Function	Explanation
212.1 ⊗ AC	Control of cooling  Active cooling function	AC-Box or on-site components for AC cooling Connection values <ul style="list-style-type: none"> Output: 10 W Voltage: 230 V~ Max. switching current: 4(2) A
212.2 	Heating circuit pump for heating circuit without mixer A1/HC1	<ul style="list-style-type: none"> This pump is connected in addition to the secondary pump if a buffer cylinder is installed. Connect a temperature limiter to restrict the maximum temperature for underfloor heating circuits (if installed) in series. Connection values <ul style="list-style-type: none"> Output: 100 W Voltage: 230 V~ Max. switching current: 4(2) A

Main and expansion PCB (cont.)





Terminals	Function	Explanation
212.3 	DHW circulation pump	Connection values <ul style="list-style-type: none"> Output: 50 W Voltage: 230 V~ Max. switching current: 4(2) A
212.4 	3-way diverter valve for heating water buffer cylinder bypass or heat pump in the case of dual alternative mode	Connection values <ul style="list-style-type: none"> Output: 130 W Voltage: 230 V~ Max. switching current: 4(2) A

Plug 214

Terminals	Function	Explanation
214.1  M2	Central heating demand, heating circuit M2/HC2	230 V~ digital input: <ul style="list-style-type: none"> 230 V~: Central heating demand for heating circuit M2/HC2 active 0 V: No demand Breaking capacity 230 V, 0.15 A
214.2  M2	Central cooling demand, heating circuit M2/HC2	230 V~ digital input: <ul style="list-style-type: none"> 230 V~: Central cooling demand for heating circuit M2/HC2 active 0 V: No demand Breaking capacity 230 V, 0.15 A
214.3  M3	Central heating demand, heating circuit M3/HC3	230 V~ digital input: <ul style="list-style-type: none"> 230 V~: Central heating demand for heating circuit M3/HC3 active 0 V: No demand Breaking capacity 230 V, 0.15 A
214.4  M3	Central cooling demand, heating circuit M3/HC3	230 V~ digital input: <ul style="list-style-type: none"> 230 V~: Central cooling demand for heating circuit M3/HC3 active 0 V: No demand Breaking capacity 230 V, 0.15 A

Main and expansion PCB (cont.)

Plug 216

Terminals	Function	Explanation
216.1  A1  SG	Central heating demand, heating circuit A1/HC1 or Smart Grid, floating contact 1	230 V~ digital input: <ul style="list-style-type: none"> ▪ 230 V~: Central heating demand for heating circuit A1/HC1 active ▪ 0 V: No demand ▪ Breaking capacity 230 V, 2 mA 230 V~ digital input: <ul style="list-style-type: none"> ▪ 230 V~: Contact active ▪ 0 V: Contact not active ▪ Breaking capacity 230 V, 2 mA Function dependent on terminal 216.4: See "Smart Grid" chapter in the "Function description".
216.2  A1	Central cooling demand, heating circuit A1/HC1	230 V~ digital input: <ul style="list-style-type: none"> ▪ 230 V~: Central cooling demand for heating circuit A1/HC1 active ▪ 0 V: No demand ▪ Breaking capacity 230 V, 0.15 A
216.4  SG	Smart Grid, floating contact 2	230 V~ digital input: <ul style="list-style-type: none"> ▪ 230 V~: Contact active ▪ 0 V: Contact not active ▪ Breaking capacity 230 V, 2 mA Function dependent on terminal 216.1: See "Smart Grid" chapter in the "Function description".

Expansion PCB on main PCB

For allocation to heat pump type: See "Overview of PCBs".

230 V~ components

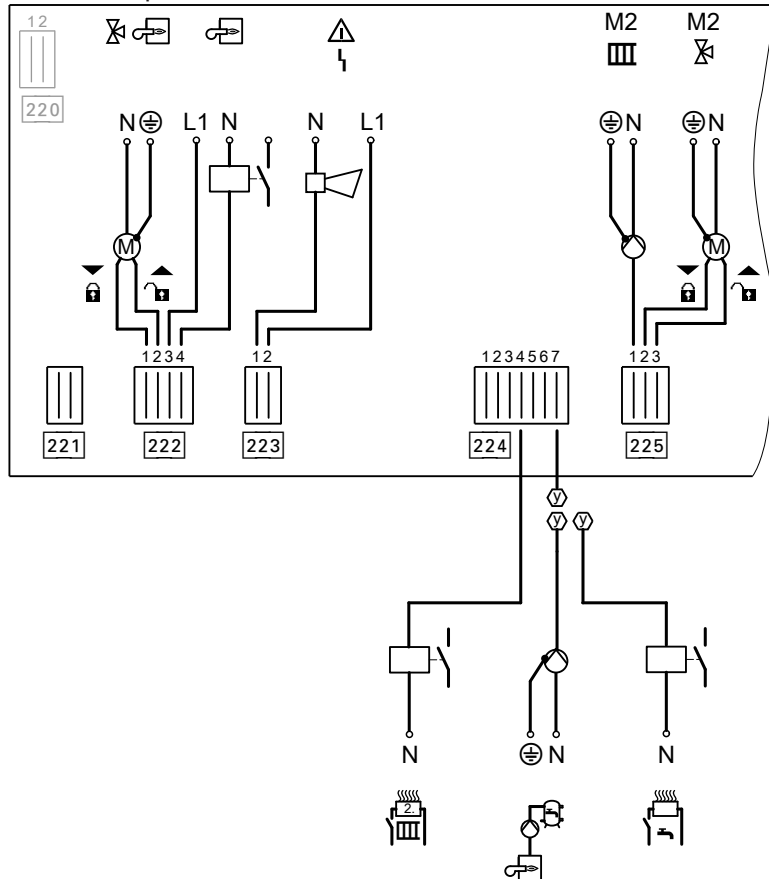

Fig. 65











- 220 No function
- 222 to 225 230 V~ components

Notes regarding the connection values

- The specified output is the recommended connected load.
- The specified current indicates the max. switching current of the switching contact. Observe the total current of all connected components of 5 A.
- The relay contacts for external heat generator and central fault messages are unsuitable for safety LV.

Main and expansion PCB (cont.)





Plug 222

Terminals	Function	Explanation
222.1  ▼ 	 /  Control of mixer motor for external heat generator Signal mixer CLOSE	Connection values <ul style="list-style-type: none"> Output: 10 W Voltage: 230 V~ Max. switching current: 0.2(0.1) A
222.2  ▲ 	 /  Control of mixer motor for external heat generator Signal mixer OPEN	Connection values <ul style="list-style-type: none"> Output: 10 W Voltage: 230 V~ Max. switching current: 0.2(0.1) A
222.3 222.4 	 /  Control of external heat generators and 1 high limit safety cut-out each (on site, max. 70 °C), to switch off or switch between the following components: Central heating: <ul style="list-style-type: none"> Secondary pump, heat pump External heat generator DHW reheating: <ul style="list-style-type: none"> 3-way diverter valve "Central heating/DHW heating" 	Floating contact Connection values (contact load) <ul style="list-style-type: none"> Voltage: 230 V~ (not suitable for safety LV) Max. switching current: 4(2) A Connections for high limit safety cut-outs Central heating: <ul style="list-style-type: none"> In series to the secondary pump (terminal 211.2 on the main PCB) In series for controlling the external heat generator (terminal 222.3) DHW reheating: <ul style="list-style-type: none"> In series to 3-way diverter valve "Central heating/DHW heating" (terminal 211.4 on the main PCB)





Plug 223

Terminals	Function	Explanation
223.1 223.2 	Central fault message	Floating contact: <ul style="list-style-type: none"> Closed: Fault Open: No fault Not suitable for safety LV Connection values (contact load) <ul style="list-style-type: none"> Voltage: 230 V~ Max. switching current: 4(2) A



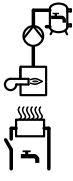

Plug 224

Terminals	Function	Explanation
224.4 	Instantaneous heating water heater switching, stage 2.	Connection values <ul style="list-style-type: none"> Output: 10 W Voltage: 230 V~ Max. switching current: 4(2) A
224.6  	 Cylinder loading pump (DHW side)  2-way shut-off valve	Connect cylinder loading pump and 2-way shut-off valve in parallel. Connection values <ul style="list-style-type: none"> Output: 130 W Voltage: 230 V~ Max. switching current: 4(2) A

Main and expansion PCB (cont.)

Terminals	Function	Explanation
224.7 	 /  Circulation pump for DHW reheating or  /  Control of immersion heater (in DHW cylinder)	Connection values <ul style="list-style-type: none"> ▪ Output: 100 W ▪ Voltage: 230 V~ ▪ Max. switching current: 4(2) A

Plug 225

Terminals	Function	Explanation
225.1 M2 	Heating circuit pump of the heating circuit with mixer M2/HC2	Connect a temperature limiter to restrict the maximum temperature for underfloor heating circuits (if installed) in series. Connection values <ul style="list-style-type: none"> ▪ Output: 100 W ▪ Voltage: 230 V~ ▪ Max. switching current: 4(2) A
225.2 M2  ▼ 	Mixer motor control, heating circuit M2/HC2 Signal mixer CLOSE ▼	Connection values <ul style="list-style-type: none"> ▪ Output: 10 W ▪ Voltage: 230 V~ ▪ Max. switching current: 0.2(0.1) A
225.3 M2  ▲ 	Mixer motor control, heating circuit M2/HC2 Signal mixer OPEN ▲	Connection values <ul style="list-style-type: none"> ▪ Output: 10 W ▪ Voltage: 230 V~ ▪ Max. switching current: 0.2(0.1) A

Main and expansion PCB (cont.)

Connections for DHW heating

Vitocal 100-S/200-A/200-S

211.4 (main PCB)

- 3-way diverter valve (B) (integral)
- Cylinder loading pump (C)
- 2-way shut-off valve (D)

Scheme

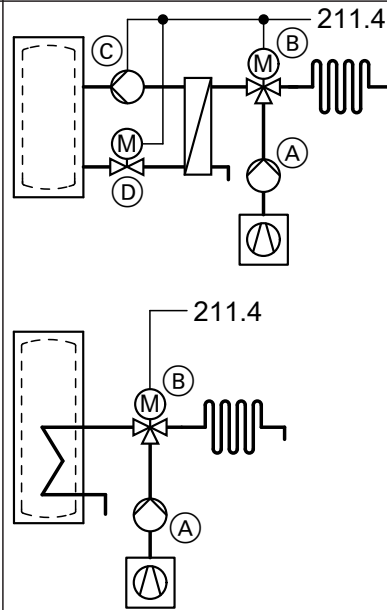

(A) Secondary pump (integral)

Vitocal 111-S/222-A/222-S/222-G/333-G

211.4 (main PCB)

- 3-way diverter valve (B) (integral)

Scheme

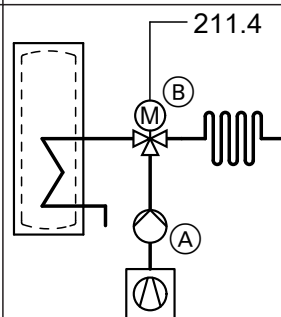

(A) Secondary pump (integral)

Main and expansion PCB (cont.)

Vitocal 300-A, type AWO-AC 301.B, Vitocal 300-A, type AWO 302.B

211.4 (main PCB)	224.6 (expansion PCB)	Scheme
<p>Circulation pump for cylinder heating (E)</p>	<ul style="list-style-type: none"> ▪ Cylinder loading pump (C) ▪ 2-way shut-off valve (D) 	<p>or</p> <p>(A) Secondary pump</p>

Vitocal 300-A cross connect PCB

For allocation to heat pump type: See "Overview of PCBs".

Message and safety connections

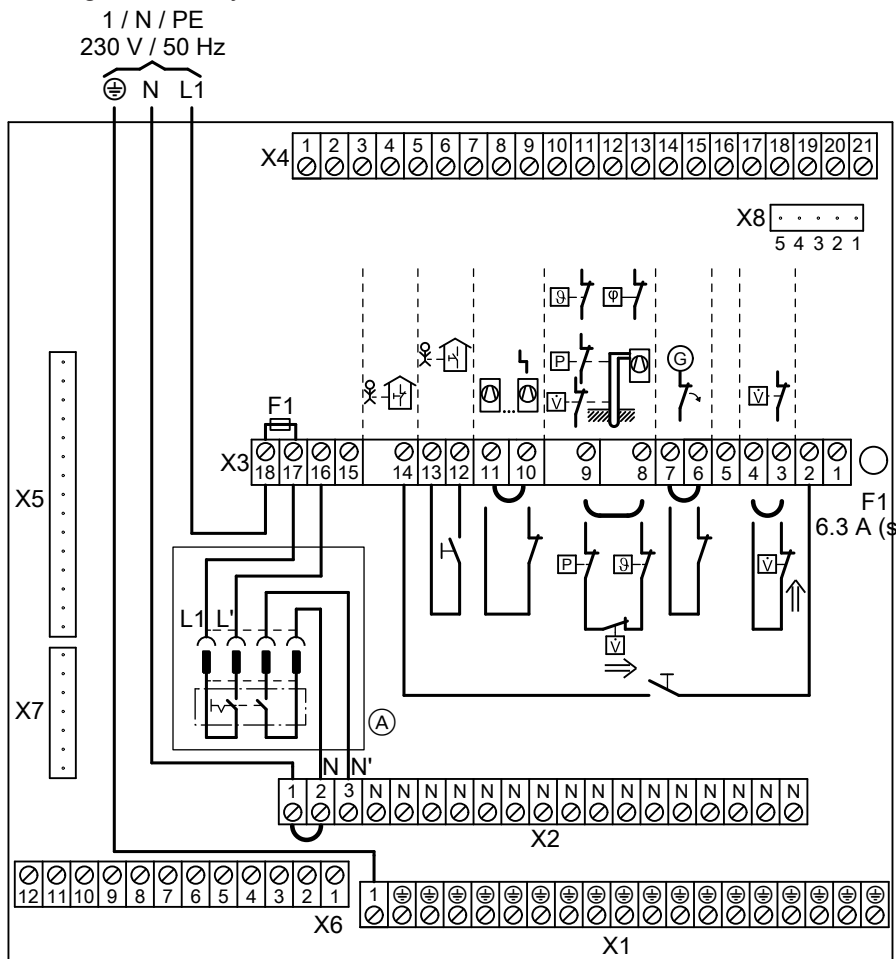











Fig. 66

- Ⓐ Plug-in connection ON/OFF switch (not on cross connect PCB)
- F1 Fuse 6.3 A (slow)
- X1 Terminals X1.⊕ for earth conductors of **all** associated system components
- X2 Terminals X2.N for neutral conductors of **all** associated system components
- X3
 - Terminals for control unit power supply "L1" and auxiliary components
 - Switched phase L1: X3.1, X3.2, X3.3, X3.7, X3.11, X3.13, X3.16
 - Terminals for message and safety connections
- X5/X7 Terminals for connecting cable (230 V~ control cable) to the heat pump
- X6/X8 Internally assigned terminals

Vitocal 300-A cross connect PCB (cont.)

Terminals	Function	Explanation
X3.1, X3.2, X3.3, X3.7, X3.11, X3.13, X3.16	Switched phase	Note <i>Observe the total load of 1000 W for all connected components.</i>
X3.2 X3.14 	"External blocking" signal: External blocking of compressor and pumps, mixer in control mode or CLOSE	Requires floating contact: <ul style="list-style-type: none"> ▪ Closed: Blocking active ▪ Open: No blocking ▪ Breaking capacity 230 V~, 2 mA Note <ul style="list-style-type: none"> ▪ <i>These and further external functions (such as provision of external set values) can alternatively be connected via the external EA1 extension (not in conjunction with Smart Grid).</i>  "EA1 extension" installation instructions
X3.3 X3.4 	Flow switch, secondary circuit	Requires floating contact: <ul style="list-style-type: none"> ▪ Closed: Heat pump operational ▪ Open: Heat pump shut down ▪ Breaking capacity 230 V~, 0.15 A <ul style="list-style-type: none"> ▪ Jumper is used in some devices. ▪ No jumper should be installed if a flow switch is connected.
X3.6 X3.7 	Power-OFF	Requires floating contact: <ul style="list-style-type: none"> ▪ Closed: No blocking (safety chain continuous) ▪ Open: Blocking active ▪ Breaking capacity 230 V~, 0.15 A Note <ul style="list-style-type: none"> ▪ <i>No parameters need to be set</i> ▪ No jumper should be installed if a power-OFF contact is connected. ▪ <i>The compressor is "forced" off as soon as the contact opens.</i> ▪ <i>The power-OFF signal switches off the supply voltage of the respective component (subject to the power supply utility).</i> ▪ <i>For the instantaneous heating water heater, the stages to be switched off can be selected (parameter "Output for instant. heating water heater at power-OFF 790A").</i> ▪ <i>The power supply for the heat pump control unit (3 x 1.5 mm²) and the cable for the power-OFF signal can be combined in a single 5-core cable.</i> In connection with Smart Grid: <i>The power-OFF signal must not be connected. Jumper must be installed.</i>

Vitocal 300-A cross connect PCB (cont.)

Terminals	Function	Explanation
X3.8 X3.9  	Frost stat and/or Contact humidistat or Jumper	Requires floating contact: <ul style="list-style-type: none"> ▪ Closed: Safety chain has continuity ▪ Open: Safety chain interrupted; heat pump shut down ▪ Breaking capacity 230 V~, 0.15 A <ul style="list-style-type: none"> ▪ Connected in series if more than one safety component is installed ▪ Insert jumper if no safety components are installed.
X3.10 X3.11  	Fault message, lag heat pump in a cascade or Jumper	Requires floating contact: <ul style="list-style-type: none"> ▪ Closed: No fault ▪ Open: Fault ▪ Breaking capacity 230 V~, 0.15 A <p>No jumper should be installed if a message contact is connected.</p>
X3.12 X3.13 	"External demand" signal: External starting of compressor and pumps, mixer in control mode or OPEN, changeover of the operating status of several system components	Requires floating contact: <ul style="list-style-type: none"> ▪ Closed: Demand ▪ Open: No demand ▪ Breaking capacity 230 V, 2 mA <p>Note</p> <ul style="list-style-type: none"> ▪ <i>These and further external functions (such as provision of external set values) can alternatively be connected via the external EA1 extension (not in conjunction with Smart Grid).</i> <p> "EA1 extension" installation instructions</p>
X3.17 X3.18	Fuse F1 6.3 A (slow)	
X3.18	Heat pump control unit power supply: Phase L1 X1.1 Earth conductor terminal X2.1 Neutral conductor terminal	Power supply 230 V~

Luster terminals, Vitocal 100-S/200-A/200-S

Signal and safety connections and components
230 V~

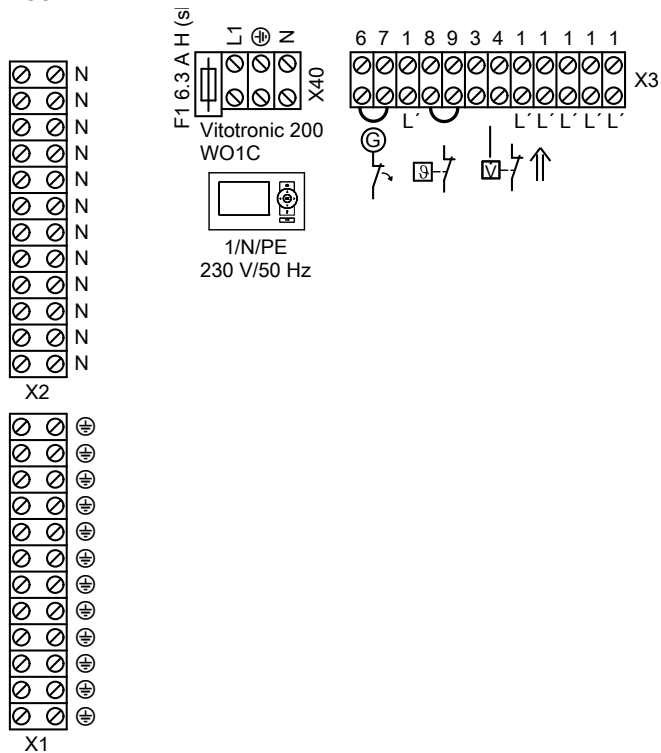



Fig. 67

- F1 Fuse 6.3 A (slow)
- X1 Terminals X1.⊕ for earth conductors of **all** associated system components
- X2 Terminals X2.N for neutral conductors of **all** associated system components
- X3
 - Switched phase L1: X3.1
 - Terminals for signal and safety connections and components 230 V~
- X40 Mains terminals for control unit power supply

Terminals	Function	Explanation
X3.1	Switched phase	Note <i>Observe the total load 1000 W of all connected components.</i>
X3.3 X3.4	Flow switch	Requires floating contact: <ul style="list-style-type: none"> ▪ Closed: Heat pump operational ▪ Open: Heat pump shut down ▪ Breaking capacity 230 V, 0.15 A No jumper should be installed if a flow switch is connected.
X3.6 X3.7	Power-OFF	Requires floating contact: <ul style="list-style-type: none"> ▪ Closed: Heat pump operational ▪ Open: Heat pump shut down ▪ Breaking capacity 230 V, 0.15 A

Luster terminals, Vitocal 100-S/200-A/200-S (cont.)

Terminals	Function	Explanation
		<p>Note</p> <ul style="list-style-type: none"> ▪ No parameters need to be set ▪ No jumper should be installed if a power-OFF contact is connected. ▪ The compressor is "forced" off as soon as the contact opens. ▪ The power-OFF signal switches off the supply voltage of the respective component (subject to the power supply utility). ▪ For the instantaneous heating water heater, the stages to be switched off can be selected (parameter "Output for instant. water heater at power-OFF 790A"). ▪ The power supply for the heat pump control unit (3 x 1.5 mm²) and the cable for the power-OFF signal can be combined in a single 5-core cable. <p>In connection with Smart Grid: The power-OFF signal must not be connected. Jumper must be fitted.</p>
X3.8 X3.9 	Frost stat, cooling or Jumper	Requires floating contact: <ul style="list-style-type: none"> ▪ Closed: Safety chain has continuity ▪ Open: Safety chain interrupted; heat pump shut down ▪ Breaking capacity 230 V~, 0.15 A <ul style="list-style-type: none"> ▪ Connected in series if 2 safety components are installed ▪ Insert jumper if no safety components are installed.
X40.L1	Heat pump controller power supply: Phase L1 X40.⊕ Earth conductor connection X40.N Neutral conductor connection	Power supply 230 V~

Luster terminals, Vitocal 111-S/222-A/222-S

Signal and safety connections and 230 V~ components

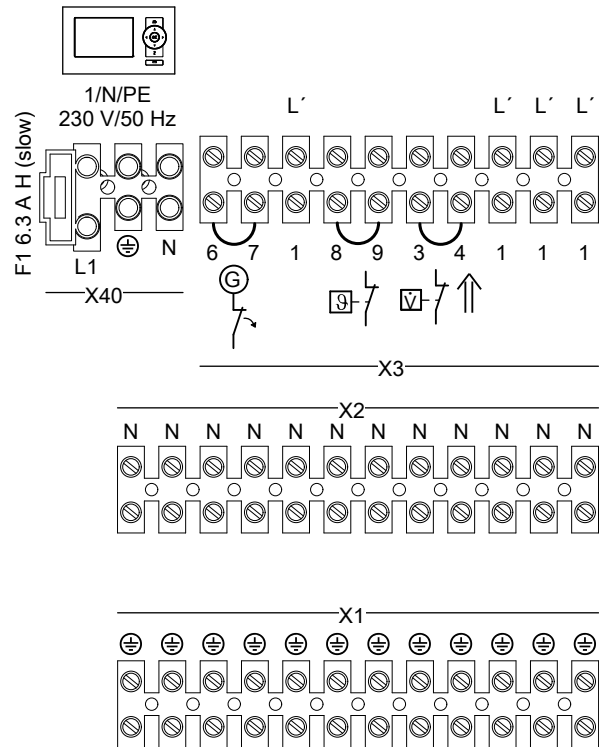





Fig. 68

- F1 Fuse 6.3 A H (slow)
- X1 Terminals X1.⊕ for earth conductors of **all** associated system components
- X2 Terminals X2.N for neutral conductors of **all** associated system components
- X3
 - Switched phase L': X3.1
 - Terminals for signal and safety connections and components 230 V~
- X40 Terminals for heat pump control unit power supply

Terminals	Function	Explanation
X3.1	Switched phase	Note Observe the total load 1000 W of all connected components.
X3.3 X3.4 	Flow switch	Requires floating contact: <ul style="list-style-type: none"> ▪ Closed: Heat pump operational ▪ Open: Heat pump shut down ▪ Breaking capacity 230 V, 0.15 A No jumper should be installed if a flow switch is connected.
X3.6 X3.7 	Power-OFF	Requires floating contact: <ul style="list-style-type: none"> ▪ Closed: Heat pump operational ▪ Open: Heat pump shut down ▪ Breaking capacity 230 V, 0.15 A

Luster terminals, Vitocal 111-S/222-A/222-S (cont.)

Terminals	Function	Explanation
		<p>Note</p> <ul style="list-style-type: none"> ▪ No parameters need to be set ▪ No jumper should be installed if a power-OFF contact is connected. ▪ The compressor is "forced" off as soon as the contact opens. ▪ The power-OFF signal switches off the supply voltage of the respective component (subject to the power supply utility). ▪ For the instantaneous heating water heater, the stages to be switched off can be selected (parameter "Output for instant. heating water heater at power-OFF 790A"). ▪ The power supply for the heat pump control unit (3 x 1.5 mm²) and the cable for the power-OFF signal can be combined in a single 5-core cable. <p>In connection with Smart Grid: The power-OFF signal must not be connected. Jumper must be installed.</p>
X3.8 X3.9 	Frost stat, cooling or Jumper	<p>Requires floating contact:</p> <ul style="list-style-type: none"> ▪ Closed: Safety chain has continuity ▪ Open: Safety chain interrupted; heat pump shut down ▪ Breaking capacity 230 V~, 0.15 A <ul style="list-style-type: none"> ▪ Connected in series if 2 safety components are installed ▪ Insert jumper if no safety components are installed.
X40.L1	Heat pump control unit power supply: Phase L1 X40.⊕ Earth conductor terminal X40.N Neutral conductor terminal	Power supply 230 V~

Luster terminals Vitocal 200-A

Signal and safety connections

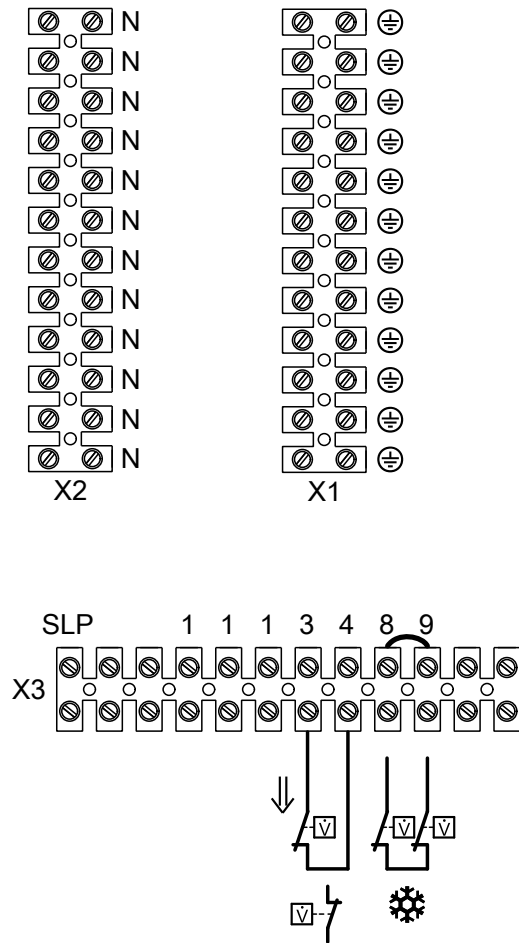

Fig. 69

- X1 Terminals X1.⊕ for earth conductors of **all** associated system components
- X2 Terminals X2.N for neutral conductors of **all** associated system components
- X3
 - Switched phase L1: X3.1, X3.2
 - Terminals for signal and safety connections

Luster terminals Vitocal 200-A (cont.)

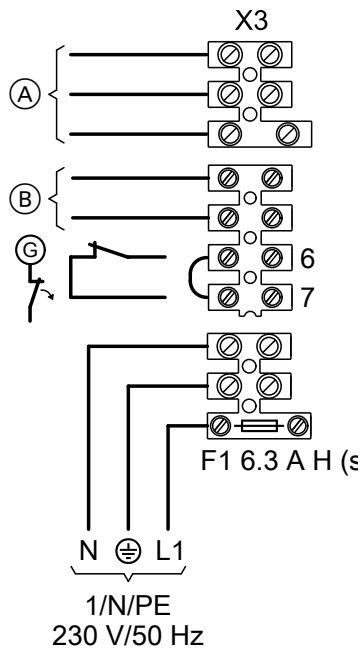



Fig. 70

F1 Fuse 6.3 A (slow)

- X3
- Fan connection 230 V~ (A) (factory-connected)
 - Fan thermal contact (B) (factory-connected)
 - Power supply terminals of control unit "L1" and auxiliary components
 - Terminals for signal and safety connections

Terminals	Function	Explanation
X3.SLP	Cylinder loading pump	Connection values: <ul style="list-style-type: none"> ▪ Output: 130 W ▪ Voltage: 230 V~ ▪ Max. switching current: 4(2) A
X3.1 X3.2	Switched phase	Note <i>Observe the total load 1000 W of all connected components.</i>
X3.3 X3.4	Flow switch	Requires floating contact: <ul style="list-style-type: none"> ▪ Closed: Heat pump in operation ▪ Open: Heat pump shut down ▪ Breaking capacity 230 V, 0.15 A <p>No jumper should be installed if a flow switch is connected.</p>
X3.6 X3.7	Power-OFF	Requires floating contact: <ul style="list-style-type: none"> ▪ Closed: No power-OFF (safety chain has continuity) ▪ Open: Power-OFF enabled ▪ Breaking capacity 230 V, 0.15 A

Luster terminals Vitocal 200-A (cont.)

Terminals	Function	Explanation
		<p>Note</p> <ul style="list-style-type: none"> ▪ No parameters need to be set ▪ No jumper should be installed if a power-OFF contact is connected. ▪ The compressor is "forced" off as soon as the contact opens. ▪ The power-OFF signal switches off the supply voltage of the respective operating component (subject to the power supply utility). ▪ For the instantaneous heating water heater, the stages to be switched off can be selected (parameter "Output for instant. heating water heater at power-OFF 790A"). ▪ The power supply for the heat pump control unit (3 x 1.5 mm²) and the cable for the power-OFF signal can be combined in a single 5-core cable. <p>In connection with Smart Grid: The power-OFF signal must not be connected. Jumper must be fitted.</p>
X3.8 X3.9 	Frost stat and/or contact humidistat or Jumper	Requires floating contact: <ul style="list-style-type: none"> ▪ Closed: Safety chain has continuity ▪ Open: Safety chain interrupted; heat pump shut down ▪ Breaking capacity 230 V~, 0.15 A <ul style="list-style-type: none"> ▪ Connected in series if both safety components are installed ▪ Insert jumper if no safety components are installed.
X3.18	Heat pump control unit power supply: Phase L1 X1.1 Earth conductor connection X2.1 Neutral conductor connection	Power supply 230 V~

Vitocal 222-G/333-G luster terminals

Signal and safety connections and 230 V~ components

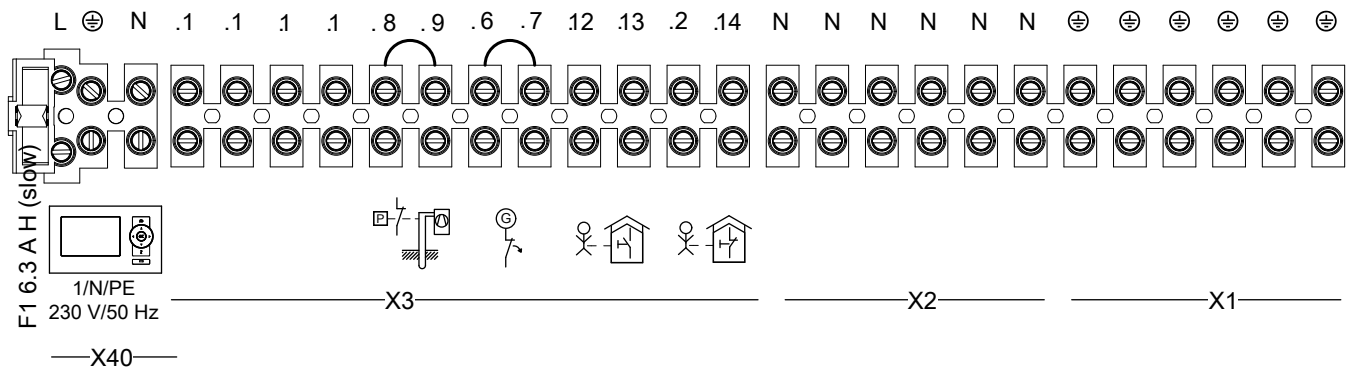
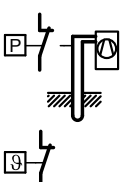

Fig. 71

- F1 Fuse 6.3 A H (slow)
- X1 Terminals X1.⊕ for earth conductors of **all** associated system components
- X2 Terminals X2.N for neutral conductors of **all** associated system components
- X3
 - Switched phase L': X3.1
 - Terminals for signal and safety connections and components 230 V~
- X40 Terminals for heat pump control unit power supply

Terminals	Function	Explanation
X3.1	Switched phase	<p>Note</p> <p>Observe the total load 1000 W of all connected components.</p>
X3.6 X3.7	Power-OFF	<p>Requires floating contact:</p> <ul style="list-style-type: none"> ▪ Closed: Heat pump operational ▪ Open: Heat pump shut down ▪ Breaking capacity 230 V, 0.15 A <p>Note</p> <ul style="list-style-type: none"> ▪ No parameters need to be set ▪ No jumper should be installed if a power-OFF contact is connected. ▪ The compressor is "forced" off as soon as the contact opens. ▪ The power-OFF signal switches off the supply voltage of the respective component (subject to the power supply utility). ▪ For the instantaneous heating water heater, the stages to be switched off can be selected (parameter "Output for instant. heating water heater at power-OFF 790A"). ▪ The power supply for the heat pump control unit (3 x 1.5 mm²) and the cable for the power-OFF signal can be combined in a single 5-core cable. <p>In connection with Smart Grid:</p> <p>The power-OFF signal must not be connected. Jumper must be installed.</p>

Vitocal 222-G/333-G luster terminals (cont.)

Terminals	Function	Explanation
X3.8 X3.9 	Pressure switch, primary circuit and/or Frost stat or Jumper	Requires floating contact: <ul style="list-style-type: none"> ▪ Closed: Safety chain has continuity ▪ Open: Safety chain interrupted; heat pump shut down ▪ Breaking capacity 230 V~, 0.15 A <ul style="list-style-type: none"> ▪ Connected in series if 2 safety components are installed ▪ Insert jumper if no safety components are installed.
X40.L1 X40.⊕ Earth conductor terminal X40.N Neutral conductor terminal	Heat pump control unit power supply: Phase L1 X40.⊕ Earth conductor terminal X40.N Neutral conductor terminal	Power supply 230 V~

Vitocal 100-S/200-A/200-S/300-A controller and sensor PCB

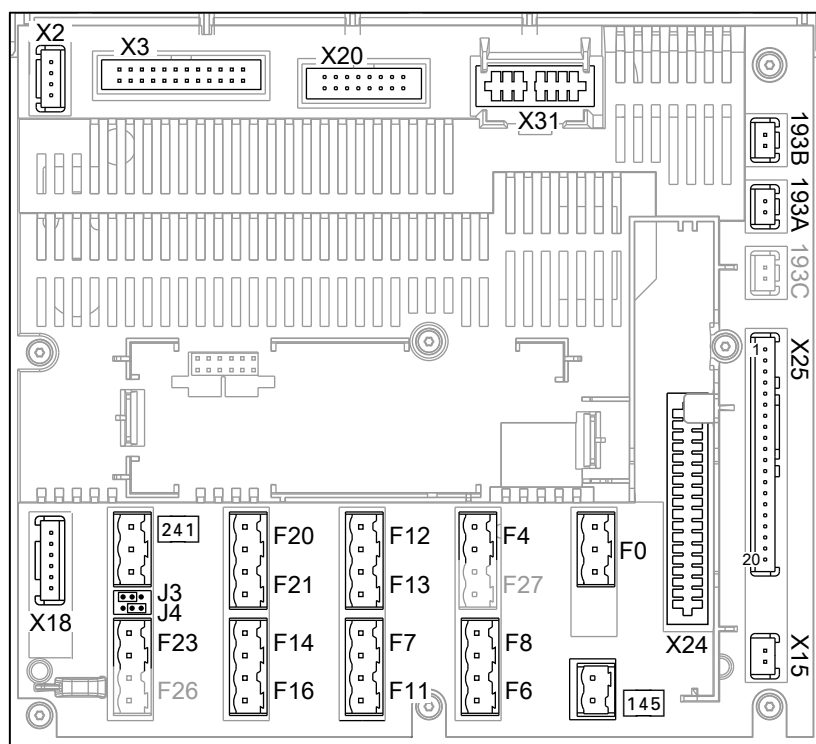

Fig. 72

- | | | | |
|-----|---|-----|--|
| F.. | Connections for temperature sensors: See the following table. | X18 | Modbus 1 connection: Viessmann appliances, e.g. outdoor unit |
| J3 | Jumper for Modbus 2 terminator | X20 | Programming unit connection |
| | <ul style="list-style-type: none"> ▪ Terminator active • Terminator not active | X24 | Slot for LON communication module |
| J4 | Jumper for setting master/slave, Modbus 2 | X25 | <ul style="list-style-type: none"> ⊗ Connections for sensors and components ⊗ Connections for connecting cable (LV) to the heat pump control panel or wiring chamber |
| | <ul style="list-style-type: none"> ▪ Heat pump control unit is slave. • Heat pump control unit is master. | X31 | Slot for coding card |
| X2 | Connection, power supply to main PCB | 145 | KM-BUS |
| X3 | Connection, connecting cable to main PCB | | |
| X15 | Internal connection, KM-BUS | | |

Vitocal 100-S/200-A/200-S/300-A controller and... (cont.)

- 193 A Connection, PWM signal
 193 B Connection, PWM signal, secondary pump
 241 Modbus 2 connection, e.g. energy meter

Sensors F0 to F25: See inscription on the sensor

Sensor	Connection at plug X25	Sensor/component	Type
F0.1/F0.2	—	Outside temperature sensor	NTC 10 kΩ
F0.2/F0.3	—	Radio clock receiver (accessories)	DCF
F3	X25.3/X25.4	Vitocal 100-S/200-S only: Secondary circuit flow temperature sensor upstream of instantaneous heating water heater	Pt500A (PTC)
F4	—	Buffer temperature sensor	NTC 10 kΩ
F6	X25.5/X25.6	Cylinder temperature sensor, top	NTC 10 kΩ
F7	X25.7/X25.8	Cylinder temperature sensor, bottom	NTC 10 kΩ
F8	X25.9/X25.10	Secondary circuit flow temperature sensor	Pt500A (PTC)
F9	X25.11/X25.12	Secondary circuit return temperature sensor	Pt500A (PTC)
F11	—	Contact humidistat 24 V~ Note <i>If a 230 V~ contact humidistat (connection to X3.8/X3.9) is used for cooling, insert a jumper, otherwise the heat pump will not start (message "CA Protectn device primry").</i> Note <i>System with heating water/coolant buffer cylinder:</i> <ul style="list-style-type: none"> ▪ If cooling is performed via several heating/cooling circuits, provide a contact humidistat for each heating/cooling circuit. ▪ Connect several contact humidistats in series. 	—
F12	—	Flow temperature sensor, heating circuit with mixer M2/HC2	NTC 10 kΩ
F13	—	System flow temperature sensor, with sensor well, downstream of heating water buffer cylinder	NTC 10 kΩ
F14	—	Flow temperature sensor, cooling circuit (without buffer cylinder, heating circuit without mixer A1/HC1 or separate cooling circuit SKK)	NTC 10 kΩ
F16	—	Room temperature sensor for separate cooling circuit	NTC 10 kΩ
F20	—	Boiler water temperature sensor, external heat generator	NTC 10 kΩ
F21	—	Heat pump cascade: Flow temperature sensor, swimming pool	NTC 20 kΩ
F23	—	Heat pump cascade: Buffer outlet temperature sensor	NTC 10 kΩ
F24	X25.15/X25.16	Vitocal 100-S/200-S only: Reversible suction gas temperature sensor	Pt500A (PTC)
F25	X25.17/X25.18	Vitocal 100-S/200-S only: Liquid gas temperature sensor	Pt500A (PTC)

Factory-fitted

For temperature sensor parameters: See page 314.

Vitocal 111-S/222-A/222-S/222-G/333-G controller and sensor PCB

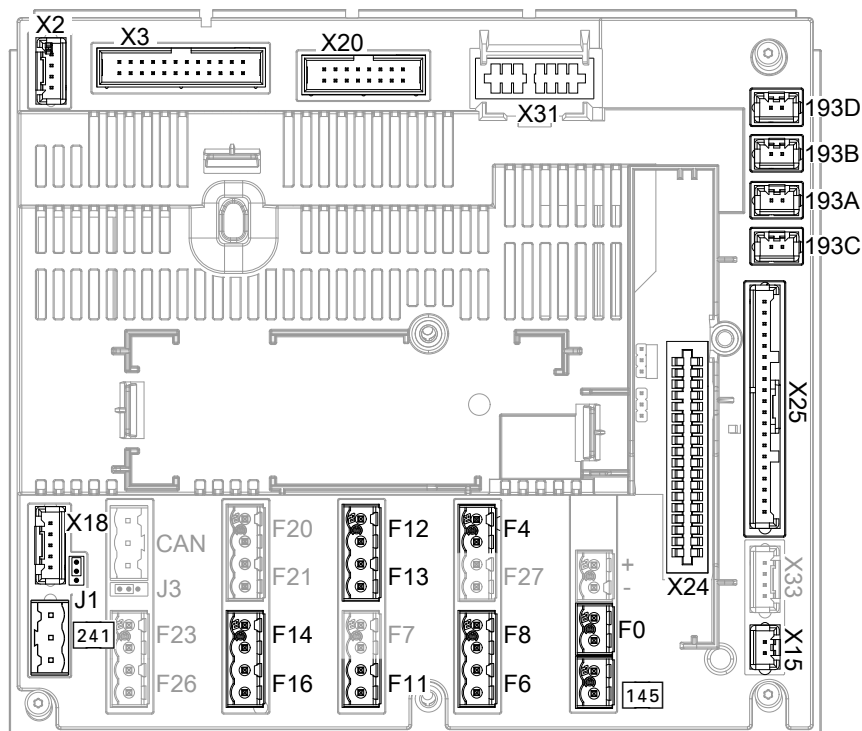



Fig. 73

- F.. For temperature sensors: See the following table.
- J1 Jumper for Modbus terminator
 Terminator active
 Terminator not active
- X2 Power supply to main PCB
 X3 Connecting cable to main PCB
 X15 KM-BUS (internal connection)
 X18 Modbus, e.g. outdoor unit:
 If several appliances are to be connected, use the Modbus distributor (accessories).
- X20 Programming unit
 X24 Slot for LON communication module
 X25 Sensors and components
- X31 Slot for coding card
 145 KM-BUS
 193 A Vitocal 111-S/222-A/222-S only:
 PWM signal, heating circuit pump M2/HC2
 (component of installation kit with mixer, accessories)
 193 B Vitocal 111-S/222-A/222-S only:
 PWM signal, secondary pump
 193 C PWM signal, cylinder loading pump
 193 D PWM signal, solar circuit pump
 241 Modbus, e.g. energy meter:
 If several appliances are to be connected, use the Modbus distributor (accessories).

Sensors F0 to F25: See inscription on the sensor

Sensor	Connection at plug X25	Sensor/component	Type
F0	—	Outside temperature sensor	NTC 10 kΩ
F3	X25.3/X25.4	Vitocal 111-S/222-S only: Secondary circuit flow temperature sensor upstream of instantaneous heating water heater	Pt500A (PTC)
F4	—	Buffer temperature sensor	NTC 10 kΩ
F6	X25.5/X25.6	Cylinder temperature sensor	NTC 10 kΩ
F8	X25.9/X25.10	Vitocal 111-S/222-A/222-S only: Secondary circuit flow temperature sensor	Pt500A (PTC)
F9	X25.11/X25.12	Vitocal 111-S/222-A/222-S only: Secondary circuit return temperature sensor	Pt500A (PTC)

Vitocal 111-S/222-A/222-S/222-G/333-G controller and sensor PCB (cont.)

Sensor	Connection at plug X25	Sensor/component	Type
F11	—	Contact humidistat 24 V– Note If the following contact humidistats are used during cooling, insert jumper , otherwise the heat pump will not start (message " CA Protectn device primry "). ⊗□: Contact humidistat 230 V~: Connection to X3.8/X3.9 □: Contact humidistat 24 V–: Connection to NC-Box Note System with heating water/coolant buffer cylinder: ▪ If cooling is performed via several heating/cooling circuits, provide a contact humidistat for each heating/cooling circuit. ▪ Connect several contact humidistats in series.	—
F12	—	Flow temperature sensor, heating circuit with mixer M2/HC2	NTC 10 kΩ
F13	—	System flow temperature sensor, downstream of buffer cylinder	NTC 10 kΩ
F14	—	Flow temperature sensor, cooling circuit (without buffer cylinder, heating circuit without mixer A1/HC1 or separate cooling circuit SKK)	NTC 10 kΩ
F16	—	Room temperature sensor for separate cooling circuit	NTC 10 kΩ
F24	X25.15/X25.16	Vitocal 111-S/222-S only: Reversible suction gas temperature sensor	Pt500A (PTC)
F25	X25.17/X25.18	Vitocal 111-S/222-S only: Liquid gas temperature sensor	Pt500A (PTC)

 Factory-fitted

For temperature sensor parameters: See page 314.

EEV PCB [2]

For allocation to heat pump type: See "Overview of PCBs".

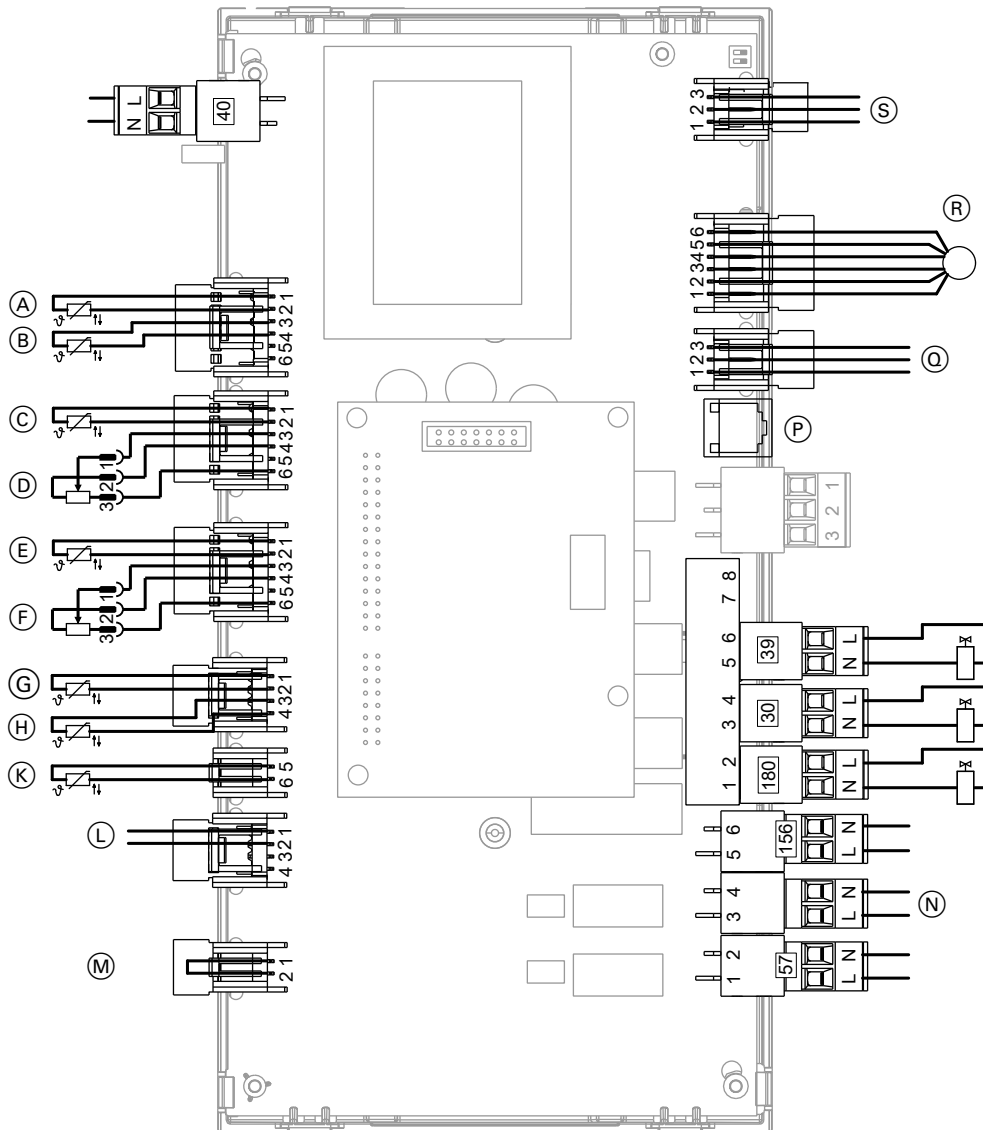

Fig. 74

- | | |
|---|---|
| <ul style="list-style-type: none"> (A) Air intake temperature sensor (Pt500A) (B) Air discharge temperature sensor (Pt500A) (C) Hot gas temperature sensor (Pt500A) (D) High pressure sensor (E) Suction gas temperature sensor (Pt500A) (F) Low pressure sensor (G) Liquid gas temperature sensor 1 (upstream of EEV), (Pt500A) (H) Liquid gas temperature sensor 2 (downstream of EEV), (Pt500A) (K) Return temperature sensor, secondary circuit, (Pt500A) (L) Fan control 0-10 V (M) Slot for jumper, master/slave
Jumper not plugged in: Refrigerant circuit in heat pump 1 (master)
Jumper plugged in: Refrigerant circuit in heat pump stage 2 (slave) | <ul style="list-style-type: none"> (N) Compressor control (P) Never connect anything here. (Q) Modbus: Connecting cable to the controller and sensor PCB, connection X18 (R) Stepper motor EEV (4 or 6-pole) (S) Connection for connecting cable to the inverter [30] Solenoid valve [38] Not allocated [39] Control of 4-way diverter valve [40] Internal power supply [57] Demand signal, refrigerant circuit reversal [156] Internal power supply [180] Control of solenoid valve, enhanced vapour injection (EVI) |
|---|---|

Inverter

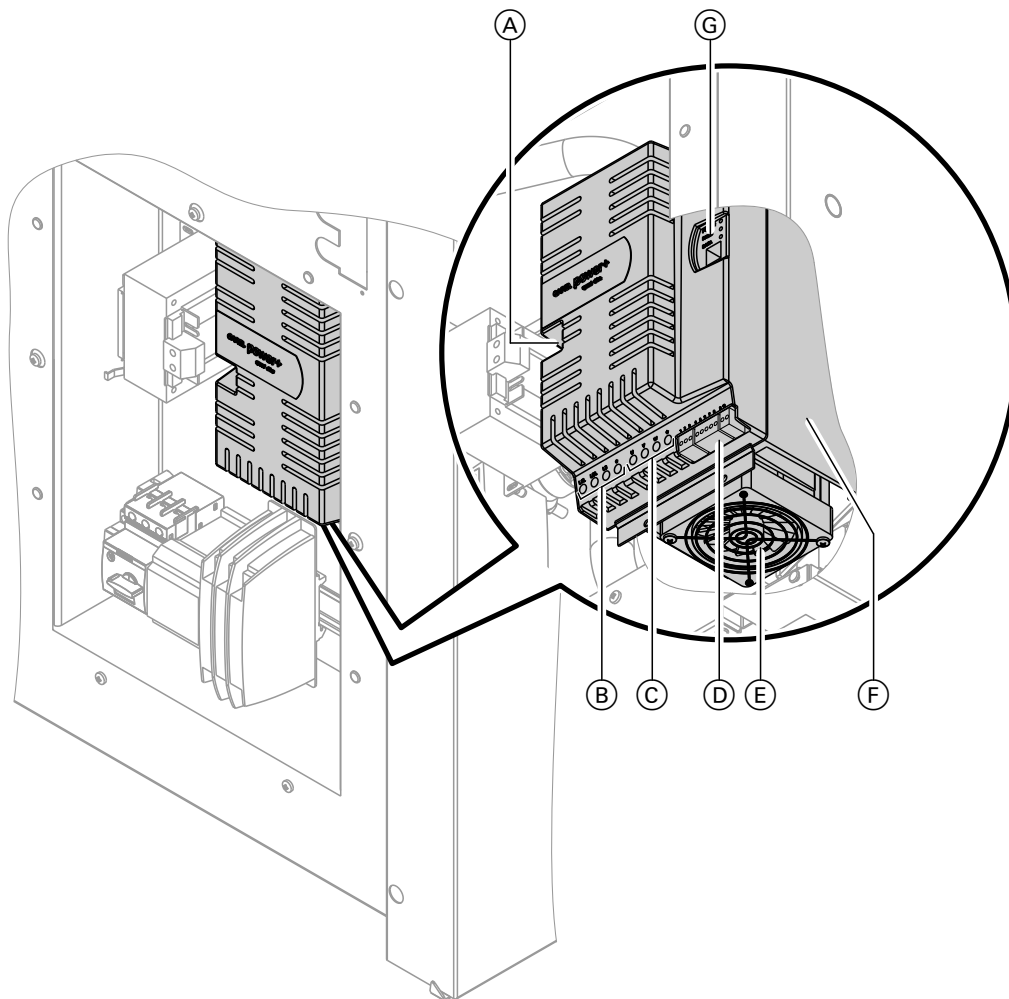

Fig. 75

- | | |
|--|--|
| <ul style="list-style-type: none"> Ⓐ Connection for coil Ⓑ Power supply terminals Ⓒ Terminals, connecting cable to the compressor Ⓓ Terminals <ul style="list-style-type: none"> 1 to 3 Connecting cable to the EEV PCB [2] 4 to 10 Jumpers, plugged in at the factory; never alter. | <ul style="list-style-type: none"> Ⓔ Fan Ⓕ Heat sink Ⓖ LED status indicators: <ul style="list-style-type: none"> "POWER" Inverter power supply connected. "FAULT" Inverter fault, compressor off "DATA" Flashes if data is received from EEV PCB. |
|--|--|

EEV PCB  [4]

For allocation to heat pump type: See "Overview of PCBs".

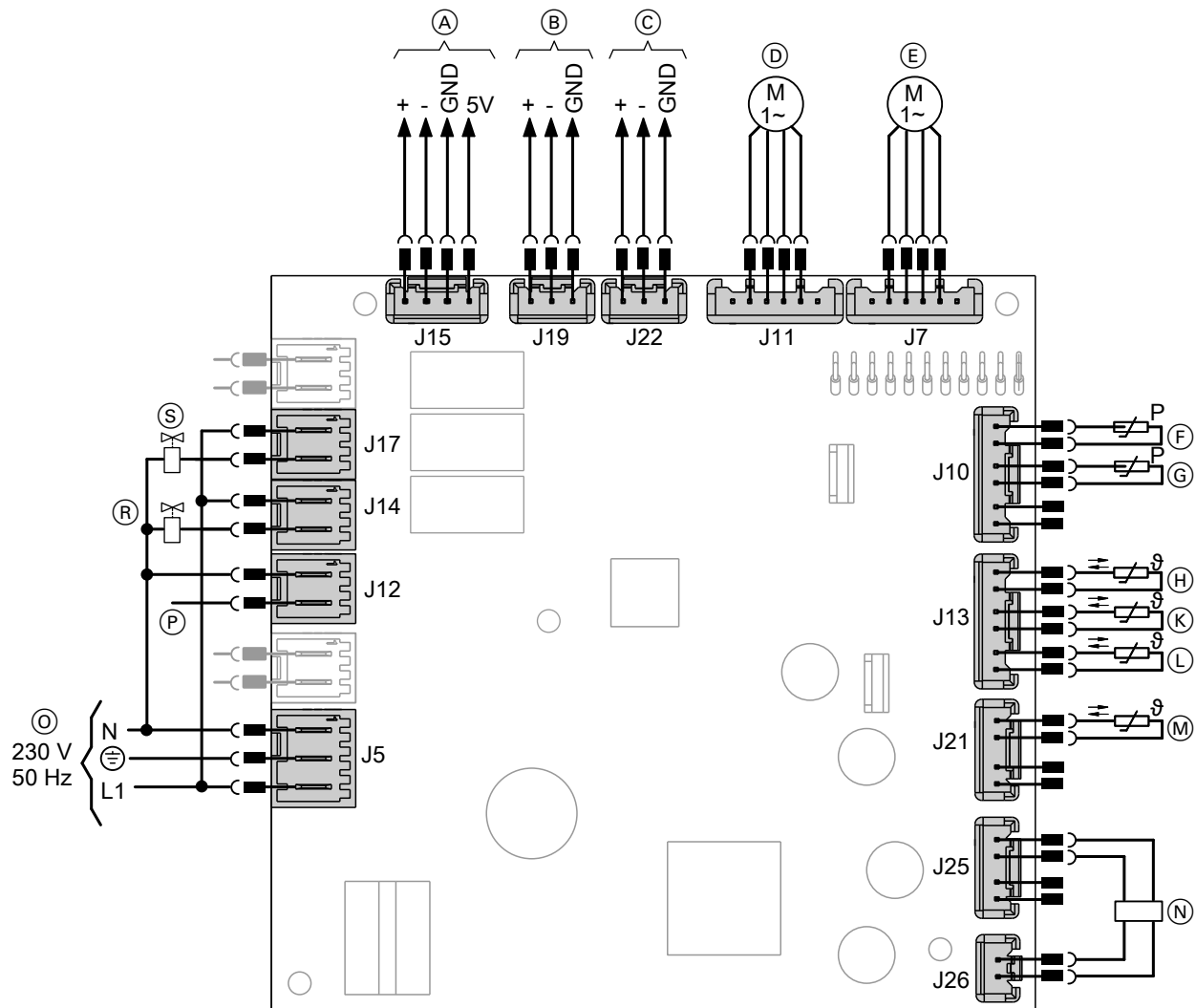

Fig. 76

- (A) Modbus: Inverter control
- (B) Modbus: Fan control
- (C) Modbus: Connecting cable to the controller and sensor PCB, connection X18
- (D) Electronic expansion valve for suction gas superheating (AHX)
- (E) Electronic expansion valve for refrigerant collector level control (PHX)
- (F) Low pressure sensor
- (G) High pressure sensor
- (H) Suction gas temperature sensor (upstream of compressor) (NTC 10 kΩ)
- (K) Liquid gas temperature sensor (downstream of condenser) (NTC 10 kΩ)
- (L) Liquid gas temperature sensor (downstream of refrigerant collector) (NTC 10 kΩ)
- (M) Suction gas temperature sensor (downstream of evaporator) (NTC 10 kΩ)
- (N) Refrigerant collector level sensor
- (O) Internal power supply (factory connection)
- (P) Digital input 230 V~
- (R) 4-way diverter valve
- (S) Intermediate injection solenoid valve

EEV PCB ☒ [4-3] / [4-4]

For allocation to heat pump type: See "Overview of PCBs".

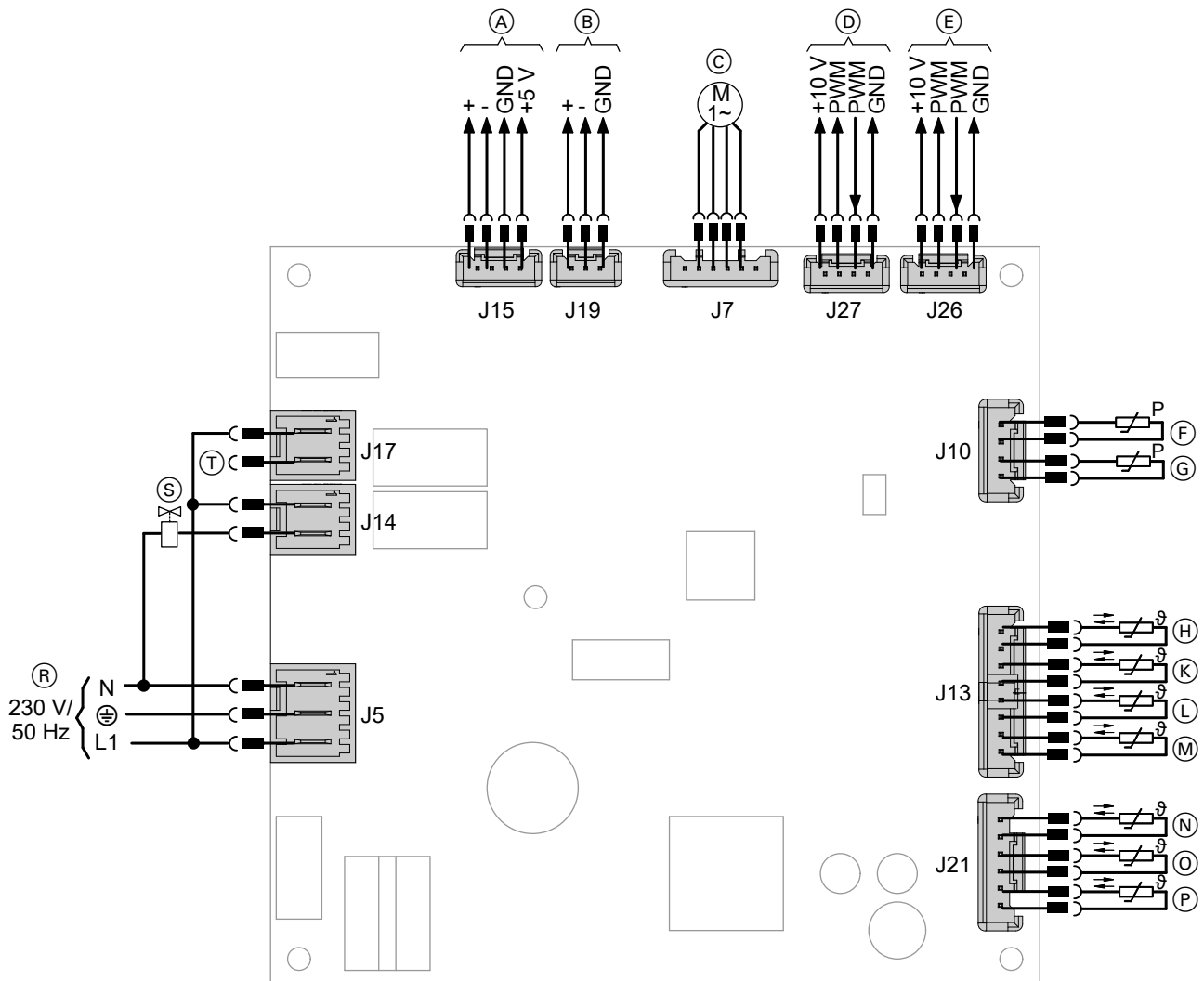

Fig. 77

- (A) Modbus: Inverter control
- (B) Modbus: Connecting cable to the controller and sensor PCB of the indoor unit, terminal X18
- (C) Electronic expansion valve
- (D) Fan control 1
- (E) Fan control 2 (if installed)
- (F) Low pressure sensor
- (G) High pressure sensor
- (H) Suction gas temperature sensor (upstream of compressor) (NTC 10 k Ω)
- (K) Air intake temperature sensor (NTC 10 k Ω)
- (L) Hot gas temperature sensor (NTC 10 k Ω)
- (M) Suction gas temperature sensor (downstream of evaporator) (NTC 10 k Ω)
- (N) Vitocal 200-A/222-A only:
Secondary circuit flow temperature sensor (NTC 10 k Ω)
- (O) Refrigerant circuit controller temperature sensor (NTC 10 k Ω)
- (P) Vitocal 200-A/222-A only:
LPG temperature sensor (NTC 10 k Ω)
- (R) Internal power supply (factory connection)
- (S) 4-way diverter valve
- (T) Ribbon heater for condensate pan

For allocation to heat pump type: See "Overview of PCBs".

[4-6]: Vitocal 333-G

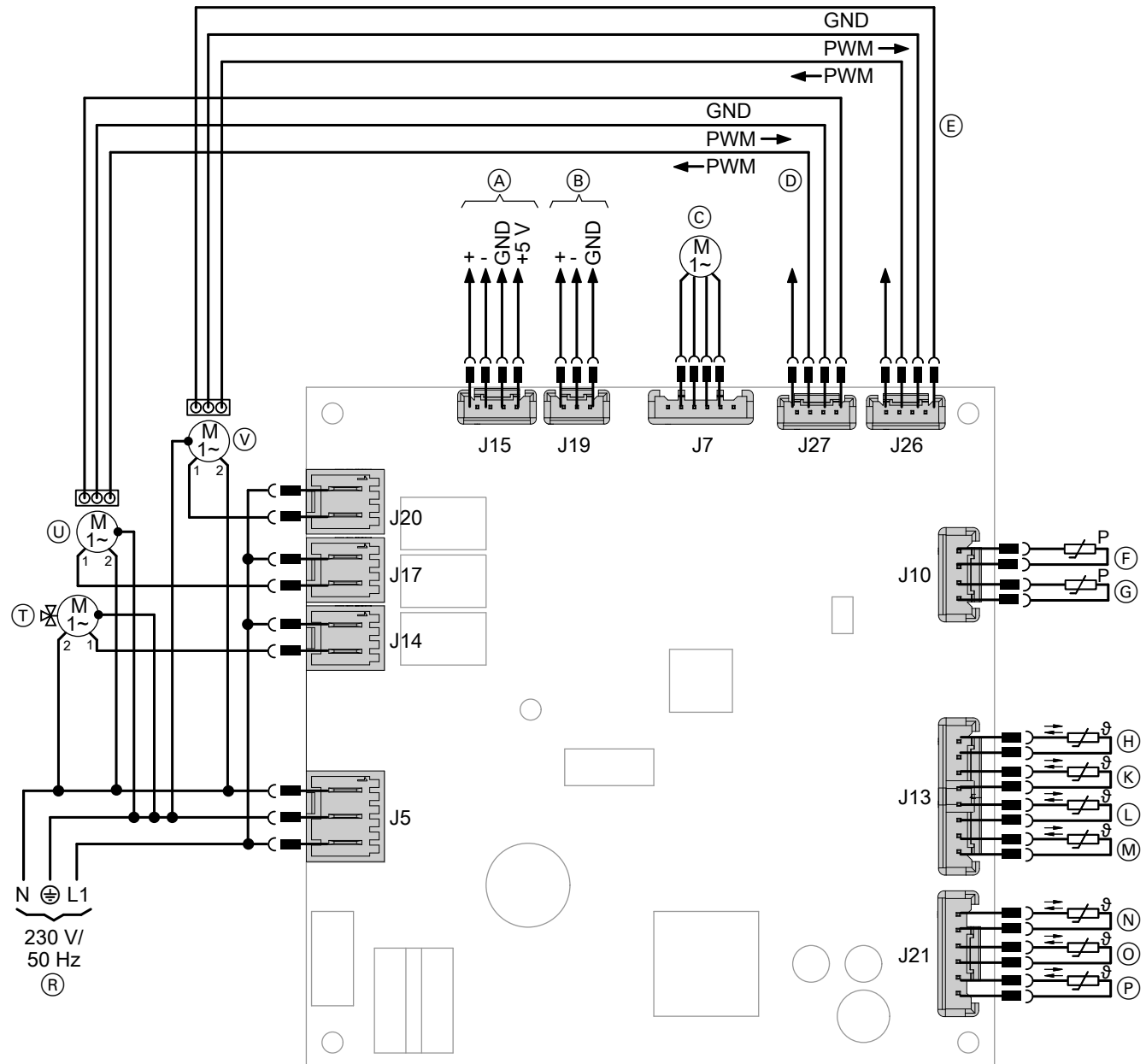

Fig. 78

- (A) Modbus: Inverter control
- (B) Modbus: Connecting cable to the controller and sensor PCB, terminal X18
- (C) Electronic expansion valve
- (D) PWM signal for primary pump
- (E) PWM signal, secondary pump
- (F) Low pressure sensor
- (G) High pressure sensor
- (H) Suction gas temperature sensor (NTC 10 kΩ)
- (K) Primary circuit flow temperature sensor (NTC 10 kΩ)
- (L) Hot gas temperature sensor (NTC 10 kΩ)
- (M) Liquid gas temperature sensor (NTC 10 kΩ)
- (N) Secondary circuit flow temperature sensor (NTC 10 kΩ)
- (O) Secondary circuit flow temperature sensor downstream of instantaneous heating water heater (NTC 10 kΩ)
- (P) Secondary circuit return temperature sensor (NTC 10 kΩ)
- (R) Internal power supply (factory connection)
- (T) "Central heating/DHW heating" 3-way diverter valve
- (U) Primary pump
- (V) Secondary pump

[4-7]: Vitocal 222-G

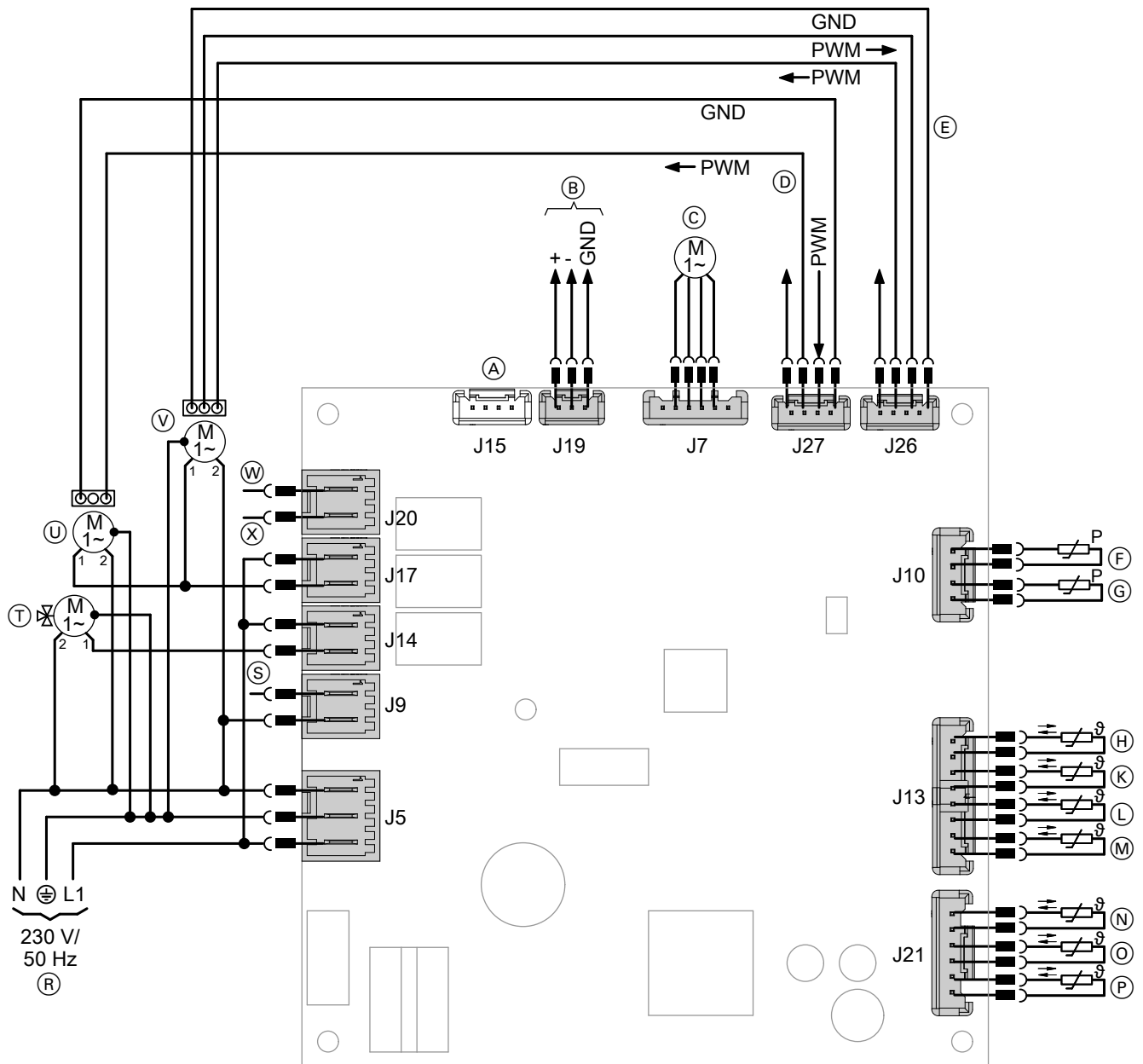

Fig. 79

- (A) Never connect anything here.
- (B) Modbus: Connecting cable to the controller and sensor PCB, terminal X18
- (C) Electronic expansion valve
- (D) PWM signal for primary pump
- (E) PWM signal, secondary pump
- (F) Low pressure sensor
- (G) High pressure sensor
- (H) Suction gas temperature sensor (NTC 10 k Ω)
- (K) Primary circuit flow temperature sensor (NTC 10 k Ω)
- (L) Hot gas temperature sensor (NTC 10 k Ω)
- (M) Liquid gas temperature sensor (NTC 10 k Ω)
- (N) Secondary circuit flow temperature sensor (NTC 10 k Ω)
- (O) Secondary circuit flow temperature sensor downstream of instantaneous heating water heater (NTC 10 k Ω)
- (P) Secondary circuit return temperature sensor (NTC 10 k Ω)
- (R) Internal power supply (factory connection)
- (S) Safety high pressure switch
- (T) "Central heating/DHW heating" 3-way diverter valve
- (U) Primary pump
- (V) Secondary pump
- (W) Compressor relay (230 V~)
- (X) Enable compressor switching

Controller PCB and EEV PCB ⓧ [6]

Controller PCB: Type AWO 301.A25 to A60

For allocation to heat pump type: See "Overview of PCBs".

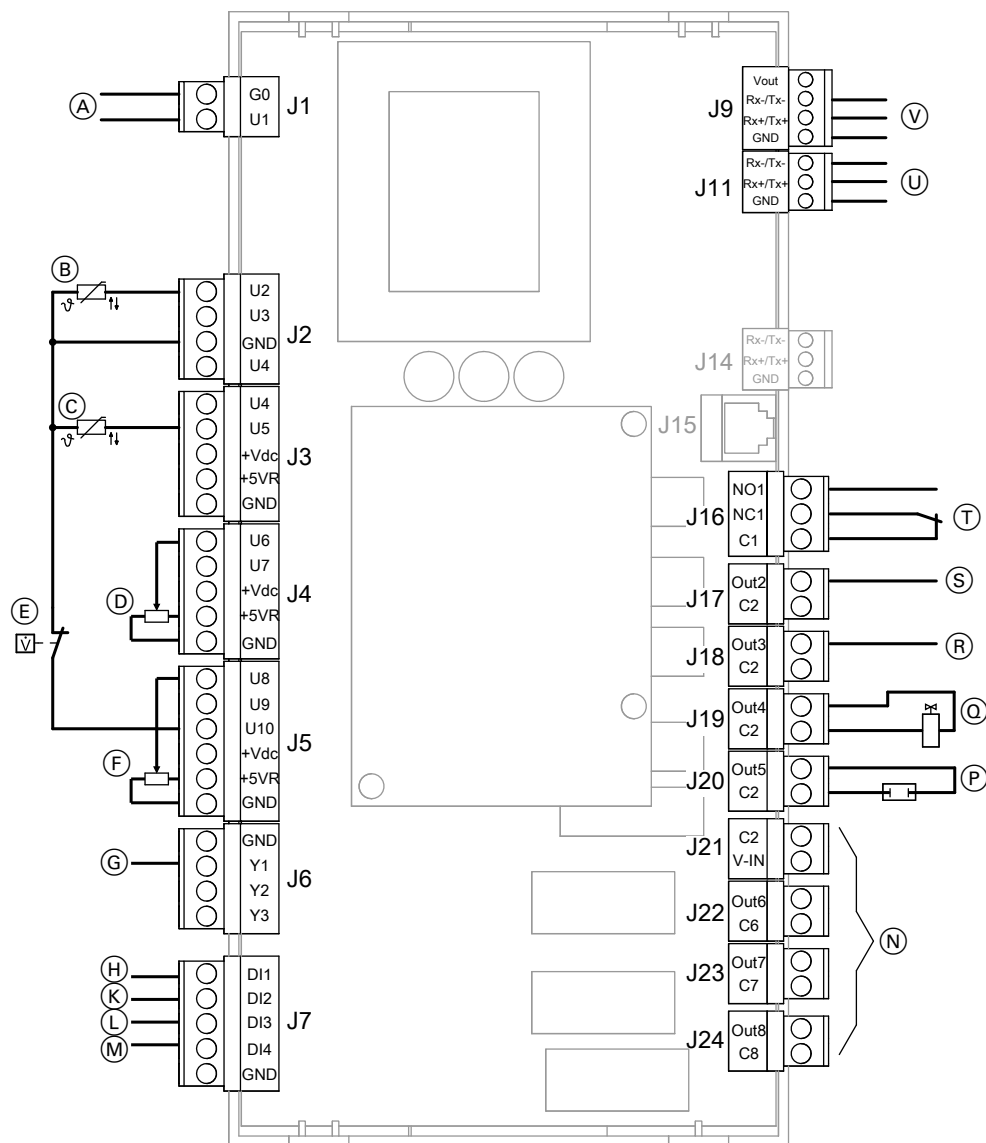

Fig. 80

- | | |
|---|---|
| (A) Power supply 230 V/50 Hz | (M) Low pressure switch |
| (B) Secondary circuit return temperature sensor (NTC 10 k Ω) | (N) Voltage 230 V~ |
| (C) Secondary circuit flow temperature sensor in the heat pump (NTC 10 k Ω) | (P) Type AWO 301.A25 and A40: Electric ribbon heater (oil sump heater) |
| (D) Type AWO 301.A25 and A40: Low pressure sensor | (Q) 4-way diverter valve |
| (E) Type AWO 301.A60: Flow switch | (R) Fan control |
| (F) High pressure sensor | (S) Compressor 2 control |
| (G) Fan PWM signal | (T) Compressor 1 control |
| (H) Fan status input | (U) Modbus connecting cable to the controller and sensor PCB, connection X18 |
| (K) Soft starter status input | (V) Type AWO 301.A60: Modbus connecting cable to the EEV PCB [6], connection (D) in Fig. 81 |
| (L) Circuit breaker status input | |

Controller PCB and EEV PCB ☒ [6] (cont.)

EEV PCB: Type AWO 301.A60

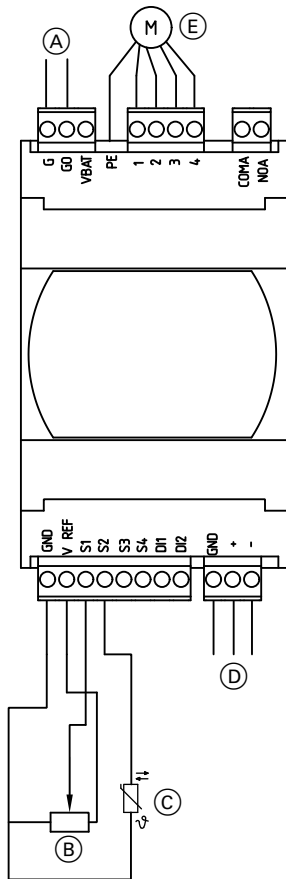

Fig. 81

- (A) Power supply 24 V–
- (B) Low pressure sensor
- (C) Suction gas temperature sensor (NTC 10 k Ω)
- (D) Modbus connecting cable to controller PCB, connection (V) in Fig. 80
- (E) Electronic expansion valve stepper motor

Main PCB ☒ [7] / [7-1]

For allocation to heat pump type: See "Overview of PCBs".

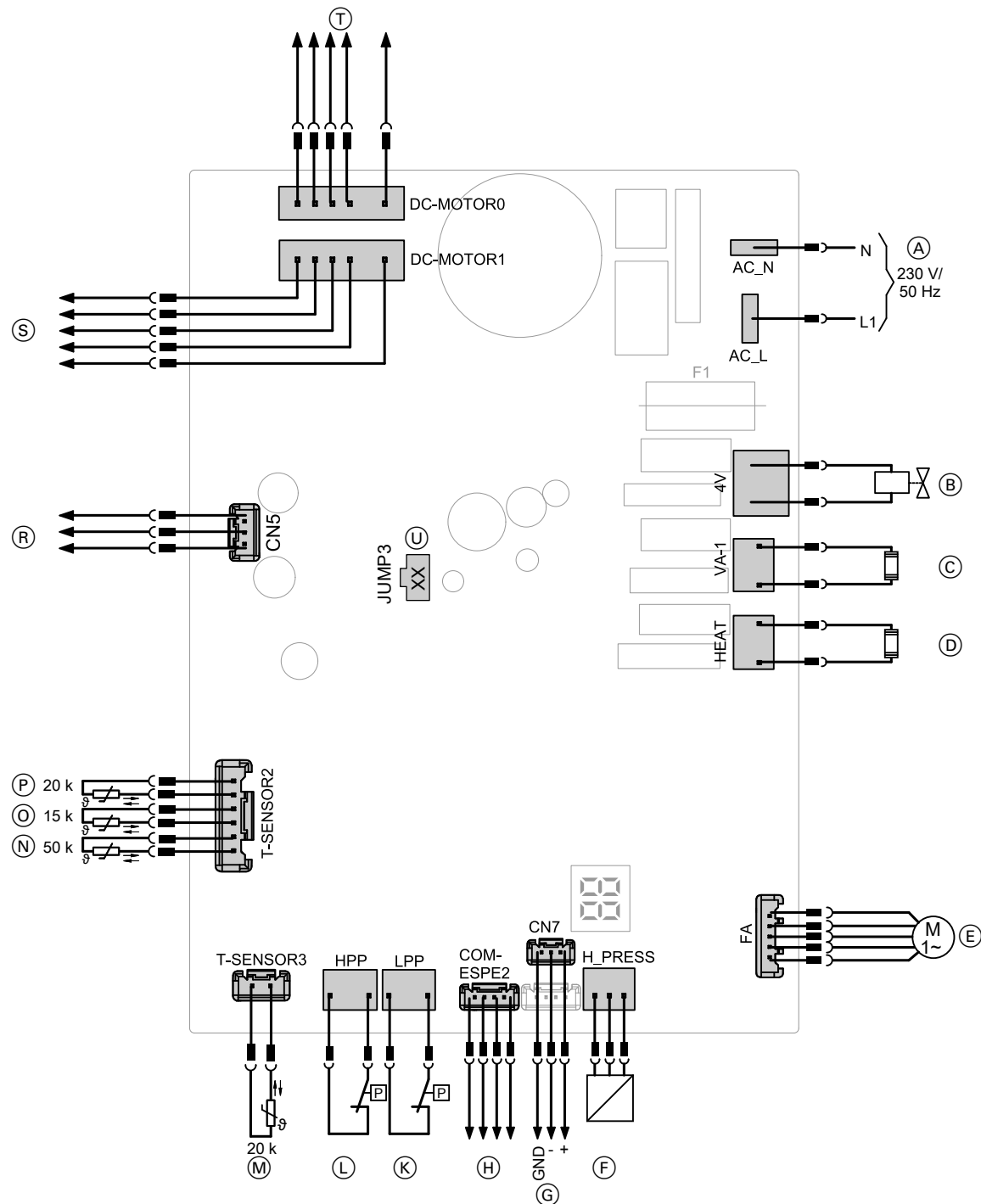

Fig. 82

- (A) Internal power supply (factory connection)
- (B) 4-way diverter valve
- (C) Ribbon heater, condensate pan
- (D) Oil sump heater
- (E) Electronic expansion valve
- (F) High pressure sensor
- (G) Modbus: Connecting cable to the controller and sensor PCB of the indoor unit, connection X18
- (H) Control of inverter
- (K) Low pressure switch
- (L) High pressure switch
- (M) Suction gas temperature sensor (NTC 20 kΩ)
- (N) Hot gas temperature sensor (NTC 50 kΩ)
- (P) Air intake temperature sensor (NTC 15 kΩ)
- (Q) Defrost temperature sensor (NTC 20 kΩ)
- (R) Inverter power supply
- (S) Fan control 2 (if installed)
- (T) Fan control 1
- (U) Jumper (blue) with printed ID (XX): See next chapter.

Main PCB  [7] / [7-1] (cont.)

Jumper ID (blue)

Types	Refrigerant circ controller	Printed ID (XX)
101/111.A04	[7]	05
	[7-1]	01
101/111.A06	[7]	06
	[7-1]	02
101/111.A08	[7]	09
	[7-1]	03
101/111.A12	[7]	08
	[7-1]	04
101/111.A14	[7]	07
	[7-1]	10
101/111.A16	[7]	11
	[7-1]	12

Checking the number of the refrigerant circuit controller: See chapter "System information" on page 183.

Temperature sensors

Viessmann NTC 10 k Ω (blue marking)

$\vartheta / ^\circ\text{C}$	R / k Ω	$\vartheta / ^\circ\text{C}$	R / k Ω	$\vartheta / ^\circ\text{C}$	R / k Ω	$\vartheta / ^\circ\text{C}$	R / k Ω	$\vartheta / ^\circ\text{C}$	R / k Ω	$\vartheta / ^\circ\text{C}$	R / k Ω
-40	336.500	-8	49.647	24	10.449	56	2.878	88	0.976	120	0.389
-39	314.870	-7	47.055	25	10.000	57	2.774	89	0.946	121	0.379
-38	294.780	-6	44.614	26	9.572	58	2.675	90	0.918	122	0.369
-37	276.100	-5	42.315	27	9.165	59	2.579	91	0.890	123	0.360
-36	258.740	-4	40.149	28	8.777	60	2.488	92	0.863	124	0.351
-35	242.590	-3	38.107	29	8.408	61	2.400	93	0.838	125	0.342
-34	227.550	-2	36.181	30	8.057	62	2.316	94	0.813	126	0.333
-33	213.550	-1	34.364	31	7.722	63	2.235	95	0.789	127	0.325
-32	200.510	0	32.650	32	7.402	64	2.158	96	0.765	128	0.317
-31	188.340	1	31.027	33	7.098	65	2.083	97	0.743	129	0.309
-30	177.000	2	29.495	34	6.808	66	2.011	98	0.721	130	0.301
-29	166.350	3	28.048	35	6.531	67	1.943	99	0.700	131	0.293
-28	156.410	4	26.680	36	6.267	68	1.877	100	0.680	132	0.286
-27	147.140	5	25.388	37	6.016	69	1.813	101	0.661	133	0.279
-26	138.470	6	24.165	38	5.775	70	1.752	102	0.642	134	0.272
-25	130.370	7	23.009	39	5.546	71	1.694	103	0.623	135	0.265
-24	122.800	8	21.916	40	5.327	72	1.637	104	0.606	136	0.259
-23	115.720	9	20.880	41	5.117	73	1.583	105	0.589	137	0.253
-22	109.090	10	19.900	42	4.917	74	1.531	106	0.572	138	0.247
-21	102.880	11	18.969	43	4.726	75	1.481	107	0.556	139	0.241
-20	97.070	12	18.087	44	4.543	76	1.433	108	0.541	140	0.235
-19	91.600	13	17.251	45	4.369	77	1.387	109	0.526	141	0.229
-18	86.474	14	16.459	46	4.202	78	1.342	110	0.511	142	0.224
-17	81.668	15	15.708	47	4.042	79	1.299	111	0.497	143	0.219
-16	77.160	16	14.995	48	3.889	80	1.258	112	0.484	144	0.213
-15	72.929	17	14.319	49	3.743	81	1.218	113	0.471	145	0.208
-14	68.958	18	13.678	50	3.603	82	1.180	114	0.458	146	0.204
-13	65.227	19	13.069	51	3.469	83	1.143	115	0.445	147	0.199
-12	61.722	20	12.490	52	3.340	84	1.107	116	0.434	148	0.194
-11	58.428	21	11.940	53	3.217	85	1.072	117	0.422	149	0.190
-10	55.330	22	11.418	54	3.099	86	1.039	118	0.411	150	0.185
-9	52.402	23	10.921	55	2.986	87	1.007	119	0.400		

Temperature sensors (cont.)

Viessmann NTC 20 k Ω (orange marking)

ϑ / °C	R / k Ω	ϑ / °C	R / k Ω	ϑ / °C	R / k Ω	ϑ / °C	R / k Ω	ϑ / °C	R / k Ω	ϑ / °C	R / k Ω
-40	702.156	10	40.034	60	4.943	110	1.009	165	0.259	215	0.097
-35	503.154	15	31.537	65	4.136	115	0.879	170	0.233	220	0.089
-30	364.902	20	25.027	70	3.478	120	0.768	175	0.209	225	0.081
-25	257.655	25	20.000	75	2.937	125	0.673	180	0.189	230	0.075
-20	198.442	30	16.090	80	2.492	130	0.592	185	0.171	235	0.069
-15	148.362	35	13.028	85	2.123	135	0.522	190	0.154	240	0.063
-10	112.403	40	10.613	90	1.816	140	0.461	195	0.140	245	0.058
-5	85.788	45	8.696	95	1.559	145	0.409	200	0.127	250	0.054
0	66.048	50	7.166	100	1.34	150	0.364	205	0.116	255	0.050
5	51.214	55	5.936	105	1.16	160	0.289	210	0.106	260	0.046

Temperature sensors (cont.)

Viessmann Pt500A (green marking)

$\vartheta / ^\circ\text{C}$	R / Ω	$\vartheta / ^\circ\text{C}$	R / Ω	$\vartheta / ^\circ\text{C}$	R / Ω	$\vartheta / ^\circ\text{C}$	R / Ω	$\vartheta / ^\circ\text{C}$	R / Ω	$\vartheta / ^\circ\text{C}$	R / Ω
-30	441.1	1	502.0	32	562.3	63	623.9	94	681.2	125	739.8
-29	443.1	2	503.9	33	564.2	64	622.0	95	683.1	126	741.7
-28	445.1	3	505.9	34	566.1	65	625.8	96	685.0	127	743.5
-27	447.0	4	507.8	35	568.1	66	627.7	97	686.9	128	745.4
-26	449.0	5	509.8	36	570.0	67	629.7	98	688.8	129	747.3
-25	451.0	6	511.7	37	571.9	68	631.6	99	690.7	130	749.2
-24	453.0	7	513.7	38	573.9	69	633.5	100	692.6	131	751.1
-23	454.9	8	515.6	39	575.8	70	635.4	101	694.4	132	752.9
-22	456.9	9	517.6	40	577.7	71	637.3	102	696.3	133	754.8
-21	458.9	10	519.5	41	579.7	72	639.2	103	698.2	134	756.7
-20	460.8	11	521.5	42	581.6	73	641.1	104	700.1	135	758.6
-19	462.8	12	523.4	43	583.5	74	643.1	105	702.0	136	760.4
-18	464.8	13	525.4	44	585.4	75	645.0	106	703.9	137	762.3
-17	466.7	14	527.3	45	587.4	76	646.9	107	705.8	138	764.2
-16	468.7	15	529.3	46	589.3	77	648.8	108	707.7	139	766.1
-15	470.6	16	531.2	47	591.2	78	650.7	109	709.6	140	767.9
-14	472.6	17	533.2	48	593.2	79	652.6	110	711.5	141	769.8
-13	474.6	18	535.1	49	595.1	80	654.5	111	713.4	142	771.7
-12	476.5	19	537.0	50	597.0	81	656.4	112	715.3	143	773.6
-11	478.5	20	539.0	51	598.9	82	658.3	113	717.2	144	775.4
-10	480.5	21	540.9	52	600.9	83	660.2	114	719.0	145	777.3
-9	482.4	22	542.9	53	602.8	84	662.1	115	720.9	146	779.2
-8	484.4	23	544.8	54	604.7	85	664.0	116	722.8	147	781.0
-7	486.3	24	546.8	55	606.6	86	665.9	117	724.7	148	782.9
-6	488.3	25	548.7	56	608.6	87	667.9	118	726.6	149	784.8
-5	490.2	26	550.6	57	610.5	88	669.8	119	728.5	150	786.7
-4	492.2	27	552.6	58	612.4	89	671.7	120	730.4	151	788.5
-3	494.2	28	554.5	59	614.0	90	673.6	121	732.2	152	790.4
-2	496.1	29	556.5	60	616.2	91	675.5	122	734.1	153	792.3
-1	498.1	30	558.4	61	618.2	92	677.4	123	736.0	154	794.1
0	500.0	31	560.3	62	620.1	93	679.3	124	737.9	155	796.0

Temperature sensors (cont.)

Connection to EEV PCB [4-3] / [4-4] / [4-6] / [4-7]: NTC 10 k Ω (no marking)

ϑ / °C	R / k Ω	ϑ / °C	R / k Ω	ϑ / °C	R / k Ω	ϑ / °C	R / k Ω	ϑ / °C	R / k Ω	ϑ / °C	R / k Ω
-40	325.700	-8	49.530	24	10.450	56	2.874	88	0.975	120	0.391
-39	305.400	-7	46.960	25	10.000	57	2.770	89	0.946	121	0.381
-38	286.500	-6	44.540	26	9.572	58	2.671	90	0.917	122	0.371
-37	268.800	-5	42.250	27	9.164	59	2.576	91	0.889	123	0.362
-36	252.300	-4	40.100	28	8.776	60	2.484	92	0.863	124	0.352
-35	236.900	-3	38.070	29	8.406	61	2.397	93	0.837	125	0.343
-34	222.600	-2	36.150	30	8.054	62	2.313	94	0.812	126	0.335
-33	209.100	-1	34.340	31	7.719	63	2.232	95	0.788	127	0.326
-32	196.600	0	32.630	32	7.399	64	2.155	96	0.765	128	0.318
-31	184.900	1	31.020	33	7.095	65	2.080	97	0.743	129	0.310
-30	173.900	2	29.490	34	6.804	66	2.009	98	0.721	130	0.302
-29	163.700	3	28.050	35	6.527	67	1.940	99	0.700	131	0.295
-28	154.100	4	26.680	36	6.263	68	1.874	100	0.680	132	0.288
-27	145.100	5	25.390	37	6.011	69	1.811	101	0.661	133	0.281
-26	136.700	6	24.170	38	5.770	70	1.750	102	0.642	134	0.274
-25	128.800	7	23.020	39	5.541	71	1.692	103	0.624	135	0.267
-24	121.400	8	21.920	40	5.321	72	1.636	104	0.606	136	0.261
-23	114.500	9	20.890	41	5.112	73	1.581	105	0.589	137	0.254
-22	108.000	10	19.910	42	4.912	74	1.529	106	0.573	138	0.248
-21	102.000	11	18.980	43	4.720	75	1.479	107	0.557	139	0.242
-20	96.260	12	18.100	44	4.538	76	1.431	108	0.541	140	0.237
-19	90.910	13	17.260	45	4.363	77	1.385	109	0.527	141	0.231
-18	85.880	14	16.470	46	4.196	78	1.340	110	0.512	142	0.226
-17	81.160	15	15.720	47	4.036	79	1.297	111	0.498	143	0.220
-16	76.720	16	15.000	48	3.884	80	1.256	112	0.485	144	0.215
-15	72.560	17	14.330	49	3.737	81	1.216	113	0.472	145	0.210
-14	68.640	18	13.690	50	3.597	82	1.178	114	0.459	146	0.206
-13	64.950	19	13.080	51	3.463	83	1.141	115	0.447	147	0.201
-12	61.480	20	12.500	52	3.335	84	1.105	116	0.435	148	0.196
-11	58.220	21	11.940	53	3.212	85	1.071	117	0.423	149	0.192
-10	55.150	22	11.420	54	3.095	86	1.038	118	0.412	150	0.187
-9	52.250	23	10.920	55	2.982	87	1.006	119	0.401		

Temperature sensors (cont.)

Connection to EEV PCB [6]: NTC 10 k Ω (no marking)

$\vartheta / ^\circ\text{C}$	R / k Ω	$\vartheta / ^\circ\text{C}$	R / k Ω	$\vartheta / ^\circ\text{C}$	R / k Ω	$\vartheta / ^\circ\text{C}$	R / k Ω	$\vartheta / ^\circ\text{C}$	R / k Ω	$\vartheta / ^\circ\text{C}$	R / k Ω
-40	188.50	-14	50.98	12	16.56	38	6.25	64	2.67	90	1.27
-39	178.50	-13	48.68	13	15.90	39	6.03	65	2.59	91	1.23
-38	169.00	-12	46.50	14	15.28	40	5.83	66	2.51	92	1.20
-37	160.20	-11	44.43	15	14.69	41	5.63	67	2.44	93	1.17
-36	151.90	-10	42.47	16	14.12	42	5.44	68	2.36	94	1.14
-35	144.10	-9	40.57	17	13.58	43	5.26	69	2.30	95	1.11
-34	136.70	-8	38.77	18	13.06	44	5.08	70	2.23	96	1.08
-33	139.80	-7	37.06	19	12.56	45	4.91	71	2.16	97	1.05
-32	123.30	-6	35.44	20	12.09	46	4.75	72	2.10	98	1.02
-31	117.10	-5	33.90	21	11.63	47	4.59	73	2.04	99	1.00
-30	111.30	-4	32.44	22	11.20	48	4.44	74	1.98	100	0.97
-29	105.70	-3	31.05	23	10.78	49	4.30	75	1.92	101	0.95
-28	100.50	-2	29.73	24	10.38	50	4.16	78	1.87	102	0.92
-27	95.52	-1	28.48	25	10.00	51	4.03	77	1.82	103	0.90
-26	90.84	0	27.28	26	9.63	52	3.90	76	1.77	104	0.88
-25	86.43	1	26.13	27	9.28	53	3.77	79	1.72	105	0.86
-24	82.26	2	25.03	28	8.94	54	3.65	80	1.67	106	0.84
-23	78.33	3	23.99	29	8.62	55	3.54	81	1.62	107	0.82
-22	74.61	4	23.00	30	8.31	56	3.43	82	1.58	108	0.80
-21	71.10	5	22.05	31	8.01	57	3.32	83	1.53	109	0.78
-20	67.77	6	21.15	32	7.73	58	3.22	84	1.49	110	0.76
-19	64.57	7	20.30	33	7.45	59	3.12	85	1.49		
-18	61.54	8	19.48	34	7.19	60	3.02	86	1.45		
-17	58.68	9	18.70	35	6.94	61	2.93	87	1.37		
-16	55.97	10	17.96	36	6.70	62	2.84	88	1.34		
-15	53.41	11	17.24	37	6.47	63	2.75	89	1.30		

Temperature sensors (cont.)

Connection to main PCB [7] / [7-1]: NTC 15 k Ω (no marking)

ϑ / °C	R / k Ω	ϑ / °C	R / k Ω	ϑ / °C	R / k Ω	ϑ / °C	R / k Ω	ϑ / °C	R / k Ω	ϑ / °C	R / k Ω
-20	144.000	5	38.150	30	12.070	56	4.294	81	1.811	106	0.848
-19	138.100	6	36.320	31	11.570	57	4.139	82	1.754	107	0.825
-18	128.600	7	34.580	32	11.090	58	3.990	83	1.699	108	0.802
-17	121.600	8	32.940	33	10.630	59	3.848	84	1.645	109	0.779
-16	115.000	9	31.380	34	10.200	60	3.711	85	1.594	110	0.758
-15	108.700	10	29.900	35	9.779	61	3.579	86	1.544	111	0.737
-14	102.900	11	28.510	36	9.382	62	3.454	87	1.497	112	0.717
-13	97.400	12	27.180	37	9.003	63	3.333	88	1.451	113	0.697
-12	92.220	13	25.920	38	8.642	64	3.217	89	1.408	114	0.678
-11	87.350	14	24.730	39	8.297	65	3.105	90	1.363	115	0.660
-10	82.750	15	23.600	41	7.653	66	2.998	91	1.322	116	0.642
-9	78.430	16	22.530	42	7.352	67	2.898	92	1.282	117	0.625
-8	74.350	17	21.510	43	7.065	68	2.797	93	1.244	118	0.608
-7	70.500	18	20.540	44	6.791	69	2.702	94	1.207	119	0.592
-6	66.880	19	19.630	45	6.529	70	2.611	95	1.171	120	0.577
-5	63.460	20	18.750	46	6.278	71	2.523	96	1.136	121	0.561
-4	60.230	21	17.930	47	6.038	72	2.439	97	1.103	122	0.547
-3	57.180	22	17.140	48	5.809	73	2.358	98	1.071	123	0.532
-2	54.310	23	16.390	49	5.589	74	2.280	99	1.039	124	0.519
-1	51.590	24	15.680	50	5.379	75	2.205	100	1.009	125	0.505
0	49.020	25	15.000	51	5.179	76	2.133	101	0.980	126	0.492
1	46.800	26	14.360	52	4.986	77	2.064	102	0.952	127	0.480
2	44.310	27	13.740	53	4.802	78	1.997	103	0.925	128	0.467
3	42.140	28	13.160	54	4.625	79	1.933	104	0.898	129	0.456
4	40.090	29	12.600	55	4.456	80	1.871	105	0.873	130	0.444

Temperature sensors (cont.)

Connection to main PCB [7] / [7-1]: NTC 20 k Ω (no marking)

ϑ / °C	R / k Ω	ϑ / °C	R / k Ω	ϑ / °C	R / k Ω	ϑ / °C	R / k Ω	ϑ / °C	R / k Ω	ϑ / °C	R / k Ω
-25	265.500	1	62.130	27	18.320	53	6.403	79	2.577	105	1.164
-24	249.900	2	59.080	28	17.550	54	6.167	80	2.495	106	1.131
-23	235.300	3	56.190	29	16.800	55	5.942	81	2.415	107	1.099
-22	221.600	4	53.460	30	16.100	56	5.726	82	2.339	108	1.069
-21	208.900	5	50.870	31	15.430	57	5.519	83	2.265	109	1.039
-20	196.900	6	48.420	32	14.790	58	5.320	84	2.194	110	1.010
-19	181.400	7	46.110	33	14.180	59	5.130	85	2.125	111	0.983
-18	171.400	8	43.920	34	13.590	60	4.948	86	2.059	112	0.956
-17	162.100	9	41.840	35	13.040	61	4.773	87	1.996	113	0.930
-16	153.300	10	39.870	36	12.510	62	4.605	88	1.934	114	0.904
-15	145.000	11	38.010	37	12.000	63	4.443	89	1.875	115	0.880
-14	137.200	12	36.240	38	11.520	64	4.289	90	1.818	116	0.856
-13	129.900	13	34.570	39	11.060	65	4.140	91	1.763	117	0.833
-12	123.000	14	32.980	40	10.620	66	3.998	92	1.710	118	0.811
-11	116.500	15	31.470	41	10.200	67	3.861	93	1.658	119	0.790
-10	110.300	16	30.040	42	9.803	68	3.729	94	1.609	120	0.769
-9	104.600	17	28.680	43	9.420	69	3.603	95	1.561	121	0.749
-8	99.130	18	27.390	44	9.054	70	3.481	96	1.515	122	0.729
-7	94.000	19	26.170	45	8.705	71	3.364	97	1.470	123	0.710
-6	89.170	20	25.010	46	8.370	72	3.252	98	1.427	124	0.692
-5	84.610	21	23.900	47	8.051	73	3.144	99	1.386	125	0.674
-4	80.310	22	22.850	48	7.745	74	3.040	100	1.346	126	0.656
-3	76.240	23	21.850	49	7.453	75	2.940	101	1.307	127	0.640
-2	72.410	24	20.900	50	7.173	76	2.844	102	1.269	128	0.623
-1	68.790	25	20.000	51	6.905	77	2.752	103	1.233	129	0.607
0	65.370	26	19.140	52	6.648	78	2.663	104	1.198	130	0.592

Temperature sensors (cont.)

Connection to main PCB [7] / [7-1]: NTC 50 k Ω (no marking)

ϑ / °C	R / k Ω	ϑ / °C	R / k Ω	ϑ / °C	R / k Ω	ϑ / °C	R / k Ω	ϑ / °C	R / k Ω	ϑ / °C	R / k Ω
-25	660.930	1	153.000	27	45.074	53	15.753	79	6.332	105	2.872
-24	620.940	2	145.420	28	43.163	54	15.173	80	6.129	106	2.792
-23	583.720	3	138.260	29	41.313	55	14.618	81	5.934	107	2.715
-22	549.040	4	131.500	30	39.610	56	14.085	82	5.746	108	2.640
-21	516.710	5	126.170	31	37.958	57	13.575	83	5.565	109	2.568
-20	486.550	6	119.080	32	36.384	58	13.086	84	5.390	110	2.498
-19	458.400	7	113.370	33	34.453	59	12.617	85	5.222	111	2.431
-18	432.100	8	107.960	34	33.453	60	12.368	86	5.061	112	2.365
-17	407.510	9	102.850	35	32.088	61	11.736	87	4.904	113	2.302
-16	384.510	10	98.006	36	30.787	62	11.322	88	4.754	114	2.241
-15	362.990	11	93.420	37	29.544	63	10.925	89	4.609	115	2.182
-14	342.830	12	89.075	38	28.359	64	10.544	90	4.469	116	2.124
-13	323.940	13	84.956	39	27.227	65	10.178	91	4.335	117	2.069
-12	306.230	14	81.052	40	26.147	66	9.827	92	4.204	118	2.015
-11	289.610	15	77.349	41	25.114	67	9.490	93	4.079	119	1.963
-10	274.020	16	73.896	42	24.128	68	9.166	94	3.958	120	1.912
-9	259.370	17	70.503	43	23.186	69	8.954	95	3.841	121	1.865
-8	245.610	18	67.338	44	22.286	70	8.555	96	3.728	122	1.816
-7	232.670	19	64.330	45	21.425	71	8.268	97	3.619	123	1.770
-6	220.500	20	61.478	46	20.601	72	7.991	98	3.514	124	1.725
-5	209.050	21	58.766	47	19.814	73	7.726	99	3.413	125	1.682
-4	198.270	22	56.189	48	19.061	74	7.470	100	3.315	126	1.640
-3	188.120	23	53.738	49	18.340	75	7.225	101	3.220	127	1.600
-2	178.650	24	51.408	50	17.651	76	6.988	102	3.129	128	1.560
-1	169.680	25	49.191	51	16.990	77	6.761	103	3.040	129	1.522
0	161.020	26	47.082	52	16.358	78	6.542	104	2.955	130	1.485

Pressure sensors

Connection to EEV PCB [4] / [4-3] / [4-4] / [4-6] / [4-7]

Pressure sensors for soldering or with threaded fittings are used.

Sensor	Refrigerant	
	R407C/R134a	R410A
Low pressure sensor	Up to 7 bar (0.7 MPa)	Up to 18 bar (1.8 MPa)
High pressure sensor	Up to 30 bar (3 MPa)	Up to 50 bar (5 MPa)

Pressure sensors (cont.)

Curves

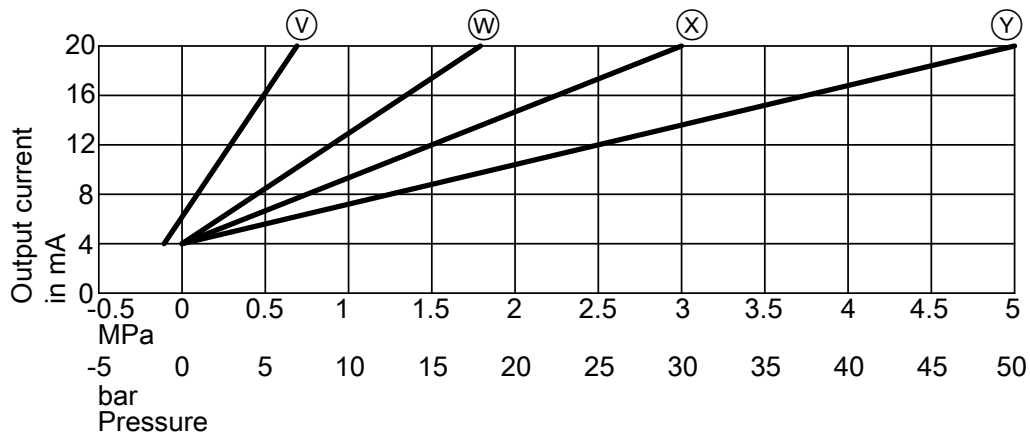

Fig. 83

- Ⓧ Up to 7 bar (0.7 MPa)
- Ⓦ Up to 18 bar (1.8 MPa)

- Ⓧ Up to 30 bar (3 MPa)
- Ⓨ Up to 50 bar (5 MPa)

Connection to EEV PCB [2] / [6] / [7] / [7-1]

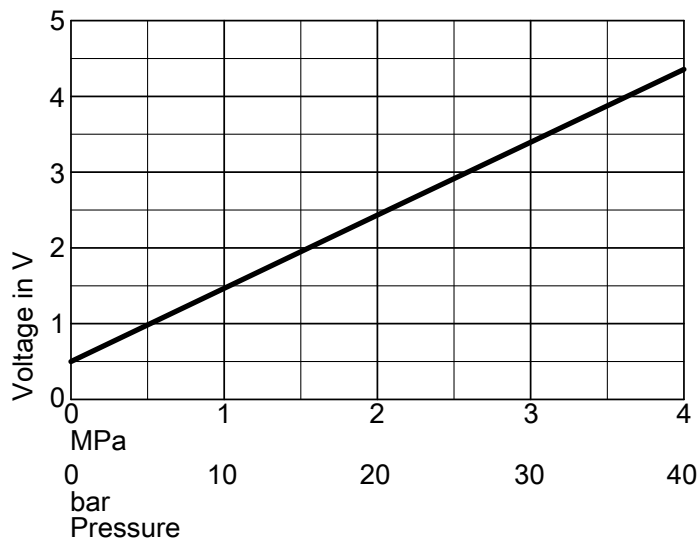

Fig. 84

Declarations of conformity for heat pumps



Installation and service instructions of the relevant heat pump

Keyword index

2		Average ground temperature.....	206
2-stage refrigerant circuit.....	27, 138	Averaging interval.....	197
– Compressor, switching off.....	28	B	
– Compressor demand.....	28	Background ventilation.....	260, 261, 262
– Required parameter settings.....	27	Bathroom switch.....	59, 256
– Switching on the compressor.....	28	Bit field.....	194
3		Blocking bypass damper.....	254
3-way diverter damper.....	67, 68, 259	Blocking time, defrost.....	120
4		Blocking time, DHW heating.....	221
4-way diverter valve.....	304, 308, 309, 310	Boiler water temperature sensor.....	301
A		Booster heater	
Absorber circuit.....	27	– Operating mode.....	221
Absorber circuit pump.....	113	Booster heaters.....	37
Absorberkreis.....	207	Booster heaters for central heating	
Absorber temperature.....	113	– For central heating.....	54
Acknowledging messages.....	74	Brief scan.....	182
Active cooling.....	246	Buffer cylinder.....	43
– Enable.....	249	– Connections for heat pump cascade.....	45
– Start threshold.....	229	– Frost protection.....	47
Actual extract air temperature.....	130	– Heating with booster heaters.....	46
Actual supply air temperature.....	130	– Heating with heat pump.....	45, 46
Actuator test.....	185	– Max. temperature.....	237
Additional code.....	75	– Operating mode fixed value.....	238
Advance runtime		– Operating status.....	45, 47
– Fan.....	120	– Operating status fixed value.....	236
– Primary pump.....	120	– Set temperature.....	236
Air/water heat pumps		– Stop hysteresis.....	238
– Indoor installation.....	17	– Stop optimisation.....	237
– Monoblock version.....	17, 20	– Switching heat-up off.....	45
– Outdoor installation.....	17	– Switching heat-up on.....	45
– Split version.....	17	– Temperature limit fixed value.....	237
Air discharge temperature.....	139, 141	– With utilisation of power generated on site.....	70
Air discharge temperature sensor.....	304	Buffer cylinder (parameter group).....	236
Air flow rate		Buffer cylinder heating with utilisation of power gener- ated on site.....	71, 72
– Background ventilation.....	65	Buffer cylinders	
– Balancing of pressure differentials.....	59, 66	– Overview.....	44
– Economy mode.....	58, 65	Buffer outlet temperature sensor.....	30, 301
– Exhaust air.....	118, 129	Buffer temperature.....	116
– Extract air.....	118	Buffer temperature sensor.....	44, 45, 46, 301, 302
– Holiday program.....	58, 65	Bypass.....	59, 60, 66, 132, 254
– Intensive ventilation.....	58, 65	– Function.....	263
– Nominal ventilation.....	58, 65	Bypass function.....	263
– Reduced ventilation.....	58, 65	Bypass temperature, set value.....	260
– Standard operation.....	58, 65	C	
– Standby mode.....	58, 65	Calling up messages.....	74
– Supply air.....	118, 130	Calling up temperatures.....	103
Air humidity.....	64, 68, 136	Carbon dioxide concentration.....	64, 68, 129, 133, 253
Air intake temperature		Cascade.....	29, 199, 274
– Evaporator.....	140	– Number of lag heat pumps.....	205
Air intake temperature, evaporator.....	142, 145	Cascade control.....	199
Air intake temperature sensor.....	304, 307, 312	Central cooling	
AM1 extension.....	26, 200	– Deactivating.....	53
Analogue signal input, ventilation unit.....	265, 266	– Starting.....	52
Appliances types.....	15, 16	– With utilisation of power generated on site.....	70, 72
Application limits, compressor.....	146, 147		
Automatic time changeover.....	273		

Keyword index (cont.)

- Central heating
 - Max. duration..... 121
 - Starting..... 52
 - Switching off..... 52
 - Via ventilation unit..... 54
 - With external heat generator..... 37, 38
 - With external heat source..... 213
 - With instantaneous heating water heater..... 37, 40
 - With utilisation of power generated on site..... 70, 71
- Central humidity sensor..... 259, 264
- Changeover, operating status..... 201
- Changing operating status..... 125
- Circulation pump for swimming pool heating..... 57
- CO₂-/humidity sensor..... 265, 266
- CO₂ sensor..... 251
- Coding card..... 16, 184
 - Slot..... 300, 302
- Coding level 1..... 24, 193
- Coefficients
 - Temperature sensor, type NTC 10 kΩ... 314, 317, 318
 - Temperature sensor, type NTC 15 kΩ..... 319
 - Temperature sensor, type NTC 20 kΩ..... 315, 320
 - Temperature sensor, type NTC 50 kΩ..... 321
 - Temperature sensor, type Pt500A..... 316
- Collector circuit pump..... 113
- Collector temperature..... 113
- Combi cylinder..... 220
- Common flow temperature sensor..... 204
- Communication (parameter group)..... 274
- Communication interface..... 203
- Communication via LON
 - Fault manager..... 274
 - Receive interval for data..... 275
 - Subscriber number..... 274
 - System number..... 274
- Compressor
 - Enable..... 209
 - Enabling..... 210
 - Output..... 210
 - Parameter group..... 209
- Compressor output..... 140
 - At max. outside temperature..... 230
 - In starting phase..... 229
- Compressor path..... 147
- Compressor pause..... 120
- Compressor runtime..... 136, 147
- Compressor speed..... 138, 142, 145
- Compressor starting phase..... 229
- Compressor switching..... 309
- Compressor travel..... 146
- Concentration, carbon dioxide..... 64, 68
- Condensate pan..... 307
- Condensing pressure..... 142, 144
- Condensing temperature.....
 - 126, 139, 141, 142, 143, 144, 146, 148
- Configuration fault..... 75
- Connecting cable, EEV..... 174
- Connections, DHW heating..... 287
- Contact humidistat..... 50, 244, 301, 303
- Control (parameter group)..... 277
- Control circuit
 - Consumers..... 127
 - Demand manager..... 127
 - Heat sources..... 127
 - Production manager..... 127
- Control high pressure.....
 - 150, 154, 160, 166, 173, 176, 220
- Controller and sensor PCB..... 300, 302
- Controller PCB [6]..... 310
- Controls, locking out..... 277
- Controls lock-out..... 277
- Control strategy, primary source..... 234
- Control unit settings..... 193, 196
- Control voltage
 - Exhaust air fan..... 132
 - Matching..... 255, 257, 258
 - Supply air fan..... 132
- Coolant buffer temperature..... 118
- Cooling
 - Hysteresis room temperature..... 247
 - Parameter group..... 246
 - Selecting a cooling circuit..... 246
 - Via geothermal heat exchanger..... 67
- Cooling circuit..... 49
 - Cooling curve..... 245, 248
 - Enable flow temperature sensor..... 248
 - Room temperature control..... 247
 - Selecting..... 246
- Cooling functions..... 55, 246
- Cooling limit..... 51, 198
- Correction factor, air flow rate..... 266
- Countercurrent heat exchanger..... 59, 255
- Cross connect PCB..... 289
- Cursor key..... 25
- Cycle rate, heating circuit pump..... 230
- Cylinder loading pump..... 221
- Cylinder temperature
 - Bottom..... 116
 - Top..... 116
- Cylinder temperature sensor
 - Bottom..... 301
 - Top..... 301, 302
- D**
- Declarations of conformity..... 323
- Defrost blocking time..... 120
- Defrost end..... 209
- Defrost function..... 61, 131, 132
- Defrosting
 - Blocking time..... 120
 - Remaining time..... 120
- Defrost integral..... 123
- Defrost temperature sensor..... 176, 312
- Degree of ice formation..... 61
- Demand..... 126
 - External heat generator..... 114, 116
 - Swimming pool heating..... 114, 116

DHW	
– Cylinder temperature sensor, bottom.....	219
– Hysteresis.....	217
– Max. temperature.....	216
– Min. temperature.....	216
– Parameter group.....	216
– Set temperature 2.....	218
– Set value.....	216
– Start optimisation.....	218
– Stop optimisation.....	218
– Temperature sensor 2.....	219
DHW cylinder	
– Frost protection.....	43
– Max. temperature.....	216
– Min. temperature.....	216
DHW heating.....	40
– Blocking time.....	41, 221
– Cylinder loading pump.....	221
– Cylinder temperature sensor, bottom.....	219
– Max. duration.....	121
– Max. interruption.....	219
– Max. pause duration.....	41, 222
– Max. runtime.....	219
– Priority.....	220
– Set temperature 2.....	218
– Start optimisation.....	218
– Stop hysteresis, instantaneous heating water heater.....	220
– Stop optimisation.....	218
– Switching on and off.....	41
– Temperature rise per hour.....	218
– Temperature sensor 2.....	219
– With combi cylinder.....	220
– With control high pressure.....	220
– With external heat generator.....	213
– With utilisation of power generated on site.....	69, 70
DHW reheating	
– Booster heaters.....	42
– Enabling.....	42
– External heat source.....	219
– Immersion heater.....	219
– Switching off.....	42
– Switching on.....	42
– With external heat generator.....	39
Diagnosis.....	103
– Brief scan.....	182
– Compressor path.....	147
– Compressor runtime.....	136
– Compressor travel.....	146
– Energy statement.....	178
– Heat pump.....	136
– Photovoltaics.....	180
– Refrigerant circuit.....	137
– Refrigerant circuit controller.....	137, 139, 141, 143, 145, 146, 147, 148, 153, 159, 164, 172, 175
– Software version.....	183
– System.....	120
– System overview.....	110
– Ventilation.....	128, 130, 132, 135
Differential air flow rate.....	59
Differential pressure switch.....	132
Disbalance.....	59, 263, 264
Diverter valve	
– Heating/DHW heating.....	229
Drying buildings.....	227
Dual mode operation.....	38, 214
Dual mode temperature, ice store.....	207
Duration, intensive mode.....	254
Duration, intensive operation.....	58, 65
Duration of external changeover.....	201
E	
EA1 extension.....	56, 57, 200
Earth conductor.....	279
Economy mode.....	58, 65
Economy tariff.....	34
EEV PCB [2].....	304, 305
EEV PCB [4].....	306
EEV PCB [4-3] / [4-4].....	307
EEV PCB [4-6] / [4-7].....	308
EEV PCB [6].....	310
Effect of external blocking.....	202, 203
Einschalthysterese Solar-Luftabsorber.....	205
Eisspeicher.....	207
– Sommerbetrieb.....	206
Electrical connections, information.....	279
Electric heater (parameter group).....	224
Electric preheating coil.....	62, 63, 67, 259
Electronic expansion valve.....	311
Electronic expansion valve opening.....	139, 141, 143, 144, 146
Enable	
– Active cooling mode.....	249
– Buffer cylinder for utilisation of power generated on site.....	269
– Central cooling for utilisation of power generated on site.....	269
– Central heating for on-site power consumption.....	269
– CO2 sensor.....	251
– Compressor stage for central cooling.....	209
– Compressor stage for central heating.....	209
– Compressor stage for DHW heating.....	209
– DHW heating for on-site power consumption.....	268
– Electric preheating coil.....	250
– Heating water/coolant buffer cylinder for utilisation of power generated on site.....	269
– Humidity sensor.....	251
– Hydraulic reheating coil.....	250
– Set DHW temperature 2.....	268
Enable compressor	
– For central heating.....	210
– For DHW heating.....	210
– For room cooling.....	210
– For swimming pool heating.....	210

Keyword index (cont.)

- Enabling
 - Immersion heater..... 220, 224
 - Instantaneous heating water heater..... 220, 224, 225
 - LON communication module..... 274
 - Reheating coil..... 64
 - Smart Grid..... 271
 - Utilisation of power generated on site..... 267
- Energy meter..... 69, 267
- Energy statement..... 149, 176, 178
 - DHW..... 179
 - Heating..... 179
 - Utilisation of power generated on site..... 179
- Enthalpy heat exchanger..... 59, 255
- Error history..... 74
- Evaporation pressure..... 142, 144
- Evaporation temperature.....
 - 139, 141, 142, 143, 144, 146, 148
- Evaporator air intake temperature..... 138
- Evaporator temperature..... 112
- Evaporator temperature for defrost end..... 209
- Evaporator temperature sensor..... 149, 307
- Exhaust air fan..... 128
- Exhaust air temperature..... 63, 118, 129
- Exhaust air temperature sensor..... 133, 134
- Expansion PCB..... 284
- Extended menu..... 25
- External blocking..... 32, 33, 118, 125, 202, 203
- External demand..... 32, 33, 118, 125, 202, 203, 204
 - Heating circuits..... 32
 - Heat pump..... 32
 - Set flow temperature..... 228
- External heat generator..... 38, 42, 54
 - Dual mode temperature..... 211
 - Min. runtime..... 212
 - Operating mode..... 221
 - Parameter group..... 211
- External heat source
 - Central heating..... 213
 - DHW heating..... 213
 - DHW reheating..... 39
 - Enabling..... 211
 - Excess, flow temperature..... 213
 - Min. temperature..... 214, 215
 - Priority..... 211
 - Run-on time..... 213
 - Start delay..... 212
 - Start threshold..... 212
 - Temperature mixer OPEN..... 212
- External hook-up for heating/cooling circuits..... 33
- Extract air temperature..... 60, 61, 66, 118, 252, 260
 - Sensor matching..... 258
- Extract air temperature sensor..... 133, 134, 136

- F**
- Fan, inverter..... 305
- Fan blocking time..... 253
- Fan ribbon heater..... 310
- Fan speed..... 138, 140, 142, 144, 145
- Fan start time..... 62
- Fault..... 74
 - Fault code..... 75
 - Refrigerant circuit controller [2]..... 148
 - Refrigerant circuit controller [4]..... 153
 - Refrigerant circuit controller [4-3] / [4-4]..... 159
 - Refrigerant circuit controller [4-6] / [4-7]..... 165
 - Refrigerant circuit controller [6]..... 172
 - Refrigerant circuit controller [7] / [7-1]..... 175
 - Ventilation..... 132, 135
 - Fault display, calling up..... 74
 - Fault list..... 75
 - Refrigerant circuit controller [2]..... 148
 - Refrigerant circuit controller [4]..... 153
 - Refrigerant circuit controller [4-3] / [4-4]..... 159
 - Refrigerant circuit controller [4-6] / [4-7]..... 165
 - Refrigerant circuit controller [6]..... 172
 - Refrigerant circuit controller [7] / [7-1]..... 175
 - Ventilation..... 132, 135
 - Fault manager..... 274
 - Fault memory..... 74
 - Fault messages..... 75
 - Refrigerant circuit controller [2]..... 148
 - Refrigerant circuit controller [4]..... 153
 - Refrigerant circuit controller [4-3] / [4-4]..... 159
 - Refrigerant circuit controller [4-6] / [4-7]..... 165
 - Refrigerant circuit controller [6]..... 172
 - Refrigerant circuit controller [7] / [7-1]..... 175
 - Ventilation..... 132, 135
 - Fault messages, calling up..... 74
 - Filter, checking..... 132
 - Filter circuit pump..... 56
 - Flow rate
 - Background ventilation..... 65
 - Correction factor..... 266
 - Economy mode..... 58, 65
 - Exhaust air..... 118, 129
 - Extract air..... 118
 - Holiday program..... 58, 65
 - Intensive ventilation..... 58, 65
 - Nominal ventilation..... 58, 65
 - Reduced ventilation..... 58, 65
 - Standard operation..... 58, 65
 - Standby mode..... 58, 65
 - Supply air..... 118, 130
 - Flow rate adjustment..... 253
 - Flow rate difference..... 263
 - Flow switch..... 126, 310
 - Flow temperature
 - Cooling..... 118
 - Primary circuit..... 112, 144
 - Secondary circuit... 112, 119, 138, 140, 142, 144, 145
 - Separate cooling circuit..... 117
 - System..... 114

- Flow temperature sensor
- Cooling circuit.....50, 248, 301, 303
 - Heating circuit..... 49
 - Heating circuit with mixer..... 301, 303
 - Primary circuit..... 308, 309
 - Secondary circuit.....
161, 167, 301, 302, 307, 308, 309, 310
 - Swimming pool.....56, 301
 - System..... 50, 204, 301, 303
- Four-way diverter valve.....307, 312
- Frost protection..... 39, 77, 202, 203, 263
- Buffer cylinder..... 47
 - Comfort function.....62
 - DHW cylinder.....43
 - Restarting of fans..... 256, 257
 - Ventilation unit.....255
 - Ventilator..... 253
 - Vitivent 200-C..... 61
 - Vitivent 200-W/300-C/300-W..... 67
 - Vitivent 300-F.....63
 - With geothermal heat exchanger..... 67
 - Without preheating coil.....63, 67
 - With preheating coil.....63, 67
- Frost risk, condenser.....156, 162, 168, 174
- Function check..... 188
- Function description..... 26
- G**
- Geothermal collector.....26
- Geothermal heat exchanger.....67, 259
- Min. temperature.....265
- Geothermal probe..... 26
- H**
- Hardware index, refrigerant circuit controller..... 184
- Heat exchanger.....59, 65, 128, 252, 255
- Heating, condensate pan..... 307
- Heating/cooling circuit.....49
- Heating circuit..... 49
- Heating curve.....242
 - Max. flow temperature.....243
- Heating circuit/cooling circuit.....246
- Cooling limit.....51
 - Function description.....48
 - Heating limit..... 51
 - Minimum flow rate.....48
 - Operating status.....53
 - Remote control.....241
 - Room temperature-dependent control..... 51
 - Room temperature influence.....51
- Heating circuit/Cooling circuit
- Standard room temperature.....241
 - Weather-compensated control..... 50
- Heating circuit/cooling circuit (parameter group).....241
- Heating circuit for blocking bypass damper..... 254
- Heating circuit pump..... 50
- Heating limit..... 51, 197
- Heating water/coolant buffer cylinder.43, 48, 50, 56, 69
- Cooling activation.....46
 - Cooling deactivation.....46
 - Min. temperature.....239
 - Operating status fixed value.....238
 - Set temperature..... 238
 - Stop hysteresis.....238, 239
 - With utilisation of power generated on site..... 70
- Heating water buffer cylinder..... 48, 50, 55, 236
- Enabling..... 236
 - Start hysteresis..... 236
- Heat pump
- Calling up..... 31
 - Output..... 210
 - Shutting down..... 32
- Heat pump cascade..... 29, 30, 199, 274
- Buffer cylinder connections..... 45
 - Flow temperature control..... 30
 - Hydraulic connection versions..... 29
- Heat pump control unit LON integration.....30
- Heat recovery.....59, 65, 255
- Heat recovery level..... 118
- Heat sink, inverter..... 305
- Heat sources..... 127
- Help text..... 25
- High efficiency circulation pump.....232
- High limit safety cut-out, preheating coil..... 134
- High pressure fault..... 150, 154, 160, 166, 173, 176
- High pressure sensor.....
149, 159, 165, 172, 176, 304, 307, 308, 309, 310, 312
- High pressure switch.....312
- Holiday program, ventilation.....58, 65
- Holiday program effect..... 208
- Hot gas pressure..... 138, 140, 142, 144, 145
- Hot gas temperature..... 126, 138, 140, 142, 144, 145
- Hot gas temperature sensor.....
149, 154, 159, 160, 165, 172, 173, 176, 304, 307,
308, 309, 312
- Hours run..... 103
- Humidity..... 64, 68, 133, 136, 253
- Humidity control..... 59, 65
- Humidity sensor..... 251, 259, 264
- Hysteresis
- Solar air absorber.....205
- Hysteresis room temperature cooling circuit..... 247
- I**
- Ice formation..... 61, 62
- Ice store..... 26, 205
- Electrical devices..... 26
 - Summer mode.....26, 206, 207
- Ice store extension..... 26
- Icing up.....62, 131
- Immersion heater..... 42
- Enabling..... 219
- Information for service requests..... 184
- Input 0..10V.....203
- Installation kit with mixer..... 207
- Installation position, ventilation unit.....256

Keyword index (cont.)

- Instantaneous heating water heater..... 42, 54
 – DHW heating..... 40
 – Dual mode temperature..... 226
 – Enabling..... 224, 225
 – Function description..... 39
 – Max. output stage..... 225
 – Max. output stage at power-OFF..... 226
 – Operating mode..... 221
 – Start delay..... 225
 – Start threshold..... 229
 Integrals..... 121
 Intensive mode..... 252, 254, 261
 – Max. duration..... 256
 Internal hydraulics (parameter group)..... 227
 Interval for long term average outside temperature. 197
 Inverter..... 305
- K**
 Keys..... 25
 KM-BUS..... 300, 302
 KM-BUS subscribers..... 187
- L**
 Lag heat pump..... 29, 30, 274
 Lead heat pump..... 30
 Limit for status change..... 124
 Liquid gas temperature..... 139, 141, 146
 Liquid gas temperature sensor.....
 149, 154, 161, 165, 166, 301, 303, 304, 306, 308, 309
 Load classes..... 137
 Loading settings..... 192
 Locking out the controls..... 277
 Lock-out, controls..... 277
 Logbook..... 123
 LON
 – Addressing..... 274
 – Outside temperature 275
 – Receive interval for data..... 275
 – Receiving the time..... 275
 – Send outside temperature..... 275
 – Send time..... 276
 – Subscriber check..... 187
 – Subscriber number..... 274
 – System number..... 274
 LON cascade..... 29, 274
 LON communication module..... 30, 187
 – Enabling..... 274
 – Slot..... 300, 302
 Long term average of outside temperature..... 112
 LON manual..... 187
 LON module..... 30, 274
 LON subscriber..... 187
 Low loss header..... 47
 – Enabling..... 236
 – Function description..... 43
 Low pressure sensor.....
 149, 159, 166, 173, 304, 306, 307, 308, 309, 310, 311
- Low pressure switch..... 310, 312
 Luster terminals..... 292, 294
 – Vitocal 200-A..... 296
 – Vitocal 222-G/333-G..... 299
- M**
 Main PCB..... 280
 Main PCB [7] / [7-1]..... 312
 Matching control voltage..... 255, 257, 258
 Max. duration central heating..... 121
 Max. duration DHW heating..... 121
 Max. flow temperature, heating circuit..... 243
 Max. operating pressure, evaporator.....
 151, 155, 161, 167
 Mechanical ventilation..... 57, 250
 – Diagnosis..... 128, 130
 – Vitovent 200-C..... 58
 – Vitovent 200-W..... 65
 – Vitovent 300-C..... 65
 – Vitovent 300-F..... 58
 – Vitovent 300-W..... 65
 Message A9, C9..... 204
 Message connections..... 289, 299
 Message history..... 74
 – Refrigerant circuit controller [2]..... 148
 – Refrigerant circuit controller [4]..... 153
 – Refrigerant circuit controller [4-3] / [4-4]..... 159
 – Refrigerant circuit controller [4-6] / [4-7]..... 164
 – Refrigerant circuit controller [6]..... 172
 – Refrigerant circuit controller [7] / [7-1]..... 175
 – Ventilation..... 132, 135
 Message list..... 74
 Messages
 – Acknowledging..... 74
 – Calling up..... 74
 – Fault..... 74
 – Message history, calling up..... 74
 – Note..... 74
 – Overview..... 75
 – Recalling..... 74
 – Refrigerant circuit controller [2]..... 148
 – Refrigerant circuit controller [4]..... 153
 – Refrigerant circuit controller [4-3] / [4-4]..... 159
 – Refrigerant circuit controller [4-6] / [4-7]..... 165
 – Refrigerant circuit controller [6]..... 172
 – Refrigerant circuit controller [7] / [7-1]..... 175
 – Ventilation..... 132, 135
 – Warning..... 74
 Min. runtime compressor..... 120
 Min. set flow temperature cooling..... 246
 Min. supply air temperature for bypass..... 252
 Min. temperature, geothermal heat exchanger..... 265
 Mindesttemperatur Solar-Luftabsorber..... 206
 Minimum flow rate..... 48
 Mixer, external heat generator..... 212
 Mixer extension kit..... 49
 Mixer heating circuit..... 243
 Mixer motor..... 49
 Modbus..... 57, 184, 300, 301, 302, 304
 Modbus connecting cable..... 310, 311

Modbus distributor.....300, 302
 Modbus subscriber..... 187
 Monoblock version..... 17, 20

N

Natural cooling..... 246
 NC-Box.....303
 NC mixer..... 50
 Neutral conductor.....279
 Nominal ventilation.....252, 261, 262
 Note.....74

O

Offset.....186
 Oil sump heater.....312
 On-site energy consumption
 – Heating to set DHW temperature 2.....71
 On-site power consumption
 – Central heating.....269, 270
 – DHW heating.....268, 270
 – Heating water buffer cylinder.....270
 – Set DHW temperature 2.....268
 – Threshold for electrical power.....268
 Operating data call-up.....103
 Operating info.....25
 Operating mode
 – Booster heater.....221
 – External heat generator.....221
 – Instantaneous heating water heater.....221
 Operating point.....126
 Operating status.....125
 – Buffer cylinder.....45, 47
 – Changeover.....32, 33, 200
 – For external changeover.....201
 Operating status, ventilation
 – Intensive.....58, 65
 – Reduced.....58, 65
 – Standard.....58, 65
 Operating status changeover.....118
 Operating status ventilation.....58, 65
 Outdoor air temperature.....60, 61, 66, 128
 Outdoor air temperature sensor.....133, 134, 136
 – Sensor matching.....258
 Output
 – Cylinder loading pump.....116
 – Heat pump.....210
 – Preheating coil.....118
 – Primary pump.....112
 – Primary source.....210
 – Secondary pump.....112
 Output control strategy.....199
 Output curves.....182
 Output default.....122
 Output matching with utilisation of power generated on site.....70
 Output stage, instantaneous heating water heater....39
 Outside temperature
 – Long term average.....197
 – Send.....275
 – Source.....275

Outside temperature sensor.....301, 302
 Overview
 – Messages.....75
 – Refrigerant circuit controller.....24
 – Ventilation.....128

P

Parameter.....196
 Parameter code.....193, 194
 Parameter group.....194
 – Buffer cylinder.....236
 – Communication.....274
 – Compressor.....209
 – Control.....277
 – Cooling.....246
 – DHW.....216
 – Electric heater.....224
 – External heat generator.....211
 – Heating circuit/cooling circuit.....241
 – Internal hydraulics.....227
 – Photovoltaics.....267
 – Primary source.....234
 – Smart Grid.....271
 – Solar.....223
 – System definition.....196
 – Time.....273
 – Ventilation.....250
 Parameters
 – Resetting.....195
 – Setting.....193
 Parameters, setting.....194
 Party mode.....244
 Passive cooling.....60, 66, 132, 252
 Passive heating.....59, 132
 Passive house.....63
 Pause duration, DHW heating.....222
 PCB.....278
 – Controller and sensor PCB.....300, 302
 – Controller PCB [6].....310
 – Cross connect PCB.....289
 – EEV PCB [2].....304
 – EEV PCB [4].....306
 – EEV PCB [4-3] / [4-4].....307
 – EEV PCB [4-6] / [4-7].....308
 – EEV PCB [6].....310
 – Expansion PCB.....284
 – Luster terminals.....292, 294, 296, 299
 – Main PCB.....280
 – Main PCB [7] / [7-1].....312
 Photovoltaics.....69, 180, 267
 – Enabling utilisation of power generated on site.....70
 – Output matching with utilisation of power generated on site.....70
 PIN code.....188
 Power-OFF.....34, 36, 125, 271
 – Connection versions.....34
 Power-OFF signal.....35, 36
 Power supply utility.....34
 Preheating coil.....63, 67, 128
 – Enabling.....250

Keyword index (cont.)

- Pressure differential, supply/extract air flow rates 59, 66
 Pressure imbalance..... 263, 264
 Pressure sensor..... 321
 – Suction gas..... 154
 Pressure switch..... 96
 Primary circuit
 – Min. inlet temperature..... 235
 – Response delay..... 235
 Primary pump..... 308, 309
 – Manufacturer information..... 234
 Primary pump, switching state in cooling mode..... 198
 Primary source..... 26, 234
 – Geothermal collector..... 205
 – Geothermal probe..... 205
 – Ice store..... 205
 – Output..... 210
 – PWM signal..... 234
 – Solar air absorber..... 205
 Primary source (parameter group)..... 234
 Priority external demand..... 203
 Production manager..... 126, 127
 Programming unit..... 25, 102
 Proportion of external power..... 267
 Pump kick..... 54
 PV statistics..... 181
 PWM control
 – Primary source..... 234
 PWM signal..... 301, 302, 310
 PWM switching
 – Cylinder loading pump..... 221
 – Secondary pump..... 230
- Q**
 Quieter operation..... 277
- R**
 Radio clock receiver..... 301
 Raising set temperature
 – Heating water buffer cylinder..... 270
 Raising the set temperature
 – Central heating..... 270
 – DHW heating..... 270
 Rated output of secondary pump..... 231
 Receive interval for data..... 275
 Reduced room temperature..... 241
 Reduced ventilation..... 252, 260
 Reducing set temperature
 – Central cooling..... 270
 Refrigerant..... 138, 140, 142, 144, 145
 Refrigerant circuit..... 137
 – 2-stage..... 210
 Refrigerant circuit controller.....
 15, 23, 137, 139, 141, 143, 145
 – Find type..... 183
 – Hardware index..... 184
 – Identifying..... 183
 – Overview..... 24
 – Software index..... 184
 Refrigerant circuit ID..... 184
 Refrigerant circuit reversal..... 139, 141, 143, 146
 Refrigerant collector..... 141
 Refrigerant collector level sensor..... 306
 Reheating coil..... 63, 128
 – Enable..... 250
 – Enabling..... 64
 Relative humidity..... 129, 133
 Remaining defrost time..... 120
 Remote control..... 241
 Reset..... 195
 Restoring delivered condition..... 195
 Return temperature
 – Primary circuit..... 112, 144
 – Secondary circuit..... 112, 139, 141
 Return temperature raising..... 38
 Return temperature sensor, secondary circuit.....
 149, 172, 301, 302, 308, 309, 310
 Return temperature sensor secondary circuit..... 304
 Reversible suction gas temperature sensor.....
 161, 301, 303
 Ribbon heater..... 307
 Ribbon heater, condensate pan..... 312
 Room temperature..... 117, 254
 – In party mode..... 244
 – Reduced..... 241
 – Standard..... 241
 Room temperature control..... 242
 Room temperature hook-up..... 243
 – Cooling..... 245
 Room temperature influence
 – Cooling..... 247
 Room temperature sensor..... 50, 241
 – Cooling..... 50
 – Separate cooling circuit..... 247, 301, 303
 Run-on time
 – Circulation pump..... 126
 – Secondary pump..... 120
 Runtime..... 147
 – Compressor..... 120
 – Mixer heating circuit..... 243
 Runtime balance..... 31, 199
 Runtime extension, compressor..... 121
- S**
 Safety chain..... 126
 Safety connections..... 289, 292, 294, 296, 299
 Safety functions, external heat generator..... 39
 Safety high pressure switch..... 309
 Saving settings..... 192
 Scope of functions..... 16
 Screed drying..... 227
 Screed program..... 227
 – End day..... 233
 – Start day..... 232
 Seasonal performance factor..... 179
 – DHW..... 179
 – Heating..... 179
 Secondary circuit, minimum flow rate..... 48
 Secondary circuit return temperature.....
 119, 143, 144, 146

Secondary pump.....	308, 309	Smart Grid.....	35
– Manufacturer information.....	231	– Connection to EA1 extension.....	35
– Rated output.....	231	– Connection to heat pump control unit.....	36
– Switching.....	230	– Enable instantaneous heating water heater.....	271
Sensor matching.....	186	– Enabling.....	271
– Extract air temperature.....	258	– Functions.....	36
– Outdoor air temperature sensor.....	258	– Set buffer cylinder temperature.....	272
– Supply air temperature sensor.....	258	– Set DHW heating temperature.....	272
Sensors.....	314	– Set room temperature.....	272
Separate cooling circuit.....	49, 54, 246	Smart Grid (parameter group).....	271
– Ranking, room temperature sensor.....	247	Smart Home system.....	69
– Set room temperature.....	246	Soft starter.....	310
Service level.....	193	Software index	
Service menu.....	193	– Refrigerant circuit controller.....	184
Service PIN.....	187	– Remote control.....	184
Service request.....	184	Software version, scanning.....	183
Service requests.....	184	Solar (parameter group).....	223
Service scans.....	103	Solar absorber.....	26
Service termination.....	193	Solar air absorber.....	206
Set air flow rate		– Hysteresis.....	205
– Background ventilation.....	260, 261, 262	Solar control function.....	43
– Correction factor.....	266	Solar control module.....	43
– Intensive ventilation.....	252, 261	– Type SM1.....	223
– Nominal ventilation.....	252, 261, 262	Solar control unit.....	223
– Reduced ventilation.....	252, 260	Solar DHW heating.....	43
Set buffer temperature.....	114, 116	Solar-Luftabsorber.....	205, 206
Set coolant buffer temperature.....	118	Solenoid valve, intermediate injection.....	141, 306
Set cylinder flow temperature.....	114, 116	Sommerbetrieb Eisspeicher.....	206
Set flow rate		Source, actual room temperature.....	254
– Background ventilation.....	260, 261, 262	Split version.....	17
– Intensive ventilation.....	252, 261	Standard operation.....	58, 65
– Nominal ventilation.....	252, 261, 262	Standard room temperature.....	241
– Reduced ventilation.....	252, 260	Standard setting.....	195
Set flow temperature.....	117	Start delay.....	212
– Cooling.....	118	– Instantaneous heating water heater.....	225
– External demand.....	228	Starting time high efficiency circulation pump.....	232
– Secondary circuit.....	118, 125	Start optimisation.....	218
Set room temperature.....	117, 130, 241, 244, 246, 251	Start threshold.....	121, 122, 126, 229
Set supply air temperature.....	130, 251	– External heat source.....	212
Set system flow temperature.....	114	State machines.....	124, 126
Set temperature, bypass.....	260	Statistics, utilisation of power generated on site.....	180, 181
Set temperature, DHW.....	218	Status change.....	123
Set temperature, extract air.....	251	Status indicators, inverter.....	305
Set temperature reduction		Status information.....	103
– Heating water/coolant buffer cylinder.....	270	Stepper motor, EEV.....	311
Setting aid.....	194	Stop optimisation.....	46, 218
Setting level.....	24	Stop point, compressor.....	148
– Contractor.....	24	Subscriber check.....	187
– System user.....	24	Subscriber number.....	274
Setting range.....	194	Suction gas pressure.....	126, 138, 140, 145
Shutdown limit, heat pump.....	214	Suction gas superheating.....	
Signal connections.....	292, 294, 296	139, 140, 141, 143, 151, 155, 156, 161, 167	
		Suction gas temperature.....	138, 140, 142, 144, 145
		Suction gas temperature sensor.....	
		149, 154, 159, 165, 176, 304, 306, 307, 308, 309,	
		310, 311, 312	
		Summer mode, ice store.....	26, 206, 207
		Summer mode ice store.....	206
		Summertime.....	273

Keyword index (cont.)

- Supercooling of the liquid gas..... 141
- Supply air fan..... 128
- Supply air heating..... 54, 63
- Supply air temperature..... 118
- For bypass..... 252
- Supply air temperature sensor..... 133, 134
- Sensor matching..... 258
- Swimming pool heating..... 56, 199
- Switching state, primary pump..... 198
- Symbols..... 15
- System components.....49
- System components for external changeover.....200
- System configurations.....48
- System definition (parameter group)..... 196
- System examples..... 16
- System flow temperature.....116
- System information..... 23, 183
- System number..... 274
- System overview
- Consumers..... 115
- Generators.....111
- Heat pump cascade..... 119
- System scheme.....196
- T**
- Target temperature control..... 251
- Temperature controller for regulating swimming pool temperature.....56
- Temperature controller for regulating the swimming pool temperature..... 57
- Temperature controller for swimming pool temperature control..... 199
- Temperature controller for swimming pool temperature regulation..... 56
- Temperature range input 0..10V.....203
- Temperature sensor..... 314
- Coefficients, type NTC 10 kΩ..... 314, 317, 318
- Coefficients, type NTC 15 kΩ..... 319
- Coefficients, type NTC 20 kΩ..... 315, 320
- Coefficients, type NTC 50 kΩ..... 321
- Coefficients, type Pt500A.....316
- Drive, inverter..... 152, 177
- Refrigerant circuit controller..... 161, 307
- Temperature sensors..... 301, 302
- Terminals, inverter.....305
- Threshold, output matching.....229
- Threshold for electrical power..... 268
- Time
- Parameter group..... 273
- Restarting ventilation.....256, 257
- Summertime.....273
- Wintertime.....273
- Time, receiving.....275
- Time, send via LON.....276
- Time changeover
- Summertime/Wintertime.....273
- Time interval, filter change..... 133, 135
- Time program
- Quieter operation..... 277
- Screed drying.....227
- Timer..... 120, 126
- Tool binding..... 187
- U**
- Überwachung Absorberkreis.....207
- Use of heat pump in cascade.....199
- User behaviour, DHW heating.....70
- Utilisation of power generated on site..... 69
- Buffer cylinder..... 69, 269
- Buffer cylinder heating..... 71, 72
- Central cooling..... 69, 72, 269, 270
- Central heating.....69, 71
- Compressor output matching..... 70
- DHW heating.....69
- DHW heating statistics..... 181
- Enabling..... 70, 267
- Heating water/coolant buffer cylinder.....269, 270
- Output curves.....182
- Proportion of external power.....267
- Statistics.....180
- V**
- Ventilation.....57, 58, 65, 250, 251
- Diagnosis..... 128, 130
- Flow rate adjustment.....253
- Function scheme.....128
- Message history..... 132, 135
- Parameter group..... 250
- Ventilation heating circuit..... 63
- Ventilation levels..... 58, 65
- Ventilation program..... 58, 65
- Ventilation unit..... 57, 250, 251
- Vitocom 100..... 203
- Vitocomfort 200..... 69, 267
- Vitosolic 200.....26
- Vitotrol 200-A..... 241
- Vitovent 200-C..... 58, 250
- Vitovent 200-W.....65
- Vitovent 300-C..... 65
- Vitovent 300-F..... 58, 250, 254
- Vitovent 300-W.....65
- W**
- Warning..... 74
- Weather-compensated control..... 50
- Wintertime.....273

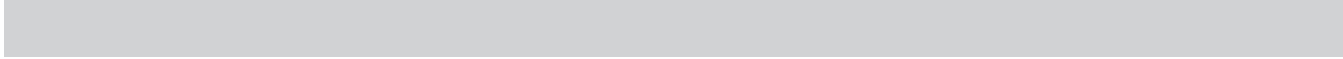



Viessmann Werke GmbH & Co. KG
D-35107 Allendorf
Telephone: +49 6452 70-0
Fax: +49 6452 70-2780
www.viessmann.com



Viessmann Limited
Hortonwood 30, Telford
Shropshire, TF1 7YP, GB
Telephone: +44 1952 675000
Fax: +44 1952 675040
E-mail: info-uk@viessmann.com

6020389 Subject to technical modifications.