

Installation Instructions

for use by heating contractor



Ignition and Ionization Electrode Block

Part Number: 7810719, 7842945, 7870851 Ignition Electrode

Part Number: 7817324 Ionization Electrode

Part Number: 7810720 Gasket (ignition electrode)

For use with: Vitocrossal 200 CM2 186, 246 and 311

Safety and Installation Requirements

Please ensure that these instructions are read and understood before starting any service work. Failure to comply with these instructions may cause product/property damage, severe personal injury and/or loss of life.

Working on the equipment

The installation, adjustment, service and maintenance of this product must be performed by a licensed professional heating contractor who is qualified and experienced in the installation, service, and maintenance of hot water boilers. There are no user serviceable parts on the boiler, burner or control.

Ensure that main power to the equipment being serviced is off.

Ensure that the main fuel supply valve to the boiler is closed.

Take precautions to avoid accidental activation of power or fuel during service work.

Do not perform service work on any component part without ensuring safe operation of the heating system. When replacing parts, use original Viessmann or Viessmann approved replacement parts.



Refer to the Installation and Start-up/Service Instructions applicable to this boiler.

Removing the Front Covers

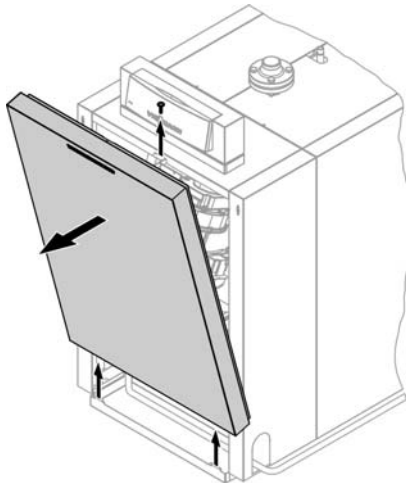

1. Remove the M5 screw and set aside.
2. Pull top of upper front panel forward then lift and remove.
3. Reinstall front covers when finished in reverse order.
Note: Install side cover prior to installing the front covers.



Refer to the Installation and Service Instructions applicable to this boiler.

Removing the Side Cover

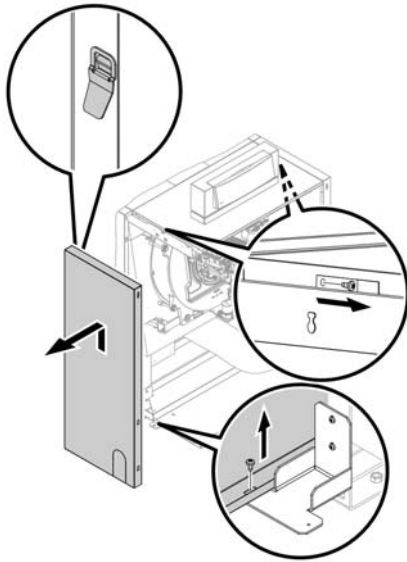

1. Remove the M6 screw (one per panel) on the top rail and bottom support bracket. Then lift up and remove the panel.
2. Reinstall the side cover when finished in reverse order.
Note: Install side cover prior to installing the front covers.



Refer to the Installation and Service Instructions applicable to this boiler.

Ignition Electrode Block

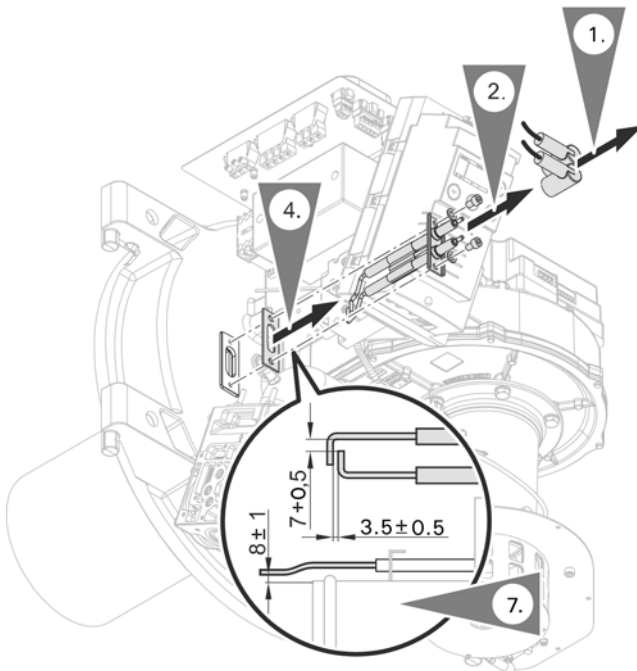

1. Disconnect the ignition cables from the ignition electrodes.
2. Remove the two M6 (5 mm hex) screws and washers from the ignition electrode block and set aside.
3. Remove the ignition electrode block from the burner door.
4. Remove the ignition electrode block gasket from the burner door.
5. Remove the four M12 (19 mm or ¾ in. hex) burner door bolts and washers and set aside.
Note: To access the burner door, disconnect gas line and plugs **40/156**, **53** and **40** from the burner control bracket and plugs **90** and **41** from the burner control.
6. Reinstall the new ignition electrode block and gasket.
7. Open the burner door and check dimensions between electrodes as well as electrode and burner as shown. Carefully adjust if necessary.
8. Reinstall in reverse order.
9. Torque the M12 (19 mm hex socket cap screws) ignition electrode 13 lb.ft (18 Nm).
10. Torque the M6 (5 mm hex) burner door bolts to 35 lb.in (4 Nm).

IMPORTANT

If adjustment to the electrode is necessary, be careful not to damage the ceramic sleeve of the electrode.

! WARNING

Leak test the reconnected gas line.

Ionization Electrode Block

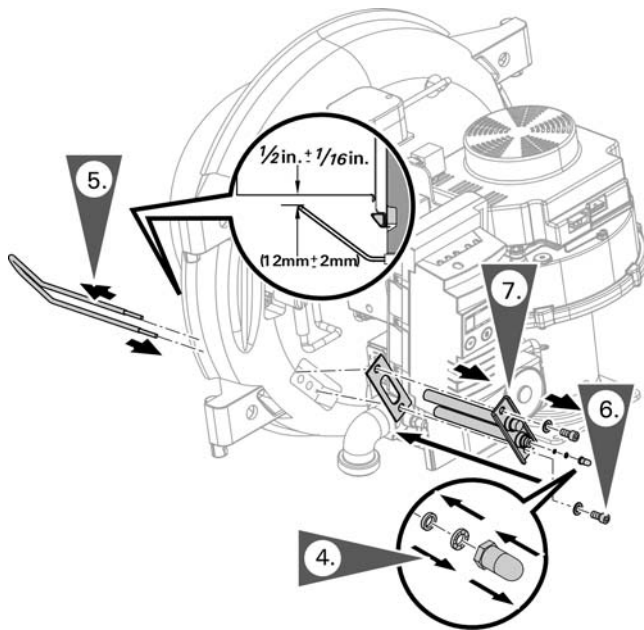

1. Disconnect the ionization cable from the electrode terminal.
2. Remove the four M12 burner door bolts (19 mm or 3/4 hex wrench) and washers and set aside.

Note: To access the burner door, disconnect gas line and plugs 40/156, 53 and 40 from the burner control bracket and plugs 90 and 41 from the burner control.

3. Open the burner door.
4. Remove ionization electrode terminal nut (hex 7 mm). Remove serrated washer and O-ring.
5. Remove the inside portion of the ionization electrode.
6. Remove the two M6 screws (5 mm hex socket cap) and washers from ionization electrode block and discard it.
7. Remove the ionization electrode block and gasket from burner door.
8. Reinstall in reverse order use only new parts supplied in the kit.
9. Check the dimension between the electrode and burner as shown. Carefully adjust if necessary.
10. Torque the M12 (19 mm hex) burner door bolts to 13 lb.ft (18 Nm).
11. Torque the M6 (5 mm hex socket cap screws) ionization electrode 35 lb.in (4 Nm).

IMPORTANT

If adjustment to the electrode is necessary, be careful not to damage the ceramic sleeve of the electrode.

WARNING

Leak test the reconnected gas line.

Printed on environmentally friendly
(recycled and recyclable) paper.



Technical information subject to change without notice.

Viessmann Manufacturing Company Inc.
750 McMurray Road
Waterloo, Ontario • N2V 2G5 • Canada
TechInfo Line 1-888-484-8643
1-800-387-7373 • Fax (519) 885-0887
www.viessmann.ca • info@viessmann.ca

Viessmann Manufacturing Company (U.S.) Inc.
45 Access Road
Warwick, Rhode Island • 02886 • USA
TechInfo Line 1-888-484-8643
1-800-288-0667 • Fax (401) 732-0590
www.viessmann-us.com • info@viessmann-us.com