

Installation and service instructions

for contractors

VIESSMANN

Vitodens 100

Type WB1A

Gas fired wall mounted condensing boiler

Natural gas version

For applicability, see the last page



VITODENS 100



Safety instructions



Please follow these safety instructions closely to prevent accidents and material losses.

Safety instructions explained



Danger

This symbol warns against the risk of injury.



Please note

This symbol warns against the risk of material losses and environmental pollution.

Note

Details identified by the word "Note" contain additional information.

Target group

These instructions are exclusively designed for qualified personnel.

- Work on gas equipment must only be carried out by a CORGI registered gas fitter.
- Electrical work must be compliant with Part P of the building regulations
- The system must be commissioned by the system installer or a qualified person authorised by the installer.

If you notice the smell of gas



Danger

Escaping gas can cause explosions which may lead to serious injury.

- Do not smoke. Prevent naked flames and sparks. Never operate light switches or those of electrical equipment.
- Open windows and doors.
- Close the gas shut-off valve.
- Remove all personnel from the danger zone.
- Observe the safety regulations of your local gas supplier, found on the gas meter.
- Notify your heating contractor from outside the building.

If you smell flue gas



Danger

Flue gas may lead to life-threatening poisoning.

- Heating system shutdown
- Ventilate the boiler room.
- Close all doors leading to the living space.
- Do not operate electrical switches.

Safety instructions (cont.)

Working on the heating system

- Isolate the system from the mains electric power supply, e.g. by removing a separate fuse or by means of a mains electrical isolator, and check that it is no longer 'live'.
- Isolate the gas supply and safeguard against unauthorised reopening.

Repair work



Please note

Repairing components which fulfil a safety function can compromise the safe operation of your heating system. Replace faulty components only with original Viessmann spare parts.

Ancillary components, spare and wearing parts



Please note

Spare and wearing parts which have not been tested together with the heating system can compromise its function. Installing non-authorised components and non-approved modifications/conversion can compromise safety and may infringe our warranty conditions.

For replacements, use only original spare parts from Viessmann or those which are approved by Viessmann.

Index

Installation instructions

Preparing for installation

Product information	5
Preparing for installation	5

Installation sequence

Installing the boiler and making all connections	31
Flue outlet	38
Electrical connections	40
Commissioning and testing	45

Service instructions

Commissioning, inspection, maintenance	55
---	----

Service Instructions

Routine Servicing Instructions	55
--------------------------------------	----

Troubleshooting

Fault finding	66
Repairs	70

Designs

Connection and wiring diagrams – combi boiler	78
Connection and wiring diagram - system boiler	80

Parts lists	82
--------------------------	----

Commissioning/service reports	88
--	----

Certificates

Declaration of conformity	92
---------------------------------	----

Keyword index	93
----------------------------	----

Product information

Vitodens100, WB1A

Set up for operation with natural gas.

Preparing for installation

General Information

Appliance description

The Vitodens 100 is a fully automatic, wall hung, fan assisted balanced flue condensing boiler for use with natural gas (G20).

The Vitodens 100 is fully modulating and provides central heating outputs between 8.0 kW (27.300Btu/h) and 24.0 kW (84.300Btu/h)/30.0 kW (93.550 Btu/h) and instantaneous hot water at outputs between 8.0 kW (27.300 Btu/h) and 24.0 kW (84.300Btu/h)/30.0 kW (93.550 Btu/h).

The appliance always gives priority to domestic hot water supply.

The appliance is designed for use with sealed primary water systems (only) and incorporates a circulation pump, diverter valve assembly, flow switch (combi boiler only), DHW plate-type heat exchanger (combi boiler only), safety valve and CH expansion vessel. A separate DHW expansion vessel is not required. Internal frost protection and an electronic control unit is fitted as standard equipment and the boiler may be used with any suitable room thermostat and / or time clock in addition to the optional controls available from Viessmann.

Asbestos, mercury or CFC's have not and will not be used in this product.

Certification details

The Vitodens 100 is certified to comply with the requirements of prEN 483 and EN 625 for use in GB and IE (Great Britain and Ireland) using gas category 2H (G20 with a governed gas supply at 20 mbar (8 in.wg) inlet pressure).

The appliance classification is either C13x or C33x depending upon whether a horizontal or vertical flue terminal is used.

Preparing for installation

Preparing for installation (cont.)

Technical Specification

General Specifications and Performance Data

Rated output range			
T_v/T_r 50/30 °C	kW	8 to 24	8 to 30
T_v/T_r 80/60 °C	kW	7.3 to 21.8	7.3 to 27.3
Rated output range	kW	7.4 to 22.3	7.4 to 28.0
Maximum gas rate	m ³ /h	2.36	2.96
Combi boiler:			
Design domestic hot water performance (specific rate)	l/min	8.0	10.0
Domestic hot water temperature range	°C	30 - 60	30 - 60
Maximum mains water inlet pressure	bar	10	10
Minimum mains water inlet pressure for operation	bar	1	1
Total water capacity (including expansion vessel)	l	3.5	3.5
Minimum CH system pressure (static head) – Cold	bar	1.0	1.0
Maximum CH system pressure (static head) – Hot	bar	3.0	3.0
Maximum CH flow temperature	°C	80	80
Integral expansion vessel capacity	l	8	8
Integral expansion vessel pre-charge pressure	bar	0.75	0.75
Lift weight			
- Combi boiler	kg	43	43
- System boiler	kg	42	42
Total weight inc. packaging			
- Combi boiler	kg	48	48
- System boiler	kg	47	47
Electrical supply		230 V, 50Hz	230 V, 50Hz
Internal fuse	A	4	4
Maximum power consumption	W	145	145
Flue outlet (clearance Ø):	mm	60	60
Ventilation pipe (outside Ø)	mm	100	100
Gas Council Number			
- Combi boiler		47-819-04	47-819-05
- System boiler		41-819-09	—
Product ID		CE-0085 BQ 0017	

5862 881 GB

Preparing for installation (cont.)

Overall Appliance Dimensions

Combi boiler

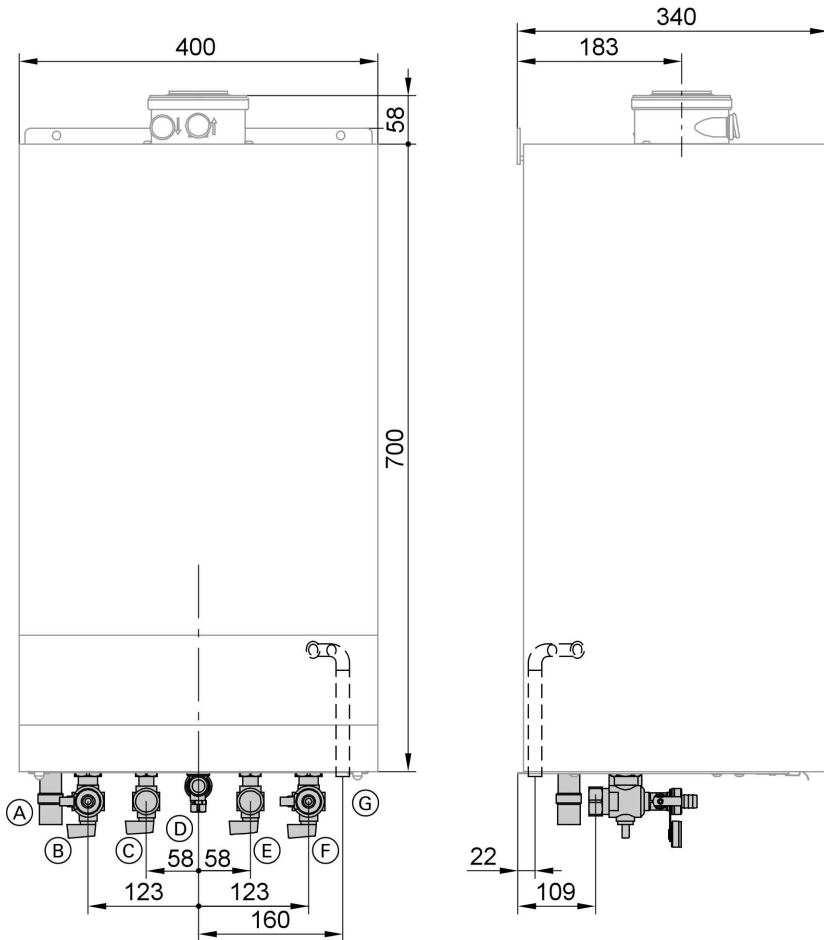

- (A) Condensate drain: Plastic pipe
Ø22 mm
- (B) Heating flow: Ø22 mm
- (C) DHW: Ø15 mm

- (D) Gas connection: Rp ½"
- (E) Cold water: Ø15 mm
- (F) Heating return: Ø22 mm
- (G) Safety valve drain: Ø15 mm

5862 881 GB

Installation

Preparing for installation

Preparing for installation (cont.)

System boiler

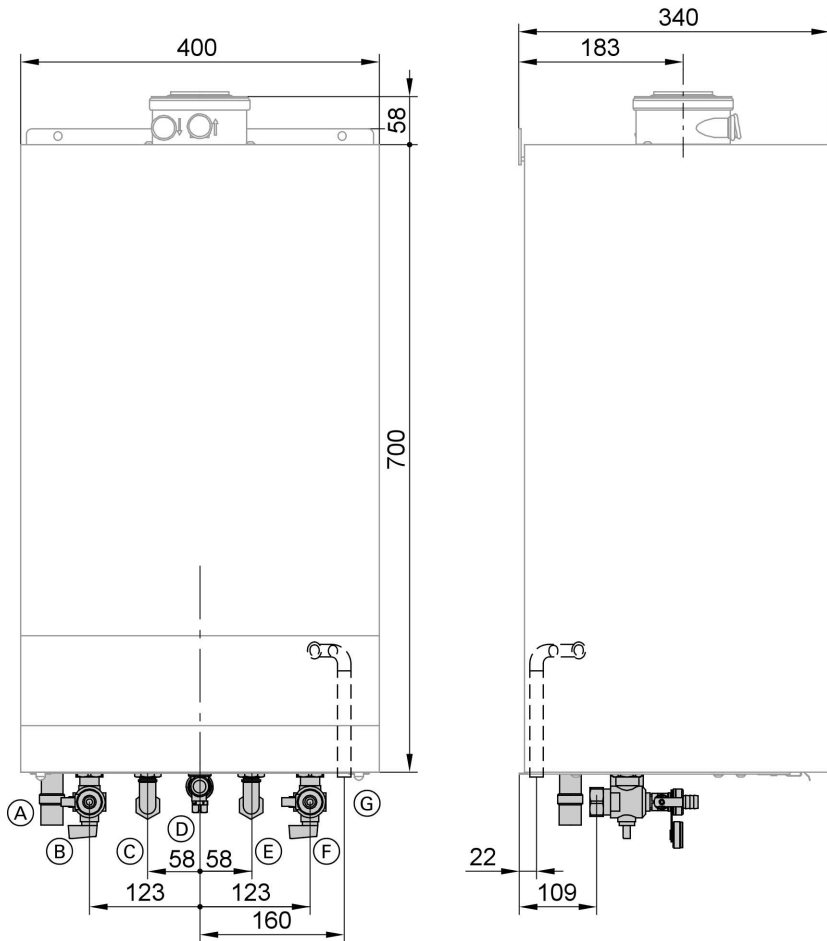

- (A) Condensate drain: Plastic pipe
Ø22 mm
- (B) Heating flow: Ø22 mm
- (C) DHW cylinder flow: Ø22 mm

- (D) Gas connection: Rp ½"
- (E) DHW return: Ø22 mm
- (F) Heating return: Ø22 mm
- (G) Safety valve drain: Ø15 mm

Preparing for installation (cont.)

Minimum installation clearances

The following minimum clearances (mm) must be maintained for installing and servicing the appliance.

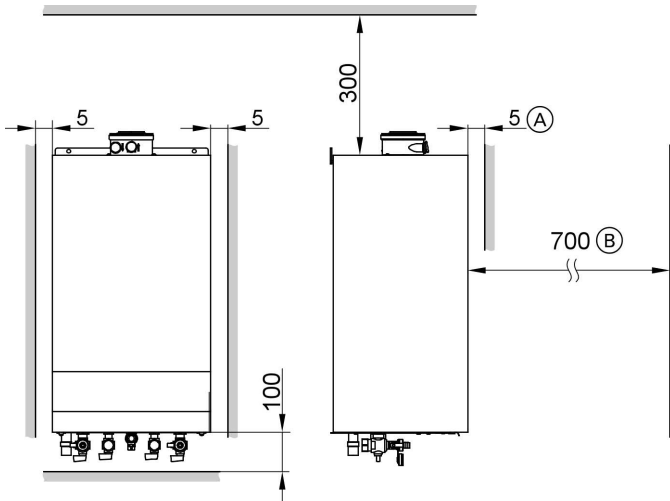

(A) Front (behind removable panel)

(B) Front (for service)

Flue System Specifications

Concentric Horizontal Flue System

Standard horizontal flue kit: The appliance can be supplied complete with a standard concentric horizontal flue terminal assembly, suitable for flue lengths of up to 620 mm from the centre of the flue outlet, which equates to wall thicknesses of up to 480 mm for rear flues and 463 mm for side flues, including minimum clearances.

Extension ducts can be used to increase the straight flue length up to 6 m and include one 87° elbow.

Preparing for installation

Preparing for installation (cont.)

An extra 87° elbow can be used but this reduces the maximum permissible length by 1 m . An extra 45° elbow can be used but this reduces the maximum permissible length by 0.5 m .

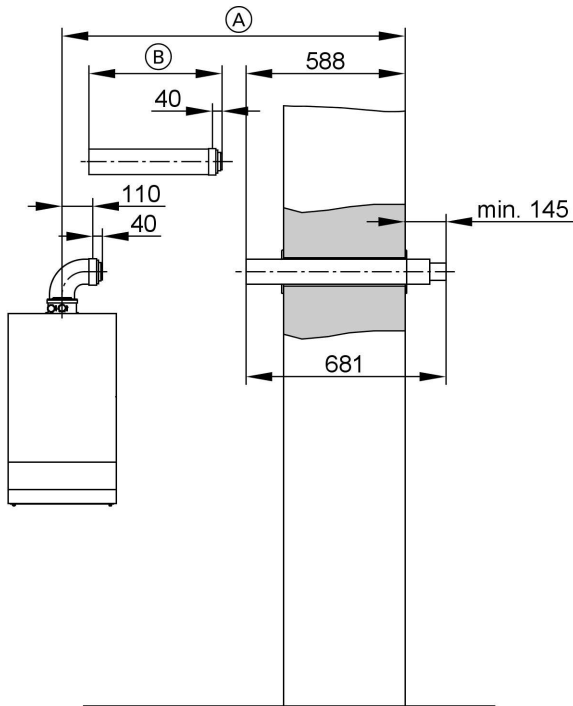

(A) Combined length of flue outlet/ventilation pipe max 6m.

(B) Flue outlet/ventilation pipe (can be shortened as necessary)

Concentric Vertical Flue System

The vertical flue kit (optional extra) with extensions may be used for up to 10 m applications.

An extra 87° elbow can be used but this reduces the maximum permissible length by 1 m . An extra 45° elbow can be used but this reduces the maximum permissible length by 0.5 m .

5862 881 GB

Preparing for installation (cont.)

Before commencing the installation refer to diagram below to determine which optional extension kits are required, if any.

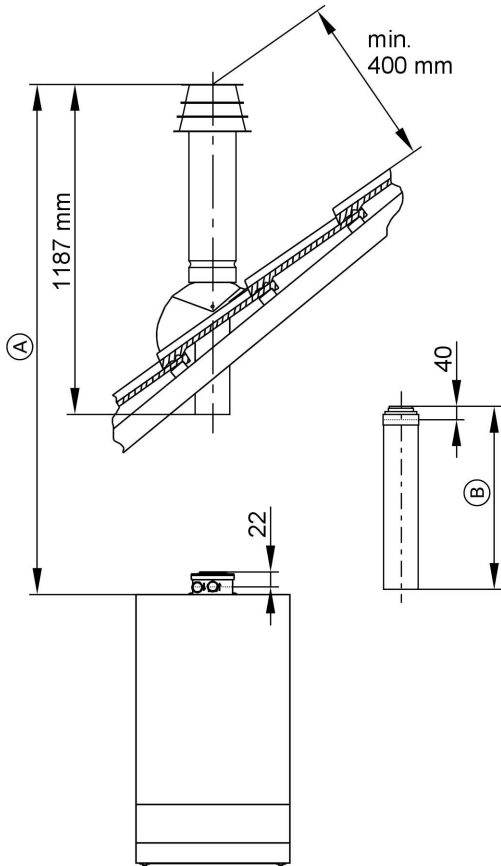

Ⓐ Combined length of flue outlet/ventilation pipe max. 10 m.

Ⓑ Flue outlet/ventilation pipe (can be shortened as necessary)

Preparing for installation

Preparing for installation (cont.)

Elbows and extensions

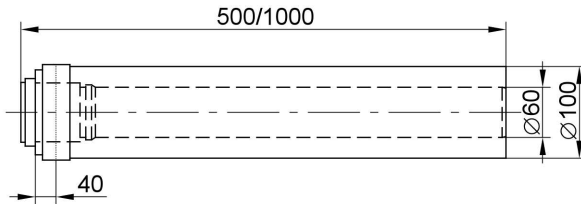

Extension

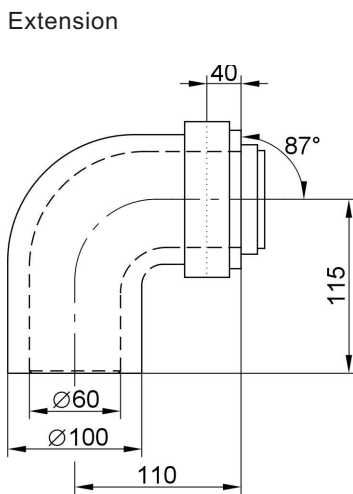

Elbow 87°

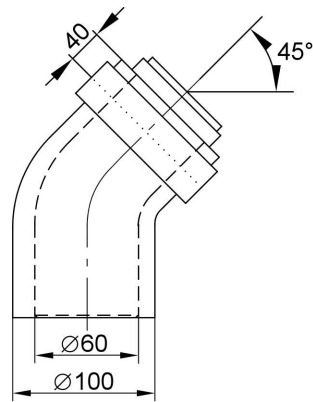

Elbow 45°

Preparing for installation (cont.)

Hydraulic circuit

Combi boiler

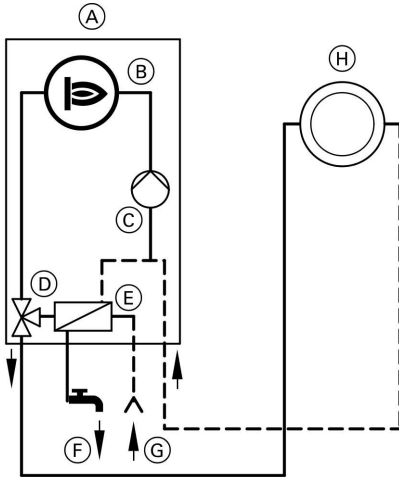

- Ⓐ Boiler
- Ⓑ heat exchanger
- Ⓒ circulation pump
- Ⓓ Three-way diverter valve

- Ⓔ Plate-type heat exchanger
- Ⓕ DHW outlet
- Ⓖ Cold water inlet
- Ⓗ Heating circuit

Installation

Preparing for installation

Preparing for installation (cont.)

System boiler

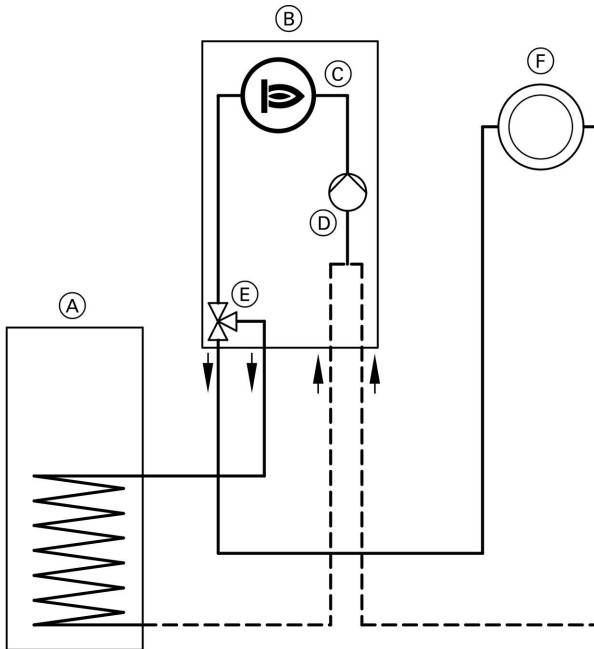

- Ⓐ DHW cylinder
- Ⓑ Boiler
- Ⓒ heat exchanger

- Ⓓ circulation pump
- Ⓔ Three-way diverter valve
- Ⓕ Heating circuit

Preparing for installation (cont.)

Sectional Diagram

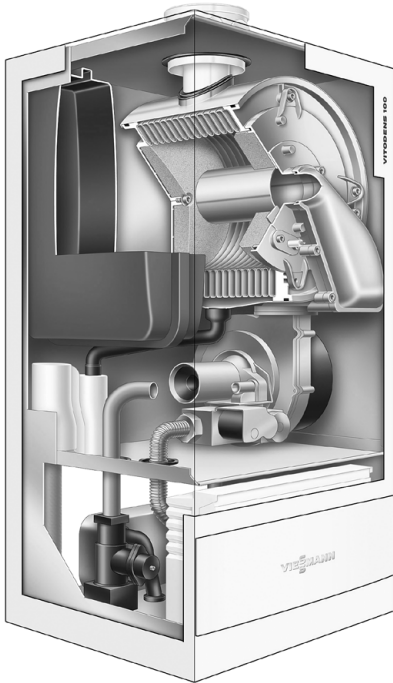

Combi boiler illustrated

Installation Requirements

Statutory Requirements

Gas safety (installation and use) regulations (current issue)

It is in your own interest and safety, to ensure that the law is complied with.

Preparing for installation (cont.)

In addition to the above regulations, this appliance must be installed in accordance with the current IEE Wiring Regulations for electrical installation (BS 7671), local building regulation, the Building Standards (Scotland) (Consolidation) Regulations, bye laws of the local water undertaking and Health and Safety Document No. 635 'The Electricity at Work regulations 1989'.

It should also be in accordance with the relevant recommendations in the current editions of the following British Standards and Codes of Practice: BS 5449, BS 5546, BS 5440:1, BS 5440:2, BS 6798, BS 7593, BS 6891 and IGE/UP/7.

From 1 April 2005, all CORGI Registered Installers will be required to notify CORGI when they have installed or exchanged a gas appliance in a residential dwelling.

CORGI will then issue either a Building Compliance Certificate (for England and Wales) or a Declaration of Safety (for Scotland, Northern Ireland, Isle of Man or appliances out of the scope of Building Regulations) to the homeowner, which will confirm that the work has been carried out by a competent CORGI Registered Installer. This document will be used to form part of the Home Information Pack (HIP) that becomes a requirement from January 2007 in order to sell your house.



Please note

Manufacturers instructions must not be taken in any way as overriding statutory obligations.

Boiler Position

The following limitations must be observed when siting the boiler:

- The boiler is not suitable for external installation. The position selected for installation should be within the building, unless otherwise protected by a suitable enclosure and must allow adequate space for installation, servicing and operation of the appliance and for air circulation around it.
- This position must allow for a suitable flue system and terminal position. The boiler must be installed on a flat vertical wall capable of supporting the weight of the appliance and any ancillary equipment when full.

- Due consideration should be given to the routing of the condensate drain from the chosen position.
- If the boiler is to be fitted in a timber framed building it should be fitted in accordance with the British Gas publication 'Guide for Gas Installations In Timber Frame Housing', reference DM2. If in doubt, advice must be sought from British Gas.



Preparing for installation (cont.)

- If the appliance is to be installed in a room containing a bath or shower, any electrical switch or control utilising mains electricity, it must be so situated, that it cannot be touched by a person using the bath or shower. Attention is drawn to the requirements of BS 7671 (the current I.E.E Wiring Regulations) and in Scotland the electrical provisions of the Building Regulations applicable in Scotland.
- A compartment used to enclose the appliance must be designed and constructed specifically for this purpose. An existing cupboard or compartment may be used provided it is modified accordingly. BS 5376:2 gives details of the essential features of cupboard / compartment design, including airing cupboards
- Where installation will be in an unusual location, special procedures may be necessary. BS 6798 gives detailed guidance on this aspect.

Flue terminal position
Horizontal flue system

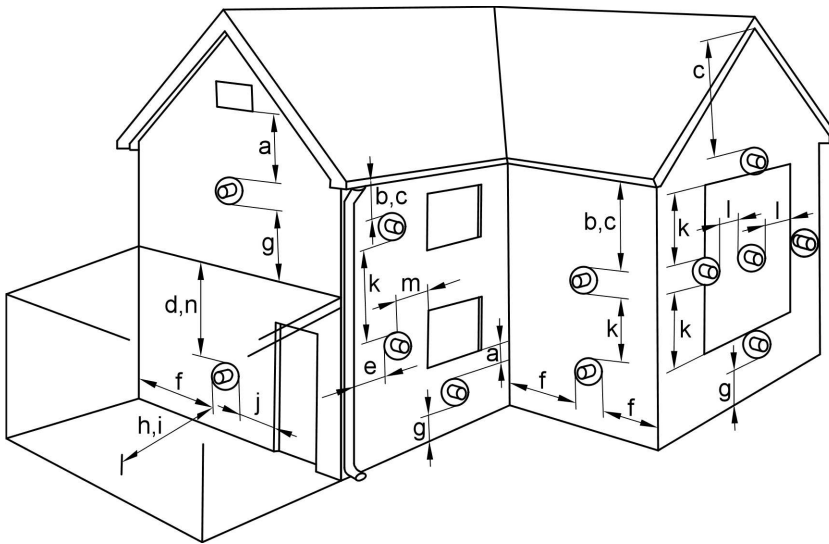

Position		Minimum spacing mm
a	Directly below an window that can be opened, air vent or any other ventilation opening	300
b	Below gutter drain or soil pipe	75

5862 881 GB

Installation

Preparing for installation

Preparing for installation (cont.)

Position		Minimum spacing
		mm
c	Below eaves	200
d	Below a balcony	200
e	From vertical drain or soil pipes	150
f	From internal and external corners	300
g	Above adjacent ground or balcony level/roof	300
h	From a surface facing the terminal	600
i	Facing terminals	1200
j	From opening door/window in carport into dwelling	1200
k	Vertically from a terminal on same wall	1500
l	Horizontally from a terminal on same wall	300
m	Adjacent to opening	300
n	Below carport/roof	200

Vertical flue systems

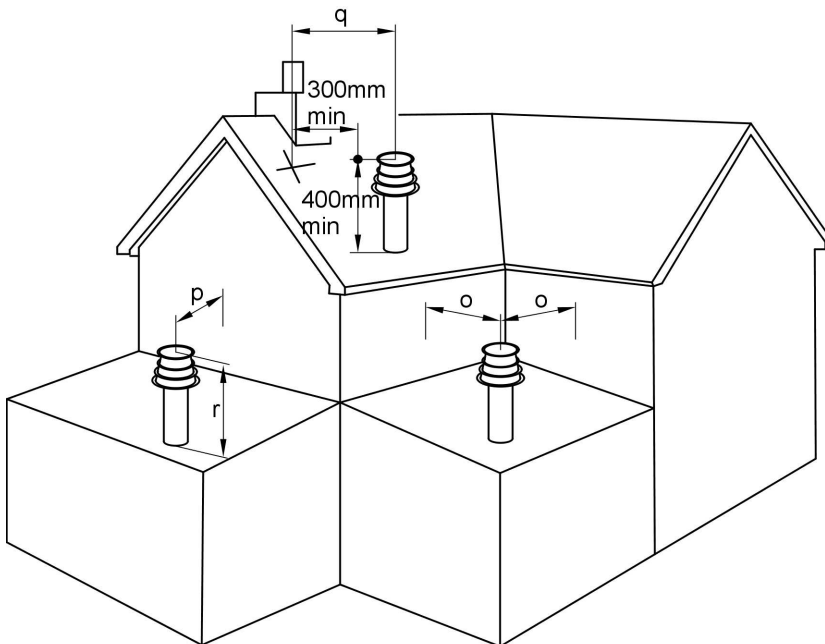

Preparing for installation (cont.)

Position		Minimum spacing mm
o	From adjacent wall	300
p	From adjacent opening window	1000
q	From another terminal	600
r	Minimum height	300

Flue Terminal Location

Detailed recommendations for flue installation are given in BS 5440:1. The following notes are for general guidance.

- The boiler must be installed so that the terminal is exposed to external air.
- It is important that the position of the terminal allows free passage of air across it at all times.
- It is essential to ensure that products of combustion discharging from the terminal cannot re-enter the building or any other adjacent building, through ventilators, windows, doors, other sources of natural air infiltration or forced ventilation / air conditioning.
- The minimum acceptable dimensions from the terminal to obstructions and ventilation openings are specified in on page 16(BS 5440 Part 1).
- If the terminal discharges into a pathway or passageway check that combustion products will not cause nuisance and that the terminal will not obstruct the passageway.
- Where the lowest part of the terminal is fitted less than 2 m above ground, above a balcony or above a flat roof to which people have access, the terminal must be protected by a purpose designed guard. (Available as an optional extra).
- Where the terminal is fitted within 850 mm of a plastic or painted gutter, or 450 mm of painted eaves, an aluminium shield, at least 750 mm long, must be fitted to the underside of the painted surface.
- The air inlet / flue outlet duct must not be closer than 25 mm to combustible material.
- Due to the high efficiency of the boiler the terminal may emit a plume of vapour. This is normal but positions where this would cause a nuisance should be avoided.

Installation

Preparing for installation (cont.)

Ventilation Requirements

Detailed recommendations for air supply are given in BS 5440:2. The following notes are for general guidance.

- It is not necessary to have a purpose provided air vent in the room or internal space in which the appliance is installed.
- If the boiler is to be installed in a cupboard or compartment, no permanent air vents are required for cooling purposes in the cupboard or compartment, however, it is essential to ensure that the minimum clearances stated in page 9 are maintained.

Central Heating System (typical system designs)

- The Vitodens 100 is designed for connection to sealed central heating water systems.
- A sealed system must only be filled by a competent person.
Filling the heating system see page 47.

Combination boiler

Note

The boiler incorporates an internal bypass to ensure adequate water flow. Certain thermostatic radiator valve manufacturers may require that a bypass valve is fitted in addition to the integral bypass. Specifications as to the individual requirements should be sought prior to installation.

Preparing for installation (cont.)

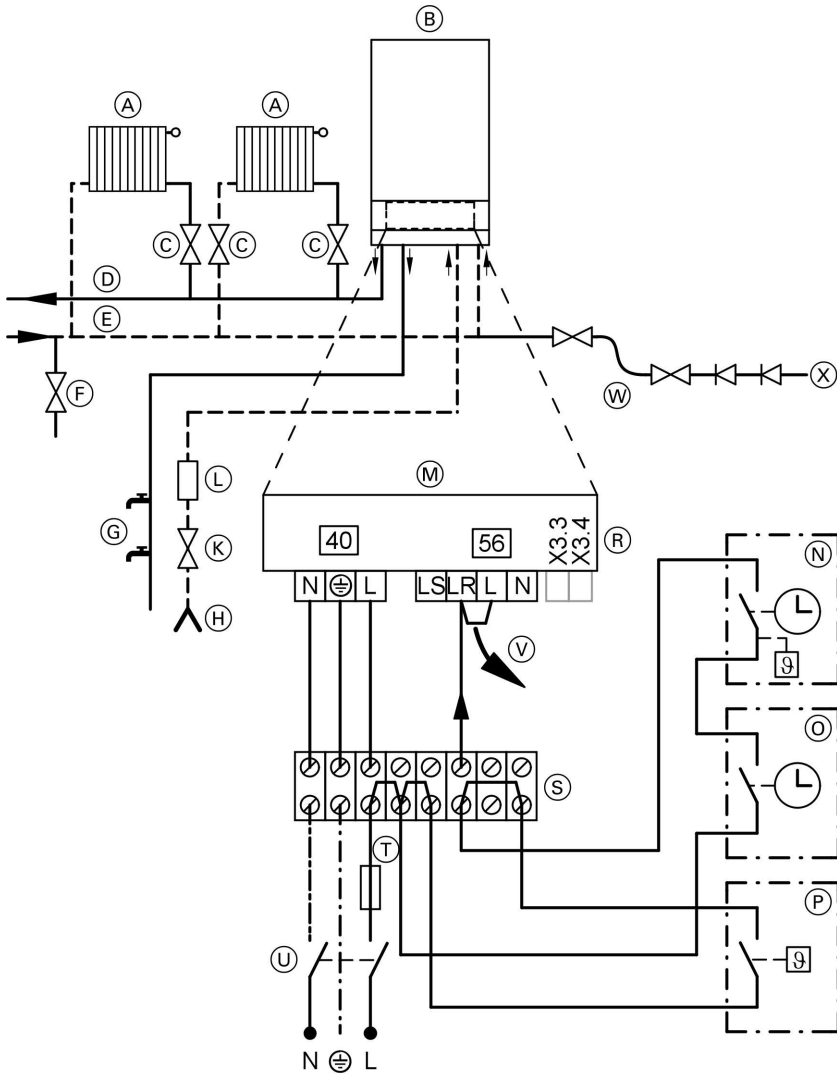

5862 881 GB

- (A) Radiators
- (B) Boiler
- (C) Lockshield valve
- (D) CH flow
- (E) CH return

- (F) Drain cock at lowest point in the system
- (G) Hot water taps
- (H) Water main
- (K) BS stop valve

Installation



Preparing for installation

Preparing for installation (cont.)

- Ⓛ Pressure reducing valve (if necessary)
 - Ⓜ Control unit
 - Ⓝ Room temperature control (on site)
Connection of Viessmann Vitotrol 100 see page 41
 - Ⓞ Time switch
 - Ⓟ Frost stat
 - Ⓡ Open therm-connection (alternative)
Connection see page 41
 - Ⓢ Connection box (not supplied)
 - Ⓣ Fuse 3 A
 - Ⓤ Mains ON/OFF switch
 - Ⓥ When connecting, remove jumper
 - Ⓦ Temporary filling loop
 - Ⓧ Water mains
 - 40 Power supply
 - 56 Mains connection accessories/
room temperature control/DHW
cylinder control
 - LR Connection of room temperature
control
 - LS Connection of DHW cylinder control
- The following Viessmann control configurations are available:
 - Constant temperature
 - Timer with constant temperature
 - Vitotrol 100 UTD
 - The boiler requires a permanent live feed via plug 40.

System boiler

Cylinder connected directly to boiler.

Note

The boiler incorporates an internal bypass to ensure adequate water flow, however one radiator should be permanently open (fitted with two lockshield valves) to dissipate any excess heat.

Preparing for installation (cont.)

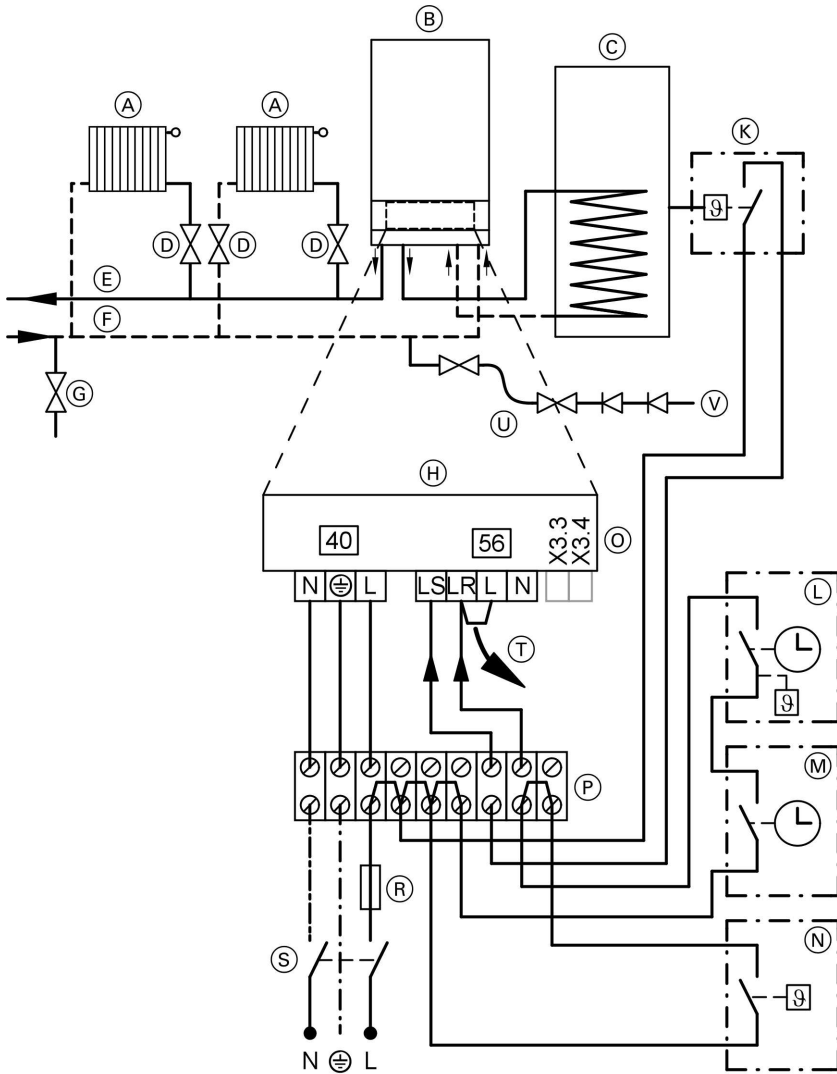

5862 881 GB

- (A) Radiators
- (B) Boiler
- (C) DHW-Cylinder
- (D) Lockshield valve
- (E) CH flow

- (F) CH return
- (G) Drain cock at lowest point in the system
- (H) Control unit
- (K) Cylinder thermostat

Installation



Preparing for installation

Preparing for installation (cont.)

- Ⓛ Room temperature control (on site)
Connection of Viessmann Vitotrol 100 see page 41
 - Ⓜ Time switch
 - Ⓝ Frost stat
 - Ⓞ Open therm-connection(alternative)
Connection see page 41
 - Ⓟ Connection box (not supplied)
 - Ⓡ Fuse 3 A
 - Ⓢ Mains ON/OFF switch
 - Ⓣ When connecting, remove jumper
 - Ⓤ Temporary filling loop
 - Ⓥ Water mains
 - 40 Power supply
 - 56 Mains connection accessories/
room temperature control/DHW
cylinder control
 - LR Connection of room temperature
control
 - LS Connection of DHW cylinder con-
trol
- The following Viessmann control configurations are available:
Constant temperature
Timer with constant temperature
Vitotrol 100 UTD
 - The boiler requires a permanent live feed via plug 40.
 - The DHW cylinder must have an integrated temperature control connected to the Vitodens 100
 - The DHW will always take priority over the central heating when timed demand is selected.

Hydraulic components in the boiler

Pump

The available head shown in following figure is that in excess of the appliance hydraulic resistance, i.e that available for the system.

Preparing for installation (cont.)

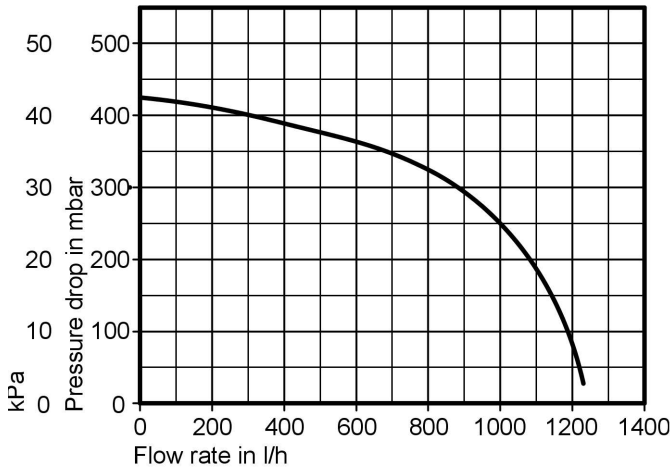

Expansion vessel

The table shows the maximum system volume that the integral expansion vessel can sustain under different charge pressure conditions. If the system volume exceeds that shown, an additional expansion vessel must be fitted and connected to the heating system primary return pipe as close as possible to the appliance. If an extra vessel is required, ensure that the total capacity of both vessels is adequate.

Further details are available in the current issues of BS 5449 and BS 6798.

If the pressure gauge rises by 1.5 bar when the appliance is at maximum temperature with all radiators in circulation an extra expansion vessel is required.

Vessel charge and initial system pressure	bar	0.5	1.0	1.5
	psi	7.3	14.5	21.5
Total water content of system using 8 litre capacity expansion vessel supplied with appliance	litres	106	75	42
	gallons	23	16.5	9
For systems having larger capacity, multiply the total system capacity in litres by the factor to obtain the total minimum expansion vessel capacity required		0.0833	0.11	0.16

5862 881 GB

Preparing for installation (cont.)

Pressure relief valve

A pressure relief valve set at 3 bar (43.5 psi) is supplied with the appliance.

Domestic Hot Water System (Combi boiler only)

- Check that the mains water pressure is sufficient to produce the required DHW flow rate of 9.0 l/min (24 kW)/12.0 l/min (30 kW), but does not exceed the maximum DHW pressure (10 bar). If necessary, a pressure reducing valve must be fitted to the mains supply before the DHW inlet connection.
- The final 600 mm (24 in) of the mains supply pipe to the boiler must be copper.
- A regulator is fitted to control the maximum water flow rate.
- If the appliance is installed in an area where the temporary hardness of the water supply is high (over 150 ppm) the fitting of an in line scale inhibitor may be an advantage. Consult the Local Water Authority if in doubt.
- For specific information relating to fittings (e.g.. showers, washing machines etc) suitable for connection in the DHW circuit, consult the Local Water Authority. However, the following information is given for guidance.
Domestic hot/cold water supply taps and mixing taps: All equipment designed for use at mains water pressure is suitable.
Showers and bidets: Any mains pressure shower or bidet complying with the Local Water Authority regulations is suitable.

Gas Supply

- The Gas Supplier should be consulted at the installation planning stage in order to establish the availability and supply of an adequate supply of gas.
- A gas meter can only be connected by the gas supplier or by their contractor.
- An existing meter and / or pipework should be of sufficient size to carry the maximum boiler input plus the demand of any other installed appliance. (BS 6891: 1988). A minimum of 22 mm dia. pipework is required to within 1 metre of the appliance gas cock.
- The governor at the meter must give a constant outlet pressure of 21 mbar +/- 1mbar. when the appliance is running.



Preparing for installation (cont.)

- The gas supply line should be purged.
Warning: Before purging open all doors and windows, also extinguish any cigarettes, pipes and any other naked lights.
- The complete installation must be tested for gas soundness.

Electricity Supply

- Wiring external to the appliance must be in accordance with BS 7671 (the current I.E.E Wiring Regulations) for electrical installation and any local regulations which apply.
- The mains cable must be at least 0.75 mm^2 (24/0.2 mm) PVC insulated to BS 6500 table 16.
- **Warning:** This Appliance must be earthed. (Failure to provide a satisfactory earth connection would be a safety hazard and may also result in appliance malfunction).
- The method of connection to the mains supply must facilitate complete electrical isolation of the appliance. Either a 3A fused three pin plug and unswitched shuttered socket outlet, both complying with BS 1363, or a 3A fused double-pole switch having a 3 mm contact separation in both poles and serving only the boiler (and its external controls) may be used.

External Controls

To ensure optimum performance, Viessmann offer a range of external controls however the appliance may be used with any certificated room thermostat or time clock room thermostat.

Preparing for installation

Preparing for installation (cont.)

Preparations for boiler installation

Unpacking the appliance

The appliance is supplied in 2 separate packages plus any optional flue packages. Check the availability and contents of each package before commencing the installation.

Boiler package

Combi boiler

- Boiler (assembled)
- 5 shut-off valves
- Wall mounting fixture
- 2 wall plugs and 2 screws
- Installation template

System boiler

- Boiler (assembled)
- 3 shut-off valves
- 2 connection elbows
- Wall mounting fixture
- 2 wall plugs and 2 screws
- Installation template

Wall mounting bracket installation

Important: Before installing the appliance, check that the chosen position is suitable, adequate installation clearances are available and that the requirements for flue terminal position are satisfied.

Preparing for installation (cont.)

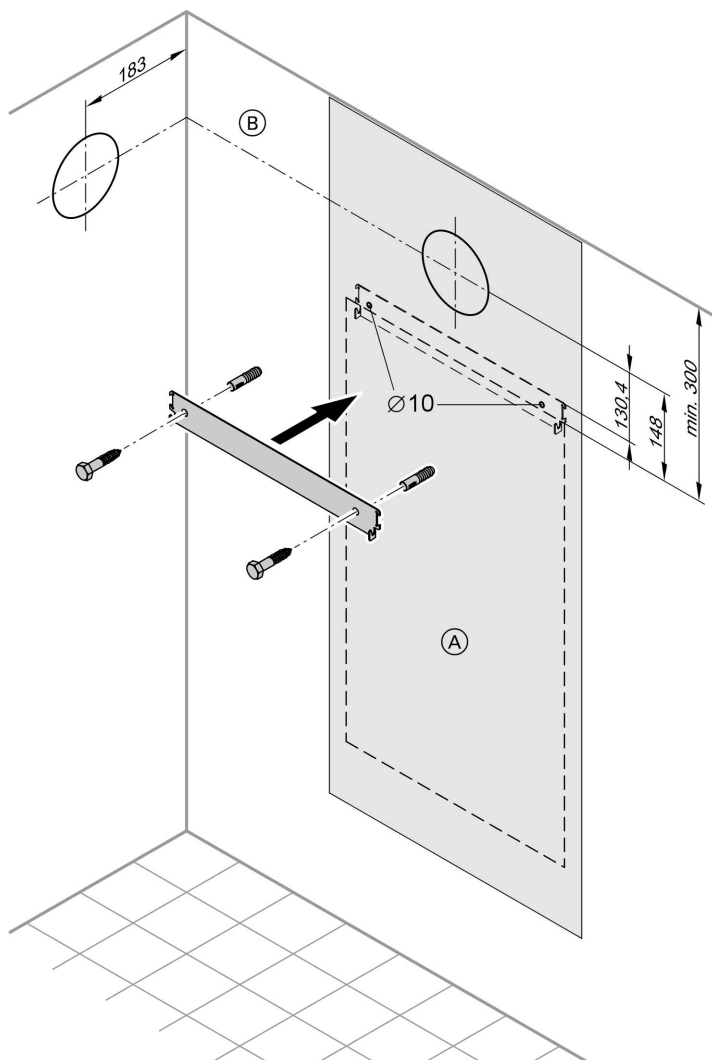

Installation

(A) Installation template

(B) Observe the minimum slope of 3° (5mm/m) towards the boiler

5862.881 GB

1. Position the installation template on the wall.

2. Mark wall plug holes and balanced flue pipe opening.



Preparing for installation

Preparing for installation (cont.)

3. Drill \varnothing 10 mm holes and insert the rawl plugs.
4. Cut flue pipe opening to 100 mm \varnothing .
5. Fit wall mounting frame with enclosed screws.

Preparing the connections

Note

For dimensions for on-site preparations of the gas and water side connections see "Overall Appliance Dimensions" on page 7.

1. Prepare the water connections.
2. Clean and flush the heating system.
Use only the following additives:
 - Cleanser (Ferrox)
 - Sentinel X300...
3. Prepare gas connection to BS 6891.
4. Prepare the electrical connections.
 - Mains cable: H05V2V2-F 3 G 1.0 mm², 230 V~, 50 Hz.
A 1.5m power cable is part of the standard delivery.
 - Accessory cables: H05V2V2-F 3 G 1.0 mm² for connection of room temperature control and DHW cylinder control (system boiler).

Installing the boiler and making all connections

Remove front panel and mount boiler

Note

The front panel must be removed before mounting the boiler.

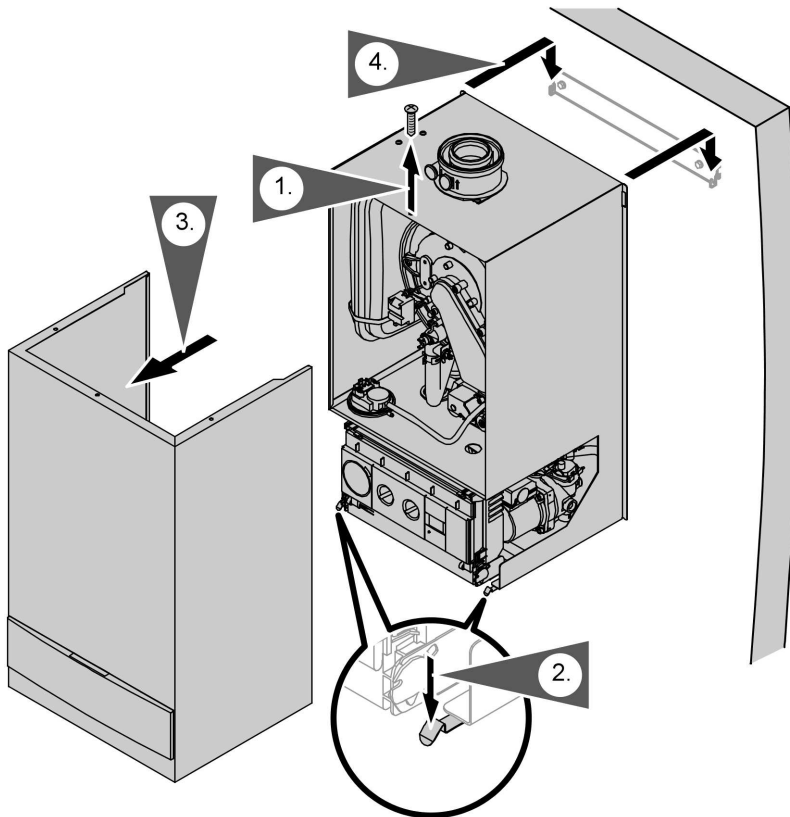

1. Remove the screw at the top of the boiler.
2. Press down the springs on the underside of the boiler and remove the front panel.
3. Hook the boiler on to the wall mounting frame.

Installation sequence

Installing the boiler and making all connections (cont.)

Gas connection

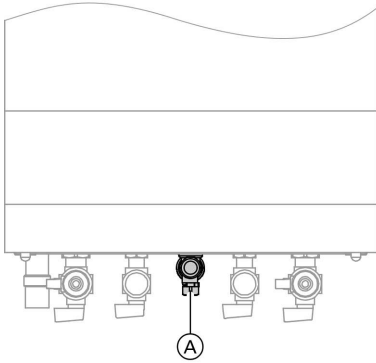

1. Connect the gas supply to the gas inlet connection on the gas cock (A). Upon completion, tighten the union connection.
2. Carry out a gas soundness test.
3. Purge the gas supply pipe.

(A) Gas connection: ½" BSP

Installing water fittings

Combi boiler

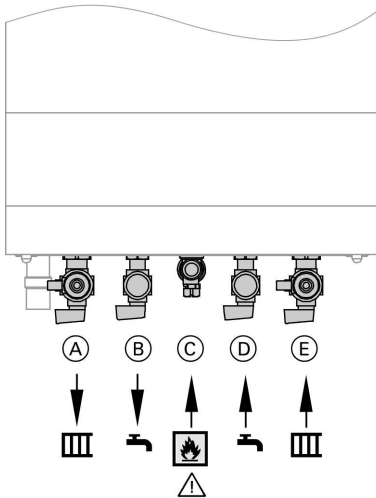

Installing the boiler and making all connections (cont.)

- (A) Heating flow: \varnothing 22 mm (red toggle)
- (B) DHW: \varnothing 15 mm
- (C) Gas connection: $\frac{1}{2}$ " BSP
- (D) Cold water: \varnothing 15 mm
- (E) Heating return: \varnothing 22 mm (blue toggle)

System boiler

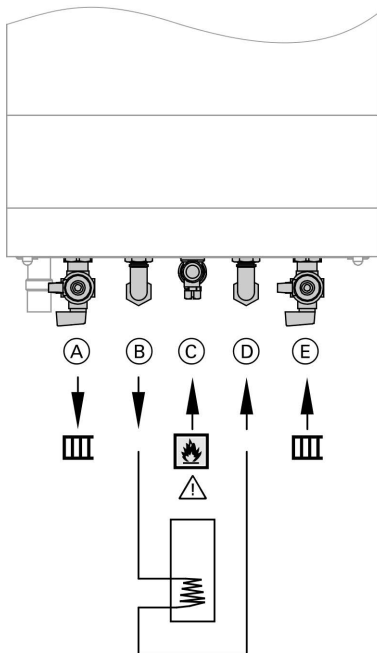

Note

For operation without a DHW cylinder, shut-off connections (B) and (D).

- (A) Heating flow: \varnothing 22 mm (red toggle)
- (B) DHW cylinder flow: \varnothing 22 mm
- (C) Gas connection: $\frac{1}{2}$ " BSP
- (D) DHW return: \varnothing 22 mm
- (E) Heating return: \varnothing 22 mm (blue toggle)

Installing the boiler and making all connections (cont.)

Connect safety valve drain

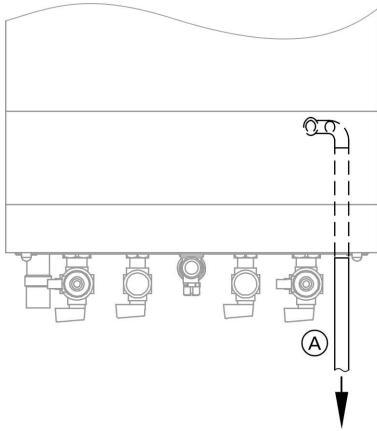

Ⓐ \varnothing 15 mm

Connect a suitable discharge pipe to the pressure relief valve outlet. The pipe discharging to a safe place must be a minimum of 15 mm copper and run continually downwards.

The pipe from the pressure relief valve must not discharge above an entrance, window or any type of public access area.

The pipe must be routed to a position so that any discharge of water possibly boiling, or steam, cannot create any danger to persons, damage to property or external electric components and wiring. The point of discharge must be clearly visible.

To ease future servicing it is advisable to use a compression type fitting to extend the discharge pipe.

Installing the boiler and making all connections (cont.)

Condensate connection

Vitodens 100 has within a syphonic condensate trap.

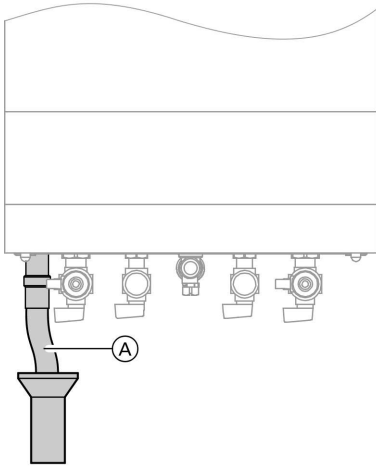

Ⓐ Ø22 mm plastic condensate pipe

Routing

The condensate pipe can terminate into any one of the following areas. It is always the best practice to terminate the condensate pipe via an internal waste system.

- The pipe run should take the shortest practical route with a downward slope of at least 2.5° (4.5 mm/m)
- The external pipework should be insulated to prevent freezing
- The pipework should terminate as close as possible to the ground or drain, whilst still allowing the condensate to safely disperse.
- The condensate pipe must be of non corrosive material, preferably plastic. Note: ferrous materials or copper must not be used.

Installation sequence

Installing the boiler and making all connections (cont.)

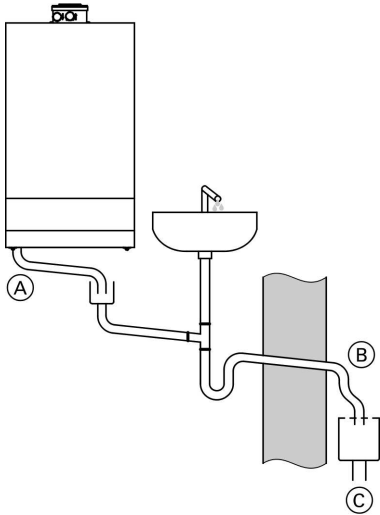

Terminating into an internal waste system

- (A) \varnothing 22 mm plastic condensate pipe
- (B) External length of pipe 3 m max.
- (C) Open end direct into gully, below ground but above water level

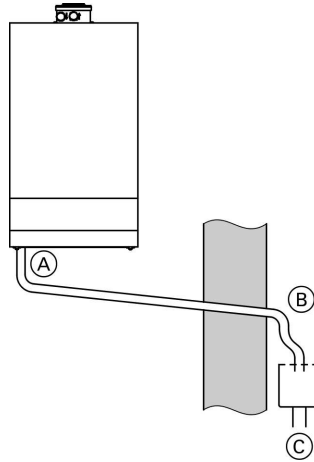

Terminating into an external waste system

- (A) \varnothing 22 mm plastic condensate pipe
- (B) External length of pipe 3 m max.
- (C) Open end direct into gully, below ground but above water level

Installing the boiler and making all connections (cont.)

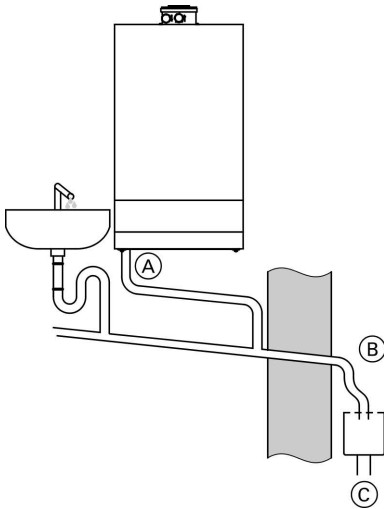

Terminating into an external purpose made soakaway

- (A) Ø22 mm plastic condensate pipe
- (B) External length of pipe 3 m max.
- (C) Open end direct into gully, below ground but above water level

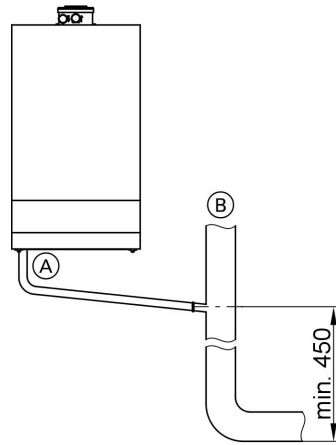

Terminating into the rainwater system

- (A) Ø22 mm plastic condensate pipe
- (B) Internal soil and vent stack

Installation

Filling the siphon with water

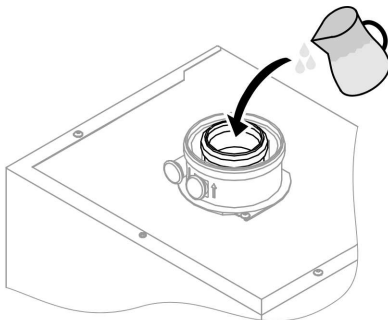

Fill a minimum of 0.3 l of water into the boiler connect kit flue outlet.



Please note

At initial start-up, flue gas may be emitted from the condensate drain.
Fill the siphon with water before start-up.

Flue outlet

External wall terminal C13x

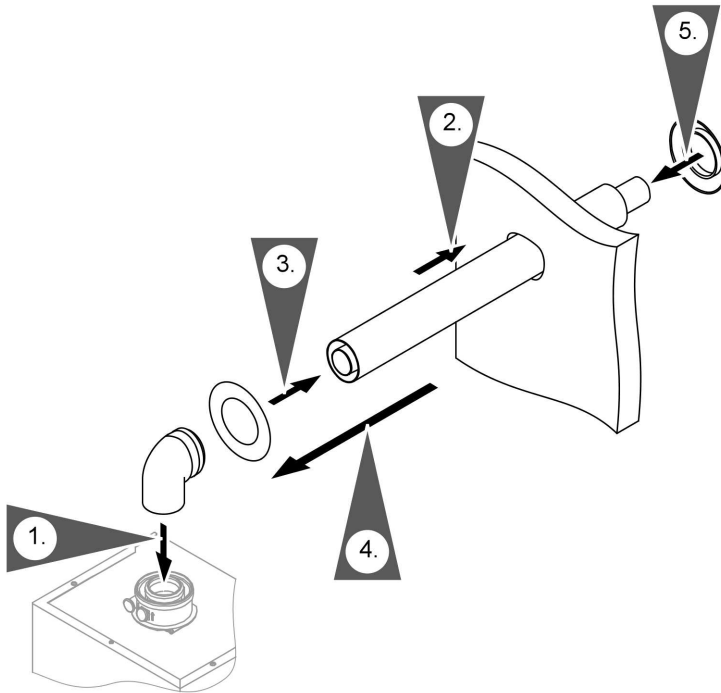

1. Insert pipe bend into the boiler flue outlet.
2. Insert external flue terminal into the wall outlet.
3. Secure the wall bezel internally.
4. Connect external flue terminal to pipe bend.
Install flue and supply pipes accordingly, with a minimum of 3° slope (ca. 50 mm/m) towards the boiler.
5. Secure the wall bezel externally.

Flue outlet (cont.)

Vertical roof terminal C33x

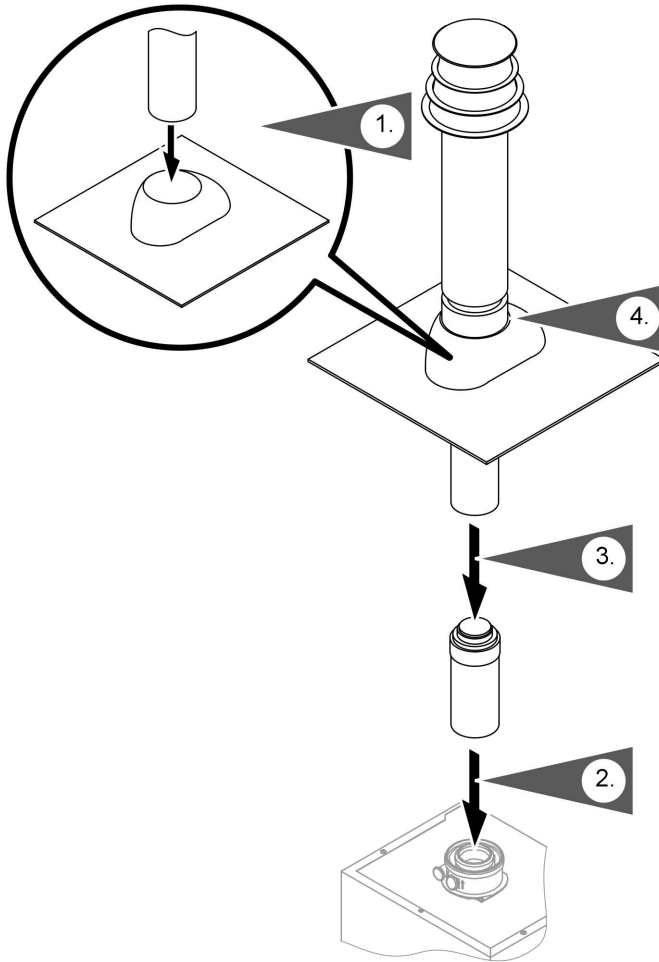

1. Install the universal roof tile.
2. Install flue and supply pipes accordingly.

3. Push roof terminal through roof and insert into flue/supply pipe.
4. Seal roof terminal.

Installation sequence

Electrical connections

Opening the control unit housing

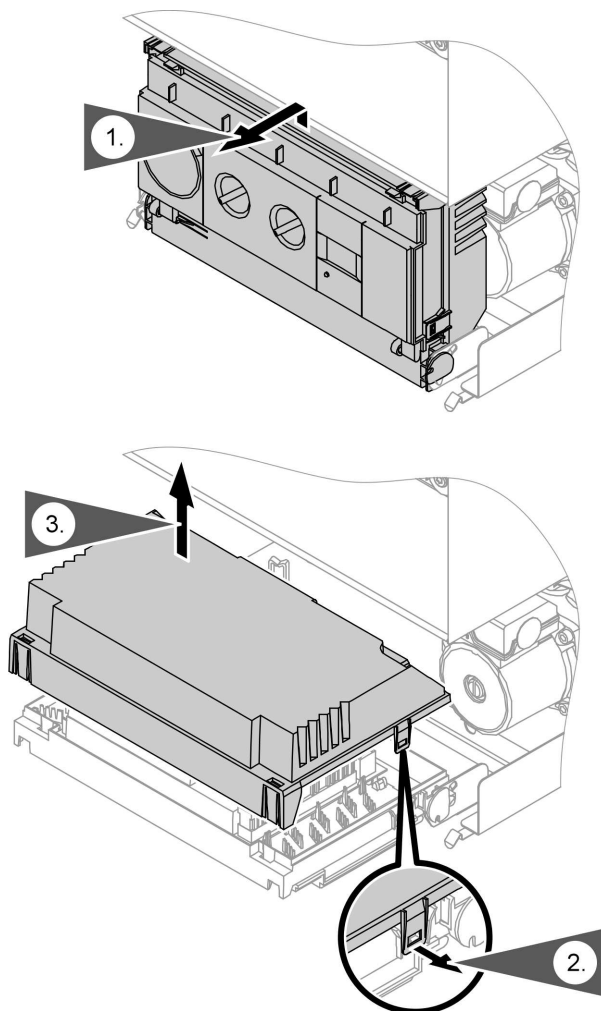

Electrical connections (cont.)

Making connections



Notes regarding the connection of accessories

For details of accessories, also observe the separate installation instructions provided.

Notes regarding the connection of room temperature and DHW cylinder temperature control

For more information about the connection of on site temperature controls see page 20.

Electrical connections (cont.)

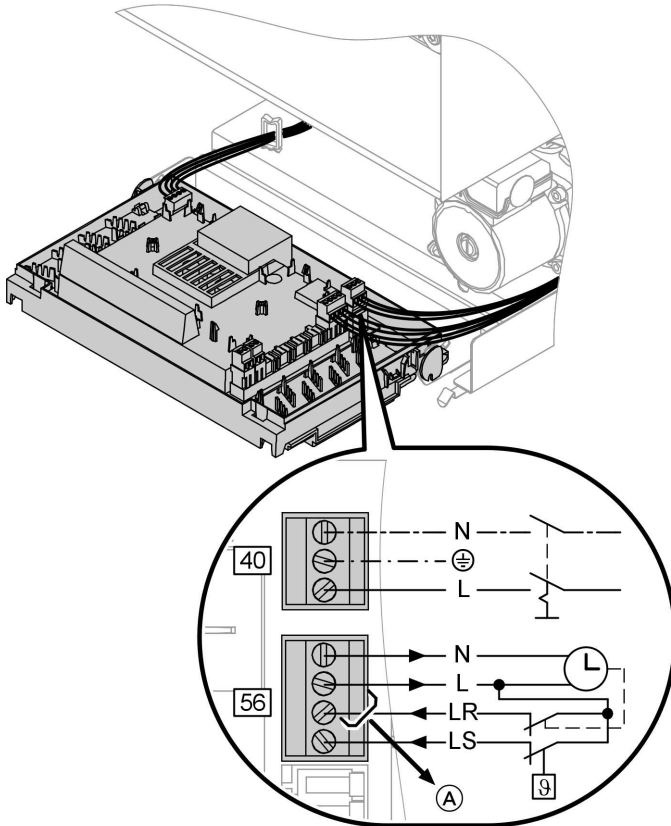

- 40** Mains power connection 230 V ~ 50 Hz (green plug)
Do not interchange the supply conductors L1 and the neutral conductor N.
A two pole shut off switch with a contact separation of at least 3 mm must be fitted in the mains supply to the boiler with a maximum fuse value of 3 A.
A 1.5m power cable is part of the standard delivery.

- 56** Mains connection accessories/
room temperature control/DHW
cylinder control (black plug)
- (A)** If making the connection between, "L" and "LR" remove jumper **56**.
- LR Connection of room temperature control
- Vitotrol 100 UTA
 - Vitotrol 100 UTD
- LS Connection of DHW cylinder control

Electrical connections (cont.)

Connect DHW cylinder temperature control

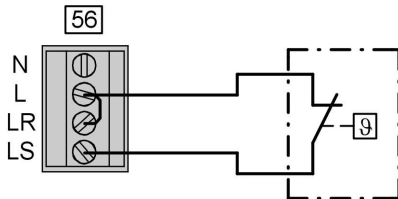

Connect Vitotrol 100

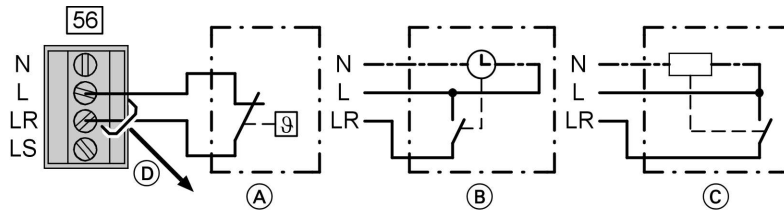

- (A) Vitotrol 100 UTD
- (B) Vitotrol 100 UTA
- (C) Vitotrol 100 RT
- (D) When connecting, remove jumper

Routing connecting cables

- ! **Please note**
Connecting cables can be damaged if they touch hot components. When routing and securing connecting cables on site, ensure that the maximum permissible cable temperatures are not exceeded.

Installation

Installation sequence

Electrical connections (cont.)

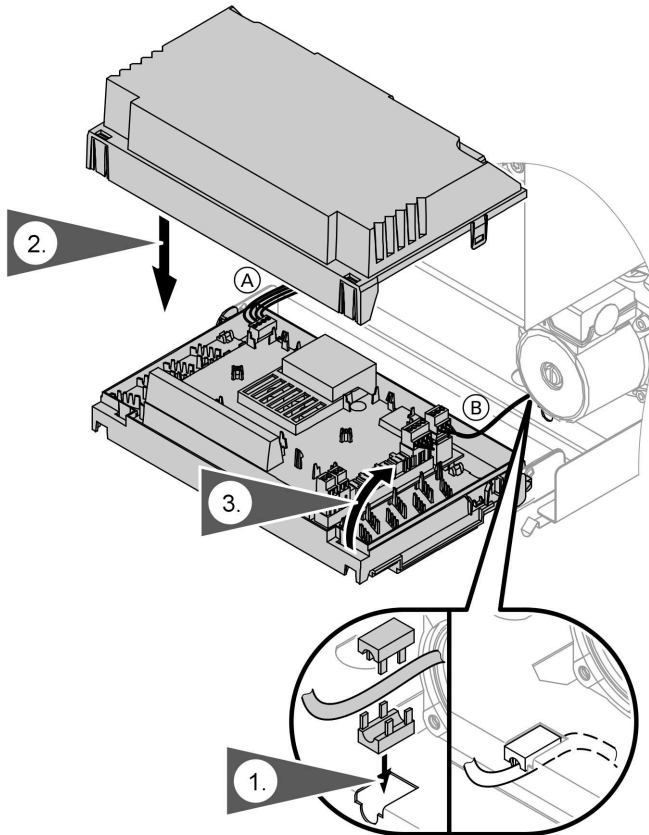

Ⓐ Low voltage connections

Ⓑ 230 V connections

1. Connect strain relief to the external cable and clip into the mounting plate aperture.

2. Fit cover.

3. Pivot the control unit upwards.

Electrical connections (cont.)

Front panel installation

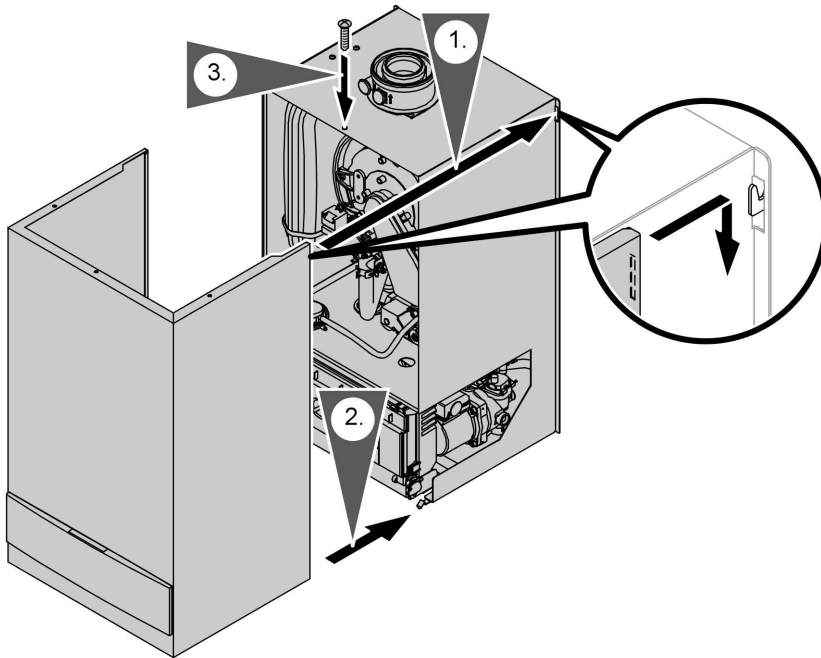

1. Hang the front panel to the wall mounting frame by the appropriate hook.
2. Press down the front panel at the bottom.
3. Insert the screw at the top of the boiler.

Note

The outer case forms a seal with the combustion box. It must therefore be securely fitted with the screw provided.

Commissioning and testing

Before commissioning the appliance, the whole gas installation including the meter must be purged and tested for gas soundness in accordance with BS 6891: 1988.

Commissioning and testing (cont.)



Danger

Open all doors and windows; extinguish naked lights and **do not smoke** whilst purging the gas line.

Before commencing the commissioning procedure, ensure that the gas service cock is turned on, the electricity supply is isolated and that the DHW and CH pipework is complete.

Fill the system with cold water. It may be convenient to carry out this procedure before fitting the boiler to the piping frame. Vent the system via the radiator valves and system air vents in accordance with normal practice, close all air vents and check for system soundness. Drain the entire system to flush out any debris.

Additives from the approved list below may be used. The use of non approved additives will invalidate the warranty on this product.

- Anti-scaling: Sentinel X200
- Anti-bacterial:
 - System Cleaner (Fernox)
 - Sentinel X300...
- Antifreeze:
 - Glycol (30% max.)
 - Antifreeze (Fernox)
 - Sentinel X500...
- Anti-corrosion:
 - Inhibitor (Fernox)
 - Sentinel X100...
- Cleaner:
 - Cleanser (Fernox)
 - Sentinel X300...

Do not use non approved additives or any chemicals from the following list

- Boiler noise silencer
- Leak sealer
- Fuel, Oil, Grease, Washing powder/liquid
- pipe jointing compound (like boss white and boss green, Sentinel)
- Anti-blockage

Note

Additive combinations are permitted only if approved additive suppliers recommend it and always according to supplier's dosage recommendation.

It is essential that the procedure below is followed to ensure that all the air in the boiler heat exchanger and the system is completely vented prior to firing the appliance.

Commissioning and testing (cont.)

Filling the heating system



Please note

Unsuitable fill water increases the level of deposits and corrosion and may lead to boiler damage.

- Thoroughly flush the entire heating system prior to filling with water.
- Only use fill water of potable quality.
- Soften fill water harder than 150 ppm temporary hardness.
- Inhibitors or antifreeze additives suitable for heating systems should be injected or added manually.

1. Close the gas shut-off valve.
2. Only when operating with DHW cylinder: Prevent heat demand from the DHW cylinder.
3. Switch on mains supply and turn rotary selectors "⏻" and "⏻" counterclockwise to the end stop (turn selector "⏻" only for system boiler).

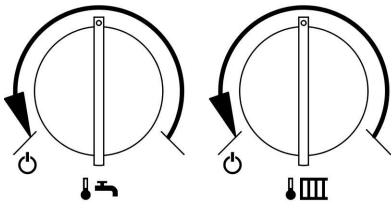

Note

The display will show the actual operating pressure and the circulation pump is switched on.



Commissioning and testing (cont.)

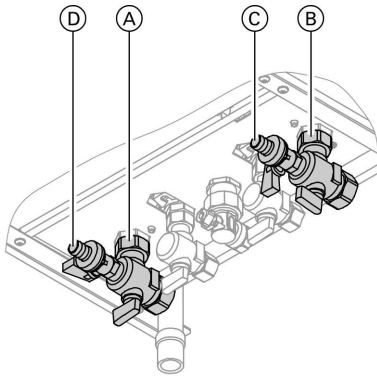

4. Close the shut off valves (A) and (C) to prevent water leaving the boiler (toggle at 90° to the pipe). Connect a hose pipe to outlet (D) ready to vent the boiler later.
5. Turn valve (B) to the draining position (toggle to the front). This will allow the system pressure reading to be displayed on the boiler control panel.
6. Fill and vent the system through your external temporary filling loop ensuring that most of the air has been removed from all drain and vent points on the system.

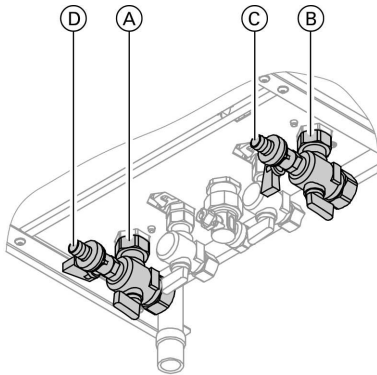

7. Turn on valve (B) (toggle to the rear) to allow water into the boiler and at the same time turn valve (A) to the draining position (toggle to the front) with the drain toggle open (a jubilee type clip will ensure no water loss and secure the hose in place on the drain point).
8. Fill heating system. (minimum system pressure > 1.0 bar). The actual system pressure is displayed electronically on the boiler display.

Commissioning and testing (cont.)

Venting the boiler by flushing out (after venting system)

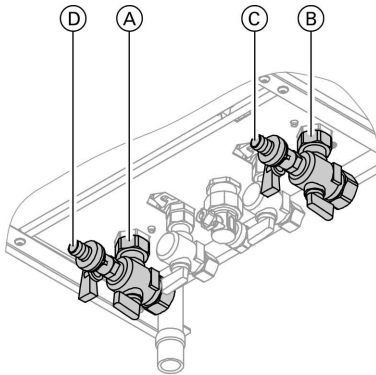

1. Leaving the hose connections from filling the system continue to fill the boiler from the external filling loop and draining the water to a drain from connection (D).
2. Continue flushing the water through the boiler until no air pockets are discharged out of the drain hose.
3. Slowly turn off the valve (D) and turn off the temporary filling loop to regulate the pressure in the boiler and system to approx 1.2 bar.
4. Turn valve (A) to open position (toggle to rear).
5. Turn on the appliance to circulate the pump in both DHW and CH positions in order to continue venting.

Note

It is essential that there is no air in the heat exchanger and the system prior to firing the appliance. This will cause an F7 fault and prevent you finishing the installation without hinderance.

After 12 minutes the electronic board switches into the DHW modus. Turn rotary selector "⬇️ IIII" clockwise for two seconds into the middle position, then turn rotary selector "⬇️ IIII" counterclockwise back to the end stop.



Commissioning and testing (cont.)

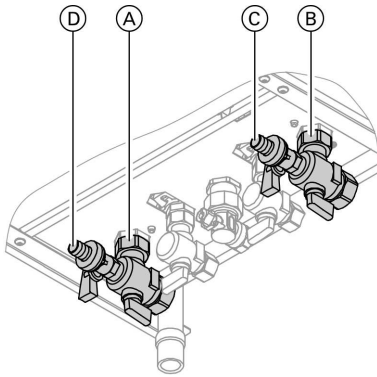

6. Ensure both isolation valves (A) and (B) to operating position (toggle to the rear), seal with the caps provided.

7. Turn temperature gauge controls to the desired operating position.

Note

Be aware that the boiler may still need to be vented as air pockets are drawn into the heat exchanger.

8. Turn rotary selectors "⏴ III" and "⏴ II" into control range again (turn selector "⏴ III" only for system boiler).

Filling the Domestic Hot Water Circuit (Combi boiler only)

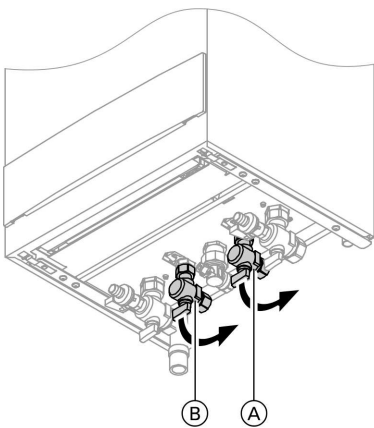

1. Open the DHW inlet valve (A) and outlet valve (B).

2. Open all DHW taps in turn to vent any air from the DHW pipework.

Commissioning and testing (cont.)

Checking static and supply pressure



Danger

CO formation, as a result of incorrect burner adjustment, can lead to severe health problems.

Carry out a CO test prior to, and after, work on gas equipment.

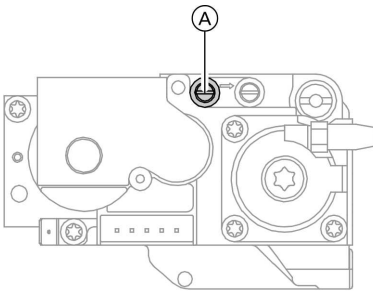

1. Close the gas shut-off valve.
2. Release the screw inside test nipple "IN" (A) on the gas combination valve, but do not remove, and connect the pressure gauge.
3. Open the gas shut-off valve.
4. Check the static pressure; it should be 20 mbar +/- 1mbar.
5. Switch on mains voltage and start up the boiler.

Note

During commissioning, the boiler can enter a fault state because of airlocks in the gas pipe.

To reset press "1" key. The ignition procedure will then be repeated.

6. Check the inlet working pressure = 20 mbar.
 - Minimum working pressure = 12 mbar
 - Maximum working pressure = 20 mbar

Note

Use suitable test equipment, with a resolution of at least 0.5 mbar, to measure the supply pressure.



Commissioning and testing (cont.)

7. Shut down the boiler, close the gas shut-off valve, remove the pressure gauge, and close test nipple (A) with the screw.
8. Open the gas shut-off valve and start the boiler.



Danger

Gas escaping from the test nipple leads to a risk of explosion.

Check test nipple (A) for soundness.

Domestic hot water flow rate and temperature (Combi boiler only)

A flow regulator is fitted to ensure that no adjustment of maximum flow is necessary.

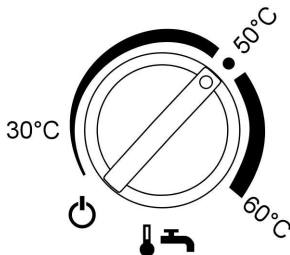

Setting DHW temperature:

Set rotary selector  to the desired DHW temperature.

Comfort funktion (Combi boiler only)

When the comfort function is selected, the instantaneous water heater will be held at temperature (standby). This makes DHW available quickly.

Commissioning and testing (cont.)

Enabling the comfort function

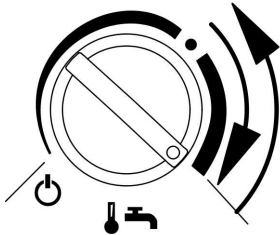

Turn the rotary selector  briefly and fully clockwise (shorter than 3 s), and then turn it anti-clockwise. The Display will then show "COMFORT".

Disabling the comfort function

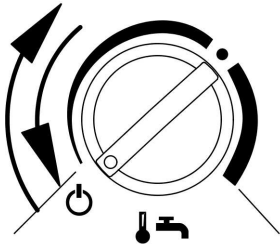

Turn the rotary selector  briefly and fully anti-clockwise (shorter than 3 s), and then turn it clockwise. The display will then show "ECO".

Adjusting the boiler water temperature

The boiler water temperature must be set at an adequate level to satisfy the requirements of the heating system.

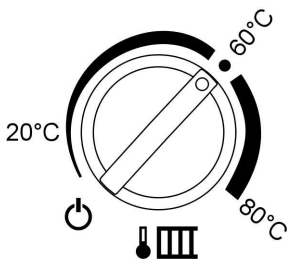

Selecting the boiler water temperature:
Set rotary selector  to the desired DHW temperature.

Installation

Commissioning and testing (cont.)

Final checks

1. If a time switch has been built into the control unit:
Set required activation periods as per the time switch operating instructions.
2. Fill in the relevant details for the installation in the benchmark log-book supplied in the instructions pack and affix the self adhesive bar code strip from the outside of the boiler packaging to this logbook.



Time switch operating instructions

User 's instructions

Upon completion of commissioning and testing, hand the appliance over to the user, with reference to the following.

- Give the users instructions to the responsible person for the property and emphasise their responsibilities under the current edition of the Gas Safety (Installation and Use) Regulations.
- Explain and demonstrate the lighting and shutdown procedures.
- Advise the householder on the efficient use of the system, including the use and adjustment of all system controls for both DHW and CH.
- Advise the user of the precautions necessary to prevent damage to the system and to the building in the event of the system remaining inoperative during frost conditions.
- Explain the function of the boiler safety controls and how to reset them. Emphasise that if cut-out persists, the boiler should be turned off and the installer or service engineer consulted.
- Stress the importance of an annual service by a registered heating engineer.

Routine Servicing Instructions

To ensure continued efficient operation of the appliance, it is recommended that it is checked and serviced as necessary at regular intervals. The frequency of servicing will depend upon the particular installation conditions and usage but in general once a year should be adequate. It is the law that any service work must be carried out by a competent CORGI registered person.

The boiler incorporates a flue sampling point in front of the flue outlet. The flue gases can be analysed if required. The push fit cap may be removed and a sample tube fitted. The push fit cap must be replaced after use. The flue gas sample will enable the service engineer to judge whether any major action is required. Before commencing any service operation, isolate the mains electrical supply and turn off the gas supply at the main service cock.

Removing front panel

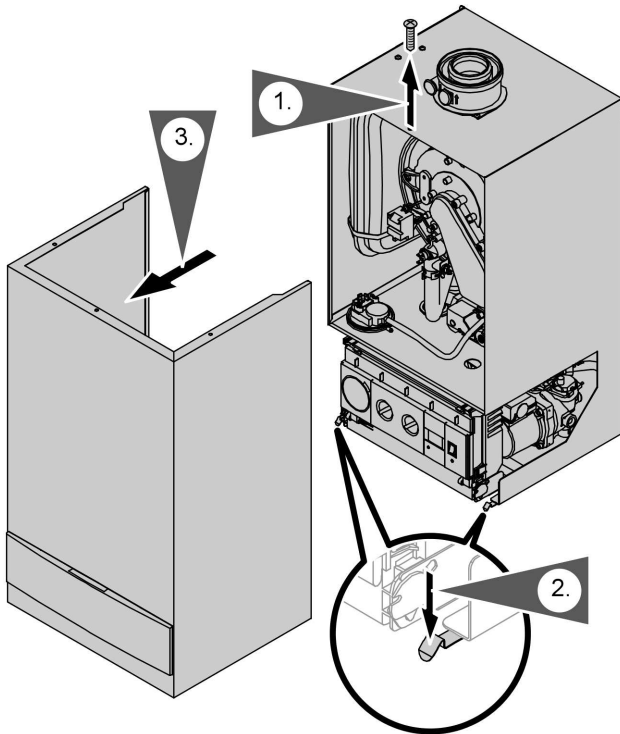

Routine Servicing Instructions (cont.)

1. Remove the screw at the top of the boiler.
2. Press down the springs on the underside of the boiler and remove the front panel.
3. Lift the front panel from the wall mounting frame.

Burner removal

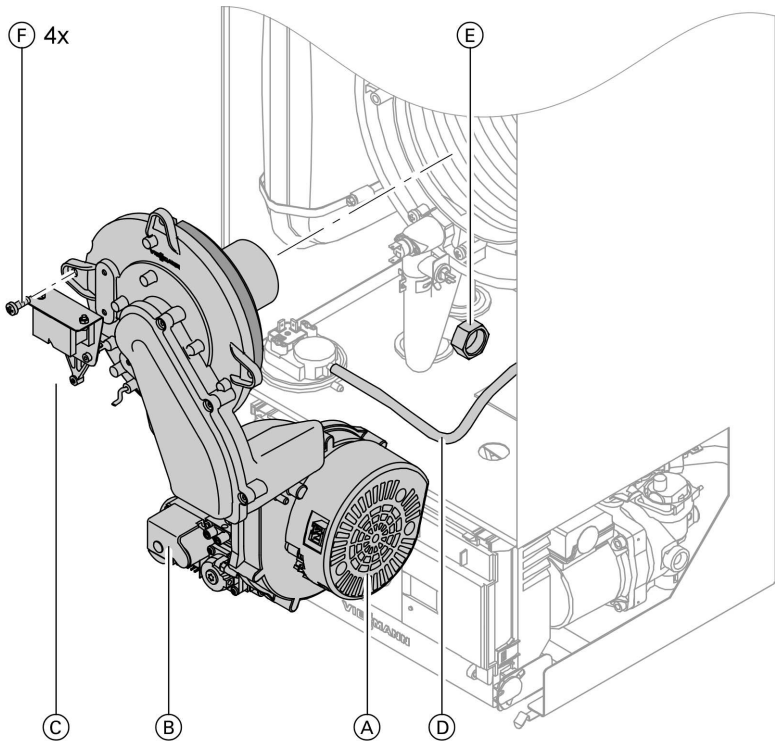

1. Switch OFF the mains power.
2. Close the gas shut-off valve and safeguard against reopening.
3. Pull electrical cables from fan motor (A), gas train (B), and ignition unit (E).
4. Remove connection hose from air pressure switch (D).



Routine Servicing Instructions (cont.)

- 5. Release gas connection pipe (E).
- 6. Release four screws (F) and remove the burner.

! **Please note**
To prevent damage, never rest the burner on the gauze assembly.

Check the burner gasket and burner gauze assembly for damage.

Check the burner gasket (A) for damage and replace if necessary.

Replace the burner gauze assembly if it is damaged.

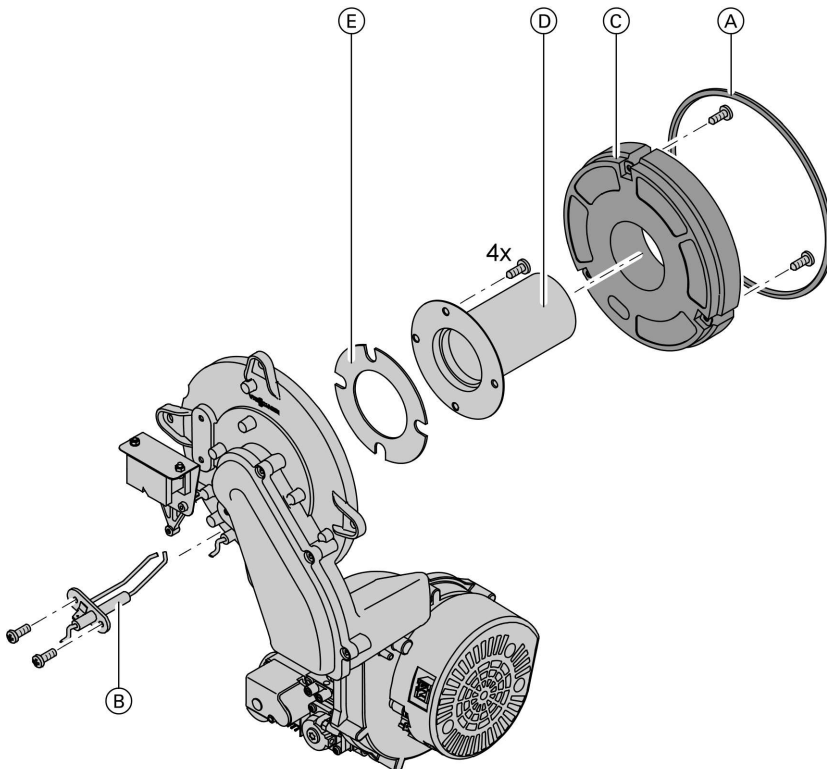

Service



Routine Servicing Instructions (cont.)

1. Remove electrode (B).
2. Release the three Torx screws, and remove thermal insulating ring (C).
3. Release the four Torx screws, and remove burner gauze assembly (D) with its gasket (E).
4. Insert and secure a new burner gauze assembly (D) with a new gasket (E).
Torque: 3.5 Nm.approx.
5. Refit the thermal insulation ring (C).
6. Refit the electrode (B).
Torque: 2.5 Nm.approx.

Checking and adjusting the ignition and ionisation electrodes

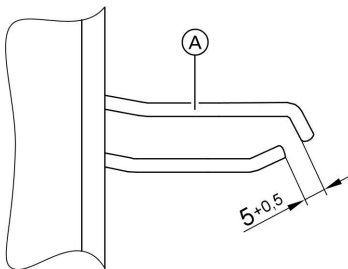
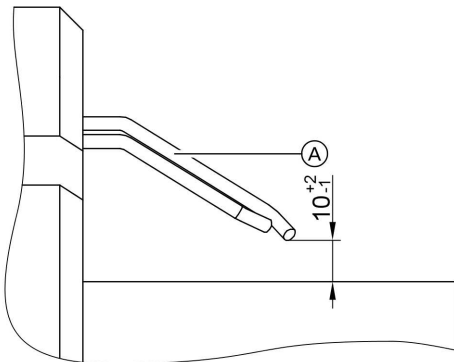

(A) Ignition and ionisation electrode

1. Check the electrode for wear and contamination.
2. Clean the electrode with a small brush (not with a wire brush) or emery paper.



Routine Servicing Instructions (cont.)

3. Check all clearances. If the gaps are not as specified or the electrode is damaged, replace and align the electrode together with new gaskets. Tighten the electrode fixing screws. (2.5 Nm approx.).

Cleaning the heating surfaces

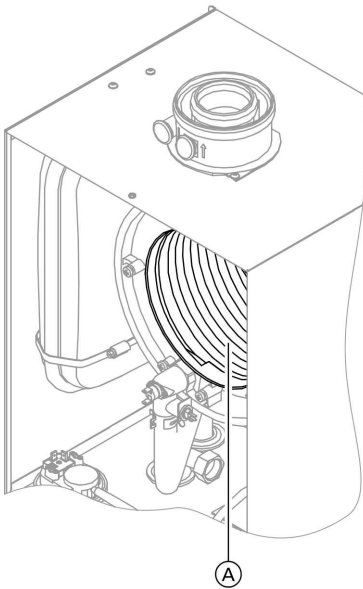

If required, clean heating surfaces (A) with a brush or flush with water.

- ! **Please note**
Scratches on parts which are in contact with flue gases can lead to corrosion.
Only use plastic brushes and NOT wire brushes.

Routine Servicing Instructions (cont.)

Checking the condensate drain and cleaning the siphon

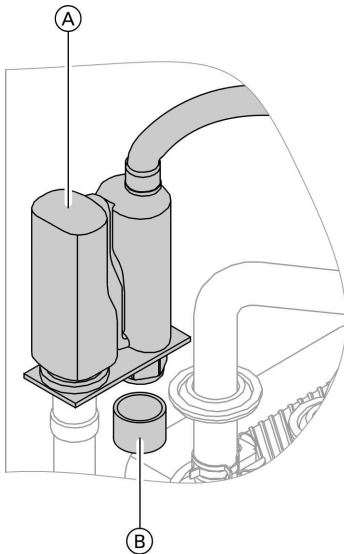

1. Check at the siphon, that the condensate can freely drain.
2. Place an appropriate container under the siphon (A).
3. Remove the locking cap (B) and drain the siphon content.
4. Replace the locking cap (B).
5. Fill the siphon (A) with water by pouring about 0.3l of water into the combustion chamber.

Routine Servicing Instructions (cont.)

Burner installation

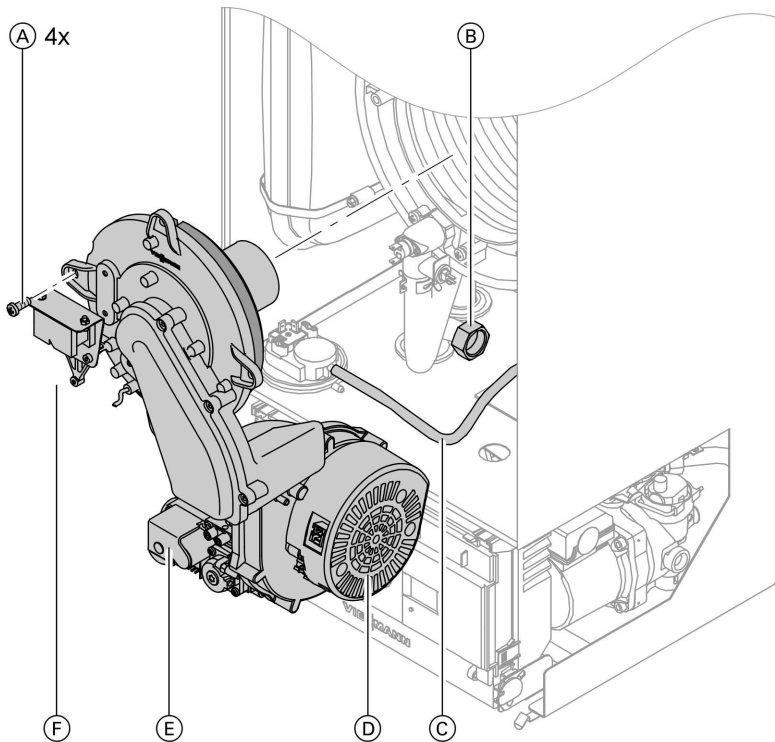

1. Install the burner and torque screws (A) diagonally. (4 Nm. approx.)
2. Insert new gasket and tighten the fittings on the gas connection pipe (B)
3. Insert air pressure switch connection pipe (C) onto the gas valve "OUT" connector.
4. Replace electrical cables from fan motor (D), gas valve (E), and ignition unit (E).
5. Open gas shut-off valve and switch on the mains.

Routine Servicing Instructions (cont.)

6. Check the gas connections for soundness.



Danger

Escaping gas leads to a risk of explosion.
Check all fittings for soundness.

Check primary and secondary connections for leaks

Checking diaphragm expansion vessel and system pressure

Note

Carry out this test on a cold system.

1. Empty the system until a pressure of "0" is displayed.

Note

To view the operating pressure, turn rotary selectors "↓ III" and "↓ ↻" counter clockwise to the end stop.

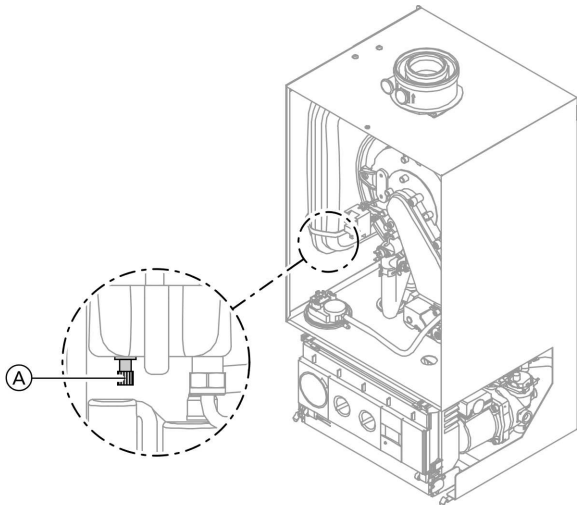

Routine Servicing Instructions (cont.)

2. Check the inlet pressure of the diaphragm expansion vessel at the test nipple (A).
3. If the inlet pressure of the diaphragm expansion vessel is lower than the static system pressure, top up with nitrogen until the inlet pressure is raised by 0.1 to 0.2 bar.
4. Top up your heating system with water and vent until the filling pressure of a cool system is 0.2 bar higher than the inlet pressure of the diaphragm expansion vessel.
Max. operating pressure: 3 bar
Min. operating pressure: 1.0 bar

Topping up heating water via an external filling loop

1. Turn both rotary selectors "🔧" and "🔧" counter clockwise to the end stop.
The display shows the operating pressure.
2. Top up heating water via the external filling loop, until the required operating pressure has been reached.
3. Return both rotary selectors "🔧" and "🔧" to their original positions.

Checking function of all safety valves

Checking tightness of electrical connections

Checking static and supply pressure

See page 51.

Routine Servicing Instructions (cont.)

Front panel installation

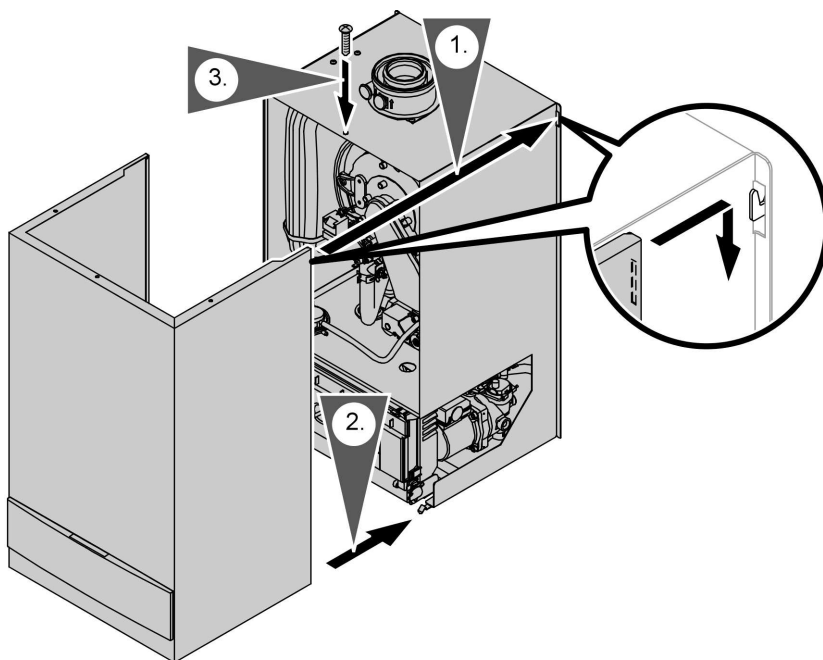

1. Hang the front panel to the wall mounting frame by the appropriate hook.

2. Press down the front panel at the bottom.

3. Insert the screw at the top of the boiler.

Note

The outer case forms a seal with the combustion box: It must therefore be securely fitted with the screw provided.

Start-up the boiler

1. Open gas shut-off valve and switch on mains voltage.

2. Check the operation of the appliance in both central heating and DHW modes.

Routine Servicing Instructions (cont.)

Checking all gas equipment for soundness at operating pressure



Danger

Escaping gas leads to a risk of explosion.

Check gas equipment for soundness.

Final checks

1. Check that the flue terminal is in good condition and clear of any obstructions.
2. Return all appliance and external controls (if fitted) to their original settings.

Fault finding

General

Note

It is the law that any service work must be carried out by a competent CORGI registered fitter.

Before looking for a fault condition, check that:

- The mains electrical supply is turned on.
- The clock and / or room thermostat (if fitted) are calling for heat (CH 'faults' only).
- The gas service cock is open.
- The DHW (Combi only) and CH isolation cocks are open.
- The system is at design pressure.

Before attempting any electrical fault finding, always conduct the preliminary electrical system safety checks. On completion of any service or fault finding operation involving making or breaking electrical connections always check for earth continuity, polarity and resistance to earth.

Function sequence and possible faults

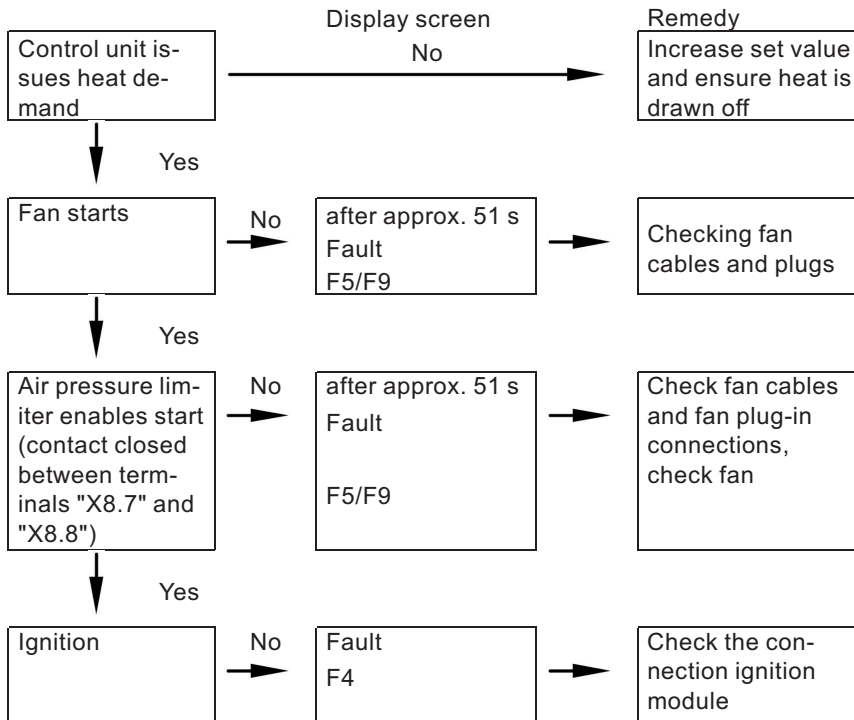

Fault finding (cont.)

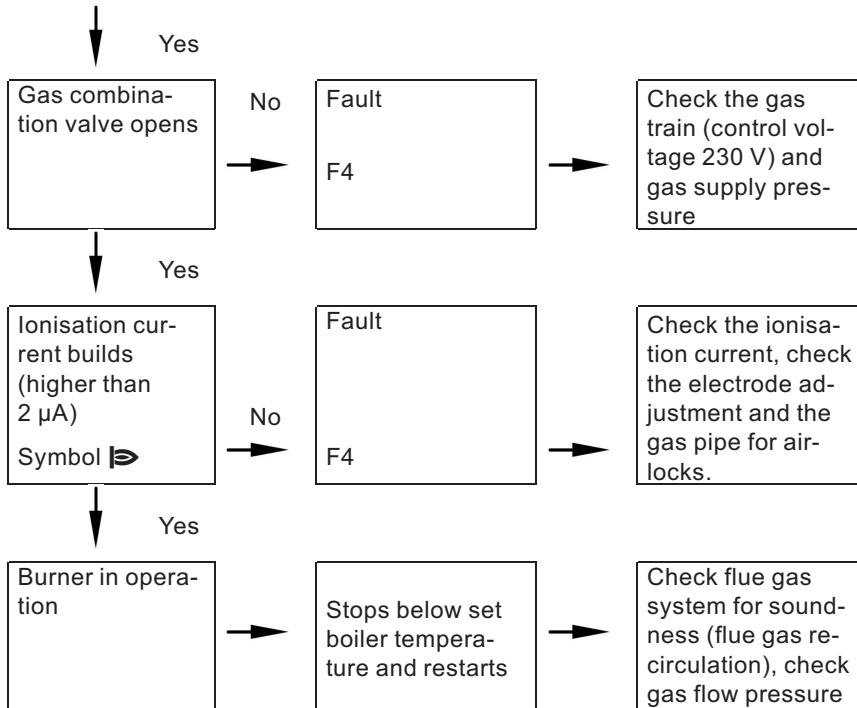

Fault messages in the display

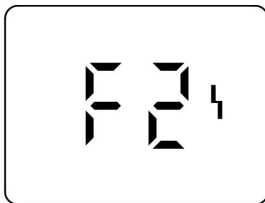

Faults are indicated by a flashing fault code with fault symbol "f" and the reset key is illuminated. For fault code explanations see the following table.

Fault finding (cont.)

Display fault code	System characteristics	Cause	Measures
0b	Burner blocked	Flow of water to low. Air in heat exchanger. Flow switch faulty.	Check the circulation pump. Vent the heating system. Check the interconnecting cable.
0C	Burner blocked	Voltage to low.	Contact the electricity supplier.
30	Burner blocked	Boiler temperature sensor shorted out	Check the boiler temperature sensor (see page 72).
38	Burner blocked	Boiler temperature sensor lead break	Check the boiler temperature sensor (see page 72).
51	No DHW heating	Draw off temperature sensor short circuit	Check sensors (see page 74).
59	No DHW heating	Draw off temperature sensor short circuit	Check sensors (see page 74).
b1	Control mode	Communication fault – programming unit (internal)	Check connections and replace the programming unit, if necessary.
b5	Control mode	Internal fault	Replace control unit.
E4	Burner blocked	Fault – supply voltage	Replace control unit.
E5	Burner blocked	Internal fault	Check the ionisation electrode and leads. Press "Reset".
E6	Burner blocked	Water pressure too low	Top up water (see page 63).
F0	Burner blocked	Internal fault	Replace control unit.
F2	Burner in fault state	Temperature limiter has responded	Check the heating system water level. Check the circulation pump. Vent the heating system. Check the temperature limiter and leads. Press "Reset".



Fault finding (cont.)

Display fault code	System characteristics	Cause	Measures
F3	Burner in fault state	The flame signal is already present at burner start	Check the ionisation electrode and leads. Press "Reset".
F4	Burner in fault state	No flame signal is present	Check the ionisation electrode and leads, measure the ionisation current, check the gas pressure, check the gas combination valve, ignition, ignition module and condensate drain. Press "Reset".
F5	Burner blocked	Air pressure switch faulty	Check the air pressure switch and the interconnecting cable.
F7	Burner blocked	Faulty water pressure sensor	Check the water pressure sensor and the interconnecting cable.
F8	Burner in fault state	Fuel valve closes too late	Check gas combination valve. Check both control paths. Press "Reset".
F9	Burner in fault state	Fan speed too low at burner start	Check the fan, check the fan cables and supply, check the fan control. Press "Reset".
FA	Burner in fault state	Fan not at standstill	Check the fan, check the fan cables, check the fan control. Press "Reset".
Fd	Burner blocked	Burner control unit fault	Check the ignition electrodes and leads. Check whether a strong interference (EMC) field exists near the equipment. Press "Reset". If the fault is not removed, replace the control unit.

5862 881 GB

Service



Fault finding (cont.)

Display fault code	System characteristics	Cause	Measures
FE	Burner blocked	Faulty main PCB	Switch OFF the control unit, if the equipment will not restart.

Repairs

Removing front panel

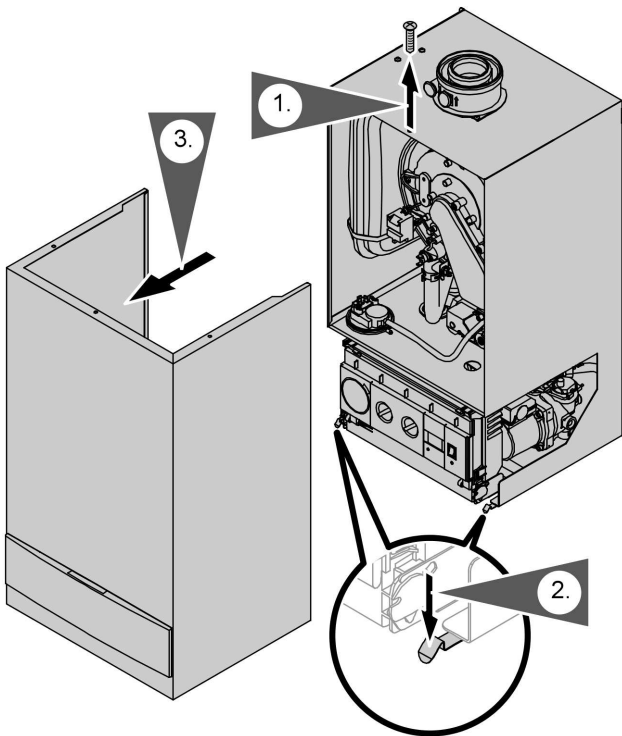

1. Remove the screw at the top of the boiler.

2. Press down the springs on the underside of the boiler and remove the front panel.

Repairs (cont.)

3. Lift the front panel from the wall mounting frame.

Drain boiler on the primary side

Note

For certain repairs the boiler must be drained on the primary side.

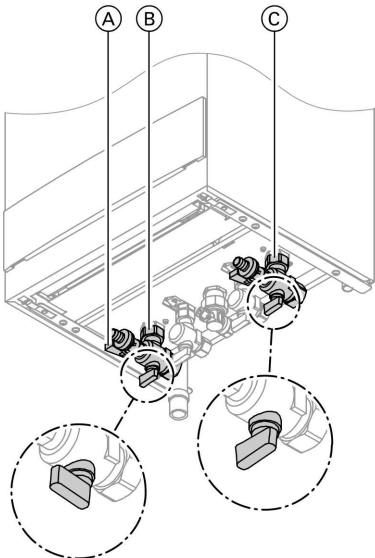

1. Connect the drain hose to valve (A) and connect with a drain outlet.
2. Turn toggle on the shut-off valve (B) to the front.
3. Turn toggle on the shut-off valve (C) to the front.
4. Turn toggle on the valve (A) to the front and drain the boiler if necessary. Turn toggle back down again.

Note

Residual water left in the boiler.

5. Turn toggle on the shut-off valve (B) to the front.

Note

Filling up on the primary side see page 47.

Repairs (cont.)

Boiler temperature sensor

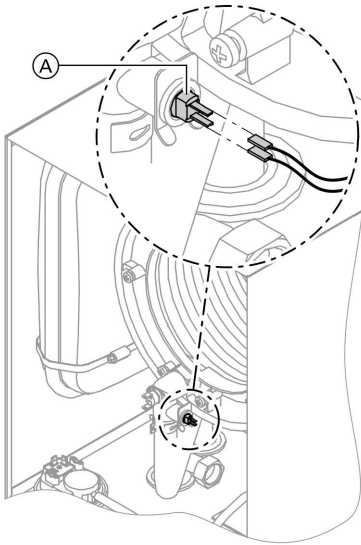

1. Pull the leads from boiler temperature sensor **A** and measure the resistance.

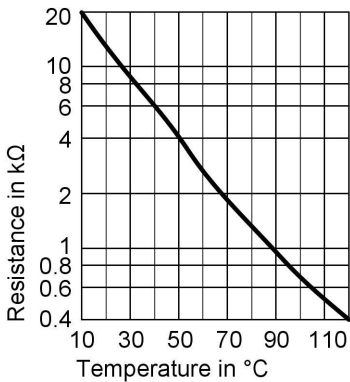

2. Check the sensor resistance and compare actual values with the curve.
3. In case of severe deviation, drain boiler on the primary side (see page 71) and replace the sensor.



Danger

The boiler temperature sensor is immersed in the heating water (risk of scalding). Drain the boiler before replacing the sensor.

Repairs (cont.)

Check the temperature limiter

If the burner control unit cannot be reset after a fault shutdown, although the boiler water temperature is below approx. 75 °C, check the temperature limiter.

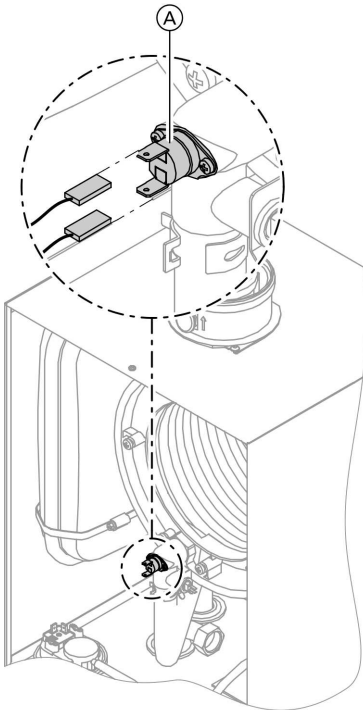

1. Pull the leads from temperature limiter (A).
2. Check the continuity of the temperature limiter with a multimeter.
3. Remove faulty temperature limiter.
4. Coat the replacement temperature limiter with heat conducting paste and install.
5. To reset press "Reset" key on the control unit.

Repairs (cont.)

Check the DHW temperature sensor (only for gas combination devices)

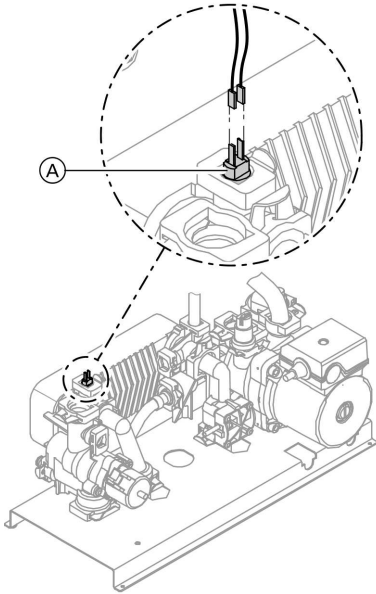

1. Pull the leads from outlet temperature sensor (A)
2. Check the sensor resistance and compare actual values with the curve.

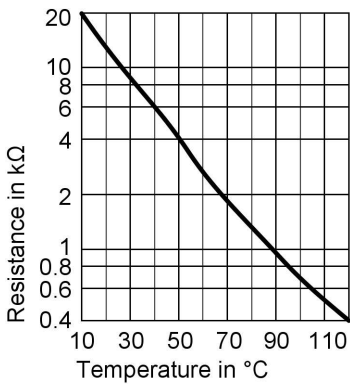

3. Replace the sensor in case of severe deviation.

Note

Water can leak out when replacing the outlet sensor. Close the cold water shut-off valve. Drain DHW pipe and plate-type heat exchanger (secondary side).

Repairs (cont.)

Replacing flow limiter

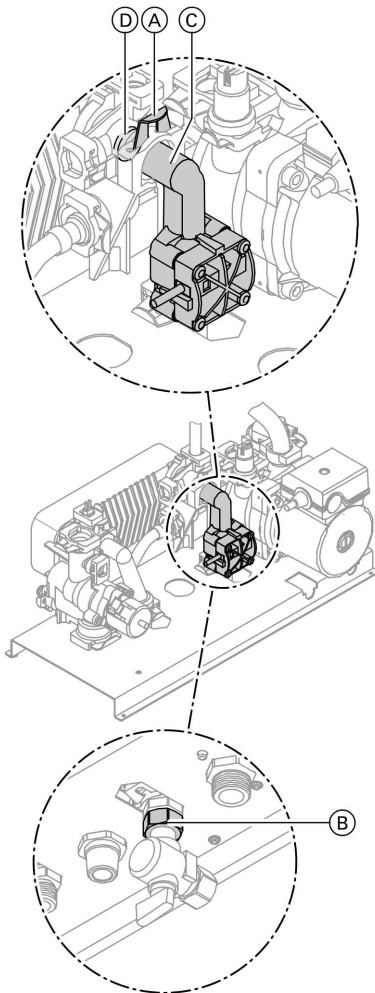

1. Switch OFF the mains power.
2. Close the gas shut-off valve and safeguard against reopening.
3. Drain the boiler from the secondary side.
4. Pivot the control unit downwards.
5. Release the ties (A) and screws (B).
6. Remove the flow switch (C) connector.
7. Replace flow limiter (D).
8. Refit the flow switch (C) connector.

Repairs (cont.)

Checking plate-type heat exchanger

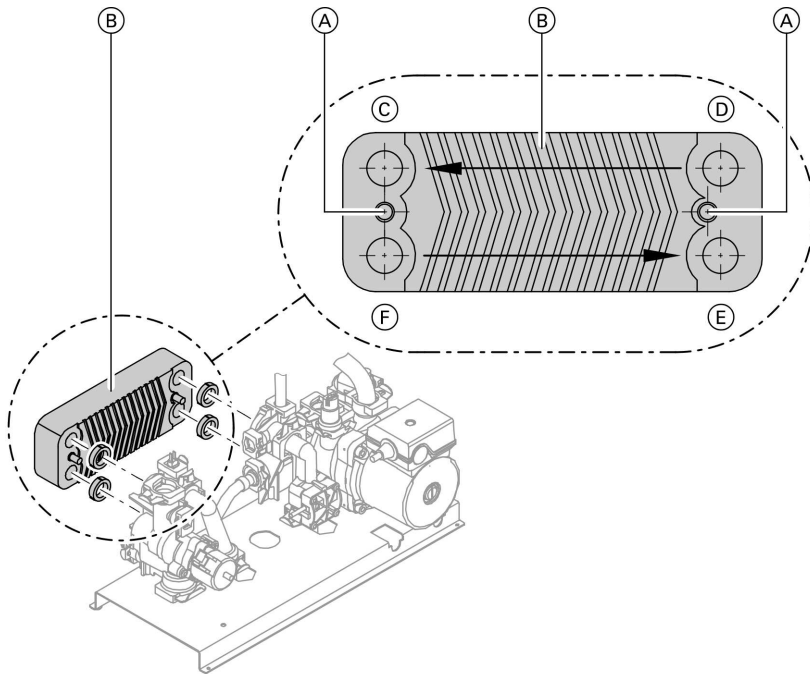

- Ⓒ DHW outlet
- Ⓓ Cold water

- Ⓔ Heating water return
- Ⓕ Heating water flow

1. Switch OFF the mains power.
2. Close the gas shut-off valve and safeguard against reopening.
3. Shut off and drain the boiler on the primary and the secondary side. Draining on the primary side (see page 71).
4. Flip down control unit.

5. Remove two screws Ⓐ at the plate-type heat exchanger and Ⓑ remove.

Note

During removal, small amounts of water may trickle out and escape from the removed plate-type heat exchanger.



Repairs (cont.)

6. Check the secondary side for contamination and, if necessary, clean or replace the plate-type heat exchanger.
7. Check the primary side for contamination and, if necessary, clean or replace the plate-type heat exchanger.
8. Install in reverse order using new gaskets.

Note

Ensure that fixing holes and seals are aligned. Install the heat plate exchanger the correct way round.

Checking the fuse

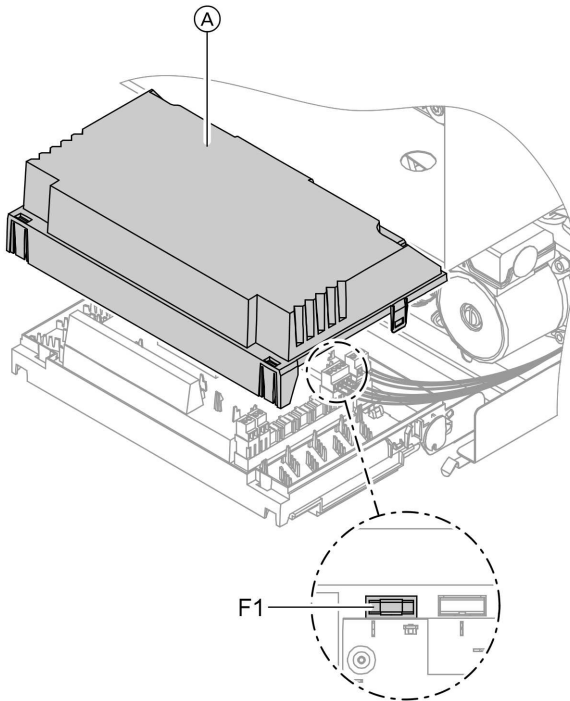

1. Switch OFF the mains power.
2. Flip down control unit.
3. Remove cover (A).
4. Check fuse F1.

5862 881 GB

Connection and wiring diagrams – combi boiler

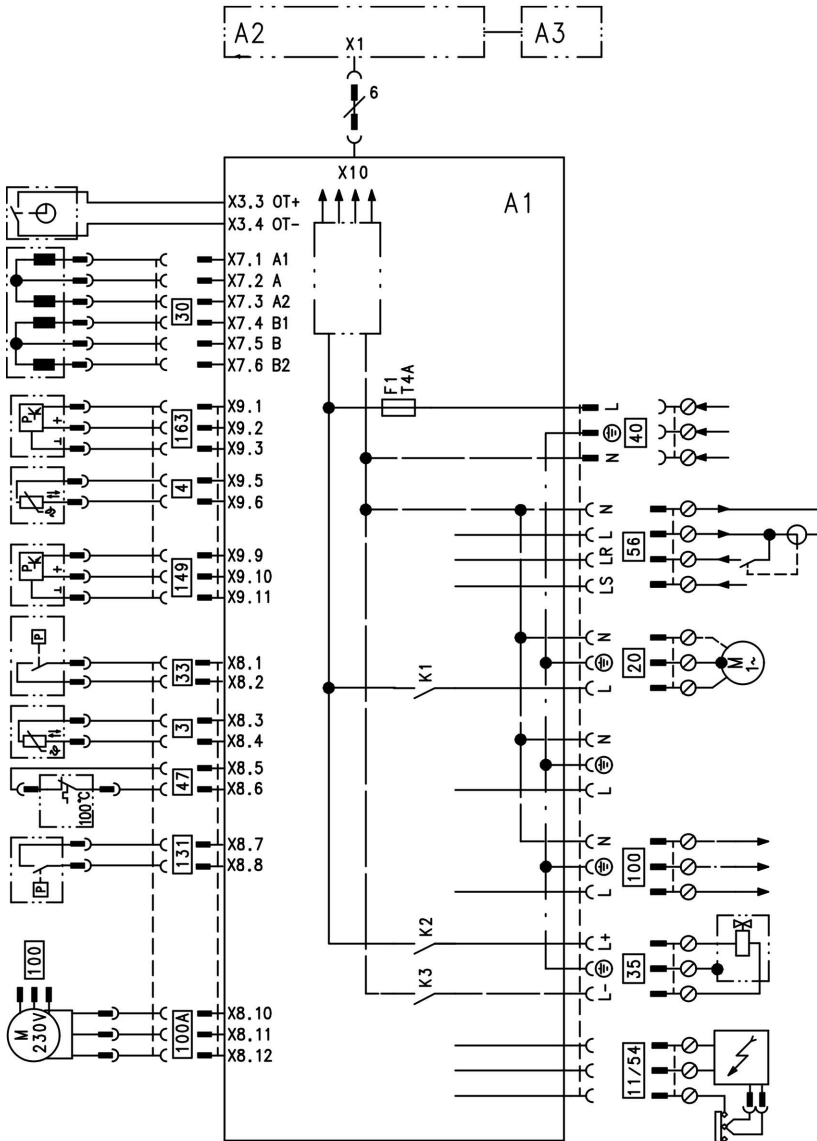

A1 Main PCB
 A2 Programming unit

A3 Time switch

Connection and wiring diagrams – combi boiler (cont.)

Ⓐ	Alternative (remove jumper when connecting)	40	Mains input 230V~/50Hz
3	Boiler temperature sensor	47	Temperature limiter
4	DHW outlet sensor	56	Mains connection accessories/ room temperature control
20	Circulation pump 230V~	100A	Fan
30	Step motor diverter valve	131	Air pressure switch
33	Flow switch (Heating water)	149	Flow switch (DHW)
35	Gas solenoid valve	163	Water pressure sensor

Connection and wiring diagram - system boiler

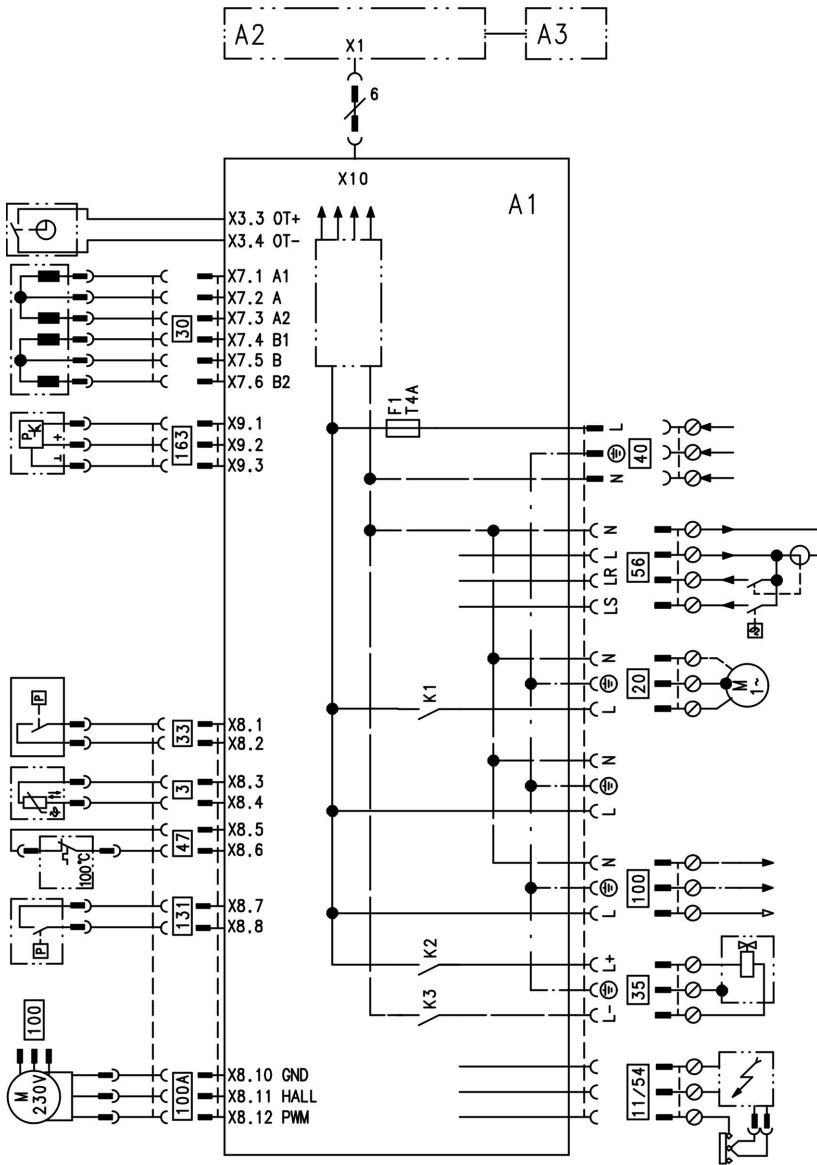

A1 Main PCB
 A2 Programming unit

A3 Time switch

Connection and wiring diagram - system boiler (cont.)

- (A) Alternative (remove jumper when connecting)
- 3 Boiler temperature sensor
- 20 Circulation pump 230V~
- 30 Step motor diverter valve
- 33 Flow switch (heating water)
- 35 Gas solenoid valve
- 40 Mains input 230V~/50Hz
- 47 Temperature limiter
- 56 Mains connection accessories/
room temperature control/DHW
cylinder control
- 100A Fan
- 131 Air pressure switch
- 163 Water pressure sensor

Parts lists

Spare parts information

Quote the type and serial no. (see data plate) and the item no. of the required part (as per this parts list). Obtain standard parts from your local supplier.

- 001 Thermocouple
- 002 Temperature sensor
- 003 Pressure switch
- 004 Control cable
- 005 Diaphragm expansion vessel connecting cable
- 006 Diaphragm expansion vessel
- 007 Boiler connection plug
- 008 Boiler adaptor
- 009 Flue gas gaskets (set)
- 010 Heat exchanger
- 011 Insulating block
- 012 Heat exchanger mounting (set)
- 013 Condensate hose
- 014 Siphon
- 015 Condensate pipe
- 016 Gas supply pipe
- 017 Heating water flow connection elbow
- 018 Heating water return connection elbow
- 019 Heating water flow connection pipe
- 020 Heating water return connection pipe
- 021 Plate-type heat exchanger*¹
- 022 Gasket set – plate-type heat exchanger*¹
- 026 Quick air vent valve cartridge
- 027 Safety valve
- 028 Water pressure sensor
- 029 Flow switch (DHW)*¹
- 030 Step motor cartridge
- 031 Circulation pump
- 032 Bypass with overflow valve
- 033 Grommets
- 034 Gaskets (set)
- 035 Spring clips (set)
- 036 Flow limiter
- 037 Hydraulic
- 038 Expansion pipe
- 040 Lip seal Ø 60 mm
- 041 Ventilation seal Ø 100 mm
- 050 Burner gasket
- 051 Insulation ring
- 052 Burner gauze assembly
- 053 Burner gauze assembly gasket
- 058 Mixture damper
- 059 Radial fan
- 060 Venturi top
- 061 Gas train
- 062 Burner door
- 063 Ignition unit
- 065 Flow switch (Heating water)
- 080 Control unit
- 081 Cover – wiring chamber
- 200 Front panel
- 201 Spring tie
- 202 Cover flap
- 203 Domestic water fittings (set)*¹
- 204 Heating water fittings (set)
- 205 Corner gas tap
- 206 Elbow with locking ring fittings Ø 22 mm (set)*²

Wearing parts

- 054 Ignition and ionisation electrode

Parts not shown

- 039 Installation and service instructions
- 090 Cable harness X8
- 091 Cable harness X9
- 092 Cable harness 100/35/54
- 093 Step motor connecting cable

*¹Only for serial no. 7247 427 and 7247 428

*²Only for serial no. 7247 426



Parts lists (cont.)

- 094 Mains power switch cable harness
- 095 Gas valve connecting cable 35
- 096 Ignition transformer/ionisation connecting cable
- 300 Touch-up spray paint, Vitowhite
- 301 Touch-up paint stick, Vitowhite
- Ⓐ Data plate

Parts lists (cont.)

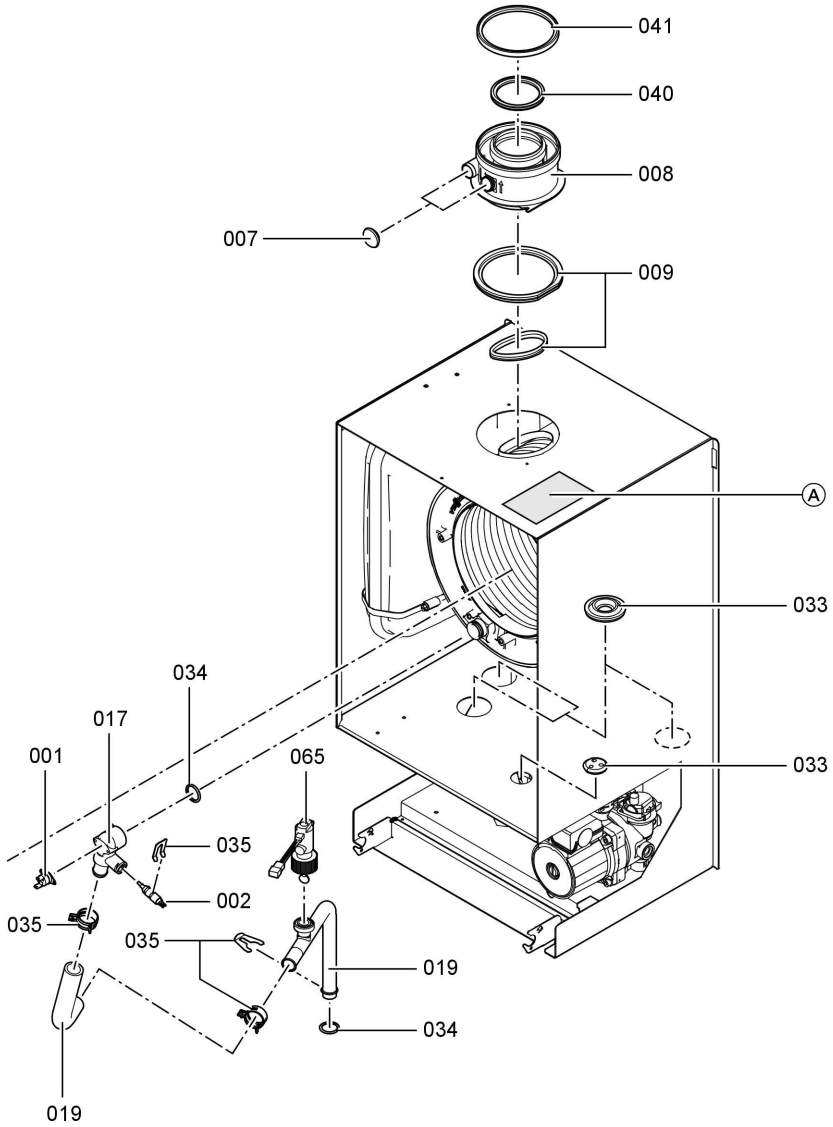

Parts lists

Parts lists (cont.)

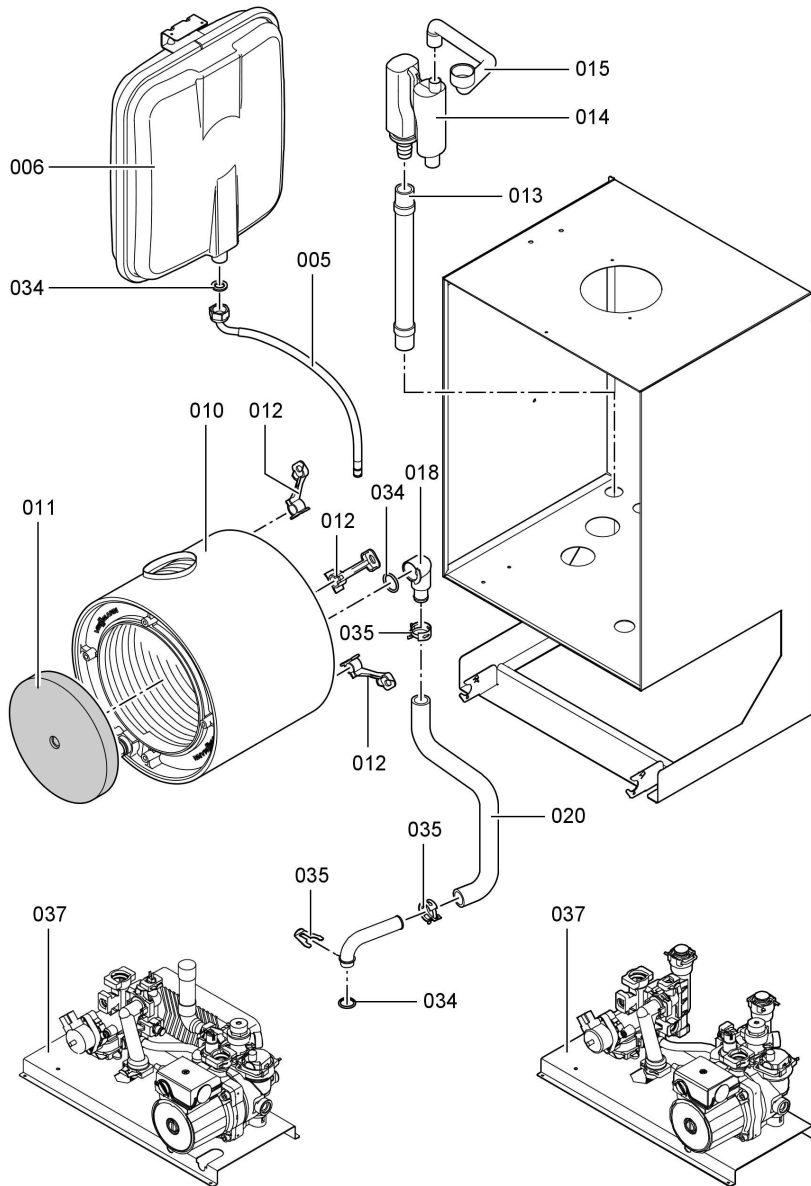

Parts lists (cont.)

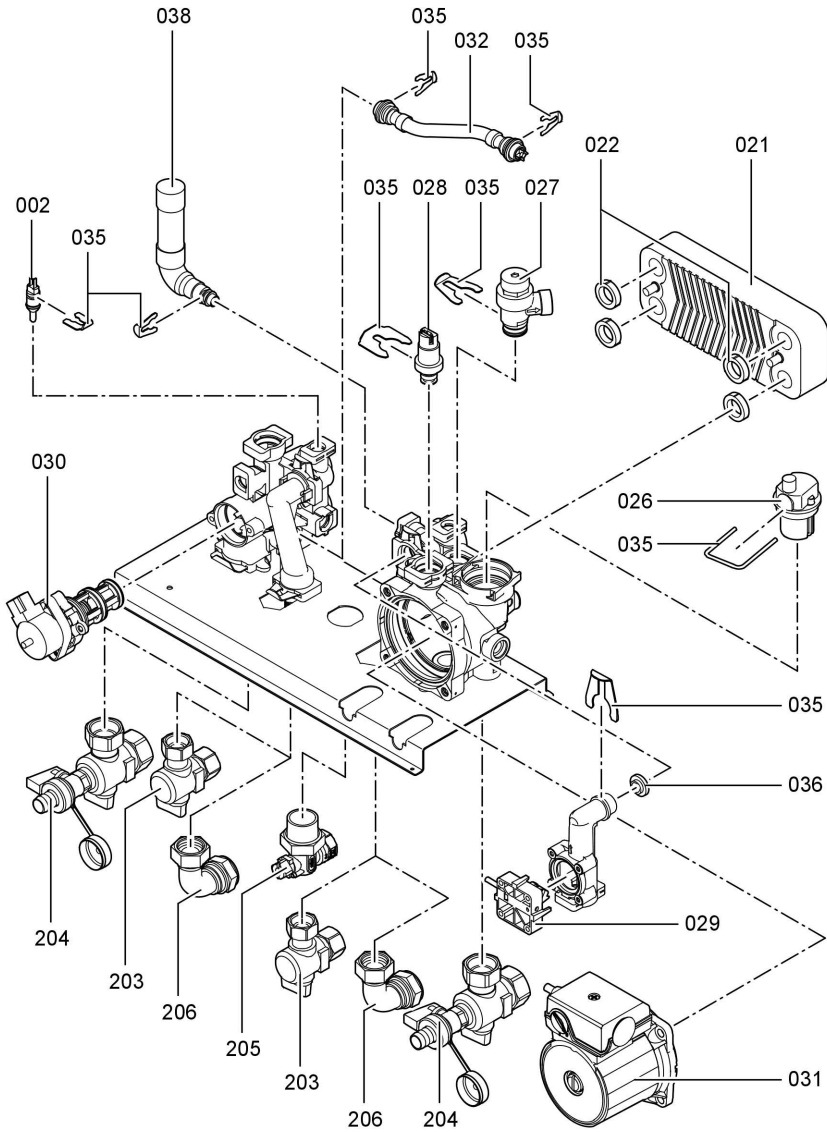

Commissioning/service reports



BENCHMARK No. | | | | | | | | | |

GAS BOILER COMMISSIONING CHECKLIST

BOILER SERIAL No. _____ NOTIFICATION No. _____

CONTROLS To comply with the *Building Regulations*, each section must have a tick in one or other of the boxes

TIME & TEMPERATURE CONTROL TO HEATING	ROOM T/STAT & PROGRAMMER/TIMER	<input type="checkbox"/>	PROGRAMMABLE ROOM/STAT	<input type="checkbox"/>
TIME & TEMPERATURE CONTROL TO HOT WATER	CYLINDER T/STAT & PROGRAMMER/TIMER	<input type="checkbox"/>	COMBI BOILER	<input type="checkbox"/>
HEATING ZONE VALVES	FITTED	<input type="checkbox"/>	NOT REQUIRED	<input type="checkbox"/>
HOT WATER ZONE VALVES	FITTED	<input type="checkbox"/>	NOT REQUIRED	<input type="checkbox"/>
THERMOSTATIC RADIATOR VALVES	FITTED	<input type="checkbox"/>		
AUTOMATIC BYPASS TO SYSTEM	FITTED	<input type="checkbox"/>	NOT REQUIRED	<input type="checkbox"/>

FOR ALL BOILERS CONFIRM THE FOLLOWING

THE SYSTEM HAS BEEN FLUSHED IN ACCORDANCE WITH THE BOILER MANUFACTURER'S INSTRUCTIONS?

THE SYSTEM CLEANER USED _____

THE INHIBITOR USED _____

FOR THE CENTRAL HEATING MODE, MEASURE & RECORD

GAS RATE _____ m³/hr _____ ft³/hr

BURNER OPERATING PRESSURE (IF APPLICABLE) N/A _____ mbar

CENTRAL HEATING FLOW TEMPERATURE _____ °C

CENTRAL HEATING RETURN TEMPERATURE _____ °C

Commissioning/service reports (cont.)

FOR COMBINATION BOILERS ONLY

HAS A WATER SCALE REDUCER BEEN FITTED? YES NO
 WHAT TYPE OF SCALE REDUCER HAS BEEN FITTED? _____

FOR THE DOMESTIC HOT WATER MODE, MEASURE & RECORD

GAS RATE _____ m³/hr _____ ft³/hr
 MAXIMUM BURNER OPERATING PRESSURE (IF APPLICABLE) N/A _____ mbar
 COLD WATER INLET TEMPERATURE _____ °C
 HOT WATER OUTLET TEMPERATURE _____ °C
 WATER FLOW RATE _____ lts/min

FOR CONDENSING BOILERS ONLY CONFIRM THE FOLLOWING

THE CONDENSATE DRAIN HAS BEEN INSTALLED IN ACCORDANCE WITH THE MANUFACTURER'S INSTRUCTIONS? YES

FOR ALL INSTALLATIONS CONFIRM THE FOLLOWING

THE HEATING AND HOT WATER SYSTEM COMPLIES WITH CURRENT BUILDING REGULATIONS
 THE APPLIANCE AND ASSOCIATED EQUIPMENT HAS BEEN INSTALLED AND COMMISSIONED IN ACCORDANCE WITH THE MANUFACTURER'S INSTRUCTIONS
 IF REQUIRED BY THE MANUFACTURER, HAVE YOU RECORDED A CO/CO₂ RATIO READING? N/A YES CO/CO₂ RATIO _____
 THE OPERATION OF THE APPLIANCE AND SYSTEM CONTROLS HAVE BEEN DEMONSTRATED TO THE CUSTOMER
 THE MANUFACTURER'S LITERATURE HAS BEEN LEFT WITH THE CUSTOMER

COMMISSIONING ENG'S NAME PRINT _____ CORGI ID No. _____
 SIGN _____ DATE _____



Commissioning/service reports (cont.)

SERVICE INTERVAL RECORD

It is recommended that your heating system is serviced regularly and that you complete the appropriate Service Interval Record Below.

Service Provider. Before completing the appropriate Service Interval Record below, please ensure you have carried out the service as described in the boiler manufacturer's instructions. Always use the manufacturer's specified spare part when replacing all controls

SERVICE 1 DATE

ENGINEER NAME

COMPANY NAME

TEL No.

CORGI ID CARD SERIAL No.

COMMENTS

SIGNATURE

SERVICE 2 DATE

ENGINEER NAME

COMPANY NAME

TEL No.

CORGI ID CARD SERIAL No.

COMMENTS

SIGNATURE

SERVICE 3 DATE

ENGINEER NAME

COMPANY NAME

TEL No.

CORGI ID CARD SERIAL No.

COMMENTS

SIGNATURE

SERVICE 4 DATE

ENGINEER NAME

COMPANY NAME

TEL No.

CORGI ID CARD SERIAL No.

COMMENTS

SIGNATURE

Commissioning/service reports (cont.)

SERVICE 6 DATE _____
ENGINEER NAME _____
COMPANY NAME _____
TEL No. _____
CORG ID CARD SERIAL No. _____
COMMENTS _____
SIGNATURE _____

SERVICE 8 DATE _____
ENGINEER NAME _____
COMPANY NAME _____
TEL No. _____
CORG ID CARD SERIAL No. _____
COMMENTS _____
SIGNATURE _____

SERVICE 10 DATE _____
ENGINEER NAME _____
COMPANY NAME _____
TEL No. _____
CORG ID CARD SERIAL No. _____
COMMENTS _____
SIGNATURE _____

SERVICE 5 DATE _____
ENGINEER NAME _____
COMPANY NAME _____
TEL No. _____
CORG ID CARD SERIAL No. _____
COMMENTS _____
SIGNATURE _____

SERVICE 7 DATE _____
ENGINEER NAME _____
COMPANY NAME _____
TEL No. _____
CORG ID CARD SERIAL No. _____
COMMENTS _____
SIGNATURE _____

SERVICE 9 DATE _____
ENGINEER NAME _____
COMPANY NAME _____
TEL No. _____
CORG ID CARD SERIAL No. _____
COMMENTS _____
SIGNATURE _____

Certificates

Declaration of conformity

Declaration of conformity for Vitodens 100

We, Viessmann Werke GmbH & Co KG, D-35107 Allendorf, declare as sole responsible body, that the product

Vitodens 100

conforms to the following standards:

DIN 4702-6

EN 297

EN 483

EN 625

EN 677

EN 50,165

EN 55,014

EN 60,335

EN 61 000-3-2

EN 61 000-3-3

This product is designated in accordance with the following directives:

90/ 396/EEC

89/ 336/EEC

73/ 23/EEC

92/ 42/EEC

as follows:

CE-0085

This product complies with the requirements of the Efficiency Directive (92/42/EEC) for condensing boilers.

Allendorf, 05.10.06

Viessmann Werke GmbH&Co KG



pp. Manfred Sommer

Keyword index

A		H	
additives	46	Horizontal Flue System	9
Appliance description	5	I	
Appliance Dimensions	7	Ignition electrode	58
B		Installing fittings	32
Boiler Position	16	M	
Boiler temperature sensor	72	Mains connection	41
Boiler temperature sensor	72	Mounting boiler	31
Burner removal	56	O	
C		Outlet temperature sensor	74
Certification details	5	P	
Cleaning the heating surfaces	59	Plate-type heat exchanger	76
Condensate connection	35	R	
Connect room temperature control	41	Removing front panel	31
Connect safety temperature control	41	S	
Connection diagrams	78	Safety chain	73
D		Safety Valve	34
Declaration of conformity	92	Siphon cleaning	60
E		Static pressure	51
Electrical connections	40	System pressure	48
Electricity Supply	27	T	
F		Technical Specification	6
Fault codes	67	Temperature limiter	73
Fault finding	66	Topping up heating water	63
Fault messages	67	U	
Fill the system	48	User 's instructions	54
Final checks	54	V	
Flow limiter	75	Venting	49
Flue outlet	38	Vertical Flue System	10
Function sequence	66	W	
Fuse	77	Wall mounting bracket installation	28
G			
Gas combination valve	51		
Gas connection	32		
Gas Supply	26		
Gas supply pressure	51		
General Information	5		

Keyword index

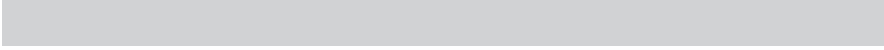





Applicability

Gas fired condensing combi boiler

Type WB1A

8 to 24 kW

from serial no.

7247 428 6 00001

8 to 30 kW

from serial no.

7247 427 6 00001

Viessmann Werke GmbH&Co KG
D-35107 Allendorf
Telephone: +49 6452 70-0
Fax: +49 6452 70-2780
www.viessmann.com

Gas fired condensing boiler

Type WB1A

8 to 24 kW

from serial no.

7247 426 6 00001

Viessmann Limited
Hortonwood 30, Telford
Shropshire, TF1 7YP, GB
Telephone: +44 1952 675000
Fax: +44 1952 675040
E-mail: info-uk@viessmann.com

5862 881 GB Subject to technical modifications.