

Technical guide



Heat pumps with electric drive for central heating and DHW heating in mono mode or dual mode heating systems

VITOCAL 200-G

Type BWC 201.A, BWC-M 201.A

Single stage brine/water heat pump, 400 V~/230 V~.

VITOCAL 300-G

■ Type BW 301.B06 to B17, BWC 301.B06 to B17, BW 301.A21 to A45

Single stage brine/water and water/water heat pump

■ Type BW 301.B06 to B17 + BWS 301.B06 to B17, BW 301.A21 to A45 + BWS 301.A21 to A45

Two-stage brine/water and water/water heat pump

VITOCAL 350-G

■ Type BW 351.B

Single stage brine/water and water/water heat pump

■ Type BW 351.B + BWS 351.B

Two-stage brine/water and water/water heat pump

VITOCAL 222-G Type BWT-M 221.B06 to B10

Compact heat pump with integral DHW cylinder, 230 V~

VITOCAL 333-G Type BWT 331.C06 to C12

Compact heat pump with integral DHW cylinder, 400 V~

Index

1.	Product types designation	6
2.	Vitocal 200-G, type BWC 201.A06 to A17	
	2. 1 Product description	7
	■ Benefits	7
	■ Delivered condition	7
	2. 2 Specification	8
	■ Specification	8
	■ Dimensions	11
	■ Application limits to EN 14511	12
	■ Curves, type BWC	13
	■ Curves, type BWC-M	18
3.	Vitocal 300-G, type BW 301.B06 to B17, BWS 301.B06 to B17, BWC 301.B06 to B17	
	3. 1 Product description	21
	■ Benefits of type BW, BWS	21
	■ Delivered condition, type BW	21
	■ Delivered condition, type BWS	21
	■ Benefits of type BWC	22
	■ Delivered condition, type BWC	22
	3. 2 Specification	23
	■ Specification for brine/water heat pumps	23
	■ Water/water heat pump specification	24
	■ Dimensions, type BW, BWS	26
	■ Dimensions, type BWC	27
	■ Application limits to EN 14511	28
	■ Curves, type BW, BWS	29
	■ Curves, type BWC	34
4.	Vitocal 300-G, type BW 301.A21 to A45, BWS 301.A21 to A45	
	4. 1 Product description	39
	■ Benefits of type BW, BWS	39
	■ Delivered condition, type BW	39
	■ Delivered condition, type BWS	39
	4. 2 Specification	40
	■ Specification for brine/water heat pumps	40
	■ Specification for water/water heat pumps	41
	■ Dimensions for type BW 301.A21 to A45, BWS 301.A21 to A45	42
	■ Application limits to EN 14511	43
	■ Curves, type BW, BWS	44
5.	Vitocal 350-G, type BW 351.B20 to B42, BWS 351.B20 to B42	
	5. 1 Product description	47
	■ Benefits of type BW, BWS	47
	■ Delivered condition, type BW	47
	■ Delivered condition, type BWS	47
	5. 2 Specification	48
	■ Specification for brine/water heat pumps	48
	■ Specification for water/water heat pumps	49
	■ Dimensions, type BW 351.B20 to B42, BWS 351.B20 to B42	50
	■ Application limits	51
	■ Curves, type BW 351.B20 to B42, BWS 351.B20 to B42	52
6.	Vitocal 222-G, type BWT 221.B06 to B10	
	6. 1 Product description	56
	■ Benefits	56
	■ Delivered condition	57
	6. 2 Specification	58
	■ Specification	58
	■ Dimensions	60
	■ Application limits to EN 14511	62
	■ Curves	62
7.	Vitocal 333-G, type 331.C06 to C12	
	7. 1 Product description	70
	■ Benefits	70
	■ Delivered condition	71
	7. 2 Specification	72
	■ Specification	72
	■ Dimensions	74
	■ Application limits to EN 14511	76
	■ Curves	76
8.	Installation accessories	
	8. 1 Overview	82
	8. 2 Ventilation unit	85

■ Vitovent ventilation units	85
8. 3 Brine circuit (primary circuit)	86
■ Sensor well set, primary circuit	86
■ Brine accessory pack	86
■ Pump set for brine accessory pack	87
■ Brine expansion vessel	90
■ Pressure switch (primary circuit)	91
■ Brine manifold for geothermal probes/geothermal collectors	92
■ Heat transfer medium "Tyfocor"	93
■ Filling station	93
8. 4 Heating circuit (secondary circuit)	94
■ Instantaneous heating water heater	94
■ Ball valve with filter (G 1¼)	94
■ Heat meter	94
■ Heating water buffer cylinder	95
■ Safety equipment block	96
8. 5 Hydraulic connection accessories	97
■ DHW circulation connection set	97
8. 6 Divicon heating circuit distributor	98
■ Design and function	98
■ Circulation pump curves and pressure drop on the heating water side	99
■ Bypass valve	100
■ Wall mounting bracket for individual Divicon	101
■ Manifold	101
■ Wall mounting bracket for manifold	103
8. 7 Accessories for DHW heating with DHW cylinder	103
■ Vitocell 100-V, type CVVA	103
■ EHE immersion heater	108
■ Solar heat exchanger set	109
■ Impressed current anode	109
■ Safety assembly to DIN 1988	109
8. 8 Accessories for DHW heating with cylinder loading system	110
■ Vitocell 100-V, type CVA/CVAA	110
■ Vitocell 100-L, type CVL/CVLA	115
■ Heating lance	118
■ Circulation pump for cylinder loading	118
■ 2-way motorised ball valve (DN 32)	119
8. 9 Accessories for DHW heating with freshwater module/heating water storage	120
■ Vitocell 120-E, type SVW, 600 l	120
■ Vitocell 120-E, type SVW, 950 l	123
■ Immersion heater EHE	123
■ 3-way diverter valve	124
8.10 Accessories for DHW heating with integral DHW cylinder	125
■ Safety assembly to DIN 1988	125
■ Impressed current anode	126
8.11 Installation accessories	126
■ Platform for unfinished floors	126
■ Tundish set	126
■ Transport aid for heat pump module	126
8.12 Cooling	127
■ NC-Box	127
■ Hydraulic connection set, NC-Box	128
■ AC-Box	128
■ Connection accessories for AC-Box	129
■ Contact humidistat 24 V	130
■ Natural cooling extension kit	130
■ 3-way diverter valve (R 1¼)	130
■ Frost stat	130
■ Connection set	130
■ 2-way motorised ball valve (DN 32)	130
■ Contact temperature sensor	130
■ Room temperature sensor for separate cooling circuit	130
8.13 Solar	131
■ Solar collectors	131
■ Solar heat exchanger set (Divicon)	131
■ Solar Divicon, type PS10	132
■ High limit safety cut-out for solar thermal system	134
■ Collector temperature sensor	134
■ Heat transfer medium "Tyfocor LS"	134
9. Design information	
9. 1 Power supply and tariffs	135

■ Application procedure	135
9. 2 Installation requirements	135
■ Siting Vitocal 200-G, 300-G, 350-G	135
■ Siting the Vitocal 222-G, 333-G	137
■ Minimum room volume	138
9. 3 Electrical connections for central heating and DHW heating	138
■ Power-OFF	138
■ Electrical connections, single stage heat pump: Vitocal 200-G, 300-G, 350-G	139
■ Electrical connections on 2-stage heat pump: Vitocal 300-G, 350-G	140
■ Electrical connections Vitocal 222-G	141
■ Electrical connections Vitocal 333-G	142
9. 4 Information on hydraulic connection	142
■ System examples	142
■ Two-stage heat pumps	142
■ Heat pump cascade	143
9. 5 Sizing the heat pump	143
■ Mono mode operation	143
■ Supplement for DHW heating in mono mode operation	144
■ Supplement for setback mode	144
■ Mono energetic operation	144
■ Dual mode operation	145
9. 6 Heat sources for brine/water heat pumps	145
■ Frost protection	145
■ Geothermal collector	145
■ Required brine manifolds and pipe circuits for $\dot{q}_E = 25 \text{ W/m}^2$	147
■ Geothermal probe	149
■ Required geothermal probes and brine manifolds for $\dot{q}_E = 50 \text{ W/m}$	149
■ Expansion vessel for primary circuit	151
■ Pipework, primary circuit	151
■ Percentage supplements to pump output for operation with Tyfocor	153
9. 7 Heat source for water/water heat pumps	153
■ Groundwater	153
■ Calculating the required groundwater volume	154
■ Permits for a groundwater/water heat pump system	154
■ Sizing the heat exchanger, primary intermediate circuit	154
■ Coolant	155
9. 8 Heating circuit and heat distribution	156
9. 9 Hydraulic conditions for the secondary circuit	157
■ Minimum flow rate and minimum system volume	157
■ Systems with a heating water buffer cylinder connected in parallel	157
■ Systems with heating water buffer cylinder connected in series	158
■ Systems without heating water buffer cylinder	158
9.10 Planning aids for the secondary circuit	158
9.11 Water quality and heat transfer medium	160
■ DHW	160
■ Heating water	160
■ Solar circuit heat transfer medium	160
■ Heat transfer medium, primary circuit (brine circuit)	160
9.12 DHW heating	161
■ Function description regarding DHW heating	161
■ Connection on the DHW side	161
■ Safety valve	162
■ Automatic thermostatic mixing valve	162
9.13 DHW cylinder selection	162
■ Hydraulic connection, DHW cylinder	163
9.14 Selecting cylinders for DHW heating and heating water storage	164
■ Hydraulic connection of cylinders for DHW heating and heating water storage ...	165
9.15 Loading cylinder selection	165
■ Hydraulic connection, cylinder loading system	166
■ Vitotrans 100 plate heat exchanger	168
■ Cylinder loading pump curves	170
9.16 Cooling mode	170
■ Types and configuration	170
■ Natural cooling function	170
■ Active cooling function	172
9.17 Swimming pool heating	174
■ Hydraulic connection, swimming pool	174
■ Sizing the plate heat exchanger	174
9.18 Integrating a solar thermal system	175
■ Connecting solar collectors to the Vitocal 222-G, 333-G	175
■ Sizing the solar expansion vessel	176

	9.19	Tightness test on the refrigerant circuit	176
	9.20	Intended use	177
10.		Heat pump control unit, type WO1C	
	10. 1	Vitotronic 200, type WO1C	177
		■ Design and functions	177
		■ Time switch	179
		■ Setting the operating programs	179
		■ Frost protection function	180
		■ Heating and cooling curve settings (slope and level)	180
		■ Heating systems with heating water buffer cylinder	180
		■ Outside temperature sensor	180
	10. 2	Specification Vitotronic 200, type WO1C	181
11.		Control unit accessories	
	11. 1	Overview	181
	11. 2	Photovoltaics	182
		■ Energy meter 1-phase	182
		■ Electricity meter, 3-phase	183
	11. 3	Remote control units	183
		■ Information on Vitotrol 200-A	183
		■ Vitotrol 200-A	184
	11. 4	Wireless remote control units	184
		■ Information on Vitotrol 200-RF	184
		■ Vitotrol 200-RF	184
		■ Wireless base station	185
		■ Wireless repeater	185
	11. 5	Sensors	186
		■ Contact temperature sensor	186
		■ Immersion temperature sensor	186
		■ Collector temperature sensor	186
	11. 6	Miscellaneous	187
		■ Contactor relay	187
		■ Phase monitor	187
		■ KM BUS distributor	187
	11. 7	Swimming pool temperature control	187
		■ Temperature controller for regulating the swimming pool temperature	187
	11. 8	Heating circuit control unit extension	188
		■ Mixer extension kit	188
	11. 9	Heating circuit control unit extension	188
		■ Mixer extension kit with integral mixer motor	188
		■ Mixer extension kit for separate mixer motor	189
		■ High limit safety cut-out	190
		■ Immersion thermostat	190
		■ Contact thermostat	190
	11.10	Solar DHW heating and central heating backup	191
		■ Solar control module, type SM1	191
	11.11	Function extensions	192
		■ AM1 extension	192
		■ EA1 extension	192
	11.12	Communication technology	193
		■ Vitoconnect, type OPTO2	193
12.		Keyword index	195

Product types designation

Vitocal 333-G , type

B	W	T		-		-		-		3	3	1	.	C	12
A	B	C	D	E	F	G	H	K	L	M	N				

Pos.	Value	Meaning
Ⓐ	Medium, primary circuit	
	B	Brine
	W	Water
Ⓑ	Medium, secondary circuit	
	W	Water
Ⓒ	Model, part 1	
	B	Refrigerant circuit in split version (Bi -block)
	C	Circulation pumps and/or 3-way diverter valve installed (Compact)
	H	High temperature version (High temperature)
	O	Outdoor installation (Outdoor)
	S	Heat pump, stage 2 without heat pump control unit (Slave)
Ⓓ	Model, part 2	
	T	Heat pump compact appliance (Tower)
Ⓔ	Power supply	
	M	230 V/50 Hz (Monophase)
	Not installed	400 V/50 Hz

Pos.	Value	Meaning
Ⓕ		Not for use with brine/water heat pumps
Ⓖ		Not used in brine/water heat pumps
Ⓗ		Viessmann product segment
	1	Not used in brine/water heat pumps
	2	200
	3	300
Ⓚ		DHW cylinder
	0	Separate DHW cylinder required
	1/2/3	DHW cylinder installed, without solar utilisation
	4	Not used in brine/water heat pumps
Ⓛ		Heat pumps: Number of compressors in refrigerant circuit
	1	1 compressor
	2	2 compressors (linked in parallel)
		Hybrid appliances: Number of heat sources
	2	2 heat sources, e.g. 1 compressor and 1 burner
Ⓜ	A to ...	Product generation
Ⓝ		Output size (kW)

2.1 Product description

Benefits

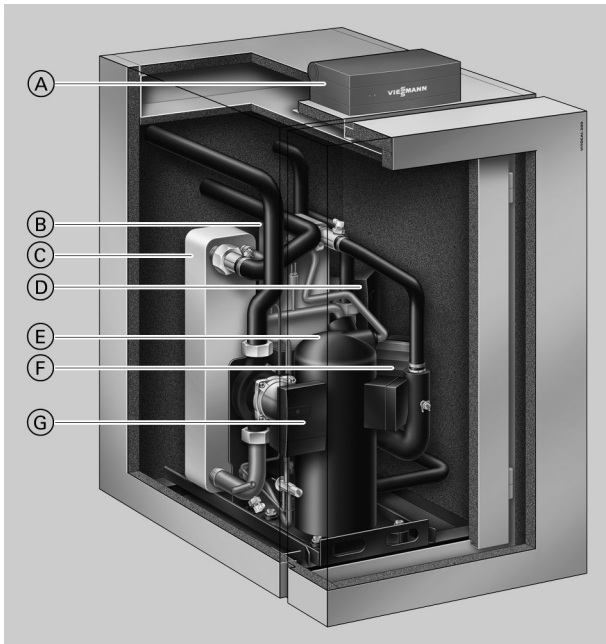

- Ⓐ Vitotronic 200 weather-compensated, digital heat pump control unit
- Ⓑ Condenser
- Ⓒ Evaporator
- Ⓓ Secondary pump (heating water), high efficiency circulation pump
- Ⓔ Hermetically sealed Compliant scroll compressor
- Ⓕ High efficiency circulation pump for cylinder heating
- Ⓖ Primary pump (brine), high efficiency circulation pump

- Low running costs thanks to a high COP to EN 14511: Up to 4.5 (B0/W35)
- Mono mode operation for central heating and DHW heating
- Maximum flow temperatures of up to 60 °C
- Low noise and vibration levels thanks to sound-optimised appliance design – sound power level < 45 dB(A)
- Easy to use Vitotronic control unit with plain text and graphic display for weather-compensated heating operation and natural cooling
- Optional installation of a booster heater, for example for screed drying
- Easy installation thanks to the integral HE circulation pump for brine and heating circuit, plus HE circulation pump for cylinder heating
- Optimised utilisation of power generated by an on-site photovoltaic system
- Control of compatible Vitovent ventilation units
- Web-enabled through Vitoconnect (accessories) for operation and service via Viessmann apps

Delivered condition

- Complete compact heat pump
- Adjustable anti-vibration feet
- Integral HE circulation pump for primary circuit (brine)
- Integral HE circulation pump for secondary circuit
- Integral high efficiency circulation pump for cylinder heating
- Safety assembly for the heating circuit (supplied)
- Weather-compensated Vitotronic 200 heat pump control unit with outside temperature sensor
- Electronic starting current limiter (not for type BWC 201.A06)

2.2 Specification

Specification

400 V appliances

BWC type		201.A06	201.A08	201.A10	201.A13	201.A17
Performance data to EN 14511 (B0/W35, 5 K spread)						
Rated heating output	kW	5.64	7.63	9.74	12.95	17.20
Cooling capacity	kW	4.37	6.01	7.69	10.30	13.66
Power consumption	kW	1.27	1.74	2.21	2.85	3.81
Coefficient of performance (COP)		4.46	4.40	4.41	4.54	4.52
Brine (primary circuit)						
Capacity	l	1.1	1.4	1.9	2.4	3.7
Minimum flow rate	l/h	820	1100	1420	1900	2520
Residual head (at minimum flow rate)	mbar	640	640	640	780	740
	kPa	64	64	64	78	74
Max. flow temperature	°C	25	25	25	25	25
Min. flow temperature	°C	-5	-5	-5	-5	-5
Heating water (secondary circuit)						
Capacity	l	1.1	1.4	1.9	2.4	3.7
Nominal flow rate	l/h	990	1310	1670	2240	2960
Residual head (at nominal flow rate)	mbar	550	530	510	340	90
	kPa	55	53	51	34	9
Minimum flow rate	l/h	520	660	850	1100	1500
Residual head (at minimum flow rate)	mbar	630	600	580	600	545
	kPa	63	60	58	60	54.5
Max. flow temperature	°C	60	60	60	60	60
Electrical values, heat pump						
Rated voltage, compressor		3/N/PE 400 V/50 Hz				
Rated current, compressor	A	5.5	6.0	8.0	10.0	15.0
Cos φ		0.9	0.9	0.9	0.9	0.9
Starting current, compressor (with starting current limiter, not for type BWC 201.A06)	A	25.0	14.0	20.0	22.0	25.0
Starting current, compressor with stalled armature	A	26.0	35.0	48.0	64.0	75.0
Compressor MCB/fuse protection	A	C16A 3-pole	B16A 3-pole	B16A 3-pole	B16A 3-pole	B20A 3-pole
Protection class		I	I	I	I	I
Electrical values, heat pump control unit						
Rated voltage		1/N/PE 230 V/50 Hz				
Fuse rating		B16A				
Fuses		2 x 6.3 A H (slow)/250 V				
Power consumption						
Power consumption of factory-fitted circulation pumps						
Primary pump	W	10 to 55	10 to 55	10 to 55	10 to 130	10 to 130
– Energy efficiency index EEI of primary pump		≤ 0.21	≤ 0.21	≤ 0.21	≤ 0.23	≤ 0.23
Secondary pump	W	10 to 55	10 to 55	10 to 55	10 to 55	10 to 55
– Energy efficiency index EEI of secondary pump		≤ 0.23	≤ 0.23	≤ 0.23	≤ 0.23	≤ 0.23
Circulation pump for cylinder heating	W	62 to 132	62 to 132	62 to 132	62 to 132	62 to 132
– Energy efficiency index EEI of circulation pump for cylinder heating		≤ 0.23	≤ 0.23	≤ 0.23	≤ 0.23	≤ 0.23
Power consumption of heat pump control unit						
– Max. power consumption	W	1000	1000	1000	1000	1000
– Power consumption in operation	W	5	5	5	5	5
Refrigerant circuit						
Refrigerant		R410A	R410A	R410A	R410A	R410A
– Refrigerant charge	kg	1.2	1.45	1.7	2.2	2.9
– Global warming potential (GWP) ^{*1}		1924	1924	1924	1924	1924
– CO ₂ equivalent	t	2.3	2.8	3.3	4.2	5.6
Compressor	Type	Hermetically sealed scroll				
Oil in compressor	Type	Emkarate RL32 3MAF				
Quantity of oil in compressor	l	0.7	0.7	1.2	1.2	1.8

^{*1} Based on the Fifth Assessment Report of the Intergovernmental Panel on Climate Change (IPCC).

Vitocal 200-G, type BWC 201.A06 to A17 (cont.)

BWC type		201.A06	201.A08	201.A10	201.A13	201.A17
Permiss. operating pressure						
Primary circuit	bar	3	3	3	3	3
	MPa	0.3	0.3	0.3	0.3	0.3
Secondary circuit	bar	3	3	3	3	3
	MPa	0.3	0.3	0.3	0.3	0.3
Dimensions						
Total length	mm	844	844	844	844	844
Total width	mm	600	600	600	600	600
Total height (programming unit pivoted up)	mm	1155	1155	1155	1155	1155
Weight						
	kg	113	117	129	135	148
Connections (male thread)						
Primary circuit flow/return	G	1½	1½	1½	1½	1½
Secondary circuit flow/return	G	1½	1½	1½	1½	1½
Sound power level (tested with reference to EN 12102/EN ISO 9614-2) Weighted total sound power level at B0 ^{±3 K} /W35 ^{±5 K}						
– At rated heating output	dB(A)	43	44	44	44	45
Energy efficiency class to EU Regulation no. 813/2013						
Heating, average climatic conditions						
– Low temperature applications (W35)		A ⁺⁺	A ⁺⁺	A ⁺⁺	A ⁺⁺	A ⁺⁺
– Medium temperature applications (W55)		A ⁺⁺	A ⁺⁺	A ⁺⁺	A ⁺⁺	A ⁺⁺
Performance data as per EU Regulation no. 813/2013 (average climatic conditions)						
Low temperature applications (W35)						
– Energy efficiency η_s	%	185	190	189	197	192
– Rated heating output P_{rated}	kW	7	9	11	15	20
– Seasonal coefficient of performance (SCOP)		4.83	4.95	4.91	5.13	5.01
Medium temperature applications (W55)						
– Energy efficiency η_s	%	125	126	131	131	135
– Rated heating output P_{rated}	kW	6	8	10	14	18
– Seasonal coefficient of performance (SCOP)		3.33	3.36	3.46	3.48	3.56

230 V appliances

Type BWC-M		201.A06	201.A08	201.A10
Performance data to EN 14511 (B0/W35, 5 K spread)				
Rated heating output	kW	5.61	7.54	9.70
Cooling capacity	kW	4.35	5.94	7.61
Power consumption	kW	1.36	1.72	2.25
Coefficient of performance (COP)		4.13	4.39	4.31
Brine (primary circuit)				
Capacity	l	1.1	1.4	1.9
Minimum flow rate	l/h	820	1100	1420
Residual head (at minimum flow rate)	mbar	640	640	640
	kPa	64	64	64
Max. flow temperature	°C	25	25	25
Min. flow temperature	°C	–5	–5	–5
Heating water (secondary circuit)				
Capacity	l	1.1	1.4	1.9
Nominal flow rate	l/h	990	1310	1670
Residual head (at nominal flow rate)	mbar	550	530	510
	kPa	55	53	51
Minimum flow rate	l/h	520	660	850
Residual head (at minimum flow rate)	mbar	630	600	580
	kPa	63	60	58
Max. flow temperature	°C	60	60	60
Electrical values, heat pump				
Rated voltage, compressor		1/N/PE 230 V/50 Hz		
Rated current, compressor	A	16.0	17.1	23.0
Cos ϕ		0.9	0.9	0.9
Starting current, compressor (with starting current limiter)	A	< 45	< 45	< 45
Starting current, compressor with stalled armature	A	58.0	67.0	97.0
Compressor MCB/fuse protection	A	B20A	B20A	B25A
		1-pole	1-pole	1-pole
Protection class		I	I	I

Vitocal 200-G, type BWC 201.A06 to A17 (cont.)

Type BWC-M		201.A06	201.A08	201.A10
Electrical values, heat pump control unit				
Rated voltage		1/N/PE 230 V/50 Hz		
Fuse rating		B16A		
Fuses		2 x 6.3 A H (slow)/250 V		
Power consumption				
Power consumption of factory-fitted circulation pumps				
Primary pump	W	10 to 55	10 to 55	10 to 55
– Energy efficiency index EEI of primary pump		≤ 0.21	≤ 0.21	≤ 0.21
Secondary pump	W	10 to 55	10 to 55	10 to 55
– Energy efficiency index EEI of secondary pump		≤ 0.23	≤ 0.23	≤ 0.23
Circulation pump for cylinder heating	W	62 to 132	62 to 132	62 to 132
– Energy efficiency index EEI of circulation pump for cylinder heating		≤ 0.23	≤ 0.23	≤ 0.23
Power consumption of heat pump control unit				
– Max. power consumption	W	1000	1000	1000
– Power consumption in operation	W	5	5	5
Refrigerant circuit				
Refrigerant		R410A	R410A	R410A
– Refrigerant charge	kg	1.2	1.45	1.7
– Global warming potential (GWP) ^{*2}		1924	1924	1924
– CO ₂ equivalent	t	2.3	2.8	3.3
Compressor	Type	Hermetically sealed scroll		
Oil in compressor	Type	Emkarate RL32 3MAF		
Quantity of oil in compressor	l	0.7	0.7	1.2
Permiss. operating pressure				
Primary circuit	bar	3	3	3
	MPa	0.3	0.3	0.3
Secondary circuit	bar	3	3	3
	MPa	0.3	0.3	0.3
Dimensions				
Total length	mm	844	844	844
Total width	mm	600	600	600
Total height (programming unit pivoted up)	mm	1155	1155	1155
Weight	kg	115	119	131
Connections (male thread)				
Primary circuit flow/return	G	1½	1½	1½
Secondary circuit flow/return	G	1½	1½	1½
Sound power level (tested with reference to EN 12102/EN ISO 9614-2) Weighted total sound power level at B0^{±3}K/W35^{±5}K				
– At rated heating output	dB(A)	43	44	44
Energy efficiency class to EU Regulation no. 813/2013				
Heating, average climatic conditions				
– Low temperature applications (W35)		A ⁺⁺	A ⁺⁺	A ⁺⁺
– Medium temperature applications (W55)		A ⁺⁺	A ⁺⁺	A ⁺⁺
Performance data as per EU Regulation no. 813/2013 (average climatic conditions)				
Low temperature applications (W35)				
– Energy efficiency η_s	%	180	194	188
– Rated heating output P_{rated}	kW	6	9	11
– Seasonal coefficient of performance (SCOP)		4.70	5.04	4.91
Medium temperature applications (W55)				
– Energy efficiency η_s	%	118	122	123
– Rated heating output P_{rated}	kW	6	8	10
– Seasonal coefficient of performance (SCOP)		3.14	3.24	3.27

*2 Based on the Fifth Assessment Report of the Intergovernmental Panel on Climate Change (IPCC).

Vitocal 200-G, type BWC 201.A06 to A17 (cont.)

Dimensions

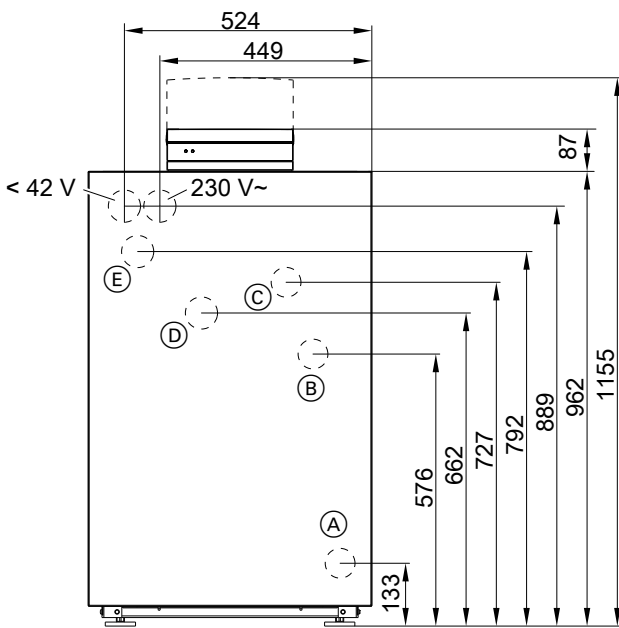

(A)	▲ ■ ⊕	Heating water return and DHW cylinder return
(B)	▼ ⊕	DHW cylinder flow (heating water side)
(C)	▼ ■	Heating water flow
(D)	⊕	Primary circuit flow (heat pump brine inlet)
(E)	▲ ⊕	Primary circuit return (heat pump brine outlet)

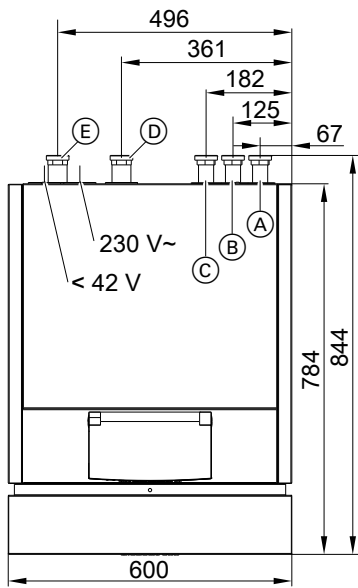

Application limits to EN 14511

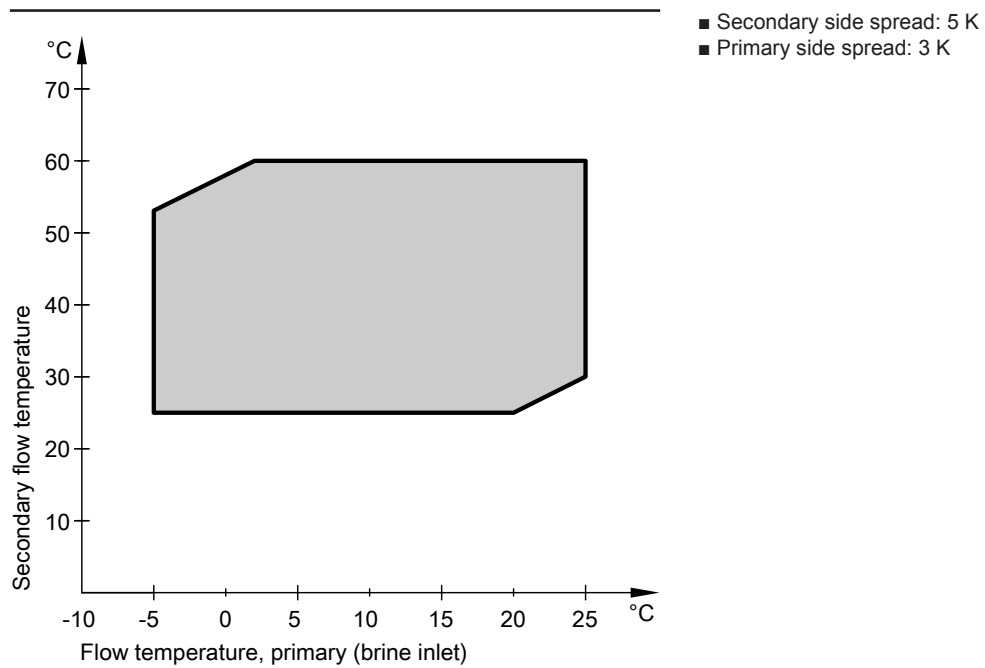

2

Curves, type BWC

Type BWC 201.A06

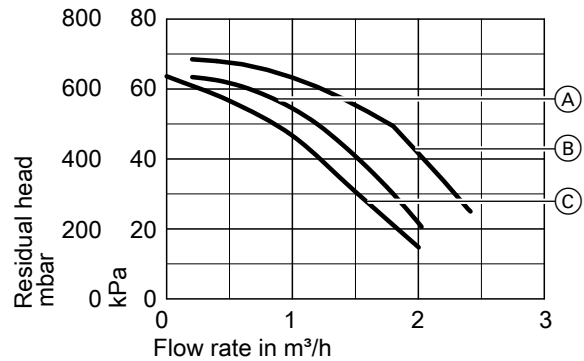
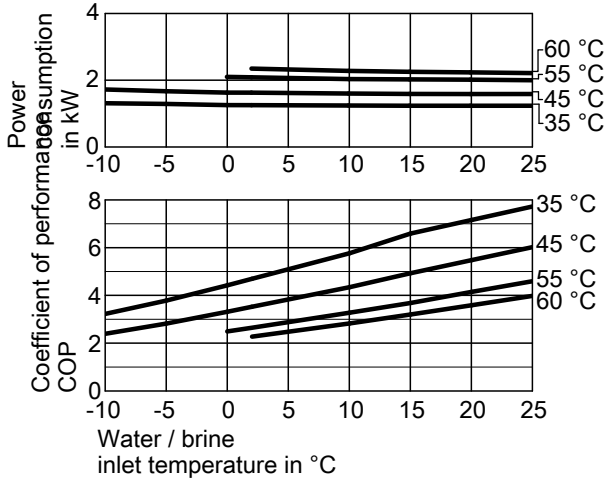
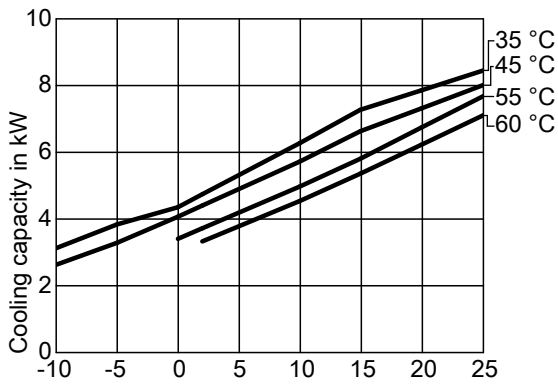
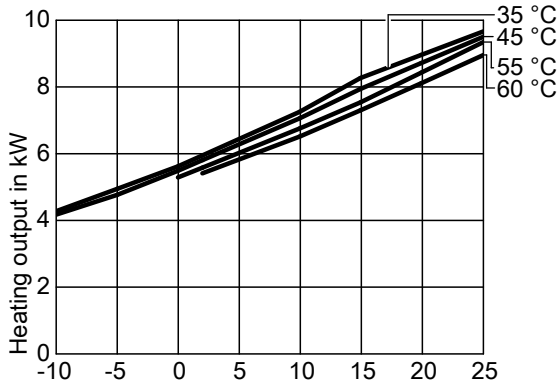

- (A) Secondary circuit (Grundfos UPML 25-85 PWM)
- (B) Primary circuit (Wilo Yonos PARA GT 25/7.5 PWM)
- (C) Circulation pump for cylinder heating (Grundfos UPM2 25-75 PWM)

Performance data

Operating point	W B	°C °C	35				
			-5	0	2	10	15
Heating output		kW	4.96	5.64	5.97	7.28	8.29
Cooling capacity		kW	3.86	4.37	4.76	6.29	7.30
Power consumption		kW	1.30	1.27	1.27	1.25	1.25
Coefficient of performance (COP)			3.81	4.46	4.73	5.81	6.64

Operating point	W B	°C °C	45				
			-5	0	2	10	15
Heating output		kW	4.79	5.51	5.83	7.08	7.97
Cooling capacity		kW	3.30	4.09	4.42	5.74	6.65
Power consumption		kW	1.68	1.65	1.64	1.62	1.60
Coefficient of performance (COP)			2.85	3.35	3.55	4.38	4.97

Operating point	W B	°C °C	55			
			0	2	10	15
Heating output		kW	5.31	5.60	6.77	7.56
Cooling capacity		kW	3.42	3.74	4.99	5.83
Power consumption		kW	2.12	2.10	2.05	2.04
Coefficient of performance (COP)			2.51	2.67	3.30	3.71

Operating point	W B	°C °C	60		
			2	10	15
Heating output		kW	5.43	6.53	7.32
Cooling capacity		kW	3.34	4.56	5.38
Power consumption		kW	2.36	2.29	2.27
Coefficient of performance (COP)			2.30	2.85	3.23

Note

COP calculated with reference to EN 14511.

Performance characteristics are determined under the following conditions:

- New appliances with clean plate heat exchangers
- Primary circuit with Tyfocor heat transfer medium, 30 % by vol.
- Secondary circuit with water

Vitocal 200-G, type BWC 201.A06 to A17 (cont.)

Type BWC 201.A08

2

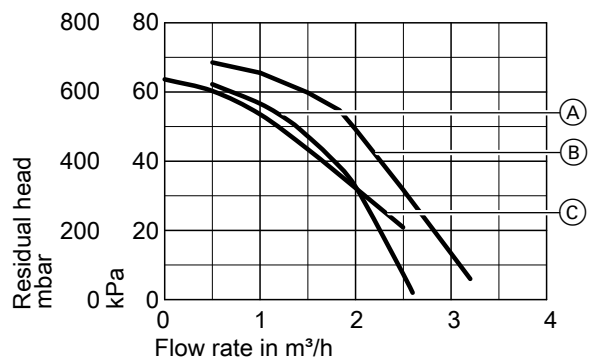
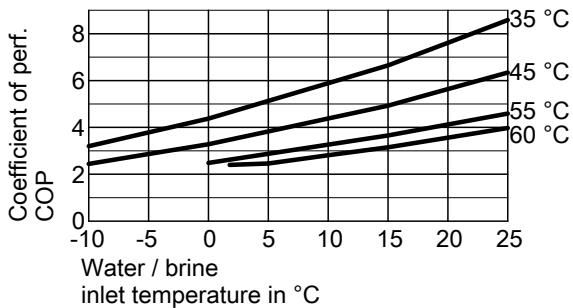
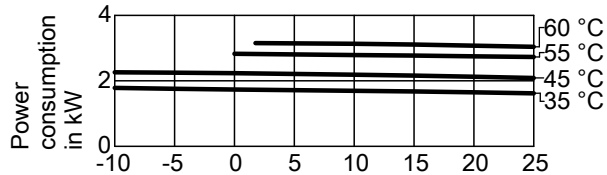
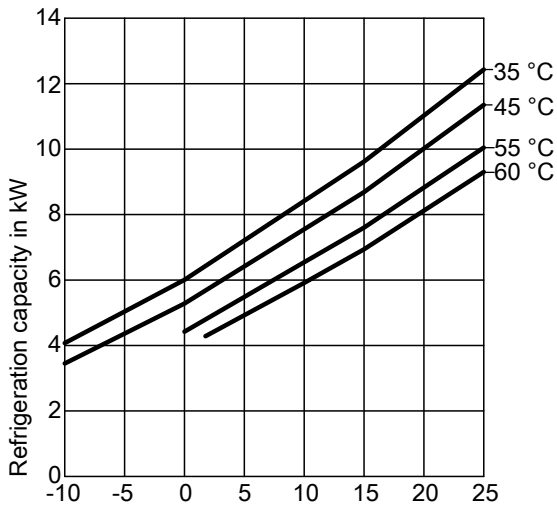
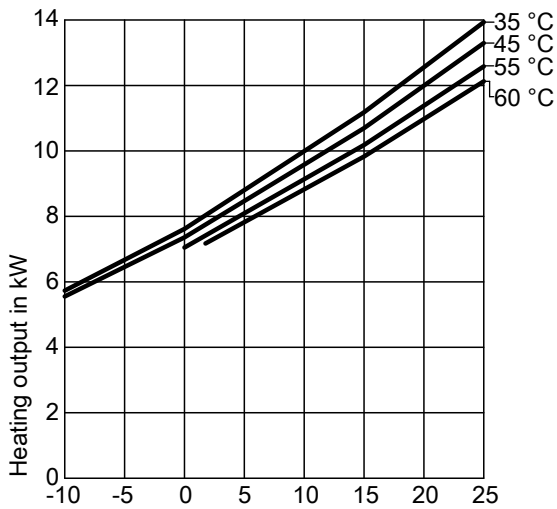

- (A) Secondary circuit (Grundfos UPML 25-85 PWM)
- (B) Primary circuit (Wilo Yonos PARA GT 25/7.5 PWM)
- (C) Circulation pump for cylinder heating (Grundfos UPM2 25-75 PWM)

Performance data

Operating point	W B	°C °C	35				
			-5	0	2	10	15
Heating output		kW	6.68	7.63	8.10	10.01	11.19
Cooling capacity		kW	5.05	6.01	6.50	8.43	9.63
Power consumption		kW	1.76	1.74	1.73	1.70	1.68
Coefficient of performance (COP)			3.81	4.40	4.70	5.91	6.67

Operating point	W B	°C °C	45				
			-5	0	2	10	15
Heating output		kW	6.46	7.37	7.81	9.60	10.71
Cooling capacity		kW	4.37	5.29	5.74	7.56	8.70
Power consumption		kW	2.25	2.24	2.23	2.19	2.16
Coefficient of performance (COP)			2.88	3.30	3.52	4.40	4.95

Operating point	W B	°C °C	55			
			0	2	10	15
Heating output		kW	7.06	7.48	9.15	10.19
Cooling capacity		kW	4.43	4.85	6.55	7.61
Power consumption		kW	2.83	2.82	2.79	2.77
Coefficient of performance (COP)			2.49	2.65	3.28	3.68

Operating point	W B	°C °C	60		
			2	10	15
Heating output		kW	7.23	8.84	9.84
Cooling capacity		kW	4.27	5.92	6.95
Power consumption		kW	3.18	3.14	3.11
Coefficient of performance (COP)			2.88	2.82	3.16

Note
COP calculated with reference to EN 14511.

Performance characteristics are determined under the following conditions:

- New appliances with clean plate heat exchangers
- Primary circuit with Tyfocor heat transfer medium, 30 % by vol.
- Secondary circuit with water

Vitocal 200-G, type BWC 201.A06 to A17 (cont.)

Type BWC 201.A10

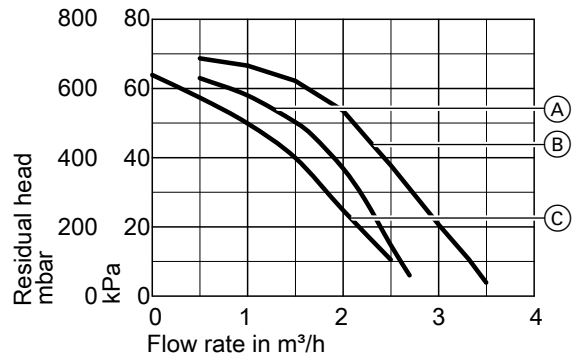
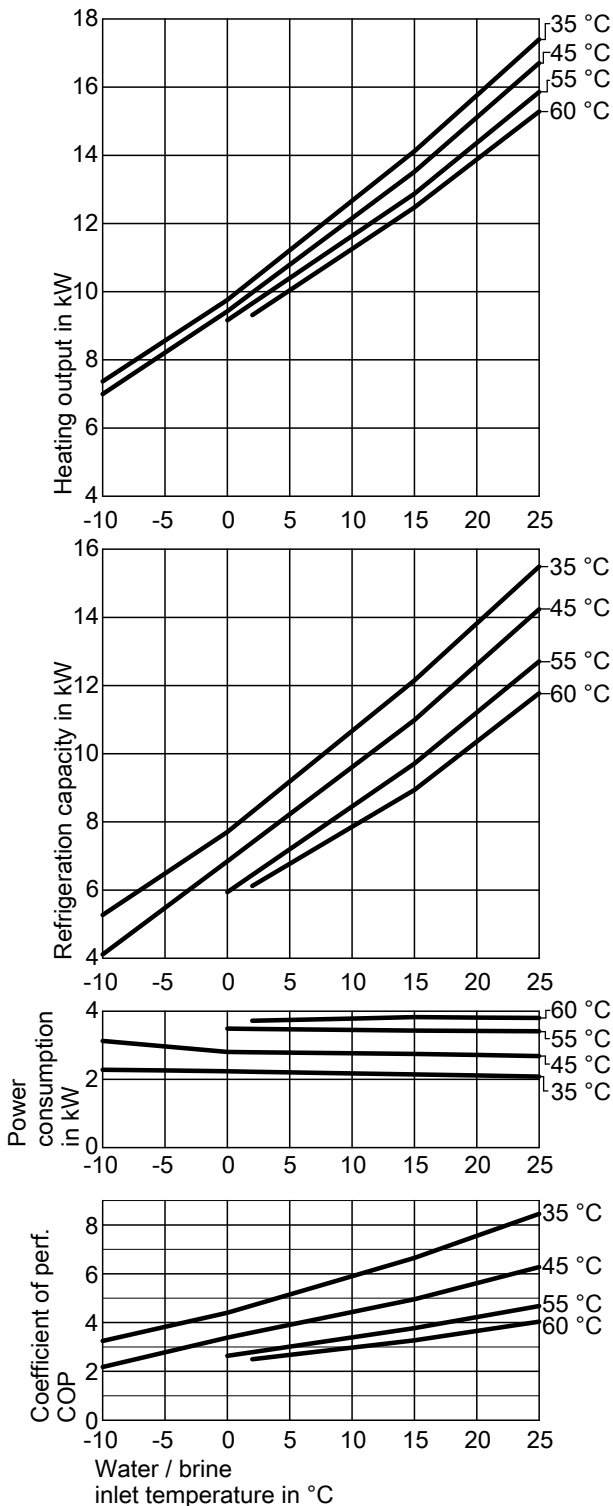

- (A) Secondary circuit (Grundfos UPML 25-85 PWM)
- (B) Primary circuit (Wilo Yonos PARA GT 25/7.5 PWM)
- (C) Circulation pump for cylinder heating (Grundfos UPM2 25-75 PWM)

Performance data

Operating point	W B	°C °C	35				
			-5	0	2	10	15
Heating output		kW	8.55	9.75	10.33	12.66	14.11
Cooling capacity		kW	6.47	7.69	8.28	10.66	12.14
Power consumption		kW	2.24	2.21	2.20	2.15	2.12
Coefficient of performance (COP)			3.83	4.41	4.71	5.90	6.65

Operating point	W B	°C °C	45				
			-5	0	2	10	15
Heating output		kW	8.20	9.41	9.96	12.14	13.51
Cooling capacity		kW	5.46	6.83	7.38	9.59	10.98
Power consumption		kW	2.94	2.78	2.77	2.74	2.72
Coefficient of performance (COP)			2.79	3.39	3.60	4.44	4.96

Operating point	W B	°C °C	55			
			0	2	10	15
Heating output		kW	9.15	9.64	11.62	12.86
Cooling capacity		kW	5.92	6.43	8.44	9.70
Power consumption		kW	3.47	3.46	3.43	3.41
Coefficient of performance (COP)			2.64	2.79	3.40	3.78

Operating point	W B	°C °C	60		
			2	10	15
Heating output		kW	9.30	11.25	12.46
Cooling capacity		kW	6.10	7.84	8.93
Power consumption		kW	3.70	3.76	3.80
Coefficient of performance (COP)			2.50	2.98	3.28

Note

COP calculated with reference to EN 14511.

Performance characteristics are determined under the following conditions:

- New appliances with clean plate heat exchangers
- Primary circuit with Tyfocor heat transfer medium, 30 % by vol.
- Secondary circuit with water

5822541

Vitocal 200-G, type BWC 201.A06 to A17 (cont.)

Type BWC 201.A13

2

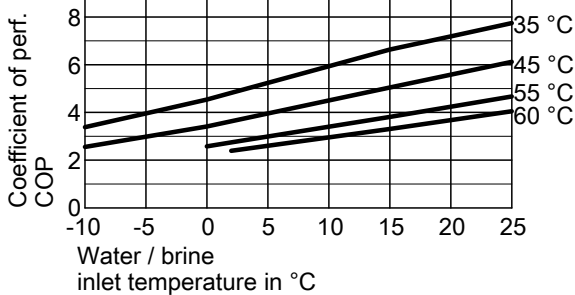
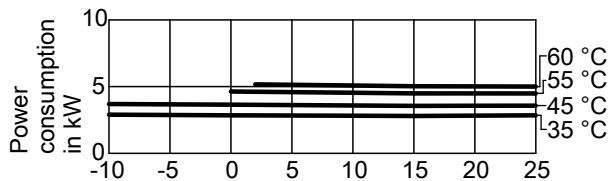
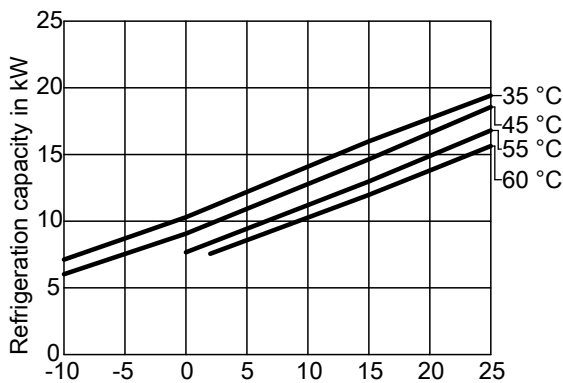
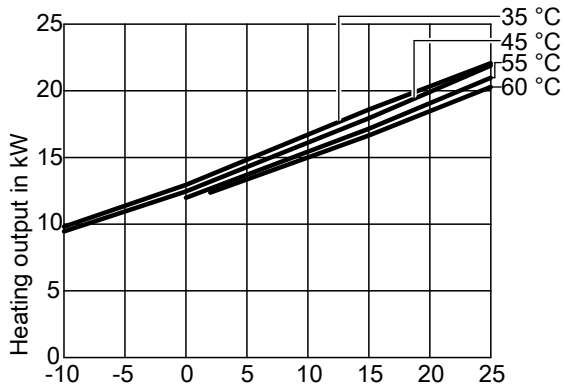

Note
COP calculated with reference to EN 14511.

Performance characteristics are determined under the following conditions:

- New appliances with clean plate heat exchangers
- Primary circuit with Tyfocor heat transfer medium, 30 % by vol.
- Secondary circuit with water

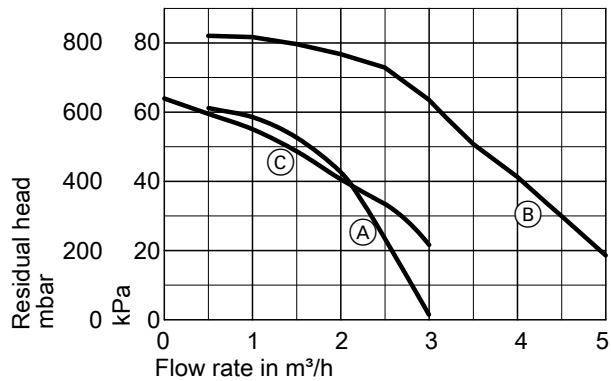

- (A) Secondary circuit (Grundfos UPML 25-85 PWM)
- (B) Primary circuit (Wilo Stratos PARA 25/1-8)
- (C) Circulation pump for cylinder heating (Grundfos UPM2 25-75)

Performance data

Operating point	W B	°C °C	35				
			-5	0	2	10	15
Heating output		kW	11.38	12.95	13.70	16.71	18.60
Cooling capacity		kW	8.71	10.30	11.06	14.09	15.99
Power consumption		kW	2.87	2.85	2.84	2.82	2.80
Coefficient of performance (COP)			3.97	4.54	4.82	5.94	6.64

Operating point	W B	°C °C	45				
			-5	0	2	10	15
Heating output		kW	10.96	12.46	13.19	16.12	17.95
Cooling capacity		kW	7.55	9.07	9.81	12.78	14.64
Power consumption		kW	3.67	3.65	3.64	3.59	3.56
Coefficient of performance (COP)			2.99	3.42	3.63	4.50	5.05

Operating point	W B	°C °C	55			
			0	2	10	15
Heating output		kW	11.98	12.67	15.43	17.16
Cooling capacity		kW	7.67	8.38	11.21	12.98
Power consumption		kW	4.64	4.62	4.54	4.50
Coefficient of performance (COP)			2.58	2.75	3.41	3.82

Operating point	W B	°C °C	60		
			2	10	15
Heating output		kW	12.37	15.01	16.65
Cooling capacity		kW	7.56	10.28	11.98
Power consumption		kW	5.17	5.09	5.03
Coefficient of performance (COP)			2.40	2.96	3.31

Vitocal 200-G, type BWC 201.A06 to A17 (cont.)

Type BWC 201.A17

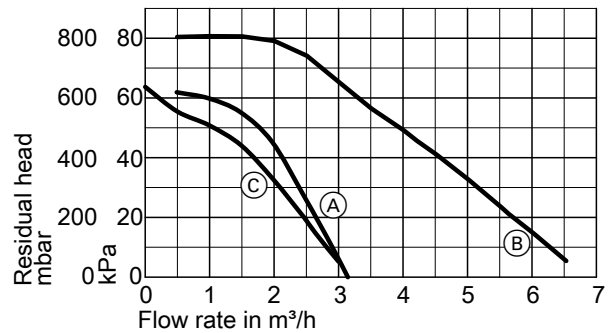
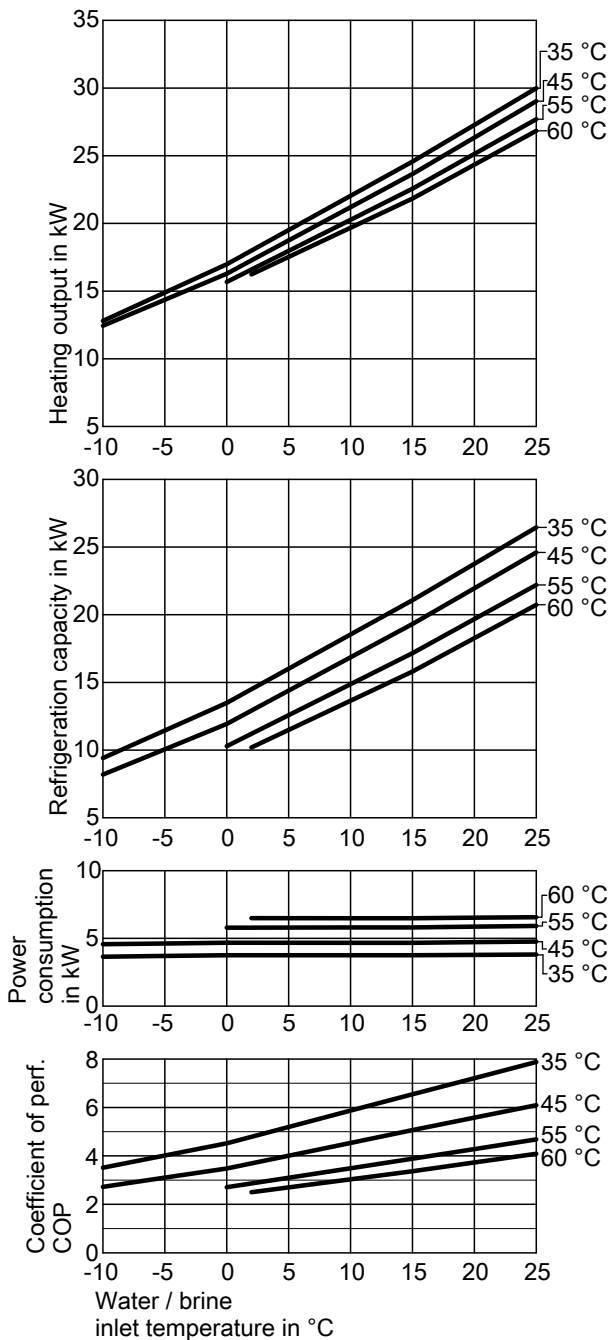

- (A) Secondary circuit (Grundfos UPML 25-85)
- (B) Primary circuit (Wilo Stratos PARA 25/1-8)
- (C) Circulation pump for cylinder heating (Grundfos UPM2 25-75)

Performance data

Operating point	W B	°C °C	35				
			-5	0	2	10	15
Heating output		kW	14.89	17.20	17.99	22.04	24.56
Cooling capacity		kW	11.45	13.66	14.50	18.54	21.07
Power consumption		kW	3.70	3.81	3.76	3.76	3.75
Coefficient of performance (COP)			4.02	4.52	4.79	5.87	6.55

Operating point	W B	°C °C	45				
			-5	0	2	10	15
Heating output		kW	14.36	16.29	17.27	21.20	23.65
Cooling capacity		kW	10.06	11.93	12.92	16.85	19.31
Power consumption		kW	4.62	4.68	4.68	4.67	4.67
Coefficient of performance (COP)			3.10	3.48	3.69	4.54	5.07

Operating point	W B	°C °C	55			
			0	2	10	15
Heating output		kW	15.67	16.59	20.27	22.56
Cooling capacity		kW	10.29	11.20	14.87	17.16
Power consumption		kW	5.79	5.79	5.81	5.81
Coefficient of performance (COP)			2.71	2.86	3.49	3.88

Operating point	W B	°C °C	60		
			2	10	15
Heating output		kW	16.23	19.68	21.84
Cooling capacity		kW	10.19	13.65	15.81
Power consumption		kW	6.50	6.49	6.49
Coefficient of performance (COP)			2.50	3.03	3.37

Note

COP calculated with reference to EN 14511.

Performance characteristics are determined under the following conditions:

- New appliances with clean plate heat exchangers
- Primary circuit with Tyfocor heat transfer medium, 30 % by vol.
- Secondary circuit with water

Curves, type BWC-M

Type BWC-M 201.A06

2

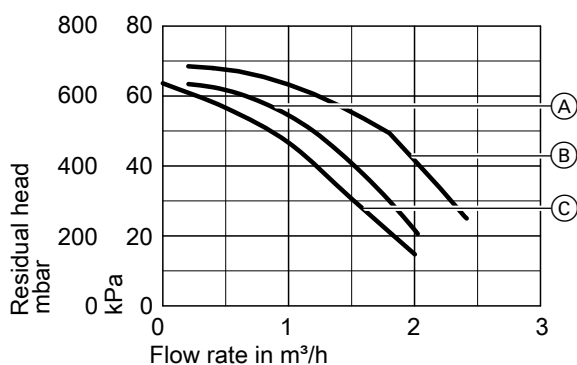
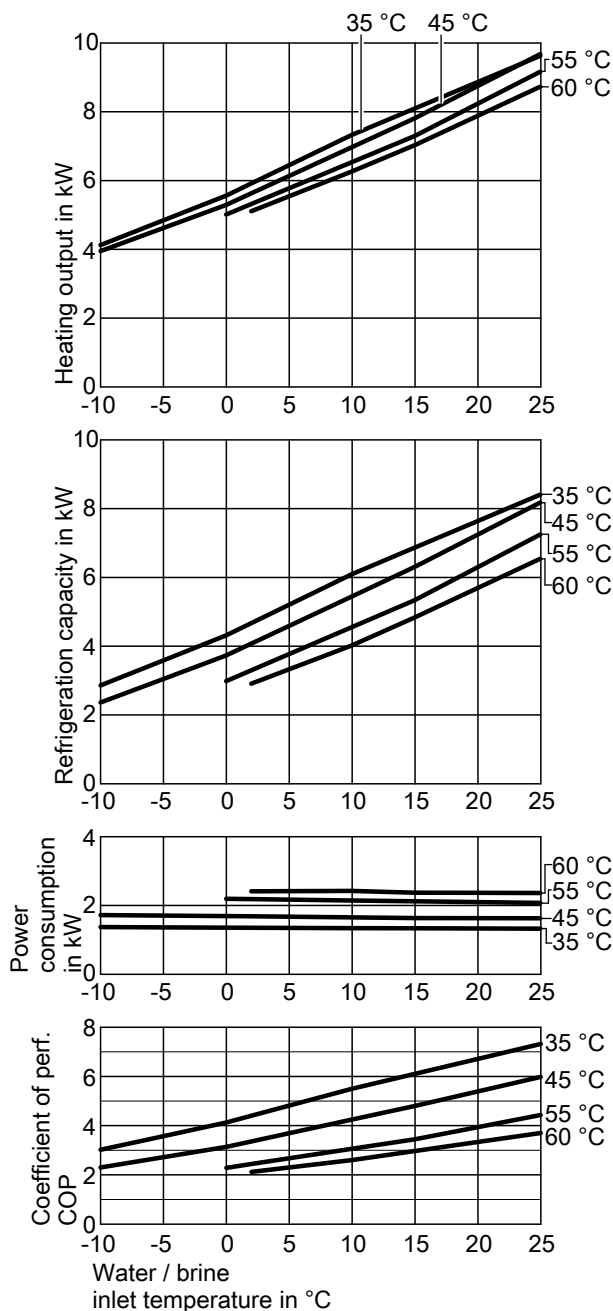

- (A) Secondary circuit (Grundfos UPML 25-85 PWM)
- (B) Primary circuit (Wilo Yonos PARA GT 25/7.5 PWM)
- (C) Circulation pump for cylinder heating (Grundfos UPM2 25-75)

Performance data

Operating point	W B	°C °C	35				
			-5	0	2	10	15
Heating output		kW	4.84	5.56	5.91	7.32	8.09
Cooling capacity		kW	3.58	4.31	4.66	6.09	6.86
Power consumption		kW	1.35	1.34	1.34	1.33	1.32
Coefficient of performance (COP)			3.58	4.14	4.41	5.51	6.12

Operating point	W B	°C °C	45				
			-5	0	2	10	15
Heating output		kW	4.61	5.29	5.62	6.97	7.81
Cooling capacity		kW	3.04	3.72	4.07	5.44	6.30
Power consumption		kW	1.70	1.68	1.67	1.64	1.62
Coefficient of performance (COP)			2.72	3.14	3.37	4.25	4.81

Operating point	W B	°C °C	55			
			0	2	10	15
Heating output		kW	5.00	5.31	6.53	7.29
Cooling capacity		kW	2.97	3.29	4.54	5.33
Power consumption		kW	2.18	2.17	2.14	2.11
Coefficient of performance (COP)			2.29	2.45	3.07	3.46

Operating point	W B	°C °C	60		
			2	10	15
Heating output		kW	5.10	6.26	7.03
Cooling capacity		kW	2.90	4.01	4.83
Power consumption		kW	2.40	2.41	2.36
Coefficient of performance (COP)			2.13	2.61	2.98

Note
COP calculated with reference to EN 14511.

Performance characteristics are determined under the following conditions:

- New appliances with clean plate heat exchangers
- Primary circuit with Tyfocor heat transfer medium, 30 % by vol.
- Secondary circuit with water

Vitocal 200-G, type BWC 201.A06 to A17 (cont.)

Type BWC-M 201.A08

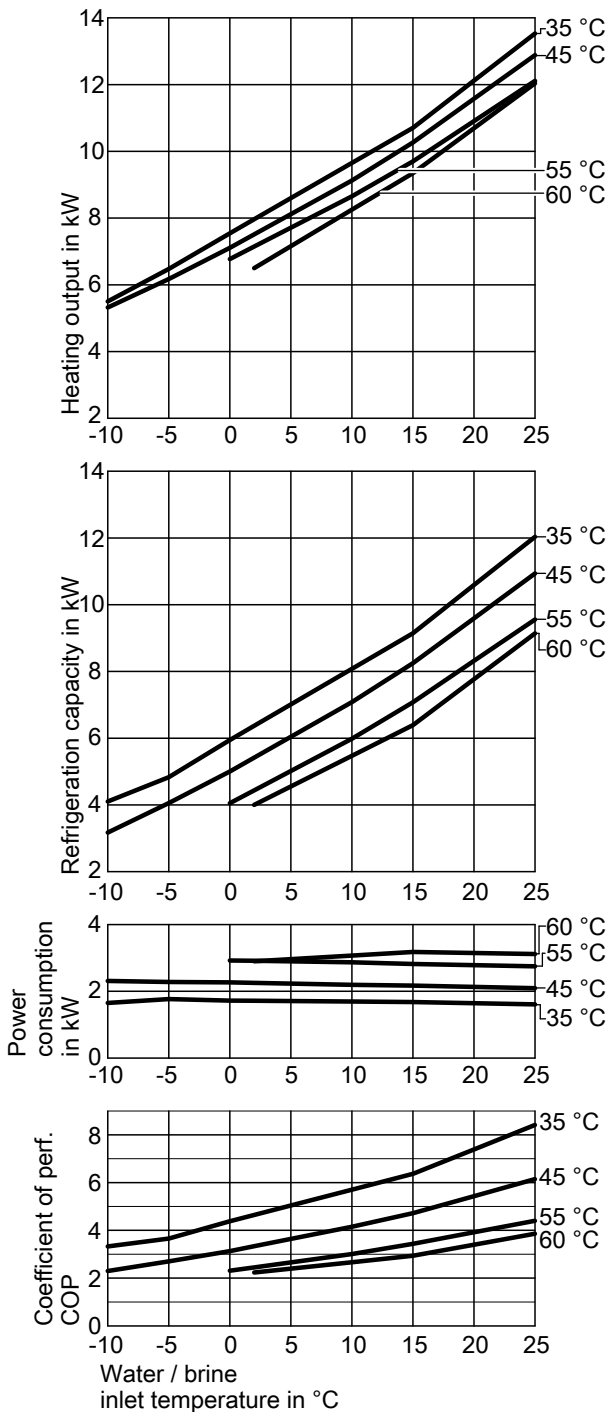

Note

COP calculated with reference to EN 14511.

Performance characteristics are determined under the following conditions:

- New appliances with clean plate heat exchangers
- Primary circuit with Tyfocor heat transfer medium, 30 % by vol.
- Secondary circuit with water

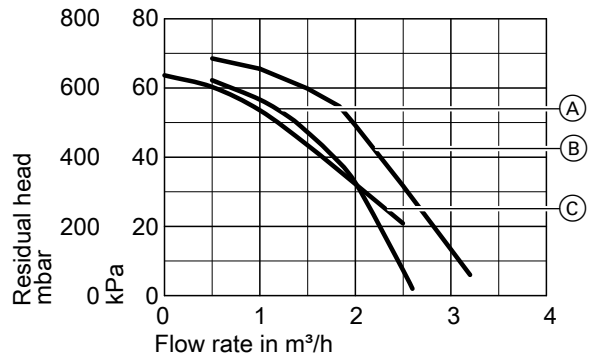

- (A) Secondary circuit (Grundfos UPML 25-85)
- (B) Primary circuit (Wilo Yonos PARA GT 25/7.5 PWM)
- (C) Circulation pump for cylinder heating (Grundfos UPM2 25-75 PWM)

Performance data

Operating point	W B	°C °C	35				
			-5	0	2	10	15
Heating output	kW		6.48	7.54	7.97	9.65	10.70
Cooling capacity	kW		4.83	5.94	6.37	8.08	9.14
Power consumption	kW		1.77	1.72	1.71	1.69	1.68
Coefficient of performance (COP)			3.66	4.39	4.65	5.71	6.37

Operating point	W B	°C °C	45				
			-5	0	2	10	15
Heating output	kW		6.17	7.11	7.51	9.12	10.27
Cooling capacity	kW		4.05	5.00	5.42	7.08	8.25
Power consumption	kW		2.28	2.27	2.25	2.20	2.17
Coefficient of performance (COP)			2.71	3.14	3.34	4.16	4.73

Operating point	W B	°C °C	55			
			0	2	10	15
Heating output	kW		6.77	7.15	8.65	9.70
Cooling capacity	kW		4.05	4.44	5.98	7.08
Power consumption	kW		2.92	2.91	2.87	2.82
Coefficient of performance (COP)			2.31	2.46	3.01	3.44

Operating point	W B	°C °C	60		
			2	10	15
Heating output	kW		6.50	8.25	9.35
Cooling capacity	kW		4.00	5.47	6.39
Power consumption	kW		2.90	3.07	3.18
Coefficient of performance (COP)			2.24	2.67	2.94

Vitocal 200-G, type BWC 201.A06 to A17 (cont.)

Type BWC-M 201.A10

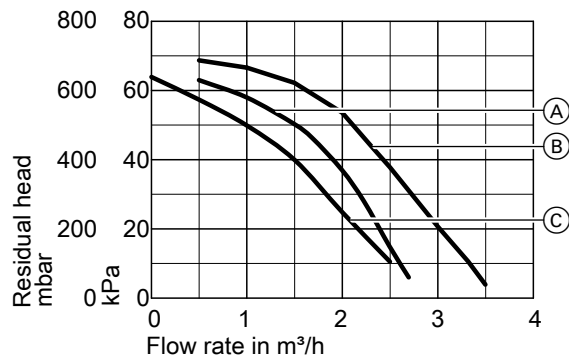
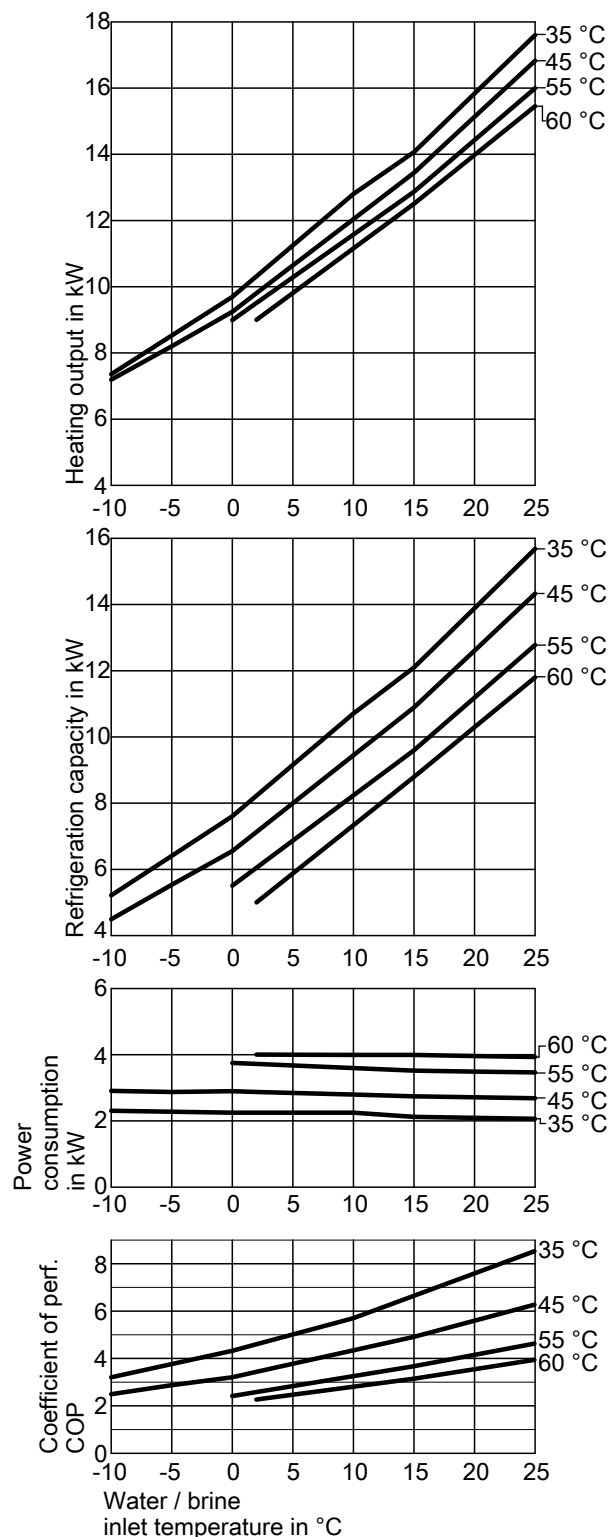

- (A) Secondary circuit (Grundfos UPML 25-85 PWM)
- (B) Primary circuit (Wilo Yonos PARA GT 25/7.5 PWM)
- (C) Circulation pump for cylinder heating (Grundfos UPM2 25-75 PWM)

Performance data

Operating point	W B	°C °C	35				
			-5	0	2	10	15
Heating output		kW	8.53	9.70	10.32	12.80	14.07
Cooling capacity		kW	6.41	7.61	8.23	10.71	12.10
Power consumption		kW	2.28	2.25	2.25	2.25	2.12
Coefficient of performance (COP)			3.75	4.31	4.59	5.69	6.64

Operating point	W B	°C °C	45				
			-5	0	2	10	15
Heating output		kW	8.20	9.24	9.80	12.04	13.44
Cooling capacity		kW	5.53	6.55	7.13	9.45	10.89
Power consumption		kW	2.87	2.90	2.88	2.79	2.74
Coefficient of performance (COP)			2.86	3.19	3.42	4.33	4.90

Operating point	W B	°C °C	55			
			0	2	10	15
Heating output		kW	8.99	9.51	11.58	12.87
Cooling capacity		kW	5.51	6.05	8.23	9.60
Power consumption		kW	3.75	3.72	3.60	3.52
Coefficient of performance (COP)			2.40	2.57	3.24	3.66

Operating point	W B	°C °C	60		
			2	10	15
Heating output		kW	9.00	11.16	12.51
Cooling capacity		kW	5.00	7.34	8.80
Power consumption		kW	4.00	4.00	3.99
Coefficient of performance (COP)			2.25	2.79	3.13

Note
COP calculated with reference to EN 14511.

Performance characteristics are determined under the following conditions:

- New appliances with clean plate heat exchangers
- Primary circuit with Tyfocor heat transfer medium, 30 % by vol.
- Secondary circuit with water

3.1 Product description

Benefits of type BW, BWS

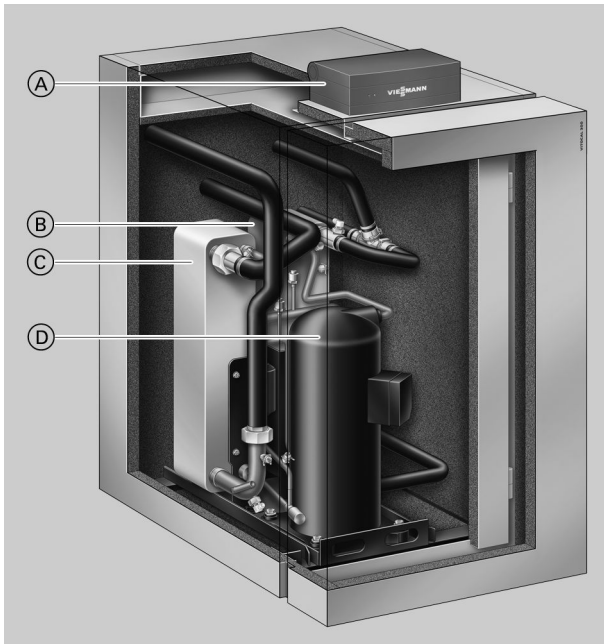

- (A) Vitotronic 200 weather-compensated, digital heat pump control unit
- (B) Condenser
- (C) Evaporator
- (D) Hermetically sealed Compliant scroll compressor

- Low running costs thanks to a high COP to EN 14511: Up to 5.0 (B0/W35)
- Mono mode operation for central heating and DHW heating
- Maximum flow temperatures of up to 65 °C for high DHW convenience
- Low noise and vibration levels through sound-optimised appliance design – sound power level < 42 dB(A)
- Low running costs with the highest level of efficiency at any operating point through the innovative Refrigerant Cycle Diagnostic (RCD) system with electronic expansion valve (EEV)
- With the 2-stage version (type BW+BWS):
Highly flexible due to option of combining modules of different outputs
Easier handling through smaller and lighter modules

Only type BW:

- Easy to use Vitotronic control unit with plain text and graphic display for weather-compensated heating mode and natural and active cooling
- Optional installation of an instantaneous heating water heater, for example for screed drying
- Optimised utilisation of power generated by an on-site photovoltaic system
- Control of compatible Vitovent ventilation units
- Web-enabled through Vitoconnect (accessories) for operation and service via Viessmann apps

Delivered condition, type BW

- Complete compact heat pump as a single stage heat pump or as stage 1 (master) of a two-stage heat pump
- Adjustable anti-vibration feet
- Weather-compensated Vitotronic 200 heat pump control unit with outside temperature sensor
- Electronic starting current limiter (not for type BW 301.B06) and integral phase monitor

Delivered condition, type BWS

- Compact heat pump as stage 2 (slave)
- Adjustable anti-vibration feet
- Electrical connecting cable for connection to stage 1 (master).
- Electronic starting current limiter (not for type BWS 301.B06).

Benefits of type BWC

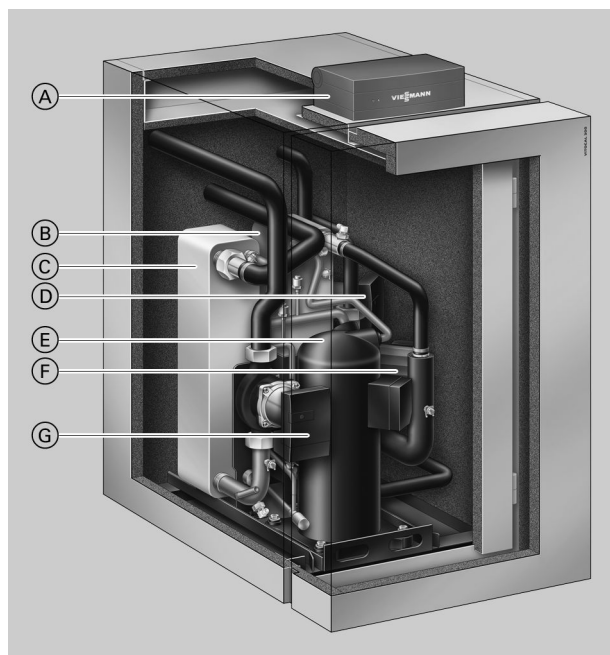

- Ⓐ Vitotronic 200 weather-compensated, digital heat pump control unit
- Ⓑ Condenser
- Ⓒ Evaporator
- Ⓓ Secondary pump (heating water), high efficiency circulation pump
- Ⓔ Hermetically sealed Compliant scroll compressor
- Ⓕ High efficiency circulation pump for cylinder heating
- Ⓖ Primary pump (brine), high efficiency circulation pump

3

- Low running costs thanks to a high COP to EN 14511: Up to 5.0 (B0/W35)
- Mono mode operation for central heating and DHW heating
- Maximum flow temperatures of up to 65 °C for high DHW convenience
- Low noise and vibration levels through sound-optimised appliance design – sound power level < 42 dB(A)
- Low running costs with the highest level of efficiency at any operating point through the innovative Refrigerant Cycle Diagnostic (RCD) system with electronic expansion valve (EEV)
- Easy to use Vitotronic control unit with plain text and graphic display for weather-compensated heating mode and natural and active cooling
- Optional installation of an instantaneous heating water heater, for example for screed drying
- Optimised utilisation of power generated by an on-site photovoltaic system
- Control of compatible Vitovent ventilation units
- Web-enabled through Vitoconnect (accessories) for operation and service via Viessmann apps

Delivered condition, type BWC

- Complete compact heat pump
- Adjustable anti-vibration feet
- Integral HE brine circuit pump (primary circuit)
- Integral HE circulation pump for secondary circuit
- Integral HE circulation pump for cylinder heating
- Safety assembly for the heating circuit (supplied)
- Weather-compensated Vitotronic 200 heat pump control unit with outside temperature sensor
- Electronic starting current limiter (not for type BWC 301.B06) and integral phase monitor

3.2 Specification

Specification for brine/water heat pumps

Type BWC/BW/BWS		301.B06	301.B08	301.B10	301.B13	301.B17
Performance data to EN 14511 (B0/W35, 5 K spread)						
Rated heating output	kW	5.69	7.64	10.36	12.99	17.24
Cooling capacity	kW	4.54	6.13	8.43	10.57	13.85
Power consumption	kW	1.24	1.62	2.07	2.60	3.65
Coefficient of performance (COP)		4.60	4.71	5.01	5.00	4.73
Brine (primary circuit)						
Capacity	l	3.0	3.4	4.0	4.5	5.9
Minimum flow rate	l/h	860	1160	1470	1880	2490
Flow pressure drop at minimum flow rate (type BW/BWS 301.B only)	mbar kPa	22 2.2	25 2.5	25 2.5	45 4.5	50 5.0
Residual head at minimum flow rate (type BWC 301.B only)	mbar kPa	670 67.0	660 66.0	810 81.0	780 78.0	796 79.6
Max. flow temperature (brine inlet)	°C	25	25	25	25	25
Min. flow temperature (brine inlet)	°C	-10	-10	-10	-10	-10
Heating water (secondary circuit)						
Capacity	l	3.0	3.5	4.0	4.6	5.7
Nominal flow rate	l/h	990	1320	1780	2230	2980
Pressure drop at nominal flow rate (type BW/BWS 301.B only)	mbar kPa	30 3	40 4	50 5	80 8	120 12
Residual head at nominal flow rate (type BWC 301.B only)	mbar kPa	760 76	690 69	630 63	480 48	260 26
Minimum flow rate	l/h	520	680	880	1080	1490
Flow pressure drop at minimum flow rate (type BW/BWS 301.B only)	mbar kPa	10 1.0	12 1.2	14 1.4	18 1.8	34 3.4
Residual head at minimum flow rate (type BWC 301.B only)	mbar kPa	800 80.0	790 79.0	710 71.0	721 72.1	668 66.8
Max. flow temperature	°C	65	65	65	65	65
Electrical values, heat pump						
Rated voltage, compressor		3/N/PE 400 V/50 Hz				
Rated current, compressor	A	4.8	6.2	7.4	9.7	13.0
Cos φ		0.9	0.9	0.9	0.9	0.9
Starting current compressor with starting current limiter (not for type BWC/BW/BWS 301.B06)	A	25.0	14.0	20.0	22.0	25.0
Starting current, compressor with stalled armature	A	28.0	43.0	51.5	62.0	75.0
Compressor MCB/fuse protection	A	C16A 3-pole	B16A 3-pole	B16A 3-pole	B16A 3-pole	C20A 3-pole
Protection class		I	I	I	I	I
Electrical values, heat pump control unit (type BWC/BW 301.B only)						
Rated voltage		1/N/PE 230 V/50 Hz				
Fuse rating		B16A				
Fuses		2 x 6.3 A H (slow)/250 V				
Power consumption						
Power consumption of factory-fitted circulation pumps (type BWC 301.B only)						
Primary pump	W	5 to 70	5 to 70	5 to 70	8 to 130	8 to 130
– Energy efficiency index EEI of primary pump		≤ 0.21	≤ 0.21	≤ 0.21	≤ 0.23	≤ 0.23
Secondary pump	W	5.7 to 87	5.7 to 87	5.7 to 87	5.7 to 87	5.7 to 87
– Energy efficiency index EEI of secondary pump		≤ 0.23	≤ 0.23	≤ 0.23	≤ 0.23	≤ 0.23
Circulation pump for cylinder heating	W	3.8 to 70	3.8 to 70	3.8 to 70	3.8 to 70	3.8 to 70
– Energy efficiency index EEI of circulation pump for cylinder heating		≤ 0.23	≤ 0.23	≤ 0.23	≤ 0.23	≤ 0.23
Power consumption of heat pump control unit						
– Max. power consumption	W	1000	1000	1000	1000	1000
– Power consumption in operation	W	5	5	5	5	5

Vitocal 300-G, type BW 301.B06 to B17, BWS 301.B06 to B17, BWC 301.B06 to B17 (cont.)

Type BWC/BW/BWS		301.B06	301.B08	301.B10	301.B13	301.B17
Refrigerant circuit						
Refrigerant		R410A	R410A	R410A	R410A	R410A
– Refrigerant charge	kg	1.4	1.95	2.4	2.25	2.75
– Global warming potential (GWP) ^{*3}		1924	1924	1924	1924	1924
– CO ₂ equivalent	t	2.7	3.8	4.6	4.3	5.3
Permissible operating pressure						
– Low pressure	bar	28	28	28	28	28
	MPa	2.8	2.8	2.8	2.8	2.8
– High pressure	bar	45	45	45	45	45
	MPa	4.5	4.5	4.5	4.5	4.5
Compressor	Type	Hermetically sealed scroll				
Oil in compressor	Type	Emkarate RL32 3MAF				
Quantity of oil in compressor	l	0.74	1.24	1.24	1.24	1.89
Permiss. operating pressure						
Primary circuit	bar	3	3	3	3	3
	MPa	0.3	0.3	0.3	0.3	0.3
Secondary circuit	bar	3	3	3	3	3
	MPa	0.3	0.3	0.3	0.3	0.3
Dimensions						
Total length	mm	844	844	844	844	844
Total width	mm	600	600	600	600	600
Total height (programming unit pivoted up)	mm	1155	1155	1155	1155	1155
Weight						
Heat pump, type BWC 301.B	kg	123	127	139	145	158
Heat pump stage 1, type BW 301.B	kg	113	117	129	135	148
Heat pump stage 2, type BWS 301.B	kg	109	113	125	131	144
Connections (male thread)						
Primary circuit flow/return	G	1½	1½	1½	1½	1½
Secondary circuit flow/return	G	1½	1½	1½	1½	1½
Sound power level (tested with reference to EN 12102/EN ISO 9614-2) Weighted total sound power level at B0 ^{±3 K} /W35 ^{±5 K}						
– At rated heating output	dB(A)	40	41	41	41	42
Energy efficiency class to EU Regulation no. 813/2013						
Heating, average climatic conditions						
– Low temperature applications (W35)		A ⁺⁺	A ⁺⁺	A ⁺⁺	A ⁺⁺	A ⁺⁺
– Medium temperature applications (W55)		A ⁺⁺	A ⁺⁺	A ⁺⁺	A ⁺⁺	A ⁺⁺
Performance data as per EU Regulation no. 813/2013 (average climatic conditions)						
Low temperature applications (W35)						
– Energy efficiency η_s	%	182	198	209	191	196
– Rated heating output P_{rated}	kW	7	9	12	15	20
– Seasonal coefficient of performance (SCOP)		4.75	5.15	5.43	4.98	5.10
Medium temperature applications (W55)						
– Energy efficiency η_s	%	133	145	153	146	150
– Rated heating output P_{rated}	kW	6	8	11	14	19
– Seasonal coefficient of performance (SCOP)		3.53	3.83	4.03	3.85	3.95

Water/water heat pump specification

Type BWC/BW/BWS in conjunction with "conversion kit for water/water heat pump"		301.B06	301.B08	301.B10	301.B13	301.B17
Performance data to EN 14511 (W10/W35, 5 K spread)						
Rated heating output	kW	7.51	10.18	13.51	16.89	22.59
Cooling capacity	kW	6.35	8.74	11.60	14.46	19.17
Power consumption	kW	1.24	1.55	2.05	2.61	3.68
Coefficient of performance (COP)		6.05	6.58	6.58	6.46	6.15

^{*3} Based on the Fifth Assessment Report of the Intergovernmental Panel on Climate Change (IPCC).

Vitocal 300-G, type BW 301.B06 to B17, BWS 301.B06 to B17, BWC 301.B06 to B17 (cont.)

Type BWC/BW/BWS in conjunction with "conversion kit for water/water heat pump"		301.B06	301.B08	301.B10	301.B13	301.B17
Brine (primary intermediate circuit)						
Capacity	l	3.0	3.4	4.0	4.5	5.9
Minimum flow rate	l/h	1530	2000	2570	3300	4450
Flow pressure drop at minimum flow rate (type BW/BWS only)	mbar	58	76	61	122	143
	kPa	5.8	7.6	6.1	12.2	14.3
Residual head at minimum flow rate (type BWC only)	mbar	613	520	770	624	290
	kPa	61.3	52.0	77.0	62.4	29.0
Max. flow temperature (brine inlet)	°C	25	25	25	25	25
Min. flow temperature (brine inlet)	°C	7.5	7.5	7.5	7.5	7.5
Heating water (secondary circuit)						
Capacity	l	3.0	3.5	4.0	4.6	5.7
Minimum flow rate	l/h	690	900	1170	1450	1990
Flow pressure drop at minimum flow rate (type BW/BWS only)	mbar	16	20	29	39	58
	kPa	1.6	2.0	2.9	3.9	5.8
Residual head at minimum flow rate (type BWC only)	mbar	791	755	690	660	540
	kPa	79.1	75.5	69.0	66.0	54.0
Max. flow temperature	°C	65	65	65	65	65

Note

Further specifications: See "Specification for brine/water heat pumps"

Dimensions, type BW, BWS

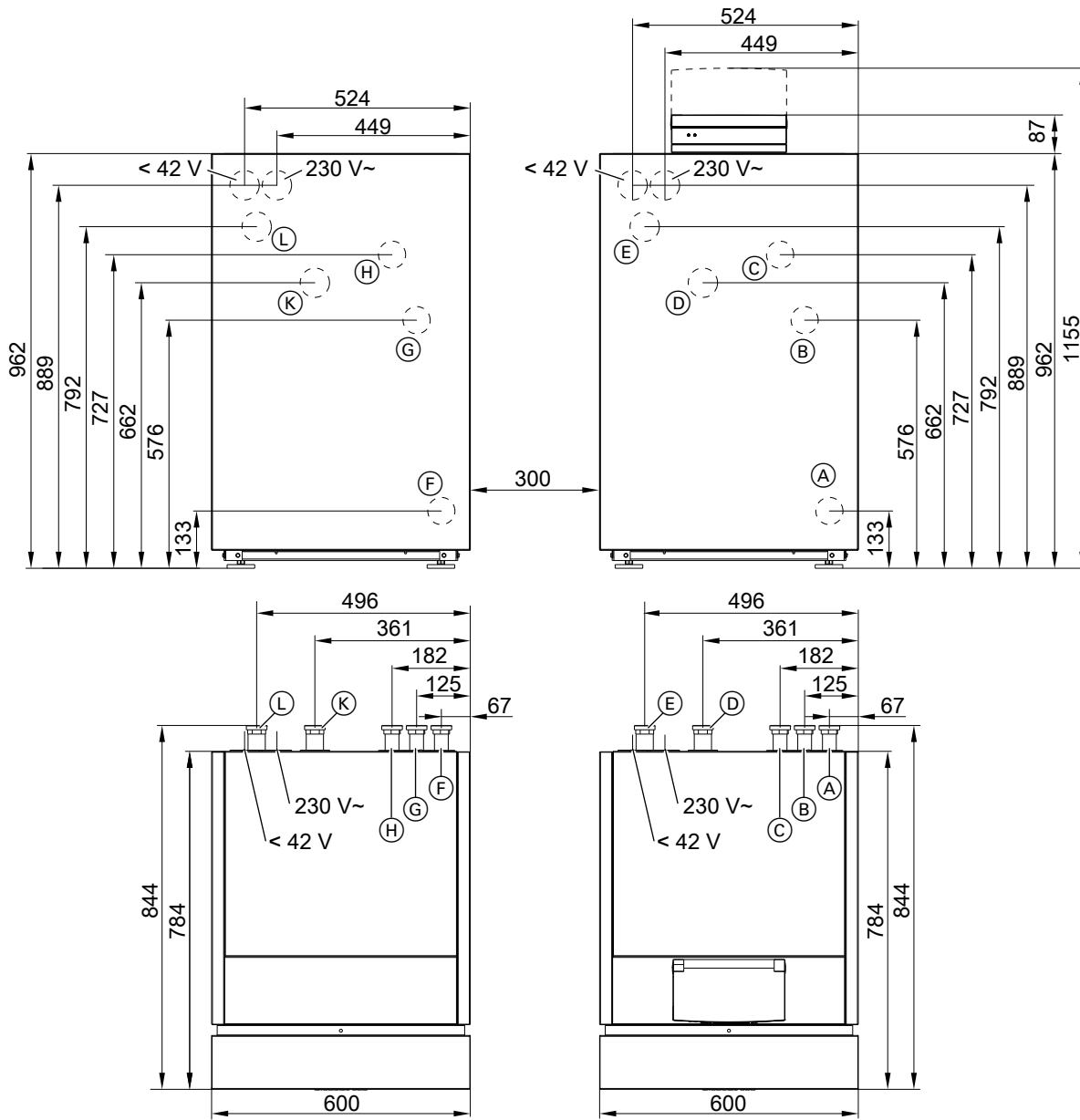

Type BWS on the left; type BW on the right

(A)/(F)	▲ ■	Heating water return and DHW cylinder return
(B)/(G)	▼ ■	DHW cylinder flow (heating water side)
(C)/(H)	▼ ■	Heating water flow
(D)/(K)	▲ ■	Primary circuit flow (heat pump brine inlet)
(E)/(L)	▲ ▼	Primary circuit return (heat pump brine outlet)

Dimensions, type BWC

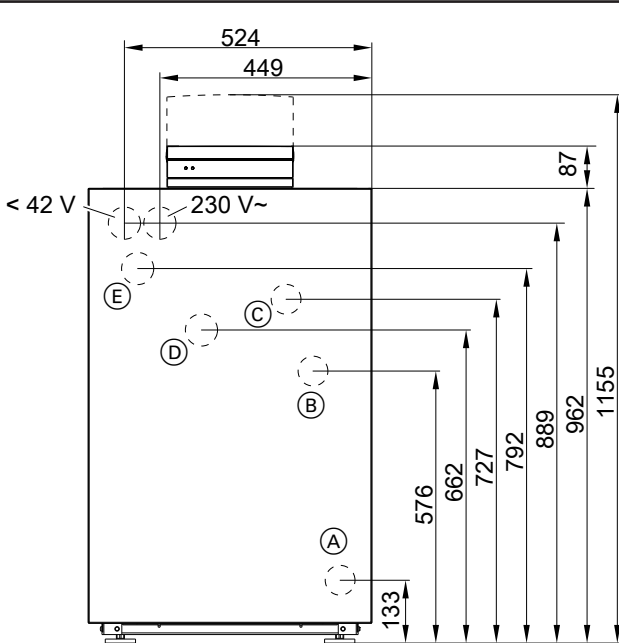

(A)		Heating water return and DHW cylinder return
(B)		DHW cylinder flow (heating water side)
(C)		Heating water flow
(D)		Primary circuit flow (heat pump brine inlet)
(E)		Primary circuit return (heat pump brine outlet)

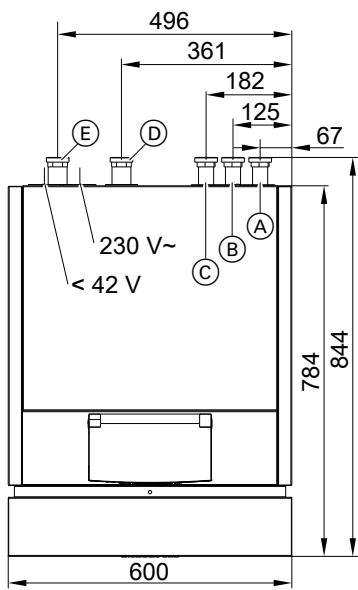

Application limits to EN 14511

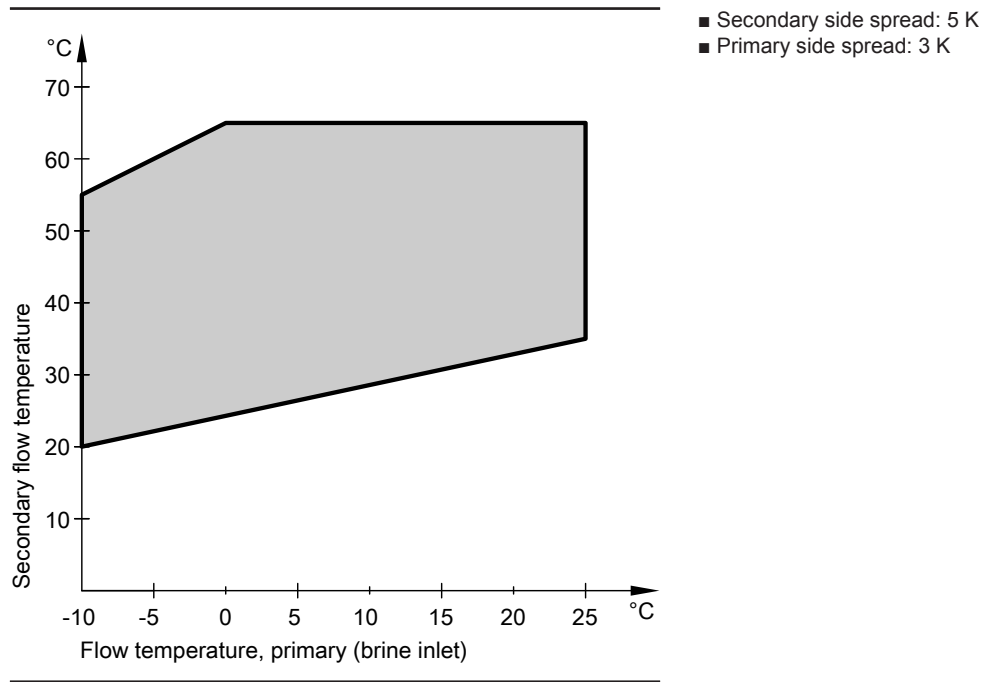

3

Curves, type BW, BWS

Type BW 301.B06, BWS 301.B06

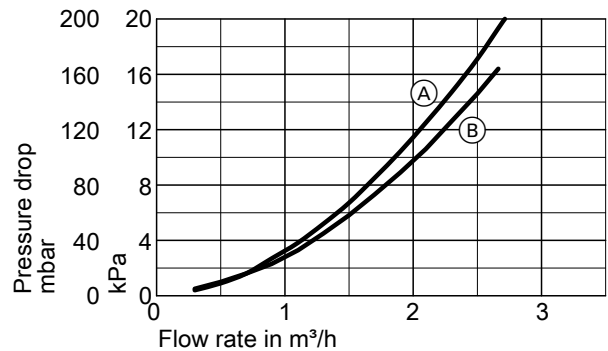
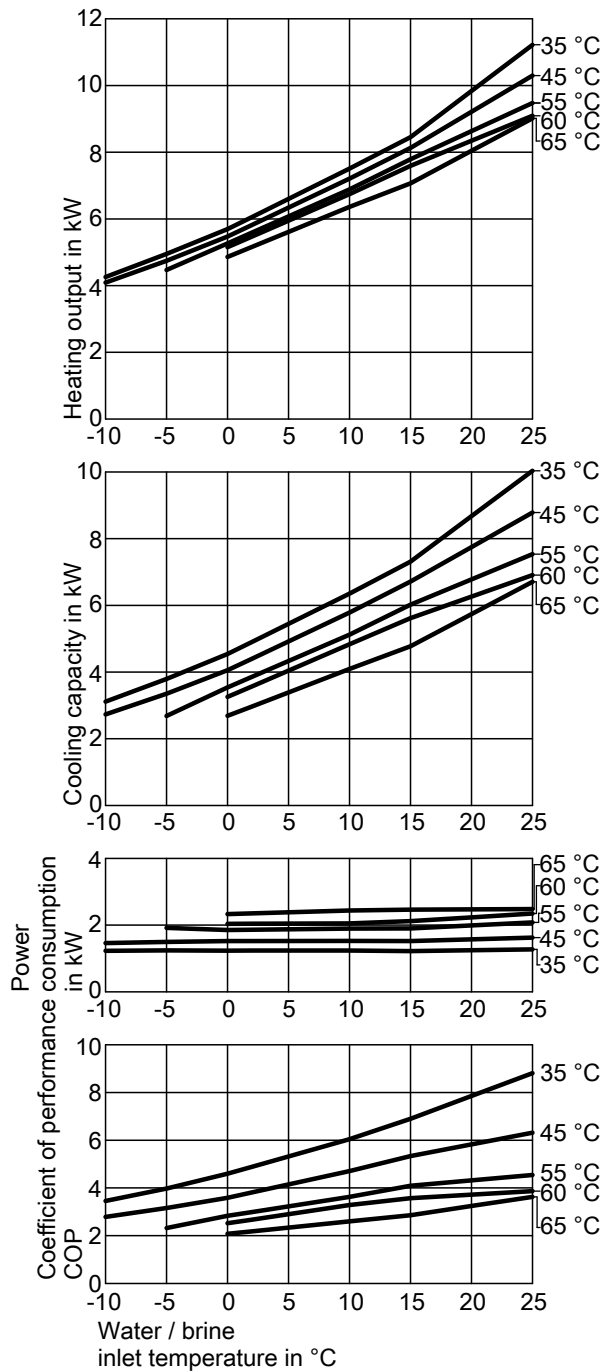

- (A) Secondary circuit
- (B) Primary circuit

Performance data

Operating point	W B	°C °C	35				
			-5	0	2	10	25
Heating output		kW	4.95	5.69	6.06	7.51	11.22
Cooling capacity		kW	3.80	4.54	4.91	6.35	10.04
Power consumption		kW	1.24	1.24	1.24	1.24	1.27
Coefficient of performance ε (COP)			3.98	4.60	4.89	6.05	8.81

Operating point	W B	°C °C	45				
			-5	0	2	10	25
Heating output		kW	4.75	5.47	5.82	7.21	10.30
Cooling capacity		kW	3.35	4.06	4.40	5.79	8.78
Power consumption		kW	1.50	1.52	1.52	1.53	1.63
Coefficient of performance ε (COP)			3.17	3.59	3.82	4.71	6.32

Operating point	W B	°C °C	55				
			-5	0	2	10	25
Heating output		kW	4.47	5.27	5.59	6.89	9.48
Cooling capacity		kW	2.69	3.54	3.86	5.12	7.54
Power consumption		kW	1.92	1.86	1.86	1.90	2.08
Coefficient of performance ε (COP)			2.33	2.84	3.00	3.63	4.55

Operating point	W B	°C °C	65			
			0	2	10	25
Heating output		kW	4.86	5.16	6.36	9.02
Cooling capacity		kW	2.69	2.97	4.09	6.71
Power consumption		kW	2.34	2.36	2.44	2.48
Coefficient of performance ε (COP)			2.08	2.19	2.61	3.63

Note

COP calculated with reference to EN 14511.

Performance characteristics are determined under the following conditions:

- New appliances with clean plate heat exchangers
- With high efficiency circulation pumps
- Primary circuit with Tyfocor heat transfer medium, 30 % by vol.
- Secondary circuit with water

Vitocal 300-G, type BW 301.B06 to B17, BWS 301.B06 to B17, BWC 301.B06 to B17 (cont.)

Type BW 301.B08, BWS 301.B08

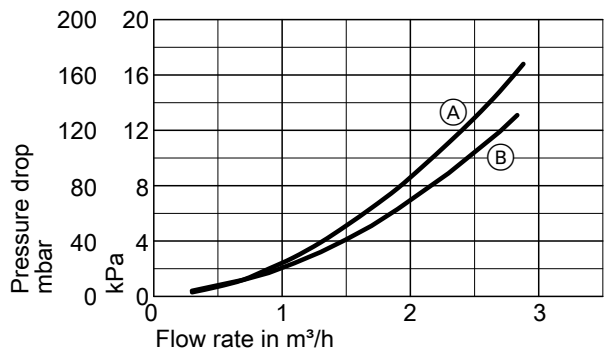
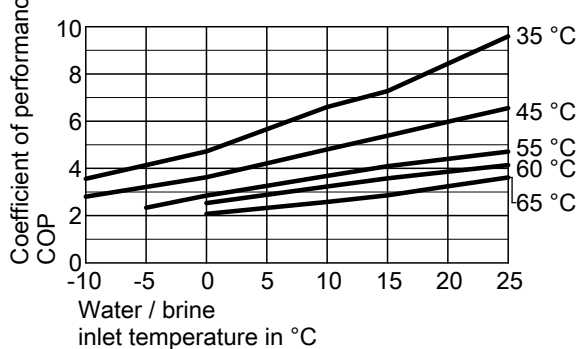
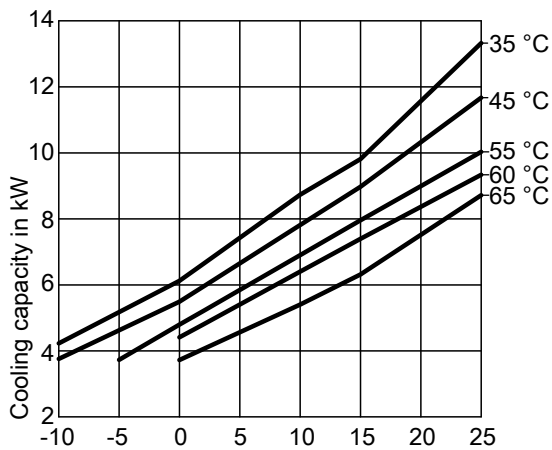
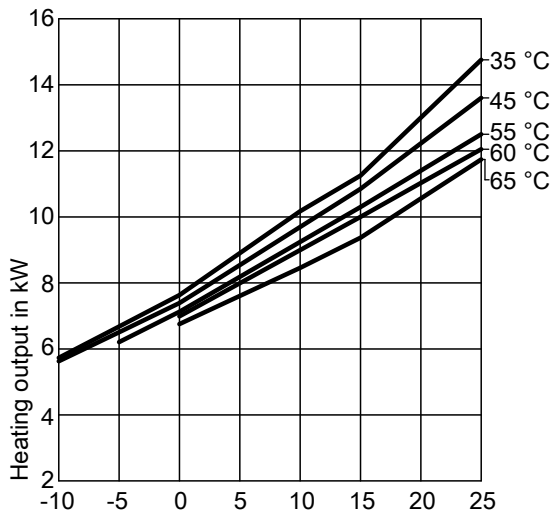

- (A) Secondary circuit
- (B) Primary circuit

Performance data

Operating point	W B	°C °C	35				
			-5	0	2	10	25
Heating output		kW	6.68	7.64	8.14	10.18	14.76
Cooling capacity		kW	5.18	6.13	6.65	8.74	13.32
Power consumption		kW	1.62	1.62	1.61	1.55	1.54
Coefficient of performance ε (COP)			4.13	4.71	5.08	6.58	9.57

Operating point	W B	°C °C	45				
			-5	0	2	10	25
Heating output		kW	6.51	7.39	7.85	9.70	13.60
Cooling capacity		kW	4.63	5.50	5.96	7.82	11.67
Power consumption		kW	2.03	2.04	2.04	2.03	2.08
Coefficient of performance ε (COP)			3.21	3.63	3.86	4.79	6.54

Operating point	W B	°C °C	55				
			-5	0	2	10	25
Heating output		kW	6.21	7.13	7.55	9.25	12.50
Cooling capacity		kW	3.74	4.80	5.22	6.91	10.03
Power consumption		kW	2.66	2.51	2.51	2.52	2.66
Coefficient of performance ε (COP)			2.33	2.84	3.01	3.68	4.70

Operating point	W B	°C °C	65			
			0	2	10	25
Heating output		kW	6.76	7.10	8.46	11.74
Cooling capacity		kW	3.73	4.07	5.41	8.72
Power consumption		kW	3.26	3.26	3.28	3.25
Coefficient of performance ε (COP)			2.07	2.18	2.58	3.61

Note

COP calculated with reference to EN 14511.

Performance characteristics are determined under the following conditions:

- New appliances with clean plate heat exchangers
- With high efficiency circulation pumps
- Primary circuit with Tyfocor heat transfer medium, 30 % by vol.
- Secondary circuit with water

Vitocal 300-G, type BW 301.B06 to B17, BWS 301.B06 to B17, BWC 301.B06 to B17 (cont.)

Type BW 301.B10, BWS 301.B10

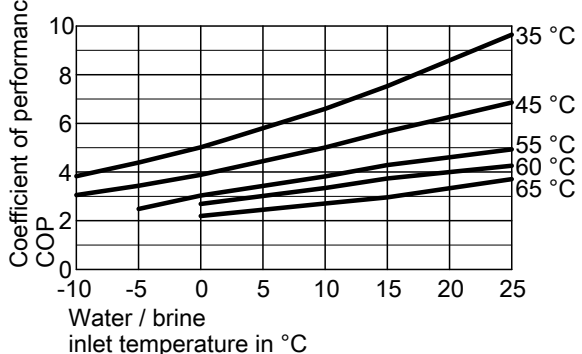
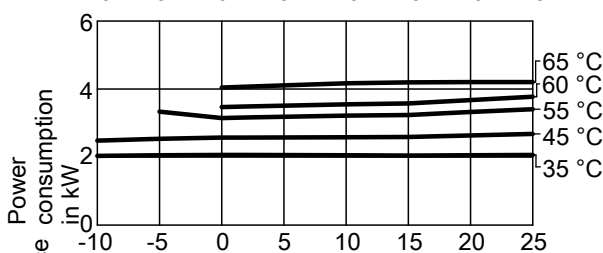
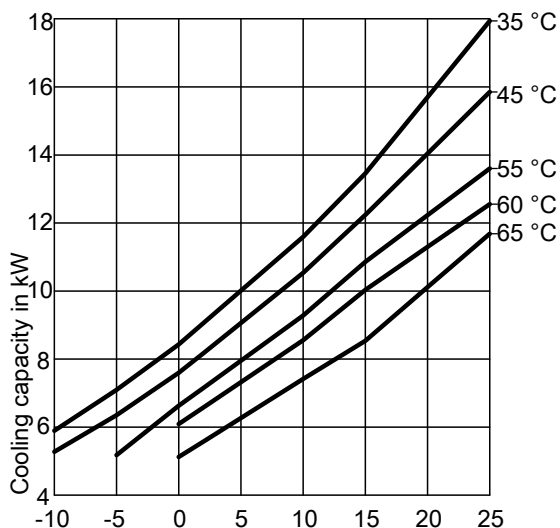
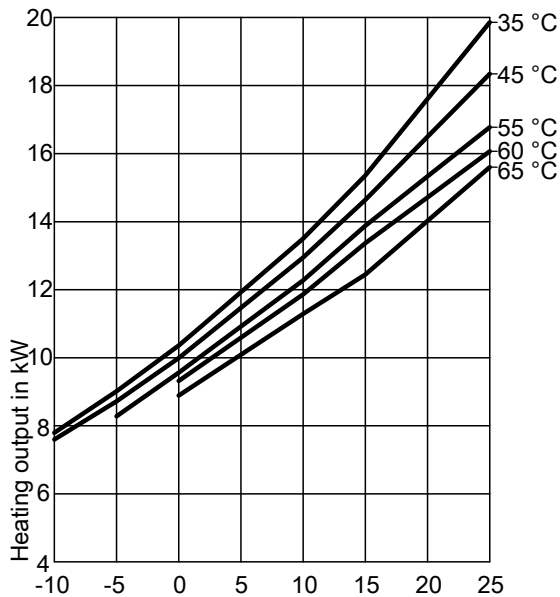

Note

COP calculated with reference to EN 14511.

Performance characteristics are determined under the following conditions:

- New appliances with clean plate heat exchangers
- With high efficiency circulation pumps
- Primary circuit with Tyfocor heat transfer medium, 30 % by vol.
- Secondary circuit with water

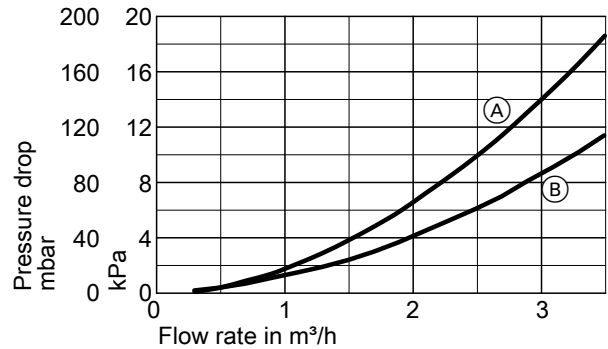

- (A) Secondary circuit
- (B) Primary circuit

Performance data

Operating point	W B	°C °C	35				
			-5	0	2	10	25
Heating output		kW	9.02	10.36	10.99	13.51	19.86
Cooling capacity		kW	7.10	8.43	9.07	11.60	17.94
Power consumption		kW	2.06	2.07	2.07	2.05	2.06
Coefficient of performance ε (COP)			4.38	5.01	5.32	6.58	9.63

Operating point	W B	°C °C	45				
			-5	0	2	10	25
Heating output		kW	8.72	9.99	10.58	12.95	18.35
Cooling capacity		kW	6.36	7.60	8.19	10.54	15.85
Power consumption		kW	2.54	2.57	2.58	2.59	2.68
Coefficient of performance ε (COP)			3.43	3.88	4.11	5.00	6.84

Operating point	W B	°C °C	55				
			-5	0	2	10	25
Heating output		kW	8.28	9.56	10.11	12.28	16.78
Cooling capacity		kW	5.18	6.63	7.16	9.29	13.61
Power consumption		kW	3.33	3.15	3.17	3.22	3.41
Coefficient of performance ε (COP)			2.48	3.03	3.19	3.82	4.92

Operating point	W B	°C °C	65			
			0	2	10	25
Heating output		kW	8.89	9.37	11.29	15.61
Cooling capacity		kW	5.13	5.59	7.42	11.69
Power consumption		kW	4.04	4.07	4.17	4.21
Coefficient of performance ε (COP)			2.20	2.30	2.71	3.71

Type BW 301.B13, BWS 301.B13

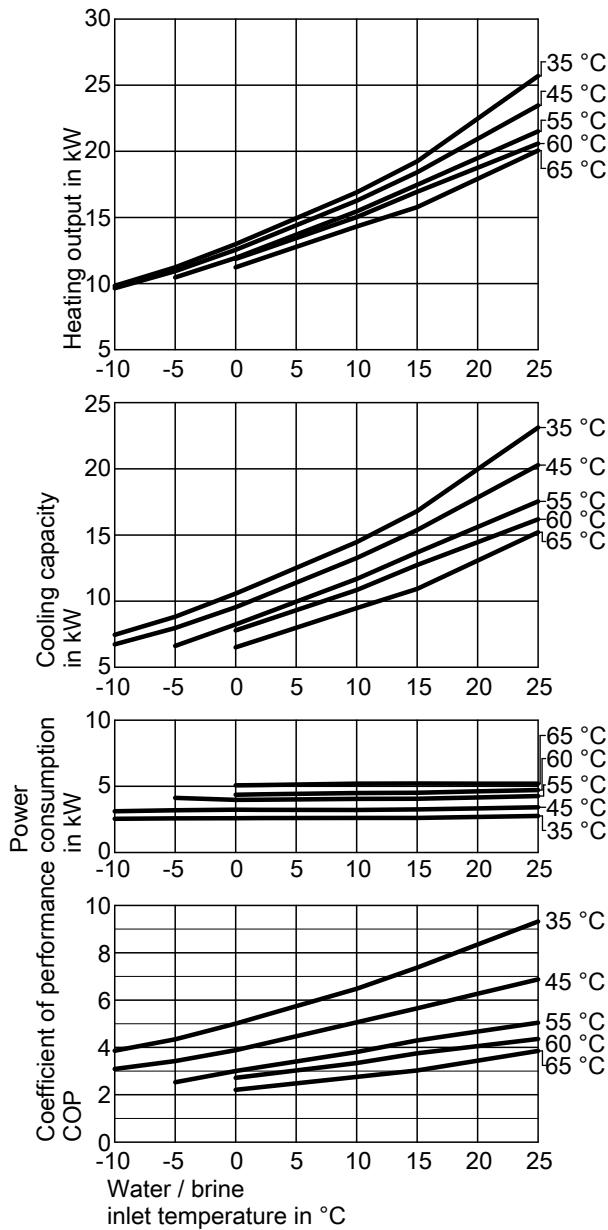

Note
COP calculated with reference to EN 14511.

Performance characteristics are determined under the following conditions:

- New appliances with clean plate heat exchangers
- With high efficiency circulation pumps
- Primary circuit with Tyfocor heat transfer medium, 30 % by vol.
- Secondary circuit with water

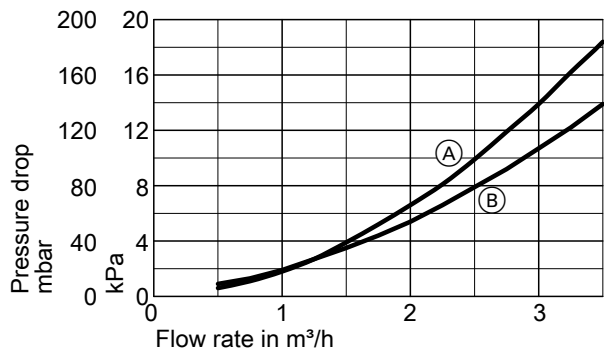

- (A) Secondary circuit
- (B) Primary circuit

Performance data

Operating point	W B	°C °C	35				
			-5	0	2	10	25
Heating output	kW		11.23	12.99	13.77	16.89	25.69
Cooling capacity	kW		8.82	10.57	11.35	14.46	23.12
Power consumption	kW		2.59	2.60	2.60	2.61	2.76
Coefficient of performance ε (COP)			4.34	5.00	5.29	6.46	9.30

Operating point	W B	°C °C	45				
			-5	0	2	10	25
Heating output	kW		10.94	12.55	13.29	16.26	23.46
Cooling capacity	kW		7.97	9.54	10.28	13.27	20.28
Power consumption	kW		3.20	3.24	3.23	3.22	3.42
Coefficient of performance ε (COP)			3.43	3.88	4.11	5.05	6.86

Operating point	W B	°C °C	55				
			-5	0	2	10	25
Heating output	kW		10.46	11.94	12.64	15.46	21.51
Cooling capacity	kW		6.62	8.24	8.93	11.68	17.54
Power consumption	kW		4.14	3.98	3.99	4.06	4.27
Coefficient of performance ε (COP)			2.53	3.00	3.16	3.80	5.04

Operating point	W B	°C °C	65			
			0	2	10	25
Heating output	kW		11.23	11.85	14.32	20.05
Cooling capacity	kW		6.51	7.10	9.48	15.21
Power consumption	kW		5.08	5.10	5.21	5.21
Coefficient of performance ε (COP)			2.21	2.32	2.75	3.85

Vitocal 300-G, type BW 301.B06 to B17, BWS 301.B06 to B17, BWC 301.B06 to B17 (cont.)

Type BW 301.B17, BWS 301.B17

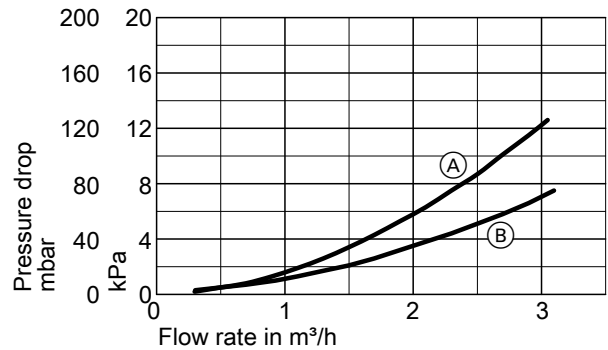
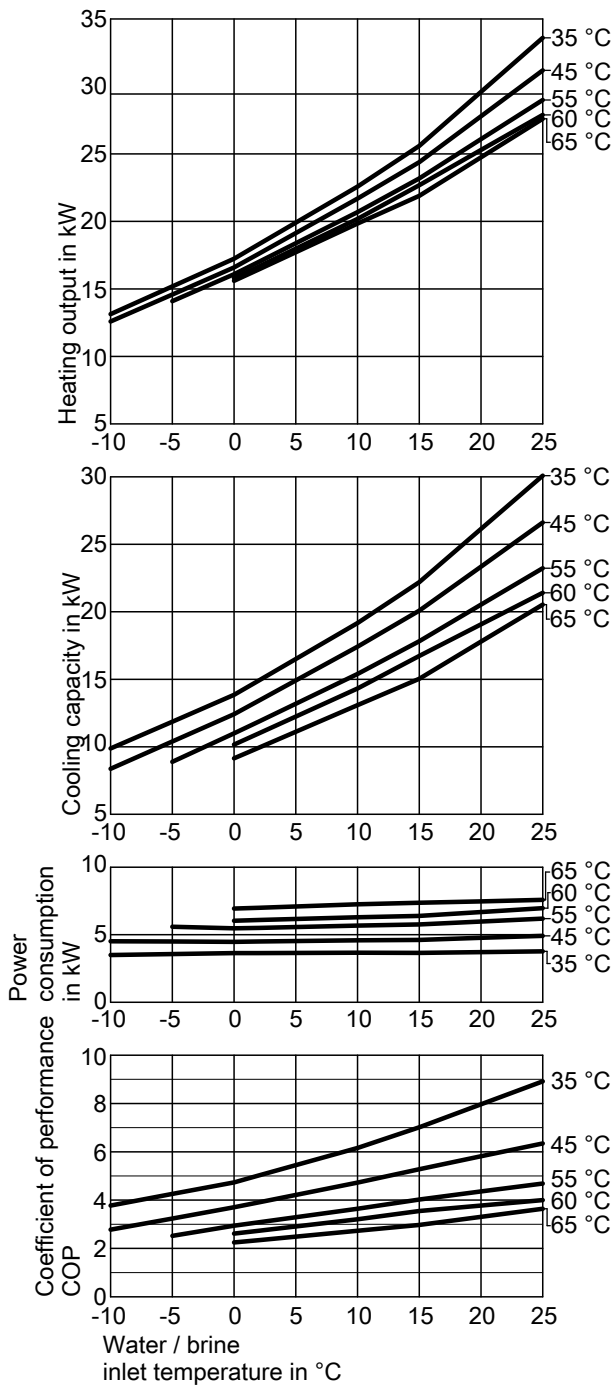

- (A) Secondary circuit
- (B) Primary circuit

Performance data

Operating point	W B	°C °C	35				
			-5	0	2	10	25
Heating output	kW		15.19	17.24	18.31	22.59	33.59
Cooling capacity	kW		11.87	13.85	14.91	19.17	30.08
Power consumption	kW		3.58	3.65	3.65	3.68	3.78
Coefficient of performance ϵ (COP)			4.25	4.73	5.01	6.15	8.90

Operating point	W B	°C °C	45				
			-5	0	2	10	25
Heating output	kW		14.59	16.59	17.61	21.69	31.19
Cooling capacity	kW		10.40	12.42	13.42	17.42	26.61
Power consumption	kW		4.51	4.49	4.51	4.60	4.93
Coefficient of performance ϵ (COP)			3.24	3.70	3.90	4.72	6.33

Operating point	W B	°C °C	55				
			-5	0	2	10	25
Heating output	kW		14.10	16.09	17.01	20.69	28.99
Cooling capacity	kW		8.89	11.00	11.88	15.40	23.23
Power consumption	kW		5.60	5.48	5.52	5.69	6.20
Coefficient of performance ϵ (COP)			2.52	2.94	3.08	3.64	4.68

Operating point	W B	°C °C	65			
			0	2	10	25
Heating output	kW		15.60	16.45	19.85	27.60
Cooling capacity	kW		9.15	9.94	13.10	20.54
Power consumption	kW		6.94	7.01	7.26	7.59
Coefficient of performance ϵ (COP)			2.25	2.35	2.73	3.64

Note

COP calculated with reference to EN 14511.

Performance characteristics are determined under the following conditions:

- New appliances with clean plate heat exchangers
- With high efficiency circulation pumps
- Primary circuit with Tyfocor heat transfer medium, 30 % by vol.
- Secondary circuit with water

Curves, type BWC

Type BWC 301.B06

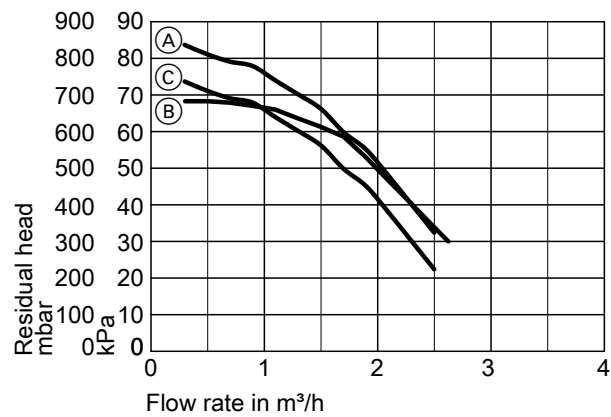
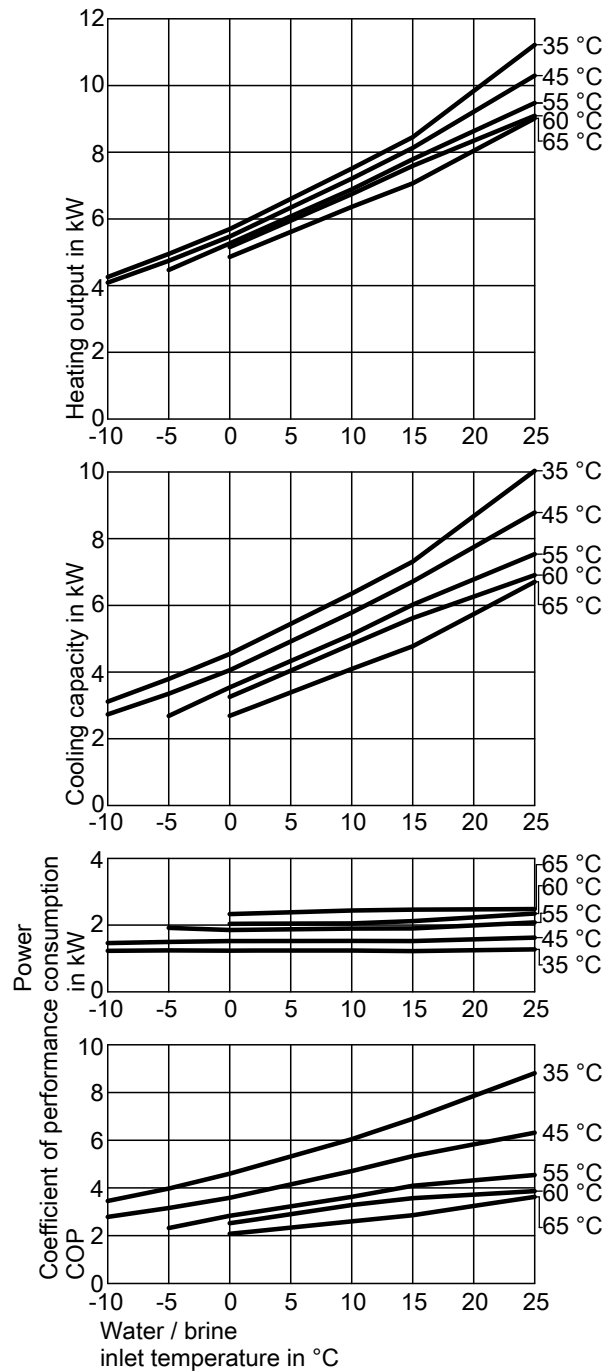

- (A) Secondary circuit (Grundfos UPML 25-85 PWM)
- (B) Primary circuit (Wilo Yonos PARA GT 25/7.5 PWM)
- (C) Circulation pump for cylinder heating (Grundfos UPM2 25-75 PWM)

Performance data

Operating point	W B	°C °C	35				
			-5	0	2	10	25
Heating output		kW	4.95	5.69	6.06	7.51	11.22
Cooling capacity		kW	3.80	4.54	4.91	6.35	10.04
Power consumption		kW	1.24	1.24	1.24	1.24	1.27
Coefficient of performance ε (COP)			3.98	4.60	4.89	6.05	8.81

Operating point	W B	°C °C	45				
			-5	0	2	10	25
Heating output		kW	4.75	5.47	5.82	7.21	10.30
Cooling capacity		kW	3.35	4.06	4.40	5.79	8.78
Power consumption		kW	1.50	1.52	1.52	1.53	1.63
Coefficient of performance ε (COP)			3.17	3.59	3.82	4.71	6.32

Operating point	W B	°C °C	55				
			-5	0	2	10	25
Heating output		kW	4.47	5.27	5.59	6.89	9.48
Cooling capacity		kW	2.69	3.54	3.86	5.12	7.54
Power consumption		kW	1.92	1.86	1.86	1.90	2.08
Coefficient of performance ε (COP)			2.33	2.84	3.00	3.63	4.55

Operating point	W B	°C °C	65			
			0	2	10	25
Heating output		kW	4.86	5.16	6.36	9.02
Cooling capacity		kW	2.69	2.97	4.09	6.71
Power consumption		kW	2.34	2.36	2.44	2.48
Coefficient of performance ε (COP)			2.08	2.19	2.61	3.63

Note
COP calculated with reference to EN 14511.

Performance characteristics are determined under the following conditions:

- New appliances with clean plate heat exchangers
- Primary circuit with Tyfocor heat transfer medium, 30 % by vol.
- Secondary circuit with water

Type BWC 301.B08

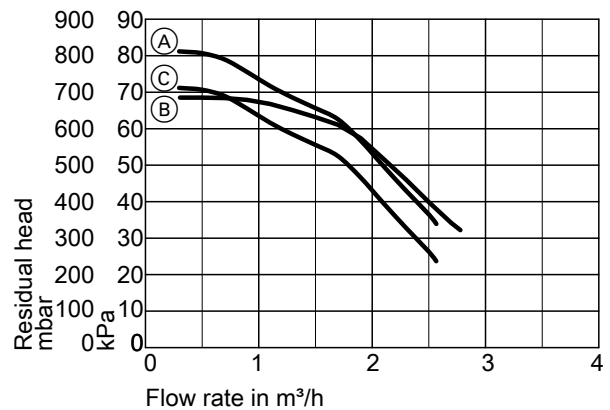
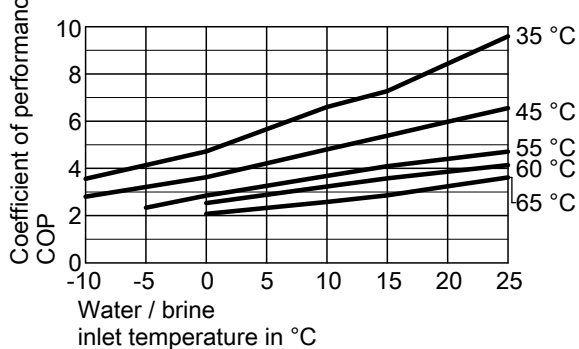
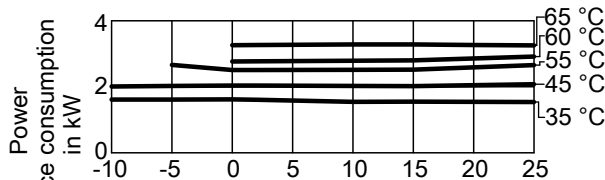
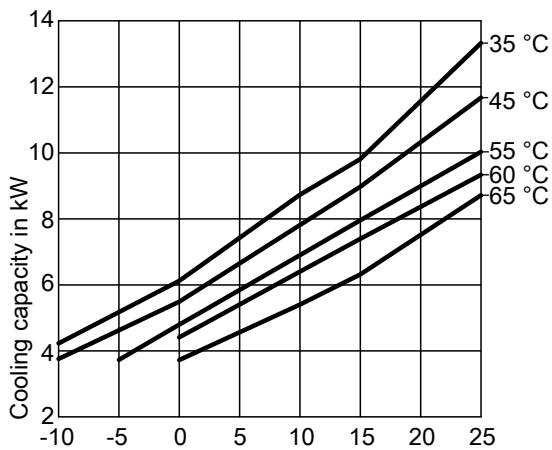
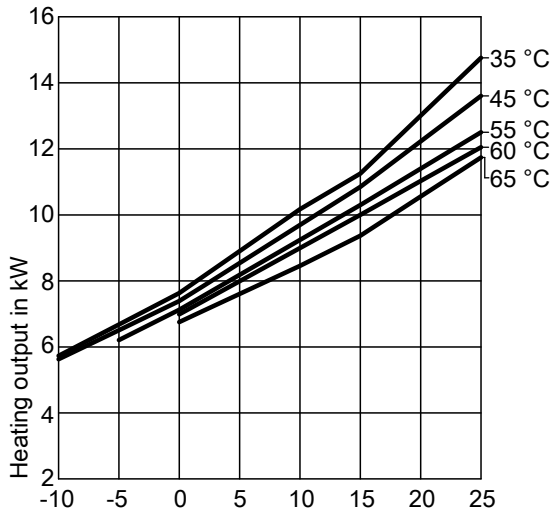

- (A) Secondary circuit (Grundfos UPML 25-85 PWM)
- (B) Primary circuit (Wilo Yonos PARA GT 25/7.5 PWM)
- (C) Circulation pump for cylinder heating (Grundfos UPM2 25-75 PWM)

Performance data

Operating point	W B	°C °C	35				
			-5	0	2	10	25
Heating output		°C	6.68	7.64	8.14	10.18	14.76
Cooling capacity		°C	5.18	6.13	6.65	8.74	13.32
Power consumption		°C	1.62	1.62	1.61	1.55	1.54
Coefficient of performance ε (COP)		°C	4.13	4.71	5.08	6.58	9.57

Operating point	W B	°C °C	45				
			-5	0	2	10	25
Heating output		°C	6.51	7.39	7.85	9.70	13.60
Cooling capacity		°C	4.63	5.50	5.96	7.82	11.67
Power consumption		°C	2.03	2.04	2.04	2.03	2.08
Coefficient of performance ε (COP)		°C	3.21	3.63	3.86	4.79	6.54

Operating point	W B	°C °C	55				
			-5	0	2	10	25
Heating output		°C	6.21	7.13	7.55	9.25	12.50
Cooling capacity		°C	3.74	4.80	5.22	6.91	10.03
Power consumption		°C	2.66	2.51	2.51	2.52	2.66
Coefficient of performance ε (COP)		°C	2.33	2.84	3.01	3.68	4.70

Operating point	W B	°C °C	65			
			0	2	10	25
Heating output		°C	6.76	7.10	8.46	11.74
Cooling capacity		°C	3.73	4.07	5.41	8.72
Power consumption		°C	3.26	3.26	3.28	3.25
Coefficient of performance ε (COP)		°C	2.07	2.18	2.58	3.61

Note

COP calculated with reference to EN 14511.

Performance characteristics are determined under the following conditions:

- New appliances with clean plate heat exchangers
- Primary circuit with Tyfocor heat transfer medium, 30 % by vol.
- Secondary circuit with water

5822541

Type BWC 301.B10

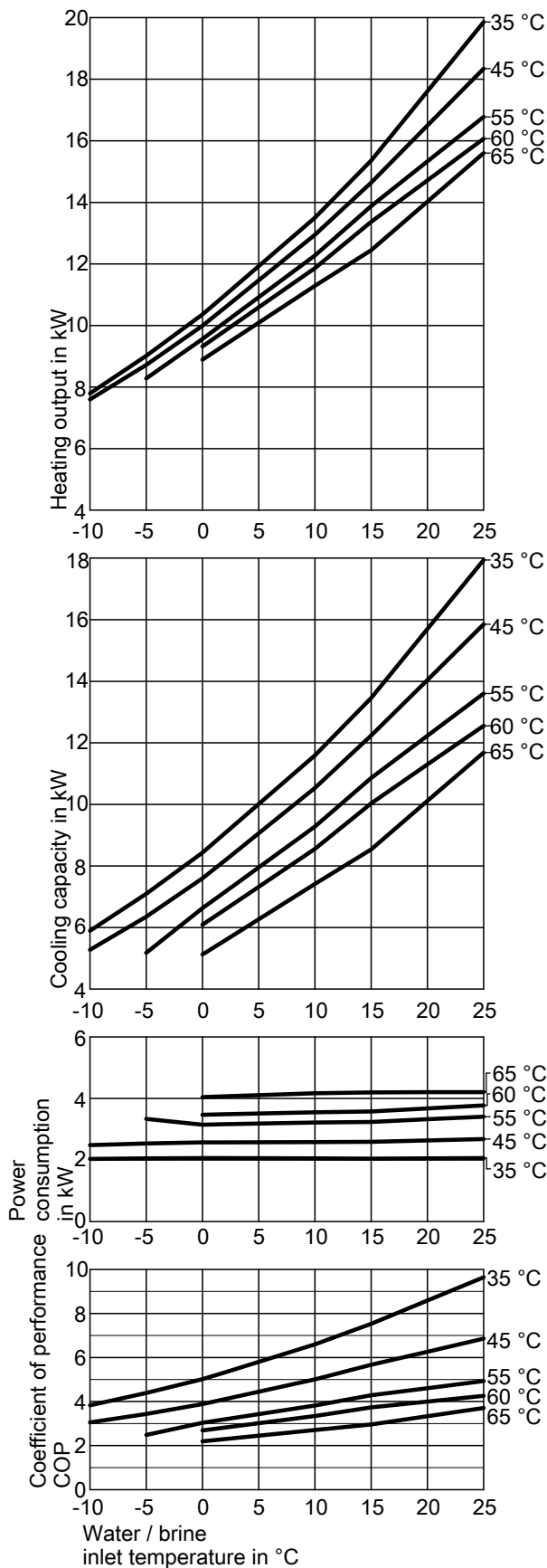

Note

COP calculated with reference to EN 14511.

Performance characteristics are determined under the following conditions:

- New appliances with clean plate heat exchangers
- Primary circuit with Tyfocor heat transfer medium, 30 % by vol.
- Secondary circuit with water

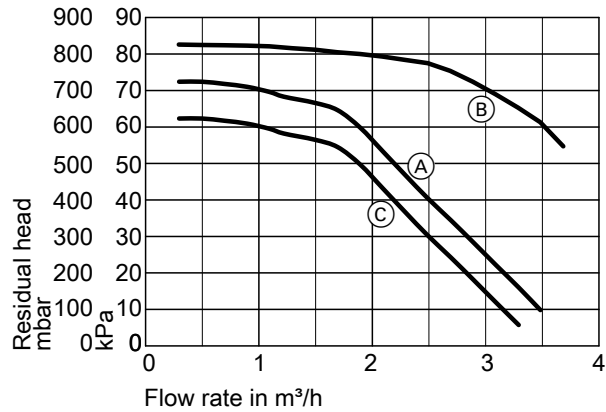

- (A) Secondary circuit (Grundfos UPML 25-85 PWM)
- (B) Primary circuit (Wilo Yonos PARA GT 25/7.5 PWM)
- (C) Circulation pump for cylinder heating (Grundfos UPM2 25-75 PWM)

Performance data

Operating point	W B	°C °C	35				
			-5	0	2	10	25
Heating output		kW	9.02	10.36	10.99	13.51	19.86
Cooling capacity		kW	7.10	8.43	9.07	11.60	17.94
Power consumption		kW	2.06	2.07	2.07	2.05	2.06
Coefficient of performance ε (COP)			4.38	5.01	5.32	6.58	9.63

Operating point	W B	°C °C	45				
			-5	0	2	10	25
Heating output		kW	8.72	9.99	10.58	12.95	18.35
Cooling capacity		kW	6.36	7.60	8.19	10.54	15.85
Power consumption		kW	2.54	2.57	2.58	2.59	2.68
Coefficient of performance ε (COP)			3.43	3.88	4.11	5.00	6.84

Operating point	W B	°C °C	55				
			-5	0	2	10	25
Heating output		kW	8.28	9.56	10.11	12.28	16.78
Cooling capacity		kW	5.18	6.63	7.16	9.29	13.61
Power consumption		kW	3.33	3.15	3.17	3.22	3.41
Coefficient of performance ε (COP)			2.48	3.03	3.19	3.82	4.92

Operating point	W B	°C °C	65			
			0	2	10	25
Heating output		kW	8.89	9.37	11.29	15.61
Cooling capacity		kW	5.13	5.59	7.42	11.69
Power consumption		kW	4.04	4.07	4.17	4.21
Coefficient of performance ε (COP)			2.20	2.30	2.71	3.71

Type BWC 301.B13

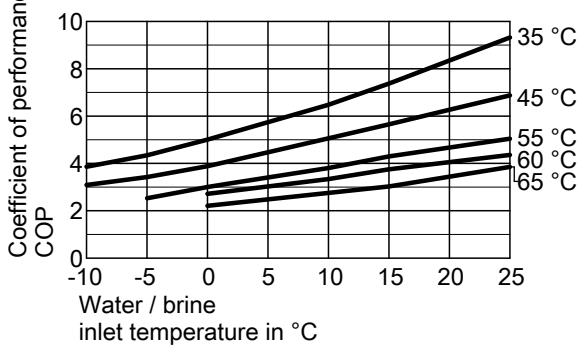
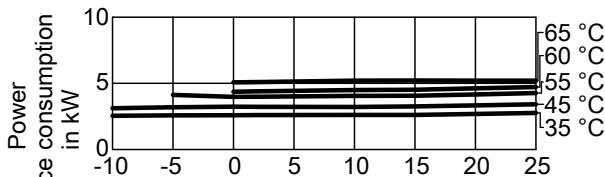
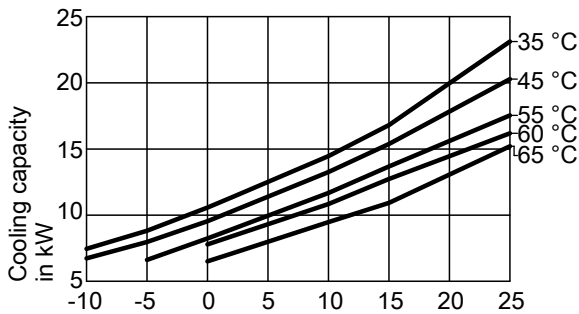
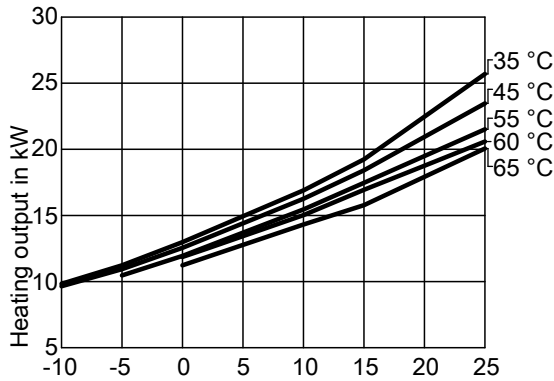

Note

COP calculated with reference to EN 14511.

Performance characteristics are determined under the following conditions:

- New appliances with clean plate heat exchangers
- Primary circuit with Tyfocor heat transfer medium, 30 % by vol.
- Secondary circuit with water

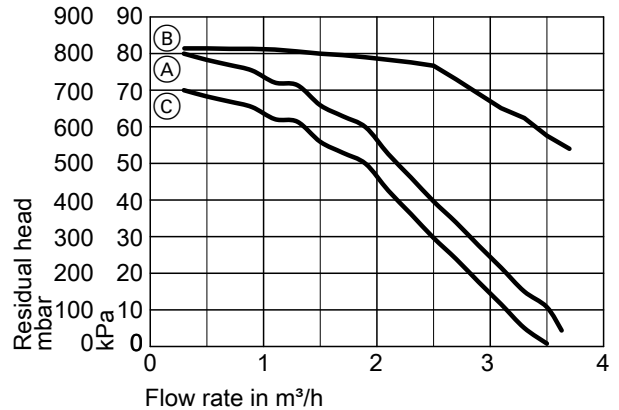

- (A) Secondary circuit (Grundfos UPML 25-85 PWM)
- (B) Primary circuit (Wilo Stratos PARA 25/1-8 PWM)
- (C) Circulation pump for cylinder heating (Grundfos UPM2 25-75 PWM)

Performance data

Operating point	W B	°C °C	35				
			-5	0	2	10	25
Heating output	kW		11.23	12.99	13.77	16.89	25.69
Cooling capacity	kW		8.82	10.57	11.35	14.46	23.12
Power consumption	kW		2.59	2.60	2.60	2.61	2.76
Coefficient of performance ε (COP)			4.34	5.00	5.29	6.46	9.30

Operating point	W B	°C °C	45				
			-5	0	2	10	25
Heating output	kW		10.94	12.55	13.29	16.26	23.46
Cooling capacity	kW		7.97	9.54	10.28	13.27	20.28
Power consumption	kW		3.20	3.24	3.23	3.22	3.42
Coefficient of performance ε (COP)			3.43	3.88	4.11	5.05	6.86

Operating point	W B	°C °C	55				
			-5	0	2	10	25
Heating output	kW		10.46	11.94	12.64	15.46	21.51
Cooling capacity	kW		6.62	8.24	8.93	11.68	17.54
Power consumption	kW		4.14	3.98	3.99	4.06	4.27
Coefficient of performance ε (COP)			2.53	3.00	3.16	3.80	5.04

Operating point	W B	°C °C	65			
			0	2	10	25
Heating output	kW		11.23	11.85	14.32	20.05
Cooling capacity	kW		6.51	7.10	9.48	15.21
Power consumption	kW		5.08	5.10	5.21	5.21
Coefficient of performance ε (COP)			2.21	2.32	2.75	3.85

Type BWC 301.B17

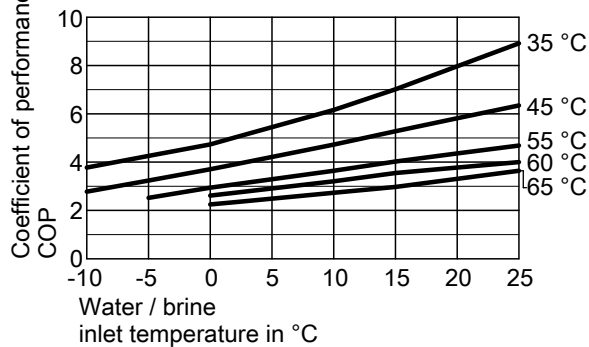
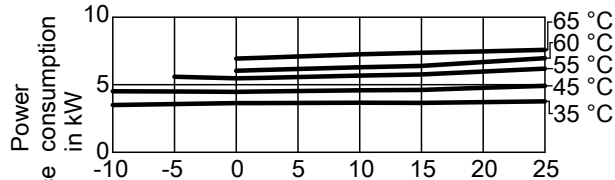
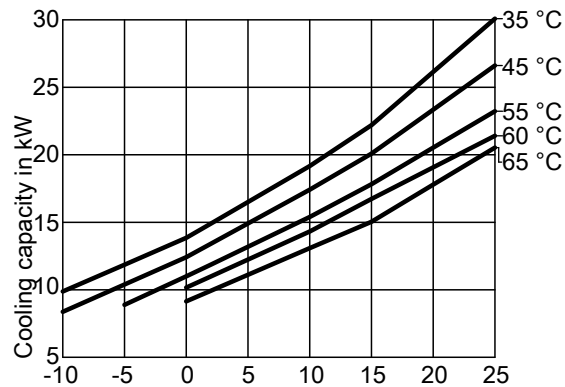
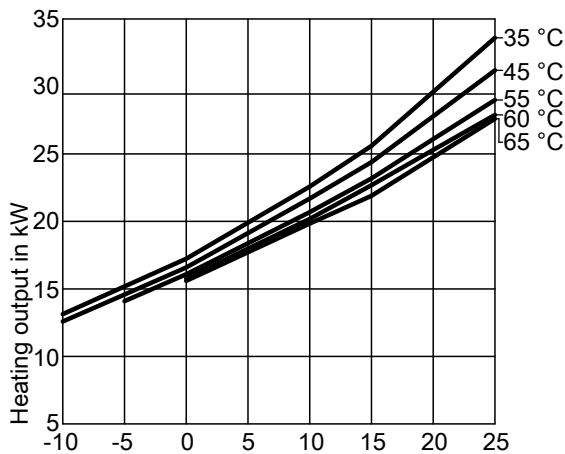

Note
COP calculated with reference to EN 14511.

Performance characteristics are determined under the following conditions:

- New appliances with clean plate heat exchangers
- Primary circuit with Tyfocor heat transfer medium, 30 % by vol.
- Secondary circuit with water

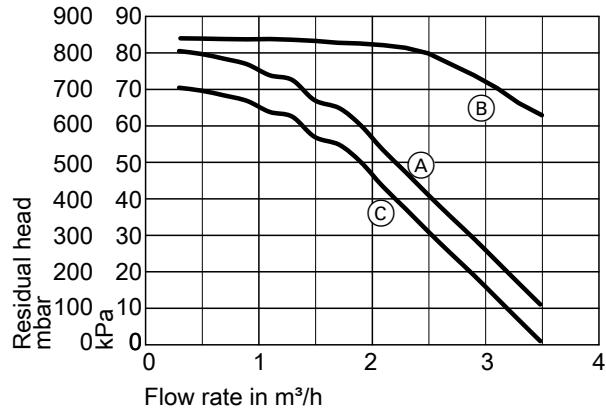

- (A) Secondary circuit (Grundfos UPML 25-85 PWM)
- (B) Primary circuit (Wilo Stratos PARA 25/1-8 PWM)
- (C) Circulation pump for cylinder heating (Grundfos UPM2 25-75 PWM)

Performance data

Operating point	W B	°C °C	35				
			-5	0	2	10	25
Heating output	kW		15.19	17.24	18.31	22.59	33.59
Cooling capacity	kW		11.87	13.85	14.91	19.17	30.08
Power consumption	kW		3.58	3.65	3.65	3.68	3.78
Coefficient of performance ε (COP)			4.25	4.73	5.01	6.15	8.90

Operating point	W B	°C °C	45				
			-5	0	2	10	25
Heating output	kW		14.59	16.59	17.61	21.69	31.19
Cooling capacity	kW		10.40	12.42	13.42	17.42	26.61
Power consumption	kW		4.51	4.49	4.51	4.60	4.93
Coefficient of performance ε (COP)			3.24	3.70	3.90	4.72	6.33

Operating point	W B	°C °C	55				
			-5	0	2	10	25
Heating output	kW		14.10	16.09	17.01	20.69	28.99
Cooling capacity	kW		8.89	11.00	11.88	15.40	23.23
Power consumption	kW		5.60	5.48	5.52	5.69	6.20
Coefficient of performance ε (COP)			2.52	2.94	3.08	3.64	4.68

Operating point	W B	°C °C	65			
			0	2	10	25
Heating output	kW		15.60	16.45	19.85	27.60
Cooling capacity	kW		9.15	9.94	13.10	20.54
Power consumption	kW		6.94	7.01	7.26	7.59
Coefficient of performance ε (COP)			2.25	2.35	2.73	3.64

4.1 Product description

Benefits of type BW, BWS

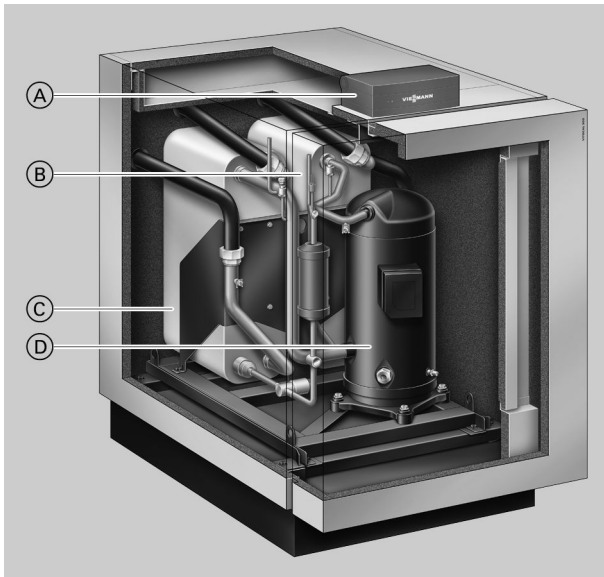

- (A) Vitotronic 200 weather-compensated, digital heat pump control unit
- (B) Condenser
- (C) Evaporator
- (D) Hermetically sealed Compliant scroll compressor

- Low running costs thanks to a high COP to EN 14511: Up to 4.8 (B0/W35)
- Mono mode operation for central heating and DHW heating
- Maximum flow temperatures of up to 60 °C for high DHW convenience
- Low noise and vibration levels thanks to sound-optimised appliance design – sound power level < 48 dB(A)
- Low running costs with the highest level of efficiency at any operating point through the innovative Refrigerant Cycle Diagnostic (RCD) system with electronic expansion valve (EEV)
- With the 2-stage version (type BW+BWS):
Highly flexible due to option of combining modules of different outputs
Easier handling through smaller and lighter modules

Only type BW:

- Easy-to-use Vitotronic control unit with plain text and graphic display for weather-compensated heating mode and natural or active cooling
- Higher output can be achieved through cascade arrangement: 21.2 to 428.0 kW
- Optimised utilisation of power generated by an on-site photovoltaic system
- Web-enabled through Vitoconnect (accessories) for operation and service via Viessmann apps

Delivered condition, type BW

- Complete compact heat pump as a single stage heat pump or as stage 1 (master) of a 2-stage heat pump
- Adjustable anti-vibration feet
- Weather-compensated Vitotronic 200 heat pump control unit with outside temperature sensor
- Electronic starting current limiter and integral phase monitor

Delivered condition, type BWS

- Compact heat pump as stage 2 (slave)
- Adjustable anti-vibration feet
- Electrical connecting cable for connection to stage 1 (master).
- Electronic starting current limiter

4.2 Specification

Specification for brine/water heat pumps

Type BW/BWS		301.A21	301.A29	301.A45
Performance data to EN 14511 (B0/W35, 5 K spread)				
Rated heating output	kW	21.2	28.8	42.8
Cooling capacity	kW	17.0	23.3	34.2
Power consumption	kW	4.48	5.96	9.28
Coefficient of performance (COP)		4.73	4.83	4.60
Brine (primary circuit)				
Capacity	l	6.5	8.5	11.5
Minimum flow rate	l/h	3300	4200	6500
Pressure drop at minimum flow rate	mbar	70	95	154
	kPa	7	9.5	15.4
Max. flow temperature (brine inlet)	°C	25	25	25
Min. flow temperature (brine inlet)	°C	-10	-10	-10
Heating water (secondary circuit)				
Capacity	l	6.5	8.5	11.5
Nominal flow rate	l/h	3740	5050	7360
Pressure drop at nominal flow rate	mbar	120	130	210
	kPa	12	13	21
Minimum flow rate	l/h	1900	2550	3700
Pressure drop at minimum flow rate	mbar	38	38	65
	kPa	3.8	3.8	6.5
Max. flow temperature	°C	60	60	60
Electrical values, heat pump				
Rated voltage, compressor	V	3/PE 400 V/50 Hz		
Rated current, compressor	A	16	22	34
Cos φ		0.8	0.8	0.8
Starting current, compressor (with starting current limiter)	A	< 30	41	47
Starting current, compressor with stalled armature	A	95	118	174
Compressor MCB/fuse protection	A	1 x C16A 3-pole	1 x C25A 3-pole	1 x C40A 3-pole
Protection class		I	I	I
Electrical values, heat pump control unit				
Rated voltage, control unit/PCB	V	1/N/PE 230 V/50 Hz		
MCB/fuse protection, control unit/PCB		1 x B16A		
MCB/fuse, control unit/PCB	A	6.3 A (slow)/250 V		
IP rating		IP 20	IP 20	IP 20
Power consumption				
Max. power consumption, heat pump control unit/PCB, heat pump stage 1 (type BW 301.A)	W	25	25	25
Max. power consumption, PCB, heat pump stage 2 (type BWS 301.A)		20	20	20
Power consumption, heat pump control unit/PCB, stages 1 and 2	W	45	45	45
Refrigerant circuit				
Refrigerant		R410A	R410A	R410A
– Refrigerant charge	kg	4.7	6.2	7.7
– Global warming potential (GWP) ^{*4}		1924	1924	1924
– CO ₂ equivalent	t	9.0	11.9	14.8
Permiss. operating pressure, high pressure side	bar	43	43	43
	MPa	4.3	4.3	4.3
Permiss. operating pressure, low pressure side	bar	28	28	28
	MPa	2.8	2.8	2.8
Compressor	Type	Hermetically sealed scroll compressor		
Oil in compressor	Type	Emkarate RL32 3MAF		
Quantity of oil in compressor	l	2.65	3.25	3.38
Permiss. operating pressure				
Primary circuit	bar	3	3	3
	MPa	0.3	0.3	0.3
Secondary circuit	bar	3	3	3
	MPa	0.3	0.3	0.3

^{*4} Based on the Fifth Assessment Report of the Intergovernmental Panel on Climate Change (IPCC).

Vitocal 300-G, type BW 301.A21 to A45, BWS 301.A21 to A45 (cont.)

Type BW/BWS		301.A21	301.A29	301.A45
Dimensions				
Total length	mm	1085	1085	1085
Total width	mm	780	780	780
Total height without programming unit	mm	1074	1074	1074
Total height (programming unit pivoted up, type BW 301.A only)	mm	1267	1267	1267
Weight				
Heat pump stage 1 (type BW 301.A)	kg	245	272	298
Heat pump stage 2 (type BWS 301.A)	kg	240	267	293
Connections (male thread)				
Primary circuit flow/return	G	2	2	2
Secondary circuit flow/return	G	2	2	2
Sound power (measured with reference to EN 12102/ EN ISO 9614-2)				
Weighted total sound power level for $B0^{\pm 3} K/W35^{\pm 5} K$				
– At rated heating output	dB(A)	42	48	46
Energy efficiency class to EU Regulation no. 813/2013				
Heating, average climatic conditions				
– Low temperature applications (W35)		A ⁺⁺	A ⁺⁺	A ⁺⁺
– Medium temperature applications (W55)		A ⁺⁺	A ⁺⁺	A ⁺⁺
Performance data as per EU Regulation no. 813/2013 (average climatic conditions)				
Low temperature applications (W35)				
– Energy efficiency η_s	%	201	211	199
– Rated heating output P_{rated}	kW	24	33	49
– Seasonal coefficient of performance (SCOP)		5.23	5.48	5.18
Medium temperature applications (W55)				
– Energy efficiency η_s	%	140	138	138
– Rated heating output P_{rated}	kW	22	30	45
– Seasonal coefficient of performance (SCOP)		3.70	3.65	3.65

Specification for water/water heat pumps

Type BW/BWS in conjunction with conversion kit for water/water heat pump		301.A21	301.A29	301.A45
Performance data to EN 14511 (W10/W35, 5 K spread)				
Rated heating output	kW	28.1	37.1	58.9
Cooling capacity	kW	23.7	31.4	48.9
Power consumption	kW	4.73	6.2	10.7
Coefficient of performance ϵ (COP)		5.94	6.00	5.50
Brine (primary intermediate circuit)				
Content	l	6.5	8.5	11.5
Minimum flow rate	l/h	5200	7200	10600
Pressure drop at minimum flow rate	mbar	170	260	370
	kPa	17	26	37
Max. flow temperature (brine inlet)	°C	25	25	25
Min. flow temperature (brine inlet)	°C	7.5	7.5	7.5
Heating water (secondary circuit)				
Content	l	6.5	8.5	11.5
Minimum flow rate	l/h	2420	3200	5100
Pressure drop at minimum flow rate	mbar	50	55	110
	kPa	5	5.5	11
Max. flow temperature	°C	60	60	60

Note

Further specifications: See "Specification for brine/water heat pumps"

Vitocal 300-G, type BW 301.A21 to A45, BWS 301.A21 to A45 (cont.)

Dimensions for type BW 301.A21 to A45, BWS 301.A21 to A45

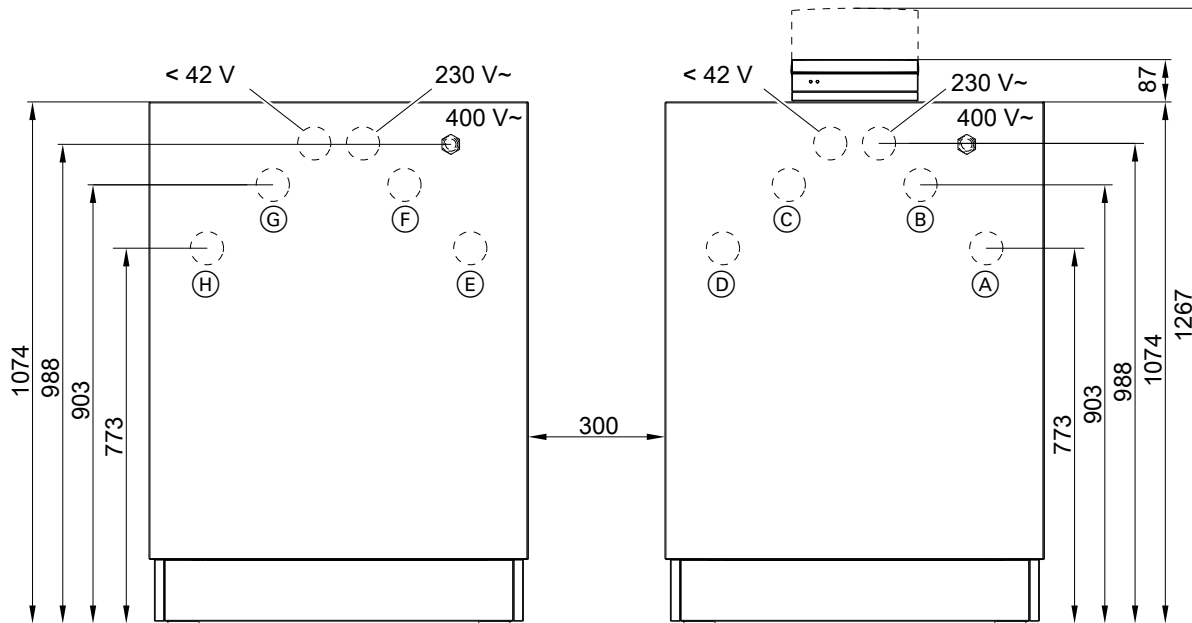

4

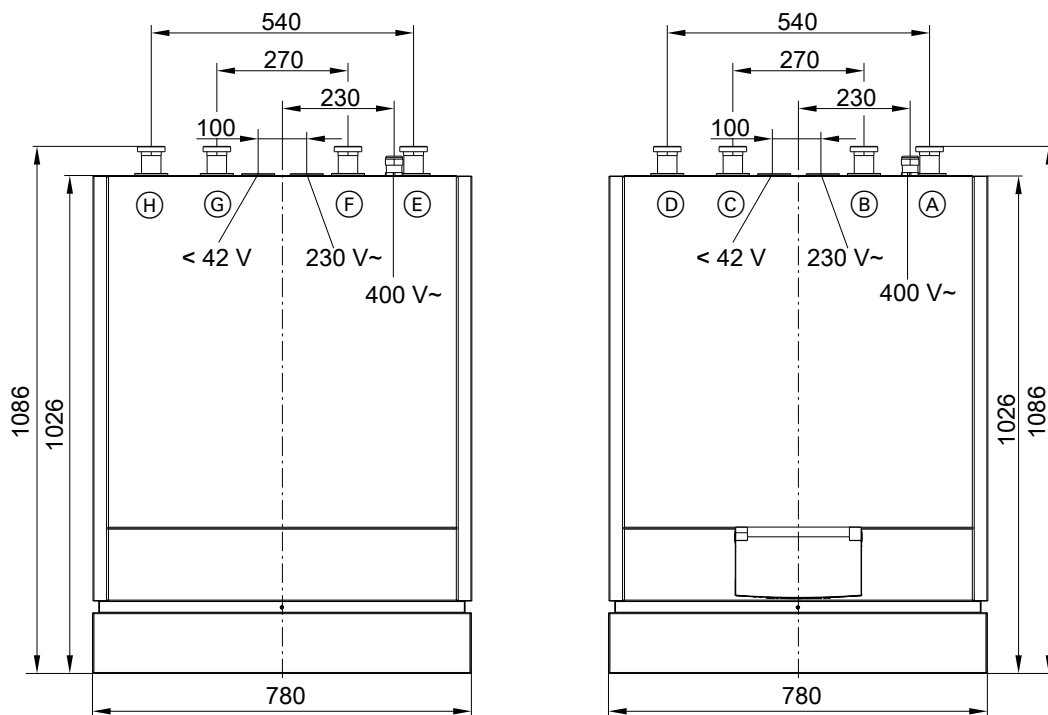

Type BWS on the left; type BW on the right

(A)/(E)	▲	Secondary circuit return
(B)/(F)	▼	Secondary circuit flow

(C)/(G)	▲	Primary circuit flow (heat pump brine inlet)
(D)/(H)	▼	Primary circuit return (heat pump brine outlet)

Application limits to EN 14511

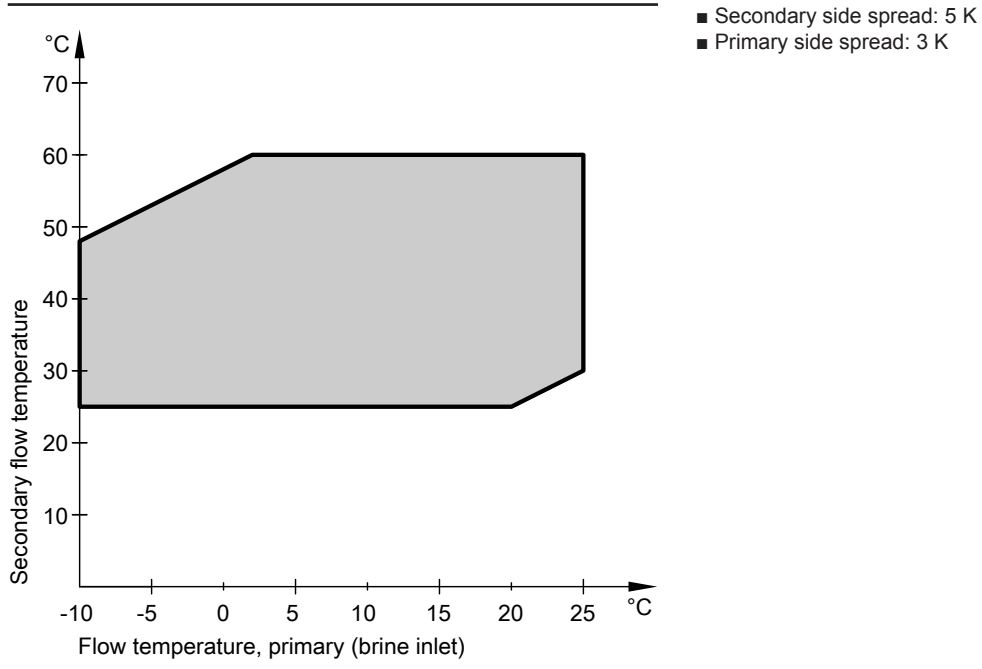

Curves, type BW, BWS

Type BW 301.A21, BWS 301.A21

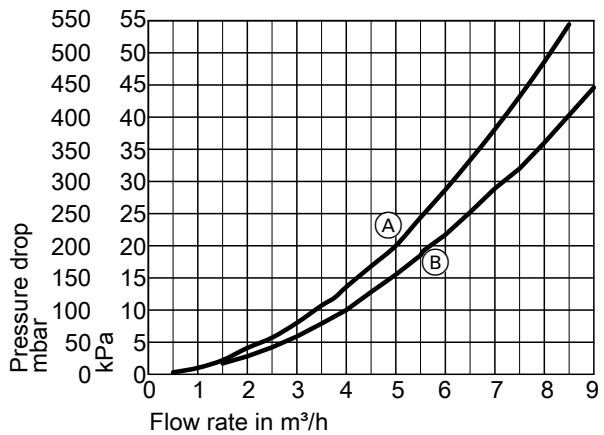
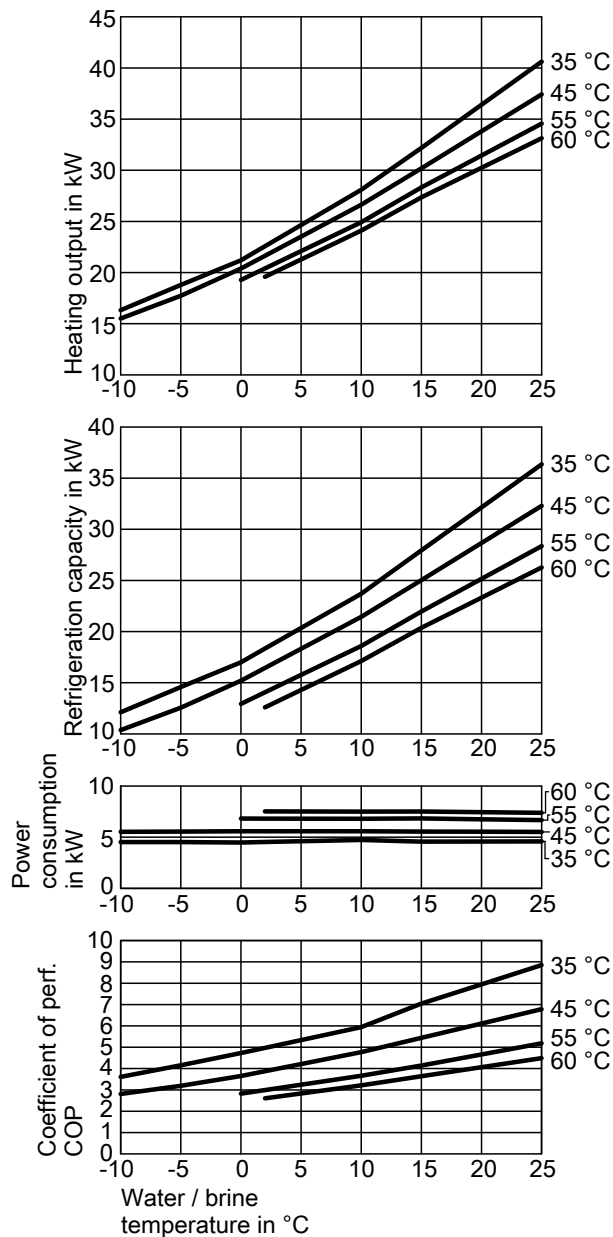

- (A) Secondary circuit
- (B) Primary circuit

Output data

Operating point	W B	°C °C	35				
			-5	0	2	10	15
Heating output	kW		18.79	21.20	22.58	28.10	32.19
Cooling capacity	kW		14.58	17.00	18.34	23.70	27.95
Power consumption	kW		4.52	4.48	4.53	4.73	4.57
Coefficient of performance ε (COP)			4.15	4.73	4.97	5.94	7.05

Operating point	W B	°C °C	45				
			-5	0	2	10	15
Heating output	kW		17.73	20.39	21.64	26.64	30.19
Cooling capacity	kW		12.57	15.20	16.45	21.44	25.03
Power consumption	kW		5.55	5.58	5.58	5.58	5.55
Coefficient of performance ε (COP)			3.19	3.65	3.88	4.77	5.44

Operating point	W B	°C °C	55			
			0	2	10	15
Heating output	kW		19.28	20.41	24.92	28.32
Cooling capacity	kW		12.94	14.07	18.59	21.97
Power consumption	kW		6.82	6.82	6.80	6.83
Coefficient of performance ε (COP)			2.83	2.99	3.66	4.15

Operating point	W B	°C °C	60		
			2	10	15
Heating output	kW		19.59	24.10	27.36
Cooling capacity	kW		12.59	17.13	20.37
Power consumption	kW		7.52	7.50	7.52
Coefficient of performance ε (COP)			2.61	3.21	3.64

Note

COP calculated with reference to EN 14511.

Performance characteristics are determined under the following conditions:

- New appliances with clean plate heat exchangers
- With high efficiency circulation pumps
- Primary circuit with Tyfocor heat transfer medium, 30 % by vol.
- Secondary circuit with water

4

Vitocal 300-G, type BW 301.A21 to A45, BWS 301.A21 to A45 (cont.)

Type BW 301.A29, BWS 301.A29

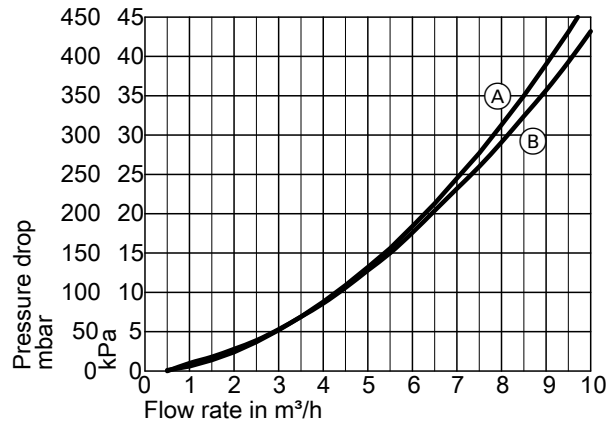
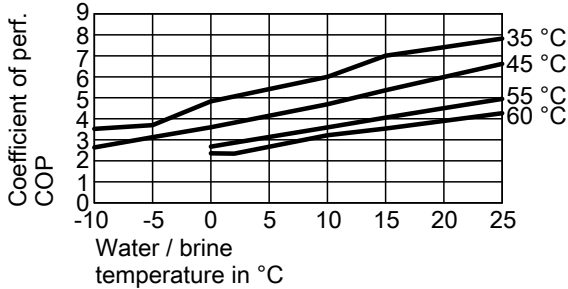
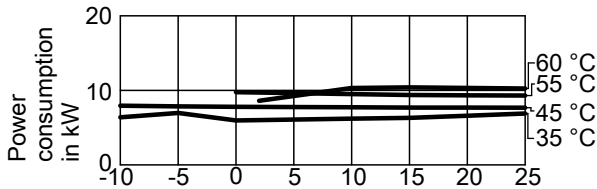
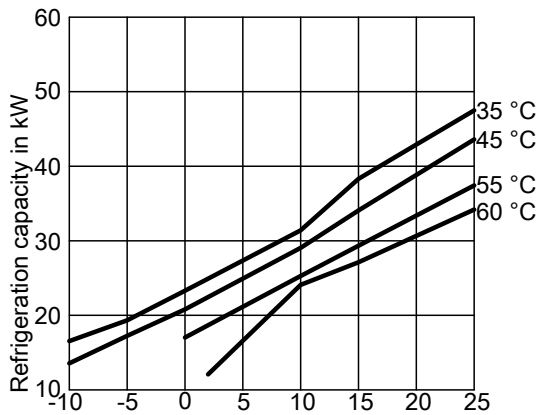
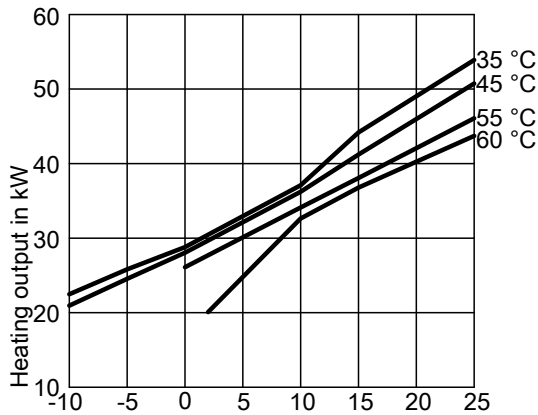

- (A) Secondary circuit
- (B) Primary circuit

Output data

Operating point	W B	°C °C	35				
			-5	0	2	10	15
Heating output		kW	25.03	28.80	30.46	37.10	44.18
Cooling capacity		kW	19.33	23.30	24.92	31.40	38.31
Power consumption		kW	6.97	5.96	6.01	6.20	6.31
Coefficient of performance ϵ (COP)			3.70	4.83	5.06	6.00	7.01

Operating point	W B	°C °C	45				
			-5	0	2	10	15
Heating output		kW	24.54	28.04	29.68	36.23	41.21
Cooling capacity		kW	17.24	20.80	22.45	29.05	34.07
Power consumption		kW	7.85	7.79	7.78	7.73	7.69
Coefficient of performance ϵ (COP)			3.13	3.60	3.82	4.69	5.36

Operating point	W B	°C °C	55			
			0	2	10	15
Heating output		kW	26.09	27.70	34.11	38.06
Cooling capacity		kW	17.02	18.67	25.27	29.34
Power consumption		kW	9.75	9.70	9.50	9.38
Coefficient of performance ϵ (COP)			2.68	2.86	3.59	4.06

Operating point	W B	°C °C	60		
			2	10	15
Heating output		kW	20.07	32.81	36.78
Cooling capacity		kW	12.08	24.50	27.12
Power consumption		kW	8.60	10.30	10.39
Coefficient of performance ϵ (COP)			2.34	3.11	3.54

Note

COP calculated with reference to EN 14511.

Performance characteristics are determined under the following conditions:

- New appliances with clean plate heat exchangers
- With high efficiency circulation pumps
- Primary circuit with Tyfocor heat transfer medium, 30 % by vol.
- Secondary circuit with water

Vitocal 300-G, type BW 301.A21 to A45, BWS 301.A21 to A45 (cont.)

Type BW 301.A45, BWS 301.A45

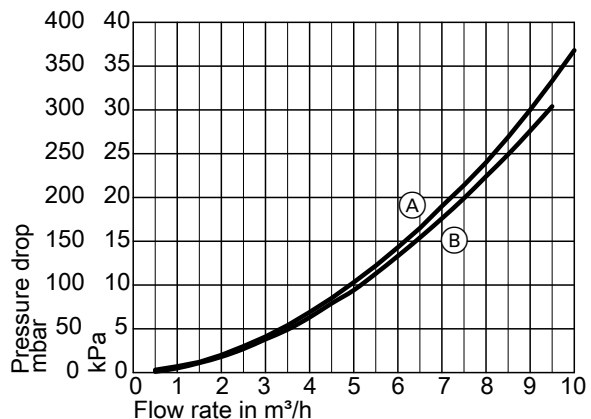
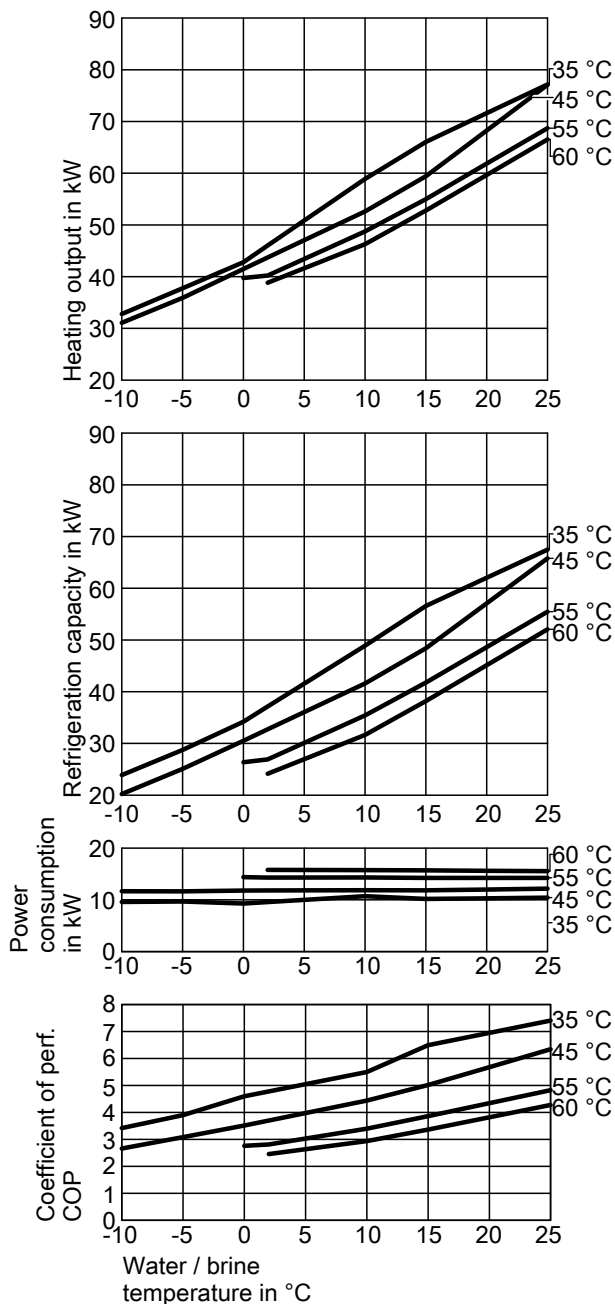

- (A) Secondary circuit
- (B) Primary circuit

Output data

Operating point	W B	°C °C	35				
			-5	0	2	10	15
Heating output		kW	37.75	42.80	46.02	58.90	66.05
Cooling capacity		kW	28.75	34.20	37.14	48.90	56.59
Power consumption		kW	9.67	9.28	9.56	10.70	10.17
Coefficient of performance ε (COP)			3.90	4.60	4.78	5.50	6.49

Operating point	W B	°C °C	45				
			-5	0	2	10	15
Heating output		kW	35.90	41.49	43.72	52.62	59.42
Cooling capacity		kW	25.08	30.52	32.74	41.60	48.40
Power consumption		kW	11.64	11.80	11.81	11.85	11.85
Coefficient of performance ε (COP)			3.09	3.52	3.70	4.44	5.02

Operating point	W B	°C °C	55			
			0	2	10	15
Heating output		kW	39.75	40.23	48.74	55.00
Cooling capacity		kW	26.38	26.92	35.41	41.76
Power consumption		kW	14.38	14.31	14.33	14.23
Coefficient of performance ε (COP)			2.76	2.81	3.40	3.86

Operating point	W B	°C °C	60		
			2	10	15
Heating output		kW	38.82	46.28	52.79
Cooling capacity		kW	24.14	31.64	38.19
Power consumption		kW	15.79	15.75	15.69
Coefficient of performance ε (COP)			2.46	2.94	3.36

Note
COP calculated with reference to EN 14511.

Performance characteristics are determined under the following conditions:

- New appliances with clean plate heat exchangers
- With high efficiency circulation pumps
- Primary circuit with Tyfocor heat transfer medium, 30 % by vol.
- Secondary circuit with water

5.1 Product description

Benefits of type BW, BWS

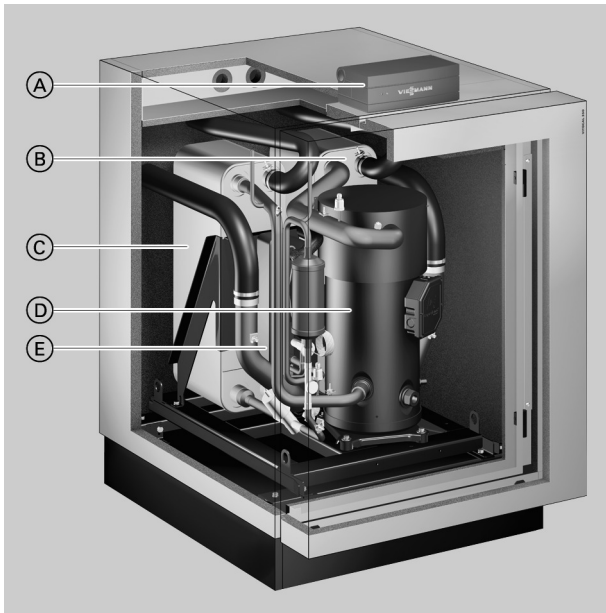

- Ⓐ Vitotronic 200 weather-compensated, digital heat pump control unit
- Ⓑ Condenser
- Ⓒ Evaporator
- Ⓓ Hermetically sealed Compliant scroll compressor with enhanced vapour injection — EVI process
- Ⓔ Heat exchanger for enhanced vapour injection

- Low running costs thanks to a high COP to EN 14511: Up to 5.0 (B0/W35)
- Mono mode operation for central heating and DHW heating
- Flow temperatures up to 68 °C
- Achievable DHW temperature up to 60 °C when using the specified loading cylinder system
- Low noise and vibration levels through sound-optimised appliance design – sound power level < 52 dB(A)
- Low running costs with the highest level of efficiency at any operating point through the innovative Refrigerant Cycle Diagnostic system (RCD) with electronic expansion valve (EEV)
- With the 2-stage version (type BW+BWS):
Highly flexible due to option of combining modules of different outputs
Easier handling through smaller and lighter modules

Only type BW:

- Easy-to-use Vitotronic control unit with plain text and graphic display for weather-compensated heating mode and natural or active cooling
- Optimised utilisation of power generated by an on-site photovoltaic system
- Web-enabled through Vitoconnect (accessories) for operation and service via Viessmann apps

Delivered condition, type BW

- Complete compact heat pump as a single stage heat pump or as stage 1 (master) of a 2-stage heat pump
- Adjustable anti-vibration feet
- Weather-compensated Vitotronic 200 heat pump control unit with outside temperature sensor
- Electronic starting current limiter and integral phase monitor

Delivered condition, type BWS

- Compact heat pump as stage 2 (slave)
- Adjustable anti-vibration feet
- Electrical connecting cable for connection to stage 1 (master).
- Electronic starting current limiter

5.2 Specification

Specification for brine/water heat pumps

Type BW/BWS		351.B20	351.B27	351.B33	351.B42
Performance data to EN 14511 (B0/W35, 5 K spread)					
Rated heating output	kW	20.5	28.7	32.7	42.3
Cooling capacity	kW	16.4	23.0	26.3	33.6
Power consumption	kW	4.30	5.90	6.50	8.70
Coefficient of performance (COP)		4.80	4.90	5.00	4.80
Brine (primary circuit)					
Capacity	l	9	11	14	14
Nominal flow rate (3 K spread)	l/h	5350	7200	8300	10500
Pressure drop at nominal flow rate	mbar	100	50	84	124
	kPa	10.0	5.0	8.4	12.4
Minimum flow rate (4 K spread)	l/h	4000	5400	6200	7900
Pressure drop at minimum flow rate	mbar	63	30	52	78
	kPa	6.3	3.0	5.2	7.8
Max. flow temperature (brine inlet)	°C	25	25	25	25
Min. flow temperature (brine inlet)	°C	-10	-10	-10	-10
Heating water (secondary circuit)					
Capacity	l	8	9	13	13
Nominal flow rate (5 K spread)	l/h	3500	4800	5650	7000
Pressure drop at nominal flow rate	mbar	42	40	65	99
	kPa	4.2	4.0	6.5	9.9
Minimum flow rate (12 K spread)	l/h	1500	2050	2400	3000
Pressure drop at minimum flow rate	mbar	7	10	16	23
	kPa	0.7	1.0	1.6	2.3
Max. flow temperature (6 K spread)	°C	65	68	68	68
Electrical values, heat pump					
Rated voltage, compressor	V	3/PE 400 V/50 Hz			
Rated current, compressor	A	13.2	21	26	33
Cos φ		0.8	0.8	0.8	0.8
Starting current, compressor (with starting current limiter)	A	36	39	43	59
Starting current, compressor with stalled armature	A	101	118	140	174
Compressor MCB/fuse protection	A	1 x C25A	1 x C32A	1 x C32A	1 x C40A
Protection class		3-pole I	3-pole I	3-pole I	3-pole I
Electrical values, heat pump control unit					
Rated voltage, heat pump control unit/PCB	V	1/N/PE 230 V/50 Hz			
Fuse rating, heat pump control unit/PCB		1 x B16A			
Fuse, heat pump control unit/PCB	A	6.3 A (slow)/250 V			
IP rating		IP 20	IP 20	IP 20	IP 20
Power consumption					
Max. power consumption, heat pump control unit/PCB, heat pump stage 1 (type BW 351.B)	W	25	25	25	25
Max. power consumption, PCB, heat pump stage 2 (type BWS 351.B)		20	20	20	20
Power consumption, heat pump control unit/PCB, stages 1 and 2	W	45	45	45	45
Refrigerant circuit					
Refrigerant		R410A	R410A	R410A	R410A
– Refrigerant charge	kg	5.3	7.0	8.6	8.7
– Global warming potential (GWP) ^{*5}		1924	1924	1924	1924
– CO ₂ equivalent	t	10.2	13.5	16.5	16.7
Permiss. operating pressure, high pressure side	bar	45	45	45	45
	MPa	4.5	4.5	4.5	4.5
Permiss. operating pressure, low pressure side	bar	28	28	28	28
	MPa	2.8	2.8	2.8	2.8
Compressor	Type	Hermetically sealed scroll compressor			
Oil in compressor	Type	Emkarate RL32 3MAF			
Quantity of oil in compressor	l	1.9	3.4	3.4	3.4
Permiss. operating pressure					
Primary circuit	bar	3	3	3	3
	MPa	0.3	0.3	0.3	0.3
Secondary circuit	bar	3	3	3	3
	MPa	0.3	0.3	0.3	0.3

*5 Based on the Fifth Assessment Report of the Intergovernmental Panel on Climate Change (IPCC).

Vitocal 350-G, type BW 351.B20 to B42, BWS 351.B20 to B42 (cont.)

Type BW/BWS		351.B20	351.B27	351.B33	351.B42
Dimensions					
Total length	mm	1085	1085	1085	1085
Total width	mm	780	780	780	780
Total height without programming unit	mm	1074	1074	1074	1074
Total height (programming unit pivoted up, type BW 351.B only)	mm	1267	1267	1267	1267
Weight					
Heat pump stage 1 (type BW 351.B)	kg	270	285	310	315
Heat pump stage 2 (type BWS 351.B)	kg	265	280	305	310
Connections (male thread)					
Primary circuit flow/return	G	2	2	2	2
Secondary circuit flow/return	G	2	2	2	2
Sound power (measured with reference to EN 12102/ EN ISO 9614-2)					
Weighted total sound power level for B0 ^{±3} K/W35 ^{±5} K					
– At rated heating output	dB(A)	50	52	50	50
Energy efficiency class to EU Regulation no. 813/2013					
Heating, average climatic conditions					
– Low temperature applications (W35)		A ⁺⁺	A ⁺⁺	A ⁺⁺	A ⁺⁺
– Medium temperature applications (W55)		A ⁺⁺	A ⁺⁺	A ⁺⁺	A ⁺⁺
Performance data as per EU Regulation no. 813/2013 (average climatic conditions)					
Low temperature applications (W35)					
– Energy efficiency η_s	%	196	203	213	203
– Rated heating output P_{rated}	kW	23	32	37	48
– Seasonal coefficient of performance (SCOP)		5.10	5.28	5.53	5.28
Medium temperature applications (W55)					
– Energy efficiency η_s	%	152	153	156	153
– Rated heating output P_{rated}	kW	23	34	38	49
– Seasonal coefficient of performance (SCOP)		4.00	4.03	4.10	4.03

Specification for water/water heat pumps

Type BW/BWS in conjunction with "conversion kit for water/water heat pump"		351.B20	351.B27	351.B33	351.B42
Performance data to EN 14511 (W10/W35, 5 K spread)					
Rated heating output	kW	25.4	34.7	42.2	52.3
Cooling capacity	kW	21.1	29.3	35.7	43.8
Power consumption	kW	4.50	5.70	6.80	9.00
Coefficient of performance (COP)		5.70	6.10	6.20	5.80
Brine (primary intermediate circuit)					
Capacity	l	9	11	14	14
Nominal flow rate (3 K spread)	l/h	6400	9500	10300	14000
Pressure drop at nominal flow rate	mbar	145	80	120	320
	kPa	14.5	8.0	12.0	32.0
Minimum flow rate (5 K spread)	l/h	4800	6500	7700	10500
Pressure drop at minimum flow rate	mbar	90	42	77	124
	kPa	9.0	4.2	7.7	12.4
Max. flow temperature (brine inlet)	°C	25	25	25	25
Min. flow temperature (brine inlet)	°C	7.5	7.5	7.5	7.5
Heating water (secondary circuit)					
Capacity	l	8	9	13	13
Nominal flow rate (5 K spread)	l/h	4300	5700	7300	9000
Pressure drop at nominal flow rate	mbar	68	53	105	154
	kPa	6.8	5.3	10.5	15.4
Minimum flow rate (12 K spread)	l/h	1800	2400	3050	3750
Pressure drop at minimum flow rate	mbar	11	13	23.0	33
	kPa	1.1	1.3	2.3	3.3
Max. flow temperature (6 K spread)	°C	68	68	68	68

Note

Further specifications: See "Specification for brine/water heat pumps"

Vitocal 350-G, type BW 351.B20 to B42, BWS 351.B20 to B42 (cont.)

Dimensions, type BW 351.B20 to B42, BWS 351.B20 to B42

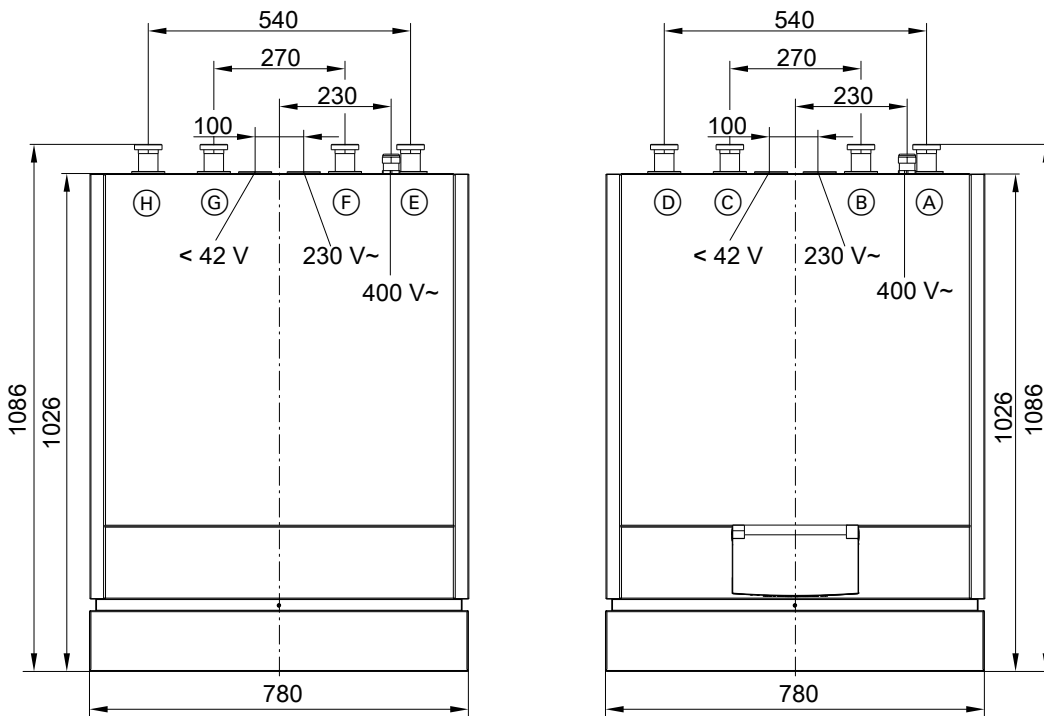
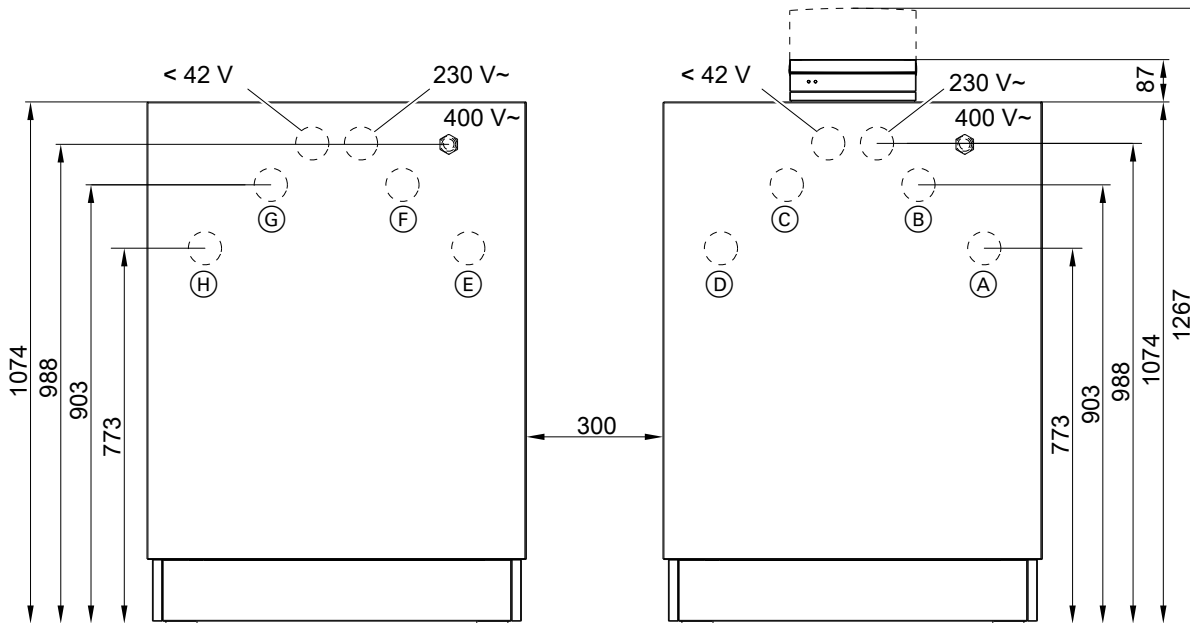

Type BWS on the left; type BW on the right

(A)/(E)	▲ ■+□	Secondary circuit return
(B)/(F)	▼ ■+□	Secondary circuit flow
(C)/(G)	▲ □	Primary circuit flow (heat pump brine inlet)
(D)/(H)	▼ □	Primary circuit return (heat pump brine outlet)

Application limits

Type BW/BWS 351.B20
Flow temperature 65 °C

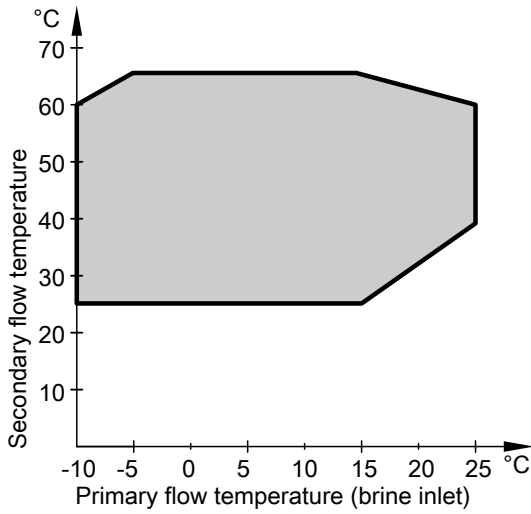

- Secondary side spread: 6 K
- Primary side spread: 3 K

Type BW/BWS 351.B27, 351.B33, 351.B42
Flow temperature 68 °C

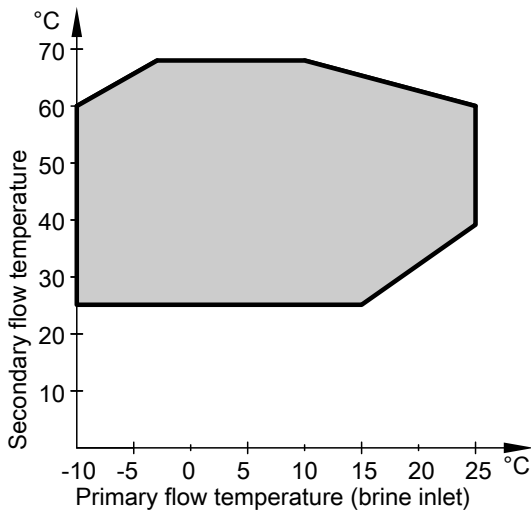

- Secondary side spread: 6 K
- Primary side spread: 3 K

DHW temperature of 60 °C in conjunction with Vitocell 100-L, type CVL and cylinder loading system

Only for type BW/BWS 351.B27, 351.B33, 351.B42.

- To achieve a DHW temperature of 60 °C, the temperature spread in the secondary circuit must be regulated to 6 K. This is done by adjusting the pump rates of all circulation pumps for DHW heating, e.g. secondary pump, cylinder loading pump, etc.
- Please observe the sizing information for the cylinder loading system (see page 165).
- If temperatures above +12 °C are expected from the primary source, a low end controller must be factored in for the primary circuit flow temperature (heat pump brine inlet). Otherwise the max. flow temperature of 68 °C cannot be provided via the heat pump and a DHW temperature of 60 °C cannot be achieved.

DHW temperature in conjunction with heating water buffer cylinder and freshwater module

A heat pump operating in mono mode **cannot** ensure an outlet temperature of 60 °C at the freshwater module. If this is required, the heat pump must be operated in dual mode (e.g. with a peak load boiler).

Curves, type BW 351.B20 to B42, BWS 351.B20 to B42

Type BW 351.B20, BWS 351.B20

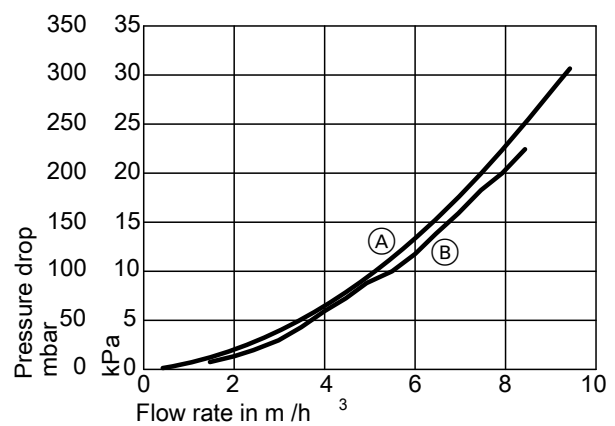
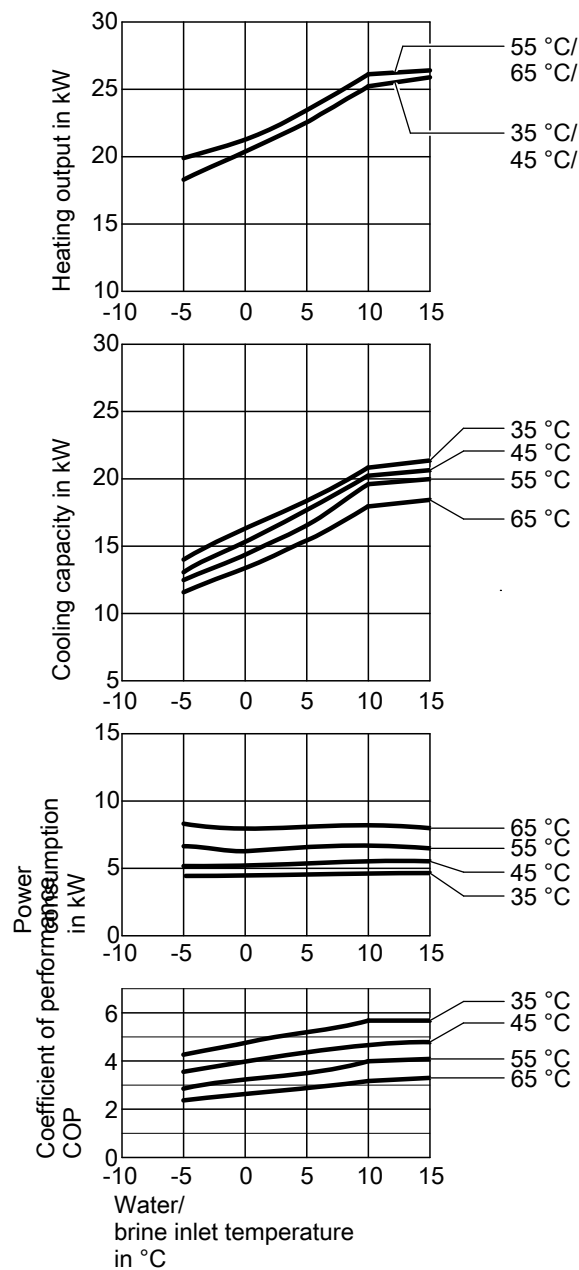

- (A) Secondary circuit
- (B) Primary circuit

Performance data

Operating point	W B	°C °C	35				
			-5	0	5	10	15
Heating output		kW	18.4	20.5	22.7	25.4	26.0
Cooling capacity		kW	14.1	16.2	18.3	20.9	21.4
Power consumption		kW	4.30	4.30	4.40	4.50	4.60
Coefficient of performance (COP)			4.30	4.80	5.20	5.70	5.70

Operating point	W B	°C °C	45				
			-5	0	5	10	15
Heating output		kW	18.3	20.6	22.9	25.8	26.2
Cooling capacity		kW	13.2	15.4	17.7	20.3	20.7
Power consumption		kW	5.10	5.20	5.20	5.50	5.50
Coefficient of performance (COP)			3.60	4.00	4.40	4.70	4.80

Operating point	W B	°C °C	55				
			-5	0	5	10	15
Heating output		kW	19.1	20.6	23.1	26.2	26.6
Cooling capacity		kW	12.5	14.4	16.5	19.6	20.1
Power consumption		kW	6.60	6.20	6.60	6.60	6.50
Coefficient of performance (COP)			2.90	3.30	3.50	4.00	4.10

Operating point	W B	°C °C	65				
			-5	0	5	10	15
Heating output		kW	20.0	21.3	23.5	26.2	26.5
Cooling capacity		kW	11.7	13.4	15.4	18.0	18.5
Power consumption		kW	8.30	7.90	8.10	8.20	8.00
Coefficient of performance (COP)			2.40	2.70	2.90	3.20	3.30

Note
COP calculated with reference to EN 14511.

Performance characteristics are determined under the following conditions:

- New appliances with clean plate heat exchangers
- With high efficiency circulation pumps
- Primary circuit with Tyfocor heat transfer medium, 30 % by vol.
- Secondary circuit with water

Vitocal 350-G, type BW 351.B20 to B42, BWS 351.B20 to B42 (cont.)

Type BW 351.B27, BWS 351.B27

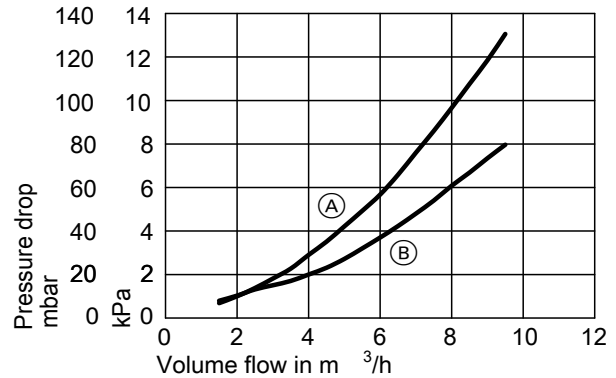
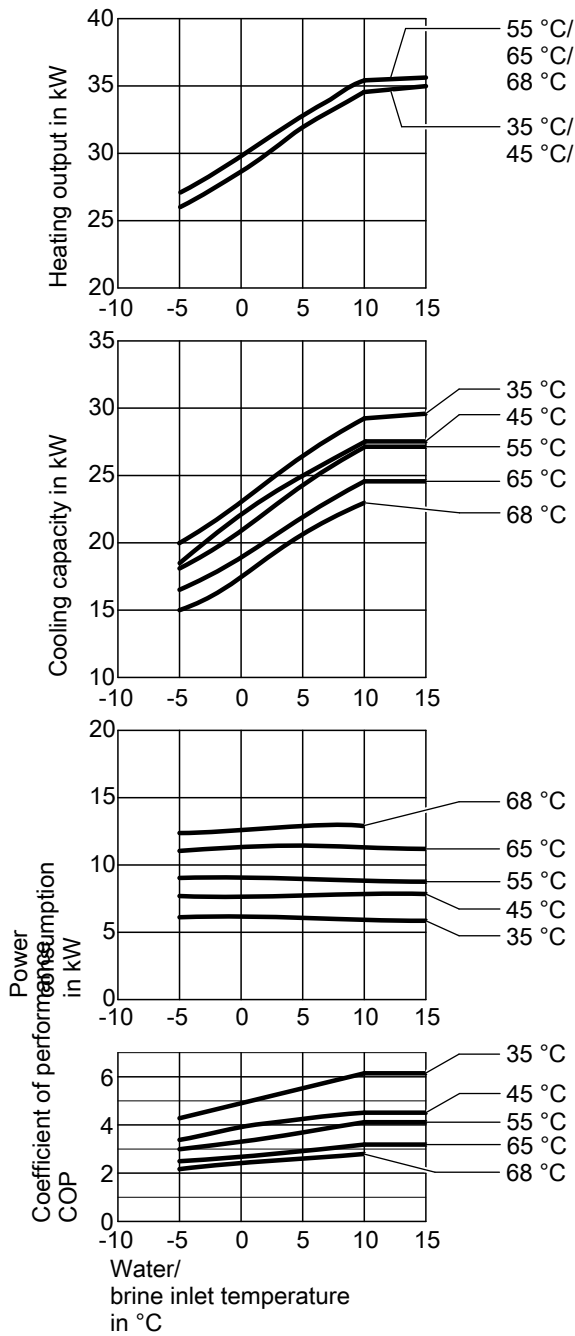

- (A) Secondary circuit
- (B) Primary circuit

Performance data

Operating point	W B	°C °C	35				
			-5	0	5	10	15
Heating output		kW	26.0	28.7	32.1	34.7	35.2
Cooling capacity		kW	20.0	22.8	26.3	29.0	29.4
Power consumption		kW	6.00	5.90	5.80	5.70	5.80
Coefficient of performance (COP)			4.30	4.90	5.50	6.10	6.10

Operating point	W B	°C °C	45				
			-5	0	5	10	15
Heating output		kW	26.2	29.6	32.5	35.1	35.3
Cooling capacity		kW	18.5	22.0	24.9	27.3	27.5
Power consumption		kW	7.70	7.60	7.60	7.80	7.80
Coefficient of performance (COP)			3.40	3.90	4.30	4.50	4.50

Operating point	W B	°C °C	55				
			-5	0	5	10	15
Heating output		kW	27.1	29.9	33.0	35.7	35.8
Cooling capacity		kW	18.1	20.8	24.1	27.0	27.1
Power consumption		kW	9.00	9.10	8.90	8.70	8.70
Coefficient of performance (COP)			3.00	3.30	3.70	4.10	4.10

Operating point	W B	°C °C	65				
			-5	0	5	10	15
Heating output		kW	27.5	30.0	33.3	35.6	35.7
Cooling capacity		kW	16.5	18.9	21.8	24.5	24.5
Power consumption		kW	11.00	11.10	11.50	11.10	11.20
Coefficient of performance (COP)			2.50	2.70	2.90	3.20	3.20

Operating point	W B	°C °C	68			
			-5	0	5	10
Heating output		kW	27.3	29.7	33.5	35.8
Cooling capacity		kW	14.9	17.3	20.6	23.0
Power consumption		kW	12.40	12.40	12.90	12.80
Coefficient of performance (COP)			2.20	2.40	2.60	2.80

Note

COP calculated with reference to EN 14511.

Performance characteristics are determined under the following conditions:

- New appliances with clean plate heat exchangers
- With high efficiency circulation pumps
- Primary circuit with Tyfocor heat transfer medium, 30 % by vol.
- Secondary circuit with water

Vitocal 350-G, type BW 351.B20 to B42, BWS 351.B20 to B42 (cont.)

Type BW 351.B33, BWS 351.B33

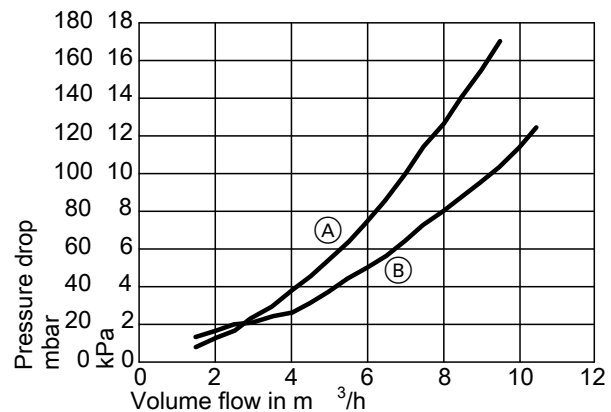
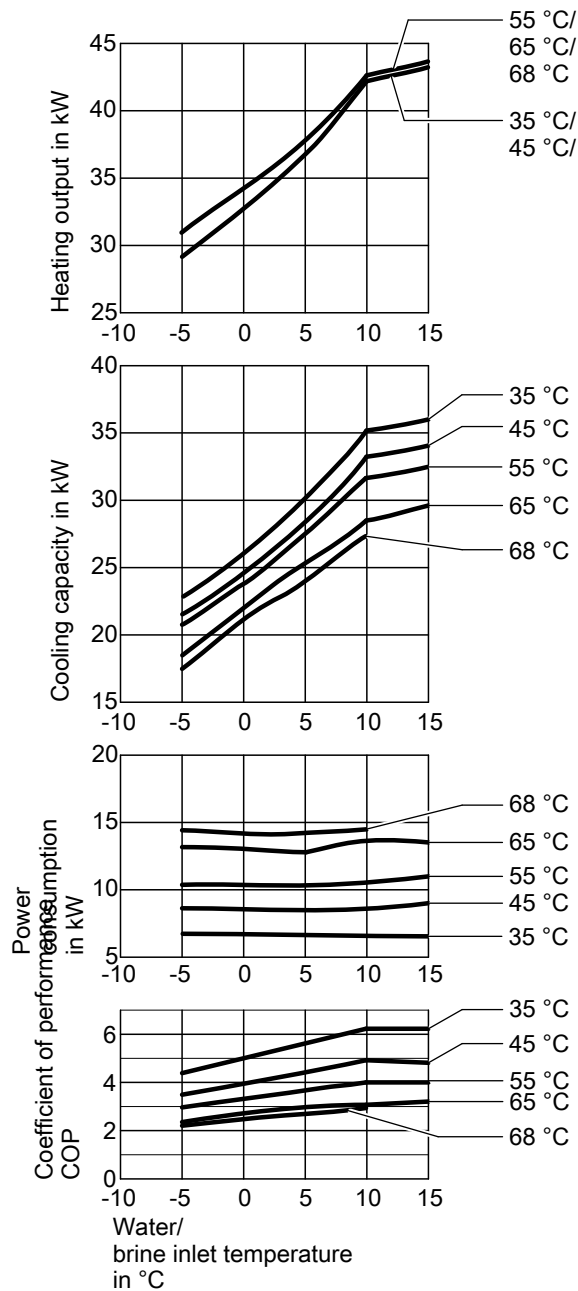

- (A) Secondary circuit
- (B) Primary circuit

Performance data

Operating point	W B	°C °C	35				
			-5	0	5	10	15
Heating output		kW	29.2	32.7	36.6	42.2	43.3
Cooling capacity		kW	22.6	26.2	30.1	35.4	36.3
Power consumption		kW	6.60	6.50	6.50	6.80	7.00
Coefficient of performance (COP)			4.40	5.00	5.60	6.20	6.20

Operating point	W B	°C °C	45				
			-5	0	5	10	15
Heating output		kW	30.0	33.3	36.7	42.0	43.3
Cooling capacity		kW	21.4	24.8	28.4	33.4	34.3
Power consumption		kW	8.60	8.50	8.30	8.60	9.00
Coefficient of performance (COP)			3.50	3.90	4.40	4.90	4.80

Operating point	W B	°C °C	55				
			-5	0	5	10	15
Heating output		kW	31.0	34.2	37.7	42.5	43.6
Cooling capacity		kW	20.7	23.8	27.5	31.9	32.7
Power consumption		kW	10.30	10.40	10.20	10.60	10.90
Coefficient of performance (COP)			3.00	3.30	3.70	4.00	4.00

Operating point	W B	°C °C	65				
			-5	0	5	10	15
Heating output		kW	31.5	35.0	38.2	42.3	43.2
Cooling capacity		kW	18.4	22.0	25.5	28.7	29.7
Power consumption		kW	13.10	13.00	12.70	13.60	13.50
Coefficient of performance (COP)			2.40	2.70	3.00	3.10	3.20

Operating point	W B	°C °C	68			
			-5	0	5	10
Heating output		kW	31.7	35.1	38.1	42.0
Cooling capacity		kW	17.3	21.1	24.0	27.5
Power consumption		kW	14.40	14.00	14.10	14.50
Coefficient of performance (COP)			2.20	2.50	2.70	2.90

Note
COP calculated with reference to EN 14511.

Performance characteristics are determined under the following conditions:

- New appliances with clean plate heat exchangers
- With high efficiency circulation pumps
- Primary circuit with Tyfocor heat transfer medium, 30 % by vol.
- Secondary circuit with water

Vitocal 350-G, type BW 351.B20 to B42, BWS 351.B20 to B42 (cont.)

Type BW 351.B42, BWS 351.B42

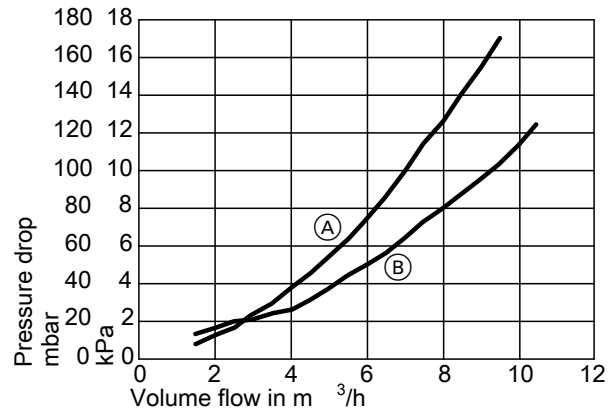
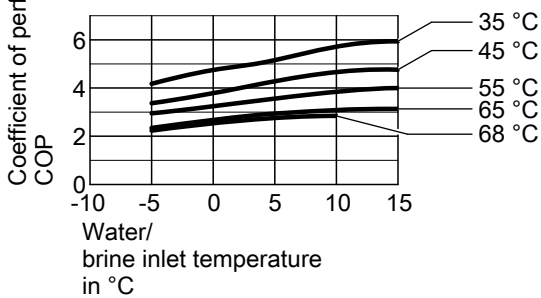
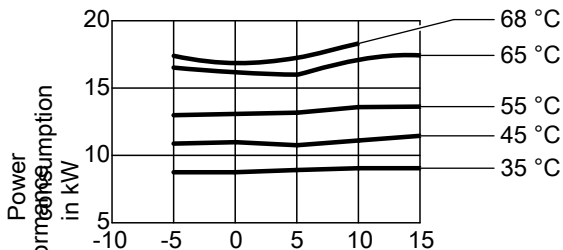
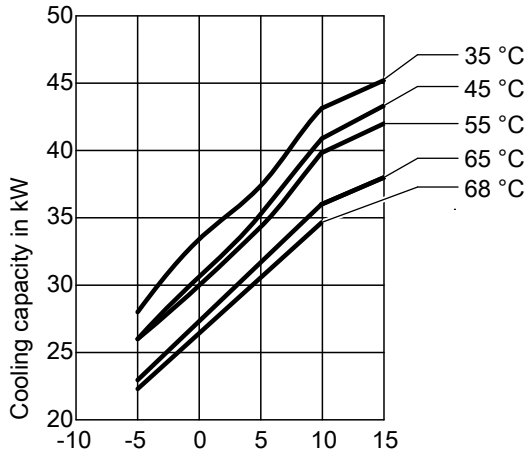
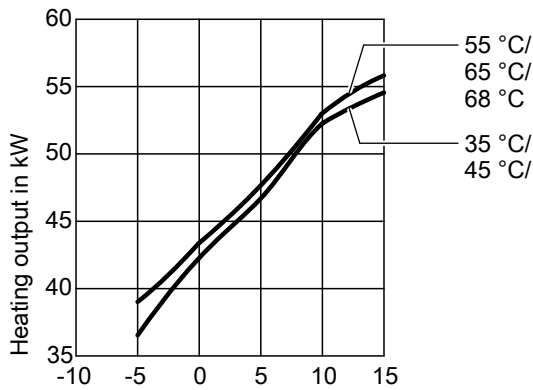

- (A) Secondary circuit
- (B) Primary circuit

Performance data

Operating point	W B	°C °C	35				
			-5	0	5	10	15
Heating output		kW	36.7	42.3	46.4	52.3	54.4
Cooling capacity		kW	28.0	33.6	37.5	43.3	45.3
Power consumption		kW	8.70	8.70	8.90	9.00	9.10
Coefficient of performance (COP)			4.20	4.80	5.20	5.80	6.00

Operating point	W B	°C °C	45				
			-5	0	5	10	15
Heating output		kW	37.0	41.5	46.1	52.1	54.8
Cooling capacity		kW	26.1	30.6	35.4	41.0	43.4
Power consumption		kW	10.90	10.90	10.70	11.10	11.40
Coefficient of performance (COP)			3.40	3.80	4.30	4.70	4.80

Operating point	W B	°C °C	55				
			-5	0	5	10	15
Heating output		kW	39.0	43.1	47.4	52.9	55.7
Cooling capacity		kW	26.0	30.0	34.2	39.9	42.1
Power consumption		kW	13.00	13.10	13.20	13.60	13.60
Coefficient of performance (COP)			3.00	3.30	3.60	3.90	4.10

Operating point	W B	°C °C	65				
			-5	0	5	10	15
Heating output		kW	39.5	43.6	47.8	53.2	55.9
Cooling capacity		kW	23.0	27.4	31.5	36.0	38.0
Power consumption		kW	16.50	16.20	15.90	17.20	17.50
Coefficient of performance (COP)			2.40	2.70	3.00	3.10	3.20

Operating point	W B	°C °C	68			
			-5	0	5	10
Heating output		kW	39.7	43.4	48.1	53.0
Cooling capacity		kW	22.4	26.6	30.9	34.7
Power consumption		kW	17.30	16.80	17.20	18.30
Coefficient of performance (COP)			2.30	2.60	2.80	2.90

Note

COP calculated with reference to EN 14511.

Performance characteristics are determined under the following conditions:

- New appliances with clean plate heat exchangers
- With high efficiency circulation pumps
- Primary circuit with Tyfocor heat transfer medium, 30 % by vol.
- Secondary circuit with water

6.1 Product description

Benefits

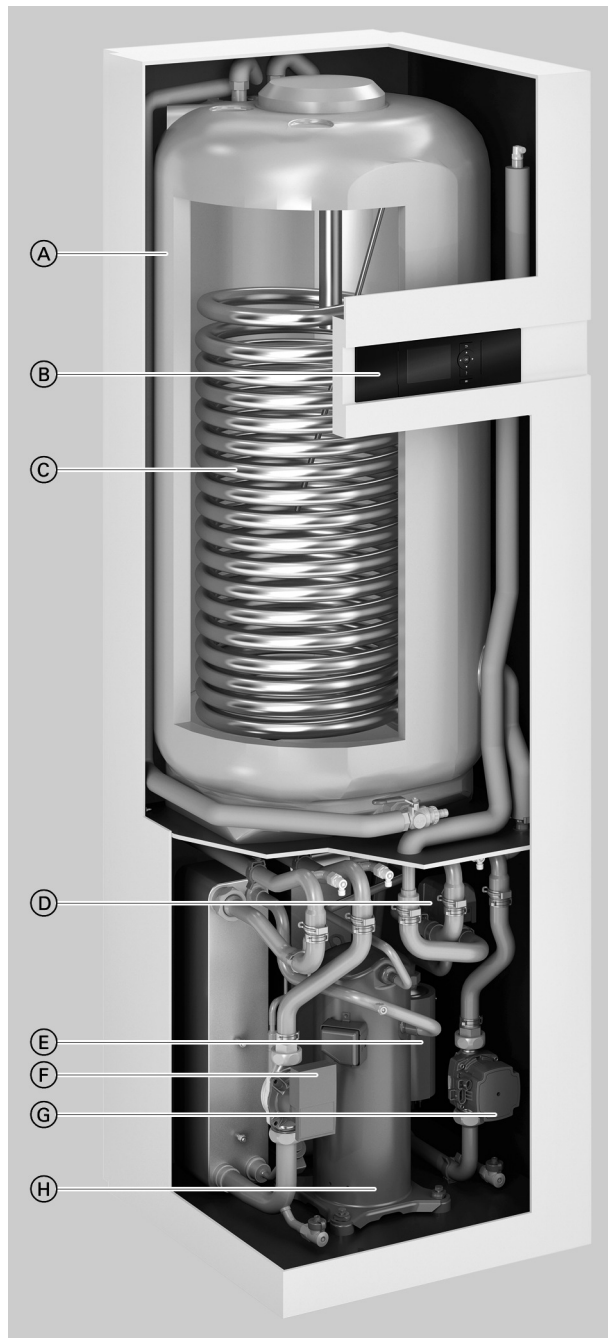

- Ⓐ DHW cylinder with 220 l capacity
- Ⓑ Vitotronic 200 weather-compensated, digital heat pump control unit
- Ⓒ Indirect coil for cylinder heating
- Ⓓ 3-way diverter valve for central heating/DHW heating
- Ⓔ Instantaneous heating water heater
- Ⓕ Primary pump (brine), high efficiency circulation pump
- Ⓖ Secondary pump (heating water), high efficiency circulation pump
- Ⓗ Hermetically sealed Compliant scroll compressor

6

- Low running costs thanks to a high COP to EN 14511: Up to 4.8 (B0/W35)
- Maximum flow temperatures of up to 65 °C for high DHW convenience
- Especially quiet thanks to new sound insulation concept: 46 dB(A) (B0/W55)
- Low running costs with high level of efficiency at any operating point through the innovative RCD (refrigerant cycle diagnostic) system with electronic expansion valve (EEV)
- High DHW convenience (A+ energy label) and very high draw-off rates (293 l)

- Easy to operate Vitotronic control unit with plain text and graphic display
- Easy handling as the heat pump module can be quickly removed thanks to push-fit connections
- Optimised utilisation of power generated on-site by a photovoltaic system
- Control of compatible Vitovent ventilation units
- Web-enabled through Vitoconnect (accessories) for operation and service via Viessmann apps

Delivered condition

- Brine/water heat pump for central heating and DHW heating
- Integral steel DHW cylinder with Ceraprotect enamel coating, protected from corrosion by a protective magnesium anode, with thermal insulation
- Integral diverter valve for central heating/DHW heating
- Integral high efficiency circulation pump for primary circuit (brine)
- Integral high efficiency circulation pump for secondary circuit (heating water)
- Integral instantaneous heating water heater
- Safety assembly for the heating circuit (supplied)
- Vitotronic 200 weather-compensated heat pump control unit with outside temperature sensor
- Electronic starting current limiter
- Connection lines for primary circuit (brine) flow and return can be connected on the left or right (supplied)
- Connection lines for secondary circuit (heating water) flow and return for connection at the top (supplied)

6.2 Specification

Specification

Type BWT-M		221.B06	221.B08	221.B10
Performance data to EN 14511 (B0/W35, 5 K spread)				
Rated heating output	kW	5.71	7.47	10.29
Cooling capacity	kW	4.32	5.94	8.20
Power consumption	kW	1.36	1.78	2.32
Coefficient of performance ϵ (COP)		4.20	4.20	4.60
Brine (primary circuit)				
Capacity	l	3.3	3.3	3.9
Minimum flow rate	l/h	860	1160	1470
Residual head at minimum flow rate	mbar	610	620	580
	kPa	61.0	62.0	58.0
Residual head at nominal flow rate	mbar	586	620	580
	kPa	58.6	62.0	58.0
Max. flow temperature (brine inlet)	°C	25	25	25
Min. flow temperature (brine inlet)	°C	-10	-10	-10
Heating water (secondary circuit)				
Capacity, heat pump	l	3.3	3.5	3.8
Capacity, total	l	226	227	228
Minimum flow rate	l/h	600	710	920
Residual head at minimum flow rate	mbar	600	620	610
	kPa	60.0	62.0	61.0
Residual head at nominal flow rate	mbar	576	620	610
	kPa	57.6	62.0	61.0
Max. flow temperature	°C	65	65	65
Instantaneous heating water heater				
Heating output	kW	9.0		
Rated voltage		1/N/PE 230 V/50 Hz		
Fuse rating		3 x B16A 1-pole		
Heat pump electrical values				
Rated voltage, compressor		1/N/PE 230 V/50 Hz		
Rated current, compressor	A	12.8	17.1	22.8
Cos ϕ		0.9	0.9	0.9
Starting current, compressor with starting current limiter	A	23.9	25.6	38.7
Starting current, compressor with stalled armature	A	60	83	108
Compressor fuse rating	A	B16A	B20A	B25A
Rated voltage, heat pump control unit/PCB		1/N/PE 230 V/50 Hz		
MCB/fuse, heat pump control unit/PCB (internal)		6.3 A (slow) / 250 V		
Power consumption				
Primary pump (high efficiency circulation pump)	W	5 to 70		
– Energy efficiency index EEI		≤ 0.21		
Secondary pump (high efficiency circulation pump)	W	5.7 to 87		
– Energy efficiency index EEI		≤ 0.21		
Max. power consumption, control unit	W	1000	1000	1000
Rated output, control unit/PCB	W	12	12	12
Refrigerant circuit				
Refrigerant		R410A	R410A	R410A
– Refrigerant charge	kg	1.4	1.95	2.4
– Global warming potential (GWP) ^{*6}		1924	1924	1924
– CO ₂ equivalent	t	2.7	3.8	4.6
Permiss. operating pressure				
– High pressure side	bar	45	45	45
	MPa	4.5	4.5	4.5
– Low pressure side	bar	28	28	28
	MPa	2.8	2.8	2.8
Compressor	Type	Hermetically sealed scroll compressor		
Oil in compressor	Type	Emkarate RL32 3MAF		
Quantity of oil in compressor	l	0.74	1.24	1.24
Integral DHW cylinder				
Capacity	l	220	220	220
Max. draw-off volume at DHW temperature 40 °C, storage temperature 53 °C and draw-off rate 10 l/min	l	293	293	293
Max. DHW temperature				
– Only with heat pump	°C	58	58	58
– With instantaneous heating water heater	°C	63	63	63
Max. permiss. DHW temperature	°C	95	95	95

^{*6} Based on the Fifth Assessment Report of the Intergovernmental Panel on Climate Change (IPCC).

Vitocal 222-G, type BWT 221.B06 to B10 (cont.)

Type BWT-M		221.B06	221.B08	221.B10
Dimensions				
Total length	mm	680	680	680
Total width	mm	600	600	600
Total height	mm	2000	2000	2000
Weight				
Total weight	kg	277	282	288
Heat pump module	kg	74	77	81
Permiss. operating pressure				
Primary circuit (brine)	bar	3.0	3.0	3.0
	MPa	0.3	0.3	0.3
Secondary circuit, heating water	bar	3.0	3.0	3.0
	MPa	0.3	0.3	0.3
Secondary circuit, DHW	bar	10.0	10.0	10.0
	MPa	1.0	1.0	1.0
Connections				
Primary circuit flow/return	mm	Cu 28 x 1.5	Cu 28 x 1.5	Cu 28 x 1.5
Secondary circuit flow/return	mm	Cu 28 x 1.5	Cu 28 x 1.5	Cu 28 x 1.5
Cold water, DHW (female thread)	Rp	¾	¾	¾
DHW circulation (female thread)	Rp	¾	¾	¾
Sound power level (tested with reference to EN 12102/ EN ISO 9614-2) Weighted total sound power level at B0±3 K/ W35±5 K				
– At rated heating output	dB(A)	40	42	45
Energy efficiency class to EU Regulation no. 813/2013				
Heating, average climatic conditions				
– Low temperature applications (W35)		A++	A++	A++
– Medium temperature applications (W55)		A++	A++	A++
DHW heating				
– Draw-off profile XL		A+	A+	A+
Heating performance data in accordance with EU Regulation No. 813/2013 (average climatic conditions)				
Low temperature applications (W35)				
– Energy efficiency η_s	%	186	201	206
– Rated heating output P_{rated}	kW	7.0	8.0	12.0
– Seasonal coefficient of performance (SCOP)		4.84	5.24	5.34
Medium temperature applications (W55)				
– Energy efficiency η_s	%	134	144	145
– Rated heating output P_{rated}	kW	6.0	7.0	10.0
– Seasonal coefficient of performance (SCOP)		3.56	3.80	3.83
– DHW heating energy efficiency η_{wh}	%	130	130	130
Sound power level to ErP				
	dB(A)	40	44	46

Vitocal 222-G, type BWT 221.B06 to B10 (cont.)

Dimensions

Primary circuit connections to the right

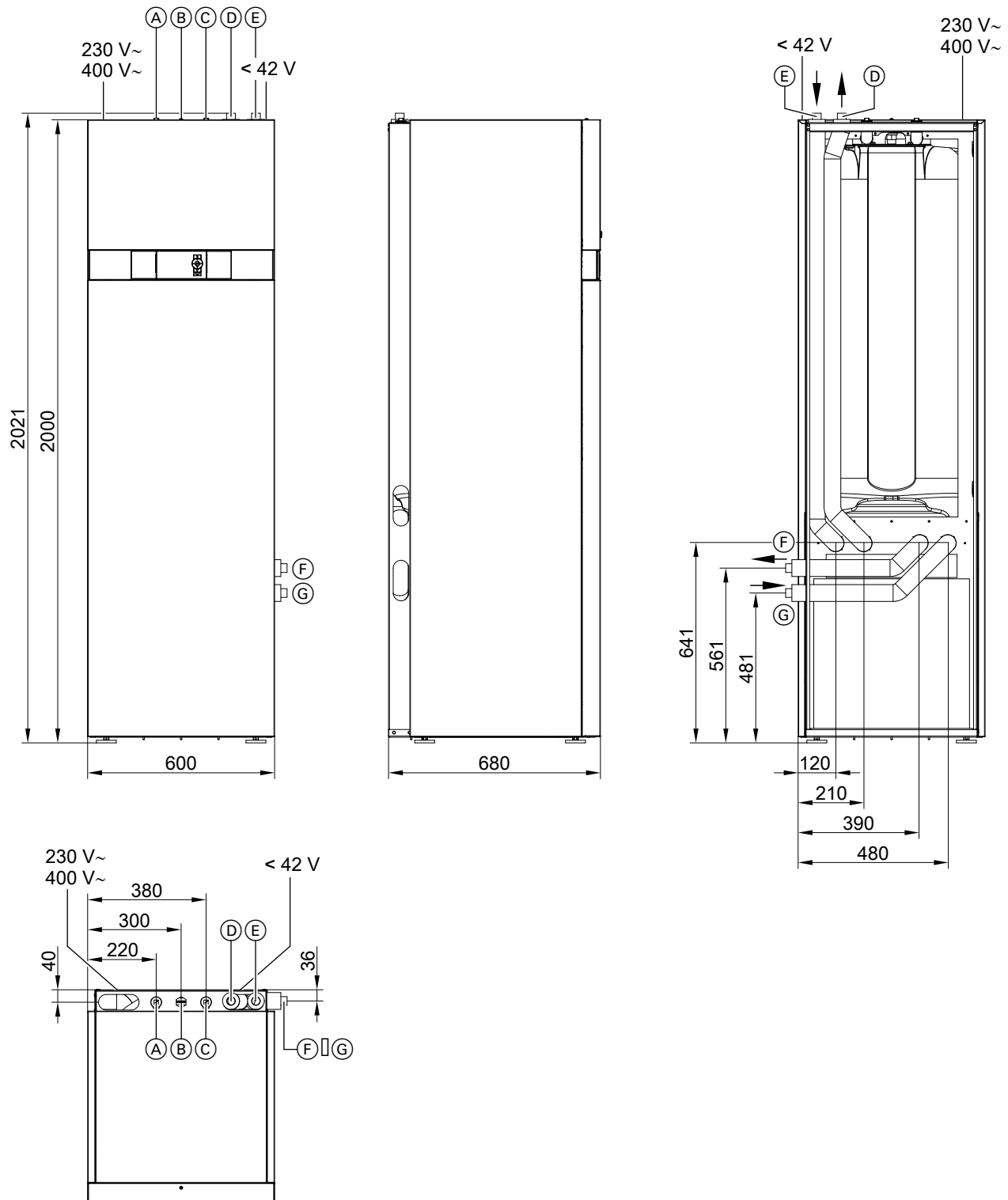

- (A) Cold water
- (B) DHW circulation
- (C) DHW
- (D) Secondary circuit flow (heating water)
- (E) Secondary circuit return (heating water)
- (F) Primary circuit return (heat pump brine outlet)
- (G) Primary circuit flow (heat pump brine inlet)

Vitocal 222-G, type BWT 221.B06 to B10 (cont.)

Primary circuit connections to the left

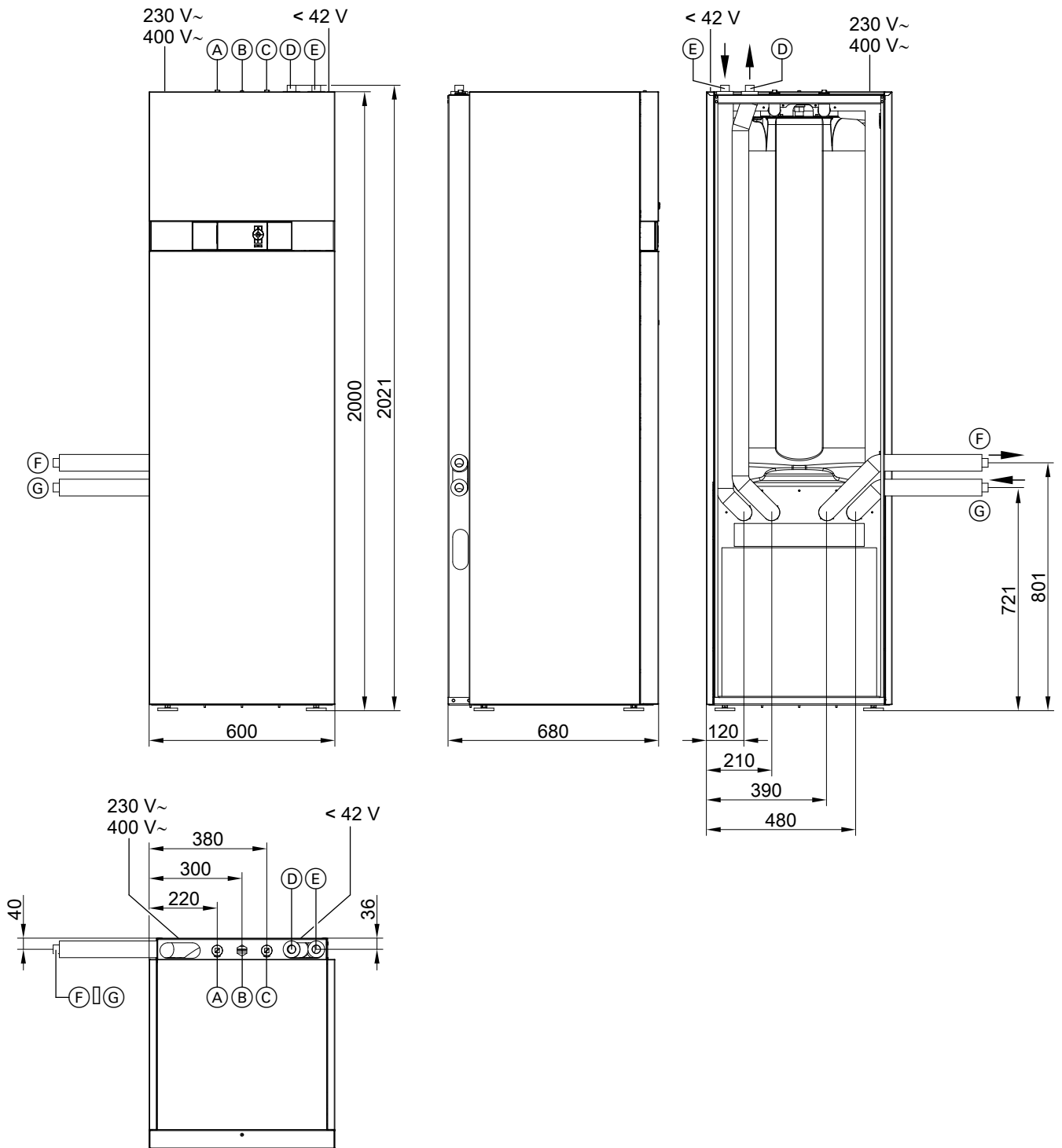

- (A) Cold water
- (B) DHW circulation
- (C) DHW

- (D) Secondary circuit flow (heating water)
- (E) Secondary circuit return (heating water)
- (F) Primary circuit return (heat pump brine outlet)
- (G) Primary circuit flow (heat pump brine inlet)

Application limits to EN 14511

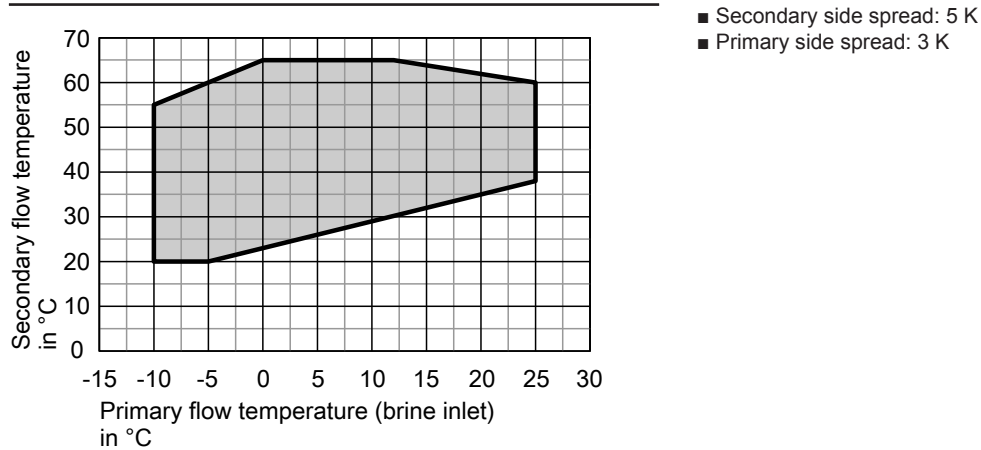

Curves

Output diagrams for type BWT-M 221.B06

Heating output at secondary circuit flow temperatures of 35 °C, 45 °C, 55 °C, 65 °C

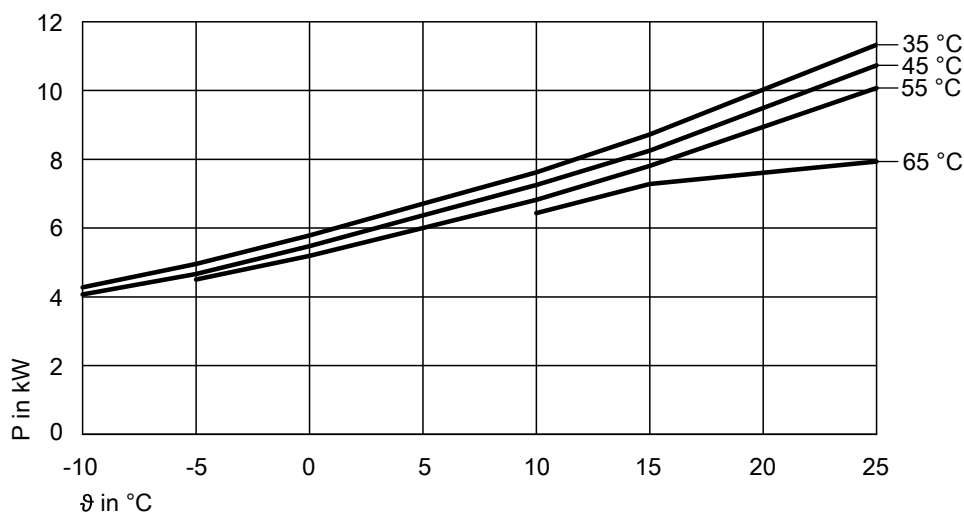

Cooling capacity at secondary circuit flow temperatures of 35 °C, 45 °C, 55 °C, 65 °C

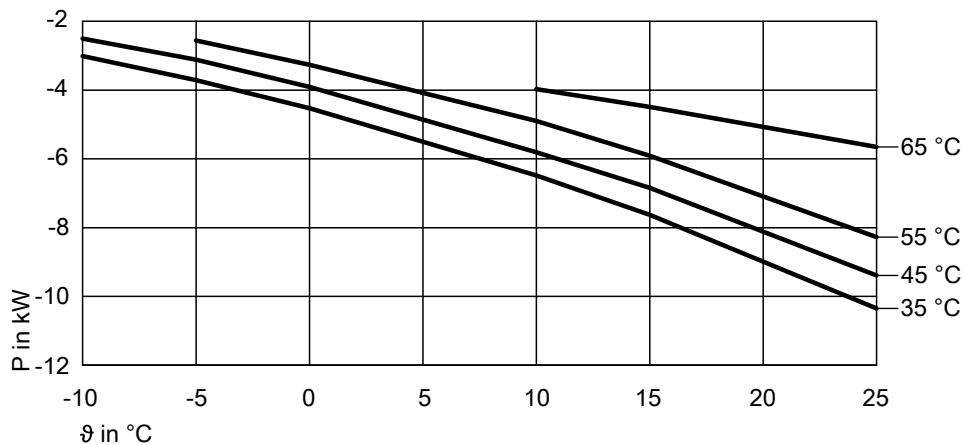

Vitocal 222-G, type BWT 221.B06 to B10 (cont.)

Power consumption at secondary circuit flow temperatures of 35 °C, 45 °C, 55 °C, 65 °C

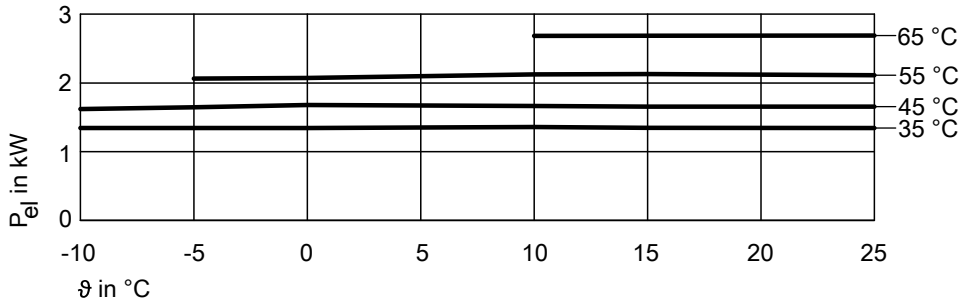

Coefficient of performance (COP) at secondary circuit flow temperatures of 35 °C, 45 °C, 55 °C, 65 °C

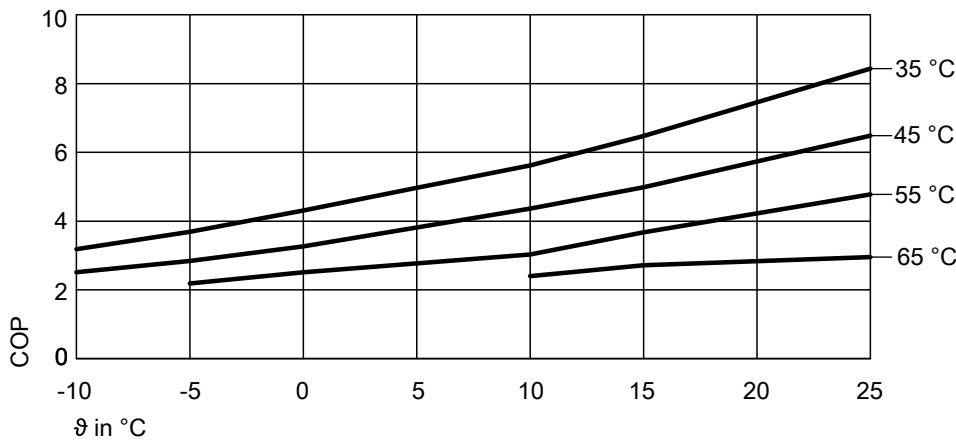

ϑ Primary circuit flow temperature (heat pump brine inlet)
 P Heating output or cooling capacity
 P_{el} Power consumption
 COP Coefficient of performance

Note

- The COP data in the tables and diagrams was calculated with reference to EN 14511.
- Performance characteristics apply to new appliances with clean plate heat exchangers.

Operating point	W B	°C °C	35						
			-10	-5	0	5	10	15	25
Heating output		kW	4.28	4.96	5.79	6.71	7.62	8.72	11.33
Cooling capacity		kW	3.01	3.71	4.53	5.51	6.48	7.63	10.35
Power consumption		kW	1.34	1.34	1.34	1.35	1.36	1.35	1.34
Coefficient of performance ε (COP)			3.18	3.69	4.31	4.96	5.61	6.47	8.43

Operating point	W B	°C °C	45						
			-10	-5	0	5	10	15	25
Heating output		kW	4.07	4.67	5.47	6.36	7.26	8.25	10.73
Cooling capacity		kW	2.51	3.12	3.91	4.86	5.81	6.84	9.39
Power consumption		kW	1.62	1.64	1.68	1.67	1.66	1.66	1.66
Coefficient of performance ε (COP)			2.51	2.84	3.26	3.81	4.36	4.98	6.48

Operating point	W B	°C °C	55						
			-10	-5	0	5	10	15	25
Heating output		kW		4.50	5.19	6.01	6.82	7.81	10.07
Cooling capacity		kW		2.56	3.27	4.08	4.90	5.91	8.28
Power consumption		kW		2.06	2.07	2.10	2.12	2.13	2.11
Coefficient of performance ε (COP)				2.18	2.51	2.77	3.03	3.67	4.77

Operating point	W B	°C °C	65						
			-10	-5	0	5	10	15	25
Heating output		kW					6.43	7.29	7.94
Cooling capacity		kW					3.98	4.49	5.66
Power consumption		kW					2.68	2.69	2.69
Coefficient of performance ε (COP)							2.40	2.71	2.95

5822541

Vitocal 222-G, type BWT 221.B06 to B10 (cont.)

Residual heads of the integral circulation pumps, type BWT-M 221.B06

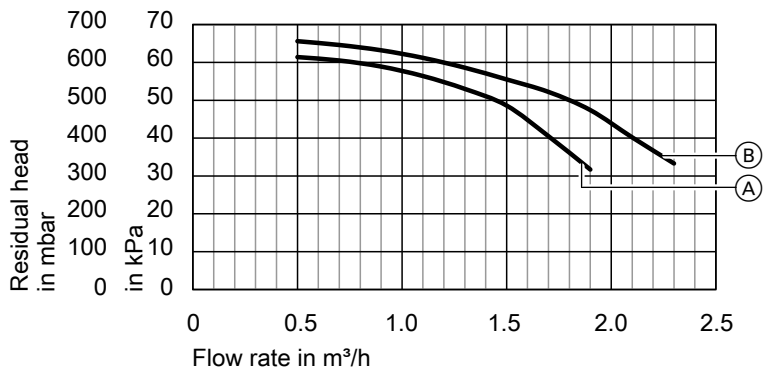

- (A) Secondary pump (Grundfos UPM3 25-75 130 PWM)
- (B) Primary pump (Wilo Yonos PARA GT 25/7.5 130 PWM)

Output diagrams for type BWT-M 221.B08

Heating output at secondary circuit flow temperatures of 35 °C, 45 °C, 55 °C, 65 °C

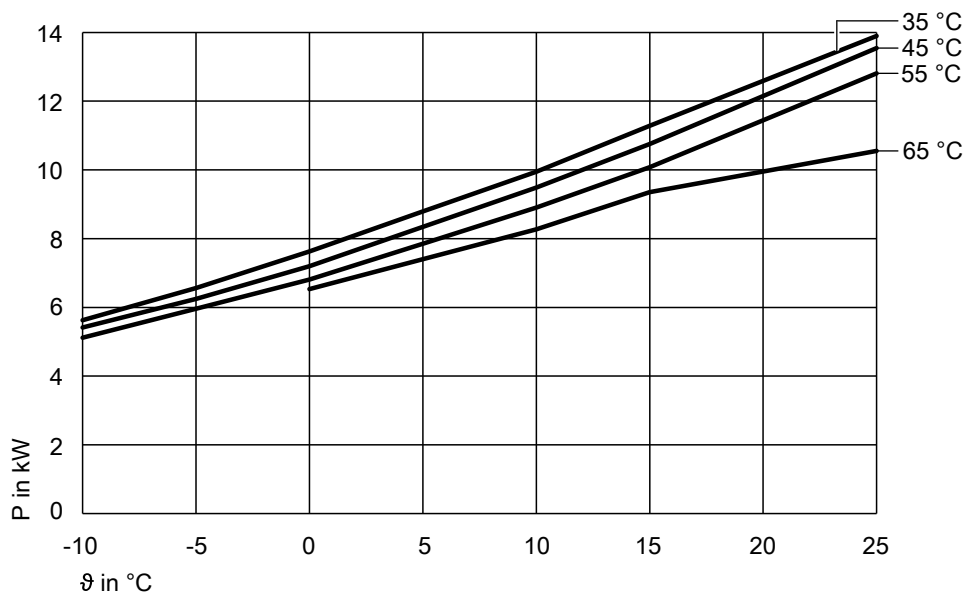

Vitocal 222-G, type BWT 221.B06 to B10 (cont.)

Cooling capacity at secondary circuit flow temperatures of 35 °C, 45 °C, 55 °C, 65 °C

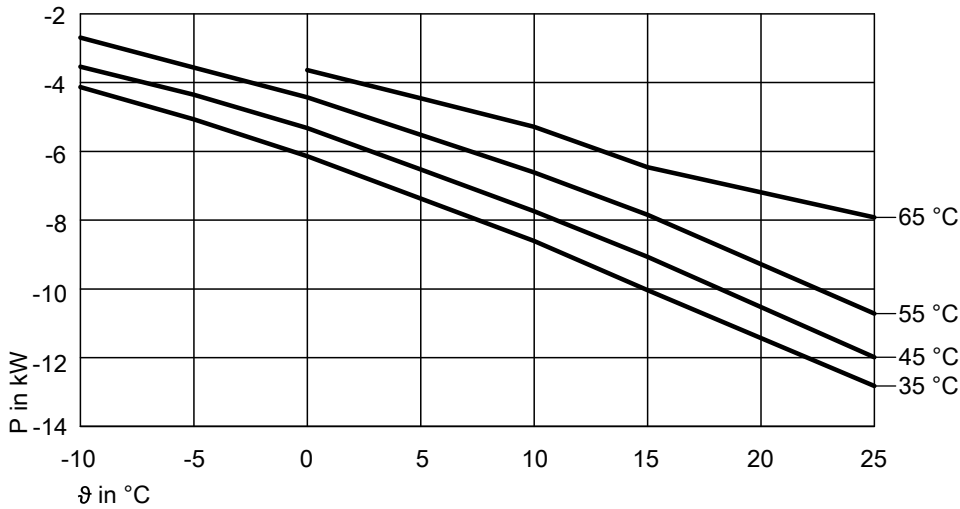

Power consumption at secondary circuit flow temperatures of 35 °C, 45 °C, 55 °C, 65 °C

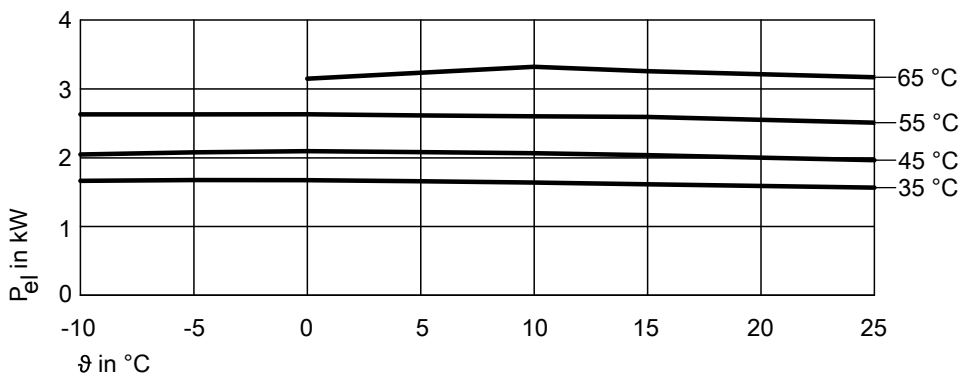

Coefficient of performance (COP) at secondary circuit flow temperatures of 35 °C, 45 °C, 55 °C, 65 °C

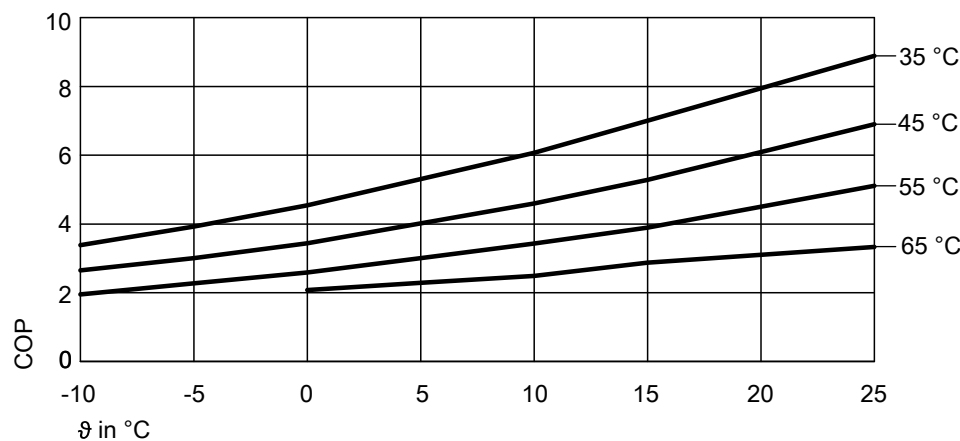

ϑ Primary circuit flow temperature (heat pump brine inlet)
 P Heating output or cooling capacity
 P_{el} Power consumption
 COP Coefficient of performance

Note

- The COP data in the tables and diagrams was calculated with reference to EN 14511.
- Performance characteristics apply to new appliances with clean plate heat exchangers.

5822541

Vitocal 222-G, type BWT 221.B06 to B10 (cont.)

Operating point	W B	°C °C	35						
			-10	-5	0	5	10	15	25
Heating output		kW	5.63	6.57	7.63	8.79	9.95	11.29	13.90
Cooling capacity		kW	4.13	5.07	6.15	7.37	8.60	10.03	12.83
Power consumption		kW	1.66	1.67	1.67	1.66	1.64	1.61	1.56
Coefficient of performance ϵ (COP)			3.38	3.92	4.54	5.31	6.07	7.00	8.89

Operating point	W B	°C °C	45						
			-10	-5	0	5	10	15	25
Heating output		kW	5.42	6.24	7.20	8.34	9.48	10.75	13.55
Cooling capacity		kW	3.54	4.36	5.33	6.53	7.74	9.07	11.99
Power consumption		kW	2.05	2.08	2.09	2.08	2.07	2.04	1.96
Coefficient of performance ϵ (COP)			2.65	3.01	3.44	4.01	4.59	5.28	6.90

Operating point	W B	°C °C	55						
			-10	-5	0	5	10	15	25
Heating output		kW	5.12	5.96	6.81	7.86	8.90	10.08	12.81
Cooling capacity		kW	2.69	3.56	4.43	5.52	6.61	7.84	10.72
Power consumption		kW	2.63	2.63	2.63	2.61	2.60	2.59	2.51
Coefficient of performance ϵ (COP)			1.95	2.27	2.59	3.01	3.43	3.89	5.11

Operating point	W B	°C °C	65						
			-10	-5	0	5	10	15	25
Heating output		kW			6.53	7.40	8.27	9.36	10.56
Cooling capacity		kW			3.64	4.46	5.28	6.46	7.92
Power consumption		kW			3.15	3.23	3.32	3.26	3.17
Coefficient of performance ϵ (COP)					2.08	2.28	2.49	2.87	3.33

Residual heads of the integral circulation pumps, type BWT-M 221.B08

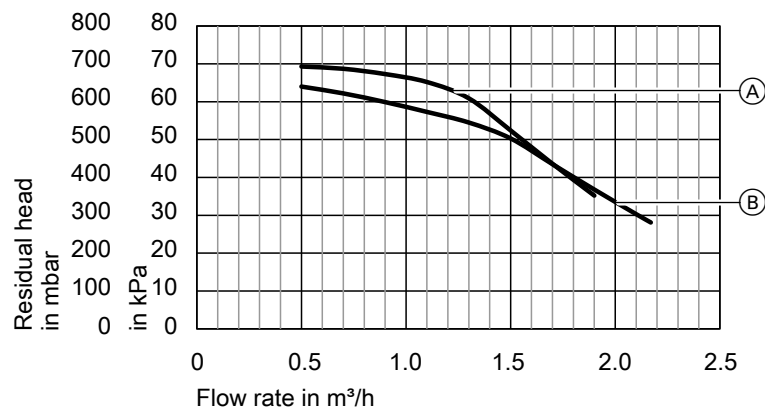

- (A) Secondary pump (Grundfos UPM3 25-75 130 PWM)
- (B) Primary pump (Wilo Yonos PARA GT 25/7.5 130 PWM)

Vitocal 222-G, type BWT 221.B06 to B10 (cont.)

Output diagrams for type BWT-M 221.B10

Heating output at secondary circuit flow temperatures of 35 °C, 45 °C, 55 °C, 65 °C

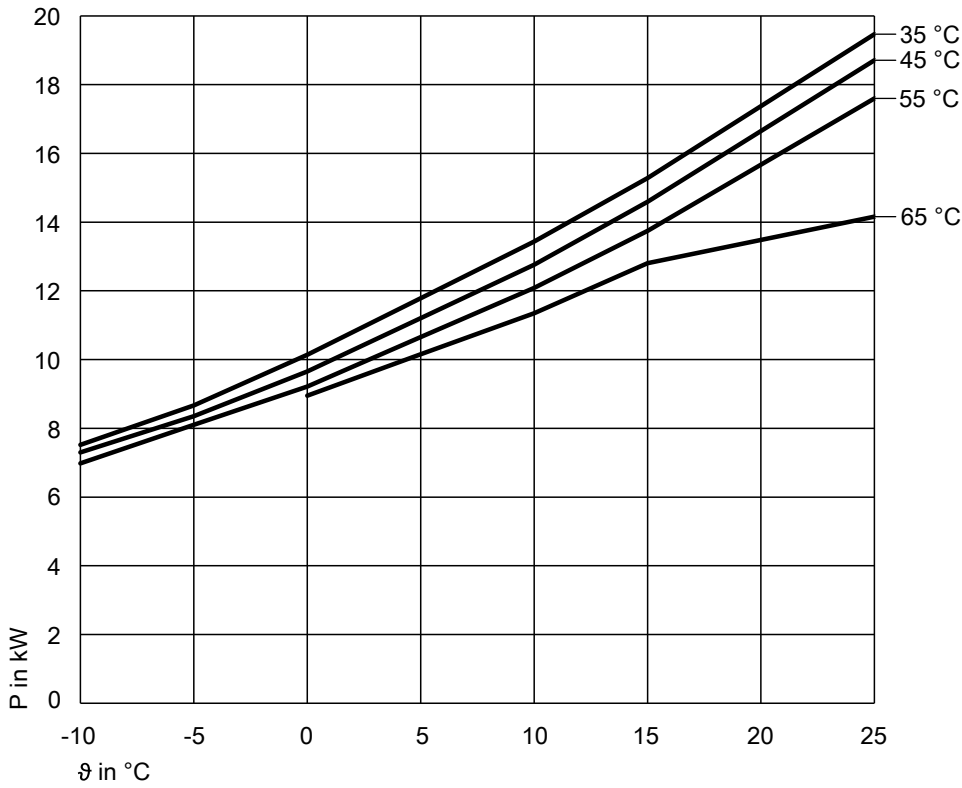

Cooling capacity at secondary circuit flow temperatures of 35 °C, 45 °C, 55 °C, 65 °C

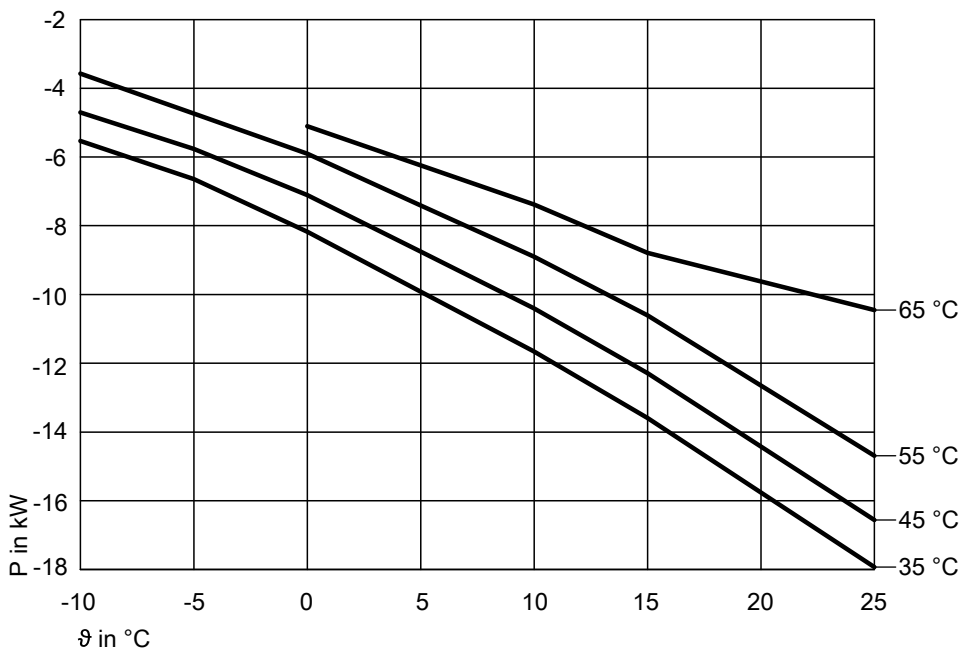

Vitocal 222-G, type BWT 221.B06 to B10 (cont.)

Power consumption at secondary circuit flow temperatures of 35 °C, 45 °C, 55 °C, 65 °C

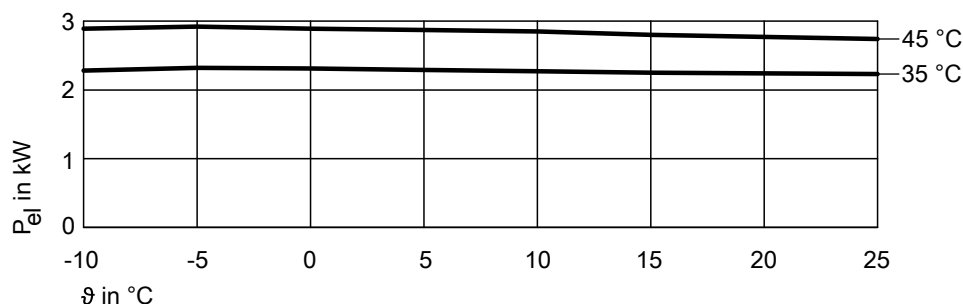

Coefficient of performance (COP) at secondary circuit flow temperatures of 35 °C, 45 °C, 55 °C, 65 °C

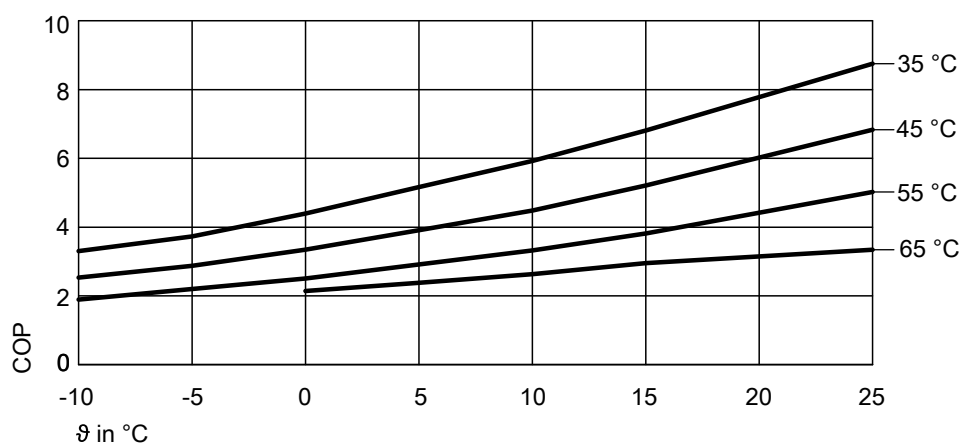

ϑ Primary circuit flow temperature (heat pump brine inlet)
 P Heating output or cooling capacity
 P_{el} Power consumption
 COP Coefficient of performance

Note

- The COP data in the tables and diagrams was calculated with reference to EN 14511.
- Performance characteristics apply to new appliances with clean plate heat exchangers.

Operating point	W B	°C °C	35						
			-10	-5	0	5	10	15	25
Heating output		kW	7.52	8.66	10.14	11.79	13.44	15.29	19.47
Cooling capacity		kW	5.53	6.64	8.17	9.92	11.66	13.59	17.93
Power consumption		kW	2.28	2.32	2.31	2.29	2.27	2.25	2.23
Coefficient of performance ε (COP)			3.3	3.73	4.39	5.16	5.92	6.81	8.75

Operating point	W B	°C °C	45						
			-10	-5	0	5	10	15	25
Heating output		kW	7.3	8.36	9.65	11.2	12.76	14.59	18.71
Cooling capacity		kW	4.7	5.76	7.11	8.75	10.4	12.28	16.56
Power consumption		kW	2.89	2.92	2.89	2.87	2.85	2.8	2.74
Coefficient of performance ε (COP)			2.53	2.87	3.34	3.91	4.48	5.21	6.83

Operating point	W B	°C °C	55						
			-10	-5	0	5	10	15	25
Heating output		kW	6.98	8.1	9.21	10.65	12.08	13.74	17.6
Cooling capacity		kW	3.57	4.73	5.9	7.4	8.9	10.61	14.69
Power consumption		kW	3.69	3.69	3.69	3.67	3.64	3.61	3.51
Coefficient of performance ε (COP)			1.89	2.2	2.5	2.91	3.32	3.81	5.02

Operating point	W B	°C °C	65						
			-10	-5	0	5	10	15	25
Heating output		kW			8.95	10.15	11.34	12.81	14.16
Cooling capacity		kW			5.1	6.24	7.38	8.79	10.45
Power consumption		kW			4.19	4.25	4.31	4.34	4.24
Coefficient of performance ε (COP)					2.14	2.38	2.63	2.95	3.34

Vitocal 222-G, type BWT 221.B06 to B10 (cont.)

Residual heads of the integral circulation pumps, type BWT-M 221.B10

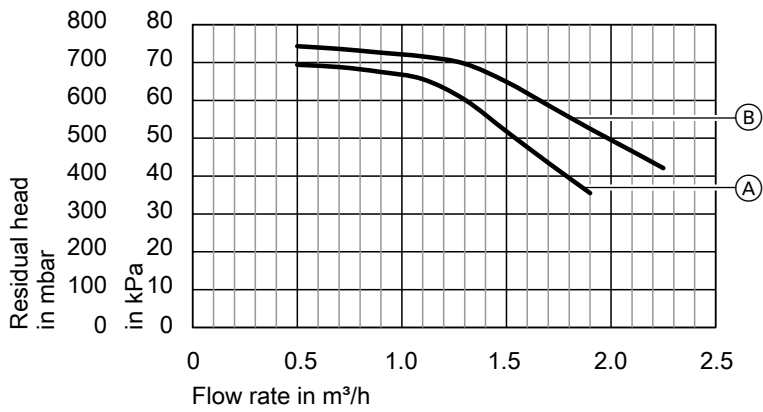

- Ⓐ Secondary pump (Grundfos UPM3 25-75 130 PWM)
- Ⓑ Primary pump (Wilo Yonos PARA GT 25/7.5 130 PWM)

7.1 Product description

Benefits

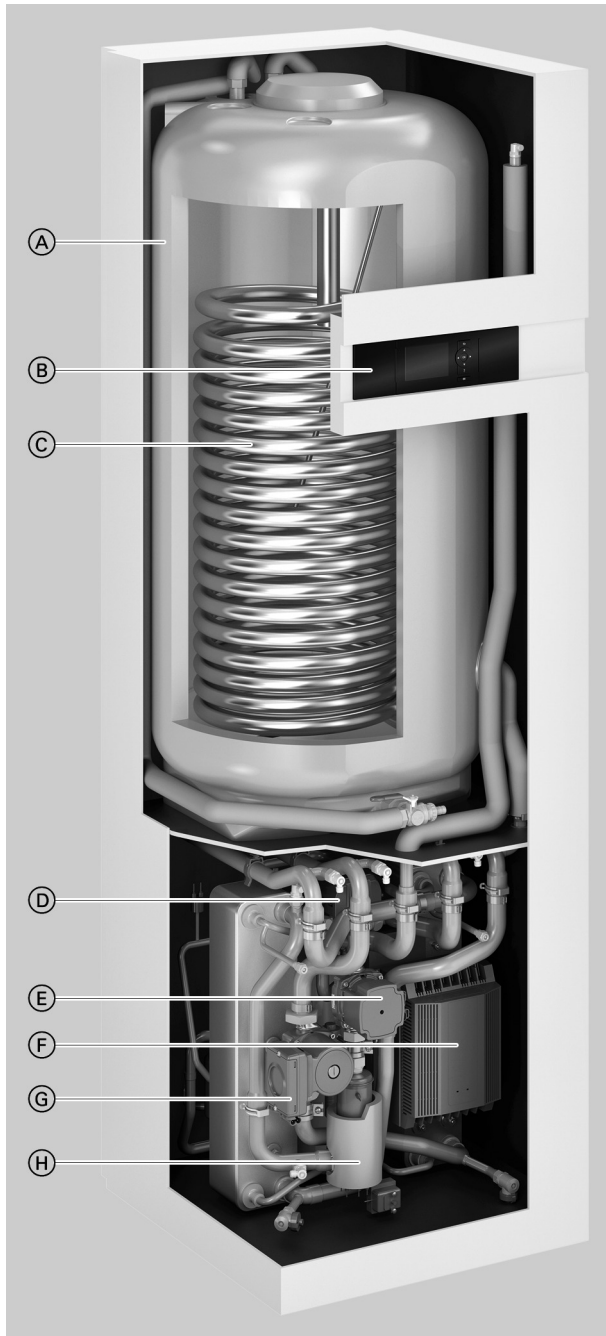

- Ⓐ DHW cylinder with 220 l capacity
- Ⓑ Vitotronic 200 weather-compensated, digital heat pump control unit
- Ⓒ Indirect coil for cylinder heating
- Ⓓ 3-way diverter valve for central heating/DHW heating
- Ⓔ Secondary pump (heating water), high efficiency circulation pump
- Ⓕ Compressor output control, switched via inverter
- Ⓖ Primary pump (brine), high efficiency circulation pump
- Ⓗ Instantaneous heating water heater

7

- Low operating costs thanks to high COP to EN 14511: Up to 4.8. (B0/W35)
- Maximum flow temperatures of up to 65 °C for high DHW convenience
- Especially quiet thanks to new sound insulation concept: 33 to 46 dB(A) (B0/W55)
- Very low operating costs thanks to output-controlled refrigerant circuit with innovative inverter technology for maximum seasonal efficiency: SCOP (seasonal coefficient of performance) up to 5.5 (cold climate/low temperature application)
- DHW temperature in the DHW cylinder up to 60 °C (without use of the integral instantaneous heating water heater)

- High DHW convenience (A+ energy label) and very high draw-off rates (306 l)
- Easy to operate Vitotronic control unit with plain text and graphic display
- Easy handling as the heat pump module can be quickly removed thanks to push-fit connections
- Optimised utilisation of power generated on-site by a photovoltaic system
- Control of compatible Vitovent ventilation units
- Web-enabled through Vitoconnect (accessories) for operation and service via Viessmann apps

Delivered condition

- Brine/water heat pump for central heating and DHW heating
- Integral steel DHW cylinder with Ceraprotect enamel coating, protected from corrosion by a protective magnesium anode, with thermal insulation
- Integral diverter valve for central heating/DHW heating
- Integral high efficiency circulation pump for primary circuit (brine)
- Integral high efficiency circulation pump for secondary circuit (heating water)
- Integral instantaneous heating water heater
- Safety assembly for the heating circuit (supplied)
- Vitotronic 200 weather-compensated heat pump control unit with outside temperature sensor
- Integral phase monitoring
- Connection lines for primary circuit (brine) flow and return can be connected on the left or right (supplied)
- Connection lines for secondary circuit (heating water) flow and return for connection at the top (supplied)

7.2 Specification

Specification

Type BWT		331.C06	331.C12
Performance data to EN 14511 (B0/W35, 5 K spread)			
Rated heating output	kW	4.28	5.31
Cooling capacity	kW	3.45	4.35
Power consumption	kW	0.91	1.10
Coefficient of performance ϵ (COP)		4.70	4.80
Heating modulation range, min. to max.		1.7 to 8.6	2.4 to 11.4
Brine (primary circuit)			
Capacity	l	3.7	4.2
Minimum flow rate	l/h	900	1000
Nominal flow rate	l/h	1070	1300
Residual head at minimum flow rate	mbar	800	680
	kPa	80	68
Residual head at nominal flow rate	mbar	780	620
	kPa	78	62
Max. flow temperature (brine inlet)	°C	25	25
Min. flow temperature (brine inlet)	°C	-10	-10
Heating water (secondary circuit)			
Capacity, heat pump	l	4.5	5.3
Capacity, total	l	16.5	17.3
Minimum flow rate	l/h	600	720
Nominal flow rate	l/h	740	920
Residual head at minimum flow rate	mbar	710	700
	kPa	71	70
Residual head at nominal flow rate	mbar	700	680
	kPa	70	68
Max. flow temperature	°C	65	65
Instantaneous heating water heater			
Heating output	kW	9.0	
Rated voltage		3/N/PE 400 V/50 Hz	
Fuse rating		3 x B16 A 1-pole	
Heat pump electrical values			
Rated voltage, compressor		3/N/PE 400 V/50 Hz	
Rated current, compressor	A	9.0	12.0
Cos ϕ		0.9	0.9
Starting current, compressor	A	9	12
Starting current, compressor with stalled armature	A	9	12
Compressor fuse rating	A	1 x B16 A 3-pole	1 x B16 A 3-pole
Rated voltage, heat pump control unit/PCB		1/N/PE 230 V/50 Hz	
Fuse rating, heat pump control unit/PCB (internal)		6.3 A (slow) / 250 V	
Power consumption			
Primary pump (high efficiency circulation pump)	W	25 to 87	
– Energy efficiency index EEI		≤ 0.21	
Secondary pump (high efficiency circulation pump)	W	8 to 59	
– Energy efficiency index EEI		≤ 0.21	
Max. power consumption, control unit	W	1000	
Rated output, control unit/PCB	W	12	
Refrigerant circuit			
Refrigerant		R410A	R410A
– Refrigerant charge	kg	2.0	2.3
– Global warming potential (GWP) ^{*7}		1924	1924
– CO ₂ equivalent	t	3.9	4.6
Permiss. operating pressure	– High pressure side	bar	45
		MPa	4.5
– Low pressure side		bar	28
		MPa	2.8
Compressor	Type	Hermetically sealed scroll compressor	
Oil in compressor	Type	Emkarate RL32-3MAF	
Quantity of oil in compressor	l	0.74	0.74
Oil quantity in oil separator	l	0.4	0.4

^{*7} Based on the Fifth Assessment Report of the Intergovernmental Panel on Climate Change (IPCC).

Vitocal 333-G, type 331.C06 to C12 (cont.)

Type BWT		331.C06	331.C12
Integral DHW cylinder			
Capacity	l	220	220
Max. draw-off volume at DHW temperature 40 °C, storage temperature 53 °C and draw-off rate 10 l/min	l	306	306
Max. DHW temperature			
– Only with heat pump	°C	60	60
– With instantaneous heating water heater	°C	65	65
Max. permiss. DHW temperature	°C	95	95
Dimensions			
Total length	mm	680	680
Total width	mm	600	600
Total height	mm	2000	2000
Weight			
Total weight	kg	277	282
Heat pump module	kg	78	83
Permiss. operating pressure			
Primary circuit (brine)	bar	3.0	3.0
	MPa	0.3	0.3
Secondary circuit, heating water	bar	3.0	3.0
	MPa	0.3	0.3
Secondary circuit, DHW	bar	10.0	10.0
	MPa	1.0	1.0
Connections			
Primary circuit flow/return	mm	Cu 28 x 1.5	Cu 28 x 1.5
Secondary circuit flow/return	mm	Cu 28 x 1.5	Cu 28 x 1.5
Cold water, DHW (female thread)	Rp	¾	¾
DHW circulation (female thread)	Rp	¾	¾
Sound power (measured with reference to EN 12102/EN ISO 9614-2)			
Weighted total sound power level for B0 ^{±3} K/W35 ^{±5} K			
– At rated heating output	dB(A)	39	40
Weighted total sound power level for B0 ^{±3} K/W55 ^{±5} K			
– Weighted total sound power level, min. to max.	dB(A)	30 to 47	33 to 46
– In quiet mode	dB(A)	34	39
Energy efficiency class to Commission Regulation (EU) No 813/2013			
Heating, average climatic conditions			
– Low temperature applications (W35)		A+++*8	A+++*8
– Medium temperature applications (W55)		A++	A+++*8
Heating performance data in accordance with Commission Regulation (EU) No 813/2013 (average climatic conditions)			
Low temperature applications (W35)			
– Energy efficiency η_s	%	209	213
– Rated heating output P_{rated}	kW	6	12
– Seasonal coefficient of performance (SCOP)		5.43	5.52
Medium temperature applications (W55)			
– Energy efficiency η_s	%	151	157
– Rated heating output P_{rated}	kW	6	12
– Seasonal coefficient of performance (SCOP)		4.00	4.10
– DHW heating energy efficiency η_{wh}	%	130	130
Sound power level to ErP (B0/W55)	dB(A)	40	41

Vitocal 333-G, type 331.C06 to C12 (cont.)

Dimensions

Primary circuit connections to the right

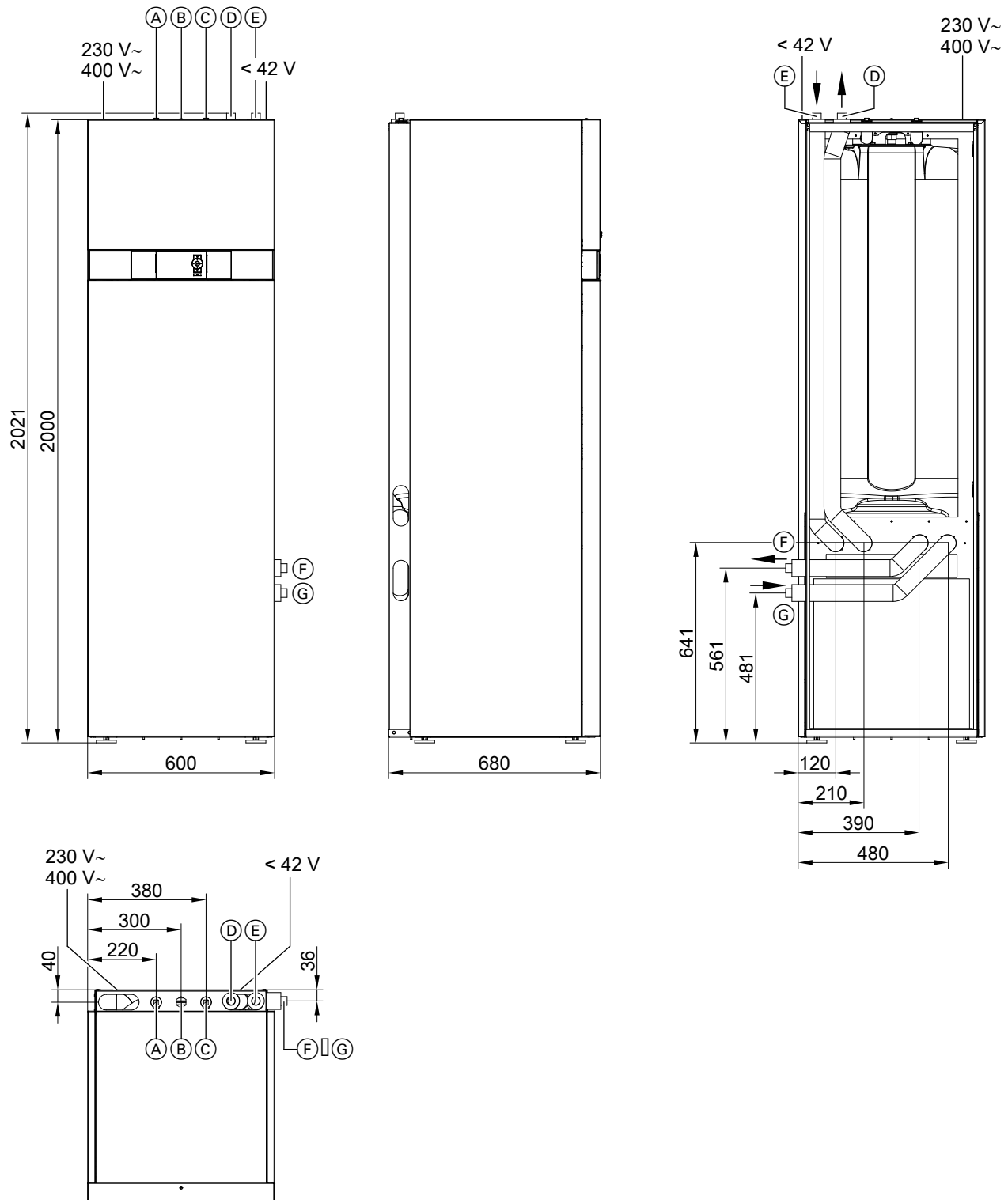

- (A) Cold water
- (B) DHW circulation
- (C) DHW
- (D) Secondary circuit flow (heating water)
- (E) Secondary circuit return (heating water)
- (F) Primary circuit return (heat pump brine outlet)
- (G) Primary circuit flow (heat pump brine inlet)

Vitocal 333-G, type 331.C06 to C12 (cont.)

Primary circuit connections to the left

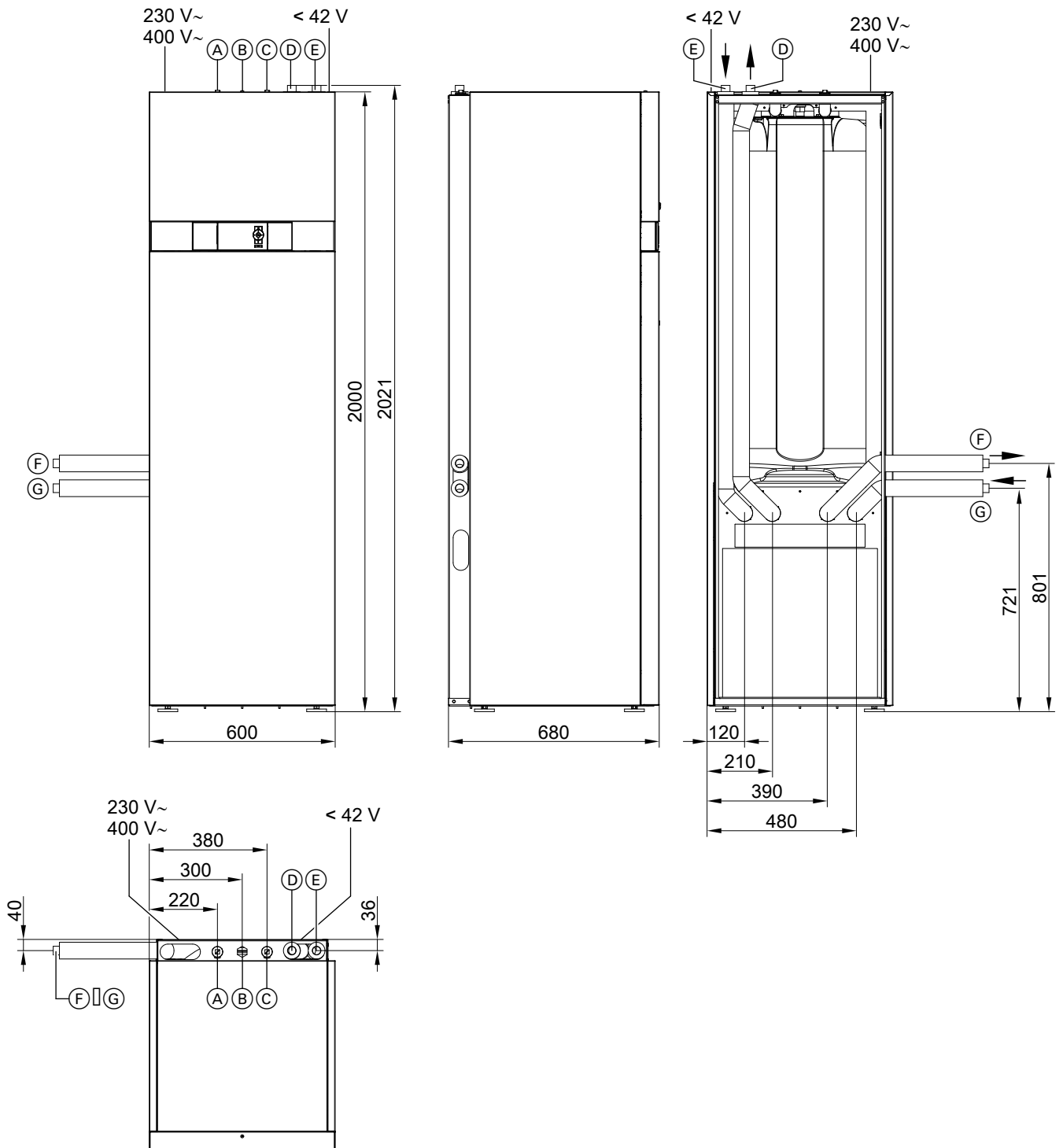

- (A) Cold water
- (B) DHW circulation
- (C) DHW

- (D) Secondary circuit flow (heating water)
- (E) Secondary circuit return (heating water)
- (F) Primary circuit return (heat pump brine outlet)
- (G) Primary circuit flow (heat pump brine inlet)

Application limits to EN 14511

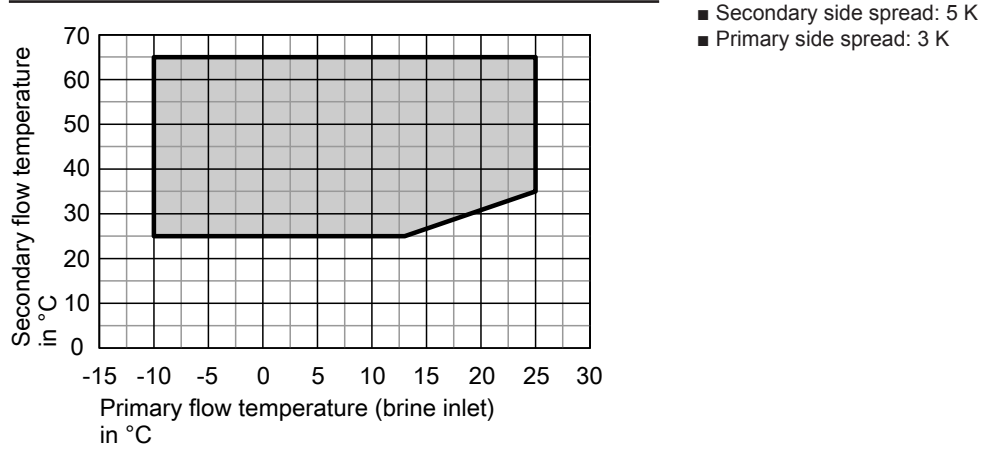

Curves

Output graphs, type BWT 331.C06

Heating output at secondary circuit flow temperatures of 35 °C, 45 °C, 55 °C, 65 °C

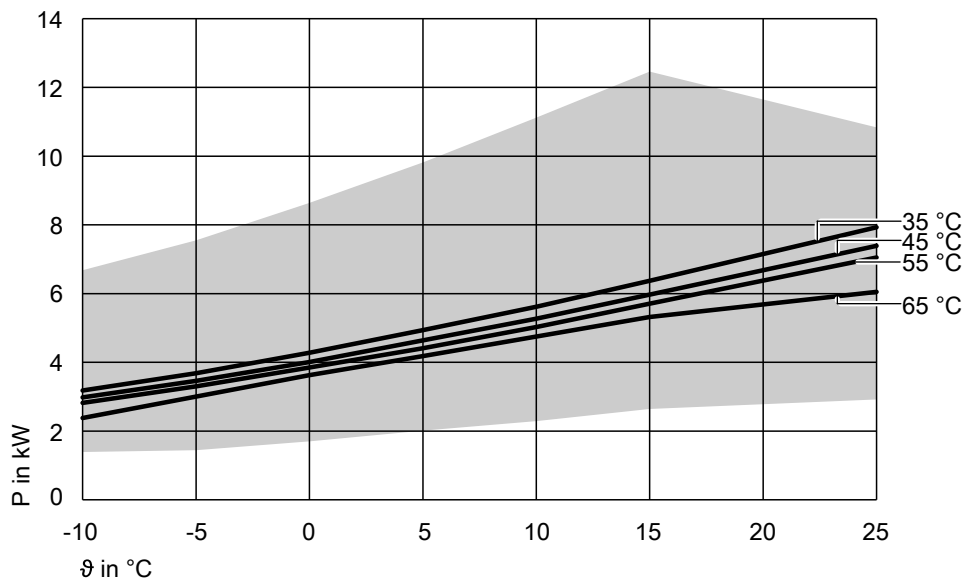

Vitocal 333-G, type 331.C06 to C12 (cont.)

Cooling capacity at secondary circuit flow temperatures of 35 °C, 45 °C, 55 °C, 65 °C

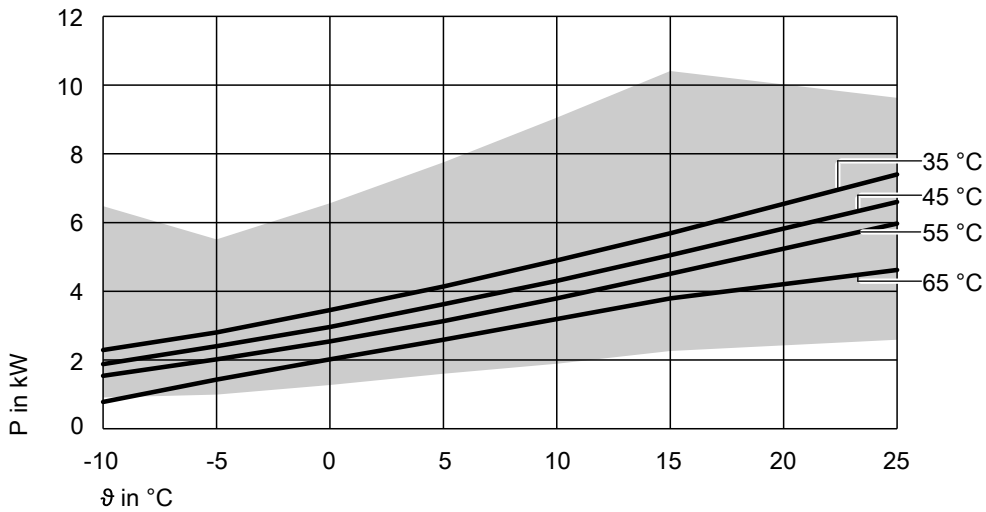

Power consumption at secondary circuit flow temperatures of 35 °C, 45 °C, 55 °C, 65 °C

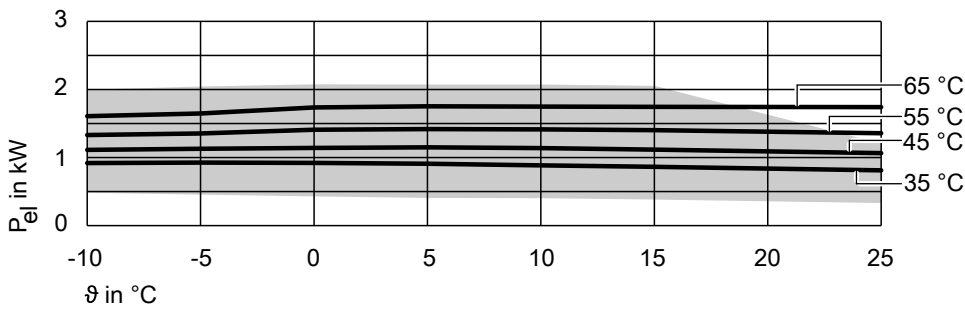

Coefficient of performance (COP) at secondary circuit flow temperatures of 35 °C, 45 °C, 55 °C, 65 °C

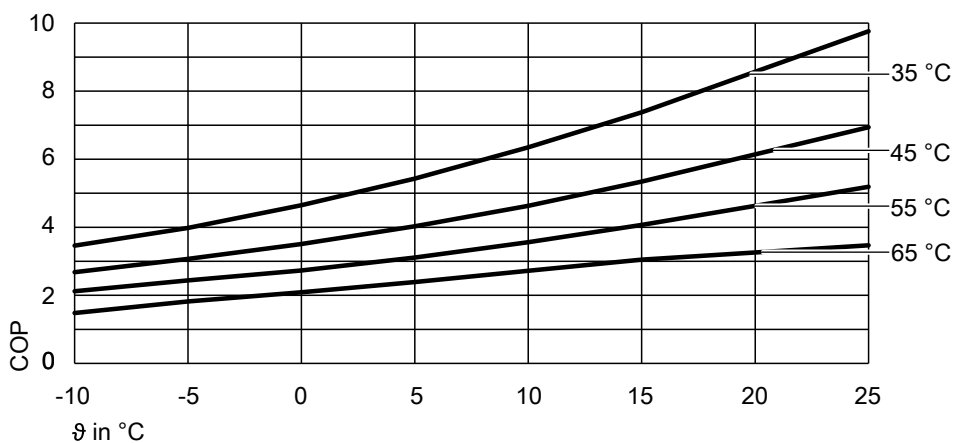

ϑ Primary circuit flow temperature (heat pump brine inlet)
 P Heating output or cooling capacity
 P_{el} Power consumption
 COP Coefficient of performance

Note

- The COP data in the tables and diagrams was calculated with reference to EN 14511.
- Performance characteristics apply to new appliances with clean plate heat exchangers.

■ Possible output range based on a primary circuit flow temperature of 35 °C (heat pump brine inlet)

Vitocal 333-G, type 331.C06 to C12 (cont.)

Operating point	W B	°C °C	35						
			-10	-5	0	5	10	15	25
Max. heating output		kW	6.68	7.55	8.64	9.82	11.12	12.46	10.84
Rated heating output		kW	3.18	3.68	4.28	4.94	5.62	6.37	7.93
Min. heating output		kW	1.39	1.44	1.70	2.01	2.29	2.64	2.92
Max. cooling capacity		kW	6.48	5.51	6.56	7.75	9.05	10.41	9.63
Rated cooling capacity		kW	2.29	2.80	3.45	4.14	4.90	5.69	7.40
Min. cooling capacity		kW	0.91	0.99	1.27	1.60	1.89	2.26	2.59
Max. power consumption		kW	2.00	2.04	2.08	2.07	2.07	2.05	1.21
Rated power consumption		kW	0.92	0.93	0.91	0.91	0.89	0.86	0.81
Min. power consumption		kW	0.48	0.46	0.43	0.41	0.40	0.38	0.33
Max. coefficient of performance ϵ (COP)			3.35	3.70	4.16	4.73	5.36	6.07	8.98
Rated coefficient of performance ϵ (COP)			3.46	3.98	4.70	5.43	6.35	7.38	9.76
Min. coefficient of performance ϵ (COP)			2.88	3.17	3.95	4.93	5.67	6.88	8.78

Operating point	W B	°C °C	45						
			-10	-5	0	5	10	15	25
Heating output		kW	2.98	3.46	4.01	4.64	5.27	5.97	7.39
Cooling capacity		kW	1.88	2.40	2.96	3.62	4.30	5.05	6.60
Power consumption		kW	1.11	1.13	1.14	1.15	1.14	1.12	1.07
Coefficient of performance ϵ (COP)			2.68	3.07	3.51	4.03	4.63	5.34	6.94

Operating point	W B	°C °C	55						
			-10	-5	0	5	10	15	25
Max. heating output		kW	6.24		8.09		10.3		
Rated heating output		kW	2.82	3.30	3.85	4.41	5.03	5.71	7.05
Min. heating output		kW	2.01		2.48		3.16		
Max. cooling capacity		kW	3.69		5.26		7.81		
Rated cooling capacity		kW	1.54	2.02	2.54	3.13	3.79	4.51	5.97
Min. cooling capacity		kW	0.95		1.46		2.30		
Max. power consumption		kW	2.71		2.83		2.89		
Rated power consumption		kW	1.33	1.35	1.41	1.42	1.41	1.40	1.36
Min. power consumption		kW	1.10		1.02		0.99		
Max. coefficient of performance ϵ (COP)			2.31		2.34		3.58		
Rated coefficient of performance ϵ (COP)			2.12	2.44	2.73	3.11	3.56	4.07	5.19
Min. coefficient of performance ϵ (COP)			1.84		1.81		3.18		

Operating point	W B	°C °C	65						
			-10	-5	0	5	10	15	25
Heating output		kW	2.38	3.00	3.63	4.18	4.75	5.32	6.05
Cooling capacity		kW	0.78	1.43	2.02	2.59	3.19	3.79	4.62
Power consumption		kW	1.61	1.65	1.74	1.75	1.75	1.75	1.74
Coefficient of performance ϵ (COP)			1.48	1.82	2.09	2.39	2.72	3.05	3.47

Residual heads of the integral circulation pumps, type BWT 331.C06

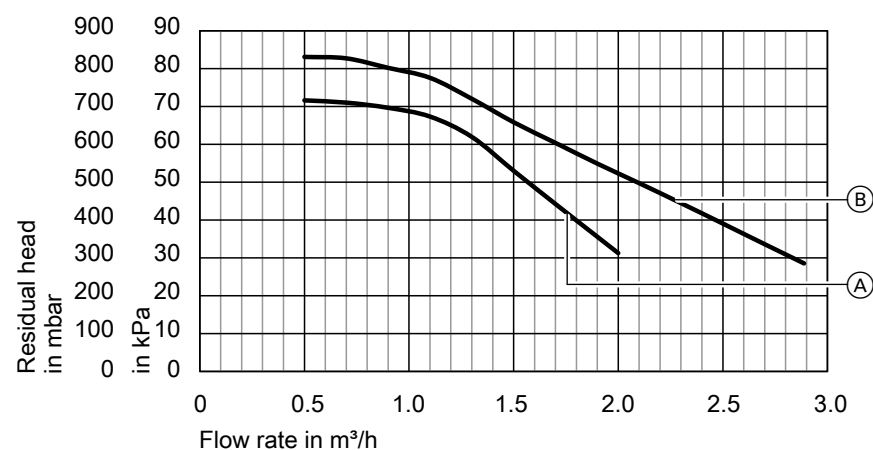

- (A) Secondary pump (Grundfos UPM3 25-75 130 PWM)
 (B) Primary pump (Grundfos UPM3 15-75 130 PWM)

Vitocal 333-G, type 331.C06 to C12 (cont.)

Output graphs, type BWT 331.C12

Heating output at secondary circuit flow temperatures of 35 °C, 45 °C, 55 °C, 65 °C

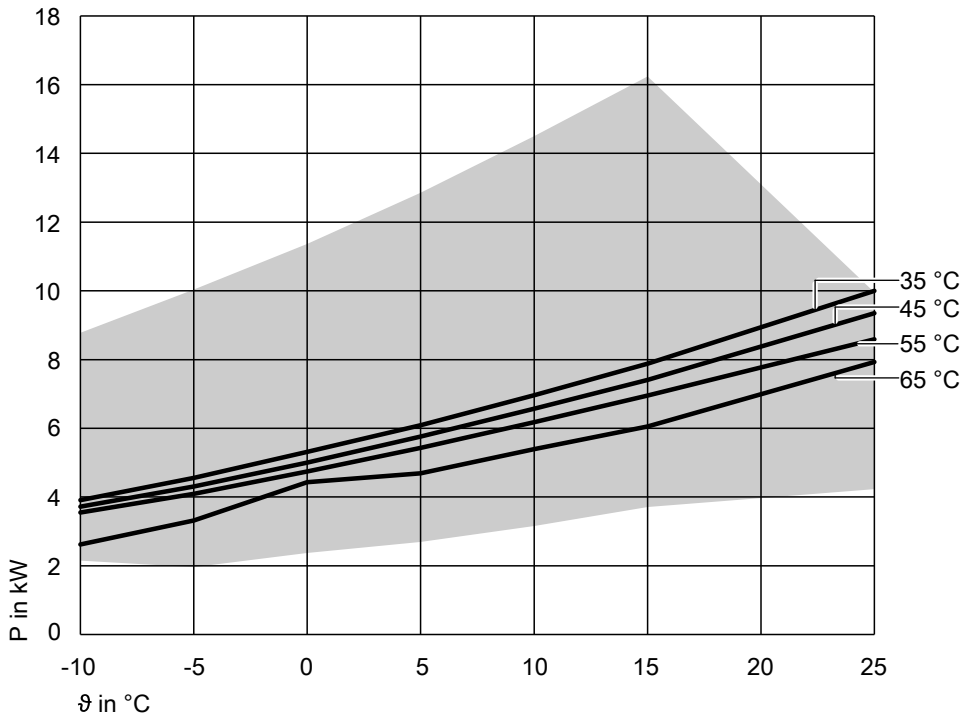

Cooling capacity at secondary circuit flow temperatures of 35 °C, 45 °C, 55 °C, 65 °C

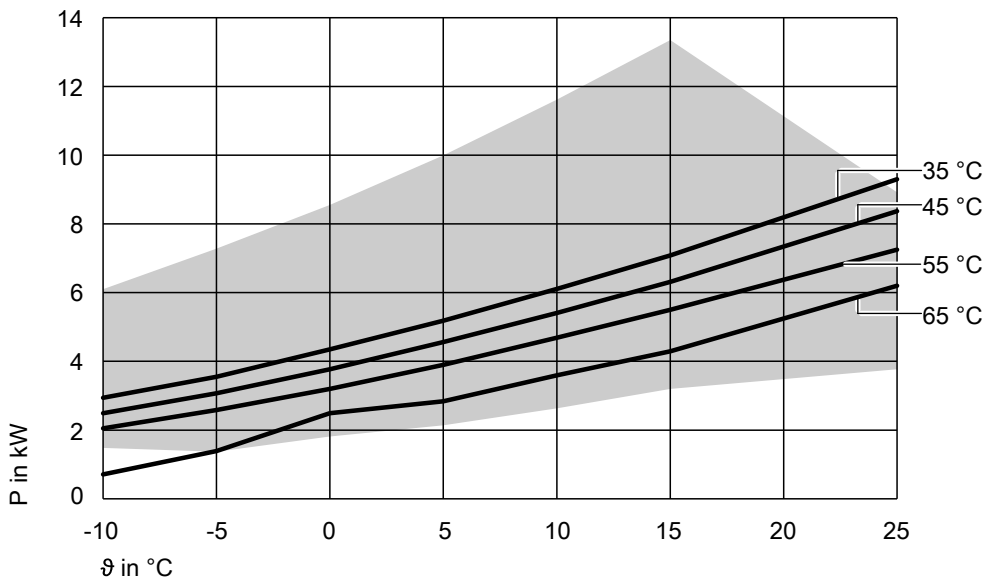

Vitocal 333-G, type 331.C06 to C12 (cont.)

Power consumption at secondary circuit flow temperatures of 35 °C, 45 °C, 55 °C, 65 °C

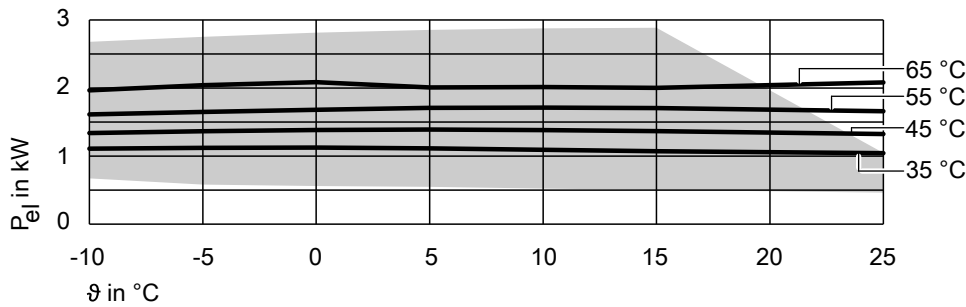

Coefficient of performance (COP) at secondary circuit flow temperatures of 35 °C, 45 °C, 55 °C, 65 °C

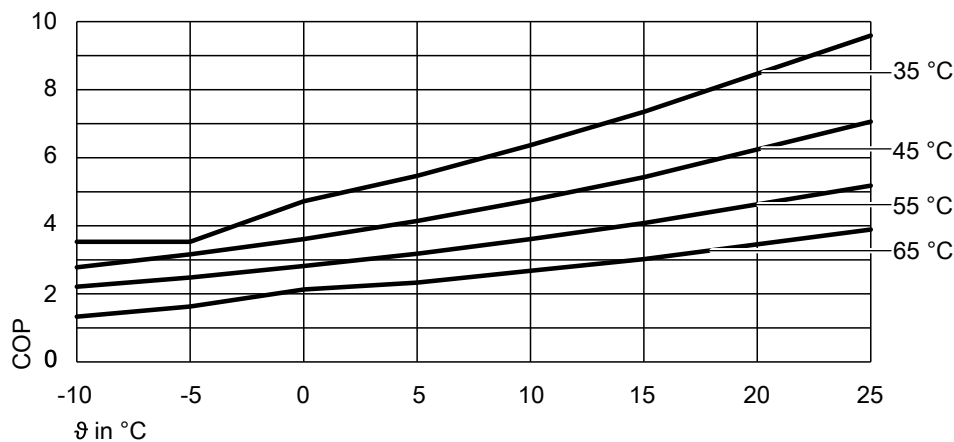

ϑ Primary circuit flow temperature (heat pump brine inlet)
 P Heating output or cooling capacity
 P_{el} Power consumption
 COP Coefficient of performance

Note

- The COP data in the tables and diagrams was calculated with reference to EN 14511.
- Performance characteristics apply to new appliances with clean plate heat exchangers.

■ Possible output range based on a primary circuit flow temperature of 35 °C (heat pump brine inlet)

Operating point	W B	°C °C	35						
			-10	-5	0	5	10	15	25
Max. heating output		kW	8.78	10.04	11.37	12.85	14.50	16.24	10.00
Rated heating output		kW	3.91	4.56	5.31	6.09	6.96	7.88	10.00
Min. heating output		kW	2.15	1.96	2.37	2.69	3.16	3.71	4.23
Max. cooling capacity		kW	6.10	7.28	8.55	9.99	11.62	13.35	9.30
Rated cooling capacity		kW	2.94	3.55	4.35	5.18	6.11	7.08	9.30
Min. cooling capacity		kW	1.48	1.37	1.81	2.14	2.63	3.20	3.77
Max. power consumption		kW	2.68	2.75	2.81	2.85	2.88	2.89	1.04
Rated power consumption		kW	1.11	1.12	1.10	1.11	1.09	1.07	1.04
Min. power consumption		kW	0.67	0.58	0.56	0.55	0.52	0.50	0.46
Max. coefficient of performance ε (COP)			3.28	3.65	4.04	4.50	5.04	5.63	9.59
Rated coefficient of performance ε (COP)			3.53	3.53	4.80	5.47	6.37	7.35	9.59
Min. coefficient of performance ε (COP)			3.20	3.53	4.22	4.91	6.03	7.36	9.14

Operating point	W B	°C °C	45						
			-10	-5	0	5	10	15	25
Heating output		kW	3.72	4.31	5.00	5.76	6.57	7.41	9.35
Cooling capacity		kW	2.49	3.07	3.77	4.56	5.41	6.31	8.37
Power consumption		kW	1.34	1.37	1.38	1.39	1.38	1.37	1.32
Coefficient of performance ε (COP)			2.78	3.16	3.61	4.14	4.75	5.43	7.06

Vitocal 333-G, type 331.C06 to C12 (cont.)

Operating point	W B	°C °C	55							
			-10	-5	0	5	10	15	25	
Max. heating output		kW	8.52		10.83		13.43			
Rated heating output		kW	3.55	4.09	4.74	5.43	6.18	6.95	8.59	
Min. heating output		kW	2.96		3.39		4.37			
Max. cooling capacity		kW	5.14		7.10		9.88			
Rated cooling capacity		kW	2.05	2.58	3.20	3.90	4.69	5.50	7.25	
Min. cooling capacity		kW	1.63		2.10		3.22			
Max. power consumption		kW	3.62		3.73		3.90			
Rated power consumption		kW	1.61	1.65	1.68	1.71	1.71	1.71	1.66	
Min. power consumption		kW	1.40		1.29		1.28			
Max. coefficient of performance ϵ (COP)			2.36		2.90		3.45			
Rated coefficient of performance ϵ (COP)			2.21	2.48	2.82	3.18	3.61	4.08	5.18	
Min. coefficient of performance ϵ (COP)			2.11		2.63		3.41			

Operating point	W B	°C °C	65							
			-10	-5	0	5	10	15	25	
Heating output		kW	2.62	3.32	4.43	4.69	5.39	6.05	7.93	
Cooling capacity		kW	0.71	1.39	2.49	2.84	3.59	4.29	6.20	
Power consumption		kW	1.97	2.04	2.09	2.01	2.01	2.00	2.08	
Coefficient of performance ϵ (COP)			1.33	1.63	2.13	2.33	2.68	3.02	3.89	

Residual heads of the integral circulation pumps, type BWT 331.C12

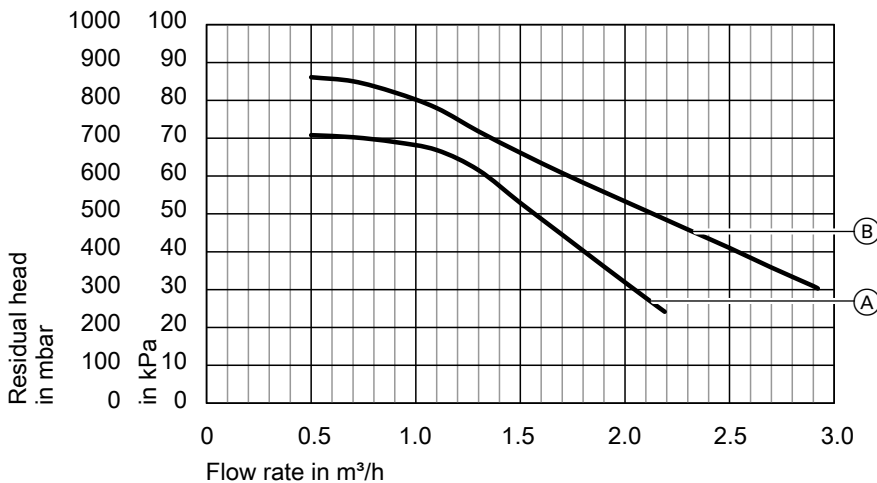

- Ⓐ Secondary pump (Grundfos UPM3 25-75 130 PWM)
- Ⓑ Primary pump (Grundfos UPM3 15-75 130 PWM)

8.1 Overview

Accessories	Part no.	Vitocal				
		200-G BWC 201.A06 to A17	300-G BW, BWS, BWC 301.B06 to B17	300-G BW, BWS 301.A21 to A45 350-G BW, BWS 351.B20 to B42	222-G BWT-M 221.B06 to B10	333-G BWT 331.C06 to C12
Ventilation unit, see from page 85						
Ventilation units and accessories: See "Vitovent" technical guide		X	X		X	X
Brine circuit (primary circuit), see from page 86						
Sensor well set (primary)	7460714		BW+BWS (2-stage)			
Brine accessory pack	ZK02447	X	X	X	X	X
Pump set for brine accessory pack: – With Grundfos high efficiency circulation pump UPM GEO 25/85	ZK02448		BW 301.B06 to B17 (1-stage) BW+BWS 301.B06 to B10 (2-stage)	BW 301.A21 (1-stage)		
– With Grundfos high efficiency circulation pump UPMXL GEO 25/125	ZK02449		BW+BWS 301.B13 to B17 (2-stage)	BW 301.A29 351.B20 (1-stage)		
Brine expansion vessel:						
– 25 l	7248242	X	X		X	X
– 40 l	7248243	X	X	X	X	X
– 50 l	7248244		X	X		
– 80 l	7248245			X		
Pressure switch	9532663	X	X	X	X	X
Brine manifold for geothermal collectors/probes (plas- tic):						
– PE 25 x 2.3 for 2 brine circuits	ZK01285	X	X	X	X	X
– PE 25 x 2.3 for 3 brine circuits	ZK01286	X	X	X	X	X
– PE 25 x 2.3 for 4 brine circuits	ZK01287	X	X	X	X	X
– PE 32 x 2.9 for 2 brine circuits	ZK01288	X	X	X	X	X
– PE 32 x 2.9 for 3 brine circuits	ZK01289	X	X	X	X	X
– PE 32 x 2.9 for 4 brine circuits	ZK01290	X	X	X	X	X
Heat transfer medium:						
– "Tyfocor" 30 l	9532655	X	X	X	X	X
– "Tyfocor" 200 l	9542602	X	X	X	X	X
Filling module	7188625	X	X	X	X	X
Heating circuit (secondary circuit), see from page 94						
Instantaneous heating water heater:	ZK01538 ZK01537 Z009562		BW 301.B BWC 301.B			
Ball valve with filter (G 1¼)	ZK03206	X	X	X	X	X
Heat meter						
– For nominal flow rate 1.5 m³/h	7452605	201.A06 to A10				
– For nominal flow rate 2.5 m³/h	7454410	201.A13 to A17				
Heating water buffer cylinder:						
– Vitocell 100-E, type SVPA	Z015309	X	X			
– Vitocell 100-W, type SVPA	Z017685				X	X
Safety equipment block	7143779		BW (1-stage) BW+BWS (2-stage)	X		
Service box	7334502		X	X		

Installation accessories (cont.)

Accessories	Part no.	Vitocal				
		200-G BWC 201.A06 to A17	300-G BW, BWS, BWC 301.B06 to B17	300-G BW, BWS 301.A21 to A45 350-G BW, BWS 351.B20 to B42	222-G BWT-M 221.B06 to B10	333-G BWT 331.C06 to C12
Hydraulic connection accessories, see from page 97						
DHW circulation connection set	ZK04652				X	X
Divicon heating circuit distributor, see from page 98						
Note <i>The Divicon heating circuit distributor is not suitable for heating circuits also used for cooling mode.</i>						
Without mixer						
– With high efficiency circulation pump Wilo Yonos PARA 25/6, DN 20 - ¾	7521287	A1/HC1	A1/HC1	A1/HC1	A1/HC1	A1/HC1
– With high efficiency circulation pump Wilo Yonos PARA 25/6, DN 25 - 1	7521288	A1/HC1	A1/HC1	A1/HC1	A1/HC1	A1/HC1
– With high efficiency circulation pump Wilo Yonos PARA Opt. 25/7.5, DN 32 - 1¼	ZK01831	A1/HC1	A1/HC1	A1/HC1	A1/HC1	A1/HC1
With mixer for heating circuit 2 (M2/HC2)						
– With high efficiency circulation pump Wilo Yonos PARA 25/6, DN 20 - ¾	ZK00967		M2/HC2	M2/HC2	M2/HC2	M2/HC2
– With high efficiency circulation pump Wilo Yonos PARA 25/6, DN 25 - 1	ZK00968		M2/HC2	M2/HC2	M2/HC2	M2/HC2
– With high efficiency circulation pump Wilo Yonos PARA Opt. 25/7.5, DN 32 - 1¼	ZK01825		M2/HC2	M2/HC2	M2/HC2	M2/HC2
With mixer for heating circuit 2 (M2/HC2) or heating circuit 3 (M3/HC3)						
– With high efficiency circulation pump Wilo Yonos PARA 25/6, DN 20 - ¾	7521285	M2/HC2	M3/HC3	M3/HC3	M3/HC3	M3/HC3
– With high efficiency circulation pump Wilo Yonos PARA 25/6, DN 25 - 1	7521286	M2/HC2	M3/HC3	M3/HC3	M3/HC3	M3/HC3
– With high efficiency circulation pump Wilo Yonos PARA Opt. 25/7.5, DN 32 - 1¼	ZK01830	M2/HC2	M3/HC3	M3/HC3	M3/HC3	M3/HC3
Mixer extension kits: See control unit accessories page 181						
Bypass valve	7464889	X	X	X	X	X
Wall mounting bracket for individual Divicon	7465894	X	X	X	X	X
Manifold for 2 Divicons						
– DN 20 - ¾ and DN 25 - 1	7460638	X	X	X	X	X
– DN 32 - 1¼	7466337	X	X	X	X	X
Manifold for 3 Divicons						
– DN 20 - ¾ and DN 25 - 1	7460643		X	X	X	X
– DN 32 - 1¼	7466340		X	X	X	X
Wall mounting bracket for manifold	7465439	X	X	X	X	X
DHW heating with DHW cylinder, see from page 103						
Vitocell 100-V, type CVWA:						
– 300 l	Z016795	201.A06 to A10	301.B06 to B10			
– 390 l	Z016796	X	X			
– 500 l	Z016797	X	X			
Immersion heater EHE:						
– For cylinder capacity 300 l, 390 l, 500 l, installation in upper section	Z012684	X	X			
– For a cylinder capacity of 300 l, installation in lower section	Z016798	X	X			
– For cylinder capacity 390 l, 500 l, installation in lower section	Z016799	X	X			
Solar heat exchanger set for cylinder capacity 390 l, 500 l	7186663	X	X			
Impressed current anode:						
– For cylinder capacity 300 l	7265008	X	X			
– For cylinder capacity 390 l, 500 l	Z004247	X	X			
Safety assembly	7180662	X	X			

Installation accessories (cont.)

Accessories	Part no.	Vitocal 200-G BWC 201.A06 to A17	300-G BW, BWS, BWC 301.B06 to B17	300-G BW, BWS 301.A21 to A45 350-G BW, BWS 351.B20 to B42	222-G BWT-M 221.B06 to B10	333-G BWT 331.C06 to C12
DHW heating with cylinder loading system, see from page 110						
Vitocell 100-V, type CVAA	Z013672		BW (1-stage) BW+BWS (2-stage)			
Heating lance for Vitocell 100-V	ZK00038		BW (1-stage) BW+BWS (2-stage)			
Vitocell 100-L, type CVL	Z002074		BW (1-stage) BW+BWS (2-stage)	X		
Heating lance for Vitocell 100-L	ZK00037		BW (1-stage) BW+BWS (2-stage)	X		
Circulation pump for cylinder loading: – Grundfos UPS 25-60 B	7820403		BW (1-stage) BW+BWS (2-stage)	X		
– Grundfos UPS 32-80 B	7820404		BW (1-stage) BW+BWS (2-stage)	X		
2-way motorised ball valve	7180573		X	X		
DHW heating with freshwater module/heating water storage, see from page 120						
Vitocell 120-E, type SVW, 600 l: – With Vitotrans 353, type PZSA (draw-off rate up to 25 l/min)	Z015393	X	X			
– With Vitotrans 353, type PZMA (draw-off rate up to 48 l/min)	Z015394	X	X			
Vitocell 120-E, type SVW, 950 l: – With Vitotrans 353, type PBSA (draw-off rate up to 25 l/min)	Z017686			X		
– With Vitotrans 353, type PBMA (draw-off rate up to 48 l/min)	Z017687			X		
– With Vitotrans 353, type PBLA (draw-off rate up to 68 l/min)	Z017688			X		
Note <i>Accessories for Vitotrans 353: See separate datasheet.</i>						
Immersion heater EHE: – Heating output 2, 4 or 6 kW	Z014468	X	X			
– Heating output 4, 8 or 12 kW	Z014469	X	X			
3-way diverter valve: – Connection G 1	ZK01343	X	X			
– Connection G 1½	ZK01344	X	X	X		
– Connection G 2	ZK01353	X	X	X		
DHW heating with integral DHW cylinder, see from page 125						
Safety assembly	7180662				X	X
Impressed current anode	7182008				X	X
Installation accessories, see from page 126						
Platform for unfinished floors	7417925				X	X
Drain outlet kit	7176014				X	X
Transport aid, refrigerant circuit module	ZK04568				X	X

Installation accessories (cont.)

Accessories	Part no.	Vitocal				
		200-G BWC 201.A06 to A17	300-G BW, BWS, BWC 301.B06 to B17	300-G BW, BWS 301.A21 to A45 350-G BW, BWS 351.B20 to B42	222-G BWT-M 221.B06 to B10	333-G BWT 331.C06 to C12
Cooling, see from page 127						
NC-Box with mixer	ZK01836	X	BW, BWC (1-stage)		X	X
Hydraulic connection set NC-Box	ZK01958	X	BWC (1-stage)			
AC-Box	ZK01834		BW, BWC (1-stage)			
Connection accessories, AC-Box	7452606		BWC (1-stage)			
Contact humidistat 24 V	7181418		X	X		
Natural cooling extension kit	7179172		X	X		
Frost stat	7179164		X	X		
Connection set for AC-Box	7180574		BW, BWC (1-stage)			
2-way motorised ball valve	7180573		X	X		
3-way diverter valve (R 1¼)	7165482		X	X		
Temperature sensors:						
– Contact temperature sensor (NTC 10 kΩ)	7426463	X	X	X	X	X
– Room temperature sensor (NTC 10 kΩ)	7438537	X	X	X	X	X
Solar, see from page 131						
Solar heat exchanger set (Divicon)	ZK04099				X	X
Solar-Divicon, type PS10 with solar control module, type SM1A	Z017690				X	X
High limit safety cut-out for solar thermal system	7506168				X	X
Collector temperature sensor (NTC 20 kΩ)	7831913				X	X
Heat transfer medium "Tyfocor LS" 25 l	7159727				X	X

8.2 Ventilation unit

Vitovent ventilation units

Vitovent ventilation units

Vitovent mechanical ventilation systems with central ventilation unit can be fully controlled via the heat pump control unit. The heat pump control unit has the entire range of functions required for operation, control parameter configuration and diagnostics of the connected ventilation unit.

Note

For detailed information on designing a mechanical ventilation system with a central ventilation unit: See technical guide "Central mechanical ventilation systems with heat recovery".

Vitovent	Type	Part no.	Countercurrent heat exchanger	Enthalpy heat exchanger	Max. air flow rate in m ³ /h	Max. residential unit area in m ²
200-C	H11S A200	Z014599 (L) Z015391 (R)	X		200	120
	H11E A200	Z014584 (L) Z015392 (R)		X	200	120
300-W	H32S B300	Z014589	X		300	230
	H32E B300	Z014582		X	300	230
	H32S B400	Z014590	X		400	370
	H32E B400	Z014583		X	400	370
300-C	H32S B150	Z014591	X		150	90
300-F	H32S B280	Z011432 (w) Z012121 (s)	X		280	180
	H32E C280	Z014585 (w) Z014586 (s)		X	280	180

(L) Supply air connection, left
(R) Supply air connection, right

(w) Colour: White
(s) Colour: Vitosilver

8.3 Brine circuit (primary circuit)

Sensor well set, primary circuit

Part no. 7460714

For on-site primary circuit pipework.

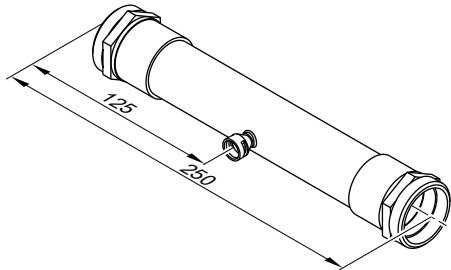

Components:

- Pipe with connection R1¼ (2 pce)
- Sensor well for temperature sensors (flow and return)

Note

The temperature sensors are included in the standard delivery of the heat pump.

Brine accessory pack

Part no.: ZK02447

- Connection set for connecting the heat pump to the primary circuit
- Suitable for Viessmann heat transfer medium "Tyfocor" based on ethylene glycol (see chapter "Heat transfer medium")

Components:

- Air separator with air vent valve
- Safety valve 3 bar (0.3 MPa)
- Pressure gauge
- Drain & fill valve
- 2 shut-off devices male/fem. 2 x 1½

- Wall mounting brackets
- Thermal insulation (vapour diffusion-proof)

Two-stage heat pumps:

- Stages 1 and 2 with the same rated heating output:
One common brine accessory pack
- Stages 1 and 2 with different rated heating outputs:
One brine accessory pack for each stage 1 and 2

Max. flow rate in the primary circuit:

The maximum flow rate in the primary circuit should not exceed 6500 l/h; see pressure drop diagram.

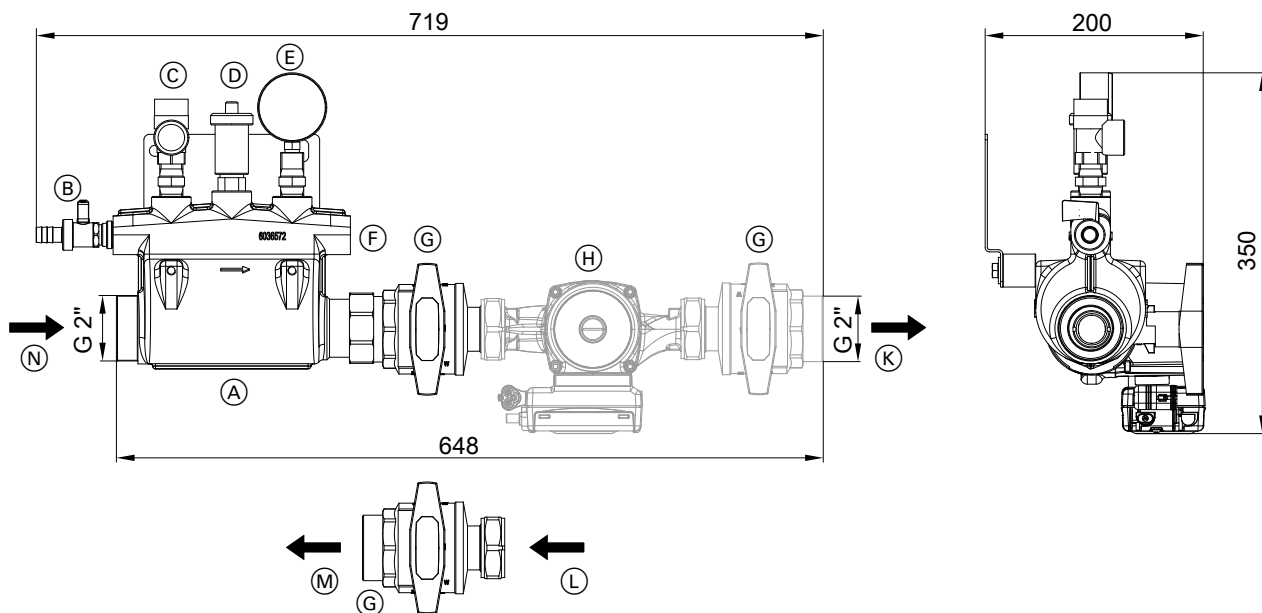

Diagram without thermal insulation

- | | |
|--|--|
| <ul style="list-style-type: none"> (A) Air separator (B) Drain & fill valve (C) Safety valve (3 bar) (D) Air vent valve (E) Pressure gauge (optional connection for pressure switch) (F) Expansion vessel connection | <ul style="list-style-type: none"> (G) Ball valve (H) Primary pump (K) Primary circuit flow (heat pump brine inlet) (L) Primary circuit return (heat pump brine outlet) (M) Primary circuit return (brine outlet, brine accessory pack) (N) Primary circuit flow (brine inlet, brine accessory pack) |
|--|--|

Installation accessories (cont.)

Note

Ⓒ and Ⓓ are components of the pump set for the brine accessory pack.

Installation information

- Fit the brine accessory pack horizontally to ensure the correct function of the air separator.
- The base body can be turned horizontally through 180° to adjust the flow direction.
- The safety components are included with the connection set and can be fitted on site depending on the installation direction of the base body.

- A pressure switch (part no.: 9532663) can be fitted instead of the pressure gauge.
- Check the circulation pump for an adequate residual head (see curves).

Note

All components are thermally insulated with vapour diffusion-proof material.

Pressure drop graph

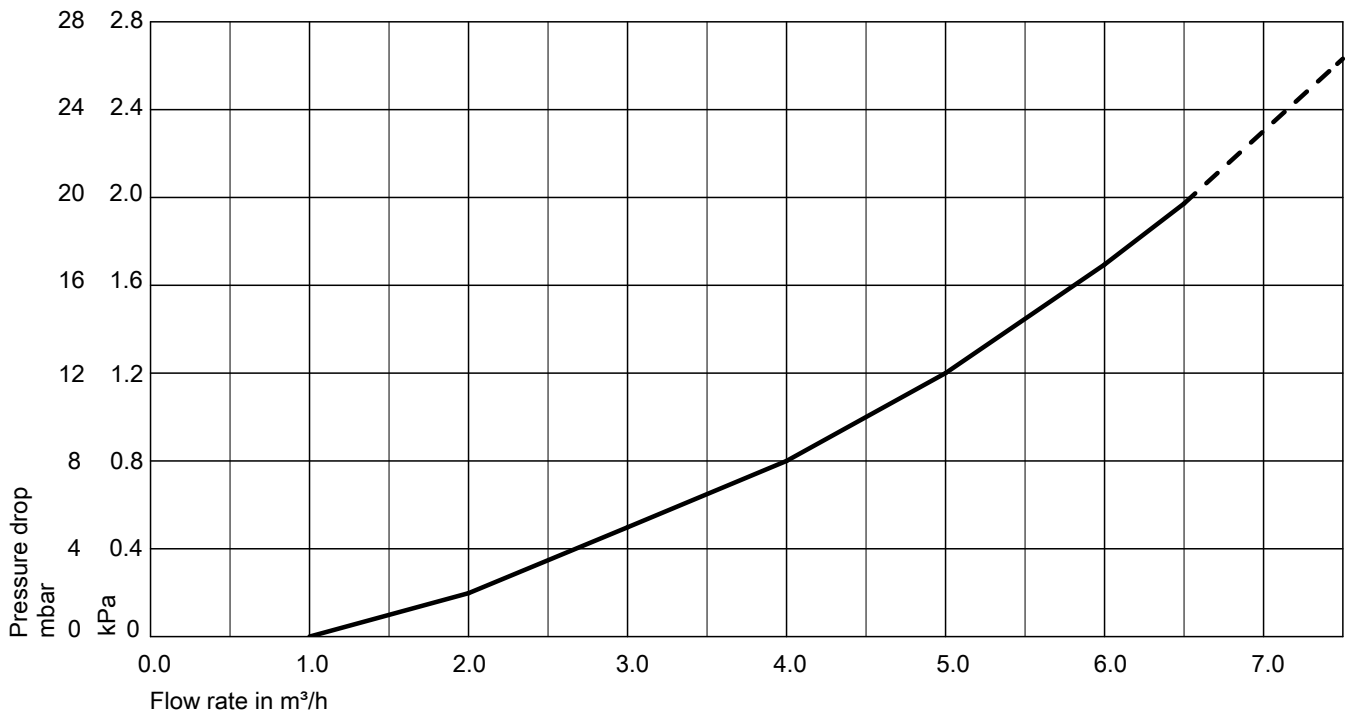

Pump set for brine accessory pack

Part no.: ZK02448, ZK02449

Required if the primary pump is not integrated into the heat pump.

Components:

- Grundfos high efficiency circulation pump UPM/UPMXL GEO, 230 V (see following table)
- Connection G 1½

- Shut-off device male/fem. 2 x 1½
- Thermal insulation for the circulation pump and shut-off device (vapour diffusion-proof)
- Energy efficiency index EEI:
UPM GEO 25/85: ≤ 0.23
UPMXL GEO 25/125: ≤ 0.23

Vitocal Type	300-G BW, BWS 301.B	300-G BW 301.A	350-G BW 351.B
Pump set for brine accessory pack With Grundfos high efficiency circulation pump ZK02448 – UPM GEO 25/85	BW 301.B06 to B17 (1-stage) BW+BWS 301.B06 to B10 (2-stage)	BW 301.A21 (1-stage)	—
ZK02449 – UPMXL GEO 25/125	BW+BWS 301.B13, B17 (2-stage)	BW 301.A29 (1-stage)	BW 351.B20 (1-stage)

The table is intended as a design aid only. When designing, observe the pressure drops in the primary circuit and the pump set delivery heads, see pages 89 and 90.

5822541

Installation accessories (cont.)

Note

Two-stage heat pumps:

- Stages 1 and 2 with the same rated heating output:
One common pump set for brine accessory pack
- Stages 1 and 2 with different rated heating outputs:
 - Stage 1:
With pump set for brine accessory pack
 - Stage 2:
Use an on-site circulation pump without PWM signal, as only 1 PWM pump can be connected to the heat pump control unit on the primary side.

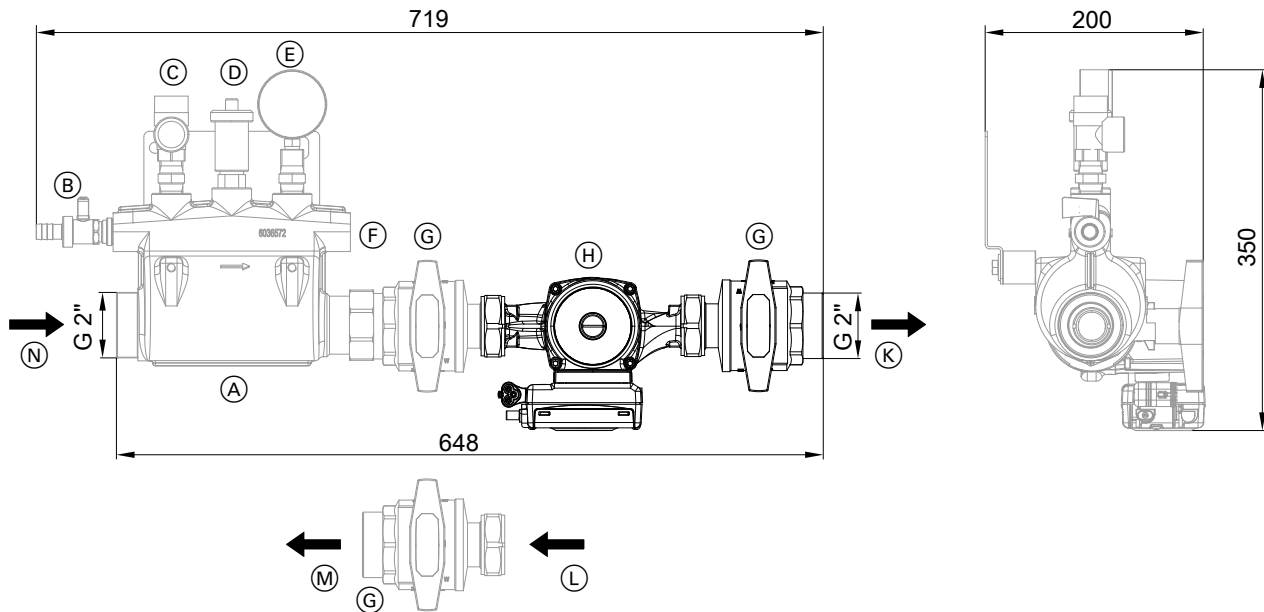

Diagram without thermal insulation

- | | |
|--|---|
| (A) Air separator | (G) Ball valve |
| (B) Drain & fill valve | (H) Primary pump |
| (C) Safety valve (3 bar) | (K) Primary circuit flow (heat pump brine inlet) |
| (D) Air vent valve | (L) Primary circuit return (heat pump brine outlet) |
| (E) Pressure gauge (optional connection for pressure switch) | (M) Primary circuit return (brine outlet, brine accessory pack) |
| (F) Expansion vessel connection | (N) Primary circuit flow (brine inlet, brine accessory pack) |

Note

(A) to (G) are components of the brine accessory pack.

Installation accessories (cont.)

Curve for type UPM GEO 25/85

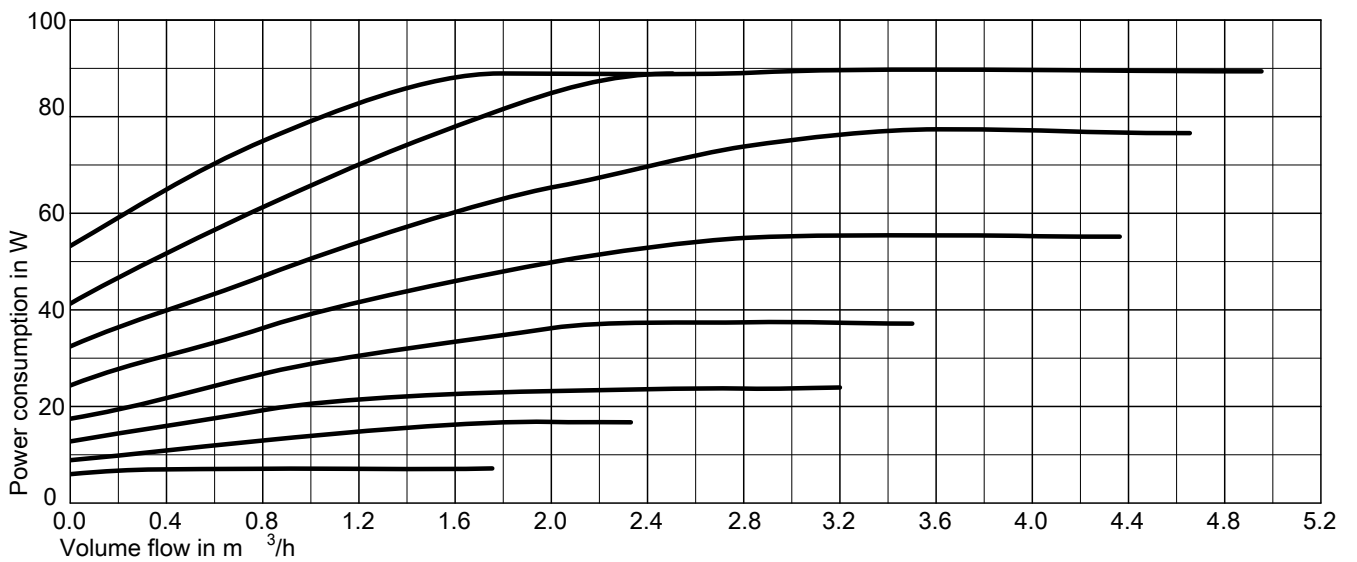
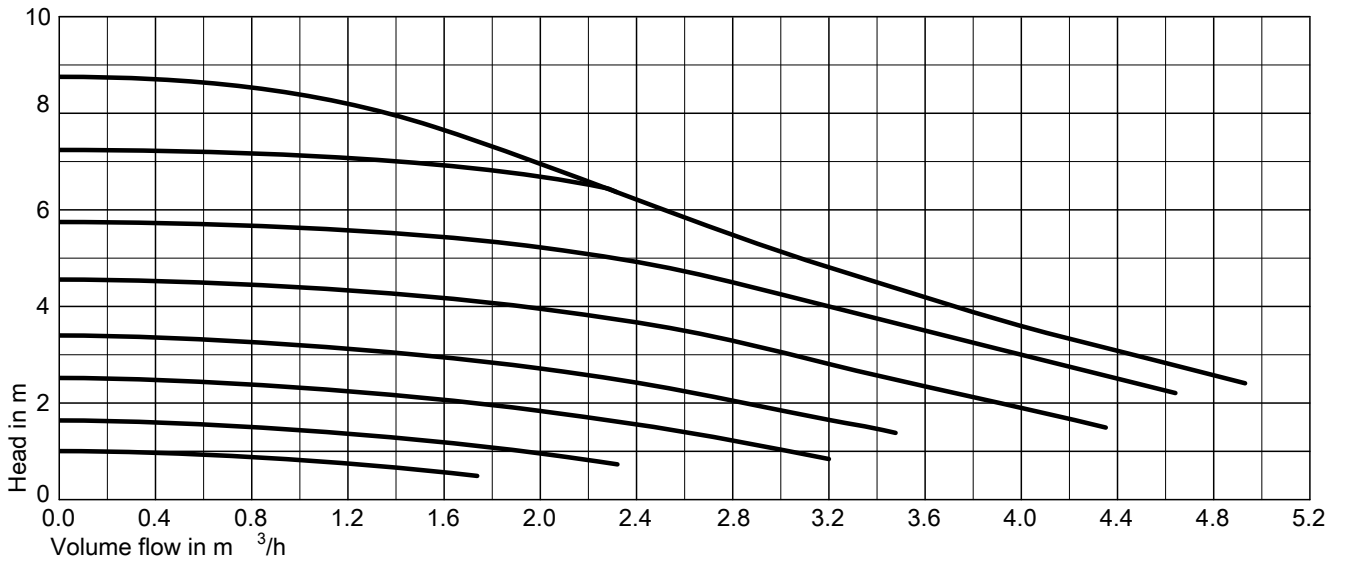

Installation accessories (cont.)

Curve for type UPMXL GEO 25/125

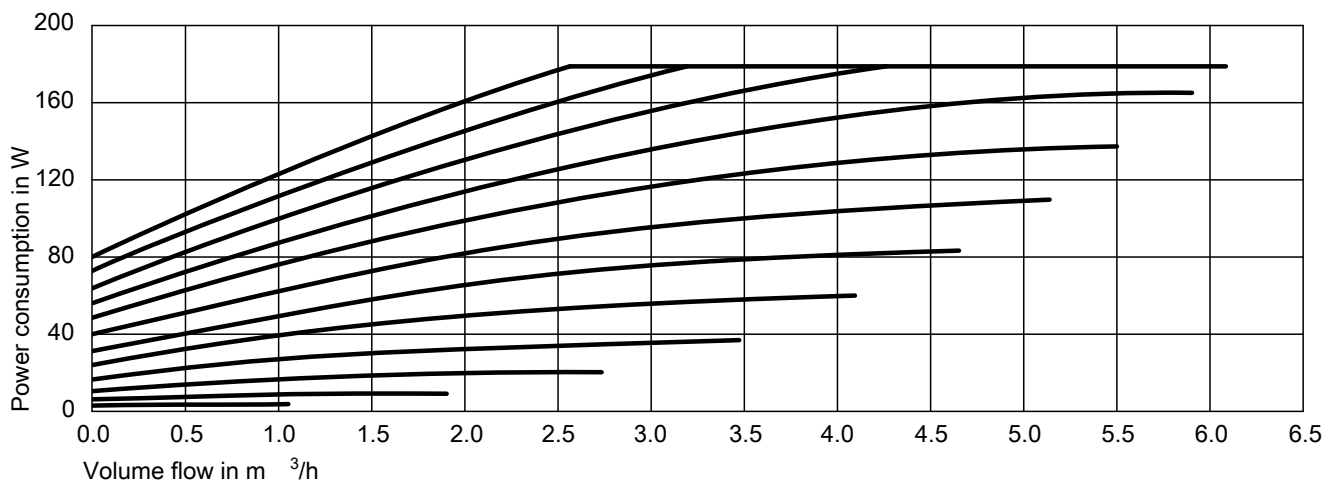
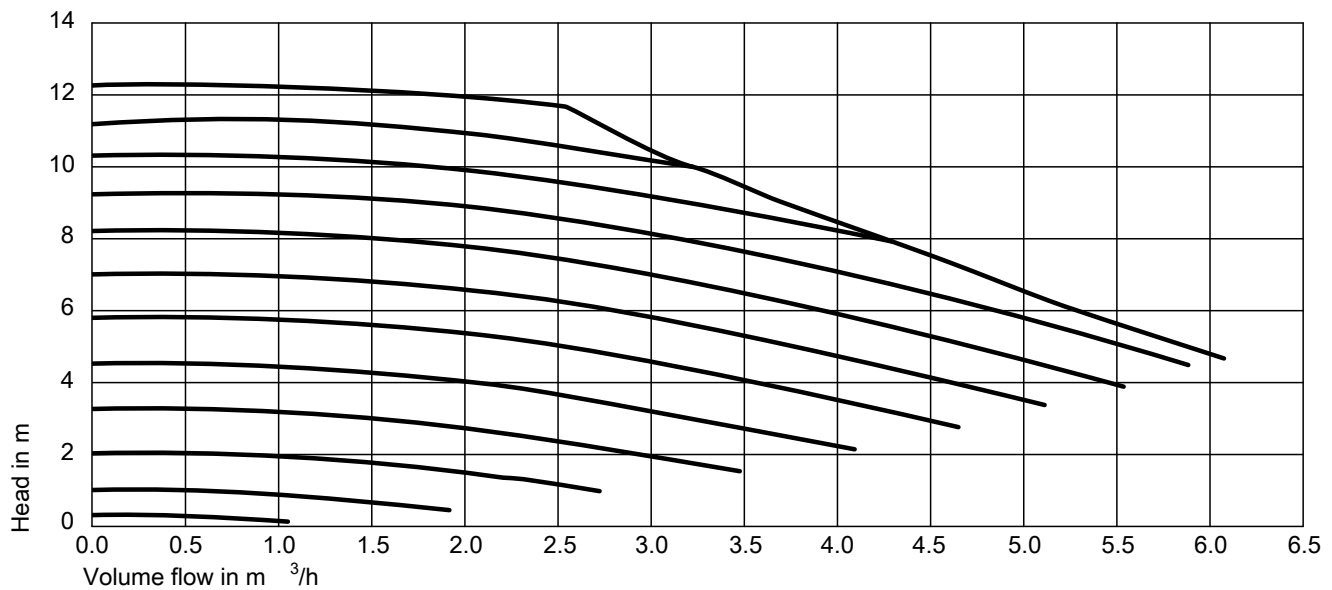

Brine expansion vessel

Part no.: 7248242, 7248243, 7248244, 7248245

With shut-off valve and fixings

Installation accessories (cont.)

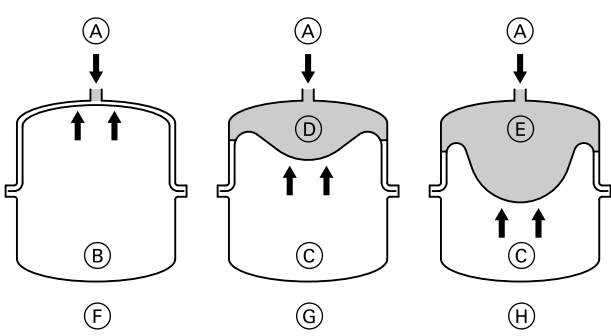

- (A) Heat transfer medium
- (B) Nitrogen charge
- (C) Nitrogen buffer
- (D) Minimum safety seal 3 l
- (E) Safety seal
- (F) Delivered condition (pre-charge pressure 4.5 bar, 0.45 MPa)
- (G) Primary circuit filled, without heat effect
- (H) At maximum pressure and the highest heat transfer medium temperature

The brine expansion vessel is a sealed vessel where the gas space (nitrogen charge) is separated from the space containing liquid (heat transfer medium) by a diaphragm and the pre-charge pressure is subject to the system height.

Specification

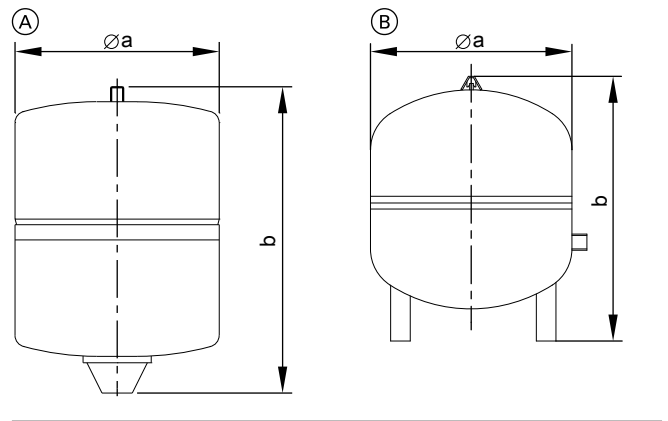

Expansion vessel	Part no.	Capacity l	Pre-charge pressure bar/Pa	Ø a mm	b mm	Connection	Weight kg
(A)	7248242	25	4.5/0.45	280	490	R ¾	9.1
	7248243	40	4.5/0.45	354	520	R ¾	9.9
(B)	7248244	50	4.5/0.45	409	505	R 1	12.3
	7248245	80	4.5/0.45	480	566	R 1	18.4

Note

To size the brine expansion vessel for geothermal probes, see the engineering information on page 151.

Pressure switch (primary circuit)

Part no. 9532663

Switches off the primary pump in the event of a pressure drop in the primary circuit.

Note

- Cannot be used in conjunction with potassium carbonate-based heat transfer medium.
- Observe the statutory requirements when using a pressure switch in the primary circuit.

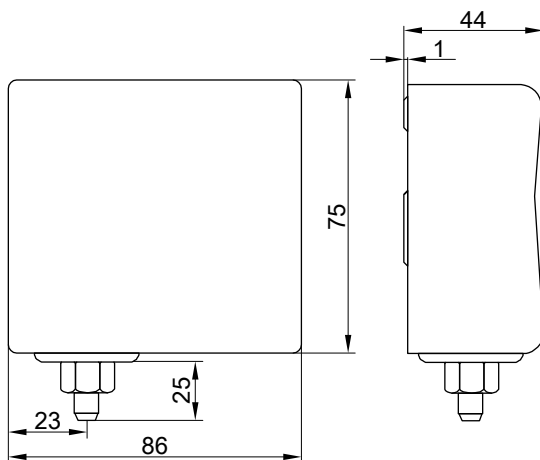

Brine manifold for geothermal probes/geothermal collectors

Locking ring fittings	Number of brine circuits	Part no.
PE 25 x 2.3	2	ZK01285
	3	ZK01286
	4	ZK01287
PE 32 x 2.9	2	ZK01288
	3	ZK01289
	4	ZK01290

Brine manifold for geothermal probes/geothermal collectors
 Plastic brine manifold. Can be fitted to the house wall, in the cellar duct or in the central service duct.

- 2 drain & fill valves
- Installation accessories

Components:

- Flow and return connectors G 1½
- Locking ring fittings with plug-in connection onto the brine manifold
- Each brine circuit can be shut off individually

Up to 10 brine circuits can be connected in series to a single flow or return; up to 20 brine circuits can be connected in a parallel circuit. Brine manifolds for 2, 3 and 4 brine circuits can be combined in any order.

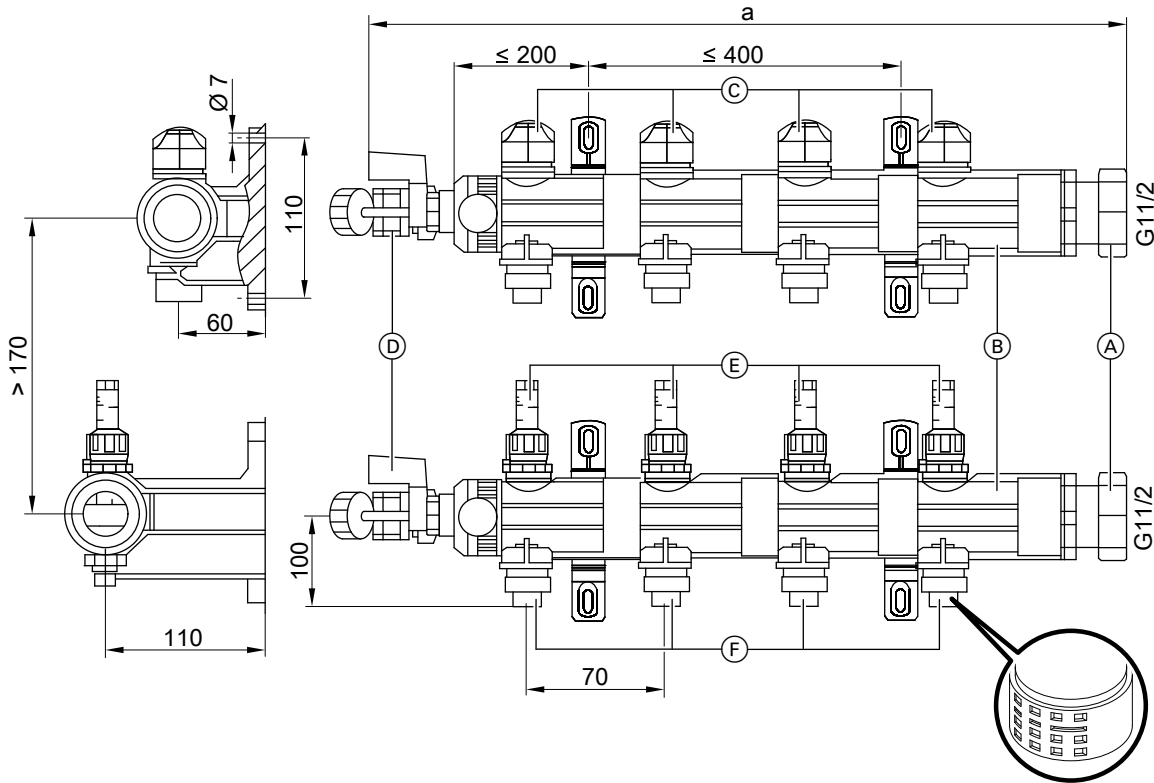

- (A) G 1½ union nut for connecting a ball valve or an additional module
- (B) G 1½ header
- (C) Brine circuit shut-off damper
- (D) Drain & fill valves
- (E) Flow limiter with integral brine circuit shut-off valve
- (F) Locking ring fittings for PE 32 x 2.9 mm or PE 25 x 2.3 mm with plug-in connection onto the brine manifold

Brine manifold length

Number of brine circuits	2	3	4	5	6	7	8	9	10
Dimension a in mm	270	340	410	480	550	620	690	760	830

Installation accessories (cont.)

Brine manifold pressure drop

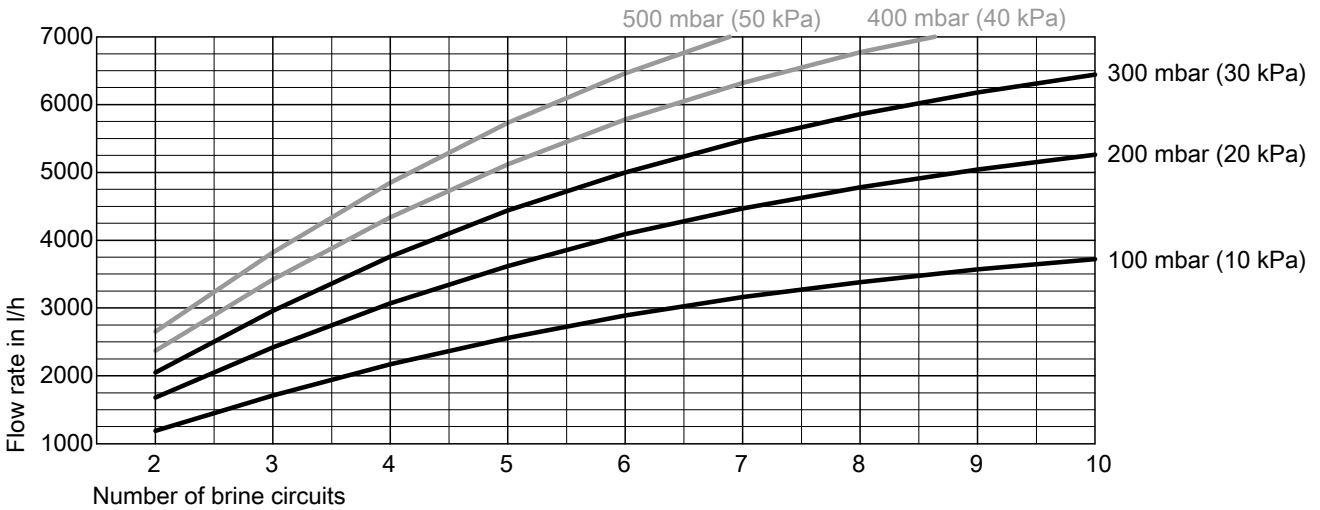

Pressure drop:

- Observe the primary pump residual head.
- Recommendation:
Maximum brine manifold pressure drop: 300 mbar

Connection versions

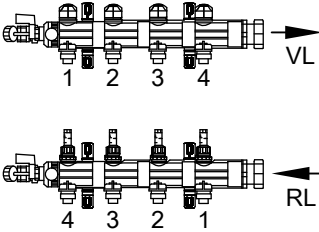

Example for 4 brine circuits in series

RL Brine return
VL Brine flow

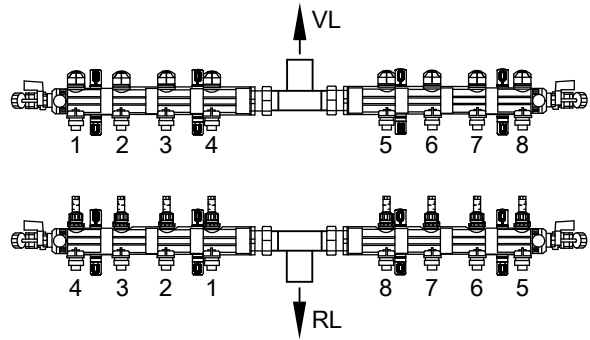

Example for 8 brine circuits in parallel

RL Brine return
VL Brine flow

Heat transfer medium "Tyfocor"

- 30 l in a disposable container
Part no. 9532655
- 200 l in a disposable container
Part no. 9542602

Light green ready mixed medium for the primary circuit, down to -16°C , based on ethylene glycol with corrosion inhibitors

Filling station

Part no. 7188625
For filling the primary circuit

Components:

- Self-priming impeller pump (30 l/min)
- Dirt filter, inlet side

- Hose, inlet side (0.5 m)
- Connection hose (2 pce, each 2.5 m)
- Packing crate (can be used as flushing tank)

8.4 Heating circuit (secondary circuit)

Instantaneous heating water heater

- Type BW 301.B
Part no. **ZK01538**
- Type BWC 301.B
Part no. **ZK01537**
- Type BWC 201.A
Part no. **Z009562**

For installation in the heat pump; can be plugged in electrically and hydraulically. When used in heat pump cascades, install in lead heat pump only.

Note

Instantaneous heating water heaters cannot be installed in type BWS.

Components:

- High limit safety cut-out
- Switching module
- Thermal insulation
- Type BW only: Hydraulic connection set

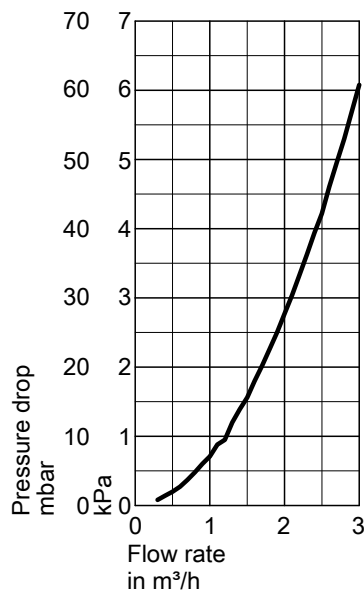
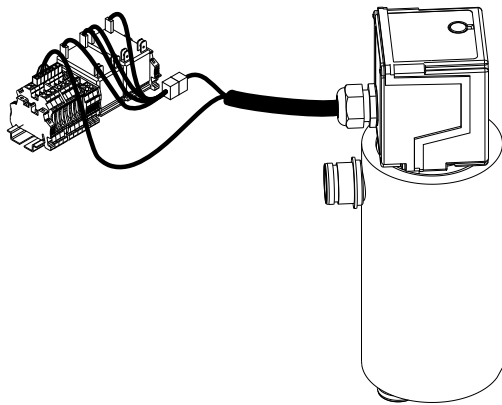

Pressure drop

Specification

Rated voltage	3/N/PE 400 V/50 Hz or 1/N/PE 230 V/50 Hz
Max. switching current	4(2) A
Rated output	Three-stage 3/6/9 kW
Fuse rating	3 x B16A, 1-pole

Ball valve with filter (G 1¼)

Part no. **ZK03206**

- Ball valve with integral stainless steel water filter
- For installation in the heating water return and protection of the condenser against contamination

Heat meter

For installation in the heat pump.

Part no.	Nominal flow rate in m³/h
7452605	1.5
7454410	2.5

Components:

- Flow meter with threaded connector for capturing the flow rate.
- Temperature sensor Pt1000, connected to the heat meter, sensor lead 1.5 m long.

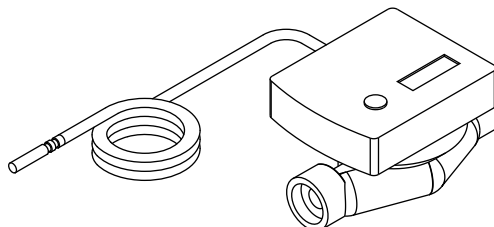

Pressure drop graph

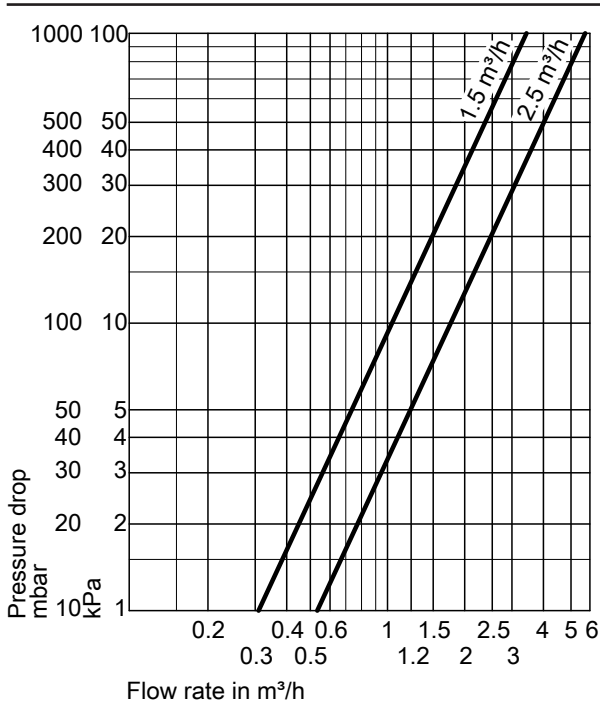

Specification

		Heat meter with nominal flow rate	
		1.5 m³/h	2.5 m³/h
Lead length	m	1.5	
IP rating		IP 54 to EN 60529; ensure through design/installation.	
Permissible ambient temperature			
– Operation	°C	5 to 55	
– Storage and transport	°C	–20 to +70	
Sensor type		Pt1000	Pt1000
Max. operating pressure	bar	10	10
Nominal diameter	DN	15	20
Connection thread at the fitting	G	¾	1
Fitted length		110	130
Max. flow rate	l/h	3000	5000
Minimum flow rate			
– Horizontal installation	l/h	30	50
– Vertical installation	l/h	60	100
Start-up value (for horizontal installation)	l/h	10	16
Max. measurable heating output	kW	313	523
Battery life		Approx. 10 years	

Heating water buffer cylinder

- Vitocell 100-E, type SVPA
Part no.: Z015309
Vitosilver
- Vitocell 100-W, type SVPA
Part no.: Z017685
Vitopearlwhite

Wall mounted heating water buffer cylinder for installation in the secondary circuit return

- For storing heating water in conjunction with heat pumps with up to 17 kW heating output
- For ensuring the minimum system volume

Standard delivery:

- Heating water buffer cylinder with EPS thermal insulation and sheet steel casing
- Wall mounting bracket
- Overflow valve DN 25, R 1

Specification

Cylinder capacity (AT: Actual water capacity)	l	46
Max. flow temperature	°C	95
Max. operating pressure	bar	3
	MPa	0.3
Weight	kg	18
Connections (male thread)		
Heating water flow and return	G	1½
Standby heat loss	kWh/24 h	0.94
Energy efficiency class		B

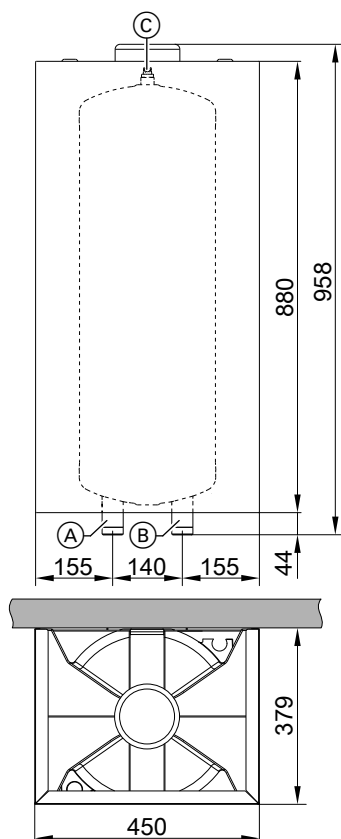

- (A) Heating water flow or heating water return R 1, as required
- (B) Heating water return or heating water flow R 1, as required
- (C) Air vent valve

Safety equipment block

Part no. 7143779

Components:

- Safety valve R ½ (discharge pressure 3 bar)
- Pressure gauge
- Automatic air vent valve with automatic shut-off facility
- Thermal insulation

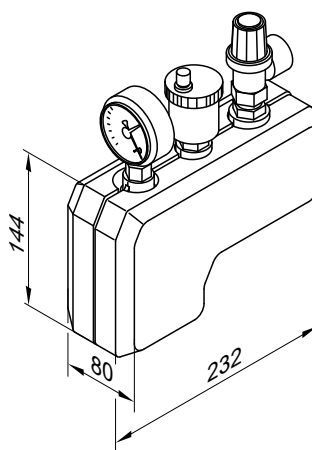

8.5 Hydraulic connection accessories

DHW circulation connection set

Part no. ZK04652

Components:

- DHW circulation pump
- Pipe assembly with thermal insulation
- For installation in the heat pump casing

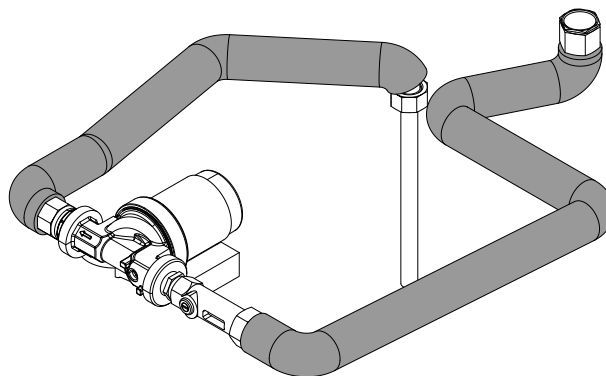

8.6 Divicon heating circuit distributor

Note

The Divicon heating circuit distributor is not suitable for heating circuits that are also used for cooling operation.

Design and function

- Available with R 3/4, R 1 and R 1 1/4 connections
- With heating circuit pump, check valve, ball valves with integral thermometers and 3-way mixer or without mixer
- Quick and simple installation due to pre-assembled unit and compact design
- All-round thermal insulation shells for low radiation losses
- High efficiency circulation pumps and optimised mixer curve ensure low electricity costs and precise control characteristics
- The bypass valve for hydronic balancing of the heating system is available as an accessory and is provided as a threaded component for inserting into the prepared hole in the cast body.

- Individually wall mounted or with a double manifold
 - Also available as a set; see Viessmann pricelist for more details.
- For part numbers in conjunction with the different circulation pumps, see the Viessmann pricelist.**

The dimensions of the heating circuit distributor are the same, with or without mixer.

Divicon with mixer

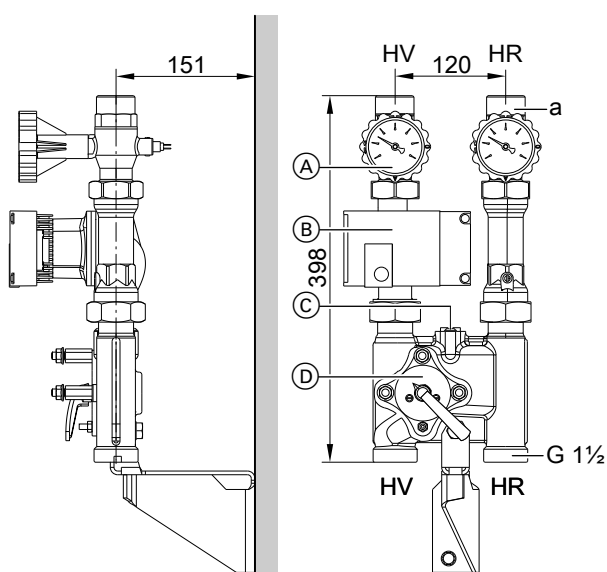

Wall mounting, shown without thermal insulation and without mixer drive extension kit

- HR Heating return
- HV Heating flow
- (A) Ball valves with thermometer (as programming unit)
- (B) Circulation pump
- (C) Bypass valve (accessories)
- (D) Mixer-3

Divicon without mixer

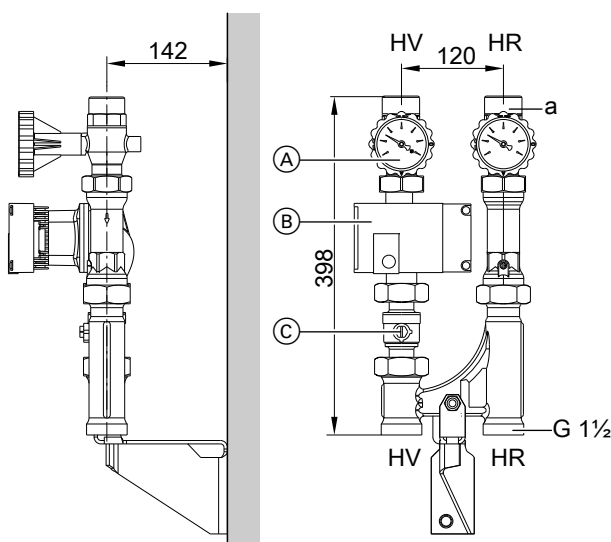

Wall mounted, diagram without thermal insulation

- HR Heating return
- HV Heating flow
- (A) Ball valves with thermometer (as programming unit)
- (B) Circulation pump
- (C) Ball valve

Heating circuit connection	R	3/4	1	1 1/4
Max. flow rate	m ³ /h	1.0	1.5	2.5
a (female)	Rp	3/4	1	1 1/4
a (male)	G	1 1/4	1 1/4	2

Determining the required nominal diameter

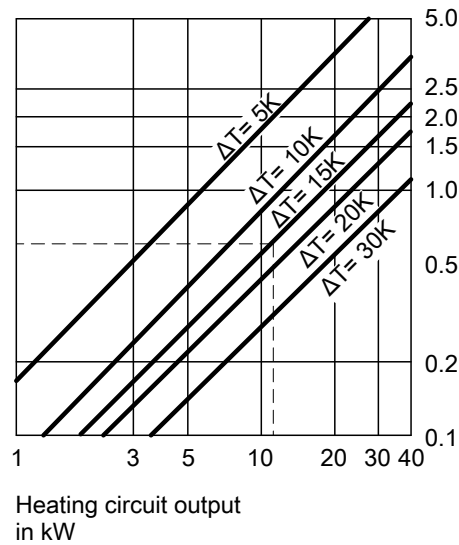
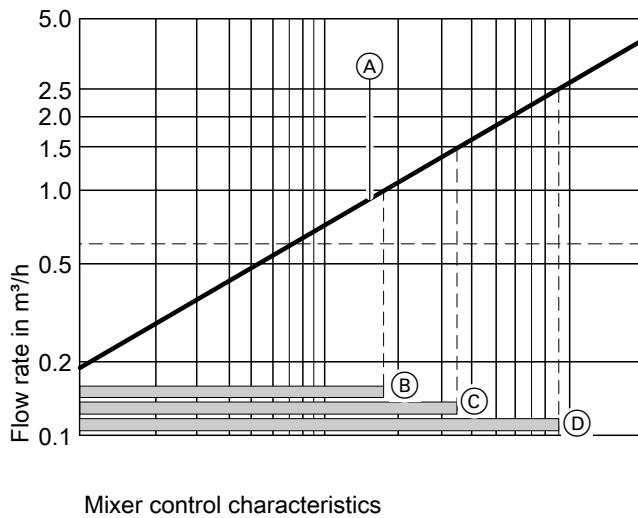

- Ⓐ Divicon with mixer-3
The operating ranges marked Ⓑ to Ⓓ provide optimum control characteristics with the Divicon mixer:
- Ⓑ Divicon with mixer-3 (R ¾)
Operating range: 0 to 1.0 m³/h

- Ⓒ Divicon with mixer-3 (R 1)
Operating range: 0 to 1.5 m³/h
- Ⓓ Divicon with mixer-3 (R 1¼)
Operating range: 0 to 2.5 m³/h

Example:

- Heating circuit for radiators with a heating output of $\dot{Q} = 11.6 \text{ kW}$
- Heating system temperature 75/60 °C ($\Delta T = 15 \text{ K}$)

$$\dot{Q} = \dot{m} \cdot c \cdot \Delta T \quad c = 1.163 \frac{\text{Wh}}{\text{kg} \cdot \text{K}} \quad \dot{m} \hat{=} \dot{V} \quad (1 \text{ kg} \approx 1 \text{ dm}^3)$$

$$\dot{V} = \frac{\dot{Q}}{c \cdot \Delta T} = \frac{11600 \text{ W} \cdot \text{kg} \cdot \text{K}}{1.163 \text{ Wh} \cdot (75-60) \text{ K}} = 665 \frac{\text{kg}}{\text{h}} \hat{=} 0.665 \frac{\text{m}^3}{\text{h}}$$

c Specific thermal capacity

\dot{m} Mass flow rate

\dot{Q} Heating output

\dot{V} Flow rate

Select the smallest possible mixer within the application limit with the value \dot{V} .

Example result: Divicon with mixer-3 (R ¾)

Circulation pump curves and pressure drop on the heating water side

The residual pump head results from the differential between the selected pump curve and the pressure drop curve of the respective heating circuit distributor or further components (pipe assembly, distributor, etc.).

The following pump graphs show the pressure drop curves of the different Divicon heating circuit distributors.

Maximum flow rate for Divicon:

- With R ¾ = 1.0 m³/h
- With R 1 = 1.5 m³/h
- With R 1¼ = 2.5 m³/h

Example:

Flow rate $\dot{V} = 0.665 \text{ m}^3/\text{h}$

Selected:

- Divicon with mixer R ¾
- Wilo Yonos PARA 25/6 circulation pump, variable differential pressure operating mode and set to maximum delivery head
- Pump rate 0.7 m³/h

Head of the relevant pump

curve: 48 kPa
 Divicon pressure drop: 3.5 kPa
 Residual head: 48 kPa – 3.5 kPa = 44.5 kPa.

Note

For further components (pipe assembly, distributor, etc.) determine the pressure drop and deduct it from the residual head.

Differential pressure-dependent heating circuit pumps

According to the [German] Energy Saving Ordinance (EnEV), circulation pumps in central heating systems must be sized in accordance with current technical rules.

Ecodesign Directive 2009/125/EC requires high efficiency circulation pumps to be used throughout Europe from 1 January 2013, if the pumps are not installed in the heat generator.

Design information

The use of differential pressure-dependent heating circuit pumps requires heating circuits with variable flow rates, e.g. single-line and twin-line heating systems with thermostatic valves and underfloor heating systems with thermostatic valves or zone valves.

Installation accessories (cont.)

Wilo Yonos PARA 25/6

- Particularly power saving, high efficiency circulation pump
- Energy efficiency index $EEI \leq 0.20$

Operating mode: Constant differential pressure

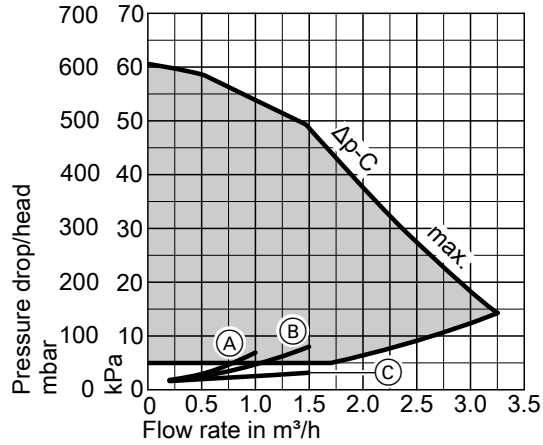

- (A) Divicon R ¾ with mixer
- (B) Divicon R 1 with mixer
- (C) Divicon R ¾ and R 1 without mixer

Operating mode: Variable differential pressure

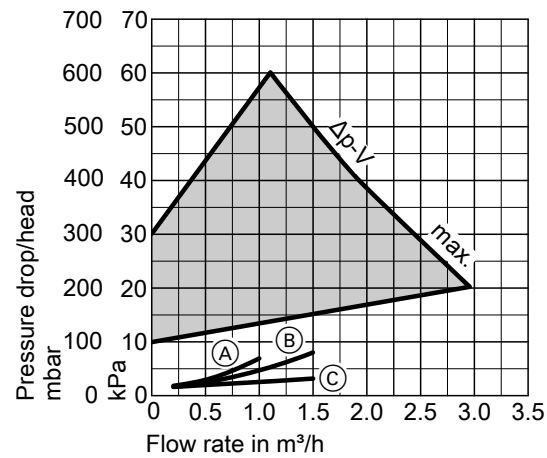

- (A) Divicon R ¾ with mixer
- (B) Divicon R 1 with mixer
- (C) Divicon R ¾ and R 1 without mixer

Bypass valve

Part no. 7464889

- For hydronic balancing of the heating circuit with mixer
- To be inserted into the Divicon.

Wilo Yonos PARA Opt. 25/7.5

- Energy efficiency index $EEI \leq 0.21$

Operating mode: Constant differential pressure

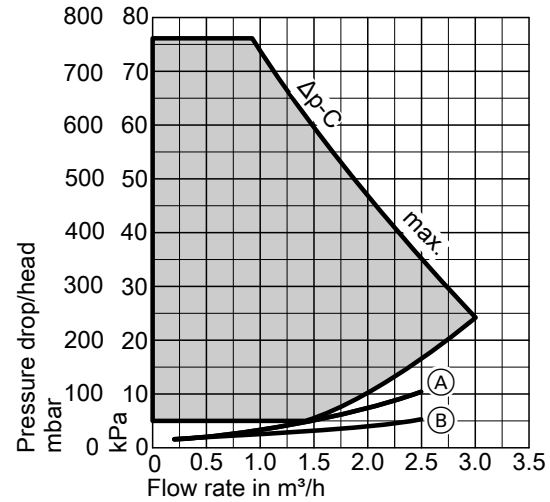

- (A) Divicon R 1¼ with mixer
- (B) Divicon R 1¼ without mixer

Operating mode: Variable differential pressure

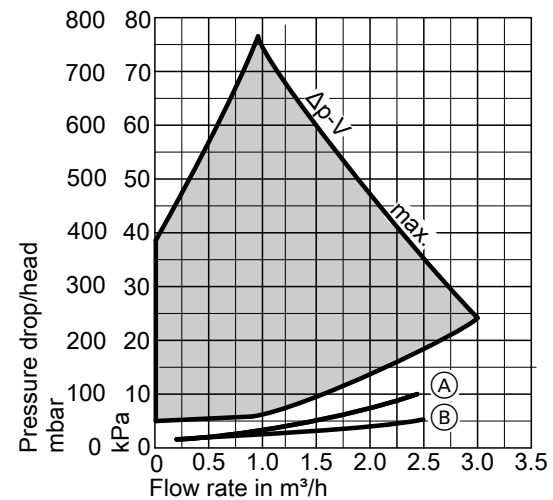

- (A) Divicon R 1¼ with mixer
- (B) Divicon R 1¼ without mixer

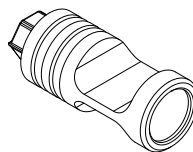

Wall mounting bracket for individual Divicon

Part no. 7465894
With screws and rawl plugs

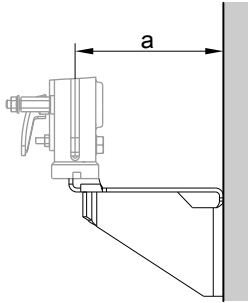

Divicon	With mixer	Without mixer
a mm	151	142

Manifold

- With thermal insulation
- Wall mounted with wall mounting bracket to be ordered separately
- The connection between boiler and manifold must be made on site.

For 2 Divicons

Part no. 7460638
For Divicon R ¾ and R 1

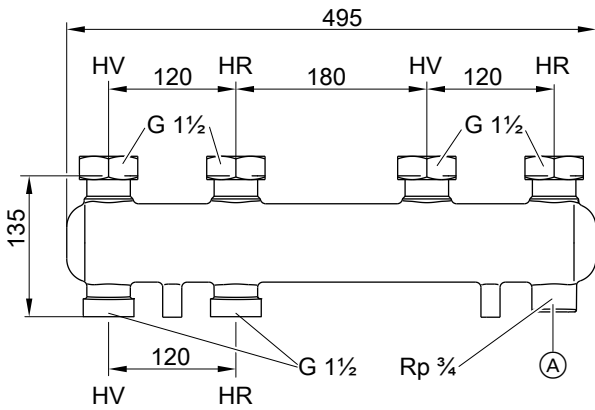

- (A) Connection option for expansion vessel
- HV Heating water flow
- HR Heating water return

Part no. 7466337
For Divicon R 1¼

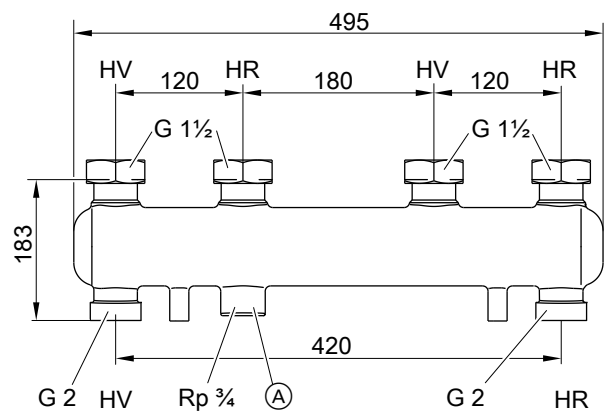

- (A) Connection option for expansion vessel
- HV Heating water flow
- HR Heating water return

Installation accessories (cont.)

Pressure drop

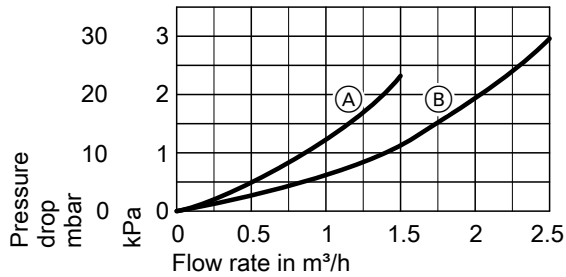

- (A) Manifold for Divicon R ¾ and R 1
- (B) Manifold for Divicon R 1¼

For 3 Divicons

Part no. 7460643

For Divicon R ¾ and R 1

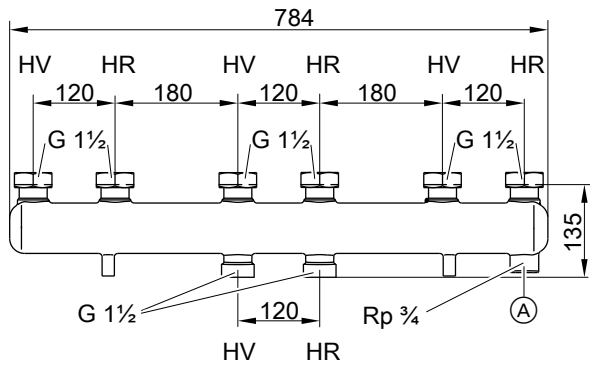

- (A) Connection option for expansion vessel
- HV Heating water flow
- HR Heating water return

Part no. 7466340

For Divicon R 1¼

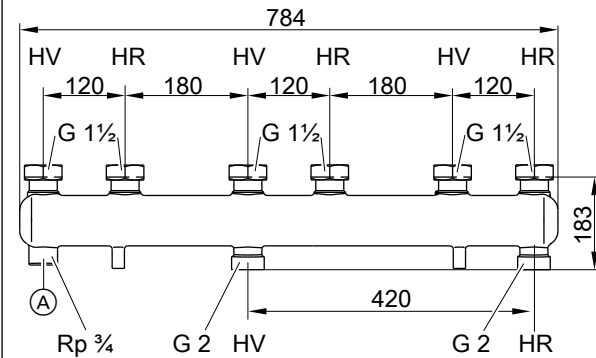

- (A) Connection option for expansion vessel
- HV Heating water flow
- HR Heating water return

Pressure drop

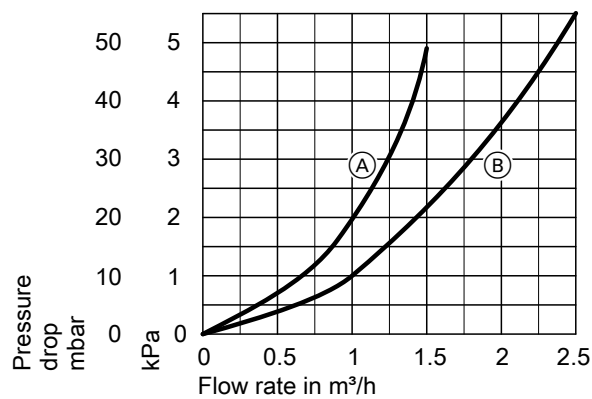

- (A) Manifold for Divicon R ¾ and R 1
- (B) Manifold for Divicon R 1¼

Wall mounting bracket for manifold

Part no. 7465439
With screws and rawl plugs

Divicon	R 3/4 and R 1	R 1 1/4
a mm	142	167

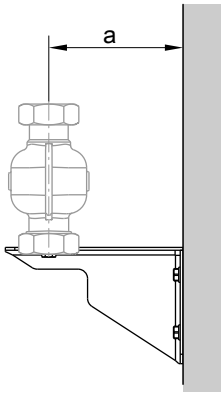

8.7 Accessories for DHW heating with DHW cylinder

Vitocell 100-V, type CVWA

For DHW heating in conjunction with heat pumps up to 17 kW and solar collectors; also suitable for boilers and district heating systems

Suitable for the following systems:

- DHW temperature up to 95 °C
- Heating water flow temperature up to 110 °C

- Solar flow temperature up to 140 °C
- Operating pressure on the heating water side up to 10 bar (1.0 MPa)
- Operating pressure on the solar side up to 10 bar (1.0 MPa)
- Operating pressure on the DHW side up to 10 bar (1.0 MPa)

Specification

Type	CVWA				
Cylinder capacity (AT: Actual water capacity)	l	300	390	500	
Heating water capacity	l	22	27	40	
Gross volume	l	322	417	540	
DIN registration no.	9W173-13MC/E				
Continuous output for DHW heating from 10 to 45 °C and a heating water flow temperature of ... at the heating water flow rate stated below	90 °C	kW	85	98	118
		l/h	2093	2422	2896
	80 °C	kW	71	82	99
		l/h	1749	2027	2428
	70 °C	kW	57	66	79
		l/h	1399	1623	1950
Continuous output for DHW heating from 10 to 60°C and a heating water flow temperature of ... at the heating water flow rate stated below	90 °C	kW	73	85	102
		l/h	1255	1458	1754
	80 °C	kW	58	67	81
	l/h	995	1159	1399	
	70 °C	kW	41	48	59
		l/h	710	830	1008
Heating water flow rate for the stated continuous outputs	m³/h	3.0	3.0	3.0	
Draw-off rate	l/min	15	15	15	
Drawable water volume without reheating					
– Cylinder content heated to 45 °C	l	210	285	350	
Water at t = 45 °C (constant)					
– Cylinder content heated to 55 °C	l	210	285	350	
Water at t = 55 °C (constant)					
Heat-up time if connected to a heat pump with 16 kW rated heating output and a heating water flow temperature of 55 or 65 °C					
– For DHW heating from 10 to 45 °C	min	50	60	66	
– For DHW heating from 10 to 55 °C	min	60	76	85	

5822541

Installation accessories (cont.)

Type		CVWA		
		300	390	500
Cylinder capacity (AT: Actual water capacity)	l			
Max. connectable heat pump output at 65 °C heating water flow and 55 °C DHW temperature and the specified heating water flow rate	kW	12	15	17
Max. aperture area that can be connected to the solar heat exchanger set (accessories)				
– Vitosol-T	m ²	—	6	6
– Vitosol-F	m ²	—	11.5	11.5
Performance factor N_L in conjunction with a heat pump				
Cylinder storage temperature	45 °C	1.7	2.5	3.5
	50 °C	1.9	2.8	3.9
Standby heat loss	kWh/24 h	1.65	1.80	1.90
Dimensions				
Length (∅)				
– With thermal insulation	a mm	667	859	859
– Excl. thermal insulation	mm	—	650	650
Total width				
– With thermal insulation	b mm	744	923	923
– Excl. thermal insulation	mm	—	881	881
Height				
– With thermal insulation	c mm	1734	1624	1948
– Excl. thermal insulation	mm	—	1522	1844
Height when tilted				
– Incl. thermal insulation	mm	1825	—	—
– Excl. thermal insulation	mm	—	1550	1860
Entire weight incl. thermal insulation	kg	180	190	200
Heating surface	m ²	3.0	4.0	5.5
Connections				
Heating water flow and return (male thread)	R	1¼	1¼	1¼
Cold water, DHW (male thread)	R	1	1	1
Solar heat exchanger set (male thread)	R	—	¾	¾
DHW circulation (male thread)	R	¾	¾	¾
Immersion heater (female thread)	Rp	1½	1½	1½
Energy efficiency class		B	B	B

Information regarding continuous output

When designing systems with the specified or calculated continuous output, select a matching circulation pump. The stated continuous output is achieved only if the rated boiler heating output is \geq continuous output.

Note

DHW cylinder with a capacity of 300 litres also available as Vitocell 100-W in white.

Installation accessories (cont.)

300 litre capacity

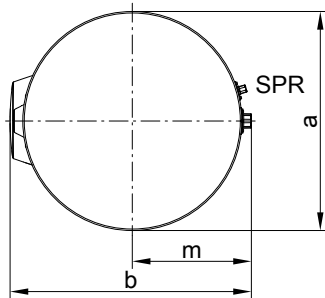
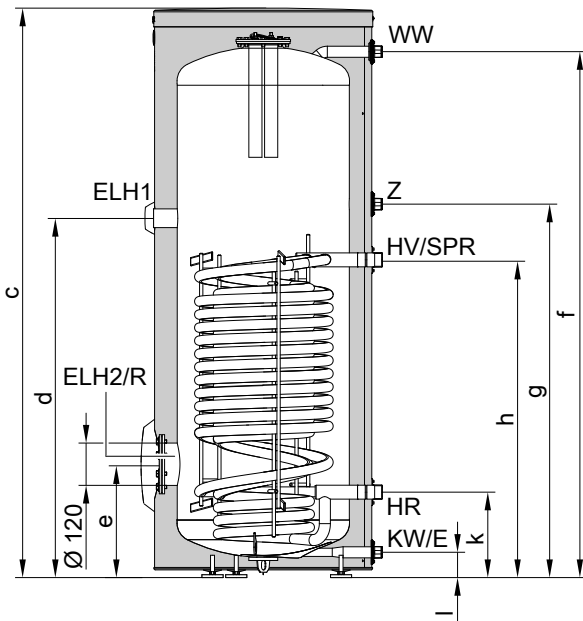

Dimensions

Cylinder capacity		l	300
Length (∅)	a	mm	667
Width	b	mm	744
Height	c	mm	1734
	d	mm	1063
	e	mm	314
	f	mm	1601
	g	mm	1137
	h	mm	967
	k	mm	261
	l	mm	77
	m	mm	360

- E Drain outlet
- ELH1 Connector for immersion heater
- ELH2 Flanged aperture for immersion heater
- HR Heating water return
- HV Heating water flow
- KW Cold water
- R Inspection and cleaning aperture with flange cover
- SPR Sensor well for cylinder temperature sensor or temperature controller (internal diameter 16 mm)
- WW DHW
- Z DHW circulation

Installation accessories (cont.)

390 and 500 l capacity

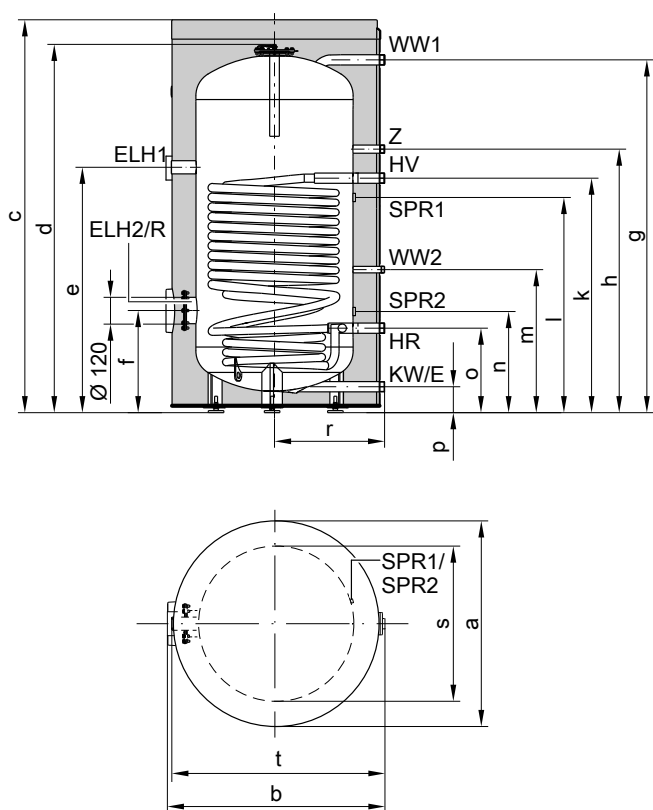

Dimensions

Cylinder capacity	I	390	500	
Length (∅)	a	mm	859	859
Width	b	mm	923	923
Height	c	mm	1624	1948
	d	mm	1522	1844
	e	mm	1000	1307
	f	mm	403	442
	g	mm	1439	1765
	h	mm	1070	1370
	k	mm	950	1250
	l	mm	816	1116
	m	mm	572	572
	n	mm	366	396
	o	mm	330	330
	p	mm	88	88
	r	mm	455	455
	s	mm	650	650
	t	mm	881	881

Performance factor N_L

To DIN 4708

Cylinder storage temperature T_{cyl} = cold water inlet temperature + 50 K +5 K/-0 K

- E Drain outlet
- ELH1 Connector for immersion heater
- ELH2 Flanged aperture for immersion heater
- HR Heating water return
- HV Heating water flow
- KW Cold water
- R Inspection and cleaning aperture with flange cover
- SPR1 Clamping device for securing immersion temperature sensors to the cylinder jacket. Fixing point for 3 immersion temperature sensors per clamping device
- SPR2 Clamping device for securing immersion temperature sensors to the cylinder jacket. Fixing point for 3 immersion temperature sensors per clamping device
- WW1 DHW
- WW2 DHW from solar heat exchanger set
- Z DHW circulation

Cylinder capacity	I	300	390	500
Performance factor N_L				
at heating water flow temperature				
90 °C		9.5	12.6	16.5
80 °C		8.5	11.3	14.9
70 °C		7.5	10.0	13.3

Installation accessories (cont.)

Information on performance factor N_L

The performance factor N_L depends on the cylinder storage temperature T_{cyl} .

Standard values

- $T_{cyl} = 60\text{ °C} \rightarrow 1.0 \times N_L$
- $T_{cyl} = 55\text{ °C} \rightarrow 0.75 \times N_L$
- $T_{cyl} = 50\text{ °C} \rightarrow 0.55 \times N_L$
- $T_{cyl} = 45\text{ °C} \rightarrow 0.3 \times N_L$

Peak output (over 10 minutes)

Relative to performance factor N_L
DHW heating from 10 to 45 °C

Cylinder capacity	l	300	390	500
Peak output				
at heating water flow temperature				
90 °C	l/10 min	415	540	690
80 °C	l/10 min	400	521	667
70 °C	l/10 min	357	455	596

Max. draw-off rate (over 10 minutes)

Relative to performance factor N_L
With reheating
DHW heating from 10 to 45 °C

Cylinder capacity	l	300	390	500
Max. draw-off rate				
at heating water flow temperature				
90 °C	l/min	41	54	69
80 °C	l/min	40	52	66
70 °C	l/min	35	46	59

Pressure drop on the heating water side

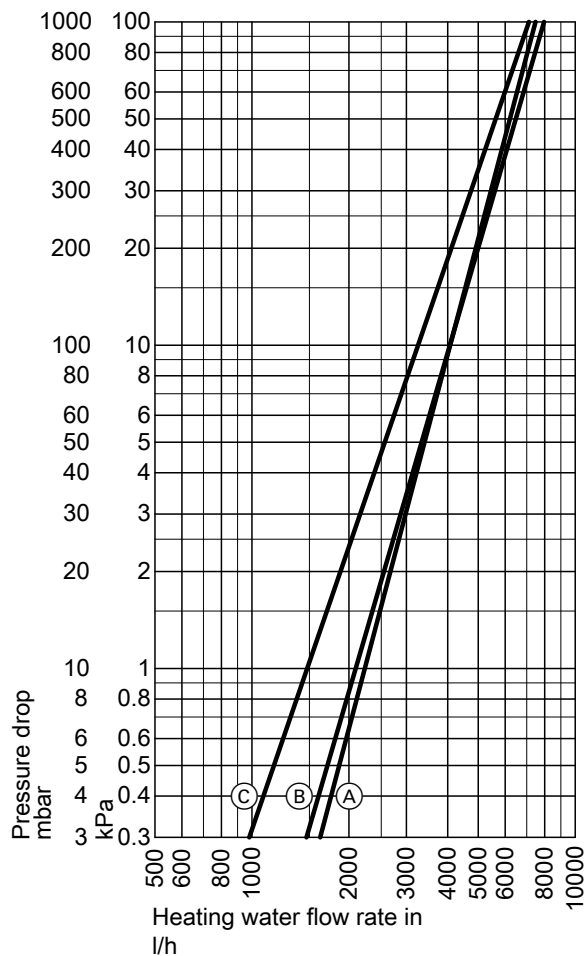

- (A) Cylinder capacity 300 l
- (B) Cylinder capacity 390 l
- (C) Cylinder capacity 500 l

Pressure drop on the DHW side

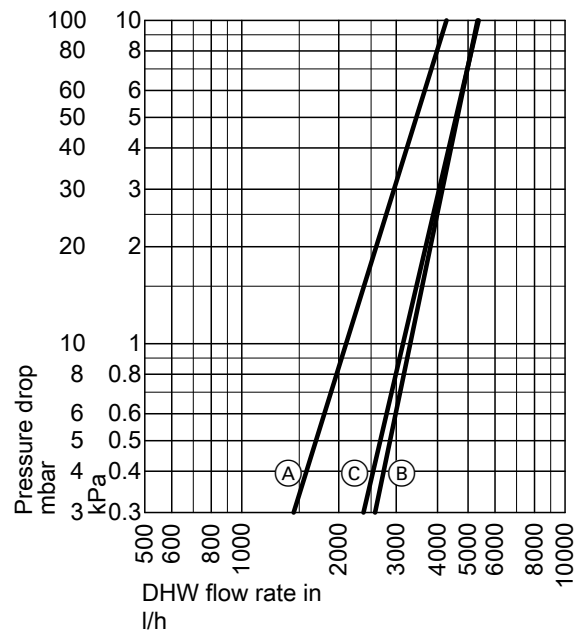

- (A) Cylinder capacity 300 l
- (B) Cylinder capacity 390 l
- (C) Cylinder capacity 500 l

EHE immersion heater

■ Part no. Z012677:

For installation in the flanged aperture in the **lower** section of the Vitocell 100-V, type CVWA with a cylinder capacity of **390 l**

■ Part no. Z012684:

For installation in the connector in the **upper** section of the Vitocell 100-V, type CVWA with a cylinder capacity of **390 l**

- Only use the immersion heater with soft to medium hard water with a calcium hardness up to 14 °dH (hardness level 2, up to 2.5 mol/m³).
- The heating output can be selected: 2, 4 or 6 kW

Components:

- High limit safety cut-out
- Temperature controller

Note

- A contactor relay, part no. 7814681, is required for switching the immersion heater via the heat pump.
- The immersion heaters are not intended for operation with 230 V~. If no 400 V connection is available, use commercially available immersion heaters.

Specification

Output	kW	2	4	6
Rated voltage		3/N/PE 400 V/50 Hz		
IP rating		IP 44		
Rated current	A	8.7	8.7	8.7
Heat-up time for heating from 10 to 60 °C				
– Immersion heater in the bottom section	h	8.5	4.3	2.8
– Immersion heater in the top section	h	4.0	2.0	1.3
Content that can be heated by the immersion heater				
– Immersion heater in the bottom section	l	294		
– Immersion heater in the top section	l	136		

Solar heat exchanger set

Part no. 7186663

For the connection of solar collectors to the Vitocell 100-V, type CVWA (390 and 500 l capacity)
Suitable for systems to DIN 4753. Total water hardness of up to 20 °dH (3.6 mol/m³)

Max. collector surface area that can be connected:

- 11.5 m² flat-plate collectors
- 6 m² tube collectors

Specification

Permissible temperatures	
Solar side	140 °C
Heating water side	110 °C
DHW side	
– For boiler operation	95 °C
– For solar operation	60 °C
Permissible operating pressure	
Solar side, heating and DHW side	10 bar (1.0 MPa)
Test pressure	
Solar side, heating and DHW side	13 bar (1.3 MPa)
Minimum wall clearance	
For installation of the solar heat exchanger set	350 mm
Circulation pump	
Power supply	230 V/50 Hz
IP rating	IP 42

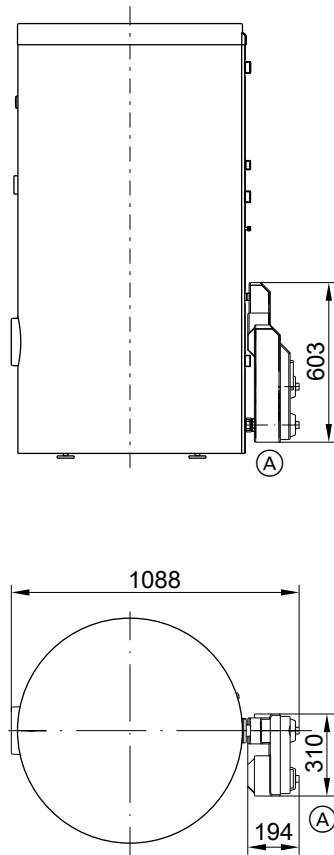

Ⓐ Solar heat exchanger set

Impressed current anode

Part no. Z004247

- Maintenance free
- For installation in the Vitocell 100-V, type CVWA in place of the supplied protective magnesium anode

Safety assembly to DIN 1988

Part no. 7180662, 10 bar (1 MPa)
AT: Part no. 7179666, 6 bar (0.6 MPa)

- DN 20/R 1
- Max. heat input: 150 kW

Components:

- Shut-off valve
- Non-return valve and test connector
- Pressure gauge connector
- Diaphragm safety valve

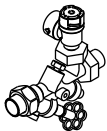

8.8 Accessories for DHW heating with cylinder loading system

Vitocell 100-V, type CVA/CVAA

For DHW heating in conjunction with boilers and district heating systems; optionally with an electric heater as an accessory for DHW cylinders with 300 and 500 l capacity

- Operating pressure on the **heating water side** up to **25 bar (2.5 MPa)**
- Operating pressure on the **DHW side** up to **10 bar (1.0 MPa)**

Suitable for the following systems:

- DHW temperature up to **95 °C**
- Heating water flow temperature up to **160 °C**

Specification

Type		CVAA	CVA	CVAA	CVAA	
Cylinder capacity (AT: Actual water capacity)	l	300	500	750	950	
Heating water capacity	l	10.0	12.5	29.7	33.1	
Gross volume	l	310.0	512.5	779.7	983.1	
DIN registration number		9W241/11–13 MC/E				
Continuous output for DHW heating from 10 to 45 °C and a heating water flow temperature of ... at the heating water flow rate stated below	90 °C	kW	53	70	109	116
		l/h	1302	1720	2670	2861
	80 °C	kW	44	58	91	98
		l/h	1081	1425	2236	2398
	70 °C	kW	33	45	73	78
		l/h	811	1106	1794	1926
60 °C	kW	23	32	54	58	
	l/h	565	786	1332	1433	
50 °C	kW	18	24	33	35	
	l/h	442	589	805	869	
Continuous output for DHW heating from 10 to 60 °C and a heating water flow temperature of ... at the heating water flow rate stated below	90 °C	kW	45	53	94	101
		l/h	774	911	1613	1732
	80 °C	kW	34	44	75	80
		l/h	584	756	1284	1381
	70 °C	kW	23	33	54	58
		l/h	395	567	923	995
Heating water flow rate for the stated continuous outputs	m ³ /h	3.0	3.0	3.0	3.0	
Standby heat loss	kWh/24 h	1.65	1.95	2.28	2.48	
Dimensions						
Length (∅)						
– With thermal insulation	a	mm	667	859	1062	1062
		mm	—	650	790	790
Width						
– With thermal insulation	b	mm	744	923	1110	1110
		mm	—	837	1005	1005
Height						
– With thermal insulation	c	mm	1734	1948	1897	2197
		mm	—	1844	1817	2123
Height when tilted						
– With thermal insulation		mm	1825	—	—	—
		mm	—	1860	1980	2286
Entire weight incl. thermal insulation	kg	156	181	301	363	
Heating surface	m ²	1.5	1.9	3.5	3.9	
Connections (male thread)						
Heating water flow and return	R	1	1	1¼	1¼	
Cold water, DHW	R	1	1¼	1¼	1¼	
DHW circulation	R	1	1	1¼	1¼	
Energy efficiency class		B	B	—	—	

Information regarding continuous output

When designing systems with the specified or calculated continuous output, select a matching circulation pump. The stated continuous output is achieved only if the rated boiler heating output is ≥ continuous output.

Note

Up to 300 l cylinder capacity also available as Vitocell 100-W in white.

Installation accessories (cont.)

Vitocell 100-V, type CVAA, 300 l capacity

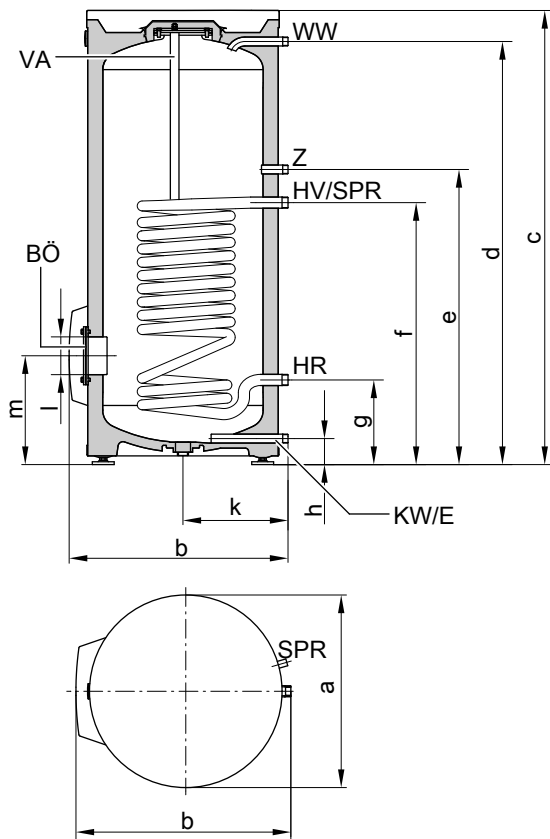

Dimensions

Cylinder capacity		l	300
Length (∅)	a	mm	667
Width	b	mm	744
Height	c	mm	1734
	d	mm	1600
	e	mm	1115
	f	mm	875
	g	mm	260
	h	mm	76
	k	mm	361
	l	mm	∅ 100
	m	mm	333

- BÖ Inspection and cleaning aperture
- E Drain
- HR Heating water return
- HV Heating water flow
- KW Cold water
- SPR Cylinder temperature sensor of the cylinder temperature controller or temperature controller (internal diameter of sensor well 16 mm)
- VA Protective magnesium anode
- WW DHW
- Z DHW circulation

Installation accessories (cont.)

Vitocell 100-V, type CVA, 500 l capacity

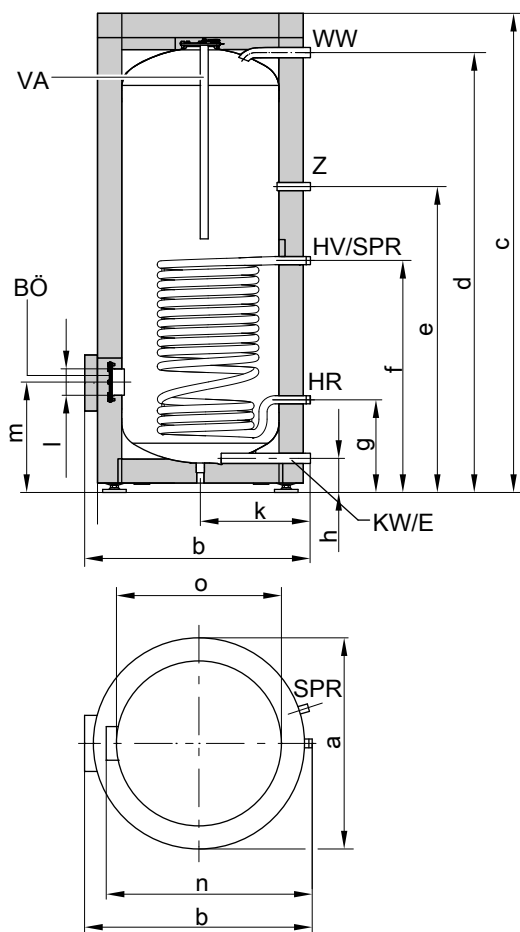

Dimensions

Cylinder capacity		l	500
Length (∅)	a	mm	859
Width	b	mm	923
Height	c	mm	1948
	d	mm	1784
	e	mm	1230
	f	mm	924
	g	mm	349
	h	mm	107
	k	mm	455
	l	mm	∅ 100
	m	mm	422
Excl. thermal insulation	n	mm	837
Excl. thermal insulation	o	mm	∅ 650

- BÖ Inspection and cleaning aperture
- E Drain
- HR Heating water return
- HV Heating water flow
- KW Cold water
- SPR Cylinder temperature sensor of the cylinder temperature controller or temperature controller (internal diameter of sensor well 16 mm)
- VA Protective magnesium anode
- WW DHW
- Z DHW circulation

Installation accessories (cont.)

Vitocell 100-V, type CVAA, 750 and 950 l capacity

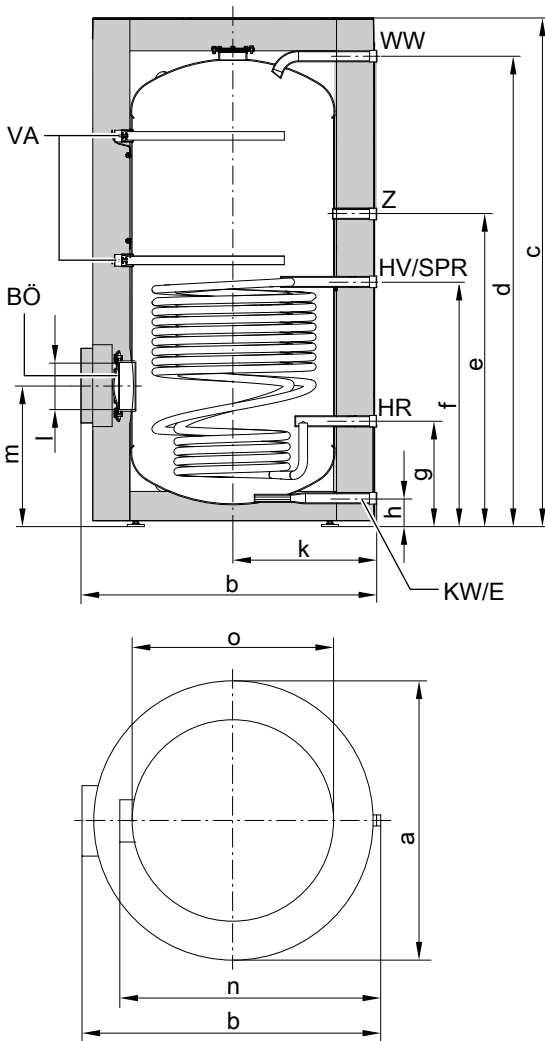

Dimensions

Cylinder capacity	l	750	950	
Length (∅)	a	mm	1062	1062
Width	b	mm	1110	1110
Height	c	mm	1897	2197
	d	mm	1788	2094
	e	mm	1179	1283
	f	mm	916	989
	g	mm	377	369
	h	mm	79	79
	k	mm	555	555
	l	mm	∅ 180	∅ 180
	m	mm	513	502
Excl. thermal insulation	n	mm	1005	1005
Excl. thermal insulation	o	mm	∅ 790	∅ 790

- BÖ Inspection and cleaning aperture
- E Drain
- HR Heating water return
- HV Heating water flow
- KW Cold water
- SPR Clamping system for fixing immersion temperature sensors to the cylinder jacket. Fixing points for 3 immersion temperature sensors per clamping system
- VA Protective magnesium anode
- WW DHW
- Z DHW circulation

Performance factor N_L

- To DIN 4708.
- Cylinder storage temperature T_{cyl} = cold water inlet temperature + 50 K ^{+5 K/-0 K}

Cylinder capacity	l	300	500	750	950
Performance factor N_L					
at heating water flow temperature					
90 °C		9.7	21.0	38.0	44.0
80 °C		9.3	19.0	32.0	42.0
70 °C		8.7	16.5	25.0	39.0

5822541

Installation accessories (cont.)

Information on performance factor N_L

The performance factor N_L depends on the cylinder storage temperature T_{cyl} .

Standard values

- $T_{cyl} = 60\text{ °C} \rightarrow 1.0 \times N_L$
- $T_{cyl} = 55\text{ °C} \rightarrow 0.75 \times N_L$
- $T_{cyl} = 50\text{ °C} \rightarrow 0.55 \times N_L$
- $T_{cyl} = 45\text{ °C} \rightarrow 0.3 \times N_L$

Peak output (over 10 minutes)

- Relative to performance factor N_L
- DHW heating from 10 to 45 °C

Cylinder capacity	l	300	500	750	950
Peak output					
at heating water flow temperature					
90 °C	l/10 min	407	618	850	937
80 °C	l/10 min	399	583	770	915
70 °C	l/10 min	385	540	665	875

Max. draw-off rate (over 10 min)

- Relative to performance factor N_L
- With reheating
- DHW heating from 10 to 45 °C

Cylinder capacity	l	300	500	750	950
Max. draw-off rate					
at heating water flow temperature					
90 °C	l/min	41	62	85	94
80 °C	l/min	40	58	77	92
70 °C	l/min	39	54	67	88

Drawable water volume

- Cylinder content heated to 60 °C
- Without reheating

Cylinder capacity	l	300	500	750	950
Draw-off rate					
	l/min	15	15	20	20
Drawable water volume					
Water at $t = 60\text{ °C}$ (constant)					
	l	240	420	615	800

Heat-up time

The heat-up times will be achieved when the maximum continuous output of the DHW cylinder is made available at the relevant heating water flow temperature and when DHW is heated from 10 to 60 °C.

Cylinder capacity	l	300	500	750	950
Heat-up time					
at heating water flow temperature					
90 °C	min	23	28	23	35
80 °C	min	31	36	31	45
70 °C	min	45	50	45	70

Pressure drop on the heating water side

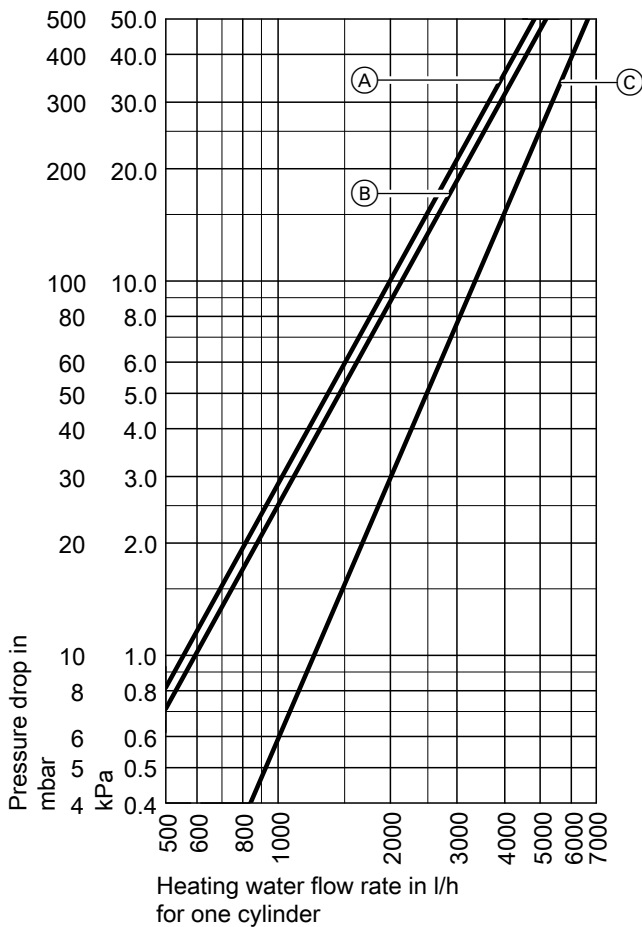

- (A) Cylinder capacity 500 l
- (B) Cylinder capacity 300 l
- (C) Cylinder capacity 750 l and 950 l

Pressure drop on the DHW side

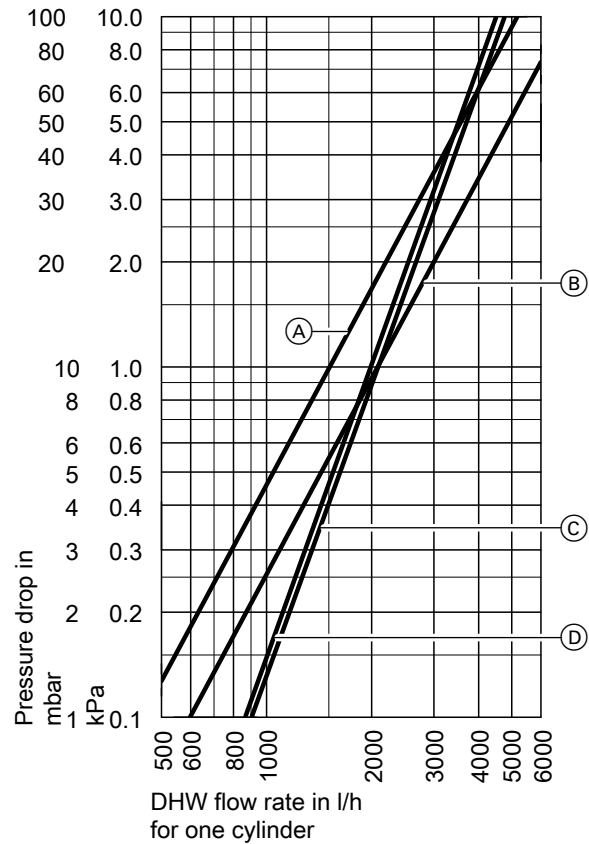

- (A) Cylinder capacity 300 l
- (B) Cylinder capacity 500 l
- (C) Cylinder capacity 750 l
- (D) Cylinder capacity 950 l

Vitocell 100-L, type CVL/CVLA

Cylinder for DHW heating in a cylinder loading system

Suitable for systems with the following parameters:

- Max. DHW temperature in the cylinder **95 °C**
- Operating pressure on the **DHW side up to 10 bar (1.0 MPa)**

Specification

Type		CVL	CVLA	CVLA	
Cylinder capacity (AT: Actual water capacity)	l	500	750	950	
DIN registration number		0256/08-13	Applied for		
Standby heat loss	kWh/24 h	1.95	2.28	2.48	
Dimensions					
Length (∅)					
– Incl. thermal insulation	a	mm	859	1062	1062
– Excl. thermal insulation		mm	650	790	790
Width					
– Incl. thermal insulation	b	mm	923	1110	1110
– Excl. thermal insulation		mm	837	1005	1005
Height					
– Incl. thermal insulation	c	mm	1948	1897	2197
– Excl. thermal insulation		mm	1844	1817	2123
Height when tilted					
– Excl. thermal insulation		mm	1860	1980	2286

5822541

Installation accessories (cont.)

Type		CVL	CVLA	CVLA
Cylinder capacity (AT: Actual water capacity)	I	500	750	950
Weight, cylinder				
– Excl. thermal insulation	kg	136	235	284
– Incl. thermal insulation	kg	156	260	314
Connections (male thread)				
DHW inlet from the heat exchanger	R	2	2	2
Cold water, DHW	R	2	2	2
DHW circulation, drain outlet	R	1¼	1¼	1¼
Energy efficiency class		B	—	—

500 l capacity

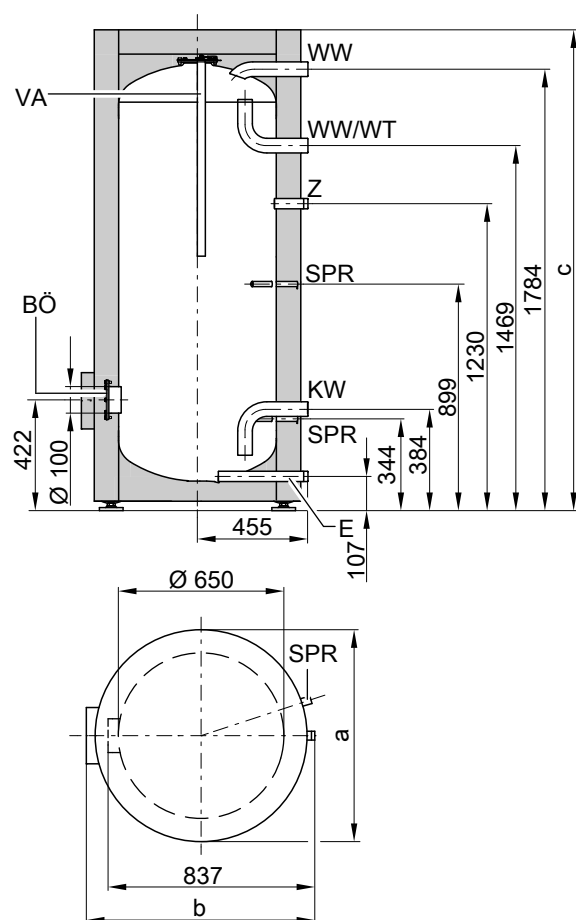

Dimensions

Cylinder capacity	I	500
Length (Ø)	a	mm
Width	b	mm
Height	c	mm

- BÖ Inspection and cleaning aperture
- E Drain
- KW Cold water
- SPR Sensor well for cylinder temperature sensor and temperature controller (internal diameter 16 mm)
- VA Protective magnesium anode
- WW DHW
- WW/WT Hot water inlet from the heat exchanger
- Z DHW circulation

Installation accessories (cont.)

750 and 950 l capacity

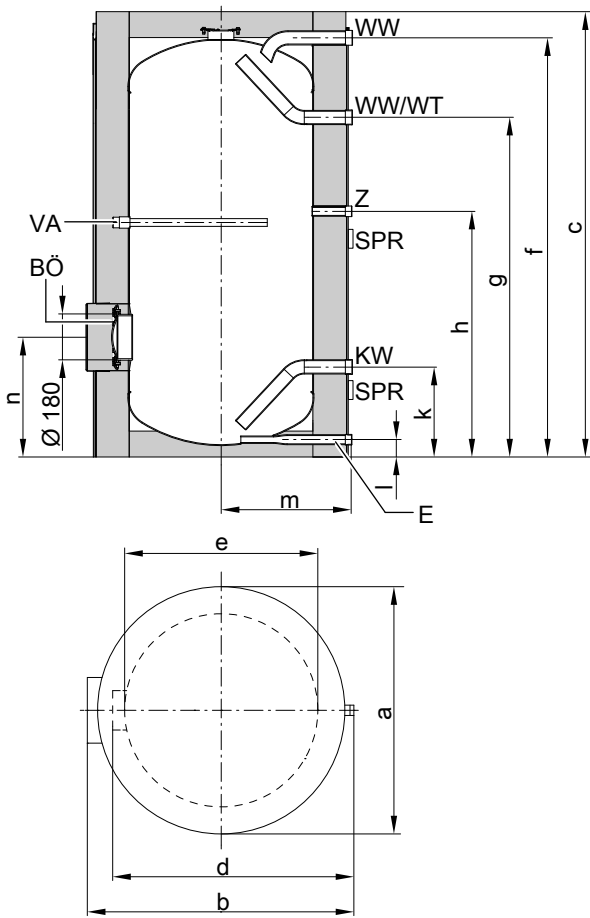

Dimensions

Cylinder capacity		l	750	950
Length (∅)	a	mm	1062	1062
Width	b	mm	1110	1110
Height	c	mm	1897	1897
	d	mm	1005	1005
∅ excl. thermal insulation	e	mm	790	790
	f	mm	1785	2090
	g	mm	1447	1752
	h	mm	1049	1285
	k	mm	338	379
	l	mm	79	79
	m	mm	555	555
	n	mm	514	506

- BÖ Inspection and cleaning aperture
- E Drain
- KW Cold water
- SPR Clamping system for fixing immersion temperature sensors to the cylinder jacket. Fixing points for 3 immersion temperature sensors
- VA Protective magnesium anode
- WW DHW
- WW/WT Hot water inlet from the heat exchanger
- Z DHW circulation

Pressure drop on the DHW side

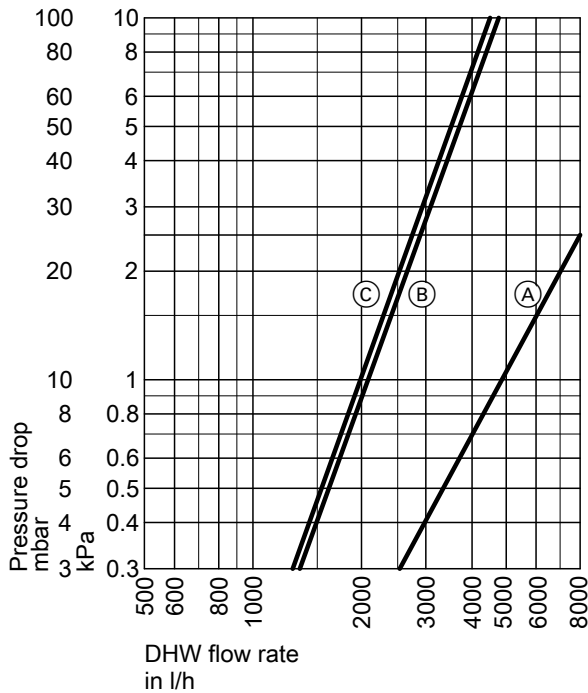

- (A) 500 l cylinder capacity
- (B) 750 l cylinder capacity
- (C) 950 l cylinder capacity

Heating lance

For DHW heating with a heat pump via an external heat exchanger (cylinder loading system).

Part no. ZK00038

- For installation in the flanged aperture of the Vitocell 100-V, type CVAA with a cylinder capacity of **300 l**

Part no. ZK00037

- For installation in the flanged aperture of the Vitocell 100-L, type CVL with a cylinder capacity of **500 l**

Heating lance made from plastic suitable for potable water applications

- Tube with end cap and several openings
- Flange
- Gasket
- Flange hood.

Note

The heating lance may be used in conjunction with an EHE immersion heater.

Circulation pump for cylinder loading

For DHW heating via an on-site plate heat exchanger:

- Grundfos UPS 25-60 B
Part no. 7820403
- Grundfos UPS 32-80 B
Part no. 7820404

Curves

Type UPS 25-60 B, 230 V~

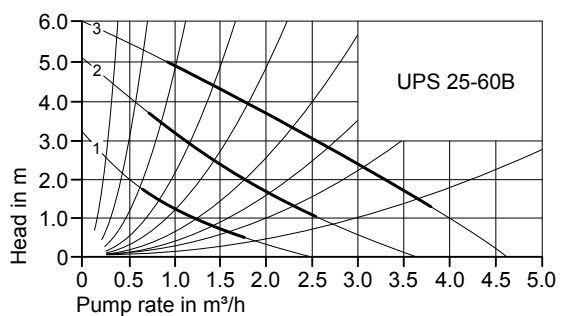

Power consumption: 45 to 90 W

Installation accessories (cont.)

Type UPS 32-80 B, 230 V~

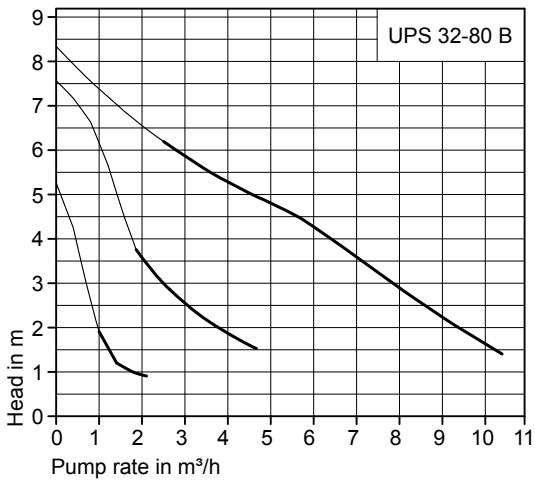

Power consumption: 135 to 225 W

2-way motorised ball valve (DN 32)

Part no. 7180573

To heat DHW with a primary store system; may be used as a shut-off valve.

- With electric drive (230 V~)
- Connection R 1¼

8.9 Accessories for DHW heating with freshwater module/heating water storage

Vitocell 120-E, type SVW, 600 l

For storing heating water in conjunction with heat pumps up to 17.2 kW rated heating output; DHW heating with Vitotrans 353; option to integrate an immersion heater and a conventional heat generator

- Operating pressure on the heating water side up to 3 bar (0.3 MPa)
- Operating pressure on the DHW side up to 10 bar (1.0 MPa)

Suitable for the following systems:

- DHW temperature up to 95 °C
- Heating water flow temperature up to 95 °C

Specification

Type		SVW	
Cylinder capacity	I	600	
AT: Actual water content			
– DHW zone (top) for Vitotrans 353	I	350	
– Heating circuit zone (bottom)	I	250	
Vitotrans 353	Type	PZSA	PZMA
Continuous output (in conjunction with Vitocal 16 kW rated heating output) For DHW heating from 10 to 45 °C and heating water flow temperature			
55 °C	kW	15	15
	l/h	372	372
Draw-off rate	l/min	20	20
Drawable water volume without reheating			
– DHW zone heated to 55 °C; water at T = 45 °C (constant)	I	315	315
– DHW zone heated to 60 °C; water at T = 45 °C (constant)	I	345	345
– DHW zone heated to 65 °C; water at T = 45 °C (constant)	I	380	380
DHW zone heat-up time (in conjunction with Vitocal) For heating from 15 to 50 °C and a rated heating output of			
9 kW	min	84	84
13 kW	min	58	58
16 kW	min	57	57
DHW zone heat-up time (in conjunction with Vitocal) For heating from 15 to 55 °C and a rated heating output of			
9 kW	min	90	90
13 kW	min	62	62
16 kW	min	50	50
Max. connectable rated heating output of a heat pump		kW	17.2
Continuous output (in conjunction with conventional heat generators) For DHW heating from 10 to 45 °C and a heating water flow temperature of ... at the heating water flow rate stated below			
90 °C	kW	81	146
	l/h	1980	3600
80 °C	kW	81	146
	l/h	1980	3600
70 °C	kW	81	146
	l/h	1980	3600
60 °C	kW	61	117
	l/h	1500	2880
55 °C	kW	52	100
	l/h	1260	2460
Continuous output (in conjunction with conventional heat generators) For DHW heating from 10 to 60 °C and a heating water flow temperature of ... at the heating water flow rate stated below			
90 °C	kW	108	195
	l/h	1860	3360
80 °C	kW	88	164
	l/h	1500	2820
70 °C	kW	65	127
	l/h	1140	2220
Heating water flow rate for the stated continuous outputs		m ³ /h	3.0
Standby heat loss		kWh/24 h	2.1

Installation accessories (cont.)

Type		SVW	
Cylinder capacity	I	600	
AT: Actual water content			
Dimensions			
Complete with Vitotrans 353 and thermal insulation			
– Length (∅)	mm	1064	1064
– Total width	mm	1466	1466
– Height	mm	1645	1645
Heating water buffer cylinder (cylinder body)			
– Length (∅)	mm	790	790
– Width	mm	1062	1062
– Height	mm	1520	1520
Height when tilted without adjustable feet	mm	1630	1630
Weight			
– Complete with Vitotrans 353 and thermal insulation	kg	143	150
– Heating water buffer cylinder without thermal insulation	kg	96	96
– Heating water buffer cylinder with thermal insulation	kg	119	119
Heating water buffer cylinder connections			
– Heating water flow and return (male thread)	R	1¼	
– Heating water flow heating lance (male thread)	G	1½	
– Immersion heater (female thread)	Rp	1½	
Energy efficiency class		B	

For a more detailed specification of and accessories for Vitotrans 353, see "Vitotrans 353" datasheet.

Information regarding continuous output

When designing systems with the specified or calculated continuous output, select a matching circulation pump. The stated continuous output is only achieved if the rated heating output of the heat generator is \geq the continuous output.

DHW temperature in conjunction with heating water buffer cylinder and freshwater module

Where planning measures must ensure a DHW temperature of at least 60 °C at the outlet of the freshwater module, a heat pump operating in mono mode can **only** provide basic heating of the heating water buffer cylinder. Complete heating up to the set buffer temperature must be provided by means of an additional heat generator, e.g. an electric instantaneous heating water heater or peak load boiler.

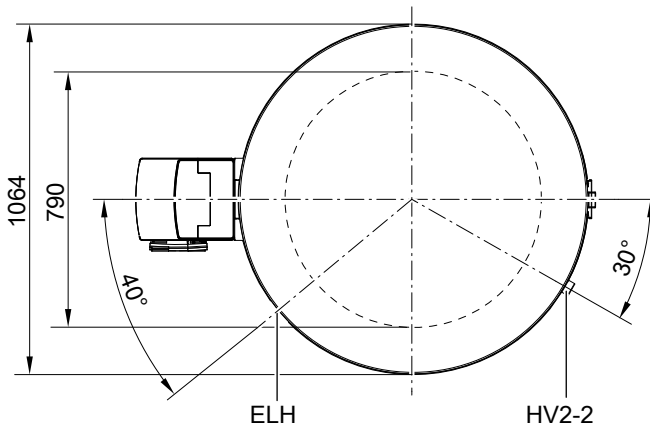
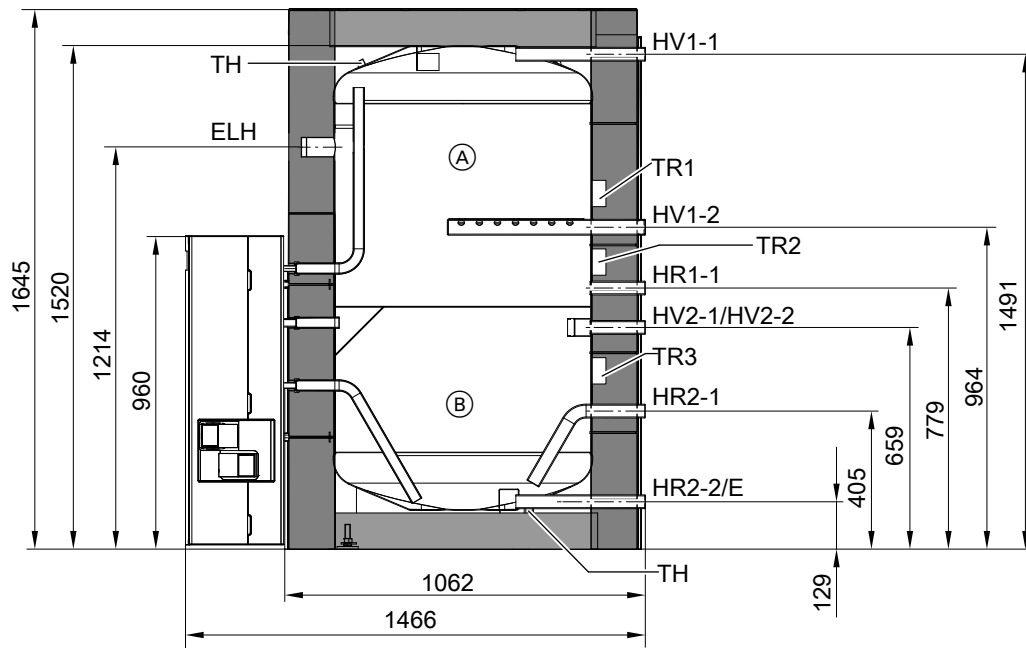

- Ⓐ DHW zone
- Ⓑ Heating circuit zone
- E Drain
- ELH Immersion heater
- HR1-1 Heating water return, DHW zone (heat pump/external heat generator)
- HR2-1 Heating water return, heating circuit zone (heat pump)
- HR2-2 Heating water return (heating circuit)
- HV1-1 Heating water flow, DHW zone (external heat generator)
- HV1-2 Heating water flow, DHW zone (heat pump to heating lance)
- HV2-1 Heating water flow, heating circuit zone (heat pump)
- HV2-2 Heating water flow (heating circuit)
- TH Retainer for thermometer sensor or additional sensor (clamping bracket)
- TR Clamping system for fixing immersion temperature sensors to the cylinder jacket. Fixing points for 3 immersion temperature sensors per clamping system

Pressure drop

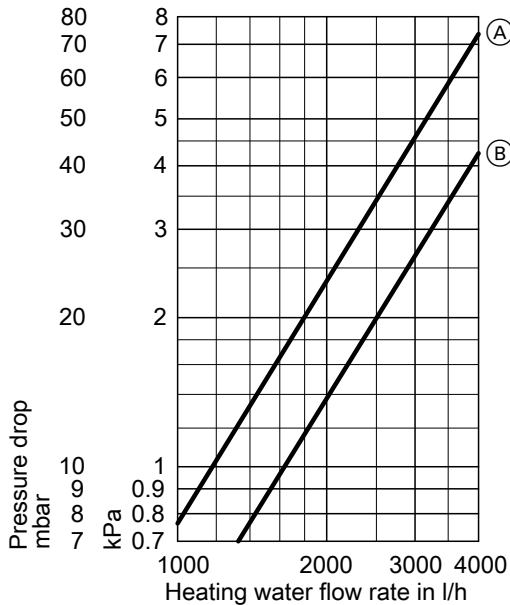

- (A) DHW zone
- (B) Heating circuit zone

Vitocell 120-E, type SVW, 950 l

Note

Specifications for the Vitocell 120-E, type SVW with 950 l cylinder capacity are available in a separate datasheet. See www.vibooks.de.

Immersion heater EHE

Part no. Z014468

- Optional heating output: 2, 4 or 6 kW
- For installation in the Vitocell 120-E, type SVW
- Only use with soft to medium hard water up to 14 °dH (hardness level 2 to 2.5 mol/m³)

Components:

- High limit safety cut-out
- Temperature controller

Note

A contactor relay, part no. 7814681, is required for switching the immersion heater via the heat pump.

Specification

Output	kW	2	4	6
Rated voltage		1/N/PE 230 V/50 Hz		3/PE 400 V/50 Hz
Rated current	A	8.7	17.4	8.7
IP rating		IP 45	IP 45	IP 45
Heat-up time from 10 °C to 60 °C	h	3.5	1.7	1.2
Content that can be heated by the immersion heater	l	120		

Part no. Z014469

- Optional heating output: 4, 8 or 12 kW
- For installation in the Vitocell 120-E, type SVW
- Only use with soft to medium hard water up to 14 °dH (hardness level 2 to 2.5 mol/m³)

Components:

- High limit safety cut-out
- Temperature controller

Note

A contactor relay, part no. 7814681, is required for switching the immersion heater via the heat pump.

Specification

Output	kW	4	8	12
Rated voltage		2/PE 400 V/50 Hz		3/PE 400 V/50 Hz
Rated current	A	10.0	20.0	17.3
IP rating		IP 45	IP 45	IP 45
Heat-up time from 10 °C to 60 °C	h	1.7	0.9	0.6
Content that can be heated by the immersion heater	l	120		

3-way diverter valve

Connection (male thread)	Dimension in mm			Part no.
	a	b	c	
G 1	145	82	103	ZK01343
G 1½	161	139	109	ZK01344
G 2	174	106	115	ZK01353

- With electric drive
- For the hydraulic connection of a heating water buffer cylinder to the freshwater module

Note

Available system examples:

See www.viessmann-schemes.com.

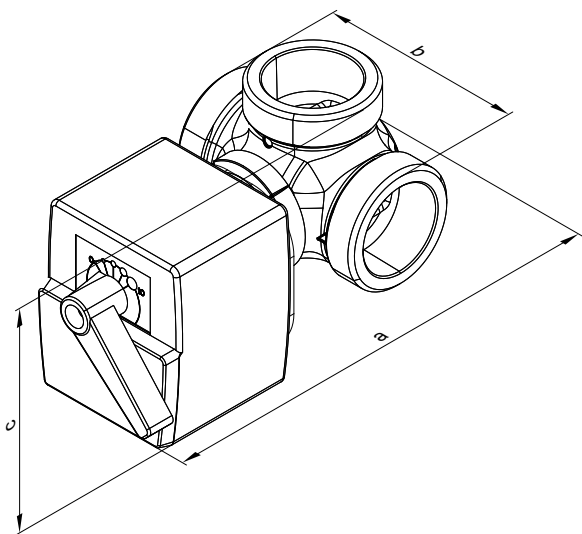

Pressure drop graphs

3-way diverter valve with G 1 connection

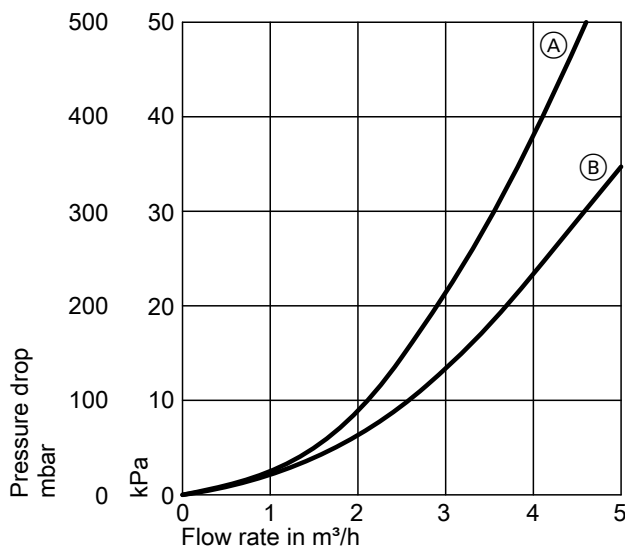

- (A) Diverted flow
- (B) Straight flow

Installation accessories (cont.)

3-way diverter valve with G 1½ connection

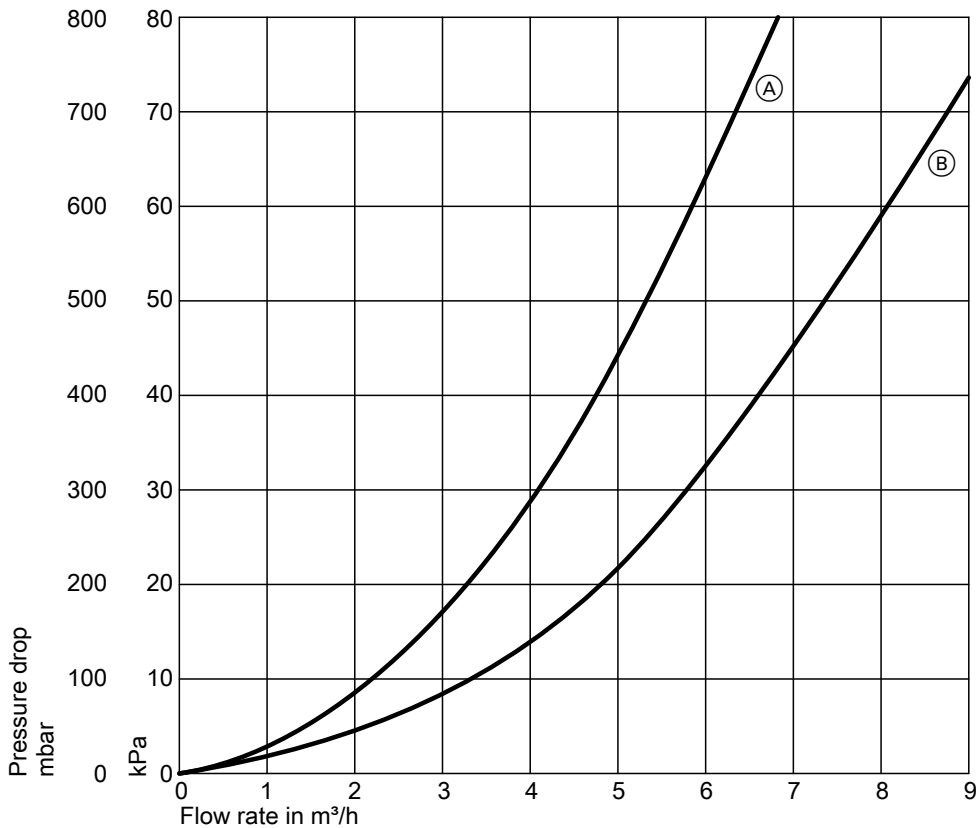

- Ⓐ Diverted flow
- Ⓑ Straight flow

3-way diverter valve with G 2 connection

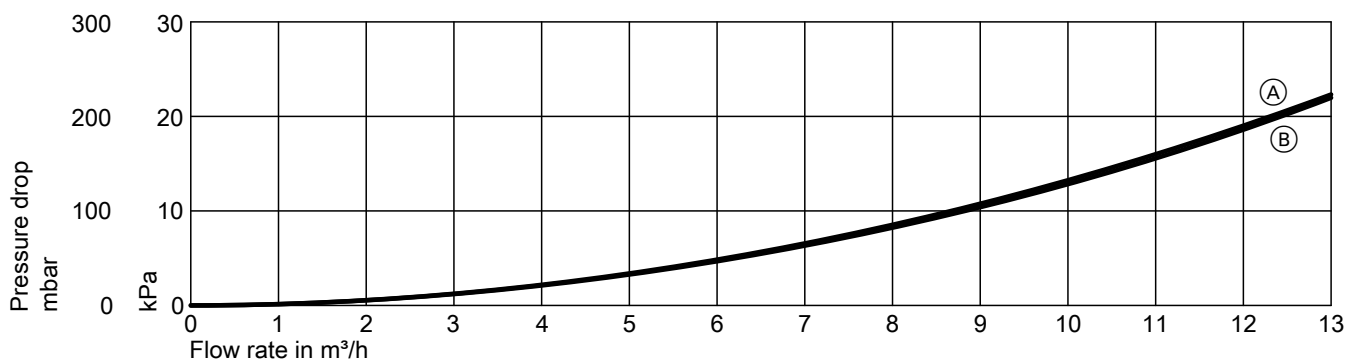

- Ⓐ Diverted flow
- Ⓑ Straight flow

8.10 Accessories for DHW heating with integral DHW cylinder

Safety assembly to DIN 1988

Part no. 7180662, 10 bar (1 MPa)
 AT: Part no. 7179666, 6 bar (0.6 MPa)

■ DN 20/R 1
 ■ Max. heat input: 150 kW

5822541

Installation accessories (cont.)

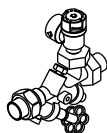

Components:

- Shut-off valve
- Non-return valve and test connector
- Pressure gauge connector
- Diaphragm safety valve

Impressed current anode

Part no. 7182008

- Maintenance free
- Install in place of the magnesium anode supplied

8.11 Installation accessories

Platform for unfinished floors

Part no. 7417925

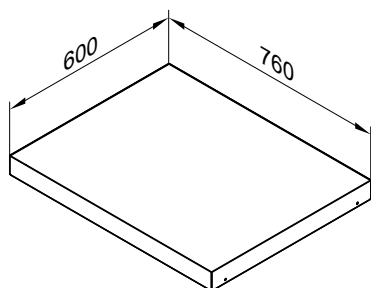

- With adjustable feet, for screed heights between 10 and 18 cm.
- For installation of the appliance on unfinished floors; suitable for siting tight against the wall.
- Incl. thermal insulation.

Note

In the case of installation flush with the wall, insert edge insulation strips for sound insulation between the platform for unfinished floors and the wall.

Tundish set

Part no. 7176014

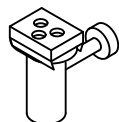

Tundish with trap and bezel: DN 40

Transport aid for heat pump module

Part no. ZK04568

For straightforward removal and carrying of the heat pump module by 2 persons

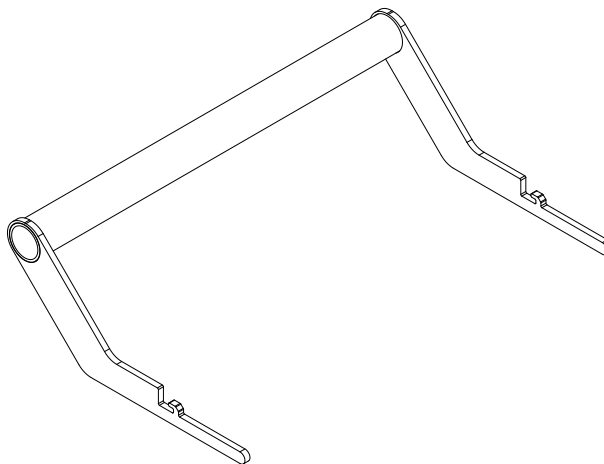

8.12 Cooling

NC-Box

Part no.: ZK01836

Pre-assembled unit with mixer, for implementing the natural cooling function. The cooling function can optionally be used on a heating/cooling circuit or on a separate cooling circuit.

For connection, for example, to underfloor heating systems, fan convectors or chilled ceilings.

Max. cooling capacity 5 kW (subject to the heat pump and cooling source used).

Direct control by the heat pump control unit ("NC signal")

Components:

- Plate heat exchanger
- Frost protection valve
- Frost stat
- Natural cooling contact humidistat
- Primary HE circulation pump for the cooling circuit
- Secondary HE circulation pump for the cooling circuit
- 3-way diverter valve (heating/cooling)
- 3-way mixer with motor
- Thermally and sound insulated, vapour diffusion-proof EPP casing

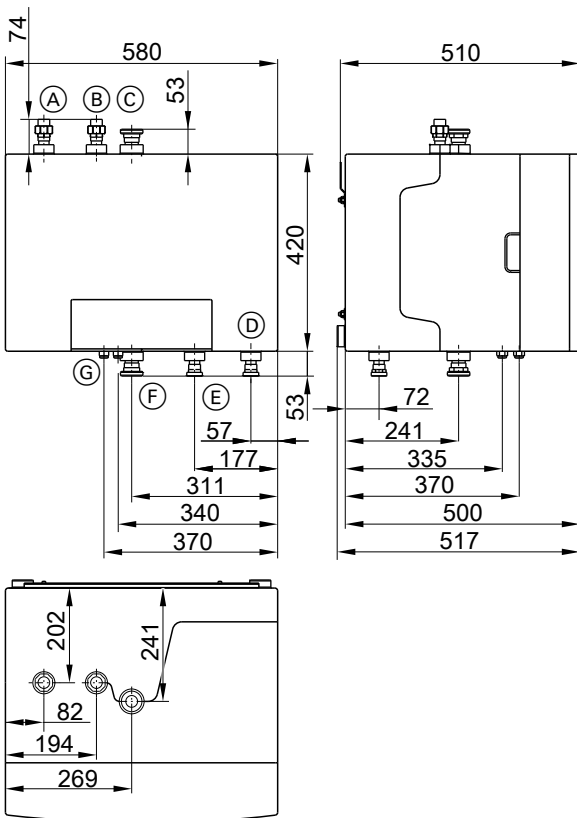

- (A) Return, heating/cooling circuit or separate cooling circuit
- (B) Flow, heating/cooling circuit or separate cooling circuit
- (C) Flow, primary circuit (brine inlet, NC-Box)
- (D) Return, secondary circuit to the heat pump
- (E) Flow, secondary circuit to the NC-Box
- (F) Flow, primary circuit (brine outlet, NC-Box)
- (G) Cable entry

Information regarding the cooling capacity

The expected cooling capacity largely depends on the sizing and type of heat source.

The cooling capacity is at its highest at the end of the heating season. The cooling capacity diminishes as the ground warms up.

Specification

Expected cooling capacity subject to the heat pump output	
- 16 kW	approx. 5.00 kW
- 8 kW	approx. 2.50 kW
- 4 kW	approx. 1.25 kW

Permissible ambient temperature

- Operation	+2 to +30 °C
- Handling and storage	-30 to +60 °C

Dimensions

- Total length	520 mm
- Total width	580 mm
- Total height	420 mm

Weight

	28 kg
--	-------

Connections

- Flow, primary circuit (brine inlet and outlet, NC-Box)	G 1½
- Flow and return, heating/cooling circuit, separate cooling circuit	G 1
- Flow and return, secondary circuit to the heat pump	G 1

Energy efficiency index EEI

- Primary high efficiency circulation pump for the cooling circuit	≤ 0.20
- Secondary high efficiency circulation pump for the cooling circuit	≤ 0.20

Note

- The NC-Box can be used only up to the rated heating output of 17.2 kW.
- Two-stage heat pumps:
In conjunction with a two-stage heat pump, the NC-Box cannot be installed immediately above the heat pumps. The hydraulic lines between the heat pumps are fitted above the heat pumps.

Hydraulic connection set, NC-Box

Part no.: ZK01958

Pre-assembled pipework assembly to connect the heat pump and NC-Box.

For installation of the NC-Box above the heat pump.

- Flow and return lines for cooling and heating water
- Flow line, brine
- Thermal insulation (vapour diffusion-proof)

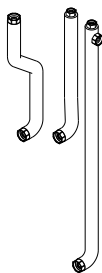

Note

- The NC-Box hydraulic connection set **cannot** be used in conjunction with a heating water buffer cylinder.
- The NC-Box hydraulic connection set can **only** be used in conjunction with the Vitocal 200-G, type BWC and Vitocal 300-G, type BWC.

AC-Box

Part no.: ZK01834

Pre-assembled unit without mixer for implementing the active cooling function. The cooling function can optionally affect one heating/cooling circuit or a separate cooling circuit.

For connection of chilled ceilings or fan convectors, for example.

Max. cooling capacity up to 13 kW (subject to the heat pump and cooling source used).

Note

- To ensure the reliable transfer of the cooling capacity, no mixer is provided for the cooling circuit. Utilisation in conjunction with an underfloor heating circuit is therefore not recommended.
- The AC-Box can only be used up to the rated heating output of 17.0 kW. For higher rated heating outputs, install all the components required on site (with correspondingly sized plate heat exchanger) for the heating/cooling circuit or the separate cooling circuit.
- Installation of the AC-Box only to the left of the heat pump.

Components:

- Plate heat exchanger
- Diverter valves
- Frost stat
- Cooling circuit pump
- Control of the natural cooling function
- Thermally and sound insulated, vapour diffusion-proof casing

Installation accessories (cont.)

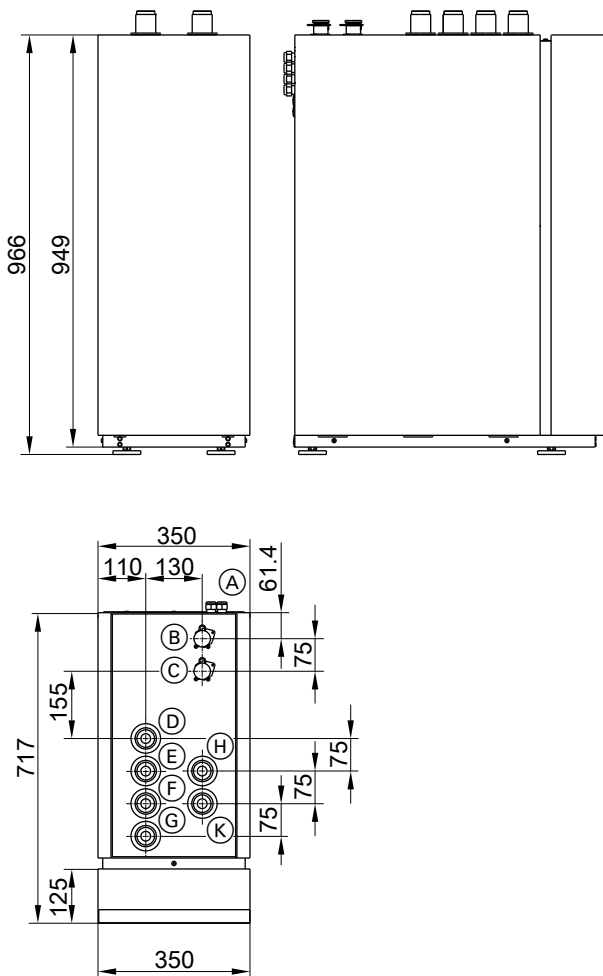

- Ⓐ Cable entries
- Ⓑ Flow, secondary circuit to the AC-Box
- Ⓒ Return, secondary circuit to the heat pump
- Ⓓ Return, heating/cooling circuit or separate cooling circuit
- Ⓔ Flow, heating/cooling circuit or separate cooling circuit
- Ⓕ Primary circuit flow (brine inlet, AC-Box)
- Ⓖ Primary circuit return (brine outlet, AC-Box)
- Ⓗ Primary circuit return (heat pump brine outlet)
- Ⓚ Primary circuit flow (heat pump brine inlet)

Specification

Dimensions	
Length	717 mm
Width	350 mm
Height	973 mm
Weight (empty)	approx. 80 kg
Permiss. ambient temperature	
Operation	+2 to +30 °C
Handling and storage	-30 to +60 °C
Test pressure	max. 4.5 bar
Connections	
Primary circuit flow and return (brine inlet and outlet, AC-Box)	G1 ¼
Consumer (cooling)	G1 ¼
Brine connection to the heat pump	G 1 ¼
Heating water connection to the heat pump	Multi connect system DN 20
2-way valves	
Operating voltage (AC mode)	230 V/50 Hz
Power consumption	1.5 W
IP rating	IP 54
3-way valve	
Operating voltage (AC mode)	230 V/50 Hz
Power consumption	5 W
IP rating	IP 20
Opening time	10 s
Closing time	4 s
Circulation pumps	
Operating voltage (AC mode)	230 V/50 Hz
Output (per pump)	max. 150 W
Speed stages	3
Energy efficiency index EEI	≤ 0.21
Power supply	1/N/PE 230 V/50 Hz

Connection accessories for AC-Box

Part no. 7452606

Prefabricated pipe assembly for connecting the Vitocal 300-G, type BWC to the AC-Box

- For siting the AC-Box to the left of the heat pump
- Not suitable for systems with heating water buffer cylinder

Components:

- Flow and return, heating/cooling circuit or separate cooling circuit
- Flow and return, primary circuit return (brine inlet/outlet)
- Thermal insulation (vapour diffusion-proof)
- Connection pieces between pipework and AC-Box as well as heat pump
- Air vent valve (1 per pipe)

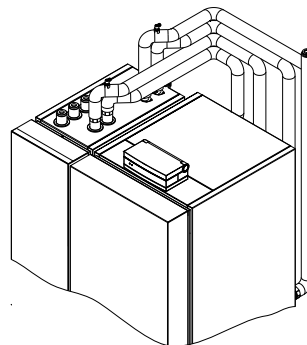

Installation accessories (cont.)

Contact humidistat 24 V

Part no. 7181418

- Dew point contact switch
- To prevent the formation of condensate when cooling via a heating circuit

Natural cooling extension kit

Part no. 7179172

- PCB for processing signals and controlling the natural cooling function
- Connection plug
- Installation accessories

3-way diverter valve (R 1¼)

Part no. 7165482

- With electric drive (230 V~)
- Connection R 1¼

Frost stat

Part no. 7179164

Safety switch to protect the cooling heat exchanger from frost.

Connection set

Part no. 7180574

For direct connection to the appliance.

Components:

- 2 push-fit connectors with female thread R ¾ and O-ring seals.

2-way motorised ball valve (DN 32)

Part no. 7180573

To heat DHW with a primary store system; may be used as a shut-off valve.

- With electric drive (230 V~)
- Connection R 1¼

Contact temperature sensor

Part no. 7426463

For capturing the flow temperature of the separate cooling circuit or the heating circuit without mixer, if it is designed as a cooling circuit.

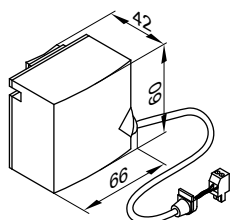

Secured with a tie.

Specification

Lead length	5.8 m, fully wired
IP rating	IP 32D to EN 60529; ensure through design/installation.
Sensor type	Viessmann NTC 10 kΩ at 25 °C
Permissible ambient temperature	
– Operation	0 to +120 °C
– Storage and transport	–20 to +70 °C

Room temperature sensor for separate cooling circuit

Part no. 7438537

Install in the room to be cooled on an internal wall, opposite radiators/heat sinks. Never install inside shelving units, in recesses, or immediately adjacent to a door or heat source (e.g. direct sunlight, fireplace, TV set etc.).

Connect the room temperature sensor to the control unit.

Connection:

- 2-core lead with a cross-section of 1.5 mm² (copper)
- Lead length from the remote control up to 30 m
- Never route this lead immediately next to 230/400 V cables.

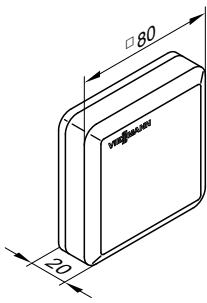

Specification

Protection class	III
IP rating	IP 30 to EN 60529; ensure through design/installation.
Sensor type	Viessmann NTC 10 kΩ at 25 °C
Permissible ambient temperature	
– Operation	0 to +40 °C
– Storage and transport	-20 to +65 °C

8.13 Solar

Solar collectors

See Viessmann pricelist

Max. connectable collector area

- 4.6 m² Vitosol 200-F/300-F
- 3 m² Vitosol 200-T/300-T

Solar heat exchanger set (Divicon)

Part no. ZK04099

For connecting solar thermal systems to heat pump compact appliances

- Connections matched to Solar-Divicon for direct mounting below the Solar-Divicon
- Suitable for systems to DIN 4753. Up to a total water hardness of 20 °dH (3.6 mol/m³)
- Max. collector surface area that can be connected:
 - 5 m² flat-plate collectors
 - 3 m² tube collectors

Components:

- Circulation pump
- Plate heat exchanger
- Connection pipes G 3/4 (male thread)
- Sensor well for the cylinder temperature sensor of the solar control module, type SM1
- Thermal insulation
- Connection elbow with sensor well

Note

The hydraulic connections for the solar circuit can optionally be routed either upwards or downwards from the appliance.

Hydraulic connections upwards and downwards

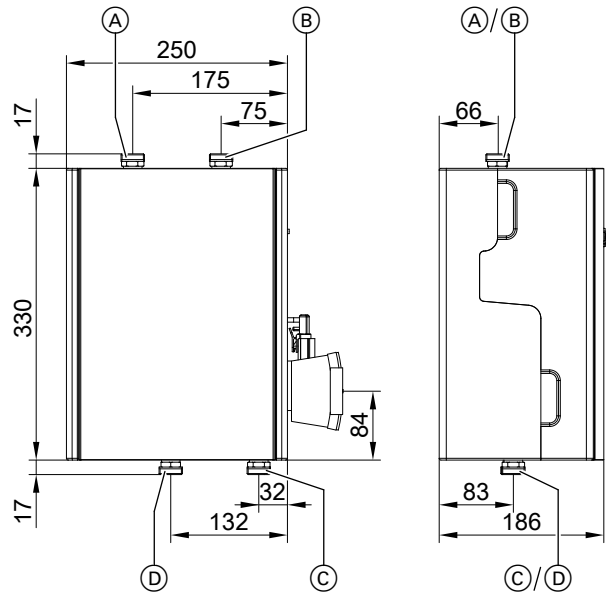

- (A) Solar circuit return
- (B) Solar circuit flow
- (C) DHW cylinder return
- (D) DHW cylinder flow

Specification

Permissible temperatures	
Solar side	140 °C
Heating water side	110 °C
DHW side	
– For boiler operation	95 °C
– For solar operation	60 °C
Permissible operating pressure	10 bar (1.0 MPa)
Solar side, heating and DHW side	
Test pressure	13 bar (1.3 MPa)
Solar side, heating and DHW side	
Circulation pump	
Power supply	230 V/50 Hz
IP rating	IP 42

Installation accessories (cont.)

Hydraulic connections downwards

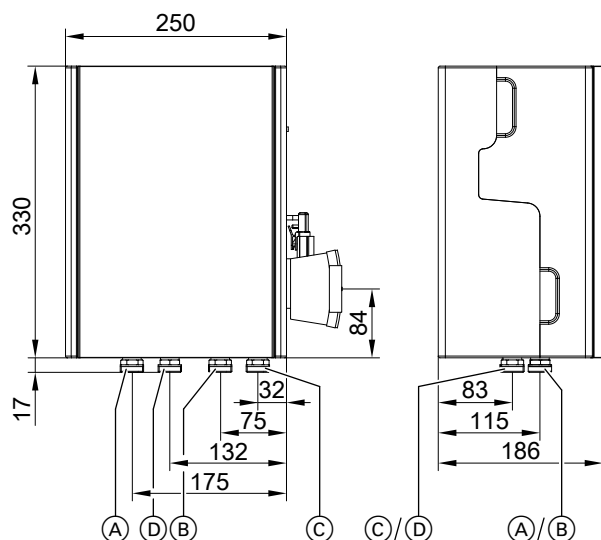

- (A) Solar circuit return
- (B) Solar circuit flow
- (C) DHW cylinder return
- (D) DHW cylinder flow

Solar Divicon, type PS10

Part no. Z017690

Pump station for the collector circuit

- With variable speed high efficiency circulation pump for alternating current
Delivery head: 6.0 m at a pump rate of 1000 l/h
- Integrated SDIO/SM1A electronics module for solar control
- For apertures of up to 40 m² in area for Vitosol 200-F, 300-F, 200-T and 300-T
The aperture area details refer to "low flow systems" and are subject to the system pressure drop: See technical guide for solar collectors.

Installation accessories (cont.)

Design

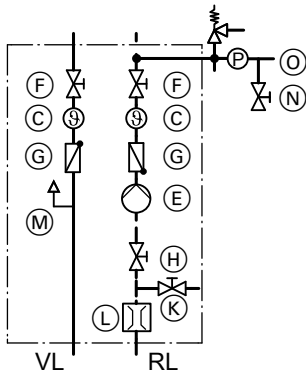
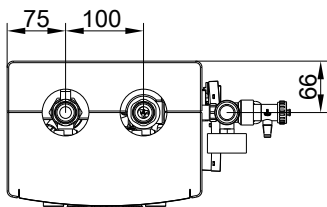
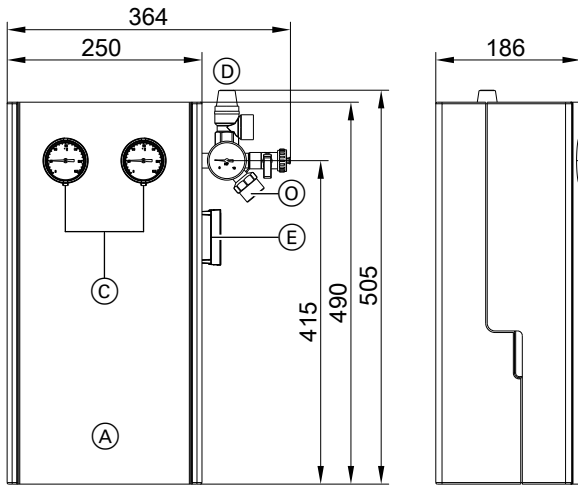

- (A) Solar-Divicon
- (C) Thermometer
- (D) Safety assembly (safety valve 6 bar, pressure gauge 10 bar)

- (E) High efficiency circulation pump
- (F) Shut-off valves
- (G) Non-return valves
- (H) Shut-off valve
- (K) Drain valve
- (L) Flow indicator
- (M) Air separator
- (N) Fill valve
- (O) Expansion vessel connection
- RL Return
- VL Flow

Safety valve in conjunction with Vitosol-FM switching flat-plate collector

Up to a system height of 20 m, the Solar-Divicon may be used with the 6 bar safety valve.

At system heights over 20 m, the safety valve may be replaced with an 8 bar safety valve (see "Vitosol" accessories).

Compact heat pumps

The permissible operating pressure in solar circuits linked to compact heat pump appliances is 6 bar.

Vitosol-FM collectors can only be used in conjunction with compact heat pump appliances where the system height is 20 m maximum.

Specification

Type	PS10
High efficiency circulation pump	Wilo Para 15/7.0
– Energy efficiency index EEI	≤ 0.20
Rated voltage	230 V~
Power consumption	
– Min.	3 W
– Max.	45 W
Flow indicator	1 to 13 l/min
Safety valve (solar)	
– At the factory	6 bar
	0.6 MPa
– When replacing	10 bar
	1 MPa
Max. operating temperature	120 °C
Max. operating pressure	10 bar
	1 MPa
Connections (locking ring fitting/double O-ring)	
– Solar circuit	22 mm
– Expansion vessel	22 mm

Installation accessories (cont.)

Curve

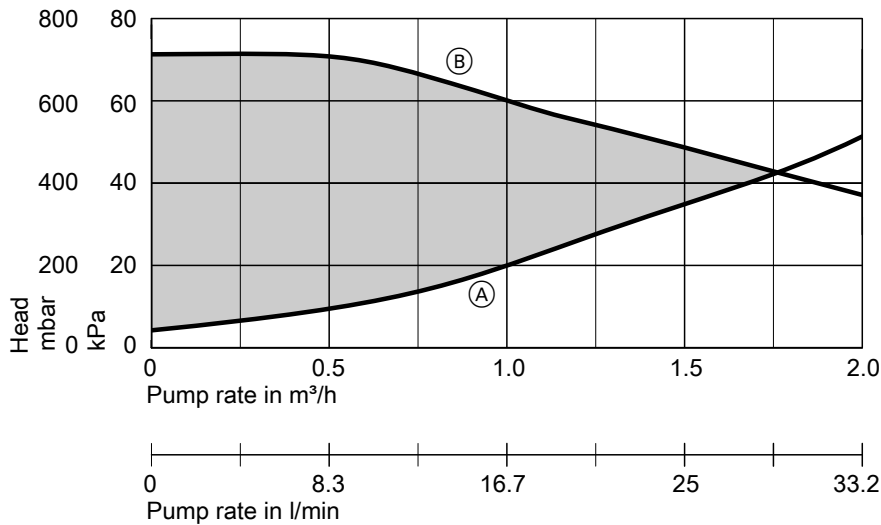

- (A) Pressure drop curve
(B) Max. delivery head

High limit safety cut-out for solar thermal system

Part no. 7506168

- With a thermostatic system
- With stainless steel sensor well R ½ x 200 mm
- With setting scale and reset button in casing

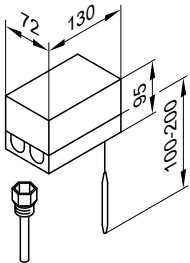

Specification

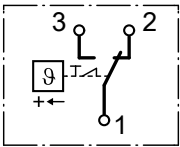
Connection	3-core lead with a cross-section of 1.5 mm ²
IP rating	IP 41 to EN 60529
Switching point	120 (110, 100, 95) °C
Max. switching differential	11 K
Breaking capacity	6 (1.5) A, 250 V~
Switching function	with rising temperature from 2 to 3 
DIN reg. no.	DIN STB 98108 or DIN STB 116907

Collector temperature sensor

Part no. 7831913

Immersion temperature sensor for installation in the solar collector

- For systems with 2 collector arrays
- For heat statement (recording flow temperature)

On-site extension of the connecting lead:

- 2-core lead, length up to 60 m with a cross-section of 1.5 mm² (copper)
- Never route this lead immediately next to 230/400 V cables.

Specification

Lead length	2.5 m
IP rating	IP 32 to EN 60529; ensure through design/installation
Sensor type	Viessmann NTC 20 kΩ at 25 °C
Permissible ambient temperature	
– Operation	–20 to +200 °C
– Storage and transport	–20 to +70 °C

Heat transfer medium "Tyfocor LS"

Part no. 7159727

- Ready-mixed to –28 °C
- 25 l in a disposable container

Tyfocor LS can be mixed with Tyfocor G-LS.

Design information

9.1 Power supply and tariffs

According to current Federal tariffs [Germany], the electrical demand for heat pumps is considered domestic usage. Where heat pumps are used to heat buildings, the local power supply company must first give permission [check with your local power supply company]. Check the connection conditions specified by your local power supply utility for the stated equipment details. It is crucial to establish whether a mono-mode and/or mono-energetic heat pump operation is feasible in the supply area.

It is also important to obtain information about standing charges and energy tariffs, about the options for utilising off-peak electricity during the night and about any power-off periods. Address any questions relating to these issues to your customer's local power supply utility.

Application procedure

The following details are required to assess the effect of the heat pump operation on the grid of your local power supply utility:

- User address
- Location where the heat pump is to be used
- Type of demand in accordance with general tariffs (domestic, agricultural, commercial, professional and other use)

- Intended heat pump operating mode
- Heat pump manufacturer
- Type of heat pump
- Connected load in kW (from rated voltage and rated current)
- Max. starting current in A
- Max. heat load of the building in kW

9.2 Installation requirements

- The installation room must be dry and safe from the risk of frost.
- Never install the appliance in living spaces or directly next to, below or above quiet rooms/bedrooms.
- In conjunction with an ice store system:
Never site in rooms containing washing machines or dryers.
- Maintain the minimum clearances and minimum room volume (see the following chapter).
- Sound insulation measures:
 - Reduction of reverberative surfaces, particularly on walls and ceilings. Rough structural renders absorb more sound than tiles.
 - If quietness is a particularly important consideration, apply sound-absorbing material to the walls and ceilings (commercially available).
 - We recommend you never install this device on wooden floors in the roof space, to prevent the transmission of structure-borne noise.
 - The doors of the installation room should at minimum correspond to emission protection category E1. This is usually achieved simply by fitting tubular chipboard doors.
- Hydraulic connections:
 - Always make hydraulic heat pump connections flexible and stress-free.
 - Apply anti-vibration fixings to pipework and installations.
 - To prevent condensation, thermally insulate lines and components in the primary circuit with vapour diffusion-proof materials.
 - Provide corresponding installation areas for accessories and expansion vessels on the brine side.

Siting Vitocal 200-G, 300-G, 350-G

Minimum clearances

Note

Additional strain relief clamps are required for the power cables if the clearance behind the heat pump is more than 80 mm.

Design information (cont.)

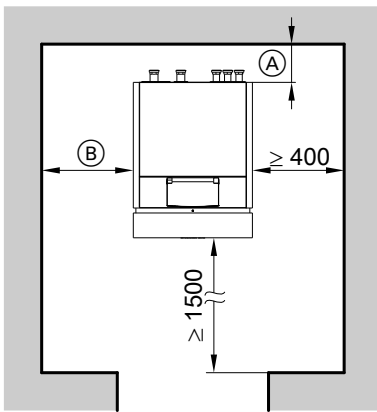

Type BW, BWC

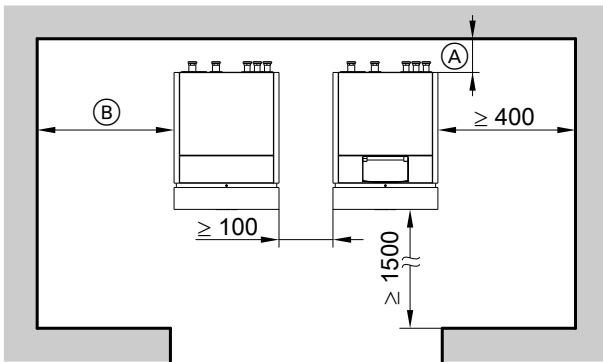

Type BWS+BW

Observe clearances for installation and maintenance.
When using the AC-Box (accessories), see page 172.

Notes

- Type BWS (stage 2) is always positioned to the left of type BW (stage 1).
- Make the hydraulic connections between the two heat pumps above both heat pumps (connection set, accessories or on site).
- The NC-Box (accessories) **must not** be positioned directly above the heat pumps (NC-Box see page 127).
- When using the AC-Box (accessories), see page 172.

- Ⓐ Subject to on-site installation and site conditions
- Ⓑ
- With AC-Box (accessories, for installation to the left of the heat pump):
≥ 400 mm (+ width of the AC-Box)
 - Without AC-Box:
≥ 100 mm

Design information (cont.)

Siting the Vitocal 222-G, 333-G

Minimum room height

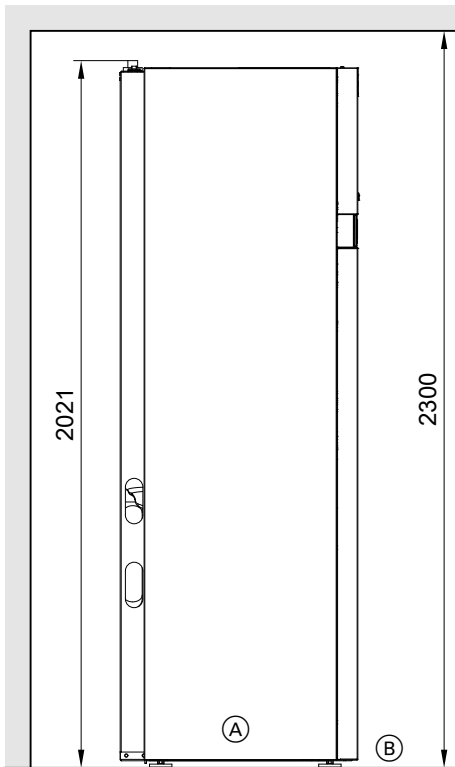

- (A) Compact heat pump
- (B) Finished floor level or top edge of platform for unfinished floors

Minimum clearances

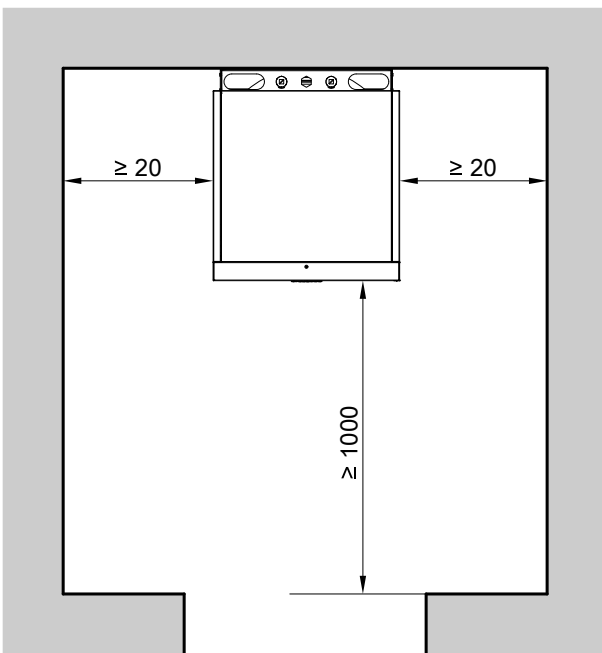

Siting in conjunction with Vitovent 300-F
See "Vitovent" technical guide.

Pressure points

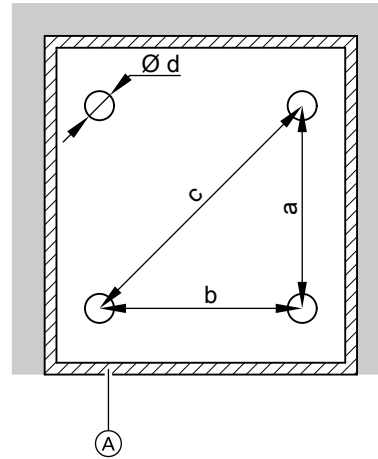

- (A) Partition joint with edge insulation strip as part of the floor construction
- a 484 mm
- b 480 mm
- c 657 mm
- d 64 mm

Each pressure point (each with an area of 3217 mm²) is subject to a load of up to 132 kg.

Total weight with filled DHW cylinder, Vitocal 222-G

Type	Weight in kg	
BWT-M	221.B06	497
	221.B08	502
	221.B10	508

Total weight with filled DHW cylinder, Vitocal 333-G

Type	Weight in kg	
BWT	331.C06	485
	331.C12	495

Design information (cont.)

Minimum room volume

According to EN 378, the minimum volume of the installation room depends on the refrigerant charge and composition.

$$V_{\min} = \frac{m_{\max}}{G}$$

V_{\min} Minimum room volume in m³

m_{\max} Maximum refrigerant charge in kg

G Practical limit to EN 378, subject to the composition of the refrigerant

Refrigerant	Practical limit in kg/m ³
R410A	0.44
R407C	0.31

Note

If several heat pumps are to be installed in one room, the minimum room volume must be calculated according to the appliance with the greatest refrigerant charge.

Taking into account the refrigerant used and the refrigerant charge, the following minimum room volumes result:

Vitocal	Minimum room volume in m ³
200-G	
BWC 201.A06	2.7
BWC 201.A08	3.3
BWC 201.A10	3.9
BWC 201.A13	5.0
BWC 201.A17	6.6

Vitocal	Minimum room volume in m ³
300-G, single stage and two-stage	
BW, BWS, BWC 301.B06	3.2
BW, BWS, BWC 301.B08	4.4
BW, BWS, BWC 301.B10	5.5
BW, BWS, BWC 301.B13	5.1
BW, BWS, BWC 301.B17	6.3
BW, BWS 301.A21	10.7
BW, BWS 301.A29	14.1
BW, BWS 301.A45	17.5
350-G, single stage and two-stage	
BW, BWS 351.B20	12.5
BW, BWS 351.B27	16.6
BW, BWS 351.B33	20.5
BW, BWS 351.B42	21.0
222-G	
BWT-M 221.B06	3.2
BWT-M 221.B08	4.5
BWT-M 221.B10	5.5
333-G	
BWT 331.C06	5.3
BWT 331.C12	6.5

9.3 Electrical connections for central heating and DHW heating

- Observe the technical connection requirements specified by your local power supply utility.
- Your local power supply utility will provide you with details regarding the required metering and switching equipment.
- We recommend the provision of a separate electricity meter for the heat pump.

Viessmann heat pumps operate with 400 V~. In some countries, 230 V models are also available.

The control circuit requires a power supply of 230 V~.

The control circuit fuse (6.3 A) is located in the heat pump control unit.

Power-OFF

It is possible for the power supply utility to shut down the compressor and instantaneous heating water heater (if installed). The ability to carry out such a shutdown may be a power supply utility requirement for providing a lower tariff.

This must **not** shut off the power supply to the Vitotronic control unit.

Electrical connections, single stage heat pump: Vitocal 200-G, 300-G, 350-G

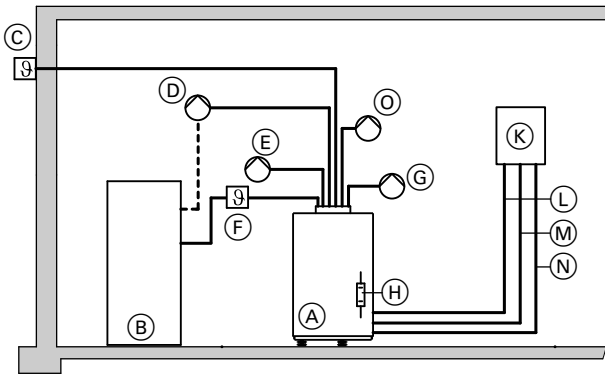

Type BW

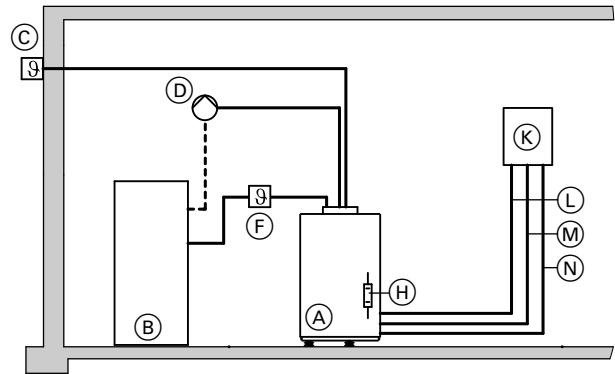

Type BWC

- (A) Heat pump
- (B) DHW cylinder
- (C) Outside temperature sensor, sensor lead (2 x 0.75 mm²)
- (D) DHW circulation pump, power cable (3 x 1.5 mm²)
- (E) Circulation pump, primary circuit (brine), power cable (3 x 1.5 mm² or 5 x 1.5 mm² for circulation pump with thermal relay)
If a 400 V~ circulation pump is used, it should be connected via a contactor relay.
- (F) Cylinder temperature sensor, sensor lead (2 x 0.75 mm²)
- (G) Secondary pump, power cable (3 x 1.5 mm²)
Further circulation pumps are required for heating water buffer cylinders, heating circuits with mixers and external heat generators.
- (H) Instantaneous heating water heater (accessories)
- (K) Electricity meter/mains
- (L) Compressor power cable, 400 V~ (5 x 2.5 mm², subject to heat pump type (max. 30 m))
- (M) Heat pump control unit power cable, 230 V~, 50 Hz (5 x 1.5 mm² with power-OFF contact)
- (N) Power cable, 400 V~ for instantaneous heating water heater (accessory, 5 x 2.5 mm², activation via heat pump control unit)
- (O) Circulation pump for cylinder heating (heating water side), power cable (3 x 1.5 mm²)

- (A) Heat pump (with integral circulation pumps for primary and secondary circuits and diverter valve for DHW heating)
- (B) DHW cylinder
- (C) Outside temperature sensor, sensor lead (2 x 0.75 mm²)
- (D) DHW circulation pump, power cable (3 x 1.5 mm²)
- (F) Cylinder temperature sensor, sensor lead (2 x 0.75 mm²)
- (H) Instantaneous heating water heater (accessories)
- (K) Electricity meter/mains
- (L) Compressor power cable, 400 V~ (5 x 2.5 mm², subject to heat pump type (max. 30 m))
- (M) Heat pump control unit power cable, 230 V~, 50 Hz (5 x 1.5 mm² with power-OFF contact)
- (N) Power cable, 400 V~ for instantaneous heating water heater (accessory, 5 x 2.5 mm², activation via heat pump control unit)

Using water/water: Note the following additional components:

- Well pump (If a 400 V~ well pump is used, it should be connected via a contactor relay.)
- Flow switch
- Frost stat
- Separating heat exchanger

Note

When installing additional heating water buffer cylinders, heating circuits with mixer, external heat generators (gas/oil/wood) etc., allow for the additionally required supply and control cables and sensor leads.

Check the core cross-section of the power cables and enlarge if required.

Electrical connections on 2-stage heat pump: Vitocal 300-G, 350-G

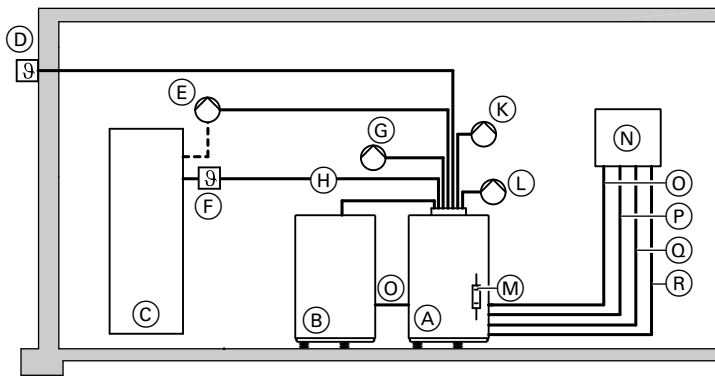

Type BWS+BW

- (A) Heat pump, type BW
- (B) Heat pump, type BWS
- (C) DHW cylinder
- (D) Outside temperature sensor, sensor lead (2 x 0.75 mm²)
- (E) DHW circulation pump, power cable (3 x 1.5 mm²)
- (F) Cylinder temperature sensor, sensor lead (2 x 0.75 mm²)
- (G) Circulation pump, primary circuit (brine), power cable (3 x 1.5 mm² or 5 x 1.5 mm² for circulation pump with thermal relay)
If a 400 V~ circulation pump is used, it should be connected via a contactor relay.
With the two-stage heat pump, either a common primary pump can be used for both stages, or a separate primary pump can be used for each stage.
- (H) Electrical connecting cables between heat pump stage 1 and 2 (standard delivery)
- (K) Circulation pump for cylinder heating (heating water side), power cable (3 x 1.5 mm²)
With 2-stage heat pumps, two DHW circulation pumps can be used for cylinder heating (one for each stage).
- (L) Secondary pump, power cable (3 x 1.5 mm²)
Two secondary pumps are required for 2-stage heat pumps (one for each stage).
Further circulation pumps are required for heating water buffer cylinders, heating circuits with mixers and external heat generators.
- (M) Instantaneous heating water heater (accessory, installation only in type BW)
- (N) Electricity meter/mains
- (O) Compressor power cable, type BWS, 400 V~ (5 x 2.5 mm², subject to heat pump type, up to 30 m)
- (P) Compressor power cable, type BW, 400 V (5 x 2.5 mm², subject to heat pump type, up to 30 m)
- (Q) Heat pump control unit power cable, 230 V~, 50 Hz (5 x 1.5 mm² with power-OFF contact)
- (R) Power cable, 400 V~ for instantaneous heating water heater (accessory, 5 x 2.5 mm², activation via heat pump control unit)

Using water/water: Note the following additional components:

- Well pump (If a 400 V~ well pump is used, it should be connected via a contactor relay.)
- Flow switch

- Frost stat
- Separating heat exchanger

Electrical connections Vitocal 222-G

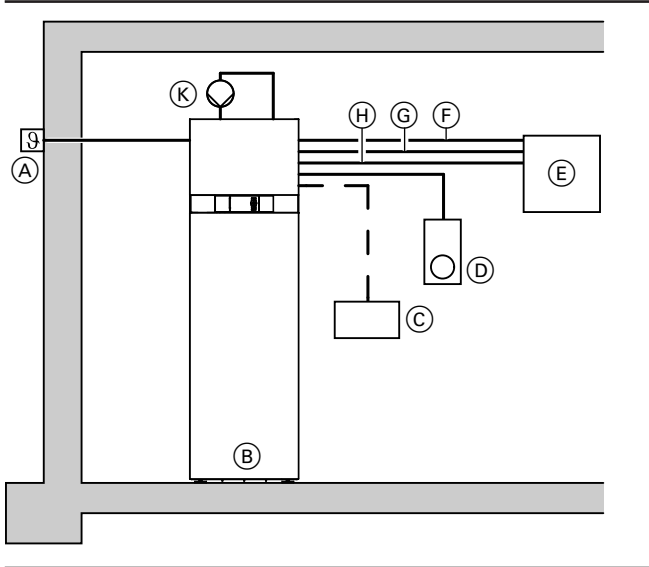

- (A) Outside temperature sensor, sensor lead (2 x 0.75 mm²)
- (B) Compact heat pump
- (C) Natural cooling switching contact, for switching the underfloor heating system with central hook-up, power cable (5 x 1.5 mm²)
- (D) Vitotrol 200 remote control, power cable (2 x 0.75 mm²)
- (E) Electricity meter/domestic mains supply
- (F) Power cable for compressor: See following table.
- (G) Power cable for instantaneous heating water heater: See following table.
- (H) Power cable for heat pump control unit: See following table.
- (K) DHW circulation pump, power cable (3 x 1.5 mm²)

Recommended power cables

Power supply	Cable	Max. cable length	Fuse rating
Heat pump control unit 230 V~	– Without power-OFF	3 x 1.5 mm ²	B16A
	– With power-OFF	5 x 1.5 mm ²	B16A
Instantaneous heating water heater 230 V~	7 x 2.5 mm ²	25 m	B16A

Compressor 230 V~

Type	Cable	Max. cable length	Fuse rating
BWT-M	221.B06	3 x 2.5 mm ²	25 m B16A
	221.B08	3 x 2.5 mm ²	25 m B20A
	221.B10	3 x 2.5 mm ²	25 m B25A

Electrical connections Vitocal 333-G

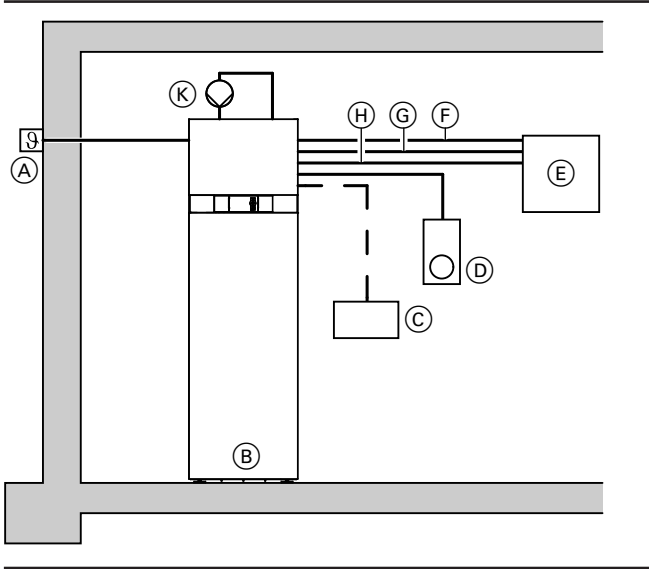

- (A) Outside temperature sensor, sensor lead (2 x 0.75 mm²)
- (B) Compact heat pump
- (C) Natural cooling switching contact, for switching the underfloor heating system with central hook-up, power cable (5 x 1.5 mm²)
- (D) Vitotrol 200 remote control, power cable (2 x 0.75 mm²)
- (E) Electricity meter/domestic mains supply
- (F) Power cable for compressor: See following table.
- (G) Power cable for instantaneous heating water heater: See following table.
- (H) Power cable for heat pump control unit: See following table.
- (K) DHW circulation pump, power cable (3 x 1.5 mm²)

Recommended power cables

Power supply	Cable	Max. cable length	Fuse rating
Heat pump control unit 230 V~	- Without power-OFF	3 x 1.5 mm ²	B16A
	- With power-OFF	5 x 1.5 mm ²	B16A
Instantaneous heating water heater 400 V~	5 x 2.5 mm ²	25 m	B16A

Compressor 400 V~

Type	Cable	Max. cable length	Fuse rating
BWT	331.C06	5 x 2.5 mm ²	25 m B16A
	331.C12	5 x 2.5 mm ²	25 m B16A

9.4 Information on hydraulic connection

System examples

Available system examples: See www.viessmann-schemes.com.

Two-stage heat pumps

- If the stage 1 and 2 heat pumps (type BW+BWS) are installed with the same rated heating outputs, the identical flow rates mean that **one** primary pump can be used.
- If the stage 1 and 2 heat pumps (type BW and BWS) are installed with different rated heating outputs, **two** primary pumps must be used, due to the differing flow rates.

The on-site primary pump for the 2nd stage cannot be connected to the heat pump control unit via a PWM signal. The settings must be performed on the primary pump's control unit.

Heat pump cascade

A heat pump cascade consists of a lead heat pump and up to 4 lag heat pumps. Each lag heat pump has a heat pump control unit. Both the lead and lag heat pumps can have 2 stages.

The lead heat pump regulates operation of the heat pumps within the cascade.

- The following communication modules (accessories) must be fitted in the heat pump control units:
 - Lead heat pump: LON communication module for cascade control
 - Lag heat pumps: LON communication module
- Depending on the system equipment level, all heat pumps in a cascade can be separately enabled via LON for different functions. This is done with the parameter **"Use of heat pump in cascade 700C"**:
 - Central heating/room cooling
 - DHW heating
 - Swimming pool heating
 Several functions can be active simultaneously.

The DHW cylinder return may only be connected to the heat pump stage 1.

9.5 Sizing the heat pump

First establish the standard heat load Φ_{HL} of the building. For discussions with customers and for the preparation of a quotation, in most cases estimating the heat load is adequate.

As with all heating systems, determine the standard heat load of the building to EN 12831 before ordering the appropriate heat pump.

Mono mode operation

According to EN 12831, the heat pump system in mono mode must, as sole heat source, be able to cover the entire heat demand of the building.

For mono mode operation, the potential outside temperatures at the installation site and the heat pump application limits must be taken into account:

For minimum air inlet temperature and minimum flow temperature, see chapter "Application limits to EN 14511".

Please also note that, in mono mode, the heat pump heating output and the maximum secondary circuit flow temperature are influenced by the outside temperature. This can result in comfort losses, for DHW heating in particular.

Therefore please note the following design points:

- Check whether the maximum heat pump flow temperature, achieved at the prevailing outside temperatures, fulfils the local DHW heating requirements.
- During commissioning or service, the secondary circuit temperature may lie below the required minimum heat pump flow temperature. The heat pump compressor does not then run independently.
- If frost protection mode is permanently enabled (e.g. in a holiday home), the secondary circuit temperature can drop below the minimum heat pump flow temperature. The heat pump compressor does not then run independently.

As a result, even with a mono mode heat pump design, an additional heat generator must always be included in the design; e.g. an instantaneous heating water heater.

If the heat pump **cannot** meet the heat demand in mono mode, then the heat pump must be operated in **mono energetic mode** (with instantaneous heating water heater) or in **dual mode** (with external heat generator). Otherwise you run the risk of the condenser icing up, causing significant damage to the heat pump.

Note

Depending on the type, the instantaneous heating water heater is either installed in the heat pump or available as an accessory. See chapter "Installation accessories".

Sizing is of particular relevance to heat pump systems that are to be operated in mono mode, since oversized equipment frequently incurs disproportionate system costs. Therefore avoid oversizing!

When sizing the heat pump, observe the following:

- Take into account supplements to the heat load of the building to cover power-OFF periods. [In Germany] the power supply utility may interrupt the power supply of heat pumps for up to 3 x 2 hours within a period of 24 hours. Observe additional individual arrangements for customers with special tariffs.
- The building inertia means that 2 hours of power-OFF time are not taken into consideration.

Note

The ON periods between 2 power-OFF times must be at least as long as the preceding power-OFF time.

Estimate of the heat load based on the heated area

The heated surface area (in m²) is multiplied by the following specific heat demand:

Passive house	10 W/m ²
Low energy house	40 W/m ²
New build (to EnEV)	50 W/m ²
House (built prior to 1995 with standard thermal insulation)	80 W/m ²
Older house (without thermal insulation)	120 W/m ²

Theoretical sizing with the power-OFF for 3 x 2 hours

Example:

For a new building with good thermal insulation (50 W/m²) and a heated area of 170 m²

- Estimated heat load: 8.4 kW
- Maximum power-OFF time 3 x 2 hours at a minimum outside temperature to EN 12831

24 h, therefore, result in a daily heat volume of:

- 8.4 kW · 24 h = 202 kWh

Design information (cont.)

To cover the maximum daily heat amount, only 18 h/day are available for heat pump operation on account of the power-OFF periods. The building inertia means that 2 hours of the period during which power is blocked are not taken into consideration.

■ 202 kWh / (18 + 2) h = 10.1 kW

In other words, the heat pump output would need to be increased by 20 % if power-OFF was to be applied 3 × 2 hours per day.

Frequently, power-OFF periods are only invoked if there is a need to do so. Please contact the customer's power supply utility to enquire about power-OFF periods.

Supplement for DHW heating in mono mode operation

Note

In dual mode operation of the heat pump, the heating output available is generally so high that this supplement does not need to be taken into consideration.

For a general residential building, a max. DHW demand of approx. 50 l per person per day at approx. 45 °C is assumed.

■ This demand represents an additional heat load of approx. 0.25 kW per person given a heat-up time of 8 h.

■ This supplement will only be taken into consideration if the sum total of the additional heat load exceeds 20 % of the heat load calculated to EN 12831.

	DHW demand at a DHW temperature of 45 °C in l per person/day	Specific available heat in Wh per person/day	Recommended heat load supplement for DHW heating ^{*9} in kW/person
Low demand	15 to 30	600 to 1200	0.08 to 0.15
Standard demand ^{*10}	30 to 60	1200 to 2400	0.15 to 0.30

or

	Reference temperature 45 °C in l per person/day	Specific available heat in Wh per person/day	Recommended heat load supplement for DHW heating ^{*9} in kW/person
Apartment (billing according to demand)	30	approx. 1200	approx. 0.150
Apartment (flat rate billing)	45	approx. 1800	approx. 0.225
Detached house ^{*10} (average demand)	50	approx. 2000	approx. 0.250

Supplement for setback mode

As the heat pump control unit is equipped with a temperature limiter for setback mode, the supplement for setback mode to EN 12831 can be ignored.

In addition, the control unit is equipped with start optimisation, which means that there is also no need for a supplement for heating up from setback mode.

Both functions must be enabled in the control unit. If any of the supplements are omitted because of the activated control unit functions then this must be documented when the system is handed over to the operator.

If, irrespective of the above mentioned control options, these supplements are nevertheless to be taken into account, the calculation should be made with reference to EN 12831.

Mono energetic operation

The heat pump system is supported by an additional electric heat source, an instantaneous heating water heater. The control unit switches the instantaneous heating water heater on, subject to the outside temperature (dual mode temperature) and heat load. The instantaneous heating water heater can be enabled separately for central heating and DHW heating.

Note

That part of the electric power drawn by the instantaneous heating water heater will generally **not** be charged at special tariffs.

Sizing of typical system configurations:

- Size the heating output of the heat pump to approx. 70 to 85 % of the maximum required building heat load to EN 12831.
- The heat pump covers approx. 95 % of the annual heat load.
- Blocking periods do not need to be taken into consideration.

Note

The reduced size of the heat pump, compared to mono mode operation, means that the runtime will increase. To compensate for this, increase the size of the heat source for brine/water heat pumps. As standard value for a geothermal probe system, the annual extraction rate must not exceed 100 kWh/m p.a.

Instantaneous heating water heater

In compact heat pump appliances the instantaneous heating water heater is factory-fitted. With the other heat pumps the instantaneous heating water heater is installed in the secondary circuit flow, sometimes inside the appliance, and is connected and fused via a separate mains connection.

The heat pump control unit regulates this function. The instantaneous heating water heater is enabled via parameters for heating operation and/or DHW heating. When enabled, the heat pump control unit activates stages 1, 2 or 3 of the instantaneous heating water heater, subject to the heat demand. As soon as the maximum flow temperature in the secondary circuit is reached, the heat pump control unit switches the instantaneous heating water heater off.

^{*9} With a DHW cylinder heat-up time of 8 h.

^{*10} Select a higher supplement if the actual DHW demand exceeds the stated values.

Design information (cont.)

Parameter "Stage at power-OFF" restricts the output stage of the instantaneous heating water heater for the duration of the power-OFF period.

To limit the total power consumption, the heat pump control unit stops the instantaneous heating water heater for a few seconds directly before the compressor starts. Each stage is subsequently started individually one after the other at intervals of 10 s.

If the instantaneous heating water heater is on and the differential between flow and return temperatures in the secondary circuit does not rise by at least 1 K within 24 h, the heat pump control unit displays a fault message.

Dual mode operation

External heat generator

The heat pump control unit enables dual mode operation of the heat pump with an external heat source, e.g. oil boiler.

The external heat source is hydraulically connected in such a way that the heat pump can also be used as a return temperature raising facility for the boiler. System separation is provided with either a low loss header or a heating water buffer cylinder.

For optimum heat pump operation, the external heat source must be integrated via a mixer into the heating water flow. Direct activation of this mixer by the heat pump control unit results in a quick response. If the outside temperature (long-term average) is below the dual mode temperature, the heat pump control unit starts the external heat source. In the case of direct heat demand from the consumers (e.g. for frost protection or if the heat pump is faulty), the external heat source is also started above the dual mode temperature.

The external heat source can also be enabled for DHW heating.

Note

The heat pump control unit does **not** contain any safety function for the external heat source. To prevent excessive temperatures in the heat pump flow and return in case of a fault, high limit safety cut-outs **must** be provided to stop the external heat source (switching threshold 70 °C).

9.6 Heat sources for brine/water heat pumps

Frost protection

To safeguard trouble-free heat pump operation, use antifreeze in the primary circuit. The antifreeze must protect against frost down to at least -15 °C and contain suitable anti-corrosion inhibitors. Ready-mixed solutions ensure an even distribution of concentrate throughout the primary circuit.

Recommendation:

For the primary circuit, use Viessmann "Tyfocor" heat transfer medium which is based on ethylene glycol (ready-mixed down to -16 °C, light green).

Where the following conditions are met, bioethanol-based antifreeze can be used with Viessmann brine/water heat pumps:

- Ready-mixed solution concentration: ≤ 30 % by vol.
- Recommendation: With corrosion inhibitors to improve residual alkalinity
- Please observe manufacturer usage instructions and safety data-sheets.

Note

When selecting the antifreeze, always observe the stipulations of the authorising body.

Operation of probe with water

The authorising body may prohibit operation with antifreeze:

- For example if there is a risk to the groundwater from escaping brine
- For example if there is a risk to groundwater horizons due to freeze/thaw cycles inside the borehole

In such cases, the probe can be operated with water. When doing so, the drilling company must size the probe so that frost-free operation is guaranteed at all times.

- The temperature in the primary circuit flow (heat pump brine inlet) can be cooled down to 5 K by the heat pump (depending on design). When sizing, therefore, ensure that the temperature in the primary circuit return (heat pump brine outlet) can remain above 0 °C with sufficient certainty.
- Despite operating the probe frost-free, temperatures < 0 °C on the refrigerant circuit side of the evaporator cannot be ruled out. To prevent damage to the evaporator caused by ice formation, a direct flow of water through the heat pump is not permitted. To operate the probe with water, an additional separating heat exchanger with intermediate circuit must be factored in (similar to the well circuit on water/water heat pumps).

Geothermal collector

The thermal properties of the upper layer of the earth, such as the volumetric thermal capacity and thermal conductivity, are largely dependent on the consistency and properties of the ground.

The wetter the soil, the higher the proportion of mineral constituents (quartz or feldspar) of the soil and the smaller the proportion of pores, the better the storage characteristics and thermal conductivity.

The specific extraction rate q_E for the ground lies between approx. 10 and 35 W/m².

Damp loamy soil	$q_E = 25\text{--}30 \text{ W/m}^2$
Ground with groundwater	$q_E = 30\text{--}35 \text{ W/m}^2$

These details enable the required ground area to be calculated subject to the heat load of the building and the refrigerating capacity \dot{Q}_K of the heat pump.

$$\dot{Q}_K = \dot{Q}_{WP} - P_{WP}$$

\dot{Q}_K is the difference between the heat pump heating output (\dot{Q}_{HP}) and its power consumption (P_{HP}).

Dry sandy soil	$q_E = 10\text{--}15 \text{ W/m}^2$
Damp sandy soil	$q_E = 15\text{--}20 \text{ W/m}^2$
Dry loamy soil	$q_E = 20\text{--}25 \text{ W/m}^2$

Design information (cont.)

Manifolds and headers

The manifold and the header should be installed so that they are accessible for future inspections, e.g. in their own distribution ducts outside the house or in the basement window duct.

Every pipe circuit should be able to be isolated individually on the flow and return side to enable the collector to be filled and vented.

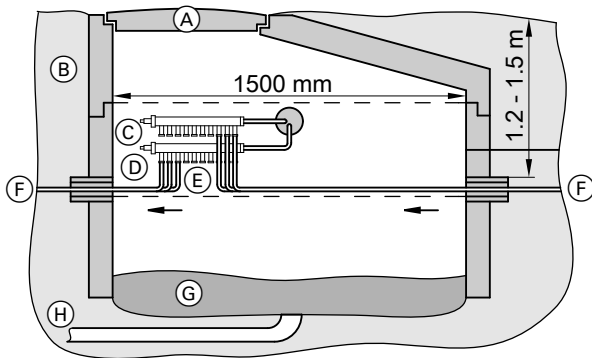

Example of a common duct

- (A) Access point \varnothing 600 mm
- (B) Concrete rings
- (C) Primary flow
- (D) Primary return
- (E) Brine distributor
- (F) Collector pipes
- (G) Crushed stone
- (H) Drainage

All pipes, profiles etc. must be made from corrosion-resistant materials. Flow and return lines transport cold brine (brine temperature $<$ cellar temperature). For that reason, all pipes inside the house and the wall outlets (even inside the wall structure) must be thermally insulated and vapour diffusion-proof to prevent the formation of condensation and subsequent damage from moisture. Alternatively, a drain can be installed to remove condensate. Practical experience has shown that a prepared brine mixture is satisfactory for filling the system.

Pipework should be routed on the outside of the building with a slight slope to prevent ingress of water during heavy rain. A good drainage system will ensure that the rainwater drains away.

The use of approved wall outlets (e.g. Doyma) is required if the site makes specific demands regarding pressing water.

Rough sizing

Basis for sizing is the refrigerating capacity \dot{Q}_K of the heat pump at **operating point B0/W35**.

Required area $F_E = \dot{Q}_K / \dot{q}_E$ (average extraction rate subject to ground conditions).

Required number of pipe circuits @ 100 m length subject to F_E and the pipe dimension:

- With PE 20 \times 2.0:
Pipe circuits @ 100 m length = $F_E \cdot 3/100$
- With PE 25 \times 2.3:
Pipe circuits @ 100 m length = $F_E \cdot 2/100$
- With PE 32 \times 3.0 (2.9):
Pipe circuits @ 100 m length = $F_E \cdot 1.5/100$

The detailed design depends on the ground structure and can only be determined following a local inspection.

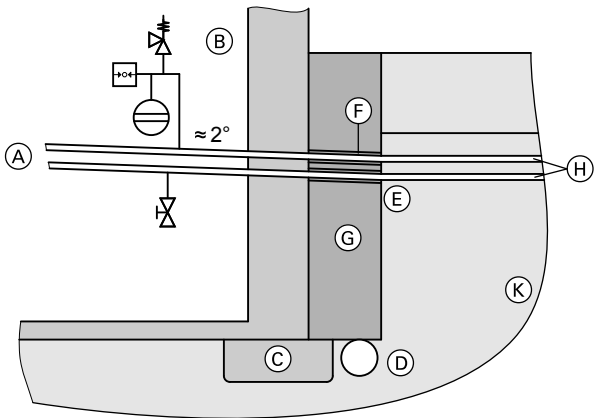

Example of a wall outlet

- (A) To the heat pump
- (B) Building
- (C) Foundations
- (D) Drainage
- (E) Seal
- (F) Pipe liner
- (G) Crushed stone
- (H) PE 32 \times 3.0 (2.9)
- (K) Ground

Design information (cont.)

Required brine manifolds and pipe circuits for $\dot{q}_E = 25 \text{ W/m}^2$

Assumed distances between pipes for a length of 100 m:

PE 25 x 2.3 approx. 0.50 m (2 m pipe/m²)

PE 32 x 2.9 approx. 0.70 m (1.5 m pipe/m²)

Approximate sizing for 100 m length

Vitocal	\dot{Q}_K	F_E (rounded) m ²	PE 25 x 2.3		PE 32 x 2.9	
			Pipe circuits	Brine manifold Part no.	Pipe circuits	Brine manifold Part no.
	kW					
200-G						
BWC 201.A06	4.5	180	4	1 x ZK01287	3	1 x ZK01289
BWC 201.A08	6.1	244	5	1 x ZK01286 1 x ZK01285	4	1 x ZK01290
BWC 201.A10	7.7	308	6	2 x ZK01286	5	1 x ZK01289 1 x ZK01288
BWC 201.A13	10.4	416	8	2 x ZK01287	6	2 x ZK01289
BWC 201.A17	13.7	548	11	2 x ZK01287 1 x ZK01286	8	2 x ZK01290
300-G, single stage						
BW, BWC 301.B06	4.6	184	4	1 x ZK01287	3	1 x ZK01289
BW, BWC 301.B08	6.2	248	5	1 x ZK01286 1 x ZK01285	4	1 x ZK01290
BW, BWC 301.B10	8.5	340	7	1 x ZK01286 1 x ZK01287	6	1 x ZK01290 1 x ZK01288
BW, BWC 301.B13	10.6	424	8	2 x ZK01287	6	2 x ZK01289
BW, BWC 301.B17	13.9	556	12	3 x ZK01287	9	3 x ZK01289
BW 301.A21	17.0	700	14	2 x ZK01287 2 x ZK01286	11	4 x ZK01289
BW 301.A29	23.3	940	19	4 x ZK01287 1 x ZK01286	14	3 x ZK01290 2 x ZK01288
BW 301.A45	34.2	1370	27	On site	21	On site
300-G, two-stage						
BW+BWS 301.B06	9.2	386	8	2 x ZK01287	6	2 x ZK01289
BW+BWS 301.B08	12.4	496	10	2 x ZK01287 1 x ZK01285	8	2 x ZK01290
BW+BWS 301.B10	16.8	672	14	3 x ZK01287 1 x ZK01285	10	2 x ZK01290 1 x ZK01288
BW+BWS 301.B13	21.2	848	17	5 x ZK01286 1 x ZK01285	13	1 x ZK01290 3 x ZK01289
BW+BWS 301.B17	27.8	1112	23	On site	17	5 x ZK01289 1 x ZK01288
BW+BWS 301.A21	34.0	1360	27	On site	20	5 x ZK01290
BW+BWS 301.A29	46.6	1870	37	On site	28	On site
BW+BWS 301.A45	68.4	2740	55	On site	41	On site
350-G, single stage						
BW 351.B20	16.4	656	14	3 x ZK01287 1 x ZK01285	10	2 x ZK01290 1 x ZK01288
BW 351.B27	23.0	920	19	4 x ZK01287 1 x ZK01286	14	3 x ZK01290 1 x ZK01288
BW 351.B33	26.3	1052	21	On site	16	4 x ZK01290
BW 351.B42	33.6	1344	27	On site	21	On site
350-G, two-stage						
BW+BWS 351.B20	32.8	1312	27	On site	20	5 x ZK01290
BW+BWS 351.B27	46.0	1840	37	On site	28	On site
BW+BWS 351.B33	52.6	2104	42	On site	32	On site
BW+BWS 351.B42	67.2	2688	54	On site	41	On site
222-G						
BWT-M 221.B06	4.5	180	4	1 x ZK01287	3	1 x ZK01289
BWT-M 221.B08	6.1	244	5	1 x ZK01286 1 x ZK01285	4	1 x ZK01290
BWT-M 221.B10	8.3	332	7	2 x ZK01286	5	1 x ZK01289 1 x ZK01288

Design information (cont.)

Vitocal	\dot{Q}_K	F_E	PE 25 x 2.3		PE 32 x 2.9	
		(rounded)	Pipe circuits	Brine manifold	Pipe circuits	Brine manifold
	kW	m ²		Part no.		Part no.
333-G						
BWT 331.C06	6.6 ^{*11}	264	5	1 x ZK01286 1 x ZK01285	4	1 x ZK01290
BWT 331.C12	8.55 ^{*11}	342	7	1 x ZK01286 1 x ZK01287	6	2 x ZK01289

Note

Up to 10 brine circuits can be connected in series to a single flow or return; up to 20 brine circuits can be connected in a parallel circuit. The brine manifolds and geothermal collector circuits must be designed and sized by a qualified contractor.

Example calculations for sizing the heat source

Selection of the heat pump

Building heat load (net heat load)	4.8 kW
DHW heating supplement for a 3-person household	0.75 kW (see chapter "DHW heating supplement": 0.75 kW < 20 % of building heat load)
Power-OFF periods	3 x 2 h/d (only 4 h are taken into account, see chapter "Mono mode operation")
Total heat load of the building	5.76 kW
System temperature (at min. outside temp. -14 °C)	45/40 °C
Heat pump operating point	B0/W35

The heat pump with a heating output of 5.9 kW (incl. supplement for power-OFF periods, excl. DHW heating), and a cooling capacity of $\dot{Q}_K = 4.7$ kW corresponds to the required output.

Sizing the geothermal collector

- Average specific extraction rate:
 $\dot{q}_E = 25$ W/m²
- $\dot{Q}_K = 4.7$ kW
- $F_E = \dot{Q}_K / \dot{q}_E = 4700$ W/25 W/m² = 188 m²
- The number X of required pipe circuits (PE pipe 25 x 2.3) @ 100 m length results from:
 $X = F_E \cdot 2 / 100 = 200$ m² · 2 m/m²/100 m = 4
- **Selected:** Four pipe circuits @ 100 m length (Ø 25 mm x 2.3 mm with 0.327 l/m)

Required amount of heat transfer medium (V_R)

- Take the content of the geothermal collector including all inlet pipes, plus the volume of fittings and the heat pump into consideration.
 - Provide distributors corresponding to the number of pipe circuits.
 - The low cooling capacity and the connected length mean that a supply line of PE 25 x 2.3 is sufficient.
 - Supply line: 10 m (2 x 5 m) with PE 32 x 3.0 (2.9)
- $$V_R = \text{no. of pipe circuits} \times 100 \text{ m} \times \text{pipeline volume} + \text{supply line length} \times \text{pipeline volume}$$
- $$= 4 \times 100 \text{ m} \times 0.327 \text{ l/m} + 10 \text{ m} \times 0.531 \text{ l/m}$$
- $$= 130.8 \text{ litres} + 5.31 \text{ litres}$$
- $$= 136 \text{ litres}$$

Selected: 200 litres (incl. heat transfer medium in the fittings and the heat pump).

Geothermal collector pressure drop

- Flow rate, heat pumps with 5.9 kW: 860 l/h
- Flow rate per pipe circuit = (860 l/h)/(4 circuits per 100 m) = 215 l/h per pipe circuit
- $\Delta p = R$ value x pipe length

R value (pressure drop) for PE 25 x 2.3 and 32 x 3.0 (2.9) (see tables "Pressure drop" for the pipelines):

- At 215 l/h ≈ 59 Pa/m
- At 860 l/h = 176 Pa/m

$$\Delta p_{\text{Pipe circuit}} = 59 \text{ Pa/m} \times 100 \text{ m} = 5900 \text{ Pa}$$

$$\Delta p_{\text{Supply line}} = 176 \text{ Pa/m} \times 10 \text{ m} = 1760 \text{ Pa}$$

$$\Delta p_{\text{Permissible}} = 66000 \text{ Pa} = 660 \text{ mbar (residual head at minimum flow rate)}$$

$$\Delta p = \Delta p_{\text{Pipe circuit}} + \Delta p_{\text{Supply line}} = 5900 \text{ Pa} + 1760 \text{ Pa} = 7670 \text{ Pa} \approx 77 \text{ mbar}$$

Result:

$\Delta p = \Delta p_{\text{Pipe circuit}} + \Delta p_{\text{Supply line}}$ does not exceed the value for $\Delta p_{\text{Permissible}}$, so the intended geothermal collector can be operated with a heat pump with 5.9 kW rated heating output.

*11 For the output-controlled Vitocal 333-G, the maximum cooling capacity at B0/W35 was used as a basis for assessment. Depending on the building heat load in the individual system design, the assumed cooling capacity may be lower.

Geothermal probe

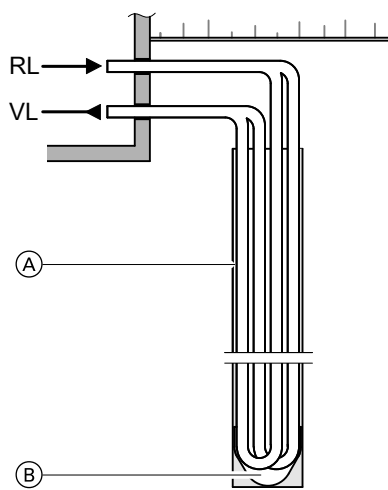

- RL Primary circuit return
- VL Primary circuit flow
- (A) Bentonite-cement suspension
- (B) Protective cap

On smaller plots and when retrofitting existing buildings, geothermal probes are an alternative to geothermal collectors. Below we consider the double U-shaped pipe probe.

One version would be 2 double U-shaped pipe loops made from plastic in one borehole. All cavities and spaces between the pipes and the ground are filled with a highly thermoconductive material (bentonite, for example).

Note

Prior to applying any thermal load to the geothermal probe, we recommend allowing the backfill material to set for 1 to 2 months. This improves the long-term stability of the geothermal probe and reduces the risk of frost damage (formation of cracks).

We recommend the following spacing between 2 geothermal probes:

- Up to 50 m deep: min. 5 m
- Up to 100 m deep: min. 6 m

The geothermal probes are installed either by drilling or by ramming, subject to their design. For these kinds of systems, local water authorities may have to be notified of the plan in advance and a permit obtained.

Possible specific extraction rates q_E for double U-shaped pipe probes (to VDI 4640 Part 2)

Subsoil	Specific extraction rate q_E in W/m
Standard values	
Poor subsoil (dry sediment) ($\lambda < 1.5 \text{ W}/(\text{m} \times \text{K})$)	20
Normal solid rock subsoil and water-saturated sediment ($1.5 \leq \lambda \leq 3.0 \text{ W}/(\text{m} \times \text{K})$)	50
Solid rock with high thermal conductivity ($\lambda > 3.0 \text{ W}/(\text{m} \times \text{K})$)	70
Individual rocks	
Gravel, sand (dry)	< 20
Gravel, sand (aquiferous)	55-65
Clay, loam (damp)	30-40
Limestone (solid)	45-60
Sandstone	55-65
Acidic magmatite (e.g. granite)	55-70
Basic magmatite (e.g. basalt)	35-55
Gneiss	60-70

Rough sizing

The basis for sizing is the cooling capacity \dot{Q}_K of the heat pump at operating point **B0/W35**.

Required probe length $l = \dot{Q}_K / \dot{q}_E$ (\dot{q}_E = average extraction rate subject to ground conditions).

The precise sizing depends on the ground structure and the water-carrying ground strata, and can only be determined following a local inspection by the drilling contractor.

Note

Reducing the number of drilled holes in favour of probe depth increases the pressure drop to be overcome and the required pump rate.

Information regarding dual mode parallel and mono energetic operation

In case of dual mode parallel and mono energetic operation, take account of the higher heat source load (see "Sizing"). As a guide, a geothermal probe system should not exceed an annual extraction rate of 100 kWh/m · p.a.

Required geothermal probes and brine manifolds for $\dot{q}_E = 50 \text{ W/m}$

Approximate sizing of geothermal probe as per VDI 4640 for 2000 hours run

Vitocal	\dot{Q}_K kW	PE 32 x 2.9		
		Total pipe length m	Geothermal probes Length in m	Brine manifold Part no.
200-G				
BWC 201.A06	4.5	90	1 x 90	1 x ZK01288
BWC 201.A08	6.1	122	1 x 122 or 2 x 66	1 x ZK01290
BWC 201.A10	7.7	154	2 x 77	1 x ZK01290
BWC 201.A13	10.4	208	2 x 104 or 3 x 70	2 x ZK01289
BWC 201.A17	13.7	274	3 x 92	2 x ZK01289

Design information (cont.)

Vitocal	\dot{Q}_K kW	PE 32 x 2.9		Brine manifold Part no.
		Total pipe length m	Geothermal probes Length in m	
300-G single stage				
BW, BWC 301.B06	4.6	92	1 x 92	1 x ZK01288
BW, BWC 301.B08	6.2	124	1 x 124 or 2 x 62	1 x ZK01290
BW, BWC 301.B10	8.5	170	2 x 85	1 x ZK01290
BW, BWC 301.B13	10.6	212	2 x 106 or 3 x 71	2 x ZK01289
BW, BWC 301.B17	13.9	278	3 x 93	2 x ZK01289
BW 301.A21	17.0	340	3 x 114 or 4 x 85	4 x ZK01290
BW 301.A29	23.3	466	5 x 94	2 x ZK01290 1 x ZK01288
BW 301.A45	34.2	684	7 x 98	3 x ZK01290 1 x ZK01288
300-G, two-stage				
BW+BWS 301.B06	9.2	184	2 x 92	1 x ZK01290
BW+BWS 301.B08	12.4	248	3 x 83	2 x ZK01289
BW+BWS 301.B10	16.8	336	4 x 84	2 x ZK01 290
BW+BWS 301.B13	21.2	424	5 x 85	2 x ZK01290 1 x ZK01288
BW+BWS 301.B17	27.8	556	6 x 93	3 x ZK01290
BW+BWS 301.A21	34.0	680	7 x 98	3 x ZK01290 2 x ZK01288
BW+BWS 301.A29	46.6	932	10 x 94	5 x ZK01290
BW+BWS 301.A45	68.4	1368	14 x 98	On site
350-G single stage				
BW 351.B20	16.4	328	3 x 110 or 4 x 82	2 x ZK01290
BW 351.B27	23.0	460	5 x 92	2 x ZK01290 1 x ZK01288
BW 351.B33	26.3	526	6 x 88	3 x ZK01290
BW 351.B42	33.6	672	7 x 97	3 x ZK01290 1 x ZK01288
350-G, two-stage				
BW+BWS 351.B20	32.8	656	7 x 94	3 x ZK01290 1 x ZK01288
BW+BWS 351.B27	46.0	920	10 x 92	5 x ZK01290
BW+BWS 351.B33	52.6	1052	11 x 96	On site
BW+BWS 351.B42	67.2	1344	14 x 97	On site
222-G				
BWT-M 221.B06	4.5	90	1 x 90	1 x ZK01288
BWT-M 221.B08	6.1	122	1 x 122 or 2 x 61	1 x ZK01290
BWT-M 221.B10	8.3	166	2 x 83	1 x ZK01290
333-G				
BWT 331.C06	6.6 ^{*11}	132	2 x 66	1 x ZK01290
BWT 331.C12	8.55 ^{*11}	171	2 x 86	1 x ZK01290

Brine manifold for 2-stage heat pump (BW+BWS)

The brine manifold for geothermal probes must be designed and sized by a qualified contractor.

Example calculations for sizing the heat source

Selection of the heat pump

Building heat load (net heat load)	4.8 kW
DHW heating supplement for a 3-person household	0.75 kW (see chapter "DHW heating supplement": 0.75 kW < 20 % of building heat load)
Power-OFF periods	3 x 2 h/d (only 4 h are taken into account, see chapter "Mono mode operation")
Total heat load of the building	5.76 kW
System temperature (at min. outside temp. -14 °C)	45/40 °C
Heat pump operating point	B0/W35

The heat pump with a heating output of 5.9 kW (incl. supplement for power-OFF periods, excl. DHW heating), and a cooling capacity of $\dot{Q}_K = 4.7$ kW corresponds to the required output.

^{*11} For the output-controlled Vitocal 333-G, the maximum cooling capacity at B0/W35 was used as a basis for assessment. Depending on the building heat load in the individual system design, the assumed cooling capacity may be lower.

Design information (cont.)

Sizing the geothermal probe as double U-pipe

- Average extraction rate:
 $\dot{q}_E = 50 \text{ W/m probe length}$
- $\dot{Q}_K = 4.7 \text{ kW}$
- Probe length $L = \dot{Q}_K / \dot{q}_E = 4700 \text{ W} / 50 \text{ W/m} = 94 \text{ m} \approx 100 \text{ m}$
- **Selected** pipe for the probe: PE 32 × 3.0 (2.9) with 0.531 l/m

Required amount of heat transfer medium (V_R)

- Take the content of the geothermal probe including all inlet pipes, plus the volume of fittings and the heat pump into consideration.
- Provide distributors when number of probes used is > 1 . Size the supply line larger than the pipe circuits; we recommend PE 32 to PE 63.
- Geothermal probe as double-U pipe.
 Supply line: 10 m (2 × 5 m) with PE 32 × 3.0 (2.9)
 $V_R = 2 \times \text{probe length } L \times 2 \times \text{pipeline volume} + \text{supply line length} \times \text{pipeline volume}$
 $= 2 \times 100 \text{ m} \times 2 \times 0.531 \text{ l/m} + 10 \text{ m} \times 0.531 \text{ l/m}$
 $= 217.7 \text{ l}$

Selected: 220 litres (incl. heat transfer medium in the fittings and the heat pump).

Pressure drop of the geothermal probe

- Heat transfer medium: Tyfocor
- Flow rate, heat pump with 5.9 kW: 860 l/h

- Flow rate per U- pipe: 860 l/h: 2 = 430 l/h
- $\Delta p = R \text{ value} \times \text{pipe length}$

R value (pressure drop) for PE 32 × 3.0 (2.9) (see tables "Pressure drop" for the pipelines):

- At 430 l/h $\approx 44 \text{ Pa/m}$
- At 860 l/h = 176 Pa/m

$$\begin{aligned} \Delta p_{\text{Double-U pipe probe}} &= 44 \text{ Pa/m} \times 2 \times 100 \text{ m} = 8800 \text{ Pa} \\ \Delta p_{\text{Supply line}} &= 176 \text{ Pa/m} \times 10 \text{ m} = 1760 \text{ Pa} \\ \Delta p_{\text{Permissible}} &= 66000 \text{ Pa} = 660 \text{ mbar (max. ext. pressure drop, primary side)} \\ \Delta p_{\text{Double-U pipe probe}} + \Delta p_{\text{Supply line}} &= 8800 \text{ Pa} + 1760 \text{ Pa} \\ &= 10560 \text{ Pa} \\ &\approx 106 \text{ mbar} \end{aligned}$$

Result:

$\Delta p = \Delta p_{\text{Double-U pipe probe}} + \Delta p_{\text{Supply line}}$ does not exceed the value for $\Delta p_{\text{Permissible}}$, so the intended geothermal collector can be operated with a heat pump with 5.9 kW rated heating output.

Expansion vessel for primary circuit

An expansion vessel with a capacity of 25 l is sufficient up to a supply line length of 20 m and up to a size of PE 40.

Detailed calculations are required for greater lengths.

V_A = total system volume (brine) in litres

V_N = rated volume of the expansion vessel in litres

V_Z = increase in volume during system heating, in litres

$$V_Z = V_A \times \beta \times \Delta t$$

β = expansion factor (β for Tyfocor 35 % = 0.0004)

Δt = temperature differential primary circuit (–5 to +20 °C) = 25 K

V_V = safety hydraulic seal (heat transfer medium Tyfocor) in litres

$= V_A \times (\text{hydraulic seal: } 0.005)$, at least 3 l (to DIN 4807)

p_e = permiss. terminal pressure in bar

$$p_e = p_{si} - 0.1 \times p_{si}$$

$$= 0.9 \times p_{si}$$

p_{si} = safety valve discharge pressure = 3 bar

$$V_N = (V_Z + V_V) \times (p_e + 1) / (p_e - p_{st})$$

p_{st} = nitrogen pre-charge pressure = 1.5 bar

Selected: 3 l

$$V_N = \frac{1.3 \text{ litres} + 3.0 \text{ litres}}{2.7 \text{ bar} - 1.5 \text{ bar}} \cdot (2.7 \text{ bar} + 1) = 13.25 \text{ litres}$$

Expansion vessel capacity for geothermal probes

V_A = geothermal collector capacity incl. supply line + heat pump capacity = 220 l

$$V_Z = V_A \times \beta \times \Delta t = 220 \text{ l} \times 0.0004 \text{ 1/K} \times 25 \text{ K} = 2.2 \text{ l}$$

$$V_V = V_A \times 0.005 = 220 \text{ l} \times 0.005 = 1.1 \text{ l}$$

Selected: 3 l

$$V_N = \frac{2.2 \text{ litres} + 3.0 \text{ litres}}{2.7 \text{ bar} - 1.5 \text{ bar}} \cdot (2.5 \text{ bar} + 1) = 15.17 \text{ litres}$$

Note

The brine expansion vessels are delivered with a pre-charge pressure of 4.5 bar (0.45 Pa). The pre-charge pressure must be adjusted to the required pressure in the primary circuit of 1.5 bar (0.15 Pa).

Expansion vessel capacity for geothermal collector

V_A = geothermal collector capacity incl. supply line + heat pump capacity = 130 l

$$V_Z = V_A \times \beta \times \Delta t = 130 \text{ l} \times 0.0004 \text{ 1/K} \times 25 \text{ K} = 1.3 \text{ l}$$

$$V_V = V_A \times 0.005 = 130 \text{ l} \times 0.005 = 0.65 \text{ l}$$

Pipework, primary circuit

Pressure drop in PE pipes, PN 10 with Tyfocor

R value (resistance value):

- R value = pressure drop/m line
- The specified R values refer to Tyfocor heat transfer medium:
 - Kinematic viscosity = 4.0 mm²/s
 - Density = 1050 kg/m³

Grey laminar flow

White turbulent flow

Flow rate in l/h	R-values in Pa/m for PE pipe		
	20 × 2.0 mm	25 × 2.3 mm	32 × 2.9 mm
100	77.4	27.5	–
120	92.9	32.9	–
140	108.4	38.4	–
160	123.9	43.9	–
180	139.4	49.4	–
200	154.9	54.9	–
220	170.3	60.4	–
240	185.8	65.9	–
260	201.3	71.4	–
280	216.8	76.9	–
300	232.3	82.3	31.2
320	247.8	87.8	33.3
340	263.3	93.3	35.4

Design information (cont.)

Flow rate in l/h	R-values in Pa/m for PE pipe			Flow rate in l/h	R-values in Pa/m for PE pipe		
	20 × 2.0 mm	25 × 2.3 mm	32 × 2.9 mm		20 × 2.0 mm	25 × 2.3 mm	32 × 2.9 mm
360	278.7	98.8	37.5	2160	–	–	880.2
380	294.2	104.3	39.5	2200	–	–	909.0
400	309.7	109.8	41.6	2240	–	–	938.1
420	325.2	115.3	43.7	2280	–	–	967.6
440	554.6	120.8	45.8	2320	–	–	997.5
460	599.5	126.3	47.9	2360	–	–	1027.8
480	645.8	131.7	49.9	2400	–	–	1058.5
500	693.7	137.2	52.0	2440	–	–	1089.5
520	742.9	142.7	54.1	2480	–	–	1121.0
540	793.7	246.3	56.2	2520	–	–	1152.8
560	845.8	262.4	58.3	2560	–	–	1185.0
580	899.4	279.1	60.3	2600	–	–	1217.6
600	–	296.1	62.4	2640	–	–	1250.6
620	–	313.6	64.5	2680	–	–	1283.9
640	–	331.5	66.6	2720	–	–	1317.6
660	–	349.9	68.7	2760	–	–	1351.7
680	–	368.6	70.7	2800	–	–	1386.2
700	–	387.8	122.5	2840	–	–	1421.1
720	–	407.4	128.7	2880	–	–	1456.3
740	–	427.4	135.0	2920	–	–	1491.8
760	–	468.7	141.5	2960	–	–	1527.8
780	–	489.9	148.1	3000	–	–	1564.1
800	–	511.5	154.8				
820	–	533.5	161.6				
840	–	566.0	168.6				
860	–	578.8	175.7				
880	–	602.0	182.9				
900	–	625.6	190.2				
920	–	649.6	197.7				
940	–	674.0	205.3				
960	–	698.8	213.0				
980	–	723.9	220.8				
1000	–	749.4	228.7				
1020	–	775.3	236.8				
1040	–	801.6	245.0				
1060	–	828.3	253.3				
1080	–	855.3	261.7				
1100	–	–	270.2				
1120	–	–	278.9				
1140	–	–	287.7				
1160	–	–	296.6				
1180	–	–	305.6				
1200	–	–	314.7				
1240	–	–	333.3				
1280	–	–	352.3				
1320	–	–	371.8				
1360	–	–	391.7				
1400	–	–	412.1				
1440	–	–	433.0				
1480	–	–	454.2				
1520	–	–	475.9				
1560	–	–	498.1				
1600	–	–	520.6				
1640	–	–	543.6				
1680	–	–	567.0				
1720	–	–	590.9				
1760	–	–	615.1				
1800	–	–	639.8				
1840	–	–	664.9				
1880	–	–	690.4				
1920	–	–	716.3				
1960	–	–	742.6				
2000	–	–	769.3				
2040	–	–	796.4				
2080	–	–	824.0				
2120	–	–	851.9				

Flow rate in l/h	R-values in Pa/m for PE pipe		
	40 × 3.7 mm	50 × 4.6 mm	63 × 5.8 mm
1500	165.8	56.9	17.8
1600	209.6	61.7	25.3
2000	274.0	96.0	30.1
2100	305.5	102.8	34.0
2300	383.6	117.8	42.7
2400	389.1	128.8	45.2
2500	404.2	141.8	48.0
2700	479.5	163.7	56.2
3000	575.4	189.1	63.0
3200	675.6	216.5	69.9
3600	808.3	202.8	84.9
3900	952.2	315.1	102.8
4200	1082.3	356.2	121.9
5200	1589.2	530.2	161.7
5400	1712.5	569.9	187.7
5500	1787.9	596.0	191.8
6200	2274.2	739.8	227.4
6300	2340.0	771.3	239.8
7200	–	1000.1	316.5
7800	–	1257.7	367.2
9200	–	1568.7	493.2
9300	–	1596.1	509.6
12600	–	2794.8	956.3
15600	–	–	1315.2
18600	–	–	1808.4

Volumes in PE pipes, PN 10

External pipe Ø × wall thickness mm	DN	Volume per m pipe	
		l	
20 × 2.0	15		0.201
25 × 2.3	20		0.327
32 × 3.0 (2.9)	25		0.531
40 × 2.3	32		0.984
40 × 3.7	32		0.835
50 × 2.9	40		1.595
50 × 4.6	40		1.308
63 × 5.8	50		2.070
63 × 3.6	50		2.445



Design information (cont.)

Percentage supplements to pump output for operation with Tyfocor

Note

Circulation pump curves, see chapter "Primary pump".

Design flow rate

$$\dot{Q}_A = \dot{Q}_{\text{water}} + f_Q \text{ (in \%)}$$

Design delivery head

$$H_A = H_{\text{water}} + f_H \text{ (in \%)}$$

The pump must be selected using the increased pump rate details

\dot{Q}_A and H_A .

Note

The loading only includes the correction for the circulation pumps. Corrections for the system curve and system data must be determined with the help of technical literature and information provided by the valve manufacturer.

Viessmann heat transfer medium "Tyfocor" (ready mixed medium for temperatures down to $-16\text{ }^\circ\text{C}$) has an ethylene glycol volume fraction of 30 %.

Volume ratio ethylene glycol	%	25	30	35	40	45	50
At operating temperature 0 °C							
- f_Q	%	7	8	10	12	14	17
- f_H	%	5	6	7	8	9	10
At operating temperature +2.5 °C							
- f_Q	%	7	8	9	11	13	16
- f_H	%	5	6	6	7	8	10
At operating temperature +7.5 °C							
- f_Q	%	6	7	8	9	11	13
- f_H	%	5	6	6	6	7	9

9.7 Heat source for water/water heat pumps

A conversion kit is required for operation as a water/water heat pump (see Viessmann pricelist).

Groundwater

Water/water heat pumps utilise the energy content of groundwater or cooling water.

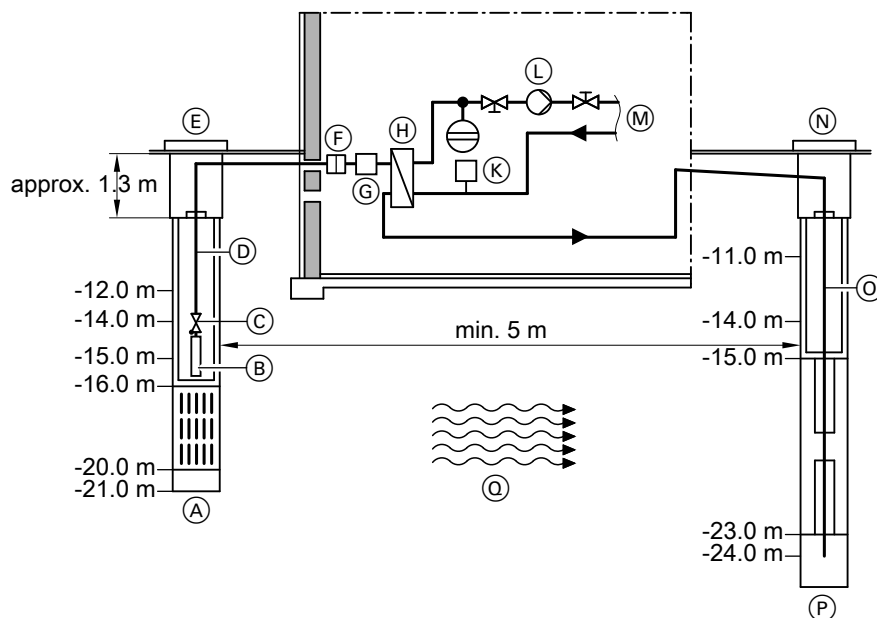

- (A) Delivery well
- (B) Well pump
- (C) Non-return valve
- (D) Supply pipe
- (E) Well shaft
- (F) Dirt trap (on site)
- (G) Flow switch, well circuit

- (H) Separating heat exchanger, intermediate circuit
- (K) Primary circuit frost stat
- (L) Primary pump (integrated subject to type)
- (M) To the heat pump
- (N) Well shaft
- (O) Pressure pipe
- (P) Return well
- (Q) Groundwater flow direction

5822541

Design information (cont.)

Water/water heat pumps achieve high performance factors. Groundwater offers an almost constant temperature all year round of 7 to 12 °C. Therefore the temperature level needs to be raised only a little higher (compared to other heat sources) in order for it to be able to be utilised for heating purposes.

Depending on the design, the heat pump cools the groundwater by up to 5 K, although its consistency remains otherwise unchanged.

- Due to the cost of pumping systems, we recommend that for detached houses and two-family houses the groundwater is pumped from a maximum depth of approx. 15 m (see the above diagram). For commercial or large scale systems, pumping from greater depths could still be viable.
- Maintain a distance of at least 5 m between the point of extraction (delivery well) and the point of re-entry (return well). Delivery and return wells must be located in the line of flow of the groundwater to prevent a "flow short circuit". Construct the return well so that the water exits below the groundwater level.

- Due to fluctuating water quality, we generally recommend system separation between wells and heat pump (see technical guide "Heat pump principles").
- The groundwater flow and return lines to/from the heat pump must be protected against frost and must fall towards the well.
- Recommendation: Use a dirt trap to protect the separating heat exchanger for the intermediate circuit.
- Two-stage heat pumps:
If the stage 1 and 2 heat pumps (type BW and BWS) are installed with different rated heating outputs, two primary pumps must be used due to the differing flow rates.

Note

The on-site primary pump for the 2nd stage cannot be connected to the heat pump control unit via a PWM signal. The settings must be performed on the primary pump's control unit.

Calculating the required groundwater volume

The required groundwater flow rate depends on the heat pump output and the rate of groundwater cooling.

For minimum flow rates, see the heat pump specification (e.g. minimum flow rate for Vitocal 300-G, type BW 301.B13 = 3.3 m³/h).

When sizing the primary pumps, please note that higher flow rates result in increased internal pressure drop.

Permits for a groundwater/water heat pump system

This project requires permission from the "local water authority" [check local regulations].

Where buildings must be connected to the public water system, the utilisation of the groundwater as a heat source for heat pumps must be authorised by your local authority [check local regulations].

Permits can be subject to certain stipulations.

Sizing the heat exchanger, primary intermediate circuit

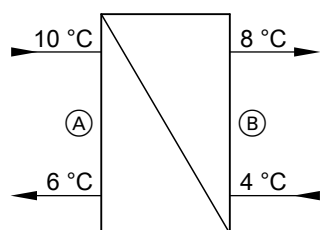

- (A) Water
- (B) Brine (antifreeze mixture)

Note

Fill the primary intermediate circuit with antifreeze mixture (brine, min. -5 °C).

The operational reliability of a water/water heat pump improves when it is used with a heat exchanger in the primary intermediate circuit. Subject to the correct sizing of the primary pump and the optimum layout of the primary intermediate circuit, the coefficient of performance of a water/water heat pump will be reduced by a maximum of 0.4.

We recommend the use of the threaded stainless steel plate heat exchanger from the Viessmann Vitoset pricelist (manufacturer: Tranter AG); see the following selection table.

Selection lists of plate heat exchangers (separating heat exchangers) for water/water heat pumps

Vitocal	Cooling capacity kW	Plate heat exchanger (threaded)	
		Type	Part no.
300-G, single stage			
BW, BWC 301.B06	6.4	GL-8PI x 16	7539287
BW, BWC 301.B08	8.8	GL-8PI x 20	7539288
BW, BWC 301.B10	11.6	GL-8PI x 28	7539291
BW, BWC 301.B13	14.5	GL-8PI x 32	7539289
BW, BWC 301.B17	19.2	GL-8PI x 42	7539292
BW 301.A21	23.7	GL-8PI x 42	7539292
BW 301.A29	31.4	GL-8PI x 52	7539293
BW 301.A45	48.9	GL-8PI x 74	7539296

Design information (cont.)

Vitocal	Cooling capacity kW	Plate heat exchanger (threaded) Type	Part no.
300-G, two-stage			
BW+BWS 301.B06	12.8	GL-8PI x 28	7539291
BW+BWS 301.B08	17.6	GL-8PI x 36	7539290
BW+BWS 301.B10	23.2	GL-8PI x 52	7539293
BW+BWS 301.B13	29.0	GL-8PI x 52	7539293
BW+BWS 301.B17	40.0	GL-8PI x 70	7539295
BW+BWS 301.A21	47.4	GL-8PI x 74	7539296
BW+BWS 301.A29	62.8	GC-16PI x 58	7539298
BW+BWS 301.A45	97.8	GC-16PI x 68	7539299
350-G, single stage			
BW 351.B20	21.1	GL-8PI x 42	7539292
BW 351.B27	29.3	GL-8PI x 52	7539293
BW 351.B33	35.7	GL-8PI x 70	7539295
BW 351.B42	43.8	GL-8PI x 74	7539296
350-G, two-stage			
BW+BWS 351.B20	42.2	GL-8PI x 74	7539296
BW+BWS 351.B27	58.6	GC-16PI x 58	7539298
BW+BWS 351.B33	71.4	GC-16PI x 58	7539298
BW+BWS 351.B42	87.6	GC-16PI x 68	7539299

Types BWC

Flow rate and pressure drop in the primary intermediate circuit are ensured by the integral circulation pumps as long as the following condition is met:

The maximum external pressure drop in the heat pump (see "Specification") must be lower than the total pressure drop in the primary intermediate circuit heat exchanger and pipework.

Coolant

If coolant from an industrial waste heat process is used as a heat source for a water/water heat pump, please observe the following:

- The water quality must comply with the limits applicable for copper-soldered or brazed stainless steel plate heat exchangers (see table in "Principles").
- If the water quality falls outside these limits, use a stainless steel heat exchanger in the primary intermediate circuit (see table on page 154). Sizing is carried out by the manufacturer of the heat exchanger.
- The available amount of water must satisfy the minimum flow rates of the primary side of the heat pump (see Specification).
- The maximum flow temperature (water inlet) for water/water heat pumps is 25 °C. At higher coolant temperatures, a low end controller is required on the primary side of the heat pump to limit the max. flow temperature (water inlet) to 25 °C. E.g. by adding cool return water.
Low end controller: Landis & Staefa GmbH, Siemens Building Technologies, for example

Note

The utilisation of coolant is also possible in conjunction with a brine/water heat pump. The max. flow temperature must then be limited as for the water/water heat pump to 25 °C.

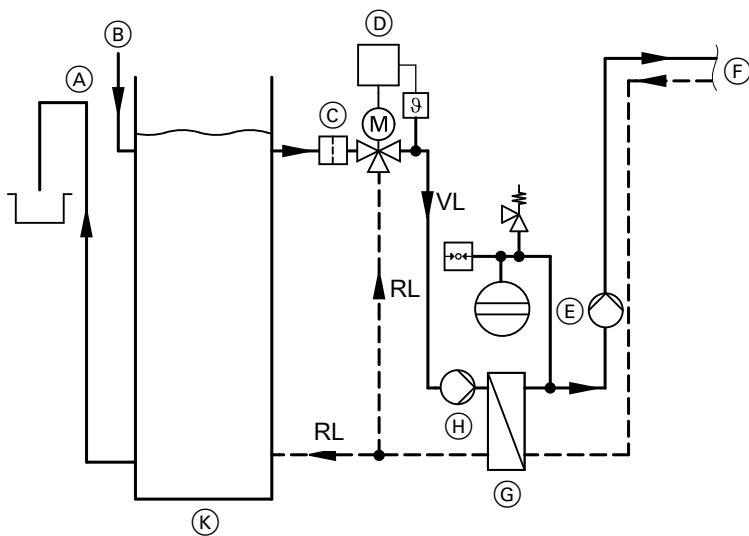

- (A) Overflow
- (B) Inlet
- (C) Dirt trap (on site)
- (D) Low end controller and valve (on site)
- (E) Primary pump
- (F) To the heat pump
- (G) Primary circuit heat exchanger (see page 154)
- (H) Circulation pump ($\hat{=}$ well pump)
- (K) Water container (min. 3000 l capacity, on site)

9.8 Heating circuit and heat distribution

Different heating water flow temperatures are required depending on the heating system design.

Heat pumps reach a maximum flow temperature of 65 °C.

To enable the mono mode operation of the heat pump, install a low temperature heating system with a heating water flow temperature of ≤ 60 °C.

The lower the selected maximum heating water flow temperature, the higher the seasonal performance factor of the heat pump.

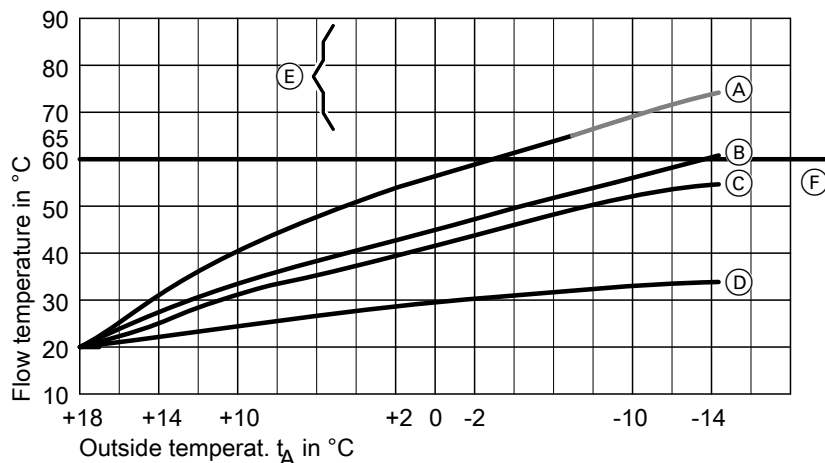

- (A) Max. heating water flow temperature = 75 °C
- (B) Max. heating water flow temperature = 60 °C
- (C) Max. heating water flow temperature = 55 °C, requirement for mono mode heat pump operation
- (D) Max. heating water flow temperature = 35 °C (ideal for mono mode heat pump operation)
- (E) Heating systems that have limited suitability for dual mode operation of the heat pump
- (F) Max. heat pump flow temperature, e.g. = 60 °C

9.9 Hydraulic conditions for the secondary circuit

Minimum flow rate and minimum system volume

For trouble-free operation, heat pumps require a **minimum flow rate** in the secondary circuit.

In order to ensure the minimum runtimes for the heat pump, a **minimum system volume** in the secondary circuit must also be considered. If the system volume is too small, the heat pump may switch on and off too frequently if heat consumption in the building is low (cycling).

There must be no means of shutting off the minimum system volume. The heating circuits that can be shut off via thermostatic valves must therefore not be included in the calculation.

Values for minimum flow rate and minimum system volume
 Values must be strictly observed: See tables on page 158.

In heat pumps with output control the heat transfer adjusts to the building's heat load, which enables reduced cyclical operation in the partial load range.

Even with these heat pumps, however, the minimum system volume must be available when the heat demand in the building is very low, e.g. towards the end of spring.

Systems with a heating water buffer cylinder connected in parallel

Heating water buffer cylinders connected in parallel to the heat pump ensure a sufficient minimum system volume in the secondary circuit. Hydraulic separation of the heating circuits also ensures the minimum flow rate of the heat pump, regardless of the hydraulic conditions in the heating circuits.

Benefits

- Hydraulic separation of the heat pump from the heating circuits ensures a constant flow rate through the heat pump.
 For example, if the heating circuit flow rate is reduced via thermostatic valves, the flow rate through the heat pump remains constant.
- The secondary pump can be sized smaller, due to the lower pressure drop to the heating water buffer cylinder.
- Heating circuits with mixer can be supplied with a different flow temperature to a heating circuit without mixer.
- Additional heat generators can be integrated into the system, e.g. solar central heating backup.
- Bridging power-OFF periods:
 Subject to the electricity tariff, heat pumps can be switched off at peak times by the power supply utility. The buffer cylinder supplies the heating circuits including during this power-OFF time.
- The large buffer volume is used to extend the runtime of the heat pump. This avoids frequently switching the heat pump on and off (cycles).

Implementation instructions

- When sizing the heating water buffer cylinder, note whether under-floor heating circuits and/or radiator heating circuits are connected.
- Due to the large volume of water and possible separate shut-off equipment for the heat generator, allow for a second or a larger expansion vessel.
- Set up the safety equipment for the system according to EN 12828.
- The volumetric flow rate of the secondary pump must be greater than that of the heating circuit pumps.
- In conjunction with an underfloor heating circuit, a temperature limiter must be installed to limit the maximum temperature of under-floor heating (part no. 7151728 or 7151729).

Sizing the heating water buffer cylinder for runtime optimisation

Note

With 2-stage heat pumps and heat pump cascades, the volume of the heating water buffer cylinder can be sized to match the output of the heat pump with the highest rated heating output, to achieve runtime optimisation.

$$V_{HP} = Q_{WP} \cdot (20 \text{ to } 25 \text{ litres})$$

Q_{WP} = Absolute rated heating output of the heat pump

V_{HP} = Heating water buffer cylinder volume in litres

Example:

Type BW 301.B10 with $Q_{WP} = 10.36 \text{ kW}$
 $V_{HP} = 10.36 \times 20 \text{ litres}$
 = 207 litre cylinder capacity

Selection: Vitocell 100-E with 200 litre cylinder capacity

Sizing the heating water buffer cylinder for bridging power-OFF periods

These versions are offered for heat distribution systems without additional cylinder mass (e.g. radiators, hot water air heaters). Storing 100 % of heating energy for the duration of the power-OFF periods is feasible, but not recommended, otherwise the cylinder volume required would be too great.

Example:

$\Phi_{HL} = 10 \text{ kW} = 10,000 \text{ W}$
 $t_{SZ} = 2 \text{ h (max. 3 x per day)}$
 $\Delta\vartheta = 10 \text{ K}$
 $c_P = 1.163 \text{ Wh/(kgK)}$ for water
 c_P spec. thermal capacity in kWh/(kg·K)
 Φ_{HL} Heat load of the building in kW
 t_{SZ} Blocking time in h
 V_{HP} Heating water buffer cylinder volume in l
 $\Delta\vartheta$ System cool-down in K

100 % sizing

(subject to the existing heating surfaces)

$$V_{HP} = \frac{\Phi_{HL} \cdot t_{SZ}}{c_P \cdot \Delta\vartheta}$$

$$V_{HP} = \frac{10000 \text{ W} \cdot 2 \text{ h}}{1.163 \frac{\text{Wh}}{\text{kg} \cdot \text{K}} \cdot 10 \text{ K}} = 1720 \text{ kg}$$

1720 kg water represent a cylinder capacity of 1720 l.

Selection: 2 Vitocell 100-E, each with 1000 litre cylinder capacity

Rough sizing

(subject to the utilisation of the delayed building heat loss)

$$V_{HP} = \Phi_{HL} \cdot (60 \text{ to } 80 \text{ l})$$

$$V_{HP} = 10 \cdot 60 \text{ l}$$

$V_{HP} = 600 \text{ l}$ cylinder capacity

Selection: 1 Vitocell 100-E with 750 l cylinder capacity

Systems with heating water buffer cylinder connected in series

In systems with a heating water buffer cylinder connected in series the required minimum system volume can be ensured. This type of heating water buffer cylinder is integrated into the secondary circuit return.

Benefits

- The large buffer volume is used to extend the runtime of the heat pump. This avoids frequently switching the heat pump on and off (cycles).
- Due to the high energy content, a heating water buffer cylinder always provides the required defrost energy for the heat pump.

Implementation instructions

- An overflow valve **must** be integrated in the heating circuit to ensure that the additional system volume is always available even in sealed unvented heating circuits.
The flow rate of the overflow valve must be selected to ensure the minimum flow rate of the heat pump.
- Set up the safety equipment for the system according to EN 12828.
- In conjunction with an underfloor heating circuit, a temperature limiter must be installed to limit the maximum temperature of underfloor heating (part no. 7151728 or 7151729).

Systems without heating water buffer cylinder

In systems without a heating water buffer cylinder, trouble-free operation of the heat pump is only ensured if the following conditions are met:

- The minimum flow rate and the minimum system volume of the heat pump are ensured at all times.
- To avoid any loss of comfort caused by blocking periods, set up the heat pump power supply without power-OFF.

Implementation instructions

Take the following measures to ensure that the minimum flow rate of the heat pump is always available even in sealed unvented heating circuits:

- Fit an overflow valve in the heating circuit.
The flow rate of the overflow valve must be selected to ensure the minimum flow rate of the heat pump.
- Keep parts of the heat distribution system open:
Observe the relevant national regulations and/or Energy Savings Ordinance. The consent of the system user is required.
- In conjunction with an underfloor heating circuit, a temperature limiter must be installed to limit the maximum temperature of underfloor heating (part no. 7151728 or 7151729).



9.10 Planning aids for the secondary circuit

The required minimum flow rate and the minimum system volume must always be guaranteed. The following tables give an overview of which components can be used to achieve this:

- Secondary circuit pipework
- Low loss header connected in parallel to the heat pump

- Heating water buffer cylinder connected in parallel to the heat pump
- Heating water buffer cylinder connected in series to the secondary circuit return

Design information (cont.)

Heat pump	Type	\dot{V}_{\min} in l/h	$\varnothing_{\text{pipes}}$	V_{\min} in l*12	Without buffer cylinder	Buffer cylinder (recommended minimum)		
								
Vitocal 200-G	BWC, BWC-M 201.A06	520	DN 25		Do not calculate the minimum system volume via the pipework.	Vitocell 100-E 46 l	Vitocell 100-E 200 l	Vitocell 100-E 200 l
	BWC, BWC-M 201.A08	660	DN 25		Do not calculate the minimum system volume via the pipework.	Vitocell 100-E 46 l	Vitocell 100-E 200 l	Vitocell 100-E 200 l
	BWC, BWC-M 201.A10	850	DN 25		Do not calculate the minimum system volume via the pipework.	Vitocell 100-E 46 l	Vitocell 100-E 200 l	Vitocell 100-E 200 l
	BWC 201.A13	1100	DN 32		Do not calculate the minimum system volume via the pipework.	Vitocell 100-E 200 l	Vitocell 100-E 200 l	Vitocell 100-E 200 l
	BWC 201.A17	1500	DN 32		Do not calculate the minimum system volume via the pipework.	Vitocell 100-E 200 l	Vitocell 100-E 400 l	Vitocell 100-E 400 l
Vitocal 300-G	BWC, BWC, BWS 301.B06	520	DN 25		Do not calculate the minimum system volume via the pipework.	Vitocell 100-E 46 l	Vitocell 100-E 200 l	Vitocell 100-E 200 l
	BWC, BWC, BWS 301.B08	680	DN 25		Do not calculate the minimum system volume via the pipework.	Vitocell 100-E 46 l	Vitocell 100-E 200 l	Vitocell 100-E 200 l
	BWC, BWC, BWS 301.B10	880	DN 25		Do not calculate the minimum system volume via the pipework.	Vitocell 100-E 46 l	Vitocell 100-E 200 l	Vitocell 100-E 200 l
	BWC, BWC, BWS 301.B13	1080	DN 32		Do not calculate the minimum system volume via the pipework.	Vitocell 100-E 200 l	Vitocell 100-E 200 l	Vitocell 100-E 200 l
	BWC, BWC, BWS 301.B17	1490	DN 32		Do not calculate the minimum system volume via the pipework.	Vitocell 100-E 200 l	Vitocell 100-E 400 l	Vitocell 100-E 400 l
	BWC, BWS 301.A21	1900	DN 40		Do not calculate the minimum system volume via the pipework.			
	BWC, BWS 301.A29	2550	DN 40		Do not calculate the minimum system volume via the pipework.			
	BWC, BWS 301.A45	3700	DN 40		Do not calculate the minimum system volume via the pipework.			
Vitocal 350-G	BW, BWS 351.B20	1500	DN 40		Do not calculate the minimum system volume via the pipework.	Individual sizing required		
	BW, BWS 351.B27	2050	DN 40		Do not calculate the minimum system volume via the pipework.			
	BW, BWS 351.B33	2400	DN 40		Do not calculate the minimum system volume via the pipework.			
	BW, BWS 351.B42	3000	DN 40		Do not calculate the minimum system volume via the pipework.			
Vitocal 222-G	BWT-M 221.B06	600	DN 25		Do not calculate the minimum system volume via the pipework.	Vitocell 100-E 46 l	Vitocell 100-E 200 l	Vitocell 100-E 200 l
	BWT-M 221.B08	710	DN 25		Do not calculate the minimum system volume via the pipework.	Vitocell 100-E 46 l	Vitocell 100-E 200 l	Vitocell 100-E 200 l
	BWT-M 221.B10	920	DN 25		Do not calculate the minimum system volume via the pipework.	Vitocell 100-E 46 l	Vitocell 100-E 200 l	Vitocell 100-E 200 l
Vitocal 333-G	BWT 331.C06	600	DN 25	13	X	Vitocell 100-E 46 l	Vitocell 100-E 200 l	Vitocell 100-E 200 l
	BWT 331.C12	720	DN 25	15	X	Vitocell 100-E 46 l	Vitocell 100-E 200 l	Vitocell 100-E 200 l

5822541

*12 Cannot be fitted with shut-off devices

Design information (cont.)

Heating water buffer cylinder in the heat pump return
(connected in series)

Icons:

X Possible

\dot{V}_{\min} Minimum flow rate, secondary circuit

$\varnothing_{\text{pipes}}$ Minimum diameter of pipes in secondary circuit

V_{\min} Minimum volume of the heating system



Underfloor heating circuit



Radiator heating circuit

Pipework volume

Pipe	Nominal diameter	Dimension x wall thickness in mm	Volume in l/m
Copper pipe	DN 25	28 x 1	0.53
	DN 32	35 x 1	0.84
	DN 40	42 x 1	1.23
	DN 50	54 x 2	2.04
	DN 60	64 x 2	2.83
Threaded pipes	1	33.7 x 3.25	0.58
	1 ¼	42.4 x 3.25	1.01
	1 ½	48.3 x 3.25	1.37
	2	60.3 x 3.65	2.21
Composite pipes	DN 25	32 x 3	0.53
	DN 32	40 x 3.5	0.86
	DN 40	50 x 4.0	1.39
	DN 50	63 x 6.0	2.04
Hydraulic connection lines	DN 32	40 x 3.7	0.84
	DN 40	50 x 4.6	1.31

Note

If the heat pump is also used for cooling, the heating water flow and heating water return must be thermally insulated with vapour diffusion-proof material.

9.11 Water quality and heat transfer medium

DHW

The appliances can be used with potable water up to 20 °dH (3.58 mol/m³). In case of higher hardness levels, a softening system for potable water is required on site to protect the integral plate heat exchanger.

Heating water

Unsuitable fill and top-up water increases the level of deposits and corrosion. This can lead to system damage. Observe VDI 2035 regarding quality and amount of heating water, including fill and top-up water.

- Flush the heating system thoroughly before filling.
- Only fill with water of potable quality.
- If the fill and top-up water has a water hardness greater than 16.8 °dH (3.0 mol/m³), it must be softened, e.g. using the small softening system for heating water: See the Vitoset pricelist.

Solar circuit heat transfer medium

- Fill the solar circuit only with Tyfocor LS heat transfer medium (frost protection down to -28 °C). Never dilute the heat transfer medium with water.
- Provide an expansion vessel for the solar circuit, sized in accordance with the details on page 176.
- Never use zinc-plated/galvanised pipes or components for the solar circuit.

Heat transfer medium, primary circuit (brine circuit)

- To ensure fault-free heat pump operation, the primary circuit may only be filled with an approved heat transfer medium: See 145.
- Provide an expansion vessel for the primary circuit, sized in accordance with the details on page 151.
- Never use zinc-plated/galvanised pipes for the primary circuit.

9.12 DHW heating

Function description regarding DHW heating

Compared to central heating, DHW heating makes fundamentally different demands, as almost identical amounts of heat must be provided all the year round at the same temperature level.

In the delivered condition, DHW heating by the heat pump takes priority over the heating circuits.

The heat pump control unit switches the DHW circulation pump OFF during cylinder heating to prevent cylinder heating from being impaired or extended.

The max. cylinder storage temperature is limited subject to the heat pump used and the individual system configuration. Storage temperatures above this limit are only possible with the assistance of a booster heater.

Booster heaters suitable for DHW reheating:

- External heat generator
- Instantaneous heating water heater (accessory)
- Immersion heater EHE (accessory)

Note

Only use the EHE immersion heater with soft to medium hard water up to 14 °dH (average hardness level, up to 2.5 mol/m³).

The integral load manager in the heat pump control unit decides which heat sources to use for DHW heating. Generally the external heat generator has priority over the electric heaters.

If one of the following criteria is met, the booster heaters begin cylinder heating:

- Cylinder temperature below 3 °C (frost protection).
- Heat pump supplies no heating output and actual temperature has fallen below set value at the top cylinder temperature sensor.

Note

The immersion heater in the DHW cylinder and the external heat generator stop as soon as the set value at the top temperature sensor is reached, minus a hysteresis of 1 K.

DHW heating should preferably take place during the night after 22:00 h. This has the following advantages:

- The heat pump heating output is available for central heating during the daytime.
- Better utilisation of economy (night) tariffs (if offered by the power supply utility).
- DHW cylinder heating and simultaneous drawing can be avoided. When using an external heat exchanger, the system may not always achieve the required draw-off temperatures because of the system design.

Connection on the DHW side

For connecting the DHW side, observe EN 806, DIN 1988 and DIN 4753 (CH: SVGW regulations). Observe other country-specific standards as applicable.

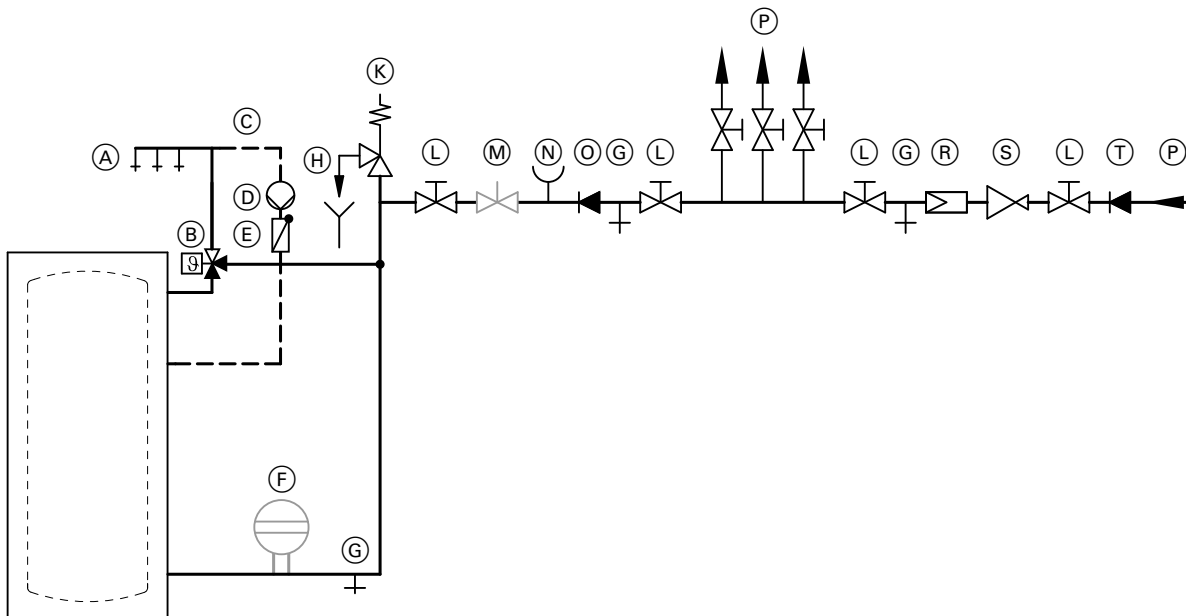

Example with Vitocell 100-V, type CVWA

- | | |
|---|--|
| (A) DHW | (G) Drain outlet |
| (B) Automatic thermostatic mixing valve | (H) Visible discharge pipe outlet point (tundish) |
| (C) DHW circulation pipe | (K) Safety valve |
| (D) DHW circulation pump | (L) Shut-off valve |
| (E) Spring-loaded check valve | (M) Flow regulating valve (installation recommended) |
| (F) Expansion vessel, suitable for drinking water | |

5822541

Design information (cont.)

- | | |
|-------------------------------|---|
| (N) Pressure gauge connection | (R) Drinking water filter |
| (O) Non-return valve | (S) Pressure reducer DIN 1988-200:2012-05 |
| (P) Cold water | (T) Non-return valve/pipe separator |

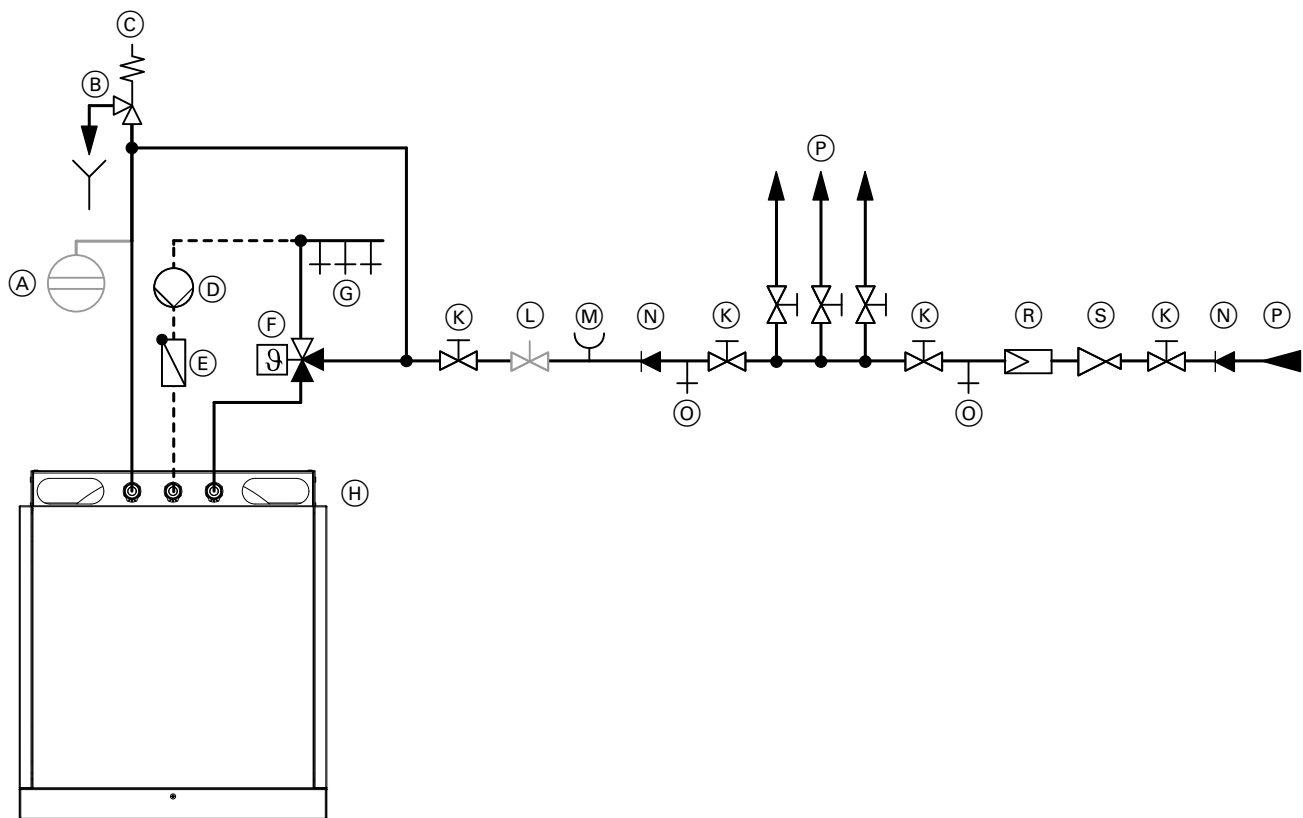

Example showing the Vitocal 333-G

- | | |
|---|---|
| (A) Expansion vessel, suitable for drinking water | (K) Shut-off valve |
| (B) Visible discharge pipe outlet point (tundish) | (L) Flow regulating valve |
| (C) Safety valve | (M) Pressure gauge connection |
| (D) DHW circulation pump | (N) Non-return valve/pipe separator |
| (E) Spring-loaded check valve | (O) Drain valve |
| (F) Automatic thermostatic mixing valve | (P) Cold water |
| (G) DHW | (R) Drinking water filter |
| (H) Heat pump terminal area (plan view) | (S) Pressure reducer DIN 1988-200:2012-05 |

Safety valve

Protect the DHW cylinder with a safety valve against unduly high pressure.

Recommendation: Install the safety valve higher than the top edge of the cylinder. This protects the valve against contamination, scaling and high temperatures. The DHW cylinder will also not need to be drained when working on the safety valve.

Automatic thermostatic mixing valve

With appliances that heat DHW to temperatures above 60 °C, an automatic thermostatic mixing valve must be installed in the DHW line as protection against scalding.

This also particularly applies when connecting solar thermal systems.

9.13 DHW cylinder selection

When selecting the DHW cylinder ensure that its indirect coil surface area is large enough for the purpose.
Approximate calculation of the coil surface area:

Minimum indirect coil surface area in m² ≈ heat pump output in kW x 0.3 m²/kW

Design information (cont.)

Recommendation:

- 4 person household:
DHW cylinder with 300 l capacity
- 5 to 8 person household:
DHW cylinder with 500 l capacity with additional immersion heater
or an instantaneous heating water heater in the secondary circuit
flow

Vitocal	Up to 4 occupants Vitocell 100-V, CVWA			Vitocell 100-B 300 l	Vitocell 300-B 300 l	Up to 8 occupants	
	300 l	390 l	500 l			Vitocell 100-B 500 l	Vitocell 300-B 500 l
200-G							
BWC 201.A06	X	X	X	X	X	X	X
BWC 201.A08	X	X	X	-	X	-	X
BWC 201.A10	X	X	X	-	X	-	X
BWC 201.A13	-	X	X	-	-	-	-
BWC 201.A17	-	X	X	-	-	-	-
300-G, single stage							
BW, BWC 301.B06	X	X	X	-	X	X	X
BW, BWC 301.B08	X	X	X	-	X	-	X
BW, BWC 301.B10	X	X	X	-	X	-	X
BW, BWC 301.B13	-	X	X	-	-	-	-
BW, BWC 301.B17	-	X	X	-	-	-	-
300-G, two-stage							
DHW heating with stage 1 or stage 2							
BW+BWS 301.B06	X	X	X	X	X	X	X
BW+BWS 301.B08	X	X	X	-	X	-	X
BW+BWS 301.B10	X	X	X	-	X	-	X
BW+BWS 301.B13	-	X	X	-	-	-	-
BW+BWS 301.B17	-	X	X	-	-	-	-

Further specifications for DHW cylinders

See "Installation accessories" chapter and separate technical guides.

Hydraulic connection, DHW cylinder

DHW cylinder with internal indirect coils

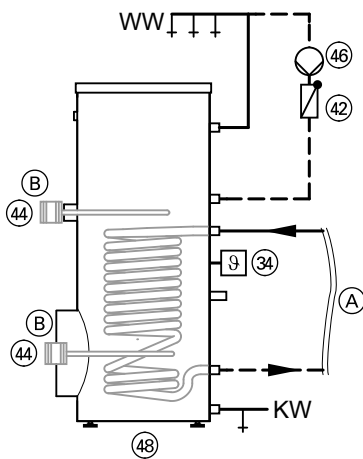

Vitocell 100-V, type CVWA

- (A) Heat pump connection
- (B) Alternative
- KW Cold water
- WW DHW

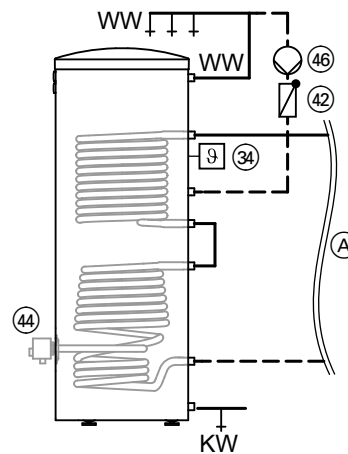

Vitocell 100-B

- (A) Heat pump connection
- KW Cold water
- WW Domestic hot water

Equipment required

Pos.	Designation	Number	Part no.
③4	Cylinder temperature sensor, top	1	7438702
④2	Spring-loaded check valve	1	On site
④4	Immersion heater EHE		
	For top installation (can be regulated only by an internal temperature controller)	1	Z012684
	or		
	For lower installation	1	Z012677
④6	DHW circulation pump		See Vitoset pricelist
④8	Vitocell 100-V, type CVWA, 300 l/390 l/500 l	1	See Viessmann pricelist

9.14 Selecting cylinders for DHW heating and heating water storage

The advantage of a heating water buffer cylinder in combination with a freshwater module lies in the provision of demand-based, continuous DHW heating. Thermal storage occurs exclusively via the heating water, there is no need for storing large amounts of DHW.

DHW temperature in conjunction with heating water buffer cylinder and freshwater module

A heat pump operating in mono mode **cannot** ensure an outlet temperature of 60 °C at the freshwater module. If this is required, the heat pump must be operated in dual mode (e.g. with a peak load boiler).

Vitocal	Up to 5 occupants
	Vitocell 120-E, type SVW, 600 l
200-G	
BWC 201.A06	X
BWC 201.A08	X
BWC 201.A10	X
BWC 201.A13	X
BWC 201.A17	X

Further specifications for cylinders

See "Installation accessories" chapter and separate technical guides.

Vitocal	Up to 5 occupants
	Vitocell 120-E, type SVW, 600 l
300-G, single stage	
BW, BWC 301.B06	X
BW, BWC 301.B08	X
BW, BWC 301.B10	X
BW, BWC 301.B13	X
BW, BWC 301.B17	X

Design information (cont.)

Hydraulic connection of cylinders for DHW heating and heating water storage

Recommended for heat pumps up to 17.2 kW

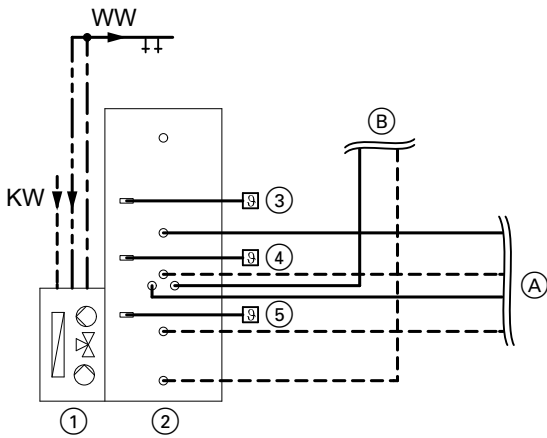

Hydraulic scheme with Vitocell 120-E, type SVW, 600 l

- (A) Heat pump connection
- (B) Secondary circuit connection
- KW Cold water
- WW DHW

Equipment required

Pos.	Description	Number
①	Vitotrans 353 freshwater module for cylinder mounting, type PZSA (part of Vitocell 120-E standard delivery) or Vitotrans 353 freshwater module for cylinder mounting, type PZMA (part of Vitocell 120-E standard delivery)	1
②	Vitocell 120-E, type SVW (600 l)	1
③	Cylinder temperature sensor	1
④	Temperature sensor for return stratification	1
⑤	Buffer temperature sensor	1

9.15 Loading cylinder selection

Loading cylinder

Loading cylinder	Capacity l	Max. heat pump heating output (single stage operation, flow temperature 60 °C) kW	Optional booster heater		Applications
			Immersion heater EHE (6 kW)	On-site instantaneous DHW heater (for preheated DHW)	
Vitocell 100-V Type CVAA	300	16	X	X	Up to 4 occupants
Vitocell 100-L Type CVL	500	32	X	X	Up to 8 occupants
	750	32	X	X	Up to 16 occupants
	1000	32	X	X	Up to 16 occupants

Design information (cont.)

Selecting Vitocell 100-L, type CVL

Vitocal	500 l	750 l	1000 l
300-G single stage			
BW, BWC 301.B06	X	–	–
BW, BWC 301.B08	X	–	–
BW, BWC 301.B10	X	–	–
BW, BWC 301.B13	X	–	–
BW, BWC 301.B17	X	–	–
BW 301.A21	X	X	X
BW 301.A29	X	X	X
BW 301.A45	X	X	X
300-G, two-stage			
BW+BWS 301.B06	X	X	X
BW+BWS 301.B08	X	X	X
BW+BWS 301.B10	X	X	X
BW+BWS 301.B13	X	X	X
BW+BWS 301.B17	X	X	X
BW+BWS 301.A21	X	X	X
BW+BWS 301.A29		DHW heating at stage 1	
BW+BWS 301.A45		DHW heating at stage 1	
350-G single stage			
BW 351.B20	X	X	X
BW 351.B27	X	X	X
BW 351.B33	X	X	X
BW 351.B42	X	X	X
350-G, two-stage			
BW+BWS 351.B20	X	X	X
BW+BWS 351.B27		DHW heating at stage 1	
BW+BWS 351.B33		DHW heating at stage 1	
BW+BWS 351.B42		DHW heating at stage 1	

Further specifications for DHW cylinders

See "Installation accessories" chapter and separate technical guides.

Hydraulic connection, cylinder loading system

DHW cylinder with external heat exchanger (cylinder loading system)

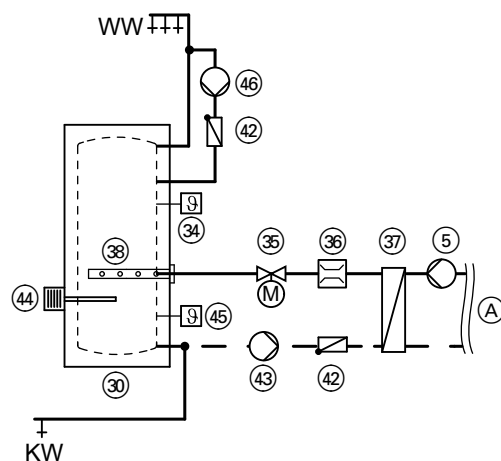

- (A) Heat pump connection
- KW Cold water
- WW DHW

Design information (cont.)

Equipment required

Pos.	Designation	Number	Part no.
⑤	Circulation pump for cylinder heating	1	7820403 or 7820404
③①	Vitocell 100-L, type CVL (500 l capacity)	1	See Viessmann pricelist
③④	Cylinder temperature sensor, top	1	7438702
③⑤	2-way motorised ball valve (N/C)	1	7180573
③⑥	Flow limiter (TacoSetter)	1	On site
③⑦	Vitotrans 100 plate heat exchanger	1	See page 168
③⑧	Heating lance	1	ZK00037
④②	Spring-loaded check valve	2	On site
④③	Cylinder loading pump	1	7820403 or 7820404
④④	Immersion heater EHE Create electrical circuit on site. Only use as an alternative to the instantaneous heating water heater or external heat generator for DHW reheating.	1	See Viessmann pricelist
④⑤	Cylinder temperature sensor, bottom (optional)	1	7438702
④⑥	DHW circulation pump	1	See Vitoset pricelist

DHW cylinder with external heat exchanger (cylinder loading system) and heating lance

During cylinder loading (no draw-off) in the cylinder loading system, cold water is drawn from the bottom of the DHW cylinder by the cylinder loading pump. This cold water is heated in the heat exchanger and resupplied to the DHW cylinder via the heating lance mounted in the flange.

The generously sized outlet apertures in the heating lance result in low flow velocities, which in turn provide a clean temperature stratification inside the DHW cylinder.

DHW booster heating is possible if an additional immersion heater is installed (on site).

Note

The flow rate in the DHW cylinder may be no more than 7 m³/h.

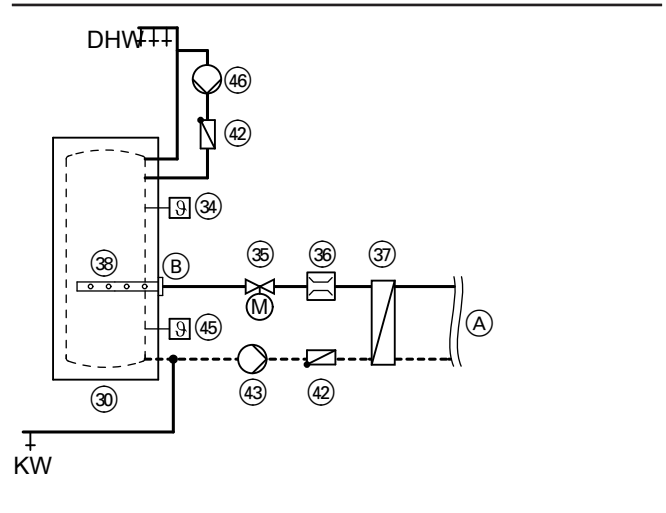

- KW Cold water
- WW DHW
- (A) Heat pump interface
- (B) DHW inlet from the heat exchanger

Equipment required

Pos.	Designation	Number	Part no.
③①	Vitocell 100-L (500, 750 or 1000 l capacity) or Vitocell 100-V, type CVAA (300 l capacity) or type CVA (500 l capacity)	1	See Viessmann pricelist
③④	Cylinder temperature sensor, top	1	7438702
③⑤	2-way motorised ball valve (N/C)	1	7180573
③⑥	Flow limiter (TacoSetter)	1	On site
③⑦	Vitotrans 100 plate heat exchanger	1	See page 168
③⑧	Heating lance	1	See Viessmann pricelist
④②	Spring-loaded check valve	1	On site
④③	Cylinder loading pump	1	7820403 or 7820404
④⑤	Cylinder temperature sensor, bottom (optional)	1	7438702
④⑥	DHW circulation pump	1	See Vitoset pricelist

Design information (cont.)

DHW cylinder with external heat exchanger and solar backup

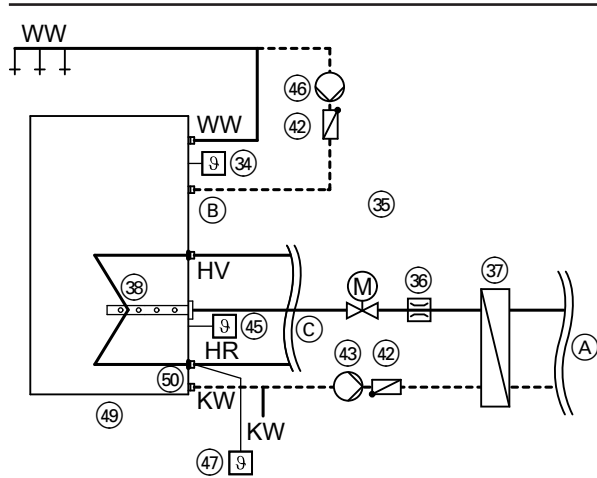

- (A) Heat pump connection
- (B) DHW circulation connection
- (C) Solar circuit connection
- HR Solar circuit flow
- HV Solar circuit return
- KW Cold water
- WW DHW

Equipment required

Pos.	Designation	Number	Part no.
(34)	Cylinder temperature sensor, top	1	7438702
(35)	2-way motorised ball valve (N/C)	1	7180573
(36)	Flow limiter (TacoSetter)	1	On site
(37)	Vitotrans 100 plate heat exchanger	1	See page 168
(38)	Heating lance	1	ZK00038
(42)	Spring-loaded check valve	2	On site
(43)	Circulation pump for cylinder heating	1	7820403 or 7820404
(45)	Cylinder temperature sensor	1	7438702
(46)	DHW circulation pump	1	See Vitoset pricelist
(47)	Cylinder temperature sensor (standard delivery with solar control module, type SM1 or Solar-Divicon, type PS 10)	1	7429073
(49)	Vitocell 100-V, type CVAA (300 l capacity) or type CVA (500 l capacity)	1	See Viessmann pricelist
(50)	Threaded elbow as retainer for the cylinder temperature sensor (pos. (45))	1	7175214

Vitotrans 100 plate heat exchanger

Note

For heat exchanger pressure drop values, see the technical guides for solar thermal systems and heating water buffering.

Design information (cont.)

Flow rate and pressure drop at B15/W35

Vitocal	Heating output in kW	Flow rate in m ³ /h		Pressure drop in kPa		Vitotrans 100 Part no.
		DHW cylinder (A) (domestic hot water)	Heat pump (B) (heating water)	DHW cylinder (A) (domestic hot water)	Heat pump (B) (heating water)	

300-G, single stage and two-stage: 10 K spread

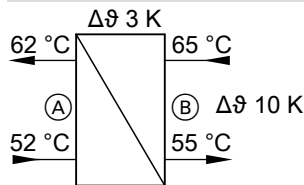

300-G, single stage

BW, BWC 301.B06	8.6	0.8	0.8	3.2	3.9	3003492
BW, BWC 301.B08	11.3	1.0	1.0	5.5	6.6	3003492
BW, BWC 301.B10	15.4	1.4	1.4	3.7	4.1	3003493
BW, BWC 301.B13	19.2	1.7	1.7	5.6	6.2	3003493
BW, BWC 301.B17	26.1	2.3	2.3	10.0	11.1	3003493

300-G, two-stage

BW+BWS 301.B06	17.2	1.5	1.5	4.5	5.0	3003493
BW+BWS 301.B08	22.6	2.0	2.0	7.6	8.5	3003493
BW+BWS 301.B10	30.8	2.7	2.7	6.8	7.3	3003494
BW+BWS 301.B13	38.4	3.4	3.4	10.4	11.2	3003494
BW+BWS 301.B17	52.2	4.6	4.6	10.6	11.1	3003495

300-G, single stage: 5 K spread

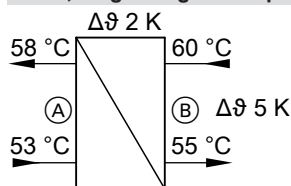

BW 301.A21	31.0	5.4	5.4	26.0	27.9	3003494
BW 301.A29	41.2	7.2	7.2	25.4	26.6	3003495
BW 301.A45	63.6	11.1	11.1	—	—	On request

300-G, single stage: 10 K spread

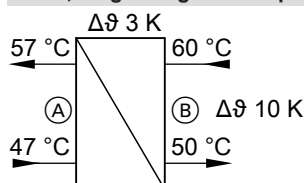

BW 301.A21	31.0	2.7	2.7	13.9	15.5	3003493
BW 301.A29	41.2	3.6	3.6	12.0	12.8	3003494
BW 301.A45	63.6	5.6	5.6	15.5	16.2	3003495

350-G 1-stage: Spread 6 K: Sizing for a DHW temperature of 60 °C in the loading cylinder (see application limits)

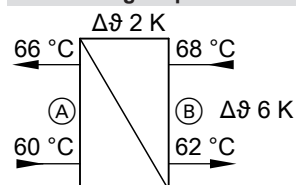

BW 351.B20	—	—	—	—	—	—
BW 351.B27	35.0	5.1	5.1	13.0	13.6	3003495
BW 351.B33	43.0	6.3	6.3	19.3	20.2	3003495
BW 351.B42	54.0	7.9	7.9	—	—	On request

Note

The maximum achievable flow temperature of the heat pump depends on the flow temperatures in the primary circuit (brine inlet): See application limits of the relevant heat pump.

Where brine inlet temperatures are outside these application limits (very low or very high temperatures), the heat pump can no longer provide the maximum flow temperature.

Cylinder loading pump curves

See page 118.

9.16 Cooling mode

Types and configuration

Subject to system version the following cooling functions are possible:

- "Natural cooling"
 - The compressor is switched off. Exchange of heat takes place directly through the primary circuit.
- "Active cooling"
 - The heat pump is used as a refrigeration unit, meaning a higher cooling capacity is possible than with natural cooling.
 - This function is only possible outside a power-OFF period, and must be enabled separately by the system user.

Even if active cooling is selected and enabled, the control unit will initially start the natural cooling function. If the set room temperature cannot be achieved with this function for a prolonged period, the compressor starts.

A mixer can only be used with natural cooling, and particularly in cooling mode on underfloor heating circuits, it keeps the flow temperature above the dew point. To ensure the transfer of the high cooling output in active cooling at all times, no mixer is provided.

Natural cooling function

Function description

With natural cooling, the heat pump control unit regulates the following functions:

- Switching all necessary circulation pumps, diverter valves & mixers
- Recording all essential temperatures
- Dew point monitoring

The control unit enables the natural cooling function if the outside temperature exceeds the cooling limit (adjustable). Control in weather-compensated mode when cooling via a heating circuit (underfloor heating circuit). When a separate cooling circuit is used, e.g. a fan convector, then control is room temperature-dependent. DHW heating by the heat pump is possible during cooling mode.

Note

- For cooling operation via a separate cooling circuit, a room temperature sensor must be installed and enabled.
- For cooling operation via a separate cooling circuit or heating circuit without mixer, use a contact temperature sensor to capture the flow temperature.

NC-Box

- The installation room must be dry and free from the risk of frost.
- Vitocal 200-G/300-G: Install the NC-Box inside the installation room above the heat pump and connect using the NC-Box hydraulic connection set (accessories).
- Compact heat pumps: Install the NC-Box close to the compact heat pump and use on-site pipes for the hydraulic connection.
- Insulate all brine and cold water lines with vapour diffusion-proof thermal insulation in accordance with engineering standards to prevent condensation.
- Power supply (1/N/PE, 230 V/50 Hz) is required.
Recommendation: Utilise the heat pump power supply from an on site power distribution board.
- If the NC-Box is operated via a separate cooling circuit (used exclusively for cooling), protect this circuit by means of an additional expansion vessel and safety valve.
- Use only Teflon and EPDM seals for the connections on the NC-Box.

Natural cooling with the NC-Box

Subject to the probe/collector system and the temperatures under ground, the NC-Box can transfer a cooling capacity of up to 5 kW. For cooling, it is possible to connect either a heating/cooling circuit, e.g. underfloor heating circuit, or a separate cooling circuit, e.g. a fan convector.

The NC-Box is supplied with all necessary components:

- Circulation pumps
- Diverter valves
- Mixers
- Sensors
- KM-BUS interface for heat pump control unit

The heat that is extracted from the heating/cooling circuit is transferred to the ground by the NC-Box. This heat exchanger is connected in series and enables system separation between the primary and the heating circuit.

Note

Thermally insulate all lines on site with vapour diffusion-proof material.

Arrangement of the NC-Box adjacent to the heat pump

- In compact heat pump appliances Vitocal 222-G, 333-G
- For Vitocal 200-G, 300-G, if there is insufficient space above the heat pump to carry out the installation.
- Hydraulic connection is made using on-site pipework.

Arrangement of the NC-Box above the heat pump

- For Vitocal 200-G, 300-G type BWC 301.B06 to B17
- Hydraulic connection is carried out using the NC-Box connection set (accessories)

Note

*The NC-Box hydraulic connection set **cannot** be used in conjunction with a heating water buffer cylinder.*

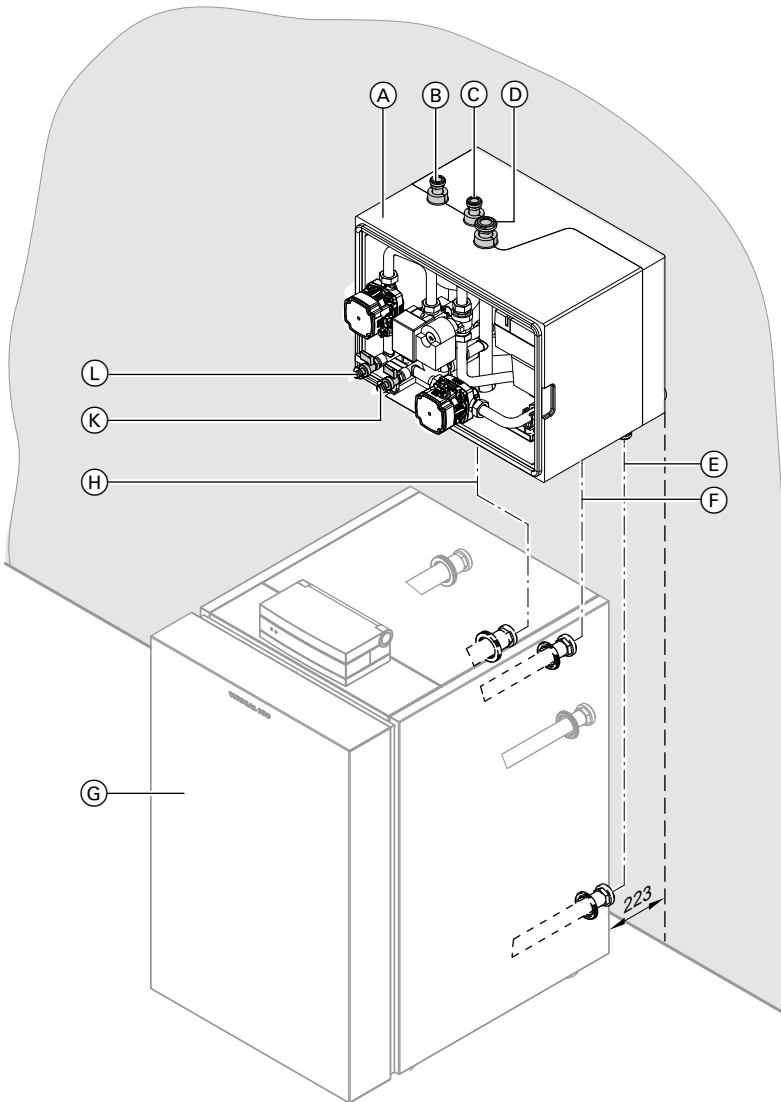

- (A) NC-Box
- (B) Return, heating/cooling circuit or separate cooling circuit
- (C) Flow, heating/cooling circuit or separate cooling circuit
- (D) Flow, primary circuit (NC-Box brine inlet)
- (E) Return, secondary circuit to heat pump
- (F) Flow, secondary circuit to the NC-Box
- (G) Heat pump
- (H) Flow, primary circuit (heat pump brine inlet)
- (K) Primary circuit BDF valve (brine)
- (L) BDF valve, secondary circuit (heating water)

Cooling with an underfloor heating system

The underfloor heating system can be used for heating and for cooling buildings and rooms.

Underfloor heating systems are hydraulically connected to the brine circuit via a cooling heat exchanger. A mixer is required to match the cooling load of the room to the outside temperature. Similar to a heating curve, the cooling capacity can be matched exactly to the cooling load via a cooling curve and the cooling circuit mixer that is regulated by the heat pump control unit.

Surface temperature limits must be maintained to observe comfort criteria and to prevent condensation. The surface temperature of the underfloor heating system in cooling operation must not fall below 20 °C.

Install a natural cooling contact humidistat (for capturing the dew point) in the underfloor heating system flow to prevent condensation forming on the floor surface. This safely prevents the formation of condensate, even if weather conditions change quite rapidly (e.g. during a thunderstorm).

The underfloor heating system should be sized in accordance with a flow/return temperature pair of approx. 14/18 °C.

The following table can assist in estimating the possible cooling capacity of an underfloor heating system.

In principle, the following applies:

The minimum flow temperature for cooling with an underfloor heating system and the minimum surface temperature are subject to the prevailing ambient conditions inside the room (air temperature and relative humidity). These must therefore also be taken into consideration during the design phase.

5822541

Design information (cont.)

Estimating cooling capacity of an underfloor heating system subject to floor covering and the spacing between pipe runs (assumed floor temperature of approx. 16 °C, return temperature approx. 20 °C)

Floor covering	mm	Tiles			Carpet		
		75	150	300	75	150	300
Cooling capacity with pipe diameter							
-10 mm	W/m ²	40	31	20	27	23	17
-17 mm	W/m ²	41	33	22	28	24	18
-25 mm	W/m ²	43	36	25	29	26	20

Details accurate for:

Room temperature	26 °C
Rel. humidity	50 %
Dew point temperature	15 °C

Active cooling function

Function description

Brine/water and water/water heat pumps can, during spring, summer or autumn, utilise the temperature level of what is used as a heat source in winter as a heat sink, i.e. to cool the building with natural cooling.

At the same time, active cooling can be achieved by starting the compressor and reversing the functions of the primary and secondary sides.

The heat generated is dissipated via the primary source (or a consumer).

The AC-Box always responds initially to a cooling demand with the natural cooling function.

If the cooling capacity is no longer sufficient, the system changes over to the active cooling function.

The heat pump starts to operate and the cold side (primary circuit) and hot side (secondary circuit) are changed over via the AC-Box. The heat generated is made available to the connected consumers (e.g. DHW cylinder). Excess heat is dissipated into the ground or well system.

To prevent the geothermal collectors or probes being overloaded (risk of drying out), the temperature and its spread are permanently monitored by the heat pump control unit. If overloading occurs, the system automatically changes over to natural cooling.

All required circulation pumps, valves and mixers inside the AC-Box are regulated by the heat pump control unit.

A contact humidistat must be fitted to a free pipe piece outside the AC-Box.

Note

- For cooling operation via a separate cooling circuit, a room temperature sensor must be installed and enabled.
- A cascade of several AC-Boxes is not possible. The maximum cooling capacity is limited by the cooling capacity of the connected heat pump, and by the sizing of the primary source.

AC-Box: For Vitocal 300-G, type BW, BWS, BWC 301.B06 to B17 only

Layout

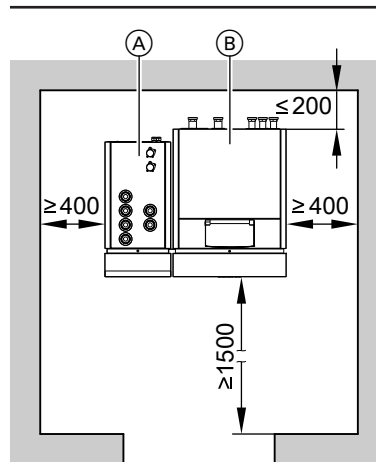

- (A) AC-Box
- (B) Heat pump

We recommend positioning the AC-Box to the left of the heat pump. This enables access to the internal components from the front or the left. The connection set (see chapter "Installation accessories") is designed for this method of connection.

Note

If the appliance is installed together with a heat pump (type BW) for which no connection set is available, the connection must be made on site, because additional pumps need to be installed.

Sizing

The maximum cooling capacity of the AC-Box is limited by the heat pump.

Example:

For the Vitocal 300-G, type BW 301.B06, the maximum system cooling capacity is 4.54 kW.

Conditions:

- The installed primary source has been sized for the output.
- The installed primary source can transfer the generated heat.

Note

For operation with the AC-Box, inform the engineer or drilling contractor about the sizing. The primary source must be correspondingly larger.

Design information (cont.)

Hydraulic connection

We recommend connecting the AC-Box to the heat pump with the connection set (see chapter "Installation accessories").

Information on the connection set:

- Only for connecting the Vitocal 300-G, type BWC to the AC-Box
- The connection set is thermally insulated.
- Not suitable for systems with heating water buffer cylinder

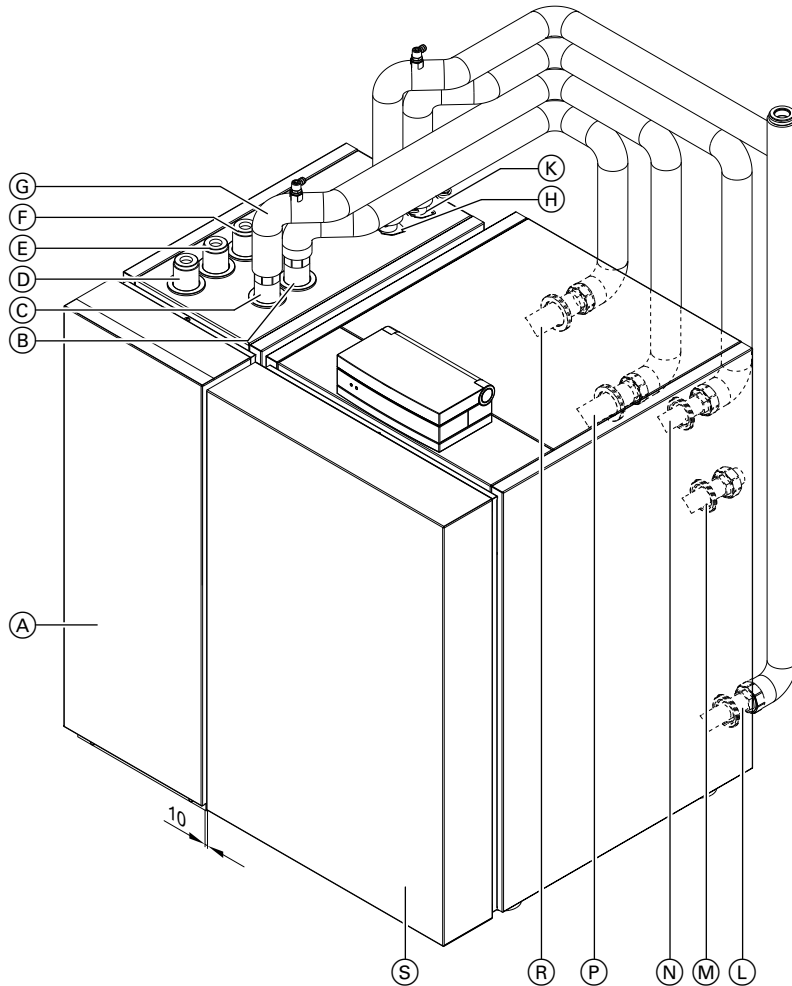

- | | |
|---|--|
| <p>(A) AC-Box</p> <p>(B) Connection, heat pump primary circuit–AC-Box: Brine entry, AC-Box from connection (R)</p> <p>(C) Connection, primary circuit AC-Box–heat pump: Brine outlet, AC-Box to connection (P)</p> <p>(D) Flow, primary circuit (brine outlet, AC-Box)</p> <p>(E) Return, primary circuit (brine inlet, AC-Box)</p> <p>(F) Flow, heating/cooling circuit or separate cooling circuit</p> <p>(G) Return, heating/cooling circuit or separate cooling circuit</p> <p>(H) Connection, secondary circuit AC-Box–heat pump: Heating water outlet, AC-Box to connection (L)</p> | <p>(K) Connection, secondary circuit heat pump–AC-Box: Heating water inlet, AC-Box from connection (N)</p> <p>(L) Connection, secondary circuit AC-Box–heat pump: Heating water inlet, heat pump from connection (H)</p> <p>(M) DHW cylinder flow</p> <p>(N) Connection, secondary circuit heat pump–AC-Box: Heating water outlet, heat pump to connection (K)</p> <p>(P) Connection, heat pump primary circuit–AC-Box: Brine outlet, heat pump to connection (C)</p> <p>(R) Connection, primary circuit AC-Box–heat pump: Brine inlet, heat pump from connection (B)</p> <p>(S) Heat pump</p> |
|---|--|

Electrical connection

All entries for electrical connections are on the back of the AC-Box.

The following components in both connecting chambers are electrically connected behind the front casing cover, at factory:

- Power cable 230 V~
- Control / input signal AC (active cooling)
- Control / input signal NC (natural cooling)
- Signal line for shutdown in case of a compressor fault

If required, the following components must be connected on site:

- Contact humidistat (accessories)
- Additional frost stat (accessory)

Contact humidistat

If surface cooling systems (e.g. underfloor cooling, cooling ceiling) are used, a contact humidistat (accessory) is required.

Design information (cont.)

- The contact humidistat is connected to the cooling water flow (see previous diagram).
- The contact humidistat must be installed where indoor air can reach the inside of the casing. It can alternatively be installed in a reference room.
- If very different room conditions are expected with regard to the air humidity, several contact humidistats may have to be used.
- If several contact humidistats are used, the switching contacts must be connected as N/C and in series.

9.17 Swimming pool heating

Hydraulic connection, swimming pool

Swimming pool heating is effected hydraulically via the changeover of a second 3-way diverter valve (accessories).
If the temperature falls below the value set at the swimming pool temperature controller (accessories), a demand signal is sent to the heat pump control unit via the external EA1 extension (accessories).
In the delivered condition, central heating and DHW heating have priority over swimming pool heating.

For more detailed information regarding systems with swimming pool heating, see www.viessmann-schemes.com.

Sizing the plate heat exchanger

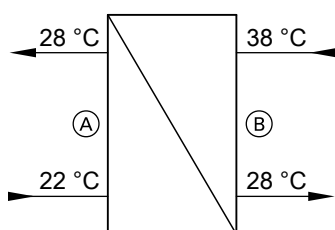

Use only stainless steel plate heat exchangers (threaded) that are suitable for potable water for swimming pool heating.
Size the plate heat exchanger subject to the maximum output and the temperature specified for the plate heat exchanger.

Note

The flow rates calculated during sizing must be maintained during the installation.

External swimming pool for average water temperatures up to 25 °C.

- (A) Swimming pool (swimming pool water)
- (B) Heat pump (heating water)

Selecting a plate heat exchanger for a swimming pool

Vitocal	Heating output at B15/W35 kW	Swimming pool flow rate m ³ /h	Heat pump flow rate m ³ /h
200-G			
BWC 201.A06	8.3	1.2	0.7
BWC 201.A08	11.2	1.6	1.0
BWC 201.A10	14.1	2.0	1.2
BWC 201.A13	18.6	2.7	1.6
BWC 201.A17	24.6	3.5	2.1
300-G, single stage			
BW, BWC 301.B06	8.6	1.2	0.7
BW, BWC 301.B08	11.3	1.6	1.0
BW, BWC 301.B10	15.4	2.2	1.3
BW, BWC 301.B13	19.2	2.8	1.7
BW, BWC 301.B17	26.1	3.7	2.2
BW 301.A21	31.0	4.4	2.7
BW 301.A29	41.2	5.9	3.5
BW 301.A45	63.6	9.1	5.5
300-G, two-stage			
BW+BWS 301.B06	17.2	2.5	1.5
BW+BWS 301.B08	22.6	3.2	1.9
BW+BWS 301.B10	30.8	4.4	2.6
BW+BWS 301.B13	38.4	5.5	3.3
BW+BWS 301.B17	52.2	7.5	4.5
BW+BWS 301.A21	62.0	8.9	5.3
BW+BWS 301.A29	82.4	11.8	7.1
BW+BWS 301.A45	127.2	18.2	10.9

Design information (cont.)

Vitocal	Heating output at B15/W35 kW	Swimming pool flow rate m ³ /h	Heat pump flow rate m ³ /h
350-G single stage			
BW 351.B20	26.0	3.7	2.2
BW 351.B27	35.0	5.0	3.0
BW 351.B33	43.0	6.2	3.7
BW 351.B42	54.0	7.7	4.6
350-G, two-stage			
BW+BWS 351.B20	52.0	7.5	4.5
BW+BWS 351.B27	70.0	10.0	6.0
BW+BWS 351.B33	86.0	12.3	7.4
BW+BWS 351.B42	108.0	15.5	9.3
222-G			
BWT-M 221.B06	8.7	1.2	0.7
BWT-M 221.B08	11.3	1.6	1.0
BWT-M 221.B10	15.3	2.2	1.3
333-G			
BWT 331.C06	12.5	1.8	1.1
BWT 331.C12	16.2	2.3	1.4

9.18 Integrating a solar thermal system

In conjunction with a solar control unit, a solar thermal system can be controlled for DHW heating, central heating backup and swimming pool heating. The heat-up priority can be selected individually at the heat pump control unit.

The heat pump control unit enables certain values to be checked. When there is a high level of insolation, all heat consumers can be heated to a higher set value, thereby raising the solar coverage. All solar temperatures and set values can be scanned and adjusted via the control unit.

To prevent thermal shocks inside the solar circuit, the operation of the solar thermal system will be interrupted at collector temperatures > 120 °C (collector protection).

Solar DHW heating

The solar circuit pump starts and the DHW cylinder is heated up if the temperature differential between the collector temperature sensor and the cylinder temperature sensor (in the solar circuit return) is greater than the start temperature differential set at the solar control unit.

The heat pump will be prevented from heating the cylinder if the temperature at the cylinder temperature sensor (in the DHW cylinder, top) exceeds the set value selected at the heat pump control unit. The solar thermal system heats the cylinder to the set value selected at the solar control unit.

Note

- Hydraulic connection: See www.viessmann-schemes.com.
- Aperture area that can be connected: See the "Vitosol" technical guide.

Solar central heating backup

The solar circuit pump and the circulation pump for cylinder heating start if the temperature differential between the collector temperature sensor and the cylinder temperature sensor (solar) is greater than the start temperature differential selected at the heat pump control unit. The heating water buffer cylinder is heated.

Heating stops when the temperature differential between the collector temperature sensor and the cylinder temperature sensor (solar) is less than half the hysteresis (standard: 6 K) or if the actual temperature captured by the lower cylinder temperature sensor corresponds to the selected set temperature.

See also the "Vitosol" technical guide.

Solar swimming pool heating

See "Vitosol" technical guide.

Solar control unit

- Vitocal 200-G, 300-G and 350-G:
Solar control module, type SM1 (accessories, see page 191).

Note

The Solar-Divicon (part no. Z017690) also includes a solar control module: SDIO/SM1A electronics module

- Vitocal 222-G and 333-G:
 - With solar heat exchanger set (accessories) and for solar circuit pump with control via PWM signal:
Solar control module, type SM1 (accessories, see page 191).
 - With Solar-Divicon, type PS10 (part No. Z017690)
SDIO/SM1A integrated electronics module
- See Viessmann pricelist, register 13.

Connecting solar collectors to the Vitocal 222-G, 333-G

Up to 5 m² of flat-plate collectors (Vitosol 200-F/300-F) or 3 m² of tube collectors (Vitosol 200-T/300-T) can be connected to the compact heat pumps. Connection to the appliance is implemented with the solar heat exchanger set (Divicon, accessories). The required control function are integrated.

Install pipework from the collector area to the compact heat pump on site. Connect a suitably sized expansion vessel to the pipework to be installed. Provide thermal insulation for the pipework using a material capable of withstanding temperatures up to 185 °C. This requirement also applies to the use of fixing clamps.

Design information (cont.)

To achieve the required pump rate it is necessary to calculate the pressure drop of the pipework together with the collector area. With regard to implementation, installation, calculation and application limits of the solar thermal system, the latest version of the technical guide, service instructions and installation instructions for the solar thermal system apply.

Sizing the solar expansion vessel

Solar expansion vessel

Design and function

With shut-off valve and fixings

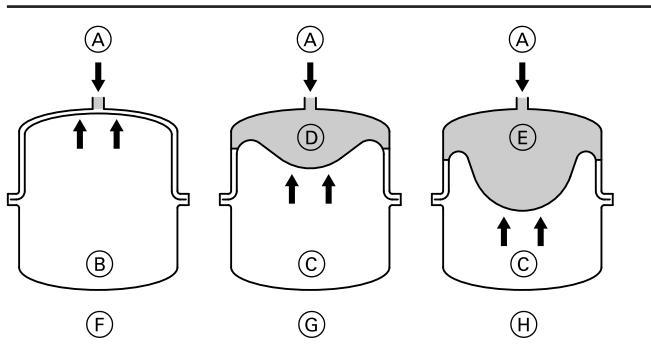

- (A) Heat transfer medium
- (B) Nitrogen charge
- (C) Nitrogen buffer
- (D) Minimum safety seal 3 l
- (E) Safety seal
- (F) Delivered condition (pre-charge pressure 4.5 bar, 0.45 MPa)
- (G) Solar thermal system filled, without heat effect
- (H) At maximum pressure and the highest heat transfer medium temperature

A solar expansion vessel is a sealed vessel where the gas space (nitrogen charge) is separated from the space containing liquid (heat transfer medium) by a diaphragm and the pre-charge pressure is subject to the system height.

Specification

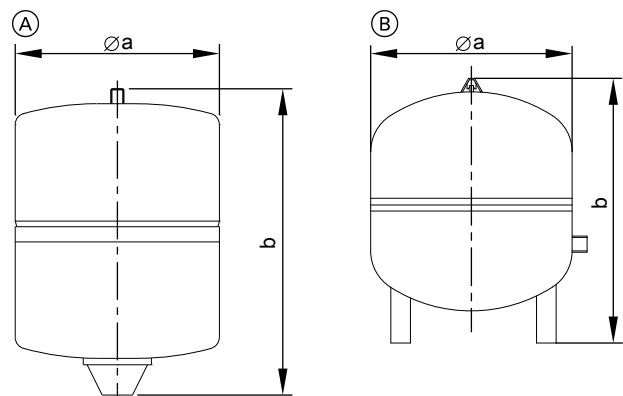

Expansion vessel	Part no.	Capacity l	Pre-charge pressure bar (MPa)	Ø a mm	b mm	Connection	Weight kg
(A)	7248241	18	4.5 (0.45)	280	370	R ¾	7.5
	7248242	25	4.5 (0.45)	280	490	R ¾	9.1
	7248243	40	4.5 (0.45)	354	520	R ¾	9.9
(B)	7248244	50	4.5 (0.45)	409	505	R 1	12.3
	7248245	80	4.5 (0.45)	480	566	R 1	18.4

Note

Included in standard delivery with solar packs

For details on the calculation of the required volume, see the "Vitosol" technical guide.

9.19 Tightness test on the refrigerant circuit

Heat pump refrigerant circuits containing a refrigerant with a CO₂ equivalent of 5 t or more must be tested regularly for tightness in accordance with EU Regulation No. 517/2014. In the case of hermetically sealed refrigerant circuits, this regular testing is required for a CO₂ equivalent of 10 t or more.

The intervals at which the refrigerant circuits will need to be tested depend on the level of CO₂ equivalent. If leak detection facilities are available on site, the test intervals are extended.

Vitocal	Tightness test
200-G	
BWC 201.A06	No
BWC 201.A08	No
BWC 201.A10	No
BWC 201.A13	No
BWC 201.A17	No

Design information (cont.)

Vitocal	Tightness test
300-G, single stage and two-stage	
BW, BWS, BWC 301.B06	No
BW, BWS, BWC 301.B08	No
BW, BWS, BWC 301.B10	No
BW, BWS, BWC 301.B13	No
BW, BWS, BWC 301.B17	No
BW, BWS 301.A21	No
BW, BWS 301.A29	Every 12 months
BW, BWS 301.A45	Every 12 months
350-G, single stage and two-stage	
BW, BWS 351.B20	Every 12 months
BW, BWS 351.B27	Every 12 months
BW, BWS 351.B33	Every 12 months
BW, BWS 351.B42	Every 12 months
222-G	
BWT-M 221.B06	No
BWT-M 221.B08	No
BWT-M 221.B10	No
333-G	
BWT 331.C06	No
BWT 331.C12	No

9.20 Intended use

The appliance is only intended to be installed and operated in sealed unvented heating systems that comply with EN 12828, with due attention paid to the associated installation, service and operating instructions.

Depending on the version, the appliance can only be used for the following purposes:

- Central heating
- Central cooling
- DHW heating

The range of functions can be extended with additional components and accessories.

Intended use presupposes that a fixed installation in conjunction with permissible, system-specific components has been carried out.

Commercial or industrial usage for a purpose other than central heating/cooling or DHW heating shall be deemed inappropriate.

Incorrect usage or operation of the appliance (e.g. the appliance being opened by the system user) is prohibited and will result in an exclusion of liability. Incorrect usage also occurs if the components in the heating system are modified from their intended function.

Note

The appliance is intended exclusively for domestic or semi-domestic use, i.e. even users who have not had any instruction are able to operate the appliance safely.

Heat pump control unit, type WO1C

10.1 Vitotronic 200, type WO1C

Design and functions

Modular design

The control unit comprises the standard modules, PCBs and the programming unit.

Standard modules:

- ON/OFF switch
- Optolink interface
- Operating and fault display
- Fuses

PCBs for connecting external components:

- Connections for 230 V~ components, such as pumps, mixers etc.
- Connections for signal and safety components
- Connections for temperature sensors and KM BUS

Programming unit

- Straight forward operation:
 - Plain text display with graphic ability
 - Large font and black/white depiction for good contrast
 - Context-sensitive help texts
- With time switch
- Operating keys:
 - Navigation
 - Confirmation
 - Help
 - Extended menu



Heat pump control unit, type WO1C (cont.)

- Settings:
 - Standard and reduced room temperature
 - Standard and second DHW temperature
 - Operating program
 - Time programs, e.g. for central heating, DHW heating, DHW circulation and heating water buffer cylinder
 - Economy mode
 - Party mode
 - Holiday program
 - Heating and cooling curves
 - Parameter
- Display:
 - Flow temperatures
 - DHW temperature
 - Information
 - Operating data
 - Diagnostic details
 - Information, warning and fault messages
- Available languages:
 - German
 - Bulgarian
 - Czech
 - Danish
 - English
 - Spanish
 - Estonian
 - French
 - Croatian
 - Italian
 - Latvian
 - Lithuanian
 - Hungarian
 - Dutch
 - Polish
 - Russian
 - Romanian
 - Slovenian
 - Finnish
 - Swedish
 - Turkish

Functions

- Electronic maximum and minimum temperature limit
- Demand-dependent shutdown of the heat pump and the pumps for the primary and secondary circuits
- Adjustment of a variable heating and cooling limit
- Pump anti-seizing protection
- Monitoring frost protection of system components
- Integral diagnostic system
- Cylinder temperature controller with priority control
- Auxiliary function for DHW heating (short-term heating to a higher temperature)
- Control of a heating water buffer cylinder
- Screed drying program
- External hook-ups: Mixer OPEN, mixer CLOSE, changeover of operating mode (with external EA1 extension, accessories)
- External demand (adjustable set flow temperature) and heat pump blocking, specifying the set flow temperature via an external 0 to 10 V signal (with external EA1 extension, accessories)
- Function check of controlled components, e.g. circulation pumps
- Optimised utilisation of power generated by the photovoltaic system (on-site power consumption)
- Control and operation of compatible Viessmann ventilation units

Functions subject to heat pump type

	Vitocal				
	200-G	300-G	350-G	222-G	333-G
Weather-compensated control of the flow temperatures for heating or cooling mode					
– System flow temperature or flow temperature of heating circuit without mixer A1	X	X	X	X	X
– Flow temperature, heating circuit with mixer M2: Direct control of the mixer motor by the control unit Control of the mixer motor via the KM-BUS	X	X	X	X	X
– Flow temperature, heating circuit with mixer M3: Control of the mixer motor via the KM-BUS	—	X	X	X	X
– Flow temperature for cooling via a heating/cooling circuit or separate cooling circuit	X	X	X	X	X
Cooling function					
– Natural cooling function (NC)	X	X	X	X	X
– Active cooling function (AC)	—	X	X	—	—
Solar DHW heating/central heating backup For solar circuit pump with control via PWM signal					
– Control with solar control module, type SM1 (accessories)	X	X	X	—	—
– With solar heat exchanger set (accessories)	—	—	—	X	X
– Control unit with SDIO/SM1A electronics module (integrated in Solar-Divicon, type PS 10)					
Control of external heat generator (e.g. oil/gas boiler)	X	X	X	—	—
Control of instantaneous heating water heater	X	X	X	X	X
Control of Viessmann ventilation unit	X	X	X	X	X
Optimised utilisation of power generated on site	X	X	X	X	X
Control of swimming pool heating	X	X	X	X	X

5822541

Heat pump control unit, type WO1C (cont.)

	Vitocal 200-G	300-G	350-G	222-G	333-G
Control of heat pump cascade – For up to 5 Vitocal appliances via LON, LON communication module required (accessories)	—	X	X	—	—
Connection to higher ranking KNX/EIB system Via Vitogate 200, type KNX (LON communication module required, accessories)	X	X	X	X	X

Data communication overview

Device	Vitoconnect type OPTO2		Vitocom 100 type LAN1		Vitocom 300 type LAN3	
	ViCare app	Vitoguide	Vitotrol app	Vitodata 100	Vitodata 100	Vitodata 300
Operation	WiFi	Email	Ethernet, IP networks	Email, SMS, fax	Ethernet, IP networks	Email, SMS, fax
Communication	Push notification		Vitotrol app			
Max. number of heating systems	1	1	1	1	1	5
Max. number of heating circuits	3	3	3	32	32	32
Remote monitoring	X	X	X	X	X	X
Telecontrol	X	X	X	X	X	X
Remote setting (setting the heat pump control parameters)	–	–	–	–	–	X
Linking in the heat pump control unit	Optolink	Optolink	LON	LON	LON	LON
Accessories required for the heat pump control unit	–	–	Communication module (Vitocom standard delivery or accessories)			

Information on Vitoconnect

Heating system: Only 1 heat generator

Information on Vitodata 100

The full extent of the heat pump energy statement cannot be retrieved.

The requirements of EN 12831 for calculating the heat load are met. To reduce the heat-up output, the "Reduced" operating status is switched to the "Standard" operating status if outside temperatures are low.

According to the [German] Energy Saving Ordinance, the temperature in each room must be individually controlled, e.g. by means of thermostatic valves.

Time switch

Digital time switch (integrated into the programming unit)

- Individual day and seven-day program
- Automatic summer/wintertime changeover
- Automatic function for DHW heating and DHW circulation pump
- Standard switching times are preset at the factory, e.g. for central heating, DHW heating, charging a heating water buffer cylinder and switching the DHW circulation pump.
- Time program is individually adjustable; up to 8 time phases per day
Shortest switching interval: 10 min
Power reserve: 14 days

Setting the operating programs

Frost protection monitoring for the system components is enabled in all operating programs (see frost protection function).

You can select the following operating programs via the menu:

- For heating/cooling circuits:
"Heating and DHW" or "heating, cooling and DHW"
- For a separate cooling circuit:
"Cooling"
- "Only DHW"; separate settings for each heating circuit

Note

If the heat pump only needs to be on for DHW heating (e.g. in the summer), the operating program "Only DHW" must be selected for all heating circuits.

- "Standby mode"
Frost protection only

The operating programs can also be switched over externally, e.g. by Vitocom 100.

Frost protection function

- If the outside temperature falls below +1 °C, the frost protection function is switched on.
With active frost protection, the heating circuit pump will be switched on and the flow temperature in the secondary circuit will be maintained at a lower temperature of approx. 20 °C.
The DHW cylinder will be heated to approx. 20 °C.
- If the outside temperature exceeds +3 °C, the frost protection function is switched off.

Heating and cooling curve settings (slope and level)

The Vitotronic 200 regulates the flow temperatures for the heating/cooling circuits in weather-compensated mode:

- System flow temperature or flow temperature of heating circuit without mixer A1
- Flow temperature, heating circuit with mixer M2:
Depending on the heat pump, the mixer motor is controlled either directly by the control unit or via the KM-BUS.
- Flow temperature, heating circuit with mixer M3:
Not available on all heat pumps; mixer motor control via the KM-BUS
- Flow temperature for cooling via heating circuit; the separate cooling circuit is regulated depending on the room temperature.

The flow temperature required to reach a specific room temperature depends on the heating system and the thermal insulation of the building to be heated or cooled.

Adjusting the heating or cooling curves matches the flow temperature to these conditions.

- Heating curves:
The flow temperature of the secondary circuit is restricted at the upper end of the scale by the temperature limiter and the maximum temperature set at the heat pump control unit.

- Cooling curves:
The flow temperature of the secondary circuit is restricted at the lower end of the scale by the minimum temperature set at the heat pump control unit.

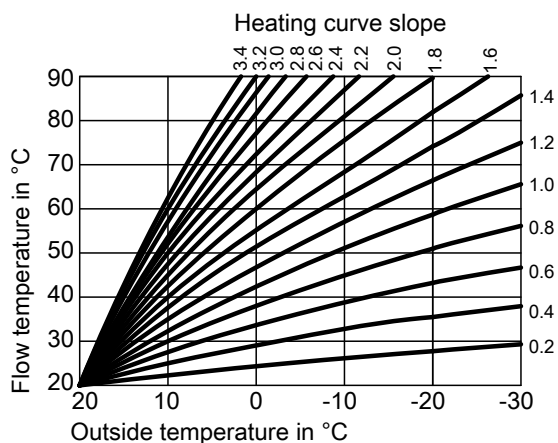
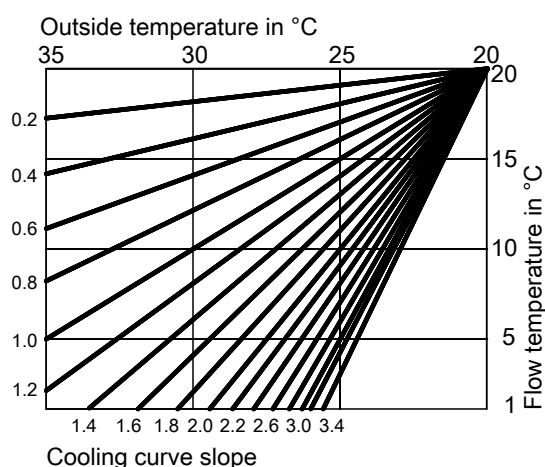

Heating systems with heating water buffer cylinder

When using hydraulic separation, a temperature sensor must be integrated in the heating water buffer cylinder. This temperature sensor is connected to the heat pump control unit.

Outside temperature sensor

Installation location:

- North or north-west facing wall of the building
- 2 to 2.5 m above the ground, for multi storey buildings in the upper half of the second floor

Connection:

- 2-core lead, length up to 35 m with a cross-section of 1.5 mm² (copper)
- Never route this lead immediately next to 230 V/400 V cables.

Heat pump control unit, type WO1C (cont.)

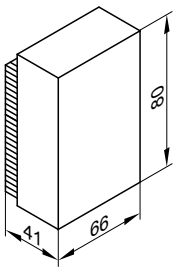

Specification

IP rating	IP 43 to EN 60529; ensure through design/installation.
Sensor type	Viessmann NTC 10 kΩ at 25 °C
Permissible ambient temperature during operation, storage and transport	-40 to +70 °C

10.2 Specification Vitotronic 200, type WO1C

General

Rated voltage	230 V~
Rated frequency	50 Hz
Rated current	6 A
Protection class	I
Permissible ambient temperature	
- Operation	0 to +40 °C Installation in living spaces or boiler rooms (standard ambient conditions)
- Storage and transport	-20 to +65 °C
DHW temperature setting range	10 to +70 °C
Heating and cooling curves setting range	
- Slope	0 to 3.5
- Level	-15 to +40 K

Power supply for DHW circulation pump

DHW circulation pumps with their own internal control units must be connected via a separate power supply. It is **not** permissible to use the power supply from the Vitotronic control unit or Vitotronic accessories.

Connection values of the function components

Component	Connected load [W]	Voltage [V]	Max. switching current [A]
Primary pump and control of well pump	200	230	4(2)
Secondary pump	130	230	4(2)
3-way diverter valve for central heating/DHW heating in conjunction with a cylinder loading system: Cylinder loading pump and 2-way shut-off valve	130	230	4(2)
Control of instantaneous heating water heater, stage 1 and 2	10	230	4(2)
Control of cooling	10	230	4(2)
Heating circuit pump A1/HC1 and M2/HC2	100	230	4(2)
DHW circulation pump	50	230	4(2)
Solar circuit pump	130	230	4(2)
Control of mixer motor, signal mixer CLOSE	10	230	0.2(0.1)
Control of mixer motor, signal mixer OPEN	10	230	0.2(0.1)
Total	Max. 1000		Max. 5(3) A

Control unit accessories

11.1 Overview

Accessories	Part no.	Vitocal				
		200-G	300-G	350-G	222-G	333-G
Photovoltaics, see from page 182						
Energy meter 1-phase	7506156	BWC-M 201.A			BWT-M 221.B	
Energy meter 3-phase	7506157	BWC 201.A	X	X	BWT 221.B	X
Remote control units, see from page 183						
Vitotrol 200-A	Z008341	X	X	X	X	X
Wireless remote control units, see from page 184						
Vitotrol 200-RF	Z011219	X	X	X	X	X
Wireless base station	Z011413	X	X	X	X	X
Wireless repeater	7456538	X	X	X	X	X

Control unit accessories (cont.)

Accessories	Part no.	Vitocal				
		200-G	300-G	350-G	222-G	333-G
Sensors, see from page 186						
Contact temperature sensor (NTC 10 kΩ)	7426463	X	X	X		
Immersion temperature sensor (NTC 10 kΩ)	7438702	X	X	X	X	X
Collector temperature sensor (NTC 20 kΩ)	7831913				X	X
Miscellaneous, see from page 187						
Contact relay	7814681	X	X	X	X	X
Phase monitor	7463720	X				
KM-BUS distributor	7415028	X	X	X	X	X
Swimming pool temperature controller, see from page 187						
Temperature controller for regulating swimming pool temperature	7009432	X	X	X	X	X
Extension for heating circuit control unit (controlled directly via the Vitotronic), see page 188						
Mixer extension kit	7441998	X	M2/HC2	M2/HC2	M2/HC2	M2/HC2
Extension for heating circuit control unit for heating circuit with mixer (control via the Vitotronic KM-BUS), see page 188						
Mixer extension kit (mixer mounting)	ZK02940	M2/HC2	M3/HC3	M3/HC3	M3/HC3	M3/HC3
Mixer extension kit (wall mounting)	ZK02941	M2/HC2	M3/HC3	M3/HC3	M3/HC3	M3/HC3
High limit safety cut-out	7197797	X	X	X		
Immersion thermostat	7151728	X	X	X	X	X
Contact thermostat	7151729	X	X	X	X	X
Solar DHW heating and central heating backup; see from page 191						
Solar control module type SM1	Z014470	X	X	X		
Function extensions, see from page 192						
AM1 extension	7452092	X	X	X	X	X
EA1 extension	7452091	X	X	X	X	X
Communication technology, see from page 193						
Vitocconnect 100, type OPTO2	ZK04789	X	X	X	X	X
Vitocom 100, type LAN1 with communication module	Z011224	X	X	X	X	X
Vitocom 300, type LAN3 with LON communication module	Z011399	X	X	X	X	X
LON communication module	7172173	X	X	X	X	X
LON communication module for cascade control	7172174		X	X		
LON cable for control unit data exchange	7134495	X	X	X	X	X
LON coupling, RJ45	7143496	X	X	X	X	X
LON plug-in connector, RJ45	7199251	X	X	X	X	X
LON socket, RJ45	7171784	X	X	X	X	X
Terminator	7143497	X	X	X	X	X

Note

- The following description of control unit accessories lists all functions and connections of each control unit accessory. The functions that are possible depend on the respective heat generator, see page 178.
- For further information on communication technology, see the "Data communication" technical guide.

11.2 Photovoltaics

Energy meter 1-phase

Part no. 7506156

With standard Modbus interface.

The Vitotronic control unit receives information via the Modbus detailing whether and how much (residual) energy is available to the heat pump from the photovoltaic system.

For optimised utilisation of the self-generated power from photovoltaic systems (own energy consumption), the following components and functions may be enabled by the Vitotronic control unit:

- Heat pump compressor.
- Heating of the DHW cylinder to the set DHW temperature or the second set DHW temperature.
- Heating the heating water buffer cylinder.
- Central heating
- Central cooling

Connection:

- Installation on 35 mm top-hat rail (as per EN 60715 TH35)
- Power cable cross-section: max. 6 mm²
- Control circuit cross-section: max. 2.5 mm²

Control unit accessories (cont.)

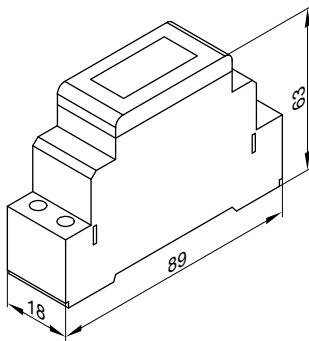

Specification

Single phase electricity meter

Rated voltage 230 V \sim -20 to +15 %

Rated frequency	50 Hz \sim -20 to +15 %
Current	
- Reference current	5 A
- Max. test current	32 A
- Starting current	20 mA
- Min. current	0.25 A
Power consumption	0.4 W actual power
Display	
- Actual power, voltage, current	LCD, 7-digit
- Count range	0 to 999999.9
- Pulses	2000 per kWh
- Accuracy categories	B as per EN 50470-3 1 as per IEC 62053-21
Permissible ambient temperature	
- Operation	-10 to +55 °C
- Storage and transport	-30 to +85 °C

Electricity meter, 3-phase

Part no. 7506157

With standard Modbus interface.

The Vitotronic control unit receives information via the Modbus detailing whether and how much (residual) energy is available to the heat pump from the photovoltaic system.

For optimised utilisation of the self-generated power from photovoltaic systems (own energy consumption), the following components and functions may be enabled by the Vitotronic control unit:

- Heat pump compressor.
- Heating of the DHW cylinder to the set DHW temperature or the second set DHW temperature.
- Heating the heating water buffer cylinder.
- Central heating
- Central cooling

Connection:

- Installation on top-hat rail 35 mm (to EN 60715 TH35)
- Main circuit cable cross-section: 1.5 to 16 mm²
- Control circuit cable cross-section: Max. 2.5 mm²

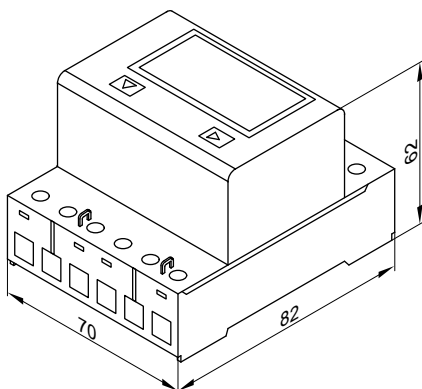

Specification

Rated voltage	3 x 230 V \sim /400 V \sim -20 to +15 %
Rated frequency	50 Hz \sim -20 to +15 %
Electricity	
- Reference current	10 A
- Max. measurable current	65 A
- Starting current	40 mA
- Min. current	0.5 A
Power consumption	0.4 W actual power per phase
Display	
- Per phase: Actual power, voltage, current	LCD, 7-digit, for 1 or 2 tariffs
- Count range	0 to 999999.9
- Pulses	100 per kWh
- Accuracy categories	B as per EN 50470-3 1 as per IEC 62053-21
Permissible ambient temperature	
- Operation	-10 to +55 °C
- Storage and transport	-30 to +85 °C

11.3 Remote control units

Information on Vitotrol 200-A

A Vitotrol 200-A can be used for each heating or cooling circuit. The Vitotrol 200-A can operate 1 heating/cooling circuit. Up to 3 remote control units can be connected to the control unit.

Note

Hardwired remote control units cannot be combined with the wireless base station.

Vitotrol 200-A

Part no. Z008341

KM-BUS subscriber

- Displays:
 - Room temperature
 - Outside temperature
 - Operating condition
- Party and economy mode can be enabled via keys
- Integral room temperature sensor for room temperature hook-up (only for one heating circuit with mixer)
- Settings:
 - Set room temperature for standard mode (normal room temperature)

Note

The set room temperature for reduced mode (reduced room temperature) is set at the control unit.

- Operating program

Installation location:

- Weather-compensated mode:
 - Installation anywhere in the building
- Room temperature hook-up:
 - The integral room temperature sensor captures the actual room temperature and effects any necessary correction of the flow temperature.

The captured room temperature depends on the installation site:

- Main living room on an internal wall opposite radiators
- Not on shelves or in recesses
- Never in the immediate vicinity of doors or close to heat sources (e.g. direct insolation, fireplace, TV set, etc.).

Connection:

- 2-core lead, length max. 50 m (even if connecting several remote control units)
- Never route this lead immediately next to 230/400 V cables
- LV plug as standard delivery

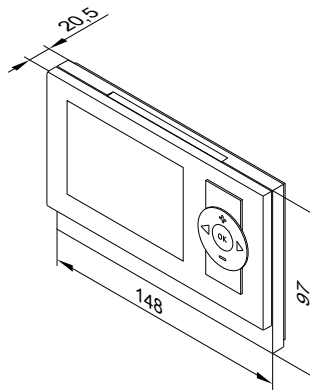

Specification

Power supply	Via KM-BUS
Power consumption	0.2 W
Protection class	III
IP rating	IP 30 to EN 60529; ensure through design/installation
Permissible ambient temperature	
– Operation	0 to +40 °C
– Storage and transport	-20 to +65 °C
Setting range of the set room temperature for standard mode	3 to 37 °C

Notes

- If the Vitotrol 200-A is to be used for room temperature hook-up, site the device in a main living room (lead room).
- Connect maximum 3 Vitotrol 200-A units to the control unit.

11.4 Wireless remote control units

Information on Vitotrol 200-RF

Wireless remote control unit with integral wireless transmitter for operation with the wireless base station.
 A Vitotrol 200-RF can be used for each heating or cooling circuit.
 The Vitotrol 200-RF can operate one heating/cooling circuit.
 Up to 3 wireless remote control units can be connected to the control unit.

Note

The wireless remote control unit **cannot** be combined with a hard-wired remote control.

Vitotrol 200-RF

Part no. Z011219

Wireless subscriber

- Displays:
 - Room temperature
 - Outside temperature
 - Operating condition
 - Wireless signal reception quality
- Settings:
 - Set room temperature for standard mode (normal room temperature)

Note

The set room temperature for reduced mode (reduced room temperature) is set at the control unit.

- Operating program

- Party and economy mode can be enabled via keys
- Integral room temperature sensor for room temperature hook-up (only for one heating circuit with mixer)

Installation location:

- Weather-compensated mode:
 - Installation anywhere in the building
- Room temperature hook-up:
 - The integral room temperature sensor captures the room temperature and effects any necessary correction of the flow temperature.

The captured room temperature depends on the installation site:

- Main living room on an internal wall opposite radiators
- Not on shelves or in recesses
- Never in the immediate vicinity of doors or close to heat sources (e.g. direct insolation, fireplace, TV set, etc.)

Control unit accessories (cont.)

Note

Observe the "Wireless accessories" technical guide.

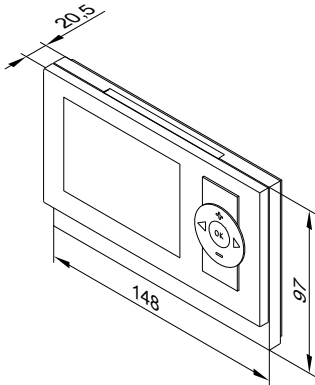

Specification

Power supply	2 AA batteries 3 V
Radio frequency	868 MHz
Wireless range	See "Wireless accessories" technical guide
Protection class	III
IP rating	IP 30 to EN 60529; ensure through design/installation
Permissible ambient temperature	
– Operation	0 to +40 °C
– Storage and transport	–20 to +65 °C
Setting range of the set room temperature for standard mode	3 to 37 °C

Wireless base station

Part no. Z011413

KM-BUS subscribers

- For communication between the Vitotronic control unit and Vitotrol 200-RF wireless remote control
- For up to 3 wireless remote control units. Not in conjunction with a hardwired remote control unit

Connection:

- 2-core lead: Length up to 50 m (even when connecting several KM-BUS subscribers)
- Never route this lead immediately next to 230 V/400 V cables.

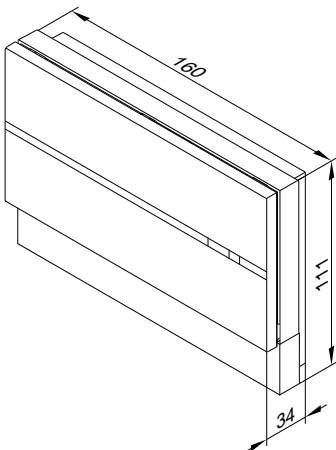

Specification

Power supply via KM-BUS	
Power consumption	1 W
Radio frequency	868 MHz
Protection class	III
IP rating	IP 20 to EN 60529, ensure through design/installation.
Permissible ambient temperature	
– Operation	0 to +40 °C
– Storage and transport	–20 to +65 °C

Wireless repeater

Part no. 7456538

Mains operated wireless repeater to increase the wireless range and for use in areas where wireless communication is difficult. Observe the "Wireless accessories" technical guide.

Do not use more than one wireless repeater per Vitotronic control unit.

- For preventing strongly diagonal angles of penetration of the radio signals through steel reinforced concrete ceilings/floors and/or multiple walls
- For circumventing large metallic objects situated between the wireless components.

5822541

Control unit accessories (cont.)

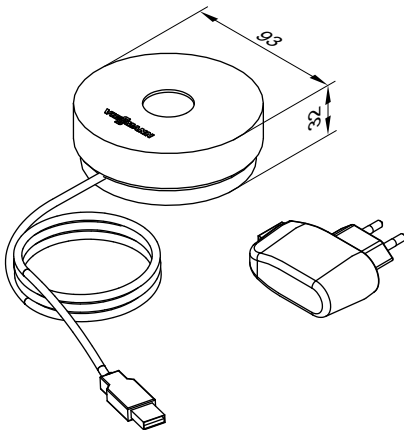

Specification

Power supply	230 V~/5 V _{DC} via plug-in power supply unit
Power consumption	0.25 W
Radio frequency	868 MHz
Lead length	1.1 m with plug
Safety category	II
IP rating	IP 20 to EN 60529; ensure through design/installation
Permissible ambient temperature	
– Operation	0 to +55 °C
– Storage and transport	–20 to +75 °C

11.5 Sensors

Contact temperature sensor

Part no. 7426463

To capture the temperature on a pipe

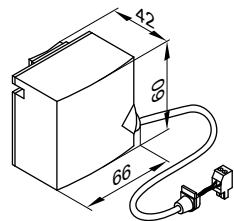

Secured with a tie.

Specification

Lead length	5.8 m, fully wired
IP rating	IP 32D to EN 60529; ensure through design/installation
Sensor type	Viessmann NTC 10 kΩ at 25 °C
Permissible ambient temperature	
– Operation	0 to +120 °C
– Storage and transport	–20 to +70 °C

Immersion temperature sensor

Part no. 7438702

To capture a temperature in a sensor well

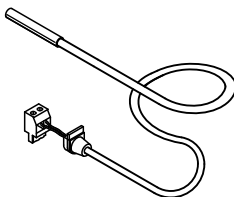

Specification

Lead length	5.8 m, fully wired
IP rating	IP 32 to EN 60529; ensure through design/installation.
Sensor type	Viessmann NTC 10 kΩ, at 25 °C
Permissible ambient temperature	
– Operation	0 to +90 °C
– Storage and transport	–20 to +70 °C

Collector temperature sensor

Part no. 7831913

Immersion temperature sensor for installation in the solar collector

- For systems with 2 collector arrays
- For heat statement (recording flow temperature)

On-site extension of the connecting lead:

- 2-core lead, length up to 60 m with a cross-section of 1.5 mm² (copper)
- Never route this lead immediately next to 230/400 V cables.

Specification

Lead length	2.5 m
IP rating	IP 32 to EN 60529; ensure through design/installation
Sensor type	Viessmann NTC 20 kΩ at 25 °C
Permissible ambient temperature	
– Operation	–20 to +200 °C
– Storage and transport	–20 to +70 °C

11.6 Miscellaneous

Contactor relay

Part no. 7814681

- Contactor in small enclosure
- With 4 N/C and 4 N/O contacts
- With terminal strips for earth conductors

Specification

Coil voltage	230 V/50 Hz
Rated current (I_{th})	AC1 16 A AC3 9 A

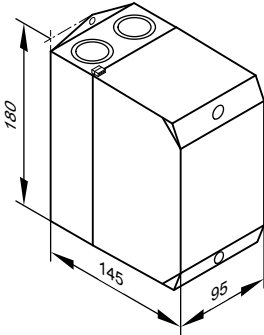

Phase monitor

Part no. 7463720

For monitoring the compressor power supply.

KM BUS distributor

Part no. 7415028

For connecting 2 to 9 devices to the KM BUS

Specification

Cable length	3.0 m, fully wired
IP rating	IP 32 to EN 60529; ensure through design/installation
Permissible ambient temperature	
– Operation	0 to +40 °C
– Storage and transport	-20 to +65 °C

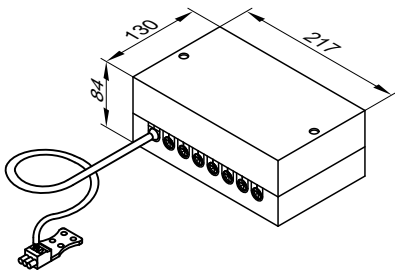

11.7 Swimming pool temperature control

Temperature controller for regulating the swimming pool temperature

Part no. 7009432

Specification

Connection	3-core lead with a cross-section of 1.5 mm ²
Setting range	0 to 35 °C
Switching differential	0.3 K
Breaking capacity	10(2) A, 250 V~
Switching function	with rising temperature from 2 to 3
Stainless steel sensor well	R 1/2 x 200 mm

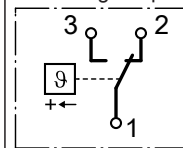
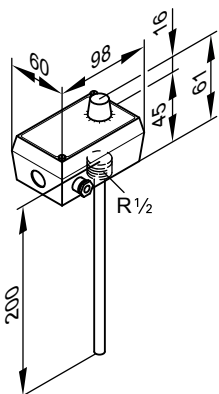

5822541

11.8 Heating circuit control unit extension

Direct control via the Vitotronic:

- Vitocal 200-G: For connecting an external heat generator
- Vitocal 300-G/350-G: For heating circuit with mixer M2/HC2 and for connecting an external heat generator
- Vitocal 333-G: For heating circuit with mixer M2/HC2

Mixer extension kit

Part no. 7441998

Components:

- Mixer motor with connecting cable (4.0 m long) for Viessmann mixer DN 20 to DN 50 and R 1/2 to R 1 1/4 (not for flanged mixers) and plug
- Flow temperature sensor as contact temperature sensor with connecting cable (5.8 m long) and plug
- Plug for heating circuit pump

Mixer motor

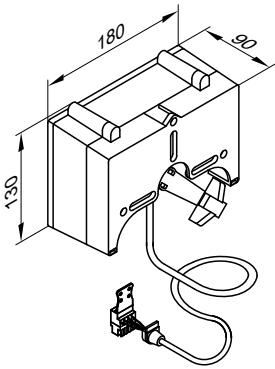

Mixer motor specification

Rated voltage	230 V~
Rated frequency	50 Hz
Power consumption	4 W
Safety category	II
IP rating	IP 42 to EN 60529; ensure through design/installation
Permissible ambient temperature	
– Operation	0 to +40 °C
– Storage and transport	–20 to +65 °C
Torque	3 Nm
Runtime for 90° <	120 s

Flow temperature sensor (contact temperature sensor)

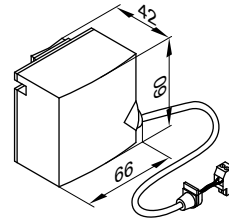

Secured with a tie.

Specification, flow temperature sensor

IP rating	IP 32D to EN 60529; ensure through design/installation
Sensor type	Viessmann NTC 10 kΩ at 25 °C
Permissible ambient temperature	
– Operation	0 to +120 °C
– Storage and transport	–20 to +70 °C

11.9 Heating circuit control unit extension

Control via the Vitotronic KM-BUS:

- Vitocal 200-G/222-G: For heating circuit with mixer M2/HC2
- Vitocal 300-G/350-G/333-G: For heating circuit with mixer M3/HC3

Mixer extension kit with integral mixer motor

Part no. ZK02940

KM-BUS subscribers

Components:

- Mixer PCB with mixer motor for Viessmann mixer DN 20 to DN 50 and R 1/2 to R 1 1/4
- Flow temperature sensor (contact temperature sensor)
- Plug for connecting the heating circuit pump
- Power cable (3.0 m long) with plug
- Bus connecting cable (3.0 m long) with plug

The mixer motor is mounted directly onto the Viessmann mixer DN 20 to DN 50 and R 1/2 to R 1 1/4.

Control unit accessories (cont.)

Mixer PCB with mixer motor

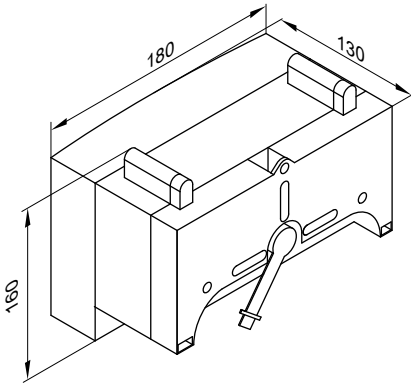

Specification, mixer PCB with mixer motor

Rated voltage	230 V~
Rated frequency	50 Hz
Rated current	2 A
Power consumption	5.5 W
IP rating	IP 32D to EN 60529; ensure through design/installation
Protection class	I
Permissible ambient temperature	
– Operation	0 to +40 °C
– Storage and transport	–20 to +65 °C
Rated breaking capacity of the relay output for heating circuit pump ^[20]	2(1) A, 230 V~
Torque	3 Nm
Runtime for 90° <	120 s

Mixer extension kit for separate mixer motor

Part no. ZK02941

KM-BUS subscribers

For connecting a separate mixer motor

Components:

- Mixer PCB for connecting a separate mixer motor
- Flow temperature sensor (contact temperature sensor)
- Plug for connecting the heating circuit pump and the mixer motor
- Power cable (3.0 m long) with plug
- Bus connecting cable (3.0 m long) with plug

Mixer PCB

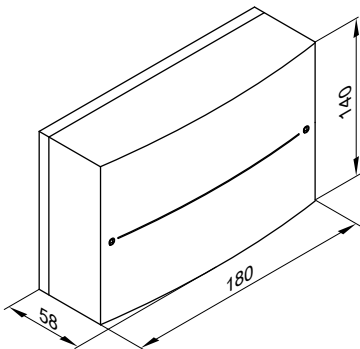

Flow temperature sensor (contact temperature sensor)

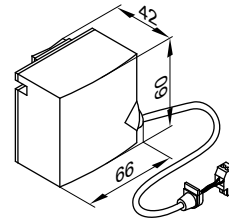

Secured with a tie.

Specification, flow temperature sensor

Cable length	2.0 m, fully wired
IP rating	IP 32D to EN 60529; ensure through design/installation
Sensor type	Viessmann NTC 10 kΩ at 25 °C
Permissible ambient temperature	
– Operation	0 to +120 °C
– Storage and transport	–20 to +70 °C

Specification mixer PCB

Rated voltage	230 V~
Rated frequency	50 Hz
Rated current	2 A
Power consumption	1.5 W
IP rating	IP 20D to EN 60529, ensure through design/installation
Protection class	I
Permissible ambient temperature	
– Operation	0 to +40 °C
– Storage and transport	–20 to +65 °C
Rated relay output breaking capacity	
– Heating circuit pump ^[20]	2(1) A, 230 V~
– Mixer motor	0.1 A, 230 V~
Required runtime of the mixer motor for 90° <	Approx. 120 s

Flow temperature sensor (contact temperature sensor)

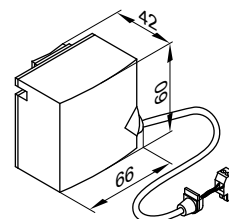

Secured with a tie.

Control unit accessories (cont.)

Specification, flow temperature sensor

Cable length	5.8 m, fully wired
IP rating	IP 32D to EN 60529; ensure through design/installation
Sensor type	Viessmann NTC 10 kΩ at 25 °C
Permissible ambient temperature	
– Operation	0 to +120 °C
– Storage and transport	–20 to +70 °C

High limit safety cut-out

Part no. 7197797

Note

Only use with heat pumps that reach a flow temperature of up to 65 °C.

If an external heat generator is connected in the secondary circuit, the high limit safety cut-out protects the heat pump refrigerant circuit from unacceptably high temperatures.

Examples of heat generators:

- Solar thermal systems
- Solid fuel boilers
- Non-modulating boilers

The high limit safety cut-out is connected to the control unit of the external heat generator. If the heat generator exceeds the temperature, it is switched off via the high limit safety cut-out.

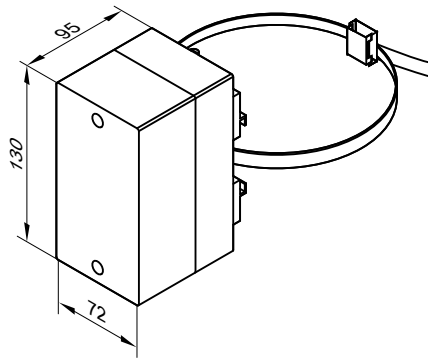

Specification, high limit safety cut-out

Connection	4.2 m, fully wired
Switching point	65 °C (cannot be changed)
Switching tolerance	+0/–6.5 K
IP rating	IP 41 to EN 60529; ensure through design/installation.
Ambient temperature	Max. 50 °C
Sensor temperature	Max. 90 °C
Sensor diameter	6.5 mm

Immersion thermostat

Part no. 7151728

May be used as a maximum temperature limiter for underfloor heating systems.

The temperature limiter is integrated into the heating flow. If the flow temperature is too high, the temperature limiter switches off the heating circuit pump.

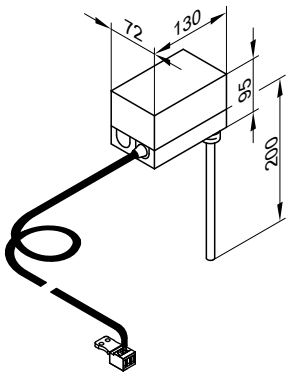

Specification

Cable length	4.2 m, fully wired
Setting range	30 to 80 °C
Switching differential	Max. 11 K
Breaking capacity	6(1.5) A, 250 V~
Setting scale	Inside the enclosure
Stainless steel sensor well (male thread)	R ½ x 200 mm
DIN reg. no.	DIN TR 1168

Contact thermostat

Part no. 7151729

May be used as a maximum temperature limiter for underfloor heating systems (only in conjunction with metal pipes).

The temperature limiter is integrated into the heating flow. If the flow temperature is too high, the temperature limiter switches off the heating circuit pump.

Control unit accessories (cont.)

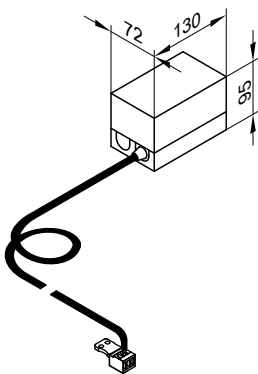

Specification

Lead length	4.2 m, fully wired
Setting range	30 to 80 °C
Switching differential	Max. 14 K
Breaking capacity	6(1.5) A, 250 V~
Setting scale	Inside the casing
DIN reg. no.	DIN TR 1168

11.10 Solar DHW heating and central heating backup

Solar control module, type SM1

Part no. Z014470

- Function extension inside wall mounting enclosure
- Electronic temperature differential control for dual mode DHW heating and central heating backup using solar collectors

Specification

Functions

- Output statement and diagnostic system
- Operation and display via the Vitotronic control unit.
- Switching the solar circuit pump
- Heating of 2 consumers via a collector array
- 2nd temperature differential control
- Thermostat function for reheating or utilising excess heat
- Speed control for solar circuit pump via PWM input (make: Grundfos and Wilo)
- Suppression of DHW cylinder reheating by the heat generator subject to solar yield
- Heat-up of the solar preheating stage (with 400 l DHW cylinders or larger)
- Collector safety shutdown
- Electronic temperature limitation in the DHW cylinder
- Switching of an additional pump or valve via relay

To implement the following functions, also order immersion temperature sensor, part no. 7438702:

- For DHW circulation diversion in systems with 2 DHW cylinders
- For return changeover between the heat generator and the heating water buffer cylinder
- For return changeover between the heat generator and the primary heat store
- For heating additional consumers

Structure

The solar control module contains:

- PCB
- Terminals:
 - 4 sensors
 - Solar circuit pump
 - KM BUS
 - Power supply (on-site ON/OFF switch)
- PWM output for switching the solar circuit pump
- 1 relay for switching one pump or one valve

Collector temperature sensor

For connection inside the appliance

On-site extension of the connecting lead:

- 2-core lead, length up to 60 m with a cross-section of 1.5 mm² (copper)
- Never route this lead immediately next to 230/400 V cables.

Collector temperature sensor specification

Lead length	2.5 m
IP rating	IP 32 to EN 60529; ensure through design/installation.
Sensor type	Viessmann NTC 20 kΩ at 25 °C
Permissible ambient temperature	
– Operation	–20 to +200 °C
– Storage and transport	–20 to +70 °C

Cylinder temperature sensor

For connection inside the appliance

On-site extension of the connecting lead:

- 2-core lead, length up to 60 m with a cross-section of 1.5 mm² (copper)
- Never route this cable immediately next to 230/400 V cables.

Cylinder temperature sensor specification

Lead length	3.75 m
IP rating	IP 32 to EN 60529; ensure through design/installation.
Sensor type	Viessmann NTC 10 kΩ at 25 °C
Permissible ambient temperature	
– Operation	0 to +90 °C
– Storage and transport	–20 to +70 °C

For systems with Viessmann DHW cylinders, the cylinder temperature sensor is installed in the threaded elbow in the heating water return (standard delivery or accessory for the relevant DHW cylinder).

Control unit accessories (cont.)

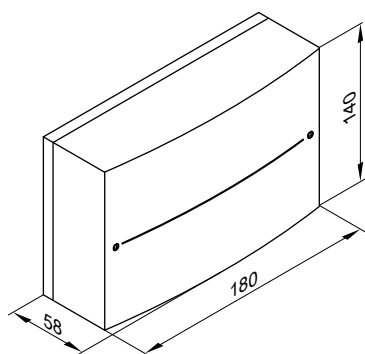

Protection class	I
IP rating	IP 20 to EN 60529; ensure through design/installation.
Function type	Type 1B to EN 60730-1
Permissible ambient temperature	
– Operation	0 to +40 °C, use in the living space or boiler room (standard ambient conditions)
– Storage and transport	–20 to +65 °C
Rated relay output breaking capacity	
– Semi-conductor relay 1	1 (1) A, 230 V~
– Relay 2	1 (1) A, 230 V~
– Total	Max. 2 A

Solar control module specification

Rated voltage	230 V~
Rated frequency	50 Hz
Rated current	2 A
Power consumption	1.5 W

11.11 Function extensions

AM1 extension

Part no. 7452092

Function extension inside a casing, for wall mounting.

Using the extension allows the following functions to be achieved:

- Cooling via coolant buffer cylinder
- or
 - Central fault message
- Coolant buffer cylinder heat transfer.
- Primary source changeover in conjunction with ice store.

Specification

Rated voltage	230 V~
Rated frequency	50 Hz
Rated current	4 A
Power consumption	4 W
Rated relay output breaking capacity	2(1) A, 250 V~ each, total max. 4 A~
Safety category	I
IP rating	IP 20 D to EN 60529, ensure through design/installation
Permissible ambient temperature	
– Operation	0 to +40 °C Installation in living spaces or boiler rooms (standard ambient conditions)
– Storage and transport	–20 to +65 °C

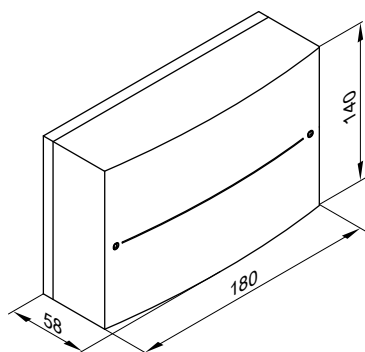

EA1 extension

Part no. 7452091

Function extension inside a casing, for wall mounting.

Using the inputs and outputs allows up to 5 functions to be implemented.

1 analogue input (0 to 10 V):

- Default set flow temperature, secondary circuit.

3 digital inputs:

- External changeover of the operating state.
- External demand and blocking.
- External demand for a minimum heating water temperature.

1 switching output:

- Swimming pool heating control.

Control unit accessories (cont.)

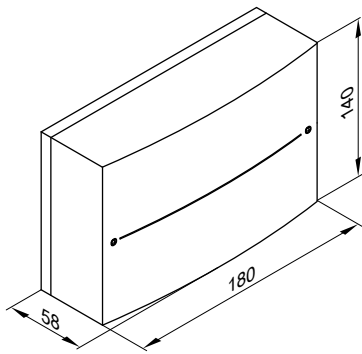

Specification

Rated voltage	230 V~
Rated frequency	50 Hz
Rated current	2 A
Power consumption	4 W
Rated breaking capacity of the relay output	2(1) A, 250 V~
Safety category	I
IP rating	IP 20 D to EN 60529, ensure through design/installation
Permissible ambient temperature	
– Operation	0 to +40 °C Installation in living spaces or boiler rooms (standard ambient conditions)
– Storage and transport	–20 to +65 °C

11.12 Communication technology

Note

For further information about communication technology, see "Data communication" technical guide

Vitoconnect, type OPTO2

Part no. ZK04789

- Internet interface for remote control of a heating system with 1 heat generator via WiFi with DSL router
- Compact device for wall mounting
- For system operation with **ViCare app** and/or **Vitoguide**

Functions when operating with the ViCare app

- Calling up the temperatures of connected heating circuits
- Intuitive adjustment of preferred temperatures and time programs for central heating and DHW heating
- Easy transmission of system data, e.g. fault messages via email or telephone communication with the heating contractor
- Heating system fault reporting by push notification

The ViCare app supports mobile devices with the following operating systems:

- Apple iOS
- Google Android

Note

- **Compatible versions:** Visit the App Store or Google Play.
- **Further information:** Visit www.vicare.info

Functions when operating with Vitoguide

- Monitoring of heating system following service clearance by the system user
- Access to operating programs, set values and time programs
- Retrieving system information for all connected heating systems
- Display and forwarding of fault messages in plain text

Vitoguide supports the following end devices:

- Mobile devices with a screen size of 8 inches or larger

Note

Further information: Visit www.vitoguide.info

On-site requirements

- Compatible heating systems with Vitoconnect, type OPTO2

Note

Supported control units: Visit www.viessmann.de/vitoconnect

- Before commissioning, check the system requirements for communication via local IP networks/WiFi.

- Port 443 (HTTPS) and port 123 (NTP) must be open.
- The MAC address is printed on the device label.
- Internet connection with flat rate data (**without time or volume restrictions**)

Installation location

- Installation type: Wall mounting
- Installation only in enclosed buildings
- The installation location must be dry and free of frost.
- Distance to heat generator min. 0.3 m and max. 2.5 m
- Standard socket 230 V/50 Hz
or
US/CA: Socket 120 V/60 Hz
max. 1.5 m to installation location
- Internet access with adequate WiFi signal

Note

The WiFi signal strength can be increased with commercially available WiFi repeaters.

Standard delivery

- Web interface for wall mounting
- Power cable with plug-in power supply unit (1.5 m long)
- Connecting cable with Optolink/USB (WiFi module/boiler control unit, 3 m long)

Control unit accessories (cont.)

Specification

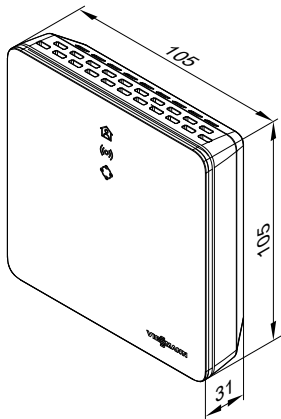

Plug-in power supply unit specification

Rated voltage	100 to 240 V~
Rated frequency	50/60 Hz
Output voltage	12 V $\overline{\text{DC}}$
Output current	1 A
Protection class	II
Permissible ambient temperature	
– Operation	5 to +40 °C Installation in living spaces or boiler rooms (standard ambient conditions)
– Storage and transport	–20 to +60 °C

Vitoconnect specification

Rated voltage	12 V $\overline{\text{DC}}$
WiFi frequency	2.4 GHz
WiFi encryption	Unencrypted or WPA2
Frequency band	2400.0 to 2483.5 MHz
Max. transmitting power	0.1 W (e.i.r.p.)
Internet protocol	IPv4
IP assignment	DHCP
Rated current	0.5 A
Power consumption	5.5 W
Protection class	III
IP rating	IP 20D to EN 60529
Permissible ambient temperature	
– Operation	5 to +40 °C Installation in living spaces or boiler rooms (standard ambient conditions)
– Storage and transport	–20 to +60 °C

Keyword index

A

AC-Box.....	128, 172
AC-Box, connection accessories.....	129
Accessories, DHW heating.....	120
Active cooling.....	128, 170, 172
AM1 extension.....	192
Aperture area.....	132
Application limits	
– 200-G.....	12
– 222-G.....	62
– 300-G.....	28, 43
– 333-G.....	76
– 350-G.....	51
Application procedure (details).....	135
Automatic thermostatic mixing valve.....	161, 162
Auxiliary function.....	178

B

BDF valve.....	171
Brine manifold.....	92

C

Cable length.....	141, 142
Check valve.....	161, 162
Circulation pump for cylinder loading.....	118
CO ₂ equivalent.....	176
Coil surface area.....	162
Cold water.....	60, 61, 74, 75
Collector circuit.....	132
Collector temperature sensor.....	134, 186
Communication module, communication.....	143
Compressor	
– Power cable.....	141, 142
Connections.....	59, 73
Connection set, DHW circulation.....	97
Contact temperature sensor.....	130, 186
Contact thermostat.....	190
Coolant.....	155
Cooling curve.....	178
– Level.....	180
– Slope.....	180
Cooling function	
– Active cooling.....	172
– Natural cooling.....	170
Cooling limit.....	178
Cooling mode.....	170
Cooling with an underfloor heating system.....	171

D

Data communication.....	179
Delivered condition	
– Vitocal 200-G.....	7
– Vitocal 300-G.....	21, 39
– Vitocal 350-G.....	47
DHW.....	60, 61, 74, 75
DHW circulation.....	60, 61, 74, 75
DHW circulation connection set.....	97
DHW circulation pump.....	161, 162
DHW cylinder.....	161
DHW demand.....	144
DHW heating.....	175
– Connection on the DHW side.....	161
– Selecting a cylinder loading cylinder.....	165
– Selecting a DHW cylinder.....	162
– Selecting a plate heat exchanger.....	168
DHW side connection.....	161
DHW temperature.....	178
Diagnostic system.....	178
Dimensions.....	59, 73
– Vitocal 200-G.....	11
– Vitocal 222-G.....	60
– Vitocal 300-G.....	26, 27, 42
– Vitocal 333-G.....	74
– Vitocal 350-G.....	50
Diverter valve.....	130
Double U-shaped pipe probe.....	149
Drain valve.....	162
Drinking water filter.....	162

E

EA1 extension.....	192
Economy mode.....	178
Electrical connections.....	138
Electrical demand.....	135
Electrical values.....	58, 72
Electrical values, heat pump.....	58, 72
Electricity meter.....	138
Energy efficiency class.....	59, 73
EnEV.....	179
Ethylene glycol.....	145
Expansion vessel.....	90
– Primary circuit.....	151
– Solar.....	176
– Solar expansion vessel.....	175
– Structure, function, specification.....	176
– Volume calculation.....	176
Extended menu.....	177
External demand.....	178
External heat generator.....	145
External hook-up.....	178

Keyword index

- F**
- Fault..... 178
 - Federal tariffs [Germany]..... 135
 - Fill water..... 160
 - Finished floor..... 137
 - Flanged aperture..... 118
 - Flange hood..... 118
 - Flow
 - Cooling circuit..... 171
 - Primary circuit..... 60, 61, 74, 75, 171
 - Secondary circuit..... 60, 61, 74, 75
 - Flow rate..... 154
 - Flow regulating valve..... 161, 162
 - Flow temperature..... 178
 - Freshwater module..... 120
 - Frost protection..... 145, 178
 - Frost protection function..... 180
 - Function description
 - DHW heating..... 161
 - Instantaneous heating water heater..... 144
- G**
- Geothermal collector
 - Manifolds and headers..... 146
 - Sizing..... 148
 - Geothermal probe
 - Pressure drop..... 151
 - Sizing..... 151
 - Groundwater..... 153
- H**
- Heat exchanger, primary circuit..... 154
 - Heating circuit and heat distribution..... 156
 - Heating curve..... 178
 - Level..... 180
 - Slope..... 180
 - Heating lance..... 118, 167
 - Heating limit..... 178
 - Heating output..... 143
 - Heating performance data..... 59, 73
 - Heating water..... 58, 72
 - Heating water buffer cylinder..... 157
 - Connected in parallel..... 157
 - Connected in series..... 158
 - Sizing for runtime optimisation..... 157
 - Heating water flow temperature..... 156
 - Heat load..... 143
 - Heat pump cascade..... 143
 - Heat pump control unit..... 141, 142
 - Design..... 177
 - Functions..... 177, 178
 - Languages..... 178
 - PCBs..... 177
 - Programming unit..... 177
 - Standard modules..... 177
 - Heat pump sizing..... 143
 - Heat transfer medium..... 93, 153
 - Help text..... 177
 - High limit safety cut-out for solar thermal system..... 134
 - Holiday program..... 178
 - Hook-up..... 178
 - Hydraulic conditions, secondary circuit..... 157
 - Hydraulic connection..... 142
 - Cylinder loading system..... 166
 - DHW cylinder..... 163
 - Hydraulic terminal area..... 162
- I**
- Immersion heater..... 108, 118, 123
 - Immersion thermostat..... 190
 - Impressed current anode..... 109, 126
 - Information..... 178
 - Installation accessories
 - Primary circuit..... 86
 - Secondary circuit..... 82, 94
 - Instantaneous heating water heater..... 58, 72, 94, 144
 - Power cable..... 141, 142
 - Intended use..... 177
- K**
- KM BUS distributor..... 187
- L**
- Lag heat pump..... 143
 - Leak detection..... 176
 - LON module..... 143
- M**
- Manifold
 - For 2 Divicons..... 101
 - For 3 Divicons..... 102
 - Mechanical central ventilation systems..... 85
 - Mechanical ventilation systems..... 85
 - Minimum clearance..... 137
 - Minimum clearances..... 135
 - Minimum flow rate..... 157, 160
 - Minimum heating system volume..... 160
 - Minimum pipe diameters..... 160
 - Minimum room height..... 137
 - Minimum system volume..... 157
 - Mixer extension
 - Integral mixer motor..... 188
 - Separate mixer motor..... 189
 - Mixer extension kit
 - Integral mixer motor..... 188
 - Separate mixer motor..... 189
 - Mono energetic operation..... 144
 - Mono mode operation..... 143
 - Motorised ball valve..... 119, 130
- N**
- Natural cooling..... 127, 170
 - Navigation..... 177
 - NC-Box..... 127, 170
 - Non-return valve..... 162
- O**
- Operating mode
 - Dual mode..... 145
 - Operating pressure..... 58, 72
 - Operating program..... 178
 - Operating status..... 178
 - Operation
 - Mono energetic..... 144
 - Mono mode..... 143
 - Output diagrams
 - Vitocal 200-G..... 13, 18
 - Vitocal 222-G..... 62
 - Vitocal 300-G..... 29, 44
 - Vitocal 333-G..... 76
 - Vitocal 350-G..... 52
 - Outside temperature sensor..... 180
 - Oversizing..... 143
 - Overview
 - Control unit accessories..... 181
 - Installation accessories..... 82

Keyword index

P

Party mode.....	178
Performance data.....	58, 72
Permiss. operating pressure.....	59, 73
Pipe separator.....	162
Plain text display.....	177
Planning aids.....	158
Platform for unfinished floors.....	126, 137
Potable water softening system.....	160
Power consumption.....	58, 72
Power-OFF.....	135, 138, 141, 142, 143
Power-OFF period.....	135
Power-OFF time.....	143
Power supply.....	135
– Recommended power cables.....	141, 142
Power tariffs.....	135
Pressure drop	
– Vitocal 300-G.....	29, 44
– Vitocal 350-G.....	52
Pressure drop diagram	
– 3-way diverter valve.....	124
Pressure drop in pipes.....	151
Pressure gauge connection.....	162
Pressure points.....	137
Pressure reducer.....	162
Primary source	
– Brine.....	145
– Groundwater/coolant.....	153
Product information	
– Vitocal 200-G.....	7
– Vitocal 222-G.....	56
– Vitocal 300-G.....	21, 39
– Vitocal 333-G.....	70
Product types.....	6
Pump anti-seizing protection.....	178
Pump output supplements.....	153

R

Recommended power cable.....	142
Recommended power cables.....	141
Refrigerant circuit.....	58, 72
Residual heads	
– Vitocal 200-G.....	13, 18
– Vitocal 222-G.....	62
– Vitocal 300-G.....	34
– Vitocal 333-G.....	76
Return	
– Cooling circuit.....	171
– Primary circuit.....	60, 61, 74, 75
– Secondary circuit.....	60, 61, 74, 75, 171
Return well.....	154
Room height.....	137
Room temperature.....	178
Room temperature sensor	
– Cooling circuit.....	130
Room temperature sensor for cooling operation.....	170, 172
Runtime optimisation.....	157

S

Safety equipment block.....	96
Safety valve.....	161, 162
Screed drying.....	178
Seasonal performance factor.....	156
Secondary circuit.....	157
Settings.....	178
Siting.....	135
Sizing	
– Heating water buffer cylinder.....	157
Sizing for bridging power-OFF periods.....	157
Sizing the heat pump.....	143
Solar central heating backup.....	175
Solar circuit pump.....	132
Solar collectors.....	175
Solar control module.....	175, 178, 191
– Specification.....	192
Solar DHW heating.....	175
Solar Divicon.....	132
Solar expansion vessel.....	176
Solar heat exchanger set.....	109, 131
Solar swimming pool heating.....	175
Solar thermal system.....	175
Sound power.....	58, 72, 73
Sound power level.....	59, 73
Specification	
– Solar control module.....	191, 192
– Vitocal 300-G.....	23, 40, 41, 48, 49
– Vitocal 333-G.....	72
Standard delivery	
– Vitocal 200-G.....	7
– Vitocal 300-G.....	21, 39
– Vitocal 350-G.....	47
Standard heat load of the building.....	143
Supplement for DHW heating.....	144
Supplement for setback mode.....	144
Supply well.....	154
System separation.....	154

T

Technical connection requirements.....	138
Temperature limit.....	178
Temperature sensor	
– Contact temperature sensor.....	130, 186
– Outside temperature sensor.....	180
Thermostat	
– Contact temperature.....	190
– Immersion temperature.....	190
Three-way diverter valve.....	124
– Pressure drop diagram.....	124
Tightness test.....	176
Time program.....	178
Time switch.....	179
Top-up water.....	160
Total weight.....	58, 59, 72, 73, 137
Transport aid.....	126
Tundish set.....	126
Tyfocor.....	153

U

Underfloor heating.....	171
-------------------------	-----

Keyword index

V

Ventilation.....	85
Ventilation units.....	85
Vitoconnect 100.....	193
Vitotrol	
– 200-A.....	184
– 200-RF.....	184
Vitovent.....	85
Vitovent 200-C.....	85
Vitovent 300-C.....	85
Vitovent 300-F.....	85
Vitovent 300-W.....	85
Volumes in pipes.....	152

W

Wall clearance.....	137
Wall clearances.....	135
Warning.....	178
Water quality.....	160
Weather-compensated control.....	178
Weather-compensated control unit	
– Frost protection function.....	180
– Operating programs.....	179
Weight.....	59, 73, 137
Wireless components	
– Wireless base station.....	185
– Wireless remote control.....	184
– Wireless repeater.....	185

Subject to technical modifications.

Viessmann Werke GmbH & Co. KG
D-35107 Allendorf
Telephone: +49 6452 70-0
Fax: +49 6452 70-2780
www.viessmann.com

Viessmann Limited
Hortonwood 30, Telford
Shropshire, TF1 7YP, GB
Telephone: +44 1952 675000
Fax: +44 1952 675040
E-mail: info-uk@viessmann.com