

Immersion heater EHE

6 kW and 12 kW
For installation in DHW cylinders

For applicability, see the last page

Immersion heater EHE

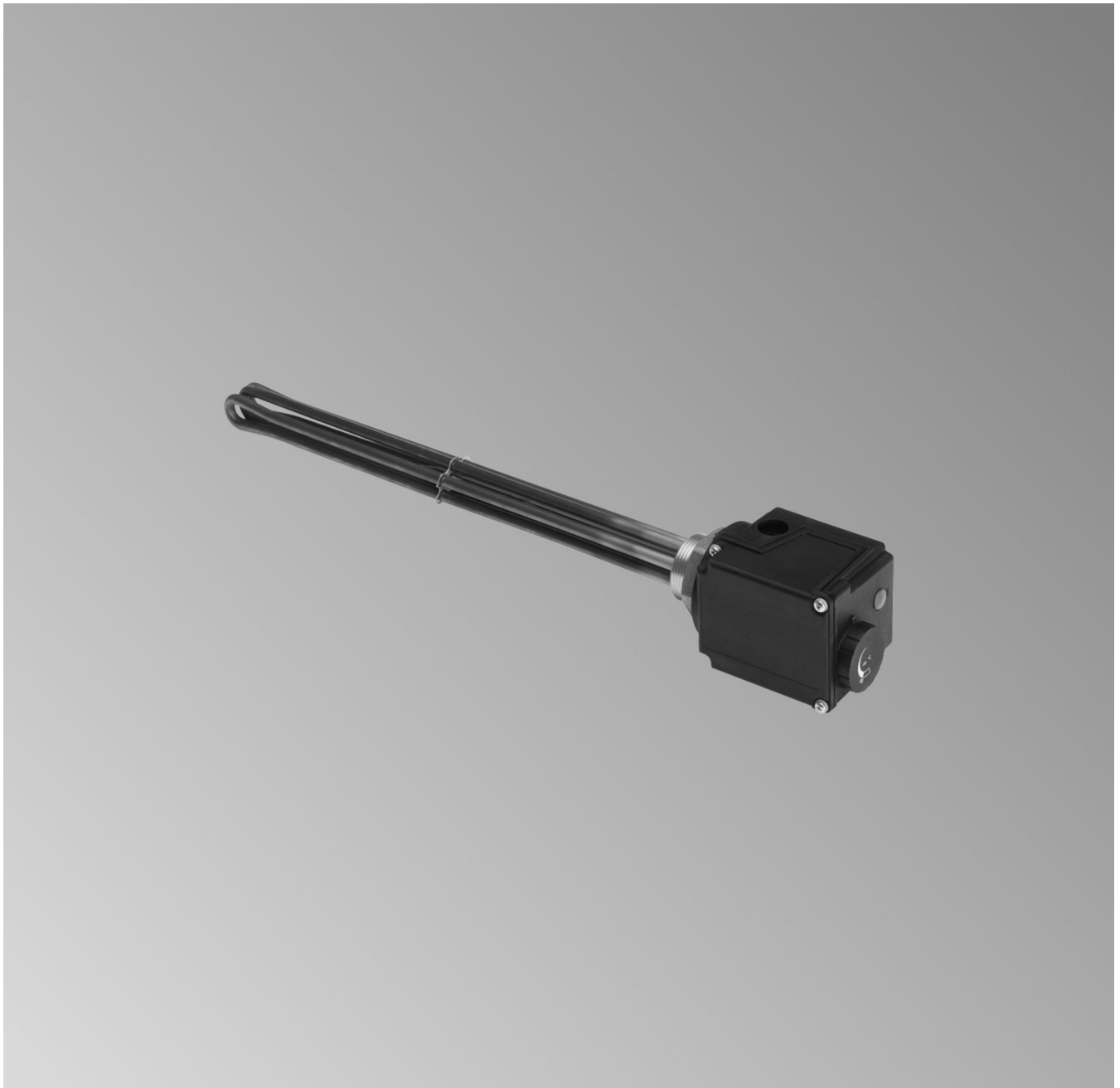

Safety instructions

Safety instructions



Please follow these safety instructions closely to prevent accidents and material losses.

Safety instructions explained



Danger

This symbol warns against the risk of injury.



Please note

This symbol warns against the risk of material losses and environmental pollution.

Note

Details identified by the word "Note" contain additional information.

Target group

These instructions are exclusively intended for qualified contractors.

- Work on electrical equipment may only be carried out by a qualified electrician.
- The system must be commissioned by the system installer or a qualified person authorised by the installer.

Regulations to be observed

- National installation regulations
- Statutory regulations for the prevention of accidents
- Statutory regulations for environmental protection
- Codes of practice of the relevant trade associations
- All relevant safety regulations as defined by DIN, EN, DVGW, VDE and locally applicable standards
 - Ⓐ ÖNORM, EN and ÖVE
 - Ⓒ SEV, SUVA, SVTI, SWKI and SVGW

Working on the system

- Isolate the system from the power supply (e.g. by removing the separate fuse or by means of a mains isolator) and check that it is no longer live.
- Safeguard the system against reconnection.



Please note

Electronic assemblies can be damaged by electrostatic discharge. Prior to commencing any work, touch earthed objects such as heating or water pipes to discharge static loads.



Danger

Hot surfaces can cause burns.

- Before maintenance and service work, switch OFF the appliance and let it cool down.
- Never touch the hot surfaces of uninsulated pipes and fittings.

Repair work



Please note

Repairing components that fulfil a safety function can compromise the safe operation of the system. Replace faulty components only with genuine Viessmann spare parts.

Safety instructions (cont.)**Auxiliary components, spare and wearing parts**

- !** **Please note**
Spare and wearing parts that have not been tested together with the system can compromise its function. Installing non-authorized components and making non-approved modifications or conversions can compromise safety and may invalidate our warranty.
For replacements, use only original spare parts supplied or approved by Viessmann.

Index

1. Product information	Intended use	5
	Product information	5
2. Installation sequence	Fitting the immersion heater EHE	6
	Power supply	6
	Connecting the earth conductor to the DHW cylinder	8
3. Commissioning and adjustment	Commissioning	10
	Instructing the system user	10
4. Maintenance	Maintenance and service	11
5. Troubleshooting	High limit safety cut-out has responded	12
6. Certificates	Declaration of conformity	13

Intended use

This appliance may only be used for auxiliary domestic hot water heating in sealed unvented vessels (DHW cylinders). Due to its design, the appliance may only be installed and operated in a horizontal position. When operational, the heating rods and sensor tube must be completely surrounded by domestic hot water on all sides. Do not impede the natural thermal water flow. The technical limits specified in these instructions must be observed.

The appliance is only intended to be installed and operated in sealed unvented systems that comply with EN 12 828/DIN 1988, with due attention paid to the associated installation, service and operating instructions. DHW cylinders are exclusively designed to hold fill water of potable quality.

Intended use presupposes that a fixed installation in conjunction with permissible, system-specific components has been carried out.

Commercial or industrial use for purposes other than domestic hot water heating shall be deemed inappropriate.

Any usage beyond this must be approved by the manufacturer in each individual case.

Incorrect usage or operation of the appliance (e.g. the appliance being opened by the system user) is prohibited and will result in an exclusion of liability.

Incorrect usage also occurs if the components in the system are modified from their intended function.

Adhere to statutory regulations, especially concerning the hygiene of potable water.

Product information

Immersion heater EHE

- Compliant with EN 60335-1 (VDE 0700-1), VDE 0700-253 and respective country-specific standards, e.g. ÖVE and SEV
- For heating domestic hot water

Note

Only use the immersion heater EHE with very soft to medium hard water up to 2.5 mol/m³ (14 °dH).

- Max. ambient temperature at the casing: 35 °C
- Unheated section: approx. 130 mm from sealing face
- For installation in a DHW cylinder under the following conditions:
 - Min. 200 l water content
 - Water inlet and outlet pipes must be made of metal.
 - All metal parts that come into contact with water must be permanently and securely connected to the earth conductor.
- The safety valve must be installed in accordance with the installation instructions of the manufacturer and of the DHW cylinder.
- Temperature controller:
 - **Note**
To prevent rapid scale build-up on the immersion heater EHE, we recommend setting the temperature controller to max. 60 °C (marking on the rotary selector).
 - Setting range of the temperature controller: approx. 34 to 75 °C.
 - Temperature in frost protection mode: approx. 10 °C.
 - Start-up: approx. 34 °C.



Please note

Temperatures above 90 °C will trigger the high limit safety cut-out of the immersion heater EHE. When using the immersion heater EHE in a DHW cylinder with integral indirect coil, limit the temperature introduced by the indirect coil to 90 °C.

Minimum clearance

- When siting the DHW cylinder, ensure there is sufficient clearance to install the immersion heater EHE.
- Allow for the installed length of the immersion heater EHE plus 150 mm.



DHW cylinder installation instructions

Fitting the immersion heater EHE

Note

The heating rods and sensor tube of the immersion heater EHE must not come into contact with each other.

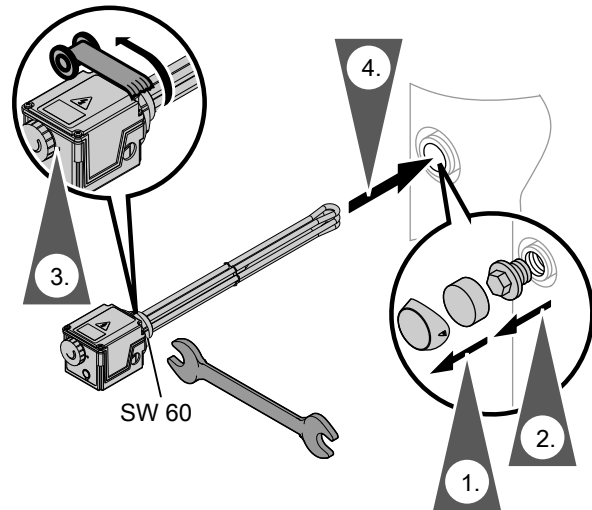

Fig. 1

Power supply

Isolators for non-earthed conductors:

Install an isolator in the power cable to provide omnipolar separation from the mains for all active conductors, corresponding to overvoltage category III (3 mm) for full isolation. The isolator must be fitted in the permanent electrical installation, in line with installation requirements.

Danger Incorrectly executed electrical installations can result in injuries from electrical current and damage to the appliance.

Connect the power supply and implement all safety measures (e.g. RCD circuit) in accordance with the following regulations:

- IEC 60364-4-41
- VDE regulations
- Technical connection requirements specified by the local power supply utility

Danger The absence of component earthing can lead to serious injury from electric current if an electrical fault occurs. The appliance and pipework must be connected to the equipotential bonding of the building.

Danger Incorrect core assignment can result in serious injury and damage to the appliance. Never interchange cores "L" and "N".

Recommended power cable: H05V2V2-F

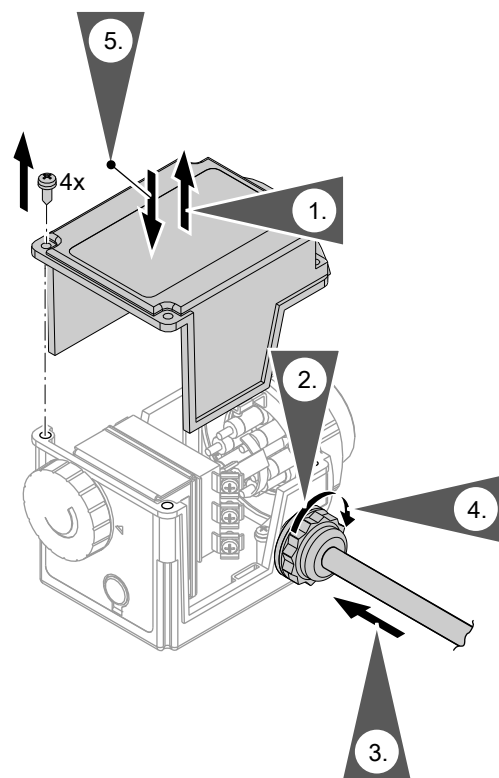



Fig. 2

1. Open the casing.
2. Mount the cable fitting (supplied inside the casing).

Power supply (cont.)

3. Feed cable H05V2V2-F through the cable fitting and make the electrical connection.
The immersion heater EHE can be operated at 3 output stages.
The output is determined by the type of connection.
Make the mains connection for the immersion heater EHE as 6 kW and 12 kW respectively, as detailed in the tables below.

5. **Danger**  An electrical fault causing serious injury may result if the casing is not securely sealed. Only use the washers, screws and casing seal supplied. Never move or damage the casing seal when closing the casing.

Close the casing.

4. Apply strain relief to the cable.

Immersion heater EHE 6 kW

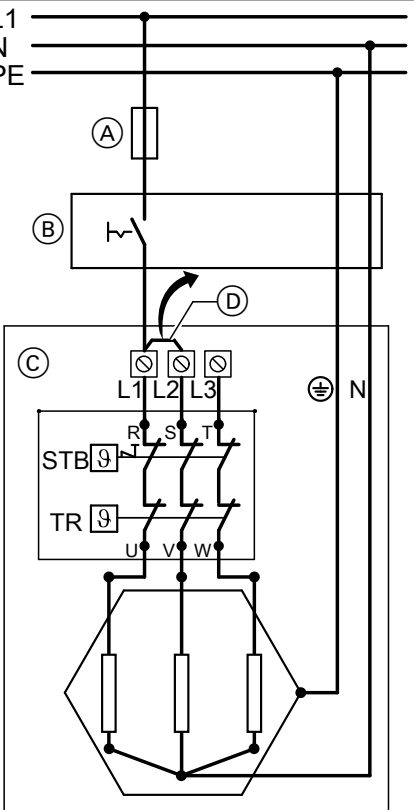
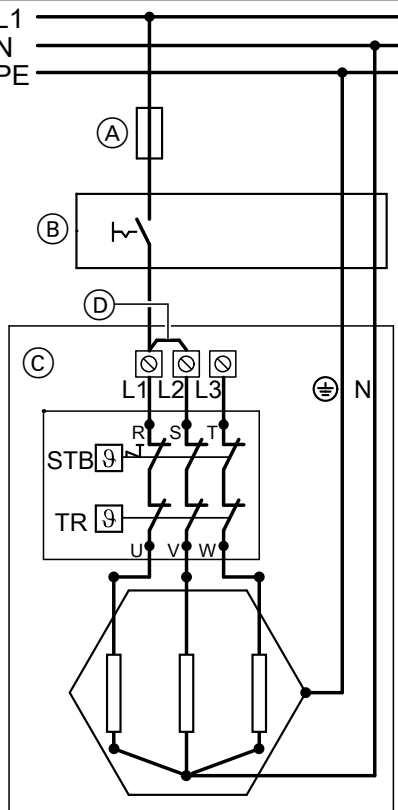
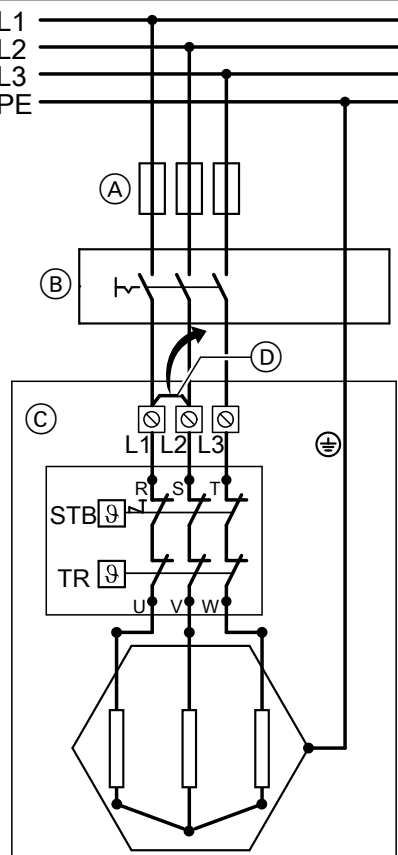
2 kW heating output connection:	4 kW heating output connection:	6 kW heating output connection:
1/N/PE 230 V~	1/N/PE 230 V~	3/PE 400 V~
		
<p>Note Remove jumper (D) when making this connection.</p>		<p>Note Remove jumper (D) when making this connection.</p>
<p>(A) On-site fuse/MCB, output-dependent (B) 3-pole switch (on-site) (C) Immersion heater EHE (D) Remove jumper (standard delivery)</p>	<p>(A) On-site fuse/MCB, output-dependent (B) 3-pole switch (on-site) (C) Immersion heater EHE (D) Jumper (standard delivery)</p>	<p>(A) On-site fuses/MCBs, output-dependent (B) 3-pole switch (on-site) (C) Immersion heater EHE (D) Remove jumper (standard delivery)</p>

Power supply (cont.)

Immersion heater EHE 12 kW

4 kW heating output connection:
2/PE 400 V~

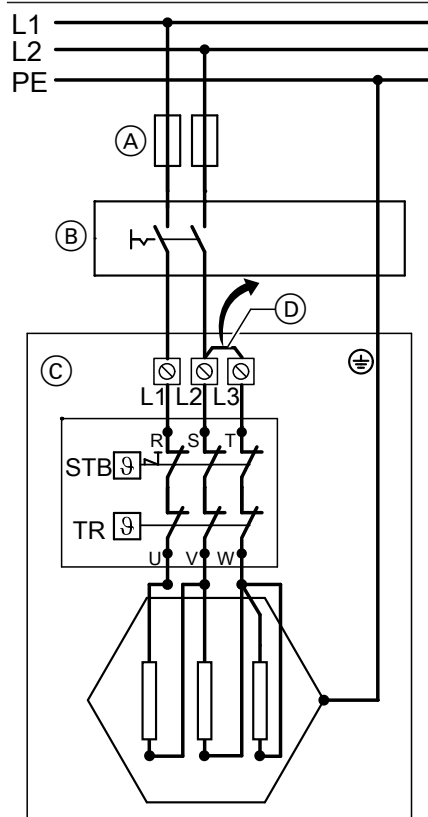

Note
Remove jumper (D) when making this connection.

- (A) On-site fuses/MCBs, output-dependent
- (B) 3-pole switch (on-site)
- (C) Immersion heater EHE
- (D) Remove jumper (standard delivery)

8 kW heating output connection:
2/PE 400 V~

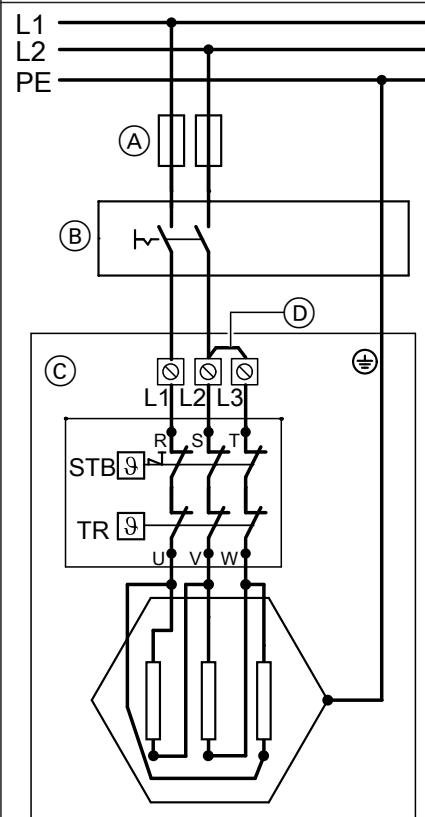

Note
Remove jumper (D) when making this connection.

- (A) On-site fuses/MCBs, output-dependent
- (B) 3-pole switch (on-site)
- (C) Immersion heater EHE
- (D) Jumper (standard delivery)

12 kW heating output connection:
3/PE 400 V~

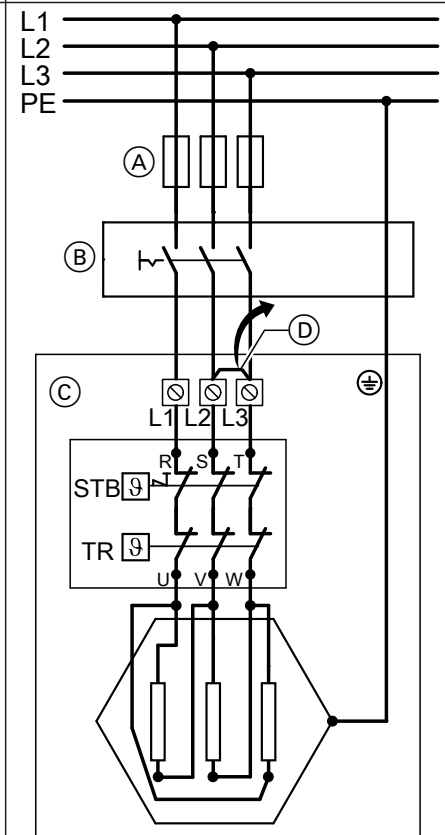

Note
Remove jumper (D) when making this connection.

- (A) On-site fuses/MCBs, output-dependent
- (B) 3-pole switch (on-site)
- (C) Immersion heater EHE
- (D) Remove jumper (standard delivery)

Connecting the earth conductor to the DHW cylinder

Danger
The absence of component earthing can lead to serious injury from electric current if an electrical fault occurs.
The appliance and pipework must be connected to the equipotential bonding of the building.

- The water inlet and outlet pipes of the DHW cylinder must be made of metal.
- All metal parts that come into contact with water must be permanently and securely connected to the earth conductor.

 DHW cylinder installation instructions

In line with VDE requirements and applicable standards, connect the inner metal cylinder body securely and permanently to the earth conductor with a serrated lock washer.

Connecting the earth conductor to the DHW... (cont.)

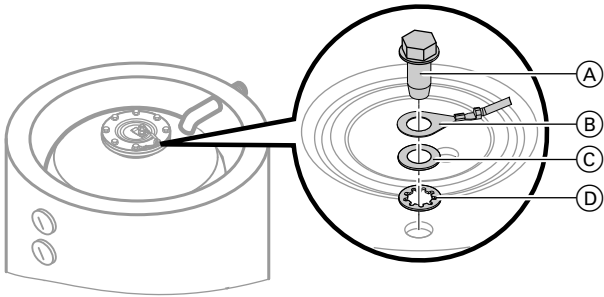

Fig. 3

- (A) Screw (with washer)
- (B) Lug for earth conductor
- (C) Washer
- (D) Serrated lock washer

Commissioning

Note

Only switch on the immersion heater EHE when the DHW cylinder is full and pressurised.

1. Set the required DHW temperature at the temperature controller.

2. Monitor and check for correct function during the first heat-up. At the same time, test the temperature controller's automatic switch-off function.

Note

During the heat-up process water should drip from the safety valve.

Instructing the system user

Instruct the system user on how to operate the immersion heater EHE in conjunction with the heating system as a whole.

The instructions must cover the following points:

- Operating the temperature controller (see page 5)
- What to do in the event of a fault: Disconnect the power supply to the appliance and inform the heating contractor.
- Advise user of the required service intervals in relation to the water hardness (see page 11)
- Advise the user regarding regular operation of the safety valve (see operating instructions for the heating system)
- Further information for the user is available in the operating instructions of the heating system.

Information on users

The immersion heater EHE can also be operated by children 8 years and older, as well as by individuals with reduced physical, sensory or mental faculties or those lacking in experience and knowledge, provided such individuals are being supervised or have been instructed in the safe use of this appliance and any risks arising from it.



Please note

- Supervise children in the proximity of the appliance.
 - Never permit children to play with the appliance.
 - Cleaning and maintenance must never be carried out by unsupervised children.

Ambient conditions



Please note

- Incorrect ambient conditions can lead to heating system damage and can put safe operation at risk.
Ensure ambient temperatures are above 0 °C and below 35 °C.

Auxiliary components, spare and wearing parts



Please note

Components not tested with the heating system may damage the system or affect its function. Have all installation or replacement work carried out exclusively by qualified contractors.

Maintenance and service

Depending on the water hardness and the operating conditions, it may be necessary to descale the heating rods at certain intervals.

The immersion heater EHE will require regular servicing at a water hardness of $> 1.3 \text{ mol/m}^3$ (7 °dH). Alternatively, take suitable measures to lower the lime content in the domestic water supply.

1. Isolate the immersion heater EHE from the power supply and safeguard against reconnection.

2. Drain the DHW cylinder:



DHW cylinder service instructions

3. Remove the immersion heater EHE in reverse order to installation, see page 6.

4. Descale the heating rods.

5. Reinstall the immersion heater EHE, see page 6.

6. Fill the DHW cylinder.



DHW cylinder service instructions

7. Check the function of the safety valve.



DHW cylinder service instructions and safety valve instructions

8. Reconnect the power supply to the immersion heater EHE.

High limit safety cut-out has responded

At a temperature of 98 °C ^{-6K} the high limit safety cut-out switches the immersion heater EHE off.

The contacts open and are locked out.

Immersion heater was not yet operational:

The high limit safety cut-out was triggered due to storage temperatures below -12 °C. Raise the temperature at the sensor to 20 °C, then reset the high limit safety cut-out:

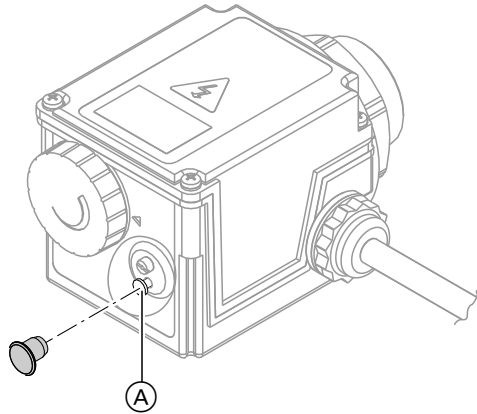

Fig. 4

1. Isolate the power supply and safeguard against unauthorised reconnection.
2. Remove cover with screwdriver.
3. Press reset button (A).
4. Refit the cover.

Immersion heater was operational:

The high limit safety cut-out may have been triggered due to damage on the immersion heater. Therefore do **not** reset the high limit safety cut-out. Replace entire immersion heater.

Declaration of conformity**Immersion heater EHE**

We, Viessmann Werke GmbH & Co. KG, D-35107 Allendorf, declare as sole responsible body that the named product complies with the provisions of the following directives and regulations:

2014/35/EU Low Voltage Directive

2014/30/EU EMC Directive

Applied standards:

EN 60335-1:2012 + A11:2014

EN 61000-3-2:2014

EN 61000-3-3:2013

In accordance with the listed directives, this product is designated with **CE**.

Allendorf, 29 May 2017

Viessmann Werke GmbH & Co. KG



Authorised signatory Manfred Sommer





Applicability

Serial No.:

7571034

7571035

Viessmann Werke GmbH & Co. KG
D-35107 Allendorf
Telephone: +49 6452 70-0
Fax: +49 6452 70-2780
www.viessmann.com

Viessmann Limited
Hortonwood 30, Telford
Shropshire, TF1 7YP, GB
Telephone: +44 1952 675000
Fax: +44 1952 675040
E-mail: info-uk@viessmann.com