

Technical guide

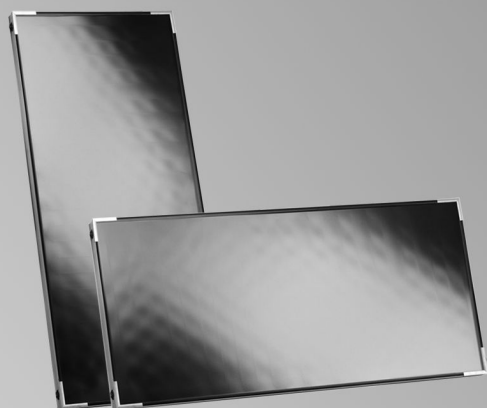

Vitosol 100-FM/100-F

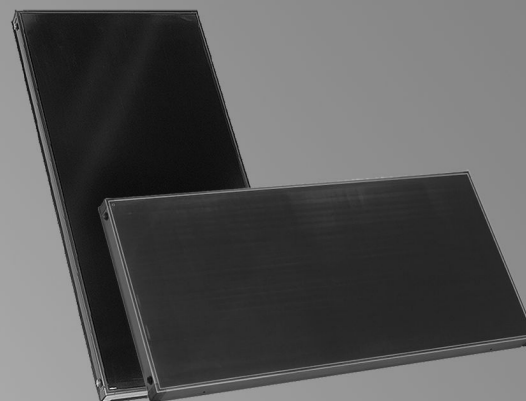

Vitosol 200-FM/200-F

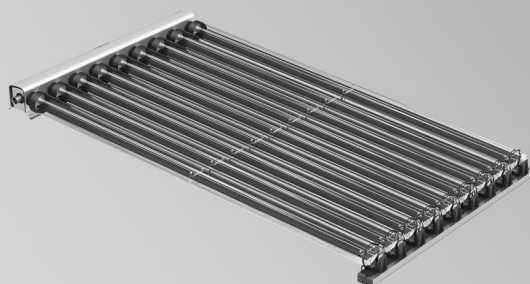

Vitosol 200-TM

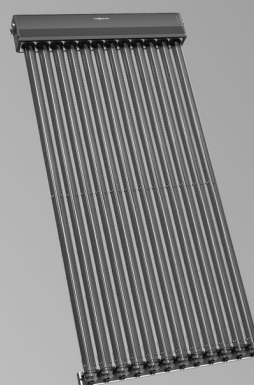

Vitosol 300-TM

VITOSOL 100-FM/-F**Flat-plate collector, type SV and SH**

For installation on flat and pitched roofs and for freestanding installation

Type SH also for installation on walls

VITOSOL 200-FM/-F**Flat-plate collector, type SV2F/SH2F, SV2D**

For installation on flat and pitched roofs and for freestanding installation

Type SH also for installation on walls

VITOSOL 300-TM**Type SP3C**

For installation on flat or pitched roofs, on walls and for freestanding installation

VITOSOL 200-TM**Type SPEA**

For installation on flat and pitched roofs and for freestanding installation

Index

1. Principles	1. 2 Viessmann collector range	6
	■ Vitosol-FM with ThermProtect automatic temperature-dependent shutdown	6
	■ Vitosol 300-TM with automatic temperature-dependent shutdown	6
	■ Vitosol 200-TM with ThermProtect automatic temperature-dependent shutdown	6
	■ Vitosol-F	6
	1. 3 Parameters for collectors	7
	■ Area designations	7
	■ Collector efficiency	7
	■ Thermal capacity	9
	■ Stagnation temperature	9
	■ System filling pressure and steam-producing power	9
	■ Solar coverage	9
	1. 4 Orientation, inclination and shading of the receiver surface	10
	■ Inclination of the receiver surface	10
	■ Orientation of the receiver surface	10
	■ Avoiding shading of the receiver surface	10
2. Vitosol 100-FM, type SV1F/SH1F and Vitosol 100-F, type SV1B/SH1B	2. 1 Product description	11
	■ Benefits	11
	■ Factory setting	11
	2. 2 Specification	12
	2. 3 Tested quality	13
3. Vitosol 200-FM, type SV2F/SH2F and Vitosol 200-F, type SV2D	3. 1 Product description	15
	■ Benefits	15
	■ Factory setting	16
	3. 2 Specification	17
	3. 3 Tested quality	18
4. Vitosol 300-TM, type SP3C	4. 1 Product description	19
	■ Benefits	19
	■ Delivered condition	20
	4. 2 Specification	20
	4. 3 Tested quality	21
5. Vitosol 200-TM, type SPEA	5. 1 Product description	22
	■ Benefits	22
	■ Delivered condition	22
	5. 2 Specification	23
	5. 3 Tested quality	24
6. Solar control units	6. 1 Solar control units in conjunction with Vitotronic control units	25
	■ SDIO/SM1A electronics module	25
	■ Solar control module, type SM1, part no. Z014470	25
	■ Vitosolic 100, type SD1, part no. Z007387	26
	■ Vitosolic 200, type SD4, part no. Z007388	27
	6. 2 Solar control units in conjunction with Vitodens 300-W, type B3HG and Vitodens 200-W, type B2HF	29
	■ SDIO/SM1A electronics module	29
	■ EM-S1 extension (ADIO)	29
	6. 3 Functions	31
	■ Assignment to the solar control units	31
	■ Cylinder temperature limit	31
	■ Collector cooling function	31
	■ Return cooling function	32
	■ Collector emergency stop	32
	■ Minimum collector temperature limit	32
	■ Interval function	32
	■ Cooling function	32
	■ Frost protection	32
	■ Thermostat function	32
	■ Thermostat function, ΔT control and time switches (for Vitosolic 200)	32
	■ Speed control (via PWM signal)	33
	■ Heat statement	33
	■ Reheating suppression	33
	■ Reheating suppression	33
	■ Auxiliary function for DHW heating	33
	■ External heat exchanger	34
	■ Bypass function	34

	■ Parallel relay	34
	■ DHW cylinder 2 (to 4) ON	34
	■ Cylinder heating	34
	■ Cylinder priority control	34
	■ Utilisation of excess heat	34
	■ Cyclical heating	34
	■ Fault notification via relay output	35
	■ Relay kick	35
	■ Saving of operating values to SD card	35
	■ Solar central heating backup	35
	■ Transfer from the solar preheat stage	35
	■ Target temperature control	35
	■ Reduction of stagnation time	35
	■ Night DHW circulation monitoring	35
	■ Operation via boiler control unit	35
	■ dT monitoring	36
	■ Setting for min./max. pump speed	36
6. 4	Accessories	37
	■ Allocation to solar control units	37
	■ Contactor relay	37
	■ Immersion temperature sensor	37
	■ Collector temperature sensor	38
	■ Stainless steel sensor well	38
	■ Heat meter	38
	■ Solar cell	39
	■ Large display	39
	■ High limit safety cut-out	40
	■ Pressure switch	40
	■ Temperature controller as temperature limiter (maximum limit)	40
	■ Temperature controller	41
	■ Temperature controller	41
7.	DHW cylinders	
7. 1	Vitocell 100-U, type CVUB/CVUB-A	42
7. 2	Vitocell 100-B, type CVB/CVBB	46
7. 3	Vitocell 100-V, type CVWA	54
	■ Solar heat exchanger set	59
7. 4	Vitocell 300-B, type EVBA-A	61
7. 5	Vitocell 140-E, type SEIA/SEIC and Vitocell 160-E, type SESB	65
7. 6	Vitocell 340-M, type SVKC and Vitocell 360-M, type SVSB	70
7. 7	Vitocell 100-V, type CVA/CVAA/CVBA-A	76
7. 8	Vitocell 300-V, type EVIA-A, EVIA-A+	83
8.	Installation accessories	
8. 1	Solar-Divicon and solar pump assembly	89
	■ Heat meter	92
	■ Solar safety valve 8 bar	92
8. 2	Hydraulic accessories	93
	■ Connecting tee	93
	■ Connection line	93
	■ Installation kit for connection line	93
	■ Manual air vent valve	94
	■ Air separator	94
	■ Quick-action air vent valve (with tee)	94
	■ Connecting cable	95
	■ Solar flow and return lines	95
	■ Solar line roof outlet	95
	■ Connection accessories for residual lengths of solar flow and return lines	95
	■ Solar expansion vessel	96
	■ Line regulating valve	96
	■ Line regulating valve	96
	■ Automatic thermostatic mixing valve	97
	■ Thermostatic DHW circulation set	97
	■ 3-way diverter valve	97
	■ Threaded DHW circulation fitting	98
8. 3	Heat transfer medium	99
	■ Fill valve	99
	■ Fill station	99
	■ Filling trolley	99
	■ Solar manual fill pump	99
	■ Heat transfer medium "Tyfocor LS"	99
8. 4	Other accessories	100
	■ Transport aid	100

9. Design information regarding installation	<ul style="list-style-type: none"> 9. 1 Snow load and wind load zones 100 9. 2 Distance from the edge of the roof 100 9. 3 Routing pipework 101 9. 4 Equipotential bonding/lightning protection of the solar thermal system 101 9. 5 Thermal insulation 101 9. 6 Solar lines 101 9. 7 Collector fixing 102 <ul style="list-style-type: none"> ■ Above roof installation 103 ■ Flat roof installation 103 ■ Installation on walls 103 	
10. Design information regarding installation on pitched roofs — above roof installation	<ul style="list-style-type: none"> 10. 1 Above roof installation with rafter anchors 104 <ul style="list-style-type: none"> ■ General information 104 ■ Vitosol-FM/-F flat-plate collectors 106 ■ Vitosol 300-TM vacuum tube collectors, type SP3C 107 ■ Vitosol 200-TM vacuum tube collectors, type SPEA 108 ■ Collector supports on pitched roofs 108 10. 2 Above roof installation with rafter hooks 108 <ul style="list-style-type: none"> ■ General information 108 ■ Vitosol-FM/-F flat-plate collectors 109 ■ Vitosol 300-TM vacuum tube collectors, type SP3C 110 ■ Vitosol 200-TM vacuum tube collectors, type SPEA 110 10. 3 Above roof installation with rafter flanges 111 <ul style="list-style-type: none"> ■ General information 111 ■ Vitosol-FM/-F flat-plate collectors 112 ■ Vitosol 300-TM vacuum tube collectors, type SP3C 112 ■ Vitosol 200-TM vacuum tube collectors, type SPEA 113 10. 4 Above roof installation for corrugated sheet roofs 113 10. 5 Above roof installation for sheet metal roofs 114 <ul style="list-style-type: none"> ■ General information 114 	
11. Design information regarding flat roof installation	<ul style="list-style-type: none"> 11. 1 Calculating collector row clearance "z" 114 11. 2 Vitosol-FM/-F flat-plate collectors (on collector supports) 115 <ul style="list-style-type: none"> ■ Collector supports with variable angle of inclination 115 ■ Collector supports with fixed angle of inclination 118 11. 3 Vacuum tube collectors (on collector supports) 119 <ul style="list-style-type: none"> ■ Collector supports with variable angle of inclination 120 ■ Collector supports with fixed angle of inclination 121 11. 4 Vitosol 200-TM vacuum tube collectors, type SPEA and Vitosol 300-TM, type SP3BC (horizontal) 122 <ul style="list-style-type: none"> ■ Type SPEA 123 	
12. Design information for installation on walls	<ul style="list-style-type: none"> 12. 1 Vitosol-FM/-F flat-plate collectors, type SH 123 <ul style="list-style-type: none"> ■ Collector supports – angle γ 10 to 45° 123 12. 2 Vitosol 300-TM vacuum tube collectors, type SP3C 123 	
13. Information regarding design and operation	<ul style="list-style-type: none"> 13. 1 Sizing the solar thermal system 124 <ul style="list-style-type: none"> ■ System for heating DHW 125 ■ System for DHW heating and central heating backup 126 ■ Swimming pool heating system – heat exchanger and collector 127 13. 2 Solar thermal system operating modes 129 <ul style="list-style-type: none"> ■ Flow rate in the collector array 129 ■ Which operating mode is the right one? 129 13. 3 Installation examples Vitosol-FM/-F, types SV and SH 129 <ul style="list-style-type: none"> ■ High flow operation — single sided connection 129 ■ High flow operation — connection on alternate sides 129 ■ Low flow operation — single sided connection 130 ■ Low flow operation — connection on alternate sides 130 13. 4 Installation examples Vitosol 200-TM, type SPEA 130 <ul style="list-style-type: none"> ■ Vertical installation on pitched roofs, installation on collector supports or horizontal installation 130 ■ Horizontal installation on a pitched roof 131 13. 5 Installation examples Vitosol 300-TM, type SP3C 131 <ul style="list-style-type: none"> ■ Vertical installation on pitched roofs, installation on collector supports or horizontal installation 132 ■ Horizontal installation on pitched roofs and on walls 132 13. 6 Pressure drop of the solar thermal system 133 <ul style="list-style-type: none"> ■ Pressure drop of the solar flow and return lines 134 ■ Pressure drop Vitosol-FM/-F, types SV and SH 134 ■ Pressure drop Vitosol 200-TM and Vitosol 300-TM 135 	

13. 7	Flow velocity and pressure drop	136
■	Flow velocity	136
■	Pressure drop of the pipework	137
13. 8	Sizing the circulation pump	138
13. 9	Ventilation	139
13.10	Safety equipment	139
■	Stagnation in solar thermal systems	139
■	Adjust system pressure	142
■	Expansion vessel	142
■	Safety valve	143
■	High limit safety cut-out	143
13.11	Connecting the DHW circulation and automatic thermostatic mixing valve	144
13.12	Intended use	144
14.	Appendix	
14. 1	Subsidy programmes, permits and insurance	145
14. 2	Glossary	145
15.	Keyword index	146

Principles

Together with Viessmann heating systems, solar thermal systems create an optimum system solution for DHW and swimming pool heating, central heating backup and other applications.

This technical guide includes a summary of all technical documents for the required components, as well as design and sizing information especially for systems for detached houses. This technical guide is a product-related addition to Viessmann's "Solar thermal systems" technical guide. The Viessmann "Solar thermal" technical guide is available as a download at <http://www.viessmann.de>. On the website, you will also find electronic aids regarding collector fixing and maintaining the correct pressure in solar thermal systems.

1.2 Viessmann collector range

Vitosol-FM with ThermProtect automatic temperature-dependent shutdown

Vitosol-FM flat-plate collectors feature a unique absorber coating. This coating changes its optical properties subject to temperature. In the standard temperature range of the solar thermal system, the collectors have the same performance values as conventional solar collectors. As soon as the solar cylinder has reached the required heat-up condition, an excess of solar energy causes the collector temperature to rise. If the collector temperature exceeds the switching temperature of the absorber, the output automatically adapts to match the reduced heat draw-off. Stagnation temperatures of max. 145 °C are reached in the collector when the system is at a standstill. When the collector temperature drops, output will increase again. In a solar thermal system with switching flat-plate collectors, the formation of steam can be safely prevented with simultaneous adjustment of the system pressure. This helps to protect the system components (pump, check valves, expansion vessel, etc.) and the heat transfer medium. Reliability and service life are improved.

For economic reasons, the same sizing rules used for conventional flat-plate collectors apply to switching collectors. Due to the low end temperatures, the collector area may be oversized to achieve higher solar coverage.

Vitosol 300-TM with automatic temperature-dependent shutdown

Vacuum tube collector with phase-change temperature-dependent shutdown
The Vitosol 300-TM is a highly efficient vacuum tube collector based on the heat pipe principle, with ThermProtect automatic temperature-dependent shutdown. Solar energy causes the medium sealed inside the heat pipe to evaporate. As it subsequently condenses in the condenser, the heat is transferred to the solar circuit. The medium flows back into the sunlit area of the vacuum tubes. At collector temperatures of 120 °C and above, the medium is no longer able to condense. Thanks to this phase-change temperature shutdown, heat transfer is interrupted and the system is thus protected against excessively high stagnation temperatures. This results in a maximum stagnation temperature of 150 °C.

The collector adjusts itself automatically to the reduced heat consumption. If the collector temperature drops, output will increase again. Simultaneous system pressure adjustment safely prevents steam formation. The system components are protected. For economic reasons, the same sizing rules used for conventional collectors apply to switching collectors. Due to the low end temperatures, the collector area may be oversized to achieve higher solar coverage.

Vitosol 200-TM with ThermProtect automatic temperature-dependent shutdown

The Vitosol 200-TM series solar collector also has ThermProtect phase-change temperature-dependent shutdown. The collector operating principle and shutdown are identical to those of the Vitosol 300-TM. The higher 175 °C stagnation temperature involves controlled evaporation of the heat transfer medium.

Vitosol-F

Solar thermal systems with Vitosol-F supply efficient, reliable renewable heat for DHW heating and central heating backup, or process heat. During summertime, the available solar energy may exceed heat demand. The solar system stagnates, which can have a negative impact on the service life of system components.

It is therefore important that the professional installer ensures sound system sizing. Design the collector area and cylinder size according to the energy requirement. Alternatively, equip collectors with ThermProtect.

1.3 Parameters for collectors

Area designations

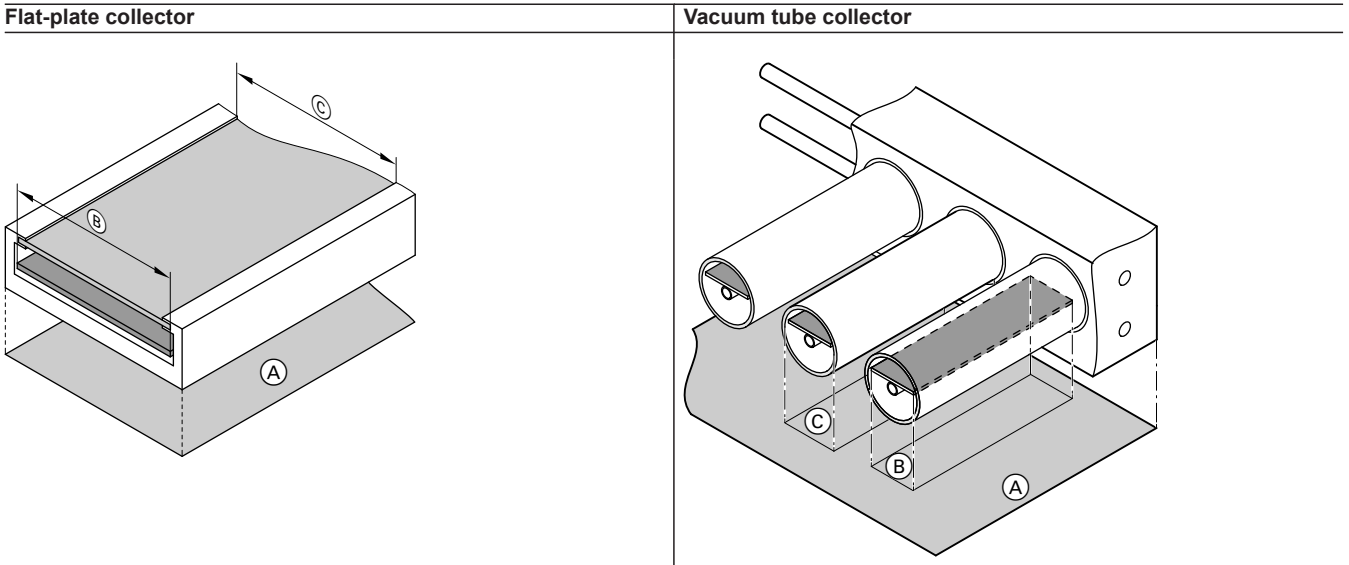

- **Gross area (A)**
Describes the external dimensions (length x width) of a collector. It is decisive when planning the installation and when calculating the roof area required, as well as for most subsidy programs when applying for subsidies.
 - **Absorber area (B)**
Selectively coated metal area, which is set into the collector.
 - **Aperture area (C)**
The aperture area is the technically relevant specification for designing a solar thermal system and for the use of sizing programs.
- Flat-plate collector:**
Area of collector cover through which solar rays can enter.
- Vacuum tube collector:**
Sum of longitudinal sections of the single tubes. Since the tubes are smaller at the top and bottom with no absorber area, the aperture area of these devices is slightly larger than the absorber area.

Collector efficiency

The efficiency of a collector (see chapter "Specification" for the relevant collector) specifies the proportion of insolation hitting the absorber area that can be converted into useable heat. The efficiency depends, among other things, on the operating conditions of the collector. The calculation method is the same for all collector types.

Some of the insolation striking the collectors is "lost" through reflection and absorption at the glass pane and through absorber reflection. The ratio between the insolation striking the collector and the radiation that is converted into heat on the absorber is used to calculate the **optical efficiency η_0** .

When the collector heats up, it transfers some of that heat to the ambience through thermal conduction of the collector material, thermal radiation and convection. These losses are calculated by means of the heat loss factors k_1 and k_2 and the temperature differential ΔT (given in K) between the absorber and the surroundings:

$$\eta = \eta_0 - \frac{k_1 \cdot \Delta T}{E_g} - \frac{k_2 \cdot \Delta T^2}{E_g}$$

Efficiency curves

The optical efficiency η_0 and the heat loss factors k_1 and k_2 , together with temperature differential ΔT and the irradiation intensity E_g are sufficient to determine the efficiency curve. Maximum efficiency is achieved when the differential between the absorber and ambient temperature ΔT is zero, and the thermal losses are also zero. The higher the collector temperature, the higher the heat losses and the lower the efficiency.

The typical operating ranges of the collectors can be read off the efficiency curves. This gives the adjustment options of the collectors.

Typical operating ranges (see following diagram):

- ① Solar thermal system for DHW at low coverage
- ② Solar thermal system for DHW at higher coverage
- ③ Solar thermal systems for DHW and solar central heating backup
- ④ Solar thermal systems for process heat/solar-powered air conditioning

The following diagrams show the efficiency curves relative to the absorber surfaces of the collectors.

Principles (cont.)

Flat-plate collectors

Vitosol 100-FM, type SV1F/SH1F

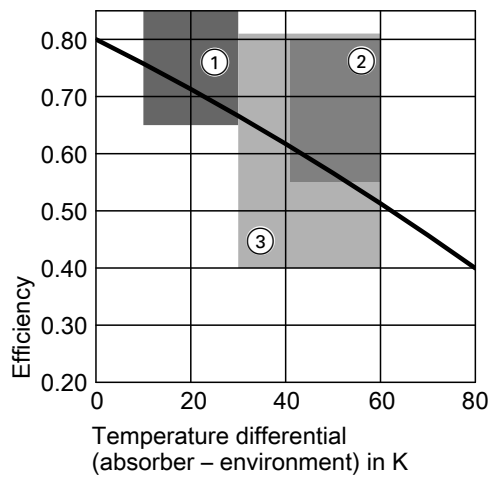

Vitosol 200-FM, type SV2F/SH2F

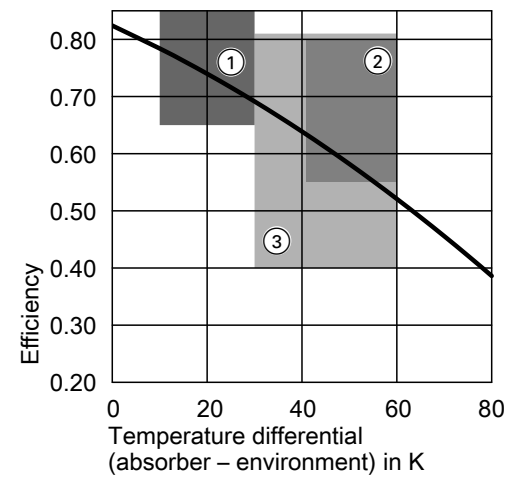

Vitosol 100-F, type SV1B/SH1B

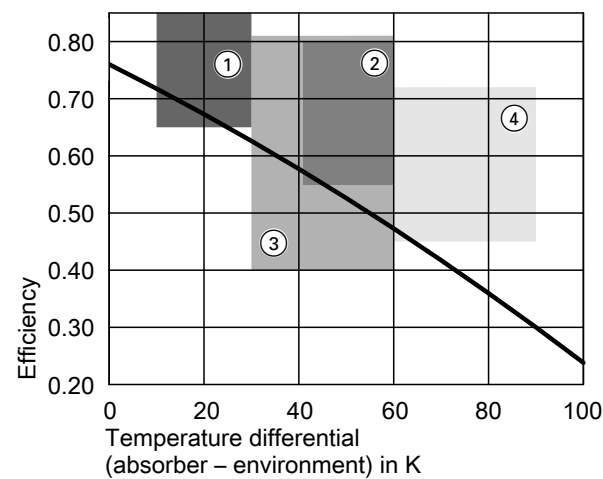

Vitosol 200-F, type SV2D

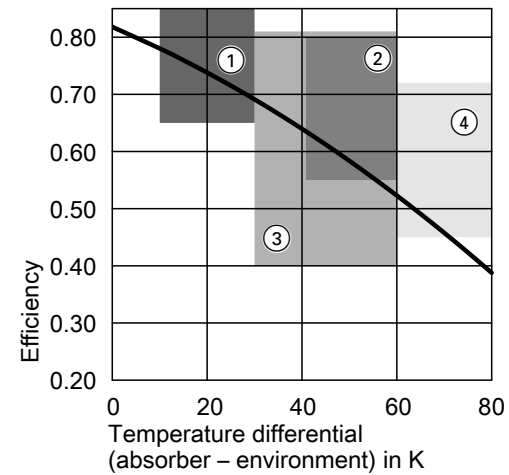

Vacuum tube collectors

Vitosol 300-TM, type SP3C

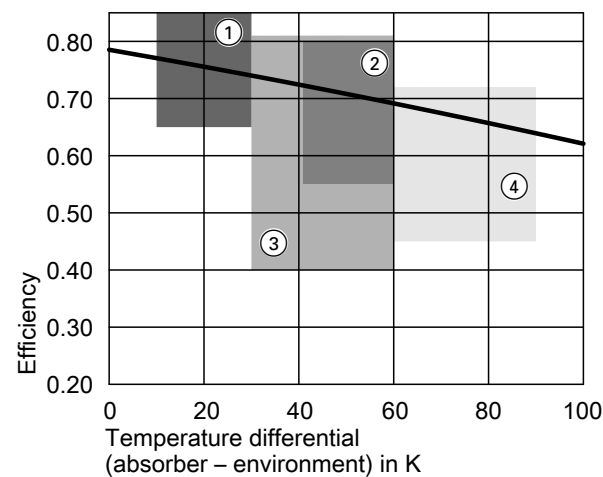

Vitosol 200-TM, type SPEA

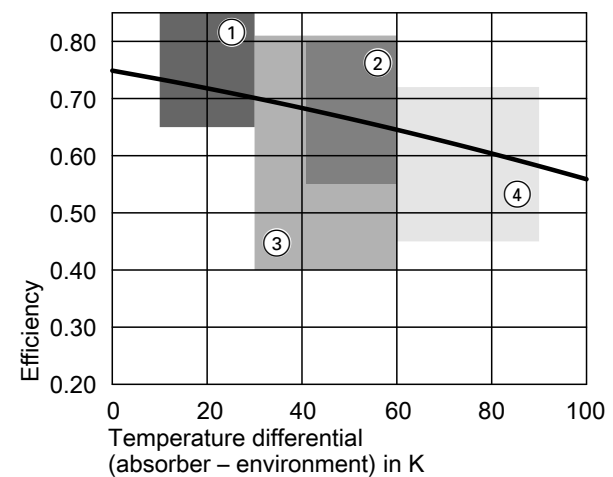

Thermal capacity

The thermal capacity in $\text{kJ}/(\text{m}^2 \cdot \text{K})$ indicates the amount of heat absorbed by the collector per m^2 and K. This heat is only available to the system to a limited extent.

Stagnation temperature

The stagnation temperature is the maximum temperature that the collector can reach during insolation of $1000 \text{ W}/\text{m}^2$.

- Vitosol-FM, with ThermProtect, approx. $145 \text{ }^\circ\text{C}$
- Vitosol 200-TM with temperature-dependent shutdown, approx. $170 \text{ }^\circ\text{C}$
- Vitosol 300-TM with temperature-dependent shutdown, approx. $150 \text{ }^\circ\text{C}$
- Vitosol-F: Approx. $200 \text{ }^\circ\text{C}$

If no heat is drawn from the collector, it will heat up until it reaches the stagnation temperature. In this state, the thermal losses are of the same magnitude as the radiation absorbed.

System filling pressure and steam-producing power

Steam-producing power

The steam-producing power in W/m^2 indicates the maximum power level at which a collector produces steam during stagnation and transfers it to the system, when evaporation occurs.

Switching flat-plate collectors in solar thermal systems with sufficiently high system pressure no longer produce steam. The steam-producing power of such collectors is therefore $0 \text{ W}/\text{m}^2$.

Observe chapter "Safety equipment" on page 139.

Vitosol-F, Vitosol 200-TM

System pressure 1.0 bar . This ensures controlled solar medium evaporation.

Vitosol-FM and Vitosol 300-TM system filling pressure

To prevent evaporation or spread of the solar medium in the solar thermal system, the system filling pressure of the solar thermal system must be increased. At the highest point of the solar thermal system, a pressure of 3.0 bar must be present. See page 142. The static head of the solar thermal system, the pressure reserve for ventilation, and the supplement for the difference in height between the expansion vessel and the safety valve, must also be taken into account when filling the system. Adjust the pre-charge pressure of the expansion vessel to match the relevant system configuration. Always adjust the pre-charge pressure of the expansion vessel before filling the solar thermal system.

Solar coverage

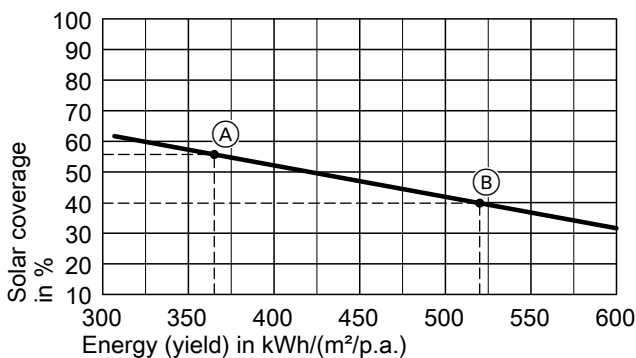

The solar coverage indicates what percentage of the annually required energy for DHW and central heating can be covered by the solar thermal system.

Designing a solar thermal system always entails finding a good compromise between yield and solar coverage. The higher the selected solar coverage, the more conventional energy is saved.

However, high coverage is linked to an excess of heat in summer. This means a lower average collector efficiency and lower yields (energy in kWh) per m^2 absorber area.

- (A) Conventional sizing for DHW systems in detached houses
- (B) Conventional sizing for large solar thermal systems

1.4 Orientation, inclination and shading of the receiver surface

Inclination of the receiver surface

The yield of a solar thermal system varies depending on the inclination and orientation of the collector area. If the receiver surface is angled, the angle of incidence changes, as does the irradiance, and consequently the amount of energy. This is greatest when the radiation hits the receiver surface at right angles. In our latitudes, this case never arises relative to the horizontal. Consequently, the inclination of the receiver surface can optimise the yield. In Germany, a receiver surface angled 35° receives approx. 12 % more energy when oriented towards the south (compared with a horizontal position).

Orientation of the receiver surface

An additional factor for calculating the amount of energy that can be expected is the orientation of the receiver surface. In the northern hemisphere, an orientation towards south is ideal. The following figure shows the interaction of orientation and inclination. Relative to the horizontal, greater or lesser yields result. A range for optimum yield of a solar thermal system can be defined between south-east and south-west and at angles of inclination between 25 and 70°. Greater deviations, for example, for installation on walls, can be compensated for by a correspondingly larger collector area.

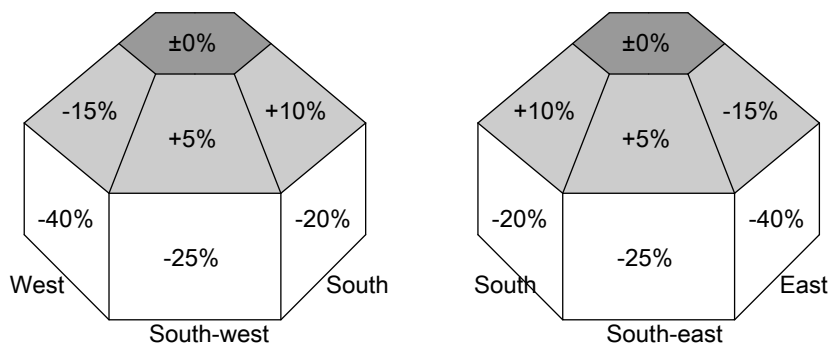

Avoiding shading of the receiver surface

Looking at the installation of a collector facing south, we recommend that the area between south-east and south-west is kept free of shading (at an angle towards the horizon of up to 20°). It should be remembered that the system is to operate for longer than 20 years, and that during this time, for example, trees would grow substantially.

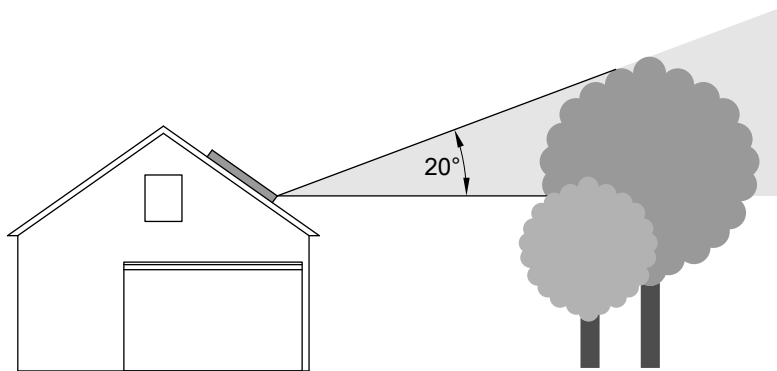

2.1 Product description

The absorbers of the Vitosol 100-F and Vitosol 100-FM collectors, with their selective coating, ensure a high level of absorption of insolation. The copper pipe shaped like a meander ensures an even heat transfer at the absorber.

The collector casing features heat-resistant thermal insulation and a cover made from low ferrous solar glass.

Flexible connection pipes sealed with O-rings provide a secure parallel connection of up to 12 collectors.

A connection set with locking ring fittings enables the collector array to be readily connected to the solar circuit pipework. The collector temperature sensor is mounted in a sensor well set, located in the solar circuit flow.

The collector is available in 2 versions

- Vitosol 100-FM, type SV2F/SH2F with ThermProtect switching absorber coating
- Vitosol 100-F, type SV1B/SH1B with a special absorber coating is designed for coastal regions (see chapter "Specification").

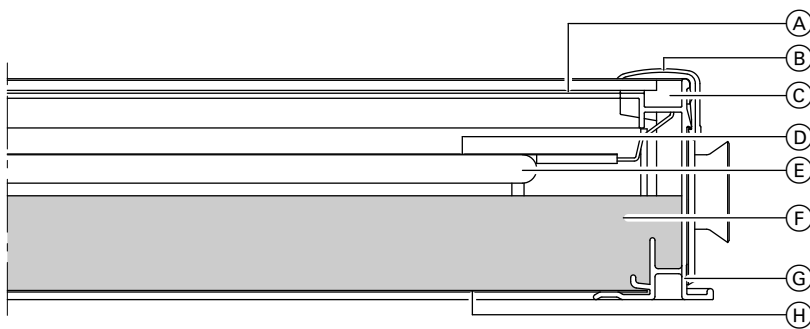

- | | |
|--|--|
| <ul style="list-style-type: none"> (A) Solar glass cover, 3.2 mm (B) Aluminium cover bracket at the collector corners (C) Pane seal (D) Absorber | <ul style="list-style-type: none"> (E) Meander-shaped copper pipe (F) Thermal insulation made from mineral fibre (G) Aluminium frame (H) Steel base plate with an aluminium-zinc coating |
|--|--|

Benefits

- High-performance flat-plate collectors for above roof and flat roof installation. Vitosol-FM version with ThermProtect temperature shutdown for a steam-free and fail-safe solar thermal system
- Absorber designed with meander layout with integral headers. Up to 12 collectors can be linked in parallel.
- Aluminium frame design
- High efficiency due to absorber with selective coating; stable, highly transparent cover made from special glass and highly effective thermal insulation
- Long-lasting impermeability and high stability thanks to all-round folded aluminium frame and seamless pane seal.
- Puncture-proof and corrosion-resistant back panel made from zinc-plated sheet steel
- Easy to assemble Viessmann fixing system with statically tested and corrosion-resistant components made from stainless steel and aluminium – standard for all Viessmann collectors
- Quick and reliable collector connection through flexible corrugated stainless steel pipe push-fit connectors

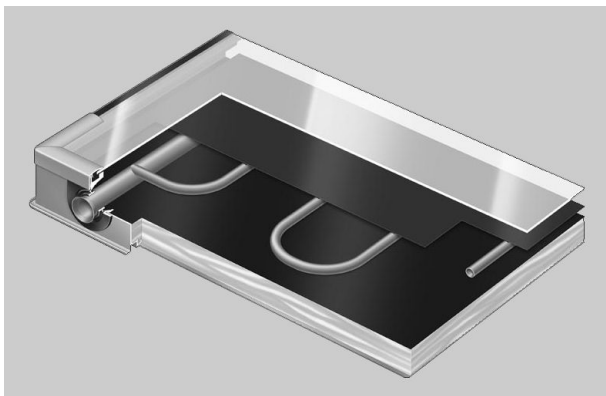

Factory setting

The Vitosol 100-FM/F are delivered fully assembled ready to connect.

2.2 Specification

The collectors are available with 2 different absorber coatings. Type SV1B/SH1B has a special absorber coating that allows these collectors to be used in coastal regions.

Note

Viessmann accepts no liability if the Vitosol 100-FM, type SV1F/SH1F is used in coastal regions.

Distance to the coast:

- Up to 100 m:
Only use type SV1B/SH1B
- 100 to 1000 m:
Type SV1B/SH1B is recommended

Specification

Type		SV1F	SH1F	SV1B	SH1B
Gross area (required when applying for subsidies)	m ²	2.51	2.51	2.51	2.51
Absorber area	m ²	2.31	2.31	2.32	2.32
Aperture area	m ²	2.33	2.33	2.33	2.33
Spacing between collectors	mm	21	21	21	21
Dimensions					
Width	mm	1056	2380	1056	2380
Height	mm	2380	1056	2380	1056
Depth	mm	73	73	72	72
Collector operating range output values					
Optical efficiency					
– Absorber area	%	81.3	81.4		
– Gross area		74.9	74.9		
Heat loss factor k₁					
– Absorber area	W/(m ² · K)	3.849	4.157		
– Gross area		3.542	3.826		
Heat loss factor k₂					
– Absorber area	W/(m ² · K ²)	0.045	0.036		
– Gross area		0.042	0.003		
Theoretical output values across entire temperature range					
Optical efficiency					
– Absorber area	%	82.1	81.7	75.4	75.4
– Gross area		75.5	75.2	69.2	69.2
Heat loss factor k₁					
– Absorber area	W/(m ² · K)	4.854	4.640	4.15	4.15
– Gross area		4.468	4.270	3.81	3.81
Heat loss factor k₂					
– Absorber area	W/(m ² · K ²)	0.023	0.026	0.0114	0.0114
– Gross area		0.021	0.024	0.010	0.010
Thermal capacity	kJ/(m ² · K)	4.7	4.7	4.5	4.5
Weight	kg	39	41	43.9	43.9
Liquid content (heat transfer medium)	Litre	1.83	2.4	1.67	2.33
Permiss. operating pressure					
With installation of an 8 bar safety valve (accessory)	bar/MPa	6/0.6	6/0.6	6/0.6	6/0.6
	bar/MPa	8/0.8	8/0.8	8/0.8	8/0.8
Max. stagnation temperature	°C	145	145	196	196
Steam-producing power					
– Favourable installation position	W/m ²	0 ^{*1}	0 ^{*1}	60	60
– Unfavourable installation position	W/m ²	0 ^{*1}	0 ^{*1}	100	100
Connection	Ø mm	22	22	22	22

Specification for determining the energy efficiency class (ErP label)

Type		SV1F	SH1F	SV1B	SH1B
Aperture area	m ²	2.33	2.33	2.33	2.33
The following values apply to the aperture area:					
– Collector efficiency η_{col} , at a temperature differential of 40 K		59	59	57.0	57.0
– Optical efficiency in the collector	%	81	81	75.4	75.4
– Heat loss factor k₁	W/(m ² · K)	4.81	4.6	4.14	4.14
– Heat loss factor k₂	W/(m ² · K ²)	0.022	0.025	0.0114	0.0114
Incidence angle modifier IAM		0.89	0.89	0.89	0.89

*1 Provided manufacturer's specifications for the filling pressure of the solar thermal system are adhered to.

Vitosol 100-FM, type SV1F/SH1F and Vitosol 100-F, type SV1B/SH1B (cont.)

Type	SV1F	SH1F	SV1B	SH1B
Installation position (see following diagram)	(A), (C), (D)	(B), (C), (D), (E)	(A), (C), (D)	(B), (C), (D), (E)

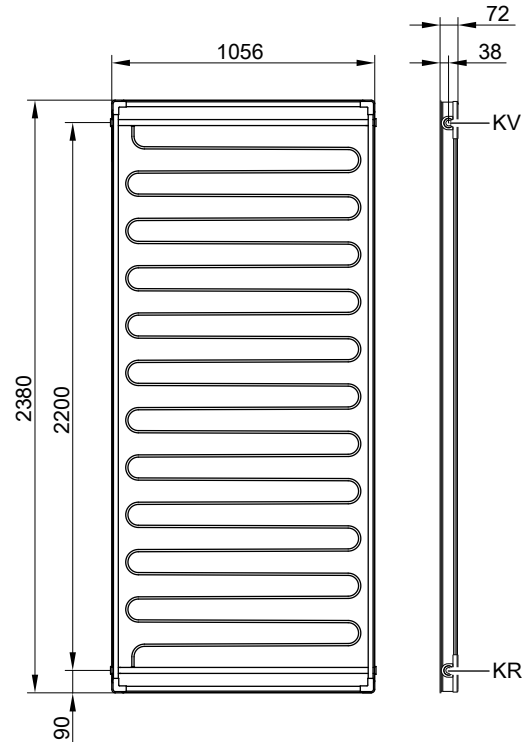
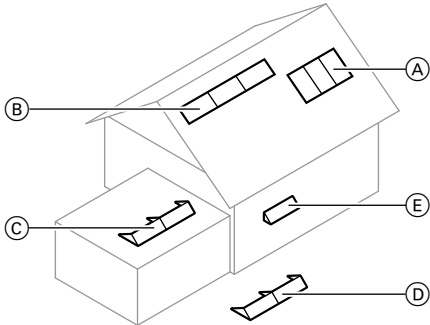

Type SV1F/SV1B

KR Collector return (inlet)
KV Collector flow (outlet)

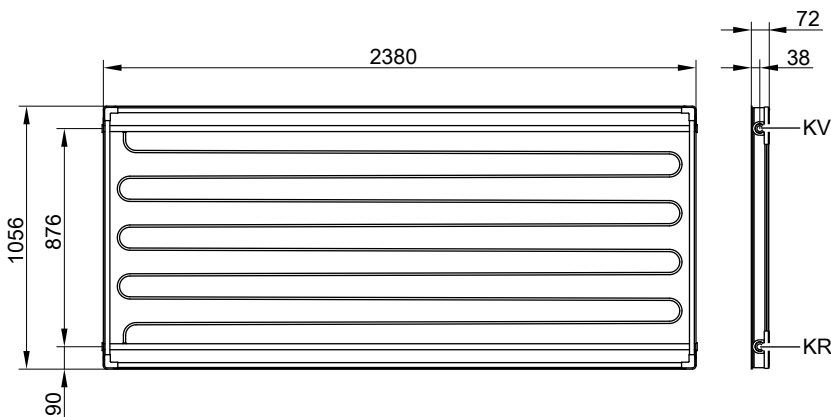

Type SH1F/SH1B

KR Collector return (inlet)
KV Collector flow (outlet)

2.3 Tested quality

5822440 These collectors meet the requirements of the "Blue Angel" eco-label to RAL UZ 73.

Tested in accordance with Solar KEYMARK to EN 12975 or ISO 9806.

 CE designation according to current EC Directives

3.1 Product description

The main component of the Vitosol 200-FM and Vitosol 200-F collectors is the absorber with its highly selective coating. It ensures high absorption of insolation. A meander-shaped copper pipe through which the heat transfer medium flows is fitted to the absorber.

The heat transfer medium absorbs the absorber heat through the copper pipe. The absorber is encased in a highly insulated collector housing that minimises the heat losses of the collector.

The high grade thermal insulation provides temperature stability and is non-outgassing. The collector is covered with a solar glass panel. The glass has a very low iron content which reduces reflection losses.

Up to 12 collectors can be combined to create a single collector array. For this purpose, the standard delivery includes flexible connection pipes with O-rings.

A connection set with locking ring fittings enables the collector array to be readily connected to the solar circuit pipework. The collector temperature sensor is mounted in a sensor well set, located in the solar circuit flow.

The collector is available in 2 versions

- Vitosol 200-FM, type SV2F/SH2F with ThermProtect switching absorber coating
- The Vitosol 200-F, type SV2D with a special absorber coating is designed for coastal regions (see chapter "Specification").

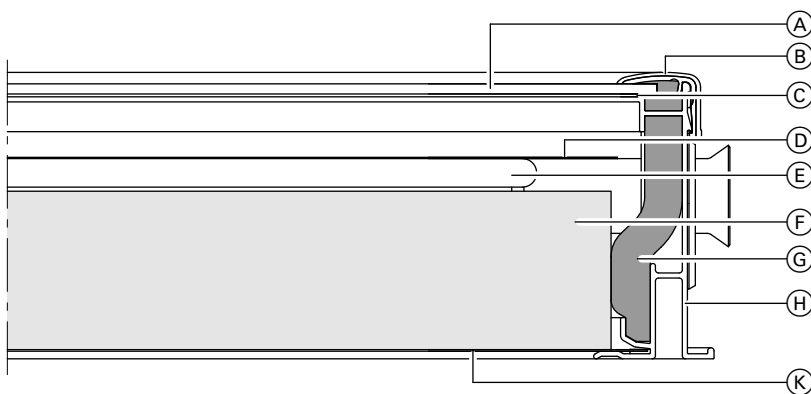

- | | |
|--|---|
| <ul style="list-style-type: none"> Ⓐ Solar glass cover, 3.2 mm Ⓑ Aluminium cover strip in dark blue Ⓒ Pane seal Ⓓ Absorber | <ul style="list-style-type: none"> Ⓔ Meander-shaped copper pipe Ⓕ Melamine resin foam insulation Ⓖ Melamine resin foam insulation Ⓗ Aluminium frame in dark blue Ⓚ Steel base plate with an aluminium-zinc coating |
|--|---|

Benefits

- High-performance flat-plate collectors for above roof and flat roof installation. Vitosol-FM version with ThermProtect temperature shutdown for a steam-free and fail-safe solar thermal system
- Absorber designed with meander layout with integral headers. Up to 12 collectors can be linked in parallel.
- Attractive collector design; frame in dark blue. Upon request, the frame is also available in all other RAL colours.
- High efficiency due to absorber with selective coating; stable, highly transparent cover made from special glass and highly effective thermal insulation
- Long-lasting impermeability and high stability thanks to all-round folded aluminium frame and seamless pane seal.
- Puncture-proof and corrosion-resistant back panel made from zinc-plated sheet steel
- Easy to assemble Viessmann fixing system with statically tested and corrosion-resistant components made from stainless steel and aluminium – standard for all Viessmann collectors
- Quick and reliable collector connection through flexible corrugated stainless steel pipe push-fit connectors

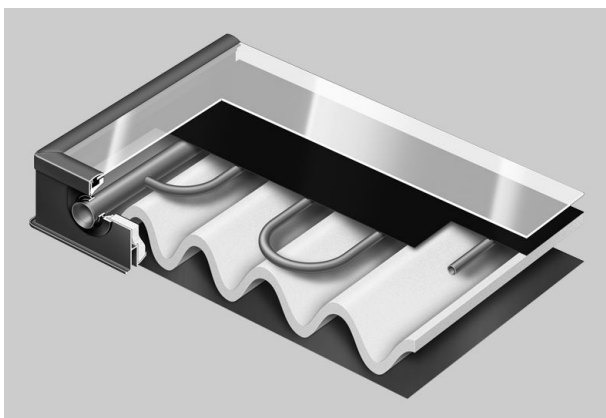

5822440

Vitosol 200-FM, type SV2F/SH2F and Vitosol 200-F, type SV2D (cont.)

Factory setting

The Vitosol 200-FM/-F is delivered fully assembled ready to connect.

Viessmann offers complete solar thermal systems with Vitosol 200-FM/-F (packs) for DHW heating and/or central heating backup (see pack pricelist).

3.2 Specification

The collectors are available with 2 different absorber coatings. Type SV2D has a special absorber coating that allows these collectors to be used in coastal regions.

Note

Viessmann accepts no liability if Vitosol 200-FM, type SV2F/SH2F are used in these regions.

Distance to the coast:

- Up to 100 m:
Only use type SV2D
- 100 to 1000 m:
Type SV2D is recommended

Specification

Type		SV2F	SH2F	SV2D
Gross area (required when applying for subsidies)	m ²	2.51	2.51	2.51
Absorber area	m ²	2.31	2.31	2.32
Aperture area	m ²	2.33	2.33	2.33
Spacing between collectors	mm	21	21	21
Dimensions				
Width	mm	1056	2380	1056
Height	mm	2380	1056	2380
Depth	mm	90	90	90
Collector operating range output values				
Optical efficiency				
– Absorber area	%	82.3	82.6	
– Gross area		75.7	76.0	
Heat loss factor k₁				
– Absorber area	W/(m ² · K)	4.421	4.380	
– Gross area		4.069	4.031	
Heat loss factor k₂				
– Absorber area	W/(m ² · K ²)	0.022	0.037	
– Gross area		0.020	0.034	
Theoretical output values across entire temperature range				
Optical efficiency				
– Absorber area	%	82.7	82.9	82.0
– Gross area		76.1	76.3	75.7
Heat loss factor k₁				
– Absorber area	W/(m ² · K)	4.791	4.907	3.553
– Gross area		4.410	4.516	3.280
Heat loss factor k₂				
– Absorber area	W/(m ² · K ²)	0.025	0.029	0.023
– Gross area		0.023	0.026	0.021
Thermal capacity	kJ/(m ² · K)	4.89	5.96	5.47
Weight	kg	39	40	41
Liquid content (heat transfer medium)	Litre	1.83	2.4	1.83
Permiss. operating pressure				
With installation of an 8 bar safety valve (accessory)	bar/MPa	6/0.6	6/0.6	6/0.6
	bar/MPa	8/0.8	8/0.8	8/0.8
Max. stagnation temperature in the collector	°C	145	145	205
Steam-producing power				
– Favourable installation position	W/m ²	0 ^{*1}	0 ^{*1}	60
– Unfavourable installation position	W/m ²	0 ^{*1}	0 ^{*1}	100
Connection	Ø mm	22	22	22

Specification for determining the energy efficiency class (ErP label)

Type		SV2F	SH2F	SV2D
Aperture area	m ²	2.33	2.33	2.33
The following values apply to the aperture area:				
– Collector efficiency η_{col} , at a temperature differential of 40 K	%	59	58	63.9
– Optical efficiency	%	82	82	81.7
– Heat loss factor k₁	W/(m ² · K)	4.75	4.86	3.538
– Heat loss factor k₂	W/(m ² · K ²)	0.024	0.028	0.023
Incidence angle modifier IAM		0.89	0.89	0.91

*1 Provided manufacturer's specifications for the filling pressure of the solar thermal system are adhered to.

Vitosol 200-FM, type SV2F/SH2F and Vitosol 200-F, type SV2D (cont.)

Type	SV2F	SH2F	SV2D
Installation position (see following diagram)	(A, C, D)	(B, C, D, E)	(A, C, D)

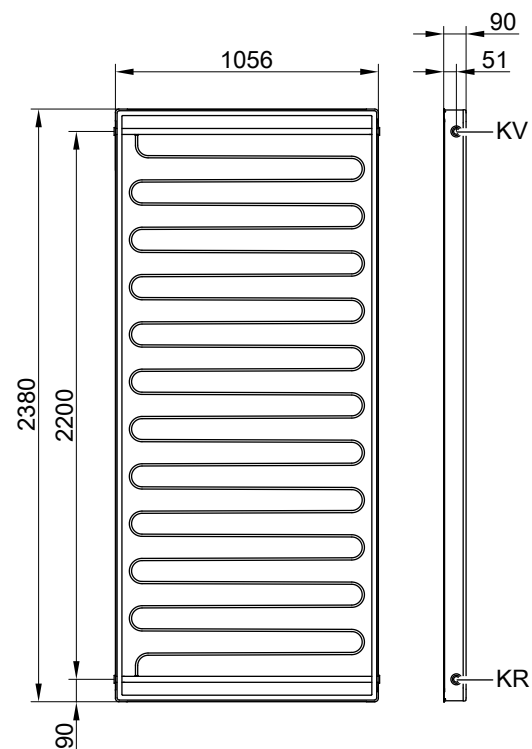
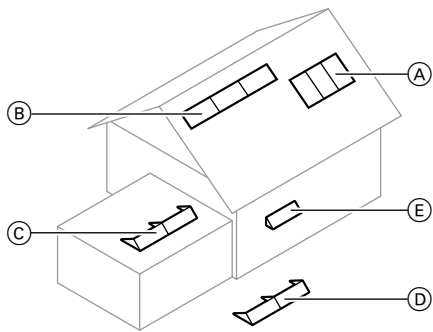

Type SV2F/SV2D

KR Collector return (inlet)
KV Collector flow (outlet)

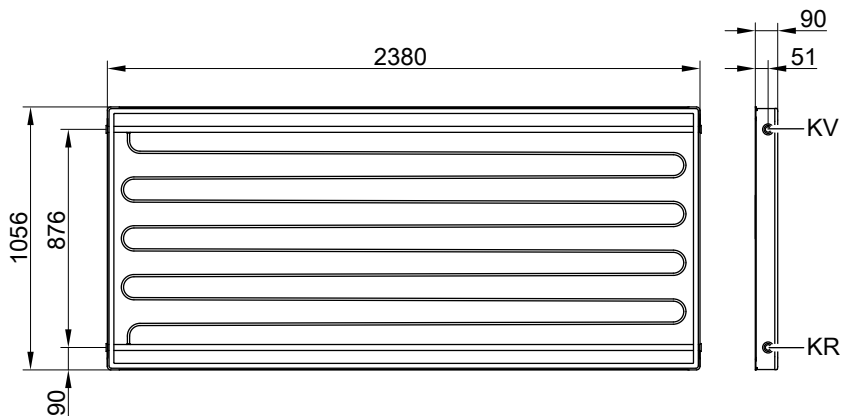

Type SH2F

KR Collector return (inlet)
KV Collector flow (outlet)

3.3 Tested quality

These collectors meet the requirements of the "Blue Angel" eco-label to RAL UZ 73.
Tested in accordance with Solar KEYMARK to EN 12975 or ISO 9806.

 CE designation according to current EC Directives

4.1 Product description

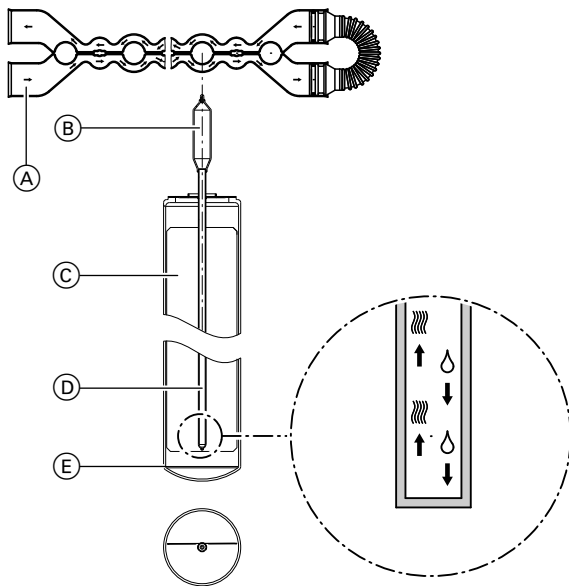

- (A) Copper double pipe heat exchanger
- (B) Condenser
- (C) Absorber
- (D) Heat pipe
- (E) Evacuated glass tube

The Vitosol 300-TM vacuum tube collector, type SP3C, is available in the following versions:

- 1.26 m² with 10 vacuum tubes
- 1.51 m² with 12 vacuum tubes
- 3.03 m² with 24 vacuum tubes

Benefits

- Highly efficient vacuum tube collector based on the heat pipe principle, with ThermProtect automatic temperature-dependent shut-down for high operational reliability
- Universal application through vertical or horizontal installation in any location, either on rooftops or walls, or for freestanding installation
- Narrow balcony module (1.26 m² absorber area) for installation on balcony railings or walls
- The absorber surface with highly selective coating integrated into the vacuum tubes is not susceptible to contamination
- Efficient heat transfer through fully encapsulated condensers and Duotec copper double pipe heat exchanger
- Vacuum tubes can be rotated for optimum alignment with the sun, thereby maximising the energy utilisation
- Dry connection, meaning vacuum tubes can be inserted or changed while the system is full
- Highly effective thermal insulation for minimised heat losses from the header casing
- Easy installation through the Viessmann assembly and connection systems



The Vitosol 300-TM, type SP3C, can be installed on pitched roofs, flat roofs, on walls, or as a freestanding collector.

On pitched roofs the collectors may be positioned in line (vacuum tubes at right angles to the roof ridge) or across (vacuum tubes parallel to the roof ridge).

An absorber with highly selective coating is incorporated inside each vacuum tube. The absorber ensures high absorption of insolation and low emissions of thermal radiation.

A heat pipe filled with an evaporation liquid is fitted to the absorber. The heat pipe is connected to the condenser. The condenser is fitted inside a Duotec copper double pipe heat exchanger.

This involves a so-called "dry connection", i.e. the vacuum tubes can be rotated or replaced even when the installation is filled and under pressure.

The heat is transferred from the absorber to the heat pipe. This causes the liquid to evaporate. The steam rises into the condenser. The heat is transferred to the passing heat transfer medium by the double pipe heat exchanger containing the condenser. This causes the steam to condense. The condensate returns back down into the heat pipe and the process repeats.

The inclination angle to horizontal must be greater than zero to guarantee circulation of the evaporator liquid in the heat exchanger.

The vacuum tubes can be rotated to precisely align the absorber with the sun. The vacuum tubes can be rotated through 25° without casting shade on the absorber surface.

Up to 15 m² absorber area can be connected to form one collector array. For this purpose, the standard delivery includes flexible connection pipes with O-rings. The connection pipes are clad with a thermally insulated covering.

A connection set with locking ring fittings enables the collector array to be readily connected to the solar circuit pipework. The collector temperature sensor is installed in a sensor retainer on the flow pipe in the header casing of the collector.

The collectors can also be used in coastal regions.

Vitosol 300-TM, type SP3C (cont.)

Delivered condition

Packed in separate boxes:

1.26 m ²	10 vacuum tubes per packing unit Header casing with mounting rails
1.51 m ² /3.03 m ²	12 vacuum tubes per packing unit Header casing with mounting rails

Viessmann offers complete solar thermal systems with Vitosol 300-TM (packs) for DHW heating and/or central heating backup (see pack pricelist).

4.2 Specification

Specification

Type SP3C		1.25 m ²	1.51 m ²	3.03 m ²
Number of tubes		10	12	24
Gross area	m ²	1.98	2.36	4.62
(required when applying for subsidies)				
Absorber area	m ²	1.26	1.51	3.03
Aperture area	m ²	1.33	1.60	3.19
Clearance between collectors	mm	—	88.5	88.5
Dimensions				
Width a	mm	885	1053	2061
Height b	mm	2241	2241	2241
Depth c	mm	150	150	150
The following values apply to the absorber area:				
– Optical efficiency	%	79.2	79.7	78.2
– Heat loss factor k₁	W/(m ² · K)	1.512	2.02	1.761
– Heat loss factor k₂	W/(m ² · K ²)	0.027	0.006	0.008
The following values apply to the aperture area:				
– Optical efficiency	%	75	75.2	74
– Heat loss factor k₁	W/(m ² · K)	1.432	1.906	1.668
– Heat loss factor k₂	W/(m ² · K ²)	0.025	0.006	0.007
The following values apply to the gross area:				
– Optical efficiency	%	50.4	51	51.4
– Heat loss factor k₁	W/(m ² · K)	0.932	1.292	1.158
– Heat loss factor k₂	W/(m ² · K ²)	0.017	0.004	0.005
Thermal capacity	kJ/(m ² · K)	6.08	5.97	5.73
Weight	kg	33	39	79
Liquid content (heat transfer medium)	litres	0.75	0.87	1.55
Permiss. operating pressure	bar/MPa	6/0.6	6/0.6	6/0.6
With installation of an 8 bar safety valve (accessories)	bar/MPa	8/0.8	8/0.8	8/0.8
Max. stagnation temperature	°C	150	150	150
Steam-producing power	W/m ²	0	0	0
Connection	Ø mm	22	22	22

Specification for determining the energy efficiency class (ErP label)

Type SP3C		1.26 m ²	1.51 m ²	3.03 m ²
Aperture area	m ²	1.33	1.6	3.19
The following values apply to the aperture area:				
– Collector efficiency $\eta_{col.}$ at a temperature differential of 40 K	%	68	69	69
Optical efficiency	%	74	76	76
– Heat loss factor k₁	W/(m ² · K)	1.3	1.3	1.3
– Heat loss factor k₂	W/(m ² · K ²)	0.007	0.007	0.007
Incidence angle modifier IAM		0.98	0.98	0.98

Vitosol 300-TM, type SP3C (cont.)

Installation position (see following diagram)

Ⓐ, Ⓑ, Ⓒ, Ⓓ, Ⓔ, Ⓕ

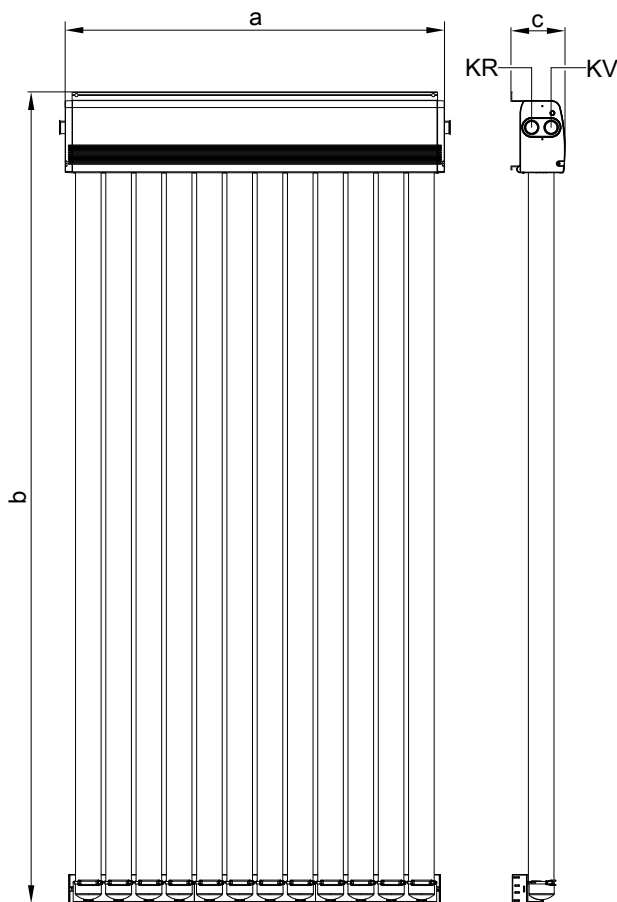
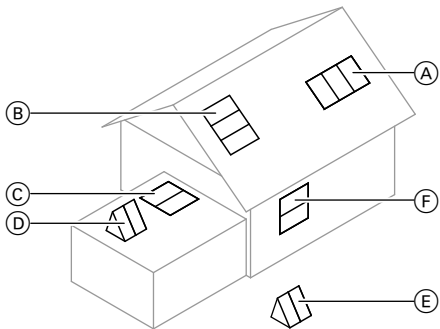

KR Collector return (inlet)
KV Collector flow (outlet)

4.3 Tested quality

These collectors meet the requirements of the "Blue Angel" eco-label to RAL UZ 73.
Tested in accordance with Solar KEYMARK to EN 12975 or ISO 9806.

CE CE designation according to current EC Directives

5.1 Product description

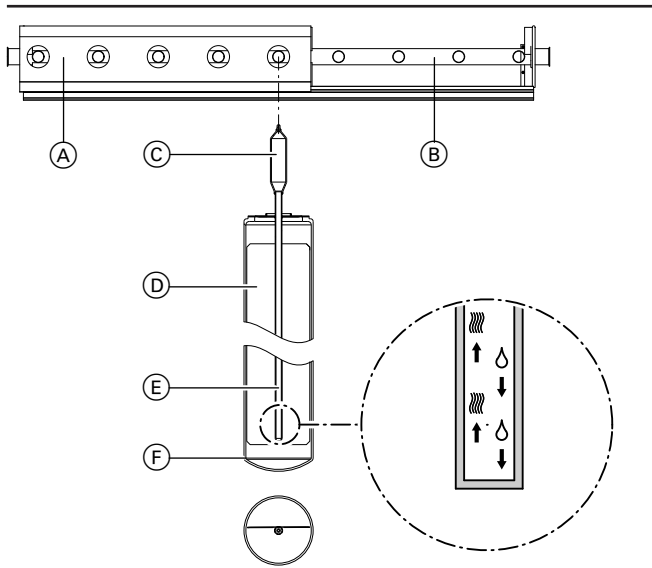

- (A) Aluminium casing
- (B) Heat exchanger
- (C) Condenser
- (D) Absorber
- (E) Heat pipe
- (F) Evacuated glass tube

The Vitosol 200-TM vacuum tube collector, type SPEA, is available in the following versions:

- 1.63 m² with 9 vacuum tubes
- 3.26 m² with 18 vacuum tubes

The Vitosol 200-TM, type SPEA, can be installed on pitched roofs, flat roofs, or as a freestanding collector.

Benefits

- Highly efficient vacuum tube collector based on the heat pipe principle, with ThermProtect automatic temperature-dependent shut-down for high operational reliability
- The absorber surface with highly selective coating integrated into the vacuum tubes is not susceptible to contamination
- Efficient heat transfer through a condenser fully surrounded by the heat exchanger
- Vacuum tubes can be rotated for optimum alignment with the sun, thereby maximising the energy utilisation.
- Dry connection, meaning tubes can be inserted or changed while the system is full
- Highly effective thermal insulation for minimised heat losses from the header casing
- Easy installation through the Viessmann assembly and connection systems

On pitched roofs the collectors may be positioned in line (vacuum tubes at right angles to the roof ridge) or across (vacuum tubes parallel to the roof ridge).

A metal absorber with highly selective coating is incorporated inside each vacuum tube. The metal absorber ensures high absorption of insolation and low emissions of thermal radiation.

A heat pipe filled with an evaporation liquid is fitted to the absorber. The heat pipe is connected to the condenser. The condenser is fitted inside a copper sensor well heat exchanger.

This involves a so-called "dry connection", i.e. the vacuum tubes can be replaced even when the system is filled and under pressure.

The heat is transferred from the absorber to the heat pipe. This causes the liquid to evaporate. The steam rises into the condenser. Heat is transferred by the heat exchanger with its copper manifold, which contains the condenser, to the heat transfer medium as it flows past. This causes the steam to condense. The condensate returns back down into the heat pipe and the process repeats.

The angle of inclination must be greater than zero to guarantee circulation of the evaporator liquid in the heat exchanger.

The vacuum tubes can be rotated to precisely align the absorber with the sun. The vacuum tubes can be rotated through 45° with reduced shade on the absorber surface.

Up to 16.3 m² (or 5 collector modules) absorber area can be connected to form one collector array. For this purpose, the standard delivery includes flexible connection pipes with O-rings.

A calculation of the pressure drops in dependence of the required system flow rate (collectors, pipework, heat exchangers, etc.) is required. The correct pump size for higher pump rates (> 4 collectors) also has to be determined.

A connection set with locking ring fittings enables the collector array to be readily connected to the solar circuit pipework. The connection set is available with or without sensor well. The collector temperature sensor is fitted in the connection set sensor well.

The collectors can also be used in coastal regions.

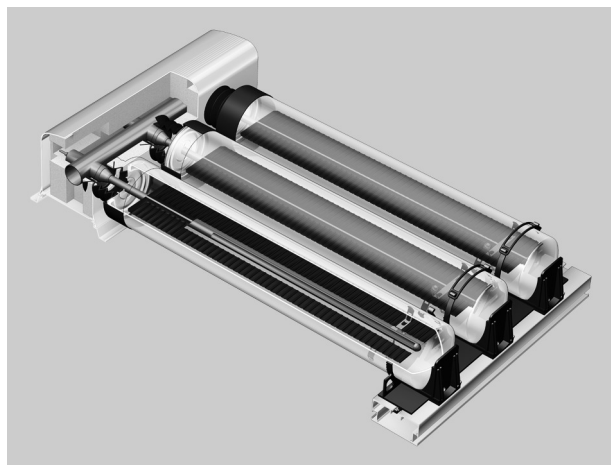

Delivered condition

Packed in separate boxes:

- 9 vacuum tubes per packing unit
- Header casing with mounting rails

5.2 Specification

Specification

Type SPEA		1.63 m ²	3.26 m ²
Number of tubes		9	18
Gross area (required when applying for subsidies)	m ²	2.67	5.3
Absorber area	m ²	1.63	3.26
Aperture area	m ²	1.73	3.46
Clearance between collectors	mm	44	44
Dimensions			
Width	mm	1194	2364
Height	mm	2244	2244
Depth	mm	160	160
The following values apply to the absorber area:			
– Optical efficiency	%	78.5	76.7
– Heat loss factor k₁	W/(m ² · K)	1.847	1.649
– Heat loss factor k₂	W/(m ² · K ²)	0.005	0.006
The following values apply to the aperture area:			
– Optical efficiency	%	73.9	72.3
– Heat loss factor k₁	W/(m ² · K)	1.74	1.554
– Heat loss factor k₂	W/(m ² · K ²)	0.004	0.006
The following values apply to the gross area:			
– Optical efficiency	%	47.9	47.2
– Heat loss factor k₁	W/(m ² · K)	1.127	1.014
– Heat loss factor k₂	W/(m ² · K ²)	0.003	0.004
Thermal capacity	kJ/(m ² · K)	3.23	3.28
Weight	kg	64	129
Liquid content (heat transfer medium)	litres	0.86	1.72
Permiss. operating pressure	bar/MPa	6/0.6	6/0.6
With installation of an 8 bar safety valve (accessories)	bar/MPa	8/0.8	8/0.8
Max. stagnation temperature	°C	175	175
Steam-producing power	W/m ²	60	60
Connection	Ø mm	22	22

Specification for determining the energy efficiency class (ErP label)

Type SPEA		1.63 m ²	3.26 m ²
Aperture area	m ²	1.73	3.46
The following values apply to the aperture area:			
– Collector efficiency η_{col} , at a temperature differential of 40 K	%	65	65
– Optical efficiency	%	71	71
– Heat loss factor k₁	W/(m ² · K)	1.2	1.2
– Heat loss factor k₂	W/(m ² · K ²)	0.006	0.006
Incidence angle modifier IAM		0.88	0.88

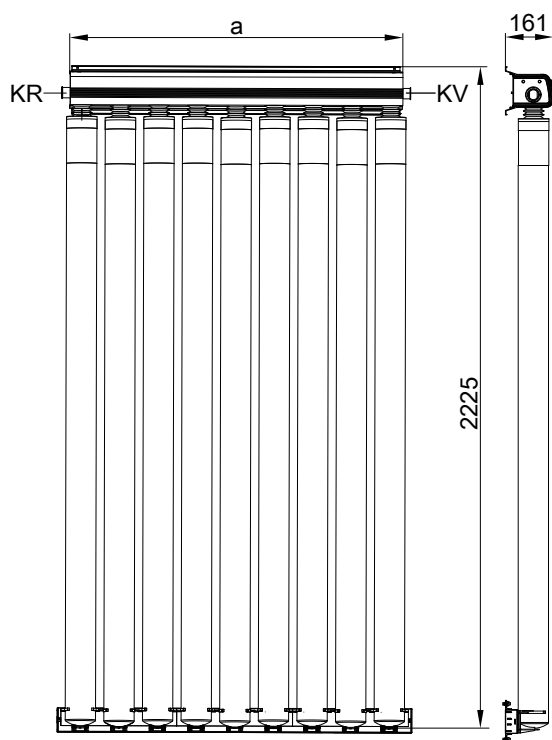

KR Collector return (inlet)
KV Collector flow (outlet)

Note

Use different fixing kits according to snow load. See pricelist.

5

5.3 Tested quality

These collectors meet the requirements of the "Blue Angel" eco-label to RAL UZ 73.
Tested in accordance with Solar KEYMARK to EN 12975 or ISO 9806.

 CE designation according to current EC Directives

Solar control units

6.1 Solar control units in conjunction with Vitotronic control units

SDIO/SM1A electronics module

- Integrated in the DHW cylinder and Solar-Divicon
- Compatible with Viessmann control units with PlusBus or KM-BUS communication
- Automatic differentiation between PlusBus and KM-BUS subscribers

Functions with Vitotronic control units via KM-BUS

- Output statement and diagnostic system
- Operation and display via the Vitotronic control unit.
- Switching the solar circuit pump
- Heating of 2 consumers via a collector array
- 2nd temperature differential control
- Thermostat function for reheating or utilising excess heat
- Speed control for solar circuit pump via PWM input (make: Grundfos and Wilo)
- Suppression of DHW cylinder reheating by the heat generator subject to solar yield
- Heat-up of the solar preheating stage (with DHW cylinder from 400 l capacity)
- Collector safety shutdown
- Electronic temperature limitation in the DHW cylinder
- Switching of an additional pump or valve via relay
- Frost protection function
- General function overview: See chapter "Functions".

To implement the following functions, also order immersion temperature sensor, part no. 7438702:

- Return changeover between heat generator and heating water buffer cylinder
- Heating of 2 consumers via a collector array

Design

- PCB
- Terminals:
 - 4 sensors
 - Solar circuit pump
 - KM-BUS/PlusBus
 - Power supply (on-site ON/OFF switch)
- PWM output for switching the solar circuit pump
- 1 relay for switching one pump or one valve

Collector temperature sensor

For connection inside the device.

On-site extension of the connecting lead:

- 2-core lead, length up to 60 m with a cross-section of 1.5 mm² (copper)
- Never route this lead immediately next to 230/400 V cables

Specification, collector temperature sensor

Lead length	2.5 m
IP rating	IP 32 to EN 60529; ensure through design/installation.
Sensor type	Viessmann NTC 20 kΩ at 25 °C
Permissible ambient temperature	
– Operation	–20 to +200 °C
– Storage and transport	–20 to +70 °C

Cylinder temperature sensor

The sensor is connected inside the control unit.

Specification, cylinder temperature sensor

IP rating	IP 32 to EN 60529; ensure through design/installation.
Sensor type	Viessmann NTC 10 kΩ at 25 °C
Permissible ambient temperature	
– Operation	0 to +90 °C
– Storage and transport	–20 to +70 °C

Specification, SDIO/SM1A electronics module

Rated voltage	230 V ~
Rated frequency	50 Hz
Rated current	2 A
Power consumption	1.5 W
Protection class	I
IP rating	IP 20D to EN 60529; ensure through design/installation.
Permissible ambient temperature	
– Operation	0 to +40 °C, for use in the living space or boiler room (standard ambient conditions)
– Storage and transport	–20 to +65 °C
Rated relay output breaking capacity	
– Semi-conductor relay 1	1 (1) A, 230 V~
– Relay 2	1 (1) A, 230 V~
– Total	Max. 2 A

Solar control module, type SM1, part no. Z014470

- Function extension inside enclosure for wall mounting
- KM-BUS subscribers

Functions

- Output statement and diagnostic system
- Operation and display via the Vitotronic control unit.

- Switching the solar circuit pump
- Heating of 2 consumers via a collector array
- 2nd temperature differential control
- Thermostat function for reheating or utilising excess heat
- Speed control for solar circuit pump via PWM input (make: Grundfos and Wilo)

Solar control units (cont.)

- Suppression of DHW cylinder reheating by the heat generator subject to solar yield
- Heat-up of the solar preheating stage (with DHW cylinders from 400 l capacity)
- Collector safety shutdown
- Electronic temperature limitation in the DHW cylinder
- Switching of an additional pump or valve via relay
- Frost protection function
- General function overview: See chapter "Functions".

To implement the following functions, also order immersion temperature sensor, part no. 7438702:

- Return changeover between heat generator and heating water buffer cylinder
- Heating of 2 consumers via a collector array

Design

- PCB
- Terminals:
 - 4 sensors
 - Solar circuit pump
 - KM-BUS
 - Power supply (on-site ON/OFF switch)
- PWM output for switching the solar circuit pump
- 1 relay for switching one pump or one valve

Collector temperature sensor

For connection inside the appliance
On-site extension of the connecting lead:

- 2-core lead, length up to 60 m with a cross-section of 1.5 mm² (copper)
- Never route this lead immediately next to 230/400 V cables.

Specification, collector temperature sensor

Lead length	2.5 m
IP rating	IP 32 to EN 60529; ensure through design/installation.
Sensor type	Viessmann NTC 20 kΩ at 25 °C
Permissible ambient temperature	
– Operation	–20 to +200 °C
– Storage and transport	–20 to +70 °C

Cylinder temperature sensor

For connection inside the appliance
On-site extension of the connecting lead:

- 2-core lead, length up to 60 m with a cross-section of 1.5 mm² (copper)
- Never route this cable immediately next to 230/400 V cables.

Specification, cylinder temperature sensor

Lead length	3.75 m
IP rating	IP 32 to EN 60529; ensure through design/installation.
Sensor type	Viessmann NTC 10 kΩ at 25 °C
Permissible ambient temperature	
– Operation	0 to +90 °C
– Storage and transport	–20 to +70 °C

For systems with Viessmann DHW cylinders, the cylinder temperature sensor is installed in the threaded elbow in the heating water return (standard delivery or accessory for the respective DHW cylinder).

Specification, solar control module, type SM1

Rated voltage	230 V~
Rated frequency	50 Hz
Rated current	2 A
Power consumption	1.5 W
Protection class	I
IP rating	IP 20 to EN 60529; ensure through design/installation.
Function type	Type 1B to EN 60730-1
Permissible ambient temperature	
– Operation	0 to +40 °C, use in the living space or boiler room (standard ambient conditions)
– Storage and transport	–20 to +65 °C
Rated relay output breaking capacity	
– Semi-conductor relay 1	1 (1) A, 230 V~
– Relay 2	1 (1) A, 230 V~
– Total	Max. 2 A

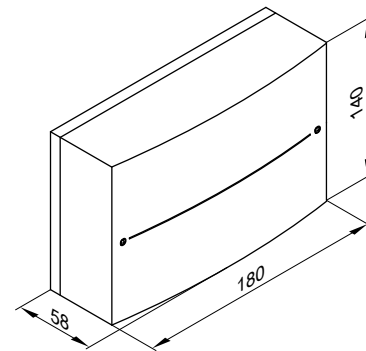

Delivered condition

- Solar control module, type SM1
- Cylinder temperature sensor
- Collector temperature sensor

Tested quality



CE designation according to current EC Directives

Vitosolic 100, type SD1, part no. Z007387

Functions

- Switching the solar circuit pump for DHW heating and/or swimming pool water heating
- Electronic limiter for the temperature in the DHW cylinder (safety shutdown at 90 °C)
- Collector safety shutdown
- General function overview: See chapter "Functions".

Design

- PCB
- Digital display
- Selection keys
- Terminals:
 - Sensors
 - Solar circuit pump
 - KM-BUS
 - Power supply (on-site ON/OFF switch)



Solar control units (cont.)

- PWM output for switching the solar circuit pump
- Relay for switching pumps and valves

Collector temperature sensor

For connection inside the appliance

On-site extension of the connecting lead:

- 2-core lead, length up to 60 m with a cross-section of 1.5 mm² (copper)
- Never route this cable immediately next to 230/400 V cables.

Specification, collector temperature sensor

Lead length	2.5 m
IP rating	IP 32 to EN 60529; ensure through design/installation.
Sensor type	Viessmann NTC 20 kΩ at 25 °C
Permissible ambient temperature	
– Operation	–20 to +200 °C
– Storage and transport	–20 to +70 °C

Cylinder temperature sensor

For connection inside the appliance

On-site extension of the connecting lead:

- 2-core lead, length up to 60 m with a cross-section of 1.5 mm² (copper)
- Never route this cable immediately next to 230/400 V cables.

Specification, cylinder temperature sensor

Lead length	3.75 m
IP rating	IP 32 to EN 60529; ensure through design/installation.
Sensor type	Viessmann NTC 10 kΩ at 25 °C
Permissible ambient temperature	
– Operation	0 to +90 °C
– Storage and transport	–20 to +70 °C

For systems with Viessmann DHW cylinders, the cylinder temperature sensor is installed in the threaded elbow in the heating water return: See chapter "Specification" of the relevant DHW cylinder and chapter "Installation accessories".

Specification Vitosolic 100, type SD1

Rated voltage	230 V~
Rated frequency	50 Hz
Rated current	4 A
Power consumption	2 W, in standby mode 0.7 W
Protection class	II
IP rating	IP 20 to EN 60529, ensure through design/installation.
Function type	Type 1B to EN 60730-1
Permissible ambient temperature	
– Operation	0 to +40 °C, use in the living space or boiler room (standard ambient conditions)
– Storage and transport	–20 to +65 °C
Rated relay output breaking capacity	
– Semi-conductor relay 1	0.8 A
– Relay 2	4(2) A, 230 V~
– Total	Max. 4 A

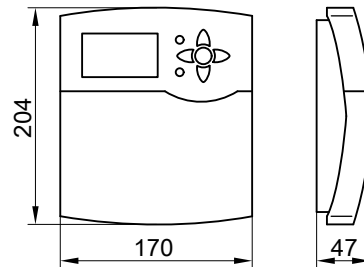

Delivered condition

- Vitosolic 100, type SD1
- Cylinder temperature sensor
- Collector temperature sensor

Tested quality



CE designation according to current EC directives

Vitosolic 200, type SD4, part no. Z007388

Functions

- Switching the solar circuit pumps for DHW and/or swimming pool water heating and other loads
- Electronic limiter for the temperature in the DHW cylinder (safety shutdown at 90 °C)
- Collector safety shutdown
- DHW and swimming pool water heating: DHW heating can be set as a priority. While heating the pool water (the lower set temperature load), the circulation pump is switched off for the duration. It can thus be determined whether the DHW cylinder (the higher set temperature load) can be recharged. If the DHW cylinder is fully heated or the temperature of the heat transfer medium is insufficient for heating the DHW cylinder, the swimming pool water will continue to be heated.
- Using the heating water buffer cylinder to heat DHW and heating water: The buffer cylinder water is heated by solar energy. The DHW water is heated by the buffer cylinder water. If the temperature in the heating water buffer cylinder exceeds the heating return temperature by the specified value, a 3-way valve is switched. The heating return water is fed via the heating water buffer cylinder to the boiler in order to raise the return temperature.
- General function overview: See chapter "Functions".

Design

- PCB
- Digital display
- Selection keys

- Terminals:
 - Sensors
 - Solar cell
 - Pumps
 - Pulse counter input for connection of flow meters
 - KM-BUS
 - Central fault message facility
 - VBus for large display
 - Power supply (on-site ON/OFF switch)
- PWM outputs for switching the solar circuit pumps

Solar control units (cont.)

- Relays for switching the pumps and valves
- Available languages:

- German
- Bulgarian
- Czech
- Danish
- English
- Spanish
- Estonian
- French
- Croatian
- Italian
- Latvian
- Lithuanian
- Hungarian
- Dutch (Flemish)
- Polish
- Russian
- Romanian
- Slovenian
- Finnish
- Serbian
- Swedish
- Turkish
- Slovak

Collector temperature sensor

For connection inside the appliance

On-site extension of the connecting lead:

- 2-core lead, length up to 60 m with a cross-section of 1.5 mm² (copper)
- Never route this cable immediately next to 230/400 V cables.

Specification, collector temperature sensor

Lead length	2.5 m
IP rating	IP 32 to EN 60529; ensure through design/installation.
Sensor type	Viessmann NTC 20 kΩ at 25 °C
Permissible ambient temperature	
– Operation	–20 to +200 °C
– Storage and transport	–20 to +70 °C

Cylinder temperature sensor or temperature sensor for swimming pool/heating water buffer cylinder

For connection inside the appliance

On-site extension of the connecting lead:

- 2-core lead, length up to 60 m with a cross-section of 1.5 mm² (copper)
- Never route this cable immediately next to 230/400 V cables.

Specification, cylinder temperature sensor

Lead length	3.75 m
IP rating	IP 32 to EN 60529; ensure through design/installation.
Sensor type	Viessmann NTC 10 kΩ at 25 °C
Permissible ambient temperature	
– Operation	0 to +90 °C
– Storage and transport	–20 to +70 °C

For systems with Viessmann DHW cylinders, the cylinder temperature sensor is installed in the threaded elbow in the heating water return: See chapter "Specification" of the relevant DHW cylinder and chapter "Installation accessories".

If the swimming pool temperature sensor is used to record the water temperature of the pool, the stainless steel sensor well available as an accessory can be installed directly in the swimming pool return line.

Specification Vitosolic 200, type SD4

Rated voltage	230 V~
Rated frequency	50 Hz
Rated current	6 A
Power consumption	6 W, in standby mode 0.9 W
Protection class	II
IP rating	IP 20 to EN 60529, ensure through design/installation.
Function type	Type 1B to EN 60730-1
Permissible ambient temperature	
– Operation	0 to +40 °C, use in the living space or boiler room (standard ambient conditions)
– Storage and transport	–20 to +65 °C
Rated relay output breaking capacity	
– Semi-conductor relay 1 to 6	0.8 A
– Relay 7	4(2) A, 230 V~
– Total	Max. 6 A

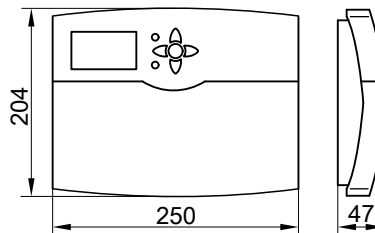

Delivered condition

- Vitosolic 200, type SD4
- Collector temperature sensor
- 2 temperature sensors

Tested quality



CE designation according to current EC Directives

6.2 Solar control units in conjunction with Vitodens 300-W, type B3HG and Vitodens 200-W, type B2HF

SDIO/SM1A electronics module

- Integrated in the DHW cylinder and Solar-Divicon
- Compatible with Viessmann control units with PlusBus or KM-BUS communication
- Automatic differentiation between PlusBus and KM-BUS subscribers

Functions with Vitodens 300-W and Vitodens 200-W via PlusBus

- Control and display via the heat generator control unit
- Switching the solar circuit pump
- Solar circuit pump speed control via PWM signal
- Suppression of DHW cylinder reheating by the heat generator subject to solar yield
- Collector safety shutdown
- Electronic temperature limitation in the DHW cylinder
- Switching of a de-stratification pump for the DHW cylinder
- Frost protection function
- Interval function
- General function overview: See chapter "Functions".

Note

Only use solar circuit pumps with PWM input.

Design

- PCB
- Terminals:
 - 4 sensors
 - Solar circuit pump
 - KM-BUS/PlusBus
 - Power supply (on-site ON/OFF switch)
- PWM output for switching the solar circuit pump
- 1 relay for switching one pump or one valve

Collector temperature sensor

Delivered separately for connecting inside the device.

On-site extension of the connecting lead:

- 2-core lead, length up to 60 m with a cross-section of 1.5 mm² (copper)
- Do not route this lead immediately next to 230/400 V cables.

Specification, collector temperature sensor

Lead length	2.5 m
IP rating	IP 32 to EN 60529; ensure through design/installation.
Sensor type	Viessmann NTC 20 kΩ at 25 °C
Permissible ambient temperature	
– Operation	–20 to +200 °C
– Storage and transport	–20 to +70 °C

Cylinder temperature sensor

The sensor is connected inside the control unit.

Specification, cylinder temperature sensor

IP rating	IP 32 to EN 60529; ensure through design/installation.
Sensor type	Viessmann NTC 10 kΩ at 25 °C
Permissible ambient temperature	
– Operation	0 to +90 °C
– Storage and transport	–20 to +70 °C

Specification, SDIO/SM1A electronics module

Rated voltage	230 V ~
Rated frequency	50 Hz
Rated current	2 A
Power consumption	1.5 W
Protection class	I
IP rating	IP 20D to EN 60529; ensure through design/installation.
Permissible ambient temperature	
– Operation	0 to +40 °C, for use in the living space or boiler room (standard ambient conditions)
– Storage and transport	–20 to +65 °C
Rated relay output breaking capacity	
– Semi-conductor relay 1	1 (1) A, 230 V~
– Relay 2	1 (1) A, 230 V~
– Total	Max. 2 A

EM-S1 extension (ADIO)

Part no. Z019336

- PlusBus subscriber
- Function extension inside enclosure for wall mounting

Functions

- Control and display via the heat generator control unit
- Switching the solar circuit pump
- Solar circuit pump speed control via PWM signal
Only use solar circuit pumps with PWM input.
- Suppression of DHW cylinder reheating by the heat generator subject to solar yield
- Collector safety shutdown

- Electronic temperature limitation in the DHW cylinder
- Switching of a transfer pump for the DHW cylinder
- Frost protection function
- Interval function
- General function overview: See chapter "Functions".

Solar control units (cont.)

Design

- PCB
- For the solar DHW heating function, the PCB provides terminals for:
 - 2 sensors
 - Solar circuit pump
 - PlusBus
 - Power supply
- PWM output for switching the solar circuit pump
- 1 relay for switching a transfer pump

Specification – EM-S1 extension

Rated voltage	230 V~
Rated frequency	50 Hz
Rated current	2 A
Power consumption	1.5 W
Protection class	I
IP rating	IP 20 to EN 60529; ensure through design/installation.
Function type	Type 1B to EN 60730-1
Permissible ambient temperature	
– Operation	0 to +40 °C, for use in the living space or boiler room (standard ambient conditions)
– Storage and transport	–20 to +65 °C
Rated relay output breaking capacity	1 A, 230 V~

Collector temperature sensor

For connection inside the appliance

On-site extension of the connecting lead:

- 2-core lead, length up to 60 m with a cross-section of 1.5 mm² (copper)
- Do not route this lead immediately next to 230 V/400 V cables.

Specification – collector temperature sensor

Lead length	2.5 m
IP rating	IP 32 to EN 60529; ensure through design/installation.
Sensor type	Viessmann NTC 20 kΩ at 25 °C
Permissible ambient temperature	
– Operation	–20 to +200 °C
– Storage and transport	–20 to +70 °C

Cylinder temperature sensor

For connection inside the appliance

On-site extension of the connecting lead:

- 2-core lead, length up to 60 m with a cross-section of 1.5 mm² (copper)
- Do not route this lead immediately next to 230/400 V cables.

Specification – cylinder temperature sensor

Lead length	3.75 m
IP rating	IP 32 to EN 60529; ensure through design/installation.
Sensor type	Viessmann NTC 10 kΩ at 25 °C
Permissible ambient temperature	
– Operation	0 to +90 °C
– Storage and transport	–20 to +70 °C

For systems with Viessmann DHW cylinders, the cylinder temperature sensor is installed in the threaded elbow in the heating water return (standard delivery or accessory for the respective DHW cylinder).

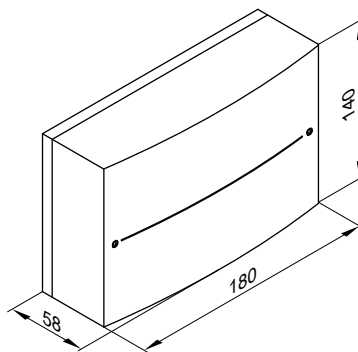

Delivered condition

- EM-S1 extension
- Cylinder temperature sensor
- Collector temperature sensor

6.3 Functions

Assignment to the solar control units

Function	SDIO/SM1A electronics module		Extension Type EM-S1	Solar control module Type SM1	Vitosolic	
	1	2			100	200
Cylinder temperature limit	X	X	X	X	X	X
Collector cooling function					X	X
Return cooling function					X	X
Collector emergency stop	X	X	X	X	X	X
Minimum collector temperature limit	X	X	X	X	X	X
Interval function	X	X	X	X	X	X
Cooling function						X
Frost protection function	X	X	X	X	X	X
Thermostat function	X	X		X	X	X
Speed control (via PWM signal)	X	X	X	X	X	X
Heat statement	X	X	X	X	X	X
Reheating suppression	X	X	X	X	X	X
Reheating suppression	X	X		X		X
Auxiliary function for DHW heating	X	X	X	X		X
External heat exchanger	X			X	X	X
Bypass function						X
Parallel relay						X
DHW cylinder 2 (to 4) ON						X
Cylinder heating						X
Cylinder priority control						X
Utilisation of excess heat						X
Cyclical heating	X			X	X	X
Fault notification via relay output						X
Relay kick	X	X	X	X		X
Saving of operating values to SD card						X
Solar central heating backup	X	X		X		X
Transfer from the solar preheat stage	X	X		X		X
Target temperature control	X			X		X
Reduction of stagnation time	X	X	X	X		
Night DHW circulation monitoring	X			X		X
Operation via boiler control unit	X	X	X	X		
dT monitoring	X	X		X		X
Setting for min./max. pump speed	X	X	X	X	Only min. pump speed adjustable	Only min. pump speed adjustable

	Functions only available in combination with Vitotronic control units (with KM-BUS)
1	With Vitotronic control units (with KM-BUS)
2	With Vitodens 300-W, type B3HG and Vitodens 200-W, type B2HF (with PlusBus)

Cylinder temperature limit

The solar circuit pump will be switched OFF if the set cylinder temperature is exceeded.

Collector cooling function

The solar circuit pump is switched off when the set cylinder temperature is reached. The solar circuit pump is switched on long enough to enable this temperature to fall by 5 K if the collector temperature rises to the selected maximum collector temperature. The cylinder temperature can then rise further, but only up to 95 °C.

Solar control units (cont.)

Return cooling function

This function only makes sense if the collector cooling function has been enabled. When the set cylinder temperature is reached, the solar circuit pump remains on to prevent the collector from overheating. In the evening, the pump will run for as long as required to cool the DHW cylinder down to the set cylinder temperature via the collector and the pipework.

Information regarding the collector cooling and reverse cooling functions

Ensure the intrinsic safety of the solar thermal system, even if the collector temperature continues to rise after the system has reached all limit temperatures, by accurately sizing the diaphragm expansion vessel. Where stagnation occurs or for collector temperatures that rise further, the solar circuit pump will be blocked or stopped (emergency collector shutdown) to avoid thermal overloading of the connected components.

Collector emergency stop

In order to protect the system components, the solar circuit pump is switched off if the adjustable collector limit temperature is exceeded. In the Vitosol-FM and 300-TM switching collectors, the collector temperature limit can be set to 145 °C. To do so, please comply with the manufacturer system pressure specification. This enables solar circuit pump operation even when the system is shut down.

Ensure the following:

- The components in the solar circuit flow line must be designed for a temperature of 145 °C.
- The return line temperature must not exceed 120 °C.

Minimum collector temperature limit

If the actual temperature falls below the minimum collector temperature, the solar circuit pump is shut down.

Interval function

Activate the interval function in systems where the collector temperature sensor is not in an ideal location to prevent a time delay in capturing the collector temperature.

Cooling function

Function for dispersing excess heat. When the set cylinder temperature and start temperature differential are reached, the solar circuit pump and relay R3 are switched on and then off when the actual temperature falls below that of the stop temperature differential.

Note

Function only available in systems with one consumer.

Frost protection

Viessmann collectors are filled with Viessmann heat transfer medium. This function does not have to be enabled.

Activate only when using water as heat transfer medium.

With a collector temperature below +5 °C, the solar circuit pump will be started to avoid damage to the collectors. The pump is stopped when a temperature of +7 °C is reached.

For Vitosolic 100/200

With a collector temperature below +4 °C, the solar circuit pump will be started to avoid damage to the collectors. The pump is stopped when a temperature of +5 °C is reached.

Thermostat function

The thermostat function can be used independent of the solar operation.

Different effects can be achieved by determining the thermostat start and stop temperatures:

- Start temperature < stop temperature:
E.g. reheating
- Start temperature > stop temperature:
E.g. utilisation of excess heat

Start temperature (40 °C) and stop temperature (45 °C) can be changed.

Start temperature setting range: 0 to 89.5 °C

Stop temperature setting range: 0.5 to 90 °C

Thermostat function, ΔT control and time switches (for Vitosolic 200)

If relays are not assigned standard functions, they can be used, for example, for function blocks 1 to 3. Within a function block, there are 4 functions that can be combined as required.

- 2 thermostat functions
- Differential temperature control
- Time switch with 3 periods that can be enabled

The functions within a function block are linked so that the conditions for all enabled functions must be met.

Thermostat function

Different effects can be achieved by determining the thermostat start and stop temperatures:

- Start temperature < stop temperature:
E.g. reheating
- Start temperature > stop temperature:
E.g. utilisation of excess heat

Start temperature (40 °C) and stop temperature (45 °C) can be changed.

Solar control units (cont.)

Start temperature and stop temperature setting range: -40 to 250 °C

ΔT controls

The corresponding relay switches ON if the start temperature differential is exceeded and OFF if the stop temperature is not achieved.

Speed control (via PWM signal)

The speed of the solar circuit pump is controlled by means of the temperature differential between the collector temperature and the cylinder temperature.

Suitable pumps:

- High efficiency circulation pumps
- Pumps with PWM input (only use solar circuit pumps)

Heat statement

When determining thermal yields, the difference between the collector and cylinder temperature, the set throughput, the type of heat transfer medium and the operating time of the solar circuit pump are taken into account.

For Vitosolic 200

The statement can be produced with or without the flow meter.

- Without flow meter
Through the temperature differential between the heat meter flow and the heat meter return temperature sensor and the selected throughput
- With flow meter
Through the temperature differential between the heat meter flow and the heat meter return temperature sensor and the throughput captured by the flow meter

Reheating suppression

DHW cylinder reheating by the boiler is suppressed in 2 stages. During solar heating of the DHW cylinder, the set cylinder temperature is reduced. Suppression remains active for a certain time after the solar circuit pump is switched off.

Systems with KM-BUS

If solar heating is uninterrupted (> 2 h), reheating by the boiler only occurs if the temperature falls below the 3rd set DHW temperature, as set at the boiler control unit (at coding address "67") (setting range 10 to 95 °C). This value must be **below** the 1st set DHW temperature.

If the solar thermal system is unable to maintain this set value, the DHW cylinder is heated by the boiler (solar circuit pump running).

Systems with PlusBus

If solar heating is uninterrupted (> 2 h), reheating by the boiler only occurs if the temperature falls below the 3rd set DHW temperature, as set at the boiler control unit (in parameter "1394.0") (setting range 10 to 95 °C). This value must be **below** the 1st set DHW temperature.

If the solar thermal system is unable to maintain this set value, the DHW cylinder is heated by the boiler (solar circuit pump running).

Reheating suppression

If a sufficiently high temperature is available in the multi mode heating water buffer cylinder to heat the heating circuits, reheating is suppressed.

Auxiliary function for DHW heating

In solar thermal systems with DHW storage, we recommend heating the preheating cylinder and the preheating stage in dual mode DHW cylinders to ≥ 60 °C once a day (regardless of the cylinder volume).

Time switch

The corresponding relay switches ON at the start-up time and OFF at the shutdown time (3 time windows can be activated).

Note

We recommend operating the solar circuit pump at max. output while the solar thermal system is being vented.

For Vitosolic 200

Speed control can be enabled/disabled for relay outputs R1 to R4.

Existing sensors can be used, without affecting their function in the relevant system scheme.

For Vitosolic 100/200

Systems with KM-BUS

Reheating of the DHW cylinder by the boiler will be suppressed by the solar control unit if the DHW cylinder is being heated.

Coding address "67" in the boiler control unit specifies a 3rd set DHW temperature (setting range 10 to 95 °C). This value must be **below** the 1st set DHW temperature.

If the solar thermal system is unable to maintain this set value, the DHW cylinder is heated by the boiler (solar circuit pump running).

Systems with PlusBus and additional Viessmann control units

Reheating of the DHW cylinder by the boiler will be suppressed by the solar control unit if the DHW cylinder is being heated. A resistor simulates an actual DHW temperature that is approx. 10 K higher.

If the solar thermal system is unable to maintain the set DHW temperature, the DHW cylinder is heated by the boiler (solar circuit pump running).

Systems with KM-BUS

Enabling the auxiliary function for DHW heating must be encoded at the boiler control unit. The solar preheat stage can be heated up at selectable times.

Solar control units (cont.)

Boiler control unit settings:

- Set DHW temperature 2 must be encoded
- DHW phase 4 for DHW heating must be enabled

Systems with PlusBus

Enabling the auxiliary function for DHW heating must be encoded at the boiler control unit. The solar preheat stage can be heated up at selectable times.

For Vitosolic 200

Systems with KM-BUS

This signal is then relayed via the KM-BUS to the solar control unit. The de-stratification pump is started at an adjustable time, if the DHW cylinder has not reached 60 °C at least once per day.

Systems with PlusBus and additional Viessmann control units

The de-stratification pump is started at an adjustable time, if the DHW cylinder has not reached 60 °C at least once per day. A resistor simulates a DHW temperature of approx. 35 °C. The transfer pump is connected to relay output R3 or R5, irrespective of which relays are already assigned standard functions.

External heat exchanger

- The DHW cylinder is heated via the heat exchanger. The secondary pump on the DHW side is started in parallel with the solar circuit pump.
- Optionally, an additional temperature sensor at the plate heat exchanger can be used.

For Vitosolic 200

In systems with several consumers, either an individual or all consumers can be heated via the external heat exchanger. The consumers will be heated up to no more than the selected set temperature (delivered condition 60 °C).

For Vitosolic 100

The DHW cylinder is heated via the heat exchanger. The secondary pump on the DHW side is started in parallel with the solar circuit pump.

Bypass function

To improve the start-up characteristics of the system or for frost protection with an external heat exchanger, we recommend operation with a bypass circuit.

Parallel relay

With this function, a further relay will be switched (subject to the system scheme) in parallel to the relay that switches the circulation pump of a solar consumer, e.g. to control a diverter valve.

DHW cylinder 2 (to 4) ON

In systems with several consumers. With this function, consumers can be excluded from solar heating.

Any break or short circuit of the cylinder temperature sensor is then **no longer** reported.

Cylinder heating

This function heats a consumer within a certain range. This range is determined by the sensor positions.

Cylinder priority control

In systems with several consumers.

It is possible to determine the order for heating the consumers.

Utilisation of excess heat

In systems with several consumers.

A consumer can be selected to be heated only once all other consumers have reached their set value. The selected consumer will not be heated in cyclical operation.

Cyclical heating

In systems with several consumers.

If the consumer cannot be heated with priority, the next consumer in line will be heated for an adjustable cycle time. After this time has expired, the solar control unit checks the rise of the collector temperature during the adjustable cyclical pause. As soon as the start conditions for the consumer with priority have been met, that consumer will be heated again. Otherwise, the next-in-line consumers will continue to be heated.

Solar control units (cont.)

Fault notification via relay output

A central fault message facility can be connected to floating relay output R7. Relay R7 must be activated as a signalling relay and is then not available for any other function.

Relay kick

If the pumps and valves have been switched off for 24 hours, they are started for approx. 10 s to prevent them seizing up.

For Vitosolic 200

The period for relay kick must be set.

Saving of operating values to SD card

SD card to be provided on site with a memory capacity ≤ 32 GB and file system FAT16

Note

Never use SD-HD cards.

The SD card is inserted into the Vitosolic 200.

- To record the operating values of the solar thermal system
- Saving the values to the module in a text file. The text file can be opened, e.g. using a spreadsheet program. The values can therefore also be displayed graphically.

Solar central heating backup

Depending on the position of the 3-way valve, the heating circuits are either supplied directly via the primary heat generator, or the heating circuit return is fed into the solar thermally heated heating water buffer cylinder and heated there. If solar thermal heating is insufficient, the water is heated further in the boiler.

Transfer from the solar preheat stage

The second differential temperature control is for the transfer from the solar preheat stage to the DHW cylinder heated by the boiler if the temperature in the preheat stage is higher than that in the DHW cylinder heated by the boiler. In addition, the preheat stage can be thermally disinfected (legionella protection).

Target temperature control

Heating water buffer cylinders with a stratification system should be optimally heated with the aid of a target temperature control. Provided the temperature is sufficiently high, solar-thermally heated water can be transferred directly into the upper section of the heating water buffer cylinder with the stratification system. This results in reduced reheating.

Reduction of stagnation time

If there is an excess of solar energy, the speed of the solar circuit pump is reduced before the maximum cylinder temperature is reached. This causes an increase in the differential between collector temperature and cylinder temperature. The heat transfer to the DHW cylinder is reduced, which delays stagnation.

Night DHW circulation monitoring

Unwanted flow in the solar circuit (e.g. at night) is captured. For this, the night-time collector temperature must exceed the outside temperature by 10 K. The captured situations with unwanted flow are reported to the control unit of the heat source. The situations can be called up under "Diagnosis solar" (weather-compensated control unit) or "Brief scan" (constant temperature control unit).

Operation via boiler control unit

The solar thermal system is operated via the display on the heat generator control unit. The solar control units have neither a dedicated display nor a dedicated programming unit. All settings are made via the heat generator control unit.

dT monitoring

If the solar circuit pump is active or the differential between the collector temperature and the cylinder temperature becomes too high, the system reports a fault.

Setting for min./max. pump speed

The setting of the min. and max. speeds of the solar circuit pump can be influenced. The solar circuit pump can therefore be adapted to the specific system.

Solar control units (cont.)

6.4 Accessories

Allocation to solar control units

	Part no.	SDIO/SM1A electronics module		Extension type EM-S1	Solar control module, type SM1	Vitosolic	
		1	2			100	200
Contactor relay	7814681					X	X
Immersion temperature sensor	7438702	X			X		
Immersion temperature sensor	7426247					X	X
Collector temperature sensor	7831913						X
Stainless steel sensor well	7819693	X	X	X	X	X	X
Heat meter							
– Heat meter 15	7418207						X
– Heat meter 25	7418208						X
– Heat meter 35	7418209						X
– Heat meter 60	7418210						X
Solar cell	7408877						X
Large display	7438325						X
High limit safety cut-out	Z001889	X	X	X	X	X	X
Pressure switch	ZK03781	X	X	X	X	X	X
Temperature controller as temperature limiter (maximum limit)	Z001887						X
Temperature controller	7151989	X	X	X	X	X	X
Temperature controller	7151988	X	X	X	X	X	X

1	With Vitotronic control units (with KM-BUS)
2	With Vitodens 300-W, type B3HG and Vitodens 200-W, type B2HF (with PlusBus)

Contactor relay

Part no. 7814681

- Contactor in small enclosure
- With 4 N/C and 4 N/O contacts
- With terminal strips for earth conductors

Specification

Coil voltage	230 V/50 Hz
Rated current (I_{th})	AC1 16 A AC3 9 A

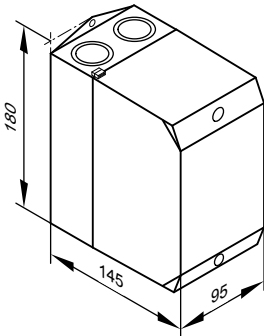

Immersion temperature sensor

Immersion temperature sensor

Part no. 7438702

To capture a temperature in a sensor well

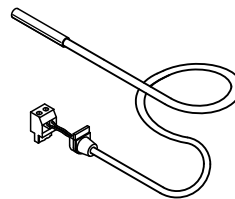

Solar control units (cont.)

Specification

Lead length	5.8 m, fully wired
IP rating	IP 32 to EN 60529; ensure through design/installation.
Sensor type	Viessmann NTC 10 kΩ, at 25 °C
Permissible ambient temperature	
– Operation	0 to +90 °C
– Storage and transport	–20 to +70 °C

- For DHW circulation changeover in systems with 2 DHW cylinders
- For return changeover between the boiler and the heating water buffer cylinder
- For heating additional consumers

Immersion temperature sensor

Part no. 7426247

For installation in the DHW cylinder, heating water buffer cylinder, combi cylinder

- For DHW circulation diversion in systems with 2 DHW cylinders
- For return changeover between the boiler and the heating water buffer cylinder

- For heating additional consumers
 - For a heat statement (return temperature is captured)
- On-site extension of the connecting lead:
- 2-core lead, length up to 60 m with a cross-section of 1.5 mm² (copper)
 - Never route this cable immediately next to 230/400 V cables.

Specification

Lead length	3.8 m
IP rating	IP 32 to EN 60529; ensure through design/installation
Sensor type	Viessmann NTC 10 kΩ, at 25 °C
Permissible ambient temperature	
– Operation	0 to +90 °C
– Storage and transport	–20 to +70 °C

Collector temperature sensor

Part no. 7831913

Immersion temperature sensor for installation in the solar collector

- For systems with 2 collector arrays
- For heat statement (recording flow temperature)

On-site extension of the connecting lead:

- 2-core lead, length up to 60 m with a cross-section of 1.5 mm² (copper)
- Never route this lead immediately next to 230/400 V cables.

Specification

Lead length	2.5 m
IP rating	IP 32 to EN 60529; ensure through design/installation
Sensor type	Viessmann NTC 20 kΩ at 25 °C
Permissible ambient temperature	
– Operation	–20 to +200 °C
– Storage and transport	–20 to +70 °C

Stainless steel sensor well

Part no. 7819693

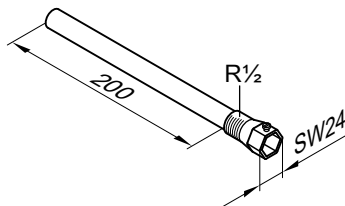

For temperature controllers and temperature sensors.
Part of the standard delivery of the Viessmann DHW cylinders.

Heat meter

Components:

- 2 sensor wells
- Flow meter with connection fitting to capture the flow rate of water: glycol mixtures (Viessmann heat transfer medium "Tyfo-cor LS" with 45 % glycol volume ratio):

Solar control units (cont.)

Heat meter

15 Part no. 7418207
25 Part no. 7418208

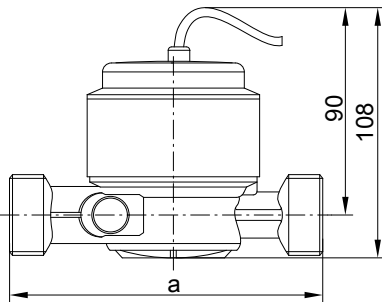

35 Part no. 7418209
60 Part no. 7418210

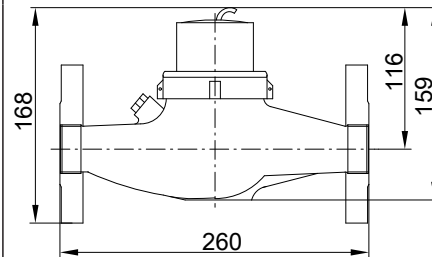

Specification

Permissible ambient temperature

- During operation 0 to +40 °C
 - During storage and transport -20 to +70 °C
- Setting range for glycol volume ratio 0 to 70 %

Flow meter

		15	25	35	60
Dimension a in mm		110	130	—	—
Pulse rate	l/imp.	1	25	25	25
Internal diameter	DN	15	20	25	32
Connection thread at the meter	R	¾	1	1¼	1½
Connection thread at the fitting	R	½	¾	1	1¼
Max. operating pressure	bar	16	16	16	16
Max. operating temperature	°C	120	120	130	130
Sensor wells G½ x	mm	45	60	60	60
The following details refer to the water flow rate. If glycol mixtures are used, the different viscosities will result in deviations.					
Nominal flow rate	m³/h	0.6 - 1.5	2.5	3.5	6.0
Peak flow rate	m³/h	3	5	7	12
Cut point ±3 %	l/h	120	200	280	480
Lowest flow rate (horizontal installation)	l/h	30	50	70	120
Lowest flow rate (vertical installation)	l/h	60	100	—	—
Pressure drop at approx. ¾ of the nominal flow rate	bar	0.1	0.1	0.1	0.1

Solar cell

Part no. 7408877

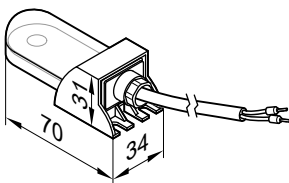

The solar cell captures the intensity of the sun and communicates this to the solar control unit. The bypass pump will be switched ON if the insolation exceeds the set switching threshold.

With connecting cable, 2.3 m long.

On-site extension of the connecting lead:

2-core lead, length max. 35 m with a cross-section of 1.5 mm² (copper).

Large display

Part no. 7438325

To visualise the collector and cylinder temperatures as well as the energy yield.

With power supply unit plug.

Solar control units (cont.)

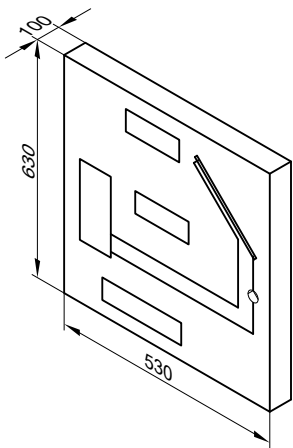

Specification

Power supply	9 V– plug power supply unit 230 V~, 50 to 60 Hz
Power consumption	max. 12 VA
BUS connection	V BUS
IP rating	IP 30 (in dry rooms)
Permissible ambient temperature during operation, storage and transport	0 to 40 °C

High limit safety cut-out

Part no. Z001889

- With a thermostatic system
- With stainless steel sensor well R½ x 200 mm
- With setting scale and reset button in the casing
- Required if less than 40 l cylinder capacity is available per m² absorber area. This reliably prevents temperatures above 95 °C in the DHW cylinder.

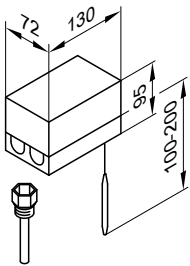

Specification

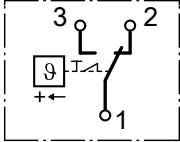
Connection	3-core lead with a cross-section of 1.5 mm ²
IP rating	IP 41 to EN 60529
Switching point	120 (110, 100, 95) °C
Switching differential	max. 11 K
Breaking capacity	6(1.5) A, 250 V~
Switching function	with rising temperature from 2 to 3 
DIN reg. no.	DIN STB 1169

Pressure switch

Part no. ZK03781

Suitable for all solar circuits

For monitoring system pressure in the solar circuit (leaks). Use in water conservation areas and with solar thermal systems with solar medium capacity > 220 l against the backdrop of the Regulation on Handling Substances Hazardous to Water (AwSV).

- Adjustable pressure monitor (e.g. 0 to 10 bar)
- Adjustable between 5 and 90 % of nominal pressure

- With floating alarm contact
- Compatible with Viessmann heat transfer medium (Tyfocor L/LS)
- Operating medium connections G ¼
- Max. operating temperature 120 °C

Temperature controller as temperature limiter (maximum limit)

Part no. Z001887

With stainless steel sensor well R½ x 200 mm.

With setting scale in the casing.

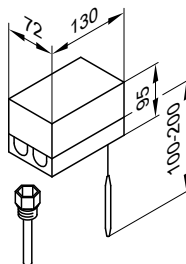

Solar control units (cont.)

Specification

Connection	3-core lead with a cross-section of 1.5 mm ²
Setting range	30 to 80 °C
Switching differential	Max. 11 K
Breaking capacity	6(1.5) A 250 V~

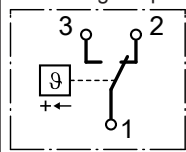
Switching function	With rising temperature from 2 to 3 
DIN reg. no.	DIN TR 1168

Temperature controller

Part no. 7151989

Suitable for:

- Vitocell 100-B
 - Vitocell 100-V
 - Vitocell 340-M
 - Vitocell 360-M
- With a thermostatic system
 - With selector on the outside of the casing
 - Without sensor well
 - With top-hat rail to be fitted to the DHW cylinder or the wall

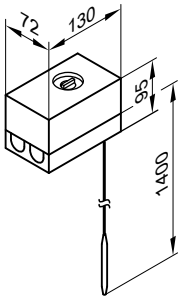

Specification

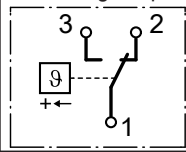
Connection	3-core lead with a cross-section of 1.5 mm ²
IP rating	IP 41 to EN 60529
Setting range	30 to 60 °C, adjustable up to 110 °C
Switching differential	Max. 11 K
Breaking capacity	6 (1.5) A 250 V~
Switching function	With rising temperature from 2 to 3 
DIN registration number	DIN TR 1168

Temperature controller

Part no. 7151988

Suitable for:

- Vitocell 300-B
 - Vitocell 300-V
- With a thermostatic system
 - With selector on the outside of the casing
 - Without sensor well
- Suitable for sensor well part no. 7819693
 The sensor well is part of the standard delivery of DHW cylinders from Viessmann.

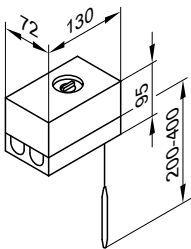

Specification

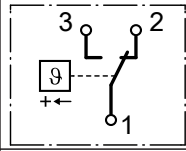
Connection	3-core lead with a cross-section of 1.5 mm ²
IP rating	IP 41 to EN 60529
Setting range	30 to 60 °C, adjustable up to 110 °C
Switching differential	max. 11 K
Breaking capacity	6(1.5) A 250 V~
Switching function	with rising temperature from 2 to 3 
DIN reg. no.	DIN TR 1168

DHW cylinders

7.1 Vitocell 100-U, type CVUB/CVUB-A

With installed Solar-Divicon and electronics module SDIO/SM1A or Vitosolic 100 (type SD1)

Vitocell 100-U, colour: Vitosilver

For DHW heating in conjunction with boilers and solar collectors.

Suitable for the following systems:

- DHW temperature up to **95 °C**
- Heating water flow temperature up to **160 °C**
- Solar flow temperature up to **110 °C**
- Operating pressure **on the heating water side up to 10 bar (1.0 MPa)**
- Operating pressure **on the solar side up to 10 bar (1.0 MPa)**
- Operating pressure **on the DHW side up to 10 bar (1.0 MPa)**

Vitocell 100-W, colour: Vitopearlwhite

Specification

Type		CVUB	CVUB-A
Cylinder capacity (AT: Actual water capacity)	l	300	
Heating water capacity			
– Upper indirect coil	l	6	
– Lower indirect coil	l	10	
Gross volume	l	316	
DIN registration no.		0266/07-13MC/E	
Continuous output, upper indirect coil			
For DHW heating from 10 to 45 °C and a heating water flow temperature of ... at the heating water flow rate stated below	90 °C	kW l/h	31 761
	80 °C	kW l/h	26 638
	70 °C	kW l/h	20 491
	60 °C	kW l/h	15 368
	50 °C	kW l/h	11 270
Continuous output, upper indirect coil			
For DHW heating from 10 to 60 °C and a heating water flow temperature of ... at the heating water flow rate stated below	90 °C	kW l/h	23 395
	80 °C	kW l/h	20 344
	70 °C	kW l/h	15 258
Heating water flow rate for the stated continuous outputs		m ³ /h	3.0
Draw-off rate		l/min	15
Drawable water volume	l	110	
Without reheating Cylinder content heated to 60 °C Water at t = 60 °C (constant)			
Standby heat loss	kWh/24 h	1.52	1.15
Standby capacity V_{aux}	l	127	
Solar capacity V_{sol}	l	173	
Dimensions (incl. thermal insulation)			
Length a (∅)	mm	660	
Total width b	mm	840	
Height c	mm	1735	
Height when tilted	mm	1830	
Weight incl. thermal insulation	kg	179	
Total weight in operation	kg	481	
Heating surface			
– Upper indirect coil	m ²	0.9	
– Lower indirect coil	m ²	1.5	
Connections (male thread)			
Heating water flow and return	R	1	
Cold water, DHW	R	1	
DHW circulation	R	1	
Energy efficiency class		B	A

DHW cylinders (cont.)

Information regarding continuous output of the upper indirect coil

When engineering systems with the specified or calculated continuous output, select a matching circulation pump. The stated continuous output is only achieved when the rated boiler heating output \geq continuous output.

Take the following into account when sizing entry points:

The actual dimensions of the DHW cylinder may vary slightly due to manufacturing tolerances.

Dimensions

Dimension	mm
a	660
b	840
c	1735

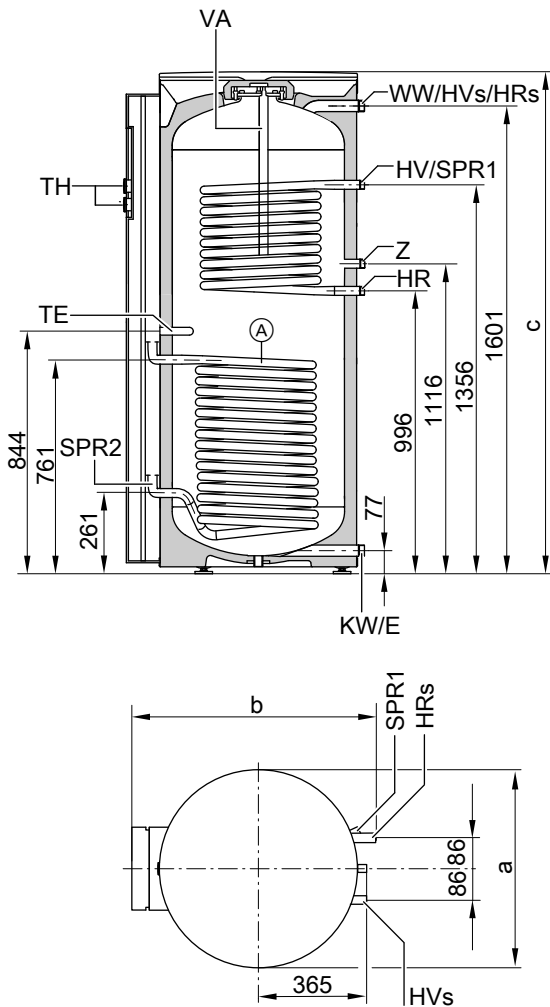

- Ⓐ Lower indirect coil (solar thermal system)
The connections HV_s and HR_s are located on the top of the DHW cylinder.
- E Drain outlet
- HR Heating water return
- HR_s Heating water return, solar thermal system
- HV Heating water flow
- HV_s Heating water flow, solar thermal system
- KW Cold water
- SPR1 Sensor well for cylinder temperature sensor of cylinder temperature controller (internal diameter 16 mm)
- SPR2 Sensor well for cylinder temperature sensor of solar thermal system (internal diameter 16 mm)
- TE Sensor well (internal diameter 16 mm)
- TH Thermometer
- VA Protective magnesium anode
- WW DHW
- Z DHW circulation

5822440

DHW cylinders (cont.)

Cylinder temperature sensor for solar operation

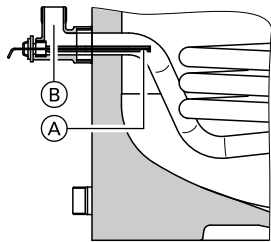

Arrangement of cylinder temperature sensor in the heating water return HR_s

- (A) Cylinder temperature sensor (standard delivery of the Solar-Set)
- (B) Threaded elbow with sensor well (standard delivery, internal diameter 6.5 mm)

Performance factor N_L

To DIN 4708.

Upper indirect coil.

Cylinder storage temperature

$T_{cyl} = \text{cold water inlet temperature} + 50 \text{ K}^{+5 \text{ K}/-0 \text{ K}}$

Performance factor N_L at heating water flow temperature

90 °C	1.6
80 °C	1.5
70 °C	1.4

Information regarding performance factor N_L

The performance factor N_L depends on the cylinder storage temperature T_{cyl} .

Standard values

- $T_{cyl} = 60 \text{ °C} \rightarrow 1.0 \times N_L$
- $T_{cyl} = 55 \text{ °C} \rightarrow 0.75 \times N_L$
- $T_{cyl} = 50 \text{ °C} \rightarrow 0.55 \times N_L$
- $T_{cyl} = 45 \text{ °C} \rightarrow 0.3 \times N_L$

Peak output (over 10 minutes)

Relative to the performance factor N_L .

DHW heating from 10 to 45 °C.

Peak output (l/10 min) at a heating water flow temperature of

90 °C	173
80 °C	168
70 °C	164

Max. draw-off rate (over 10 minutes)

Relative to the performance factor N_L .

With reheating.

DHW heating from 10 to 45 °C.

Max. draw-off rate (l/min) at heating water flow temperature

90 °C	17
80 °C	17
70 °C	16

DHW cylinders (cont.)

Heat-up time

The specified heat-up times will be achieved subject to the maximum continuous output of the DHW cylinder being made available at the relevant heating water flow temperature and when DHW is heated from 10 to 60 °C.

Heat-up time (min.) at heating water flow temperature

90 °C	16
80 °C	22
70 °C	30

Pressure drop on the heating water side, upper indirect coil

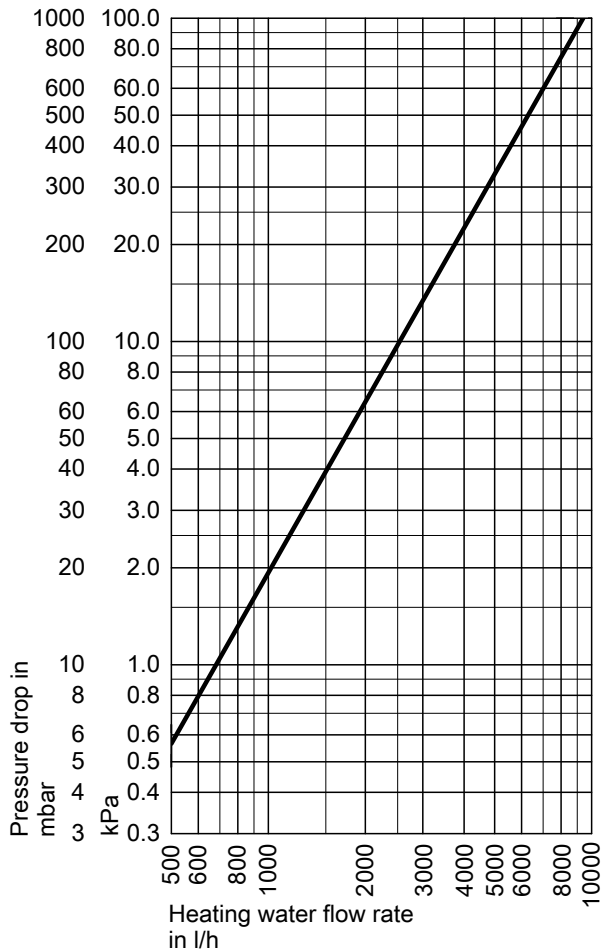

Pressure drop on the DHW side

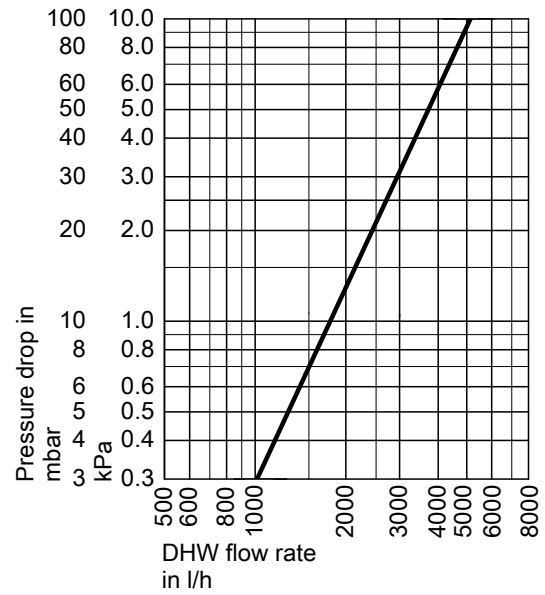

DHW cylinders (cont.)

7.2 Vitocell 100-B, type CVB/CVBB

For DHW heating in conjunction with boilers and solar collectors for dual mode operation

Suitable for the following systems:

- DHW temperature up to **95 °C**
- Heating water flow temperature up to **160 °C**
- Solar flow temperature up to **160 °C**

- Operating pressure on the heating water side up to **10 bar (1.0 MPa)**
- Operating pressure on the solar side up to **10 bar (1.0 MPa)**
- Operating pressure on the DHW side up to **10 bar (1.0 MPa)**

Vitocell 100-W, colour: White (300 and 400 l)

Vitocell 100-B, colour: Vitosilver

Specification

Type		CVBB		CVB		CVB		CVBB		CVBB		
Cylinder capacity	l	300		400		500		750		950		
(AT: Actual water capacity)												
Internal indirect coil		Top	Bot- tom	Top	Bot- tom	Top	Bot- tom	Top	Bot- tom	Top	Bottom	
Heating water capacity	l	6	10	6.5	10.5	9	12.5	13.8	29.7	18.6	33.1	
Gross volume	l	316	316	417	417	521.5	521.5	795.5	795.5	1001.7	1001.7	
DIN registration no.		9W242/11-13 MC/E						Applied for				
Continuous output For DHW heating from 10 to 45 °C and a heating water flow temperature of ... at the heating water flow rate stated below	90 °C	kW	31	53	42	63	47	70	76	114	90	122
		l/h	761	1302	1032	1548	1154	1720	1866	2790	2221	2995
	80 °C	kW	26	44	33	52	40	58	63	94	75	101
		l/h	638	1081	811	1278	982	1425	1546	2311	1840	2482
	70 °C	kW	20	33	25	39	30	45	49	73	58	78
		l/h	491	811	614	958	737	1106	1200	1794	1428	1926
60 °C	kW	15	23	17	27	22	32	35	52	41	56	
	l/h	368	565	418	663	540	786	853	1275	1015	1369	
50 °C	kW	11	18	10	13	16	24	26	39	31	42	
	l/h	270	442	246	319	393	589	639	955	760	1026	
Continuous output For DHW heating from 10 to 60 °C and a heating water flow temperature of ... at the heating water flow rate stated below	90 °C	kW	23	45	36	56	36	53	59	79	67	85
		l/h	395	774	619	963	619	911	1012	1359	1157	1465
	80 °C	kW	20	34	27	42	30	44	49	66	56	71
	l/h	344	584	464	722	516	756	840	1128	960	1216	
	70 °C	kW	15	23	18	29	22	33	37	49	42	53
	l/h	258	395	310	499	378	567	630	846	720	912	
Heating water flow rate for the stated continuous outputs	m ³ /h	3.0		3.0		3.0		3.0		3.0		
Max. connectible heat pump output At 55 °C heating water flow temperature and 45 °C DHW temperature for the specified heating water flow rate (both internal indirect coils connected in series)	kW	10		12		14		21		23		
Standby heat loss	kWh/24 h	1.65		1.80		1.95		2.28		2.48		
Standby capacity V _{aux}	l	127		167		231		365		500		
Solar capacity V _{sol}	l	173		233		269		385		450		
Dimensions												
Length (∅)												
– incl. thermal insulation	a	mm	667		859		859		1062		1062	
– excl. thermal insulation		mm	–		650		650		790		790	
Total width												
– incl. thermal insulation	b	mm	744		923		923		1110		1110	
– excl. thermal insulation		mm	–		881		881		1005		1005	
Height												
– incl. thermal insulation	c	mm	1734		1624		1948		1897		2197	
– excl. thermal insulation		mm	–		1518		1844		1797		2103	
Height when tilted												
– incl. thermal insulation		mm	1825		–		–		–		–	
– excl. thermal insulation		mm	–		1550		1860		1980		2286	
Entire weight incl. thermal insulation		kg	166		167		205		320		390	
Total weight in operation incl. immersion heater		kg	468		569		707		1072		1342	
Heating surface		m ²	0.9	1.5	1.0	1.5	1.4	1.9	1.6	3.5	2.2	3.9

DHW cylinders (cont.)

Type		CVBB	CVB	CVB	CVBB	CVBB
Cylinder capacity (AT: Actual water capacity)	I	300	400	500	750	950
Connections						
Upper indirect coil (male thread)	R	1	1	1	1	1
Lower indirect coil (male thread)	R	1	1	1	1¼	1¼
Cold water, DHW (male thread)	R	1	1¼	1¼	1¼	1¼
DHW circulation (male thread)	R	1	1	1	1¼	1¼
Immersion heater (female thread)	Rp	1½	1½	1½	–	–
Energy efficiency class		B	B	B	–	–

Notes on the upper indirect coil

The upper indirect coil is designed for connection to a heat generator.

Notes on the lower indirect coil

The lower indirect coil is designed for connection to solar collectors. To install the cylinder temperature sensor, use the threaded elbow with sensor well included in the standard delivery.

Notes on continuous output

When designing systems with the specified or calculated continuous output, select the appropriate circulation pump. The stated continuous output is achieved only if the rated boiler heating output is \geq the continuous output.

Take the following into account when sizing entry points:

The actual dimensions of the DHW cylinder may vary slightly due to manufacturing tolerances.

DHW cylinders (cont.)

Vitocell 100-B/100-W, type CVBB, 300 l capacity

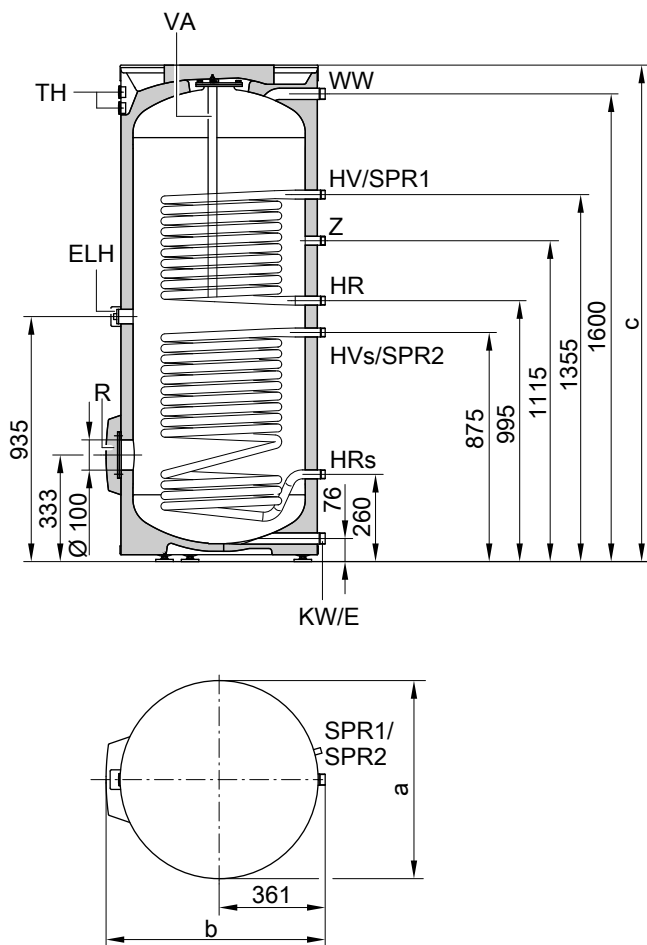

Table of dimensions

Cylinder capacity	l	300
a	mm	667
b	mm	744
c	mm	1734

- E Drain
- ELH Immersion heater
- HR Heating water return
- HR_s Heating water return, solar thermal system
- HV Heating water flow
- HV_s Heating water flow, solar thermal system
- KW Cold water
- R Inspection and cleaning aperture with flange cover (also suitable for installation of an immersion heater)
- SPR1 Cylinder temperature sensor for cylinder temperature controller (internal diameter 16 mm)
- SPR2 Temperature sensors/thermometers (internal diameter 16 mm)
- TH Thermometer (accessories)
- VA Protective magnesium anode
- WW DHW
- Z DHW circulation

DHW cylinders (cont.)

Vitocell 100-B/100-W, type CVB, 400 and 500 l capacity

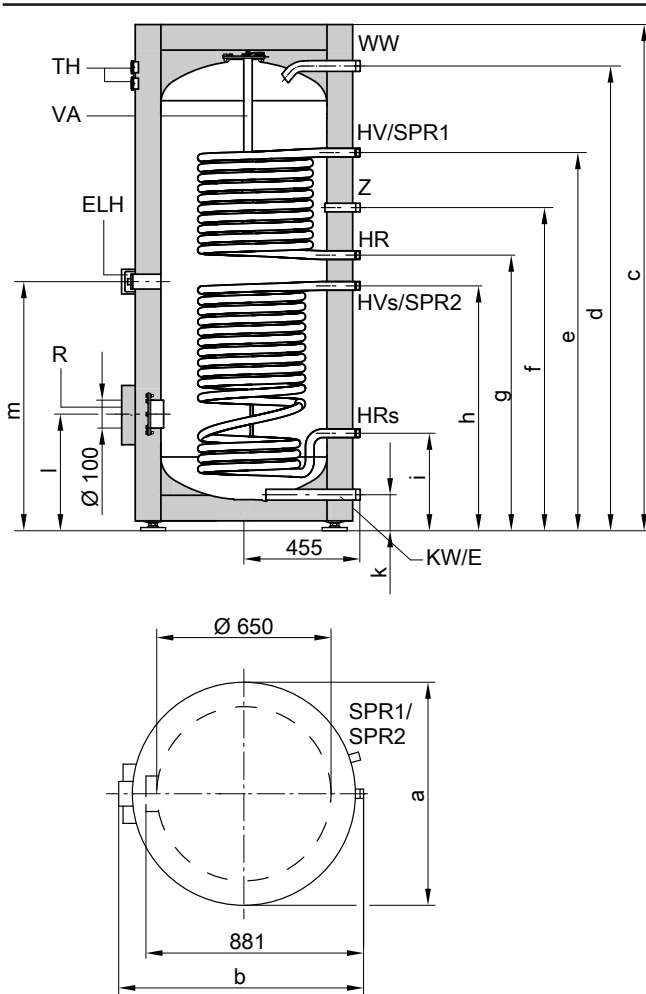

Table of dimensions

Cylinder capacity	l	400	500
a	mm	859	859
b	mm	923	923
c	mm	1624	1948
d	mm	1458	1784
e	mm	1204	1444
f	mm	1044	1230
g	mm	924	1044
h	mm	804	924
i	mm	349	349
k	mm	107	107
l	mm	422	422
m	mm	864	984

- E Drain
- ELH Immersion heater
- HR Heating water return
- HR_s Heating water return, solar thermal system
- HV Heating water flow
- HV_s Heating water flow, solar thermal system
- KW Cold water
- R Inspection and cleaning aperture with flange cover (also suitable for installation of an immersion heater)
- SPR1 Cylinder temperature sensor for cylinder temperature controller (internal diameter 16 mm)
- SPR2 Temperature sensors/thermometers (internal diameter 16 mm)
- TH Thermometer (accessories)
- VA Protective magnesium anode
- WW DHW
- Z DHW circulation

DHW cylinders (cont.)

Vitocell 100-B, type CVBB, 750 and 950 l capacity

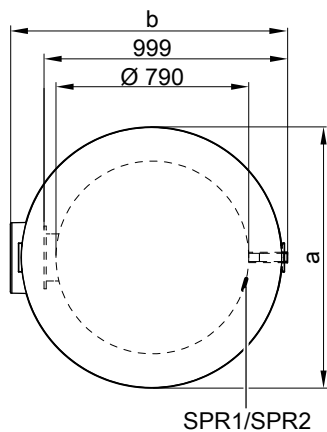
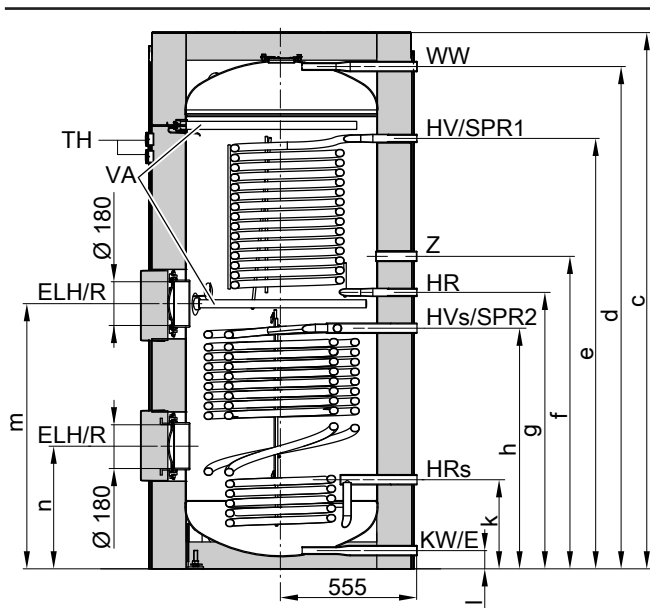

Table of dimensions

Cylinder capacity	l	750	950
a	mm	1062	1062
b	mm	1110	1110
c	mm	1897	2197
d	mm	1749	2054
e	mm	1464	1760
f	mm	1175	1278
g	mm	1044	1130
h	mm	912	983
k	mm	373	363
l	mm	74	73
m	mm	975	1084
n	mm	509	501

- E Drain
- ELH Immersion heater or heating lance
- HR Heating water return
- HR_s Heating water return, solar thermal system
- HV Heating water flow
- HV_s Heating water flow, solar thermal system
- KW Cold water
- R Inspection and cleaning aperture with flange cover
- SPR1 Clamping device for securing immersion temperature sensors to the cylinder jacket (up to 3 immersion temperature sensors)
- SPR2 Clamping device for securing immersion temperature sensors to the cylinder jacket (up to 3 immersion temperature sensors)
- TH Thermometer (accessories)
- VA Protective magnesium anode
- WW DHW
- Z DHW circulation

DHW cylinders (cont.)

Cylinder temperature sensor for solar operation

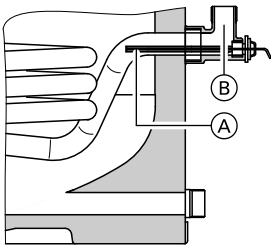

Arrangement of cylinder temperature sensor in the heating water return HR_s

- (A) Cylinder temperature sensor (standard delivery of solar control unit)
- (B) Threaded elbow with sensor well (standard delivery, internal diameter 6.5 mm)

Performance factor N_L

- To DIN 4708
- Upper indirect coil
- Cylinder storage temperature T_{cyl} = cold water inlet temperature + 50 K ^{+5 K/-0 K}

Cylinder capacity	l	300	400	500	750*2	950*2
Performance factor N_L						
at heating water flow temperature						
90 °C		1.6	3.0	6.0	8.0	11.0
80 °C		1.5	3.0	6.0	8.0	11.0
70 °C		1.4	2.5	5.0	7.0	10.0

Notes on performance factor N_L

The performance factor N_L changes in line with the cylinder storage temperature T_{cyl} .

Standard values

- $T_{cyl} = 60\text{ °C} \rightarrow 1.0 \times N_L$
- $T_{cyl} = 55\text{ °C} \rightarrow 0.75 \times N_L$
- $T_{cyl} = 50\text{ °C} \rightarrow 0.55 \times N_L$
- $T_{cyl} = 45\text{ °C} \rightarrow 0.3 \times N_L$

Peak output (over 10 minutes)

- Relative to performance factor N_L
- DHW heating from 10 to 45 °C

Cylinder capacity	l	300	400	500	750*2	950*2
Peak output						
at heating water flow temperature						
90 °C	l/10 min	173	230	319	438	600
80 °C	l/10 min	168	230	319	438	600
70 °C	l/10 min	164	210	299	400	550

Max. draw-off rate (over 10 minutes)

- Relative to performance factor N_L
- With reheating
- DHW heating from 10 to 45 °C

Cylinder capacity	l	300	400	500	750*2	950*2
Max. draw-off rate						
at heating water flow temperature						
90 °C	l/min	17	23	32	44	60
80 °C	l/min	17	23	32	44	60
70 °C	l/min	16	21	30	40	55

*2 Values determined by calculation.

DHW cylinders (cont.)

Drawable water volume

- Cylinder content heated to 60 °C
- Without reheating

Cylinder capacity	l	300	400	500	750 ^{*2}	950 ^{*2}
Draw-off rate	l/min	15	15	15	15	15
Drawable water volume	l	110	120	220	330	420

Water at t = 60 °C (constant)

Heat-up time

The specified heat-up times will be achieved when the maximum continuous output of the DHW cylinder is made available at the relevant heating water flow temperature and when DHW is heated from 10 to 60 °C.

Cylinder capacity	l	300	400	500	750 ^{*2}	950 ^{*2}
Heat-up time						
at heating water flow temperature						
90 °C	min	16	17	19	17	18
80 °C	min	22	23	24	21	22
70 °C	min	30	36	37	26	28

Pressure drop on the heating water side

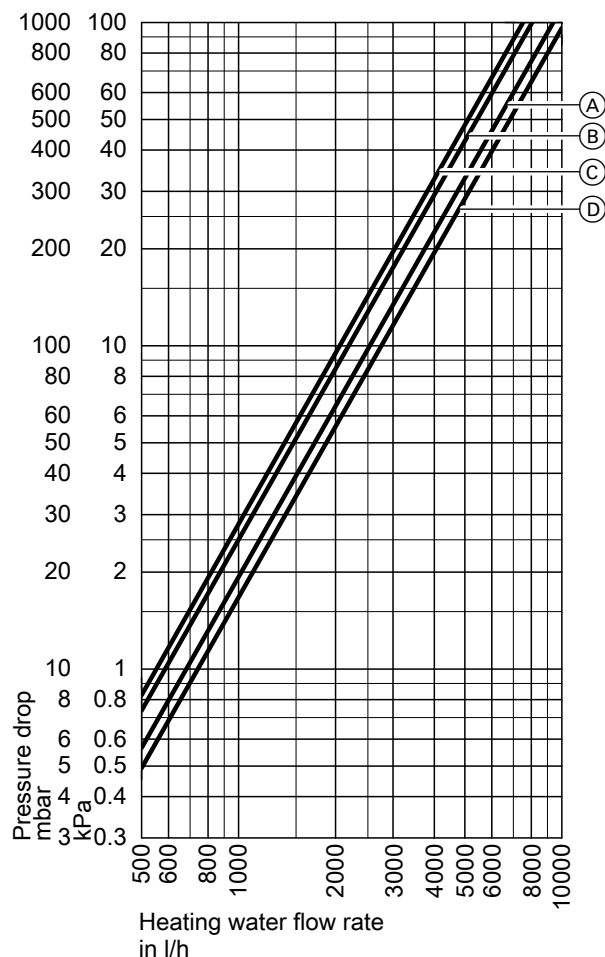

- (A) Cylinder capacity 300 l (upper indirect coil)
- (B) Cylinder capacity 300 l (lower indirect coil)
- (C) Cylinder capacity 500 l (lower indirect coil)
- (D) Cylinder capacity 400 l (lower indirect coil)

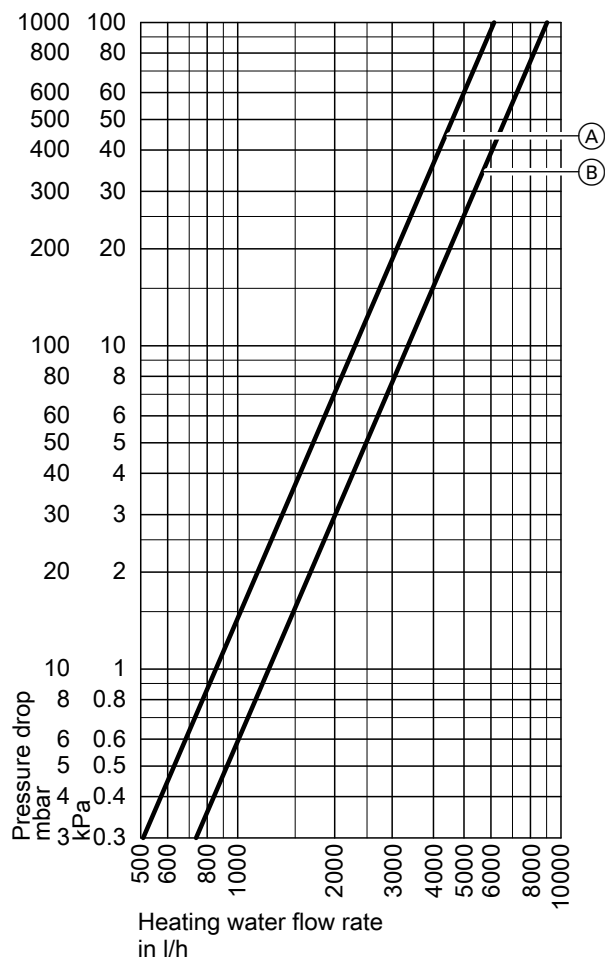

- (A) Cylinder capacity 750 and 950 l (upper indirect coil)
- (B) Cylinder capacity 750 and 950 l (lower indirect coil)

^{*2} Values determined by calculation.

DHW cylinders (cont.)

Pressure drop on the DHW side

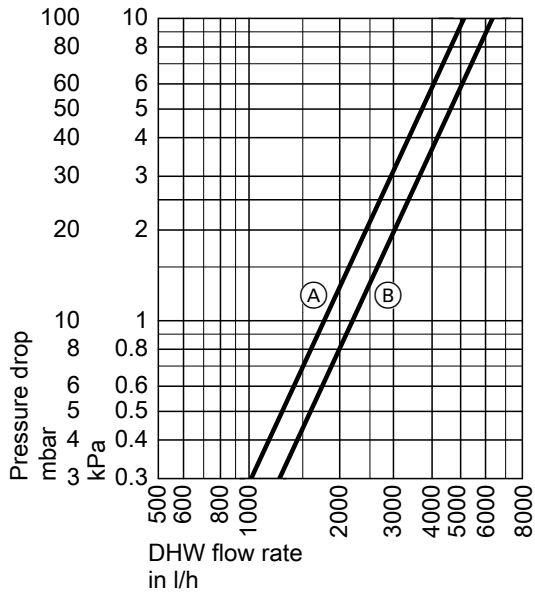

- (A) Cylinder capacity 300 l
- (B) Cylinder capacity 400 and 500 l

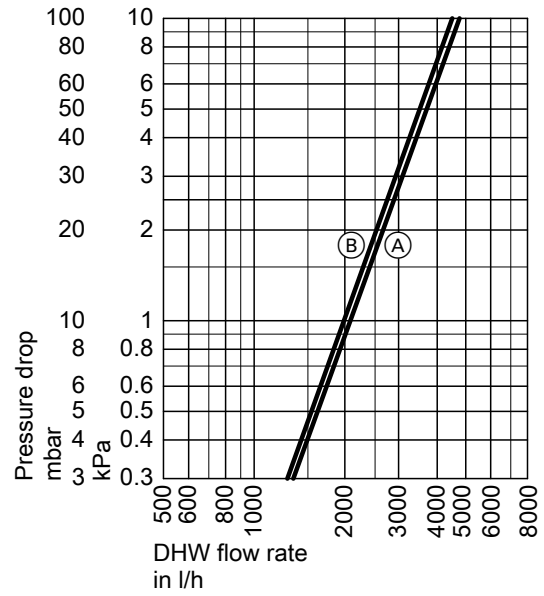

- (A) Cylinder capacity 750 l
- (B) Cylinder capacity 950 l

7.3 Vitocell 100-V, type CVWA

For DHW heating in conjunction with heat pumps up to 17 kW and solar collectors; also suitable for boilers and district heating systems

Suitable for the following systems:

- DHW temperature up to **95 °C**
- Heating water flow temperature up to **110 °C**
- Solar flow temperature up to **140 °C**

- Operating pressure on the **heating water side** up to **10 bar (1.0 MPa)**
- Operating pressure on the **solar side** up to **10 bar (1.0 MPa)**
- Operating pressure on the **DHW side** up to **10 bar (1.0 MPa)**

Vitocell 100-V, colour: Vitosilver

Vitocell 100-W, colour: White

Specification

Type		CVWA		
Cylinder capacity (AT: Actual water capacity)	I	300	390	500
Heating water capacity	I	22	27	40
Gross volume	I	322	417	540
DIN registration no.		9W173-13MC/E		
Continuous output for DHW heating from 10 to 45 °C and a heating water flow temperature of ... at the heating water flow rate stated below				
90 °C	kW	85	98	118
	l/h	2093	2422	2896
80 °C	kW	71	82	99
	l/h	1749	2027	2428
70 °C	kW	57	66	79
	l/h	1399	1623	1950
60 °C	kW	42	49	59
	l/h	1033	1202	1451
50 °C	kW	25	29	36
	l/h	617	723	881
Continuous output for DHW heating from 10 to 60°C and a heating water flow temperature of ... at the heating water flow rate stated below				
90 °C	kW	73	85	102
	l/h	1255	1458	1754
80 °C	kW	58	67	81
	l/h	995	1159	1399
70 °C	kW	41	48	59
	l/h	710	830	1008
Heating water flow rate for the stated continuous outputs	m ³ /h	3.0	3.0	3.0
Draw-off rate	l/min	15	15	15
Drawable water volume without reheating				
– Cylinder content heated to 45 °C Water at t = 45 °C (constant)	I	210	285	350
– Cylinder content heated to 55 °C Water at t = 55 °C (constant)	I	210	285	350
Heat-up time if connected to a heat pump with 16 kW rated heating output and a heating water flow temperature of 55 or 65 °C				
– For DHW heating from 10 to 45 °C	min	50	60	66
– For DHW heating from 10 to 55 °C	min	60	76	85
Max. connectable heat pump output at 65 °C heating water flow and 55 °C DHW temperature and the specified heating water flow rate	kW	12	15	17
Max. aperture area that can be connected to the solar heat exchanger set (accessories)				
– Vitosol-T	m ²	—	6	6
– Vitosol-F	m ²	—	11.5	11.5
Performance factor N_L in conjunction with a heat pump				
Cylinder storage temperature	45 °C	1.7	2.5	3.5
	50 °C	1.9	2.8	3.9
Standby heat loss	kWh/24 h	1.65	1.80	1.90
Dimensions				
Length (∅)				
– With thermal insulation	a	mm	667	859
– Excl. thermal insulation		mm	—	650
Total width				
– With thermal insulation	b	mm	744	923
– Excl. thermal insulation		mm	—	881
Height				
– With thermal insulation	c	mm	1734	1624
– Excl. thermal insulation		mm	—	1522
Height when tilted				
– Incl. thermal insulation		mm	1825	—
– Excl. thermal insulation		mm	—	1860



DHW cylinders (cont.)

Type		CVWA		
		300	390	500
Cylinder capacity (AT: Actual water capacity)	l			
Entire weight incl. thermal insulation	kg	180	190	200
Heating surface	m ²	3.0	4.0	5.5
Connections				
Heating water flow and return (male thread)	R	1¼	1¼	1¼
Cold water, DHW (male thread)	R	1	1	1
Solar heat exchanger set (male thread)	R	—	¾	¾
DHW circulation (male thread)	R	¾	¾	¾
Immersion heater (female thread)	Rp	1½	1½	1½
Energy efficiency class		B	B	B

Information regarding continuous output

When designing systems with the specified or calculated continuous output, select a matching circulation pump. The stated continuous output is achieved only if the rated boiler heating output is \geq continuous output.

Take the following into account when sizing entry points:

The actual dimensions of the DHW cylinder may vary slightly due to manufacturing tolerances.

DHW cylinders (cont.)

300 litre capacity

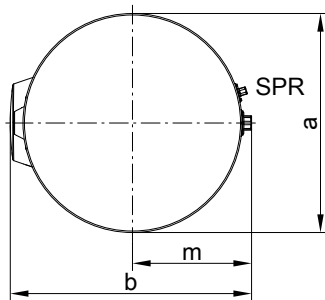
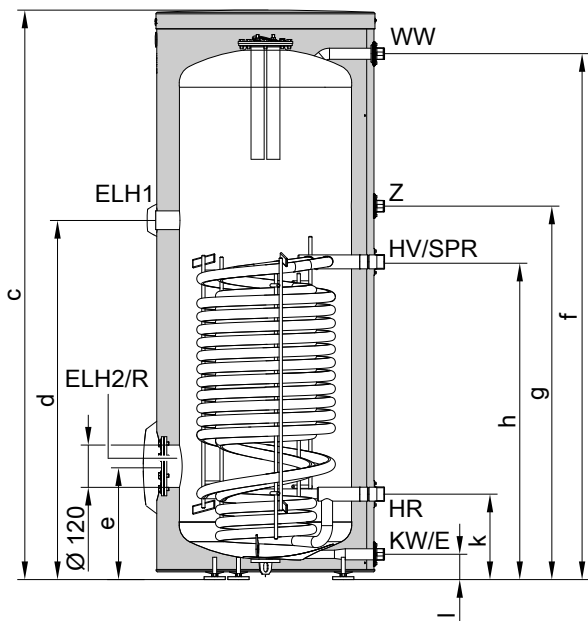

Dimensions

Cylinder capacity		I	300
Length (∅)	a	mm	667
Width	b	mm	744
Height	c	mm	1734
	d	mm	1063
	e	mm	314
	f	mm	1601
	g	mm	1137
	h	mm	967
	k	mm	261
	l	mm	77
	m	mm	360

- E Drain outlet
- ELH1 Connector for immersion heater
- ELH2 Flanged aperture for immersion heater
- HR Heating water return
- HV Heating water flow
- KW Cold water
- R Inspection and cleaning aperture with flange cover
- SPR Sensor well for cylinder temperature sensor or temperature controller (internal diameter 16 mm)
- WW DHW
- Z DHW circulation

DHW cylinders (cont.)

390 and 500 l capacity

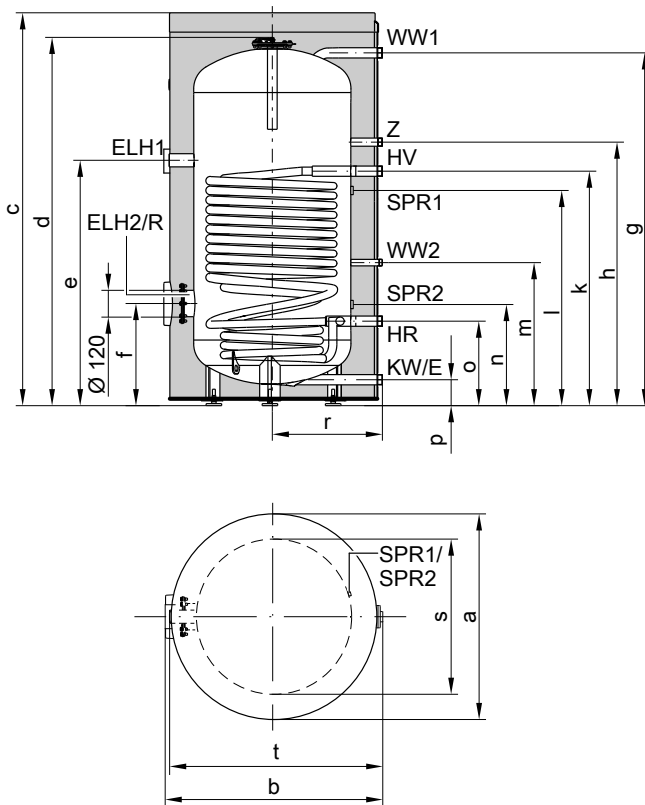

Dimensions

Cylinder capacity		l	390	500
Length (∅)	a	mm	859	859
Width	b	mm	923	923
Height	c	mm	1624	1948
	d	mm	1522	1844
	e	mm	1000	1307
	f	mm	403	442
	g	mm	1439	1765
	h	mm	1070	1370
	k	mm	950	1250
	l	mm	816	1116
	m	mm	572	572
	n	mm	366	396
	o	mm	330	330
	p	mm	88	88
	r	mm	455	455
	s	mm	650	650
	t	mm	881	881

Performance factor N_L

To DIN 4708

Cylinder storage temperature T_{cyl} = cold water inlet temperature + 50 K +5 K/-0 K

- E Drain outlet
- ELH1 Connector for immersion heater
- ELH2 Flanged aperture for immersion heater
- HR Heating water return
- HV Heating water flow
- KW Cold water
- R Inspection and cleaning aperture with flange cover
- SPR1 Clamping device for securing immersion temperature sensors to the cylinder jacket. Fixing point for 3 immersion temperature sensors per clamping device
- SPR2 Clamping device for securing immersion temperature sensors to the cylinder jacket. Fixing point for 3 immersion temperature sensors per clamping device
- WW1 DHW
- WW2 DHW from solar heat exchanger set
- Z DHW circulation

Cylinder capacity	l	300	390	500
Performance factor N_L				
at heating water flow temperature				
90 °C		9.5	12.6	16.5
80 °C		8.5	11.3	14.9
70 °C		7.5	10.0	13.3

DHW cylinders (cont.)

Information on performance factor N_L

The performance factor N_L depends on the cylinder storage temperature T_{cyl} .

Standard values

- $T_{cyl} = 60\text{ °C} \rightarrow 1.0 \times N_L$
- $T_{cyl} = 55\text{ °C} \rightarrow 0.75 \times N_L$
- $T_{cyl} = 50\text{ °C} \rightarrow 0.55 \times N_L$
- $T_{cyl} = 45\text{ °C} \rightarrow 0.3 \times N_L$

Peak output (over 10 minutes)

Relative to performance factor N_L
DHW heating from 10 to 45 °C

Cylinder capacity	l	300	390	500
Peak output				
at heating water flow temperature				
90 °C	l/10 min	415	540	690
80 °C	l/10 min	400	521	667
70 °C	l/10 min	357	455	596

Max. draw-off rate (over 10 minutes)

Relative to performance factor N_L

With reheating

DHW heating from 10 to 45 °C

Cylinder capacity	l	300	390	500
Max. draw-off rate				
at heating water flow temperature				
90 °C	l/min	41	54	69
80 °C	l/min	40	52	66
70 °C	l/min	35	46	59

DHW cylinders (cont.)

Pressure drop on the heating water side

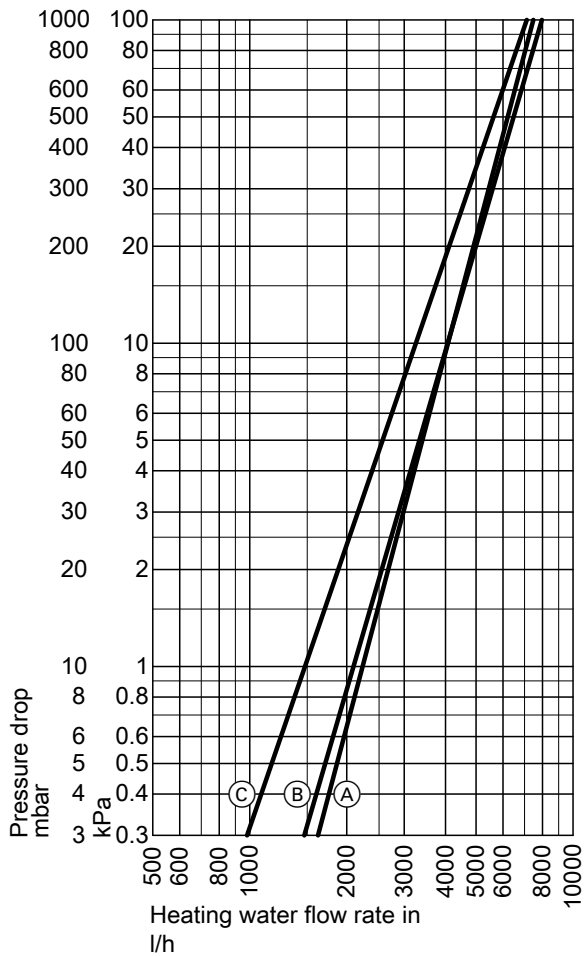

- (A) Cylinder capacity 300 l
- (B) Cylinder capacity 390 l
- (C) Cylinder capacity 500 l

Pressure drop on the DHW side

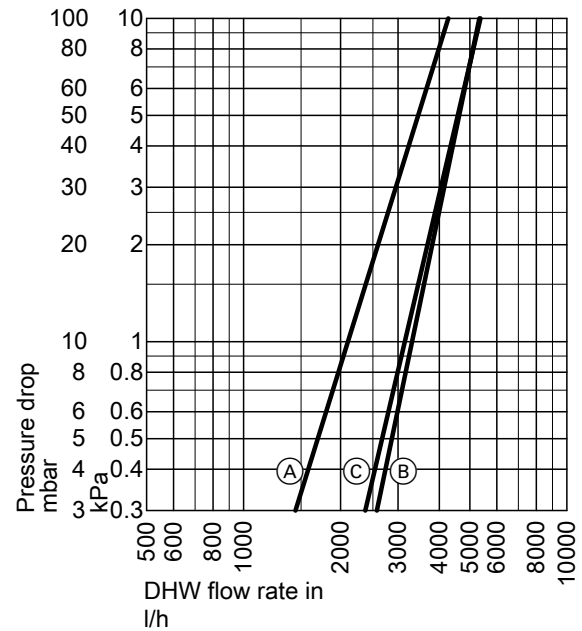

- (A) Cylinder capacity 300 l
- (B) Cylinder capacity 390 l
- (C) Cylinder capacity 500 l

Solar heat exchanger set

Part no. 7186663

For the connection of solar collectors to the Vitocell 100-V/100-W, type CVWA (390 and 500 l capacity)
Suitable for systems to DIN 4753. Total water hardness of up to 20 °dH (3.6 mol/m³)

Max. collector surface area that can be connected:

- 11.5 m² flat-plate collectors
- 6 m² tube collectors

Specification

Permissible temperatures	
Solar side	140 °C
Heating water side	110 °C
DHW side	
– For boiler operation	95 °C
– For solar operation	60 °C
Permissible operating pressure	
Solar side, heating and DHW side	10 bar (1.0 MPa)
Test pressure	
Solar side, heating and DHW side	13 bar (1.3 MPa)
Minimum wall clearance	
For installation of the solar heat exchanger set	350 mm
Circulation pump	
Power supply	230 V/50 Hz
IP rating	IP 42

DHW cylinders (cont.)

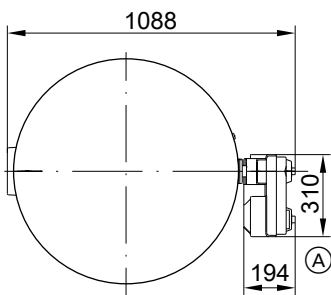
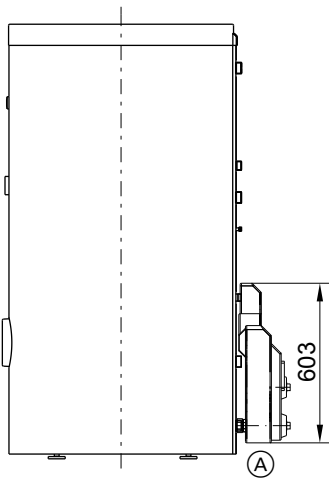

Ⓐ Solar heat exchanger set

DHW cylinders (cont.)

7.4 Vitocell 300-B, type EVBA-A

For DHW heating in conjunction with boilers and solar collectors for dual mode operation.

Suitable for the following systems:

- DHW temperature up to **95 °C**
- Heating water flow temperature up to **160 °C**
- Solar flow temperature up to **160 °C**

- Operating pressure **on the heating water side** up to **10 bar (1 MPa)**

- Operating pressure **on the solar side** up to **10 bar (1 MPa)**
- Operating pressure **on the DHW side** up to **10 bar (1 MPa)**

Vitocell 300-B, colour: Vitosilver

Type	EVBA-A		EVBA-A			
Cylinder capacity (AT: Actual water capacity)	I	300		500		
Heating water capacity						
– Upper indirect coil	I	6.7		10.0		
– Lower indirect coil	I	11.0		12.9		
Gross volume	I	317.7		522.9		
DIN registration number		Applied for				
Internal indirect coil		upper	lower	upper	lower	
Continuous output For DHW heating from 10 to 45 °C and a heating water flow temperature of ... at the heating water flow rate stated below	90 °C	kW l/h	43 1058	61 1501	57 1409	69 1688
	80 °C	kW l/h	35 861	51 1252	48 1175	59 1414
	70 °C	kW l/h	28 701	41 998	38 936	46 1128
	60 °C	kW l/h	20 513	30 733	28 687	34 830
	50 °C	kW l/h	12 302	18 434	16 406	20 491
Continuous output For DHW heating from 10 to 60 °C and a heating water flow temperature of ... at the heating water flow rate stated below	90 °C	kW l/h	36 627	52 894	49 838	59 1011
	80 °C	kW l/h	29 494	41 706	38 662	46 799
	70 °C	kW l/h	20 349	29 501	27 469	33 568
Heating water flow rate for the stated continuous outputs		m ³ /h	3.0	3.0	3.0	3.0
Max. connectable heat pump output At a heating water flow temperature of 55 °C and a DHW temperature of 45 °C For the specified heating water flow rate (both indirect coils connected in series)		kW		8.0		10.0
Standby heat loss		kWh/24 h		1.06		1.37
Standby capacity V_{aux}	I			139		235
Solar capacity V_{sol}	I			161		265
Dimensions						
Length a (Ø)	– Incl. thermal insulation	mm		667		1022
	– Excl. thermal insulation	mm		–		715
Width b	– Incl. thermal insulation	mm		744		1084
	– Excl. thermal insulation	mm		–		954
Height c	– Incl. thermal insulation	mm		1734		1852
	– Excl. thermal insulation	mm		–		1667
Height when tilted	– Incl. thermal insulation	mm		1825		–
	– Excl. thermal insulation	mm		–		1690
Weight incl. thermal insulation		kg		113		123
Heating surface		m ²	0.9	1.5	1.3	1.7
Connections (male thread)						
Indirect coils	R			1		1
Cold water, DHW	R			1		1¼
DHW circulation	R			1		1
Energy efficiency class			A		A	

Information regarding the upper indirect coil

The upper indirect coil is designed for connection to a heat generator.

Information regarding the lower indirect coil

The lower indirect coil is designed for connection to solar collectors. To install the cylinder temperature sensor, use the threaded elbow with sensor well included in standard delivery.

DHW cylinders (cont.)

Information regarding continuous output

When designing systems with the specified or calculated continuous output, select a matching circulation pump. The stated continuous output is achieved only if rated boiler heating output \geq continuous output.

Take the following into account when sizing entry points:

The actual dimensions of the DHW cylinder may vary slightly due to manufacturing tolerances.

300 l capacity

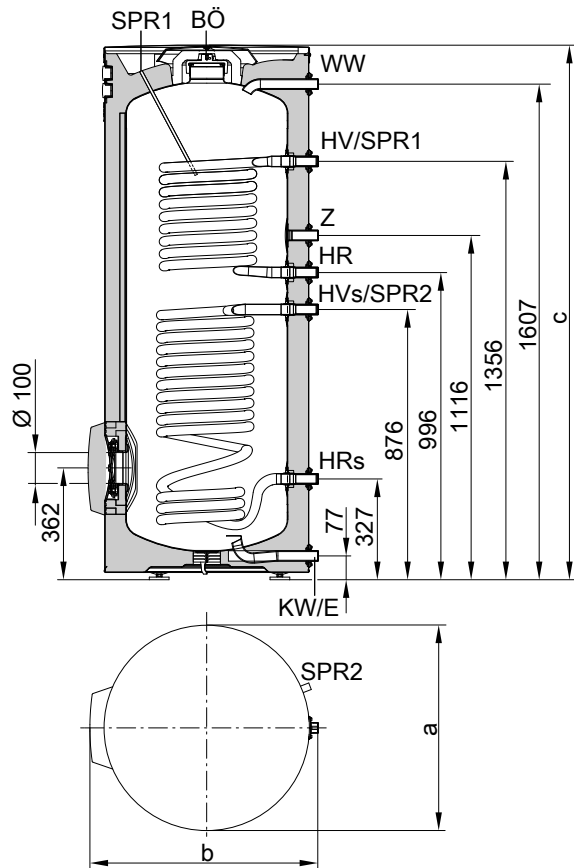

BÖ	Inspection and cleaning aperture
E	Drain
HR	Heating water return
HR _s	Heating water return, solar thermal system
HV	Heating water flow
HV _s	Heating water flow, solar thermal system
KW	Cold water
SPR1	Sensor well for cylinder temperature sensor of cylinder temperature controller (internal diameter 7 mm)
SPR2	Sensor well for cylinder temperature sensor/thermometer sensor (internal diameter 17 mm)
WW	DHW
Z	DHW circulation

500 l capacity

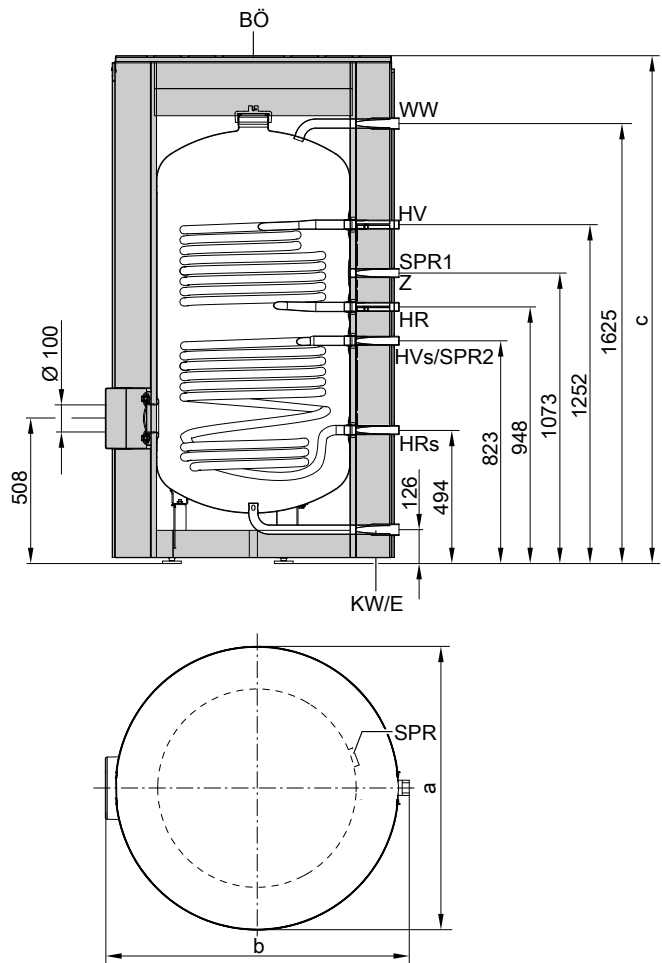

BÖ	Inspection and cleaning aperture
E	Drain
HR	Heating water return
HR _s	Heating water return, solar thermal system
HV	Heating water flow
HV _s	Heating water flow, solar thermal system
KW	Cold water
SPR1	Cylinder temperature controller cylinder temperature sensor (clamping system for fixing immersion temperature sensors to the cylinder jacket)
SPR2	Temperature sensors/thermometer sensors (clamping system for securing immersion temperature sensors to the cylinder jacket)
WW	DHW
Z	DHW circulation

DHW cylinders (cont.)

Cylinder temperature sensor for solar operation

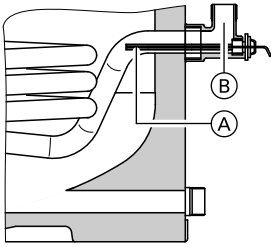

- Ⓐ Cylinder temperature sensor (standard delivery of solar control unit)
- Ⓑ Threaded elbow with sensor well (standard delivery)

Arrangement of cylinder temperature sensor in the heating water return HR_s

Performance factor N_L

To DIN 4708 – upper indirect coil.

Cylinder storage temperature $T_{cyl} = \text{cold water inlet temperature} + 50 \text{ K} \text{ }^{+5 \text{ K}/-0 \text{ K}}$

Cylinder capacity	I	300	500
Performance factor N_L at heating water flow temperature			
90 °C		2.4	7.0
80 °C		2.2	6.5
70 °C		2.0	6.0

Information regarding performance factor N_L

The performance factor N_L depends on the cylinder storage temperature T_{cyl} .

Standard values

- $T_{cyl} = 60 \text{ °C} \rightarrow 1.0 \times N_L$
- $T_{cyl} = 55 \text{ °C} \rightarrow 0.75 \times N_L$
- $T_{cyl} = 50 \text{ °C} \rightarrow 0.55 \times N_L$
- $T_{cyl} = 45 \text{ °C} \rightarrow 0.3 \times N_L$

Peak output (over 10 minutes)

Relative to the performance factor N_L .

DHW heating from 10 to 45 °C.

Cylinder capacity	I	300	500
Peak output (l/10 min) at heating water flow temperature			
90 °C		211	404
80 °C		203	333
70 °C		195	319

Max. draw-off rate (over 10 minutes)

Relative to the performance factor N_L .

With reheating.

DHW heating from 10 to 45 °C.

Cylinder capacity	I	300	500
Max. draw-off rate (l/min) at heating water flow temperature			
90 °C		21.1	40.4
80 °C		20.3	33.3
70 °C		19.5	31.9

DHW cylinders (cont.)

Pressure drops

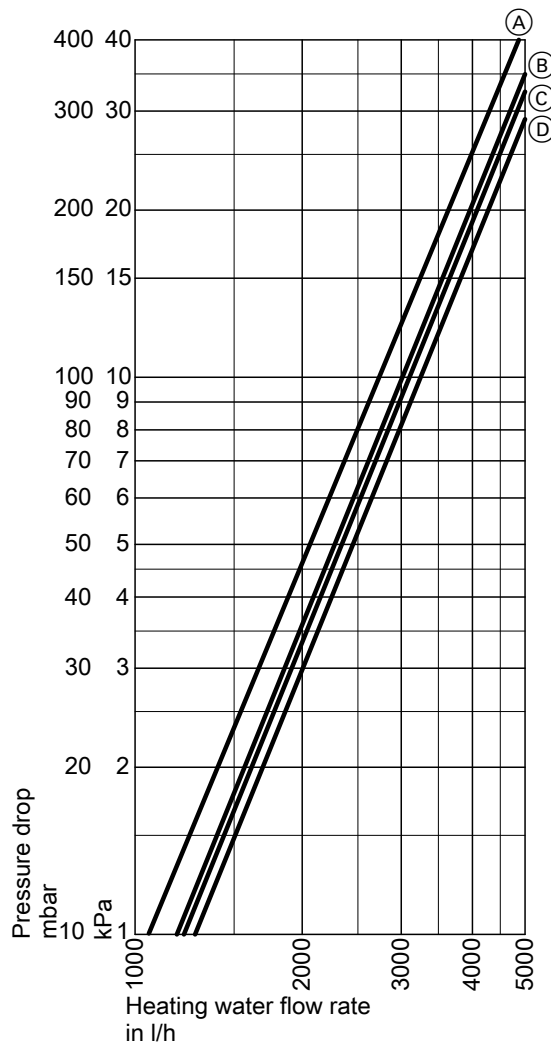

Pressure drop on the heating water side

- (A) Cylinder capacity 300 l (lower indirect coil)
- (B) Cylinder capacity 300 l (upper indirect coil)
- (C) Cylinder capacity 500 l (lower indirect coil)
- (D) Cylinder capacity 500 l (upper indirect coil)

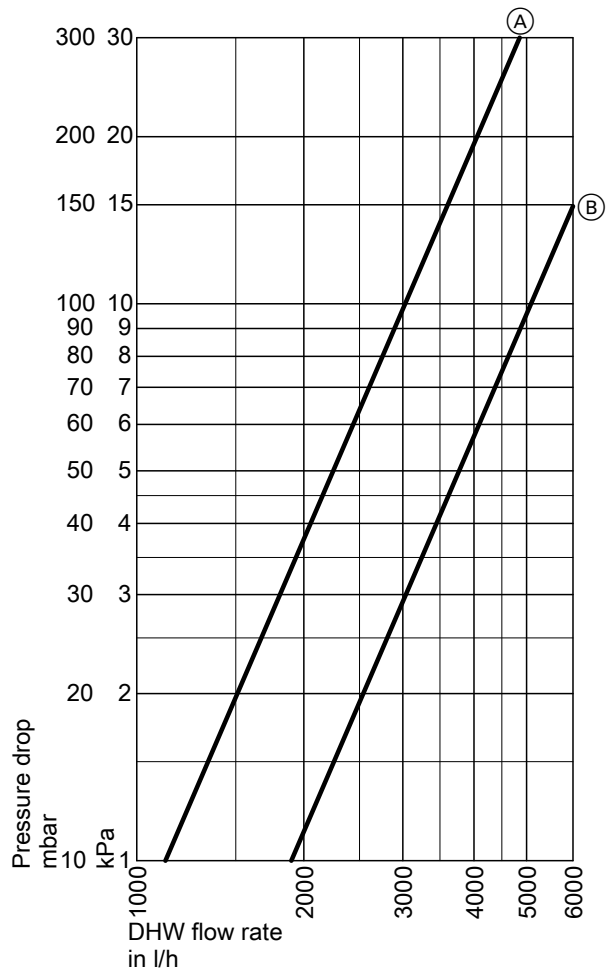

Pressure drop on the DHW side

- (A) Cylinder capacity 300 l
- (B) Cylinder capacity 500 l

7.5 Vitocell 140-E, type SEIA/SEIC and Vitocell 160-E, type SESB

- Vitotrans for hygienic DHW heating in accordance with the instantaneous water heater principle available as an accessory. See page 126.
- Connection set with Solar-Divicon for mounting on the Vitocell, available as an accessory (included in standard delivery for Vitocell 140-E, 400 l). See page 89.

For storing heating water in conjunction with solar collectors, heat pumps and solid fuel boilers Vitocell 140-E/160-E, colour: Vitosilver

Suitable for the following systems:

- Heating water flow temperature up to **110 °C**
- Solar flow temperature up to **140 °C**
- Operating pressure **on the heating water side** up to **3 bar (0.3 MPa)**
- Operating pressure **on the solar side** up to **10 bar (1.0 MPa)**

Specification

Type	Vitocell 140-E				Vitocell 160-E	
	SEIA	SEIC	SEIC	SEIC	SESB	SESB
Cylinder capacity (AT: Actual water content)	400	600	750	950	750	950
Solar indirect coil capacity	10.5	12	12	14	12	14
Heating water capacity	389.5	588	738	936	738	936
DIN registration number	0264/07E				0265/07E	
Dimensions						
Length (∅)						
– Incl. thermal insulation	a	mm	859	1064	1064	1064
– Excl. thermal insulation		mm	650	790	790	790
Width						
– Incl. thermal insulation	b	mm	1089	1119	1119	1119
– Excl. thermal insulation		mm	863	1042	1042	1042
Height						
– Incl. thermal insulation	c	mm	1617	1645	1900	2200
– Excl. thermal insulation		mm	1506	1520	1814	2120
Height when tilted						
– Excl. thermal insulation and adjustable feet		mm	1550	1630	1890	2195
Weight						
– Incl. thermal insulation		kg	154	135	159	182
– Excl. thermal insulation		kg	137	112	131	150
Connections (male thread)						
Heating water flow and return	R		1¼	2	2	2
Heating water flow and return (solar)	G		1	1	1	1
Solar indirect coil						
Heating surface		m ²	1.5	1.8	1.8	2.1
Standby heat loss		kWh/24 h	1.80	2.10	2.25	2.45
Standby capacity V_{aux}		l	210	230	380	453
Solar capacity V_{sol}		l	190	370	370	497
Energy efficiency class			B	—	—	—

Take the following into account when sizing entry points:

The actual dimensions of the DHW cylinder may vary slightly due to manufacturing tolerances.

DHW cylinders (cont.)

Vitocell 140-E, type SEIA, 400 l

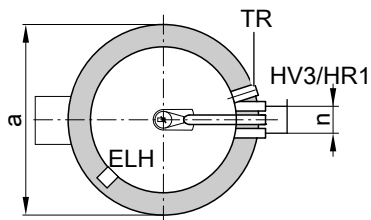
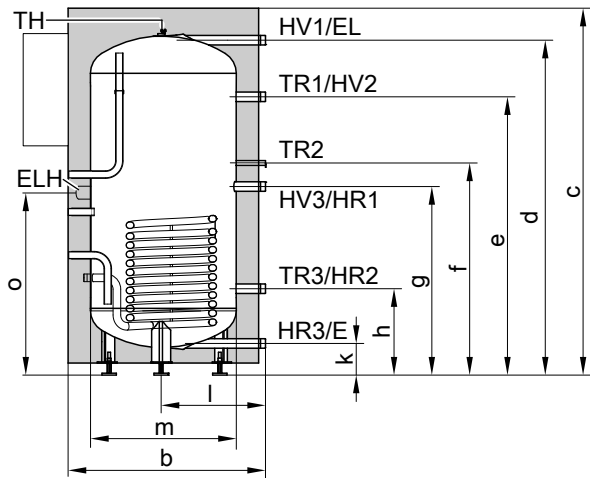

Dimensions

Cylinder capacity		l	400
Length (∅)	a	mm	859
Width			
– Without Solar-Divicon	b	mm	898
– With Solar-Divicon	b	mm	1089
Height	c	mm	1617
	d	mm	1458
	e	mm	1206
	f	mm	911
	g	mm	806
	h	mm	351
	k	mm	107
	l	mm	455
∅ excl. thermal insulation	m	mm	∅ 650
	n	mm	120
	o	mm	785

- E Drain
- EL Air vent valve
- HR Heating water return
- HV Heating water flow
- TH Retainer for thermometer sensor or additional sensor (clamping bracket)
- TR Sensor well for cylinder temperature sensor/temperature controller (internal diameter 16 mm)
- ELH Female connection for immersion heater EHE (Rp 1½)

DHW cylinders (cont.)

Vitocell 140-E, type SEIC, 600, 750 and 950 l

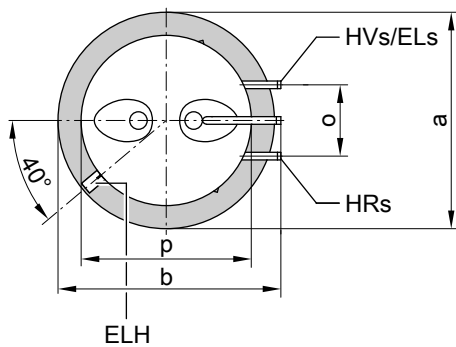
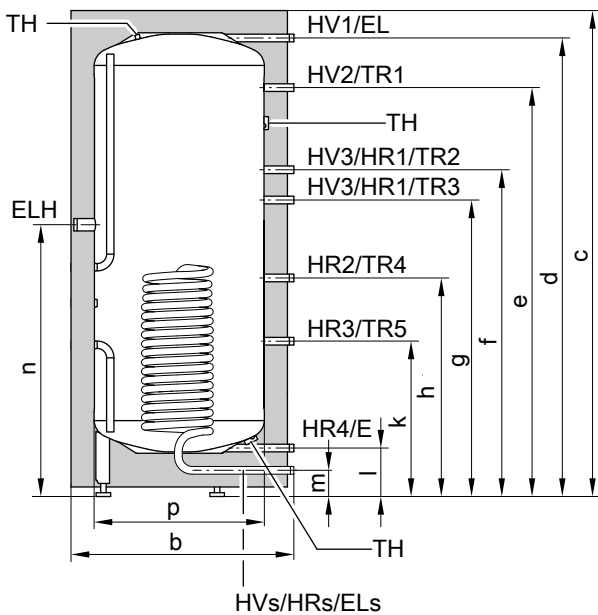

Dimensions

Cylinder capacity	l	600	750	950
Length (∅)	a mm	1064	1064	1064
Width	b mm	1119	1119	1119
Height	c mm	1645	1900	2200
	d mm	1497	1777	2083
	e mm	1296	1559	1864
	f mm	926	1180	1300
	g mm	785	1039	1159
	h mm	598	676	752
	k mm	355	386	386
	l mm	155	155	155
	m mm	75	75	75
	n mm	910	1010	1033
	o mm	370	370	370
Length (∅) excl. thermal insulation	p mm	790	790	790

- E Drain
- EL Air vent valve
- EL_s Solar indirect coil, air vent valve
- ELH Female connection for immersion heater EHE (Rp 1½)
- HR Heating water return
- HR_s Heating water return, solar thermal system
- HV Heating water flow
- HV_s Heating water flow, solar thermal system
- TH Retainer for thermometer sensor or additional sensor (clamping bracket)
- TR Clamping system for securing immersion temperature sensors to the cylinder jacket. Retainers for 3 immersion temperature sensors per clamping system

DHW cylinders (cont.)

Vitocell 160-E, type SESB, 750 and 950 l

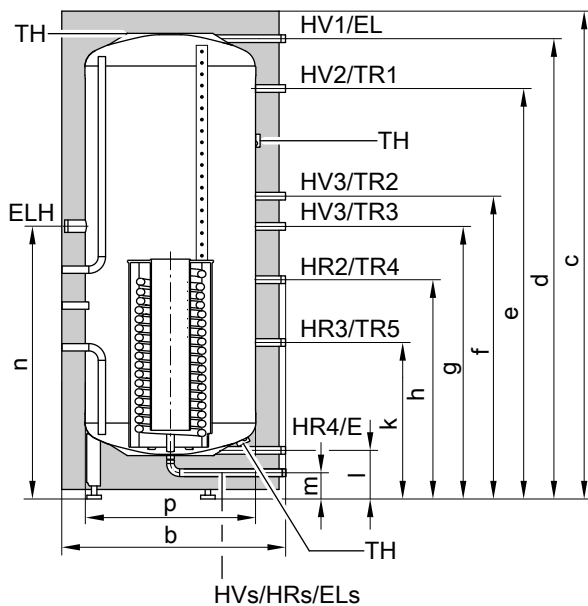

Dimensions

Cylinder capacity		l	750	950
Length (∅)	a	mm	1064	1064
Width	b	mm	1119	1119
Height	c	mm	1900	2200
	d	mm	1777	2083
	e	mm	1559	1864
	f	mm	1180	1300
	g	mm	1039	1159
	h	mm	676	752
	k	mm	386	386
	l	mm	155	155
	m	mm	75	75
	n	mm	1010	1033
	o	mm	370	370
Length (∅) excl. thermal insulation	p	mm	790	790

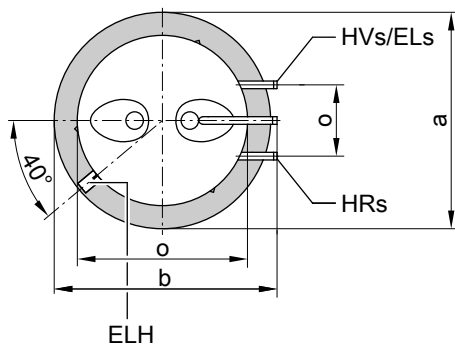

- E Drain
- EL Air vent valve
- EL_s Solar indirect coil, air vent valve
- ELH Female connection for immersion heater EHE (Rp 1½)
- HR Heating water return
- HR_s Heating water return, solar thermal system
- HV Heating water flow
- HV_s Heating water flow, solar thermal system
- TH Retainer for thermometer sensor or additional sensor (clamping bracket)
- TR Clamping system for securing immersion temperature sensors to the cylinder jacket. Retainers for 3 immersion temperature sensors per clamping system

DHW cylinders (cont.)

Pressure drops

Pressure drop on the heating water side

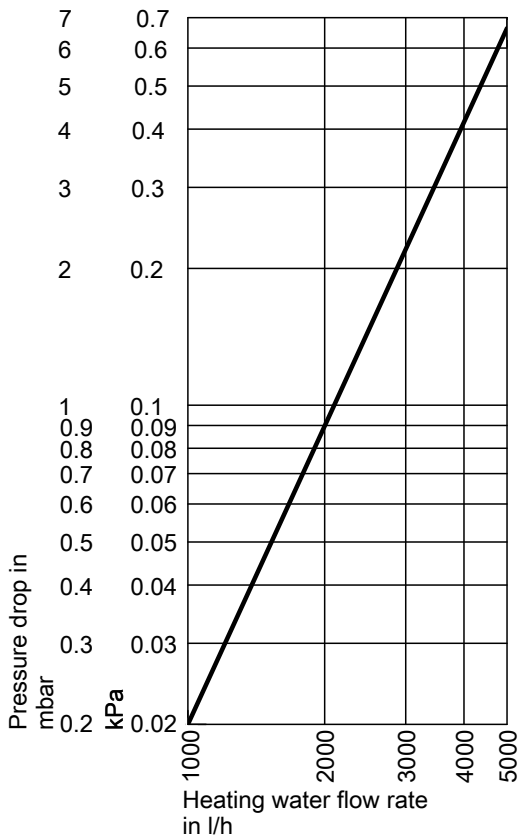

Solar side pressure drop

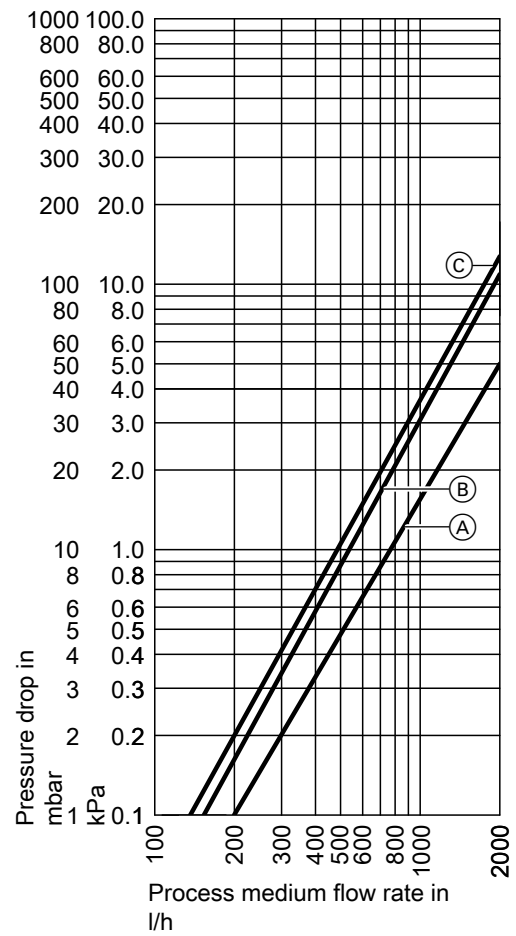

- (A) Cylinder capacity 400 l
- (B) Cylinder capacity 600 and 750 l
- (C) Cylinder capacity 950 l

7.6 Vitocell 340-M, type SVKC and Vitocell 360-M, type SVSB

For storing heating water and providing DHW heating in conjunction with solar collectors, heat pumps and solid fuel boilers

- Operating pressure on the solar side up to 10 bar (1.0 MPa)
- Operating pressure on the DHW side up to 10 bar (1.0 MPa)
- Total water hardness of up to 20 °dH (3.6 mol/m³)

Suitable for the following systems:

- DHW temperature up to 95 °C
- Heating water flow temperature up to 110 °C
- Solar flow temperature up to 140 °C
- Operating pressure on the heating water side up to 3 bar (0.3 MPa)

Vitocell 340-M, colour: Vitosilver

Vitocell 360-M, colour: Vitosilver

Specification

Type		SVKC/SVSB	SVKC/SVSB
Cylinder capacity (AT: Actual water capacity)	l	750	950
Solar indirect coil capacity	l	12	14
DHW indirect coil capacity	l	30	30
Heating water capacity	l	708	906
DIN registration number			
– Vitocell 340-M		9W262-10MC/E	
– Vitocell 360-M		9W263-10MC/E	
Dimensions			
Length (∅)			
– Incl. thermal insulation	a mm	1064	1064
– Excl. thermal insulation	mm	790	790
Width	b mm	1119	1119
Height			
– Incl. thermal insulation	c mm	1900	2200
– Excl. thermal insulation	mm	1815	2120
Height when tilted			
– Excl. thermal insulation and adjustable feet	mm	1890	2165
Weight of Vitocell 340-M			
– Incl. thermal insulation	kg	199	222
– Excl. thermal insulation	kg	171	199
Weight of Vitocell 360-M			
– Incl. thermal insulation	kg	208	231
– Excl. thermal insulation	kg	180	208
Connections (male thread)			
Heating water flow and return	R	1¼	1¼
Cold water, DHW	R	1	1
Heating water flow and return (solar)	G	1	1
Drain	R	1¼	1¼
Solar indirect coil			
Heating surface	m ²	1.8	2.1
DHW indirect coil			
Heating surface	m ²	6.7	6.7
Standby heat loss	kWh/24 h	2.25	2.45
Standby capacity V_{aux}	l	346	435
Solar capacity V_{sol}	l	404	515
Energy efficiency class		—	—

Take the following into account when sizing entry points:

The actual dimensions of the DHW cylinder may vary slightly due to manufacturing tolerances.

DHW cylinders (cont.)

Vitocell 340-M, type SVKC

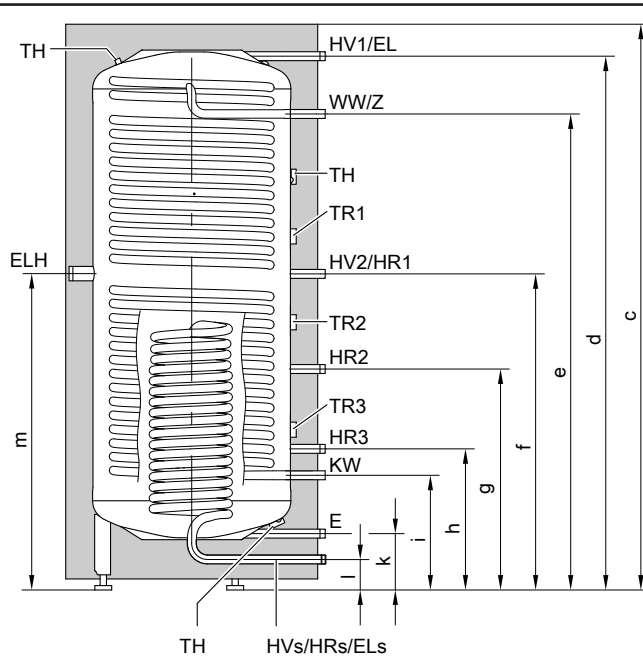

Dimensions

Cylinder capacity			750	950
Length (∅)	a	mm	1064	1064
Width	b	mm	1119	1119
Height	c	mm	1900	2200
	d	mm	1787	2093
	e	mm	1558	1863
	f	mm	1038	1158
	g	mm	850	850
	h	mm	483	483
	i	mm	383	383
	k	mm	145	145
	l	mm	75	75
	m	mm	1009	1135
	n	mm	185	185
Length excl. thermal insulation	o	mm	790	790

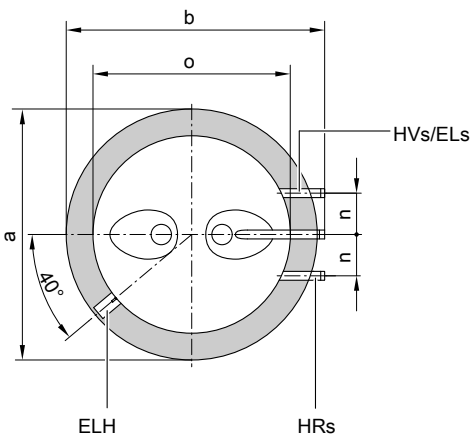

- E Drain outlet
- EL Air vent valve
- EL_s Solar indirect coil, air vent valve
- ELH Immersion heater (female connection Rp 1½)
- HR Heating water return
- HR_s Heating water return, solar thermal system
- HV Heating water flow
- HV_s Heating water flow, solar thermal system
- KW Cold water
- TH Retainer for thermometer sensor or additional sensor (clamping bracket)
- TR Clamping system for fixing immersion temperature sensors to the cylinder jacket. Retainers for 3 immersion temperature sensors per clamping system.
- WW DHW
- Z DHW circulation (threaded DHW circulation fitting, accessories)

DHW cylinders (cont.)

Vitocell 360-M, type SVSB

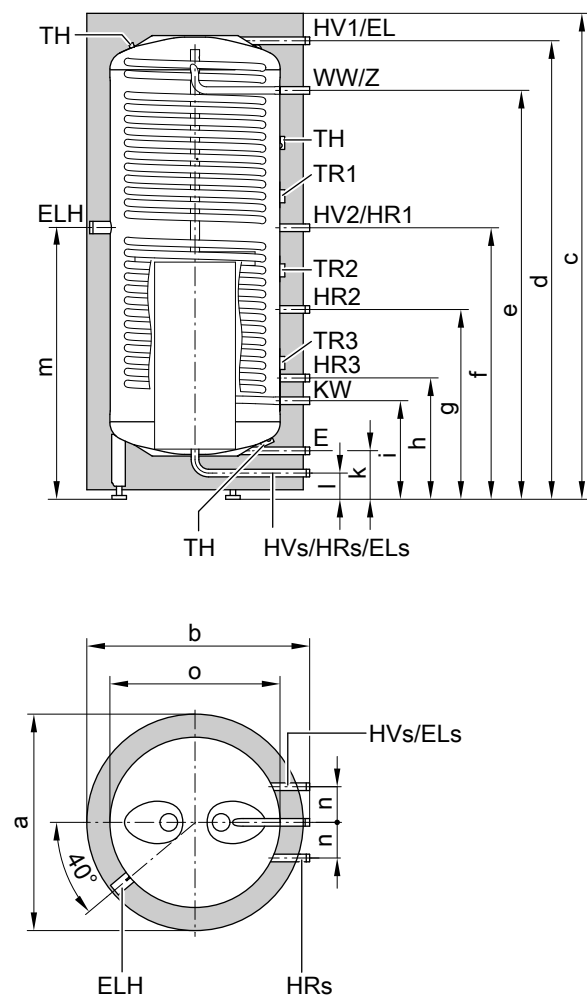

Dimensions

Cylinder capacity		750	950
Length (∅)	a mm	1064	1064
Width	b mm	1119	1119
Height	c mm	1900	2200
	d mm	1787	2093
	e mm	1558	1863
	f mm	1038	1158
	g mm	850	850
	h mm	483	483
	i mm	383	383
	k mm	145	145
	l mm	75	75
	m mm	1009	1135
	n mm	185	185
Length excl. thermal insulation	o mm	790	790

- E Drain outlet
- EL Air vent valve
- EL_s Solar indirect coil, air vent valve
- ELH Immersion heater (female connection Rp 1½)
- HR Heating water return
- HR_s Heating water return, solar thermal system
- HV Heating water flow
- HV_s Heating water flow, solar thermal system
- KW Cold water
- TH Retainer for thermometer sensor or additional sensor (clamping bracket)
- TR Clamping system for fixing immersion temperature sensors to the cylinder jacket. Retainers for 3 immersion temperature sensors per clamping system.
- WW DHW
- Z DHW circulation (threaded DHW circulation fitting, accessories)

Continuous output

- For a heating water flow temperature of 70 °C

Continuous output	kW	15	22	33
For DHW heating from 10 to 45 °C	l/h	368	540	810
– for heating water flow rate (measured via HV ₁ /HR ₁)	l/h	252	378	610
For DHW heating from 10 to 60 °C	l/h	258	378	567
– for heating water flow rate (measured via HV ₁ /HR ₁)	l/h	281	457	836

5822440

DHW cylinders (cont.)

Information regarding continuous output

When engineering systems with the specified or calculated continuous output, factor in a matching circulation pump. The stated continuous output is achieved only if rated boiler heating output is \geq continuous output.

Performance factor N_L

- To DIN 4708
- Subject to the heating output delivered by the boiler (Q_D)
- Cylinder storage temperature T_{cyl} = cold water inlet temperature + 50 K ^{+5 K/-0 K}
- 70 °C heating water flow temperature

Cylinder capacity	I	750	950
Performance factor N_L			
for Q_D			
15 kW		2.00	3.00
18 kW		2.25	3.20
22 kW		2.50	3.50
27 kW		2.75	4.00
33 kW		3.00	4.60

Information regarding performance factor

The performance factor N_L depends on the cylinder storage temperature T_{cyl} .

Standard values

- $T_{cyl} = 60\text{ °C} \rightarrow 1.0 \times N_L$
- $T_{cyl} = 55\text{ °C} \rightarrow 0.75 \times N_L$
- $T_{cyl} = 50\text{ °C} \rightarrow 0.55 \times N_L$
- $T_{cyl} = 45\text{ °C} \rightarrow 0.3 \times N_L$

Peak output (over 10 minutes)

- Relative to performance factor N_L
- Subject to the heating output delivered by the boiler (Q_D)
- DHW heating from 10 to 45 °C
- 70 °C heating water flow temperature

Cylinder capacity	I	750	950
Peak output			
for Q_D			
15 kW	l/10 min	190	230
18 kW	l/10 min	200	236
22 kW	l/10 min	210	246
27 kW	l/10 min	220	262
33 kW	l/10 min	230	280

Max. draw-off rate (over 10 minutes)

- Relative to performance factor N_L
- Subject to the heating output delivered by the boiler (Q_D)
- With reheating
- DHW heating from 10 to 45 °C
- 70 °C heating water flow temperature

Cylinder capacity	I	750	950
Max. draw-off rate			
for Q_D			
15 kW	l/min	19.0	23.0
18 kW	l/min	20.0	23.6
22 kW	l/min	21.0	24.6
27 kW	l/min	22.0	26.2
33 kW	l/min	23.0	28.0

Drawable water volume

- Cylinder content heated to 60 °C
- Without reheating

Draw-off rate	l/min	10	20
Drawable water volume			
Water with $t = 45\text{ °C}$ (mixed temperature)			
750 l	l	255	190
950 l	l	331	249

DHW cylinders (cont.)

Pressure drop on the heating water side

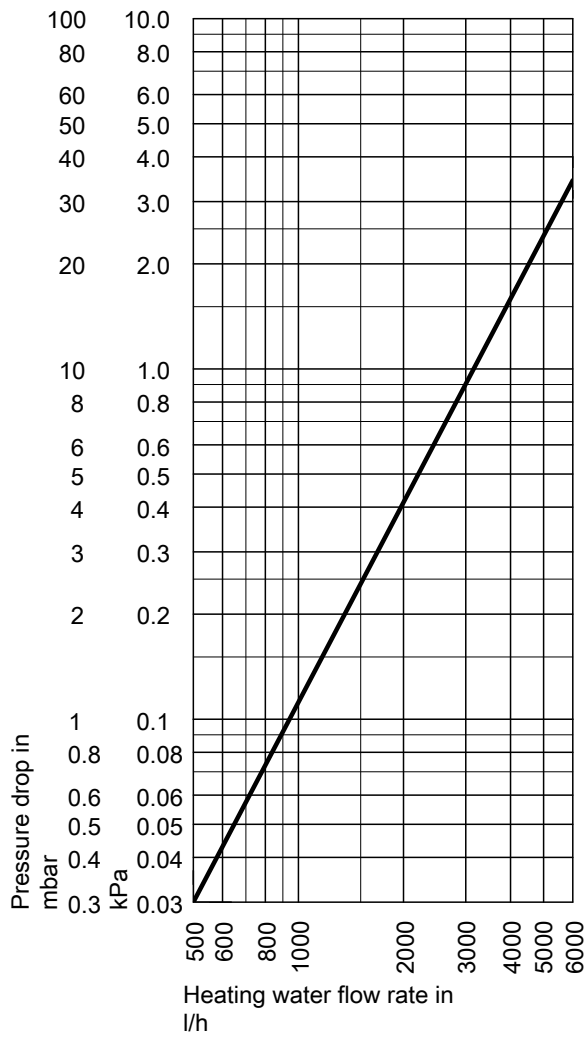

Solar side pressure drop

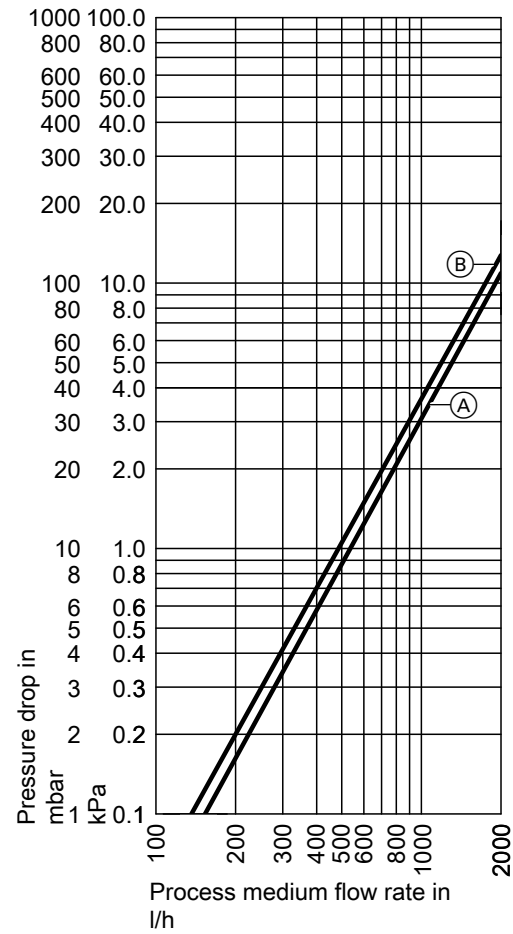

- (A) Cylinder capacity 750 l
- (B) Cylinder capacity 950 l

DHW cylinders (cont.)

Pressure drop on the DHW side

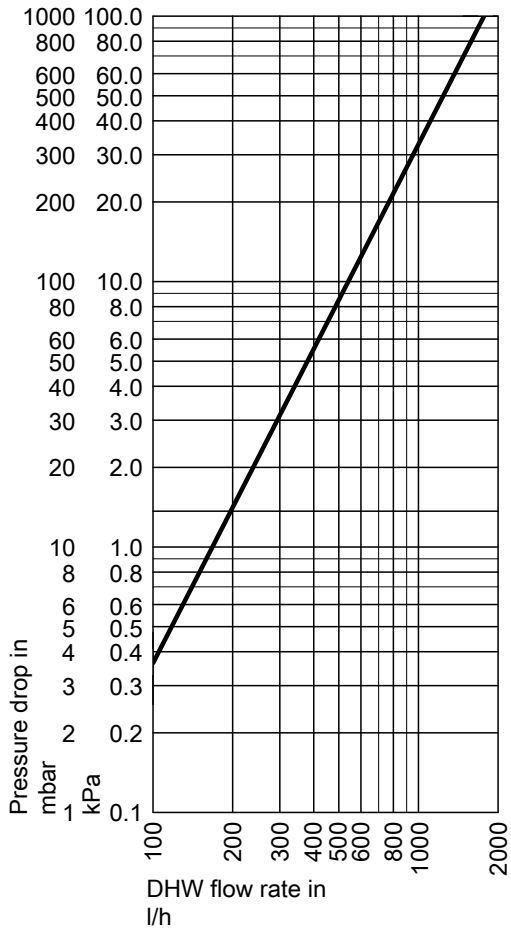

7.7 Vitocell 100-V, type CVA/CVAA/CVBA-A

For DHW heating in conjunction with boilers and district heating systems; optionally with an electric heater as an accessory for DHW cylinders with 300 and 500 l capacity

- Operating pressure on the heating water side up to 25 bar (2.5 MPa)
- Operating pressure on the DHW side up to 10 bar (1.0 MPa)

Suitable for the following systems:

- DHW temperature up to 95 °C
- Heating water flow temperature up to 160 °C

Vitocell 100-W, colour: Vitopearlwhite (160/200 l)

Vitocell 100-W, colour: White (300 l)

Vitocell 100-V, colour: Vitosilver (160 to 950 l)

Specification

Type		CVAA/CVBA-A		CVAA	CVA	CVAA			
Cylinder capacity	l	160	200	300	500	750	950		
(AT: Actual water capacity)									
Heating water capacity	l	5.5	5.5	10.0	12.5	29.7	33.1		
Gross volume	l	165.5	205.5	310.0	512.5	779.7	983.1		
DIN registration number		Applied for		9W241/11-13 MC/E					
Continuous output for DHW heating from 10 to 45 °C and a heating water flow temperature of ... at the heating water flow rate stated below	90 °C	kW	40	40	53	70	109	116	
		l/h	982	982	1302	1720	2670	2861	
	80 °C	kW	32	32	44	58	91	98	
		l/h	786	786	1081	1425	2236	2398	
	70 °C	kW	25	25	33	45	73	78	
		l/h	614	614	811	1106	1794	1926	
	60 °C	kW	17	17	23	32	54	58	
		l/h	417	417	565	786	1332	1433	
	50 °C	kW	9	9	18	24	33	35	
		l/h	221	221	442	589	805	869	
	Continuous output for DHW heating from 10 to 60 °C and a heating water flow temperature of ... at the heating water flow rate stated below	90 °C	kW	36	36	45	53	94	101
			l/h	619	619	774	911	1613	1732
80 °C		kW	28	28	34	44	75	80	
		l/h	482	482	584	756	1284	1381	
70 °C		kW	19	19	23	33	54	58	
		l/h	327	327	395	567	923	995	
Heating water flow rate for the stated continuous outputs	m ³ /h	3.0	3.0	3.0	3.0	3.0	3.0		
Standby heat loss	kWh/24 h	1.158/ 0.932	1.394/ 0.997	1.65	1.95	2.28	2.48		
Dimensions									
Length (∅)									
– with thermal insulation	a	mm	582/634	582/634	667	859	1062	1062	
– without thermal insulation		mm	—	—	—	650	790	790	
Width									
– with thermal insulation	b	mm	607/637	607/637	744	923	1110	1110	
– without thermal insulation		mm	—	—	—	837	1005	1005	
Height									
– with thermal insulation	c	mm	1129	1349	1734	1948	1897	2197	
– without thermal insulation		mm	—	—	—	1844	1817	2123	
Height when tilted									
– with thermal insulation		mm	1250/ 1275	1250/ 1275	1825	—	—	—	
– without thermal insulation		mm	—	—	—	1860	1980	2286	
Entire weight incl. thermal insulation		kg	62/65	70/73	156	181	301	363	
Heating surface		m ²	1.0	1.0	1.5	1.9	3.5	3.9	
Connections (male thread)									
Heating water flow and return	R		1	1	1	1	1¼	1¼	
Cold water, DHW	R		¾	¾	1	1¼	1¼	1¼	
DHW circulation	R		¾	¾	1	1	1¼	1¼	
Energy efficiency class			B / A	B / A	B	B	—	—	

Note for continuous output

When designing systems with the specified or calculated continuous output, select a matching circulation pump. The stated continuous output is only achieved when the rated boiler heating output is equal to or greater than the continuous heating output.

Take the following into account when sizing entry points:

The actual dimensions of the DHW cylinder may vary slightly due to manufacturing tolerances.

DHW cylinders (cont.)

Vitocell 100-V, type CVAA/CVBA-A, 160 and 200 l capacity

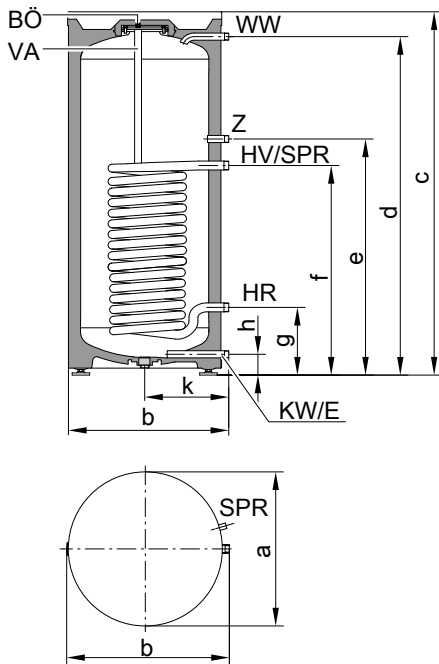

Dimensions

Type		CVAA		CVAB-A		
Cylinder capacity	l	160	200	160	200	
Length (∅)	a	mm	582	582	634	634
Width	b	mm	607	607	637	637
Height	c	mm	1128	1348	1129	1349
	d	mm	1055	1275	1055	1275
	e	mm	889	889	889	889
	f	mm	639	639	639	639
	g	mm	254	254	254	254
	h	mm	77	77	77	77
	k	mm	317	317	347	347

- BÖ Inspection and cleaning aperture
- E Drain outlet
- HR Heating water return
- HV Heating water flow
- KW Cold water
- SPR Clamping device for securing immersion temperature sensors to the cylinder jacket (fixing points for up to 3 temperature sensors)
- VA Protective magnesium anode
- WW DHW
- Z DHW circulation

DHW cylinders (cont.)

Vitocell 100-V, type CVAA, 300 l capacity

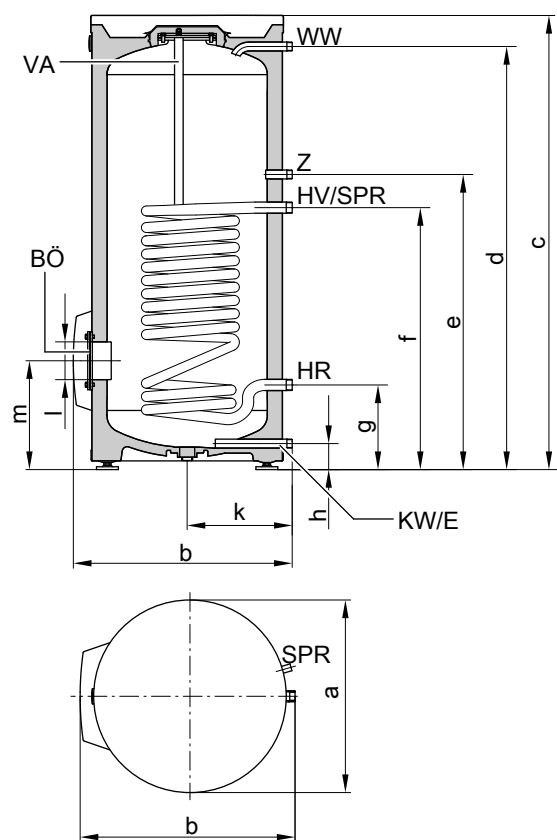

Dimensions

Cylinder capacity			l
Length (∅)	a	mm	667
Width	b	mm	744
Height	c	mm	1734
	d	mm	1600
	e	mm	1115
	f	mm	875
	g	mm	260
	h	mm	76
	k	mm	361
	l	mm	∅ 100
	m	mm	333

- BÖ Inspection and cleaning aperture
- E Drain outlet
- HR Heating water return
- HV Heating water flow
- KW Cold water
- SPR Cylinder temperature sensor of the cylinder temperature controller or temperature controller (internal sensor well diameter 16 mm)
- VA Protective magnesium anode
- WW DHW
- Z DHW circulation

DHW cylinders (cont.)

Vitocell 100-V, type CVA, 500 l capacity

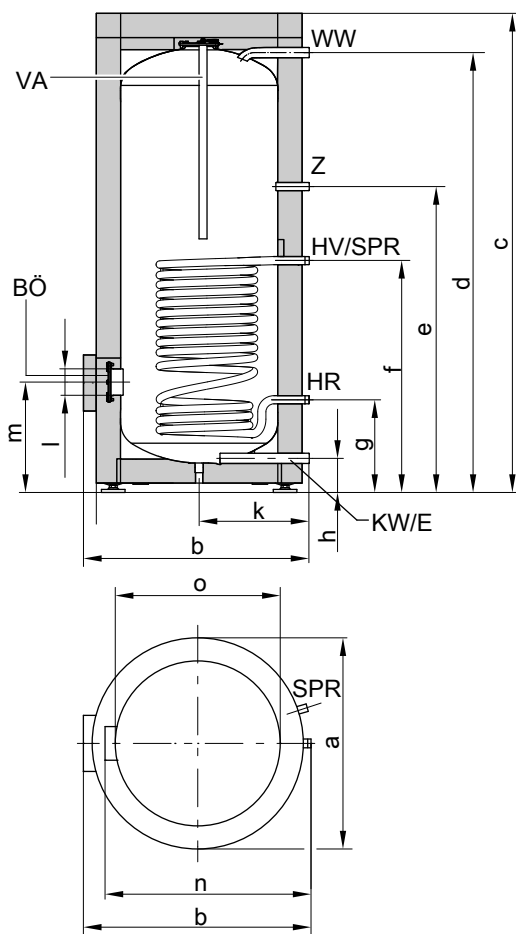

- HV Heating water flow
- KW Cold water
- SPR Cylinder temperature sensor of the cylinder temperature controller or temperature controller (internal sensor well diameter 16 mm)
- VA Protective magnesium anode
- WW DHW
- Z DHW circulation

Dimensions

Cylinder capacity		l	500
Length (Ø)	a	mm	859
Width	b	mm	923
Height	c	mm	1948
	d	mm	1784
	e	mm	1230
	f	mm	924
	g	mm	349
	h	mm	107
	k	mm	455
	l	mm	Ø 100
	m	mm	422
Excl. thermal insulation	n	mm	837
Excl. thermal insulation	o	mm	Ø 650

- BÖ Inspection and cleaning aperture
- E Drain outlet
- HR Heating water return

DHW cylinders (cont.)

Vitocell 100-V, type CVAA, 750 and 950 l capacity

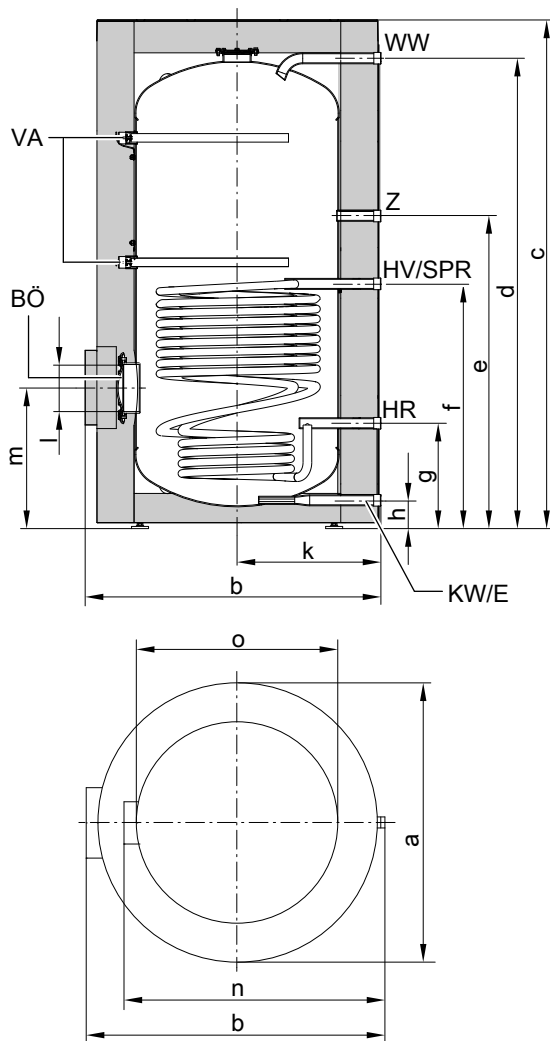

- HV Heating water flow
 KW Cold water
 SPR Clamping device for securing immersion temperature sensors to the cylinder jacket. Retainers for 3 immersion temperature sensors
 VA Protective magnesium anode
 WW DHW
 Z DHW circulation

Dimensions

Cylinder capacity		l	750	950
Length (∅)	a	mm	1062	1062
Width	b	mm	1110	1110
Height	c	mm	1897	2197
	d	mm	1788	2094
	e	mm	1179	1283
	f	mm	916	989
	g	mm	377	369
	h	mm	79	79
	k	mm	555	555
	l	mm	∅ 180	∅ 180
	m	mm	513	502
Excl. thermal insulation	n	mm	1005	1005
Excl. thermal insulation	o	mm	∅ 790	∅ 790

- BÖ Inspection and cleaning aperture
 E Drain outlet
 HR Heating water return

Performance factor N_L

- To DIN 4708
- Cylinder storage temperature T_{cyl} = cold water inlet temperature + 50 K ^{+5 K/-0 K}

Cylinder capacity	l	160	200	300	500	750	950
Performance factor N_L							
at heating water flow temperature							
90 °C		2.5	4.0	9.7	21.0	38.0	44.0
80 °C		2.4	3.7	9.3	19.0	32.0	42.0
70 °C		2.2	3.5	8.7	16.5	25.0	39.0

Information on performance factor N_L

The performance factor N_L depends on the cylinder storage temperature T_{cyl} .

Standard values

- $T_{cyl} = 60\text{ °C} \rightarrow 1.0 \times N_L$
- $T_{cyl} = 55\text{ °C} \rightarrow 0.75 \times N_L$
- $T_{cyl} = 50\text{ °C} \rightarrow 0.55 \times N_L$
- $T_{cyl} = 45\text{ °C} \rightarrow 0.3 \times N_L$

DHW cylinders (cont.)

Peak output (over 10 minutes)

- Relative to performance factor N_L
- DHW heating from 10 to 45 °C

Cylinder capacity	l	160	200	300	500	750	950
Peak output							
at heating water flow temperature							
90 °C	l/10 min	210	262	407	618	850	937
80 °C	l/10 min	207	252	399	583	770	915
70 °C	l/10 min	199	246	385	540	665	875

Max. draw-off rate (over 10 minutes)

- Relative to performance factor N_L
- With reheating
- DHW heating from 10 to 45 °C

Cylinder capacity	l	160	200	300	500	750	950
Max. draw-off rate							
at heating water flow temperature							
90 °C	l/min	21	26	41	62	85	94
80 °C	l/min	21	25	40	58	77	92
70 °C	l/min	20	25	39	54	67	88

Drawable water volume

- Cylinder volume heated to 60 °C
- Without reheating

Cylinder capacity	l	160	200	300	500	750	950
Draw-off rate	l/min	10	10	15	15	20	20
Drawable water volume	l	120	145	240	420	615	800
Water at t = 60 °C (constant)							

Heat-up time

The heat-up times will be achieved when the maximum continuous output of the DHW cylinder is made available at the relevant heating water flow temperature and when DHW is heated from 10 to 60 °C.

Cylinder capacity	l	160	200	300	500	750	950
Heat-up time							
at heating water flow temperature							
90 °C	min	19	19	23	28	23	35
80 °C	min	24	24	31	36	31	45
70 °C	min	34	37	45	50	45	70

DHW cylinders (cont.)

Pressure drop on the heating water side

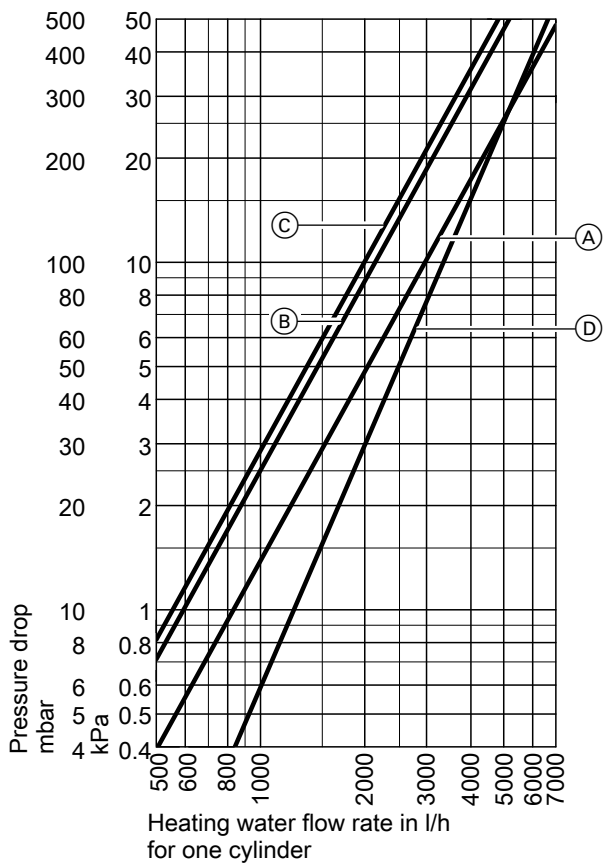

- Ⓐ Cylinder capacity 160 and 200 l
- Ⓑ Cylinder capacity 300 l
- Ⓒ Cylinder capacity 500 l
- Ⓓ Cylinder capacity 750 l and 950 l

Pressure drop on the DHW side

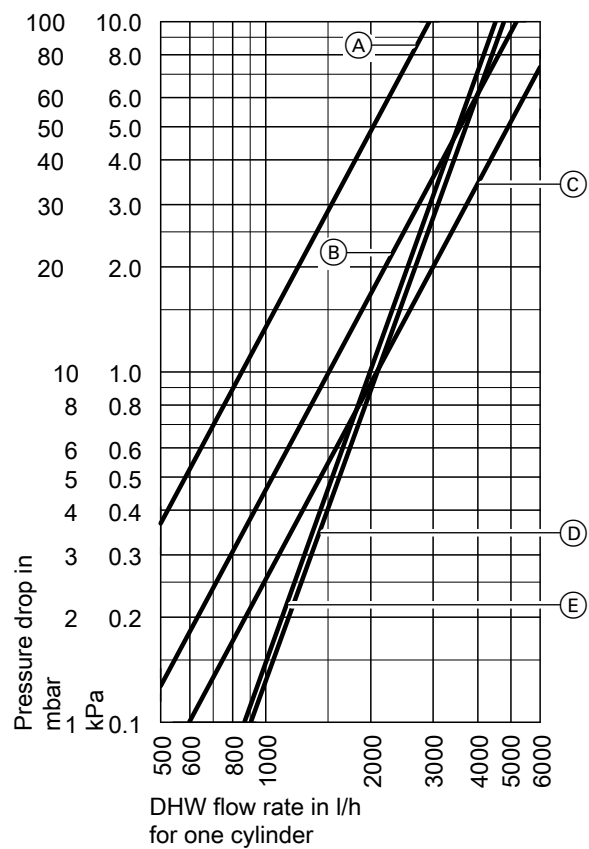

- Ⓐ Cylinder capacity 160 and 200 l
- Ⓑ Cylinder capacity 300 l
- Ⓒ Cylinder capacity 500 l
- Ⓓ Cylinder capacity 750 l
- Ⓔ Cylinder capacity 950 l

DHW cylinders (cont.)

7.8 Vitocell 300-V, type EVIA-A, EVIA-A+

For DHW heating in conjunction with boilers and district heating systems; optionally with an electric heater as an accessory.

Suitable for the following systems:

- DHW temperature up to **95 °C**
- Heating water flow temperature up to **160 °C**
- Operating pressure **on the heating water side** up to **10 bar (1 MPa)**
- Operating pressure **on the DHW side** up to **10 bar (1 MPa)**

Vitocell 100-W, colour: White (160 to 300 l)

Vitocell 100-V, colour: Vitosilver (160 to 500 l)

Type		EVIA-A+/EVIA-A		EVIA-A	EVIA-A
Cylinder capacity (AT: Actual water capacity)	l	160	200	300	500
Heating water capacity	l	7.4	7.4	11.0	12.9
Gross volume	l	167.4	207.4	311.0	512.9
DIN registration number		EVIA-A: 9W71-10MC/E EVIA-A+: Applied for			
Continuous output for DHW heating from 10 to 45 °C and a heating water flow temperature of ... at the heating water flow rate stated below	90 °C kW	46	46	61	69
	l/h	1127	1127	1501	1688
	80 °C kW	38	38	51	58
	l/h	939	939	1252	1414
	70 °C kW	30	30	41	46
	l/h	747	747	998	1128
Continuous output for DHW heating from 10 to 60 °C and a heating water flow temperature of ... at the heating water flow rate stated below	60 °C kW	22	22	30	34
	l/h	547	547	733	830
	50 °C kW	13	13	18	20
	l/h	322	322	434	491
	90 °C kW	39	39	52	59
	l/h	668	668	894	1011
80 °C	kW	31	31	41	46
	l/h	527	527	706	799
70 °C	kW	22	22	29	33
	l/h	372	372	501	568
Heating water flow rate for the stated continuous outputs	m ³ /h	3.0	3.0	3.0	3.0
Standby heat loss	kWh/24 h	0.70/0.90	0.75/0.91	1.06	1.37
Dimensions					
Length (Ø) a					
– with thermal insulation	mm	581	581	667	1022
– without thermal insulation	mm	–	–	–	715
Width b					
– with thermal insulation	mm	605	605	744	1084
– without thermal insulation	mm	–	–	–	954
Height c					
– with thermal insulation	mm	1189	1409	1734	1852
– without thermal insulation	mm	–	–	–	1667
Height when tilted					
– with thermal insulation	mm	1260	1460	1825	–
– without thermal insulation	mm	–	–	–	1690
Entire weight incl. thermal insulation	kg	60	70	105	110
Heating surface	m ²	1.0	1.0	1.5	1.7
Connections (male thread)					
Heating water flow and return	R	1	1	1	1
Cold water, DHW	R	¾	¾	1	1¼
DHW circulation	R	¾	¾	1	1
Energy efficiency class		A+ / A	A+ / A	A	A

Note for continuous output

When designing systems with the specified or calculated continuous output, select a matching circulation pump. The stated continuous output is only achieved when the rated boiler heating output is equal to or greater than the continuous heating output.

Take the following into account when sizing entry points:

The actual dimensions of the DHW cylinder may vary slightly due to manufacturing tolerances.

DHW cylinders (cont.)

160 and 200 l capacity

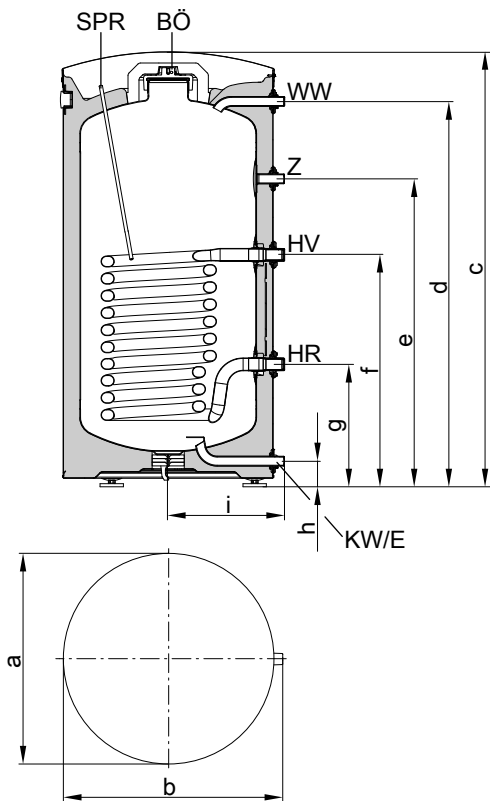

Cylinder capacity	l	160	200
a	mm	581	581
b	mm	605	605
c	mm	1189	1409
d	mm	1055	1275
e	mm	843	885
f	mm	635	635
g	mm	335	335
h	mm	70	70
i	mm	317	317

- BÖ Inspection and cleaning aperture
- E Drain outlet
- HR Heating water return
- HV Heating water flow
- KW Cold water
- SPR Sensor well for cylinder temperature sensor or temperature controller (internal diameter 7 mm)
- WW DHW
- Z DHW circulation

DHW cylinders (cont.)

300 litre capacity

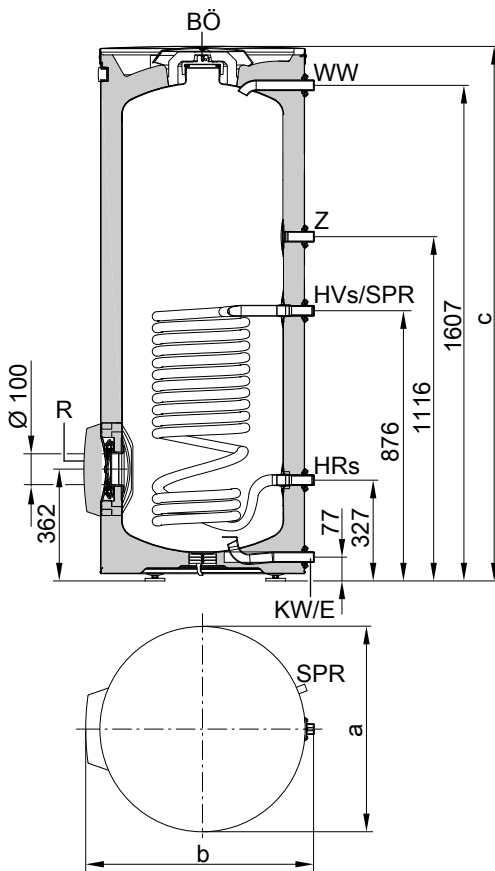

Cylinder capacity	l	300
a	mm	667
b	mm	744
c	mm	1734

- BÖ Inspection and cleaning aperture
- E Drain outlet
- HR Heating water return
- HV Heating water flow
- KW Cold water
- R Additional cleaning aperture and immersion heater
- SPR Sensor well for cylinder temperature sensor or temperature controller (internal diameter 17 mm)
- WW DHW
- Z DHW circulation

DHW cylinders (cont.)

500 litre capacity

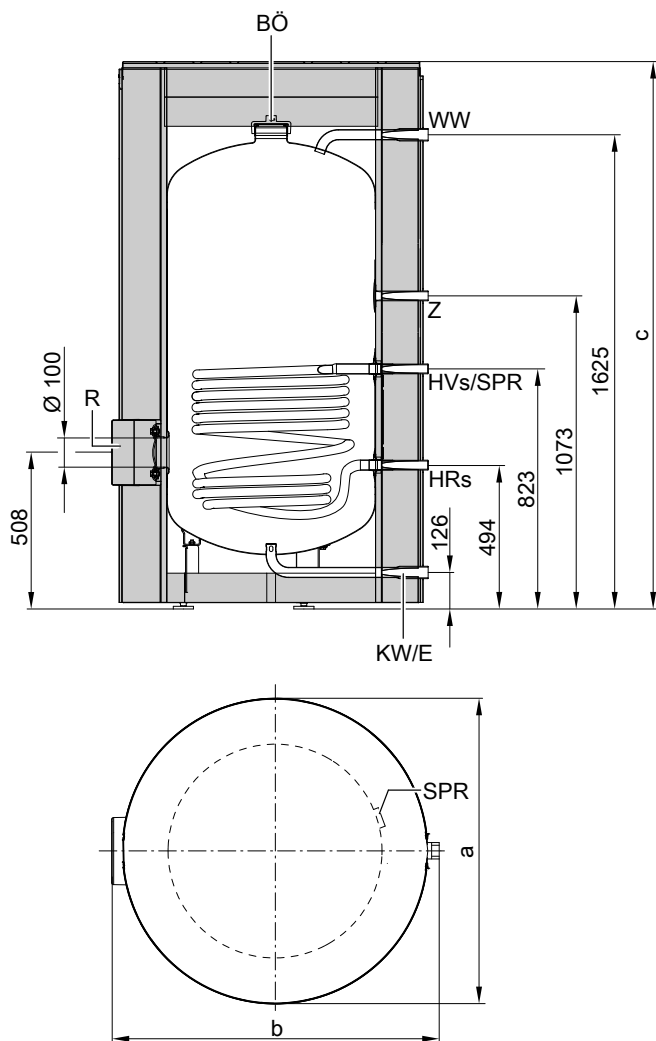

Cylinder capacity	l	500
a	mm	1022
b	mm	1084
c	mm	1852

- BÖ Inspection and cleaning aperture
- E Drain outlet
- HR Heating water return
- HV Heating water flow
- KW Cold water
- R Additional cleaning aperture and immersion heater
- SPR Clamping device for securing immersion temperature sensors to the cylinder jacket. Retainers for 3 immersion temperature sensors per clamping device.
- WW DHW
- Z DHW circulation

Performance factor N_L

To DIN 4708.

Cylinder storage temperature T_{cyl} = cold water inlet temperature

+ 50 K ^{+5 K/-0 K}

Cylinder capacity	l	160	200	300	500
Performance factor N_L at heating water flow temperature					
90 °C		3.5	6.6	10.5	21.5
80 °C		3.1	5.6	10.0	19.5
70 °C		2.3	4.6	9.5	17.0

DHW cylinders (cont.)

Information on performance factor N_L

The performance factor N_L depends on the cylinder storage temperature T_{cyl} .

Standard values

- $T_{cyl} = 60\text{ °C} \rightarrow 1.0 \times N_L$
- $T_{cyl} = 55\text{ °C} \rightarrow 0.75 \times N_L$
- $T_{cyl} = 50\text{ °C} \rightarrow 0.55 \times N_L$
- $T_{cyl} = 45\text{ °C} \rightarrow 0.3 \times N_L$

Peak output (over 10 minutes)

Relative to performance factor N_L .

DHW heating from 10 to 45 °C.

Cylinder capacity	l	160	200	300	500
Peak output (l/10 min) at heating water flow temperature					
90 °C		251	340	430	634
80 °C		237	314	419	600
70 °C		207	285	408	556

Max. draw-off rate (over 10 minutes)

Relative to performance factor N_L .

With reheating.

DHW heating from 10 to 45 °C.

Cylinder capacity	l	160	200	300	500
Max. draw-off rate (l/min) at heating water flow temperature					
90 °C		25.1	34.0	43.0	63.4
80 °C		23.7	31.4	41.9	60.0
70 °C		20.7	28.5	40.8	55.6

Drawable water volume

Cylinder volume heated to 60 °C.

Without reheating.

Cylinder capacity	l	160	200	300	500
Draw-off rate	l/min	10	10	15	15
Drawable water volume	l	133	155	240	420
Water at $t = 60\text{ °C}$ (constant)					

Heat-up time

The specified heat-up times will be achieved when the maximum continuous output of the DHW cylinder is made available at the relevant heating water flow temperature and when DHW is heated from 10 to 60 °C.

Cylinder capacity	l	160	200	300	500
Heat-up time (min.) at heating water flow temperature					
90 °C		17	19	21	25
80 °C		20	24	30	33
70 °C		30	37	40	46

DHW cylinders (cont.)

Pressure drop

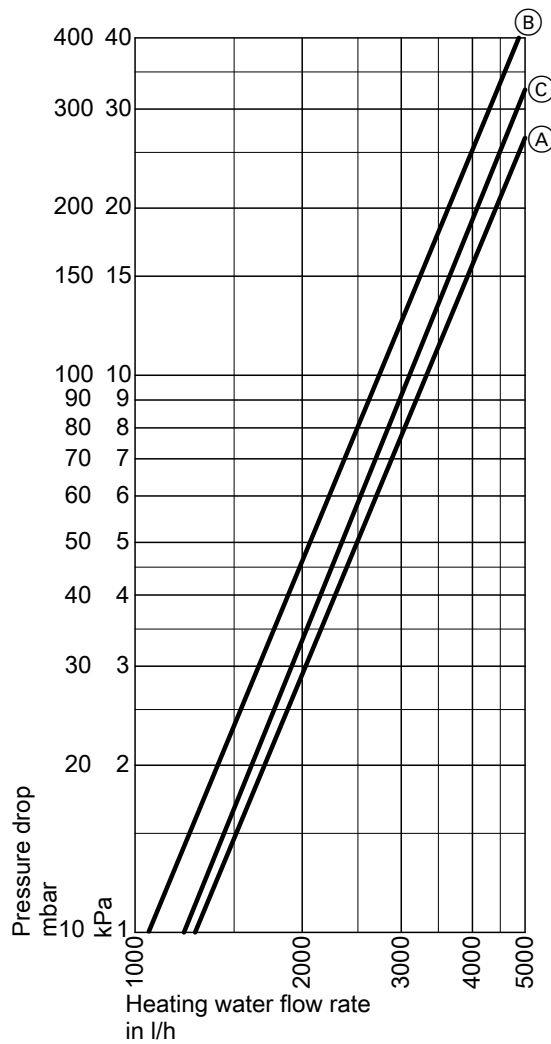

Pressure drop on the heating water side

- (A) Cylinder capacity 160 l and 200 l
- (B) Cylinder capacity 300 l
- (C) Cylinder capacity 500 l

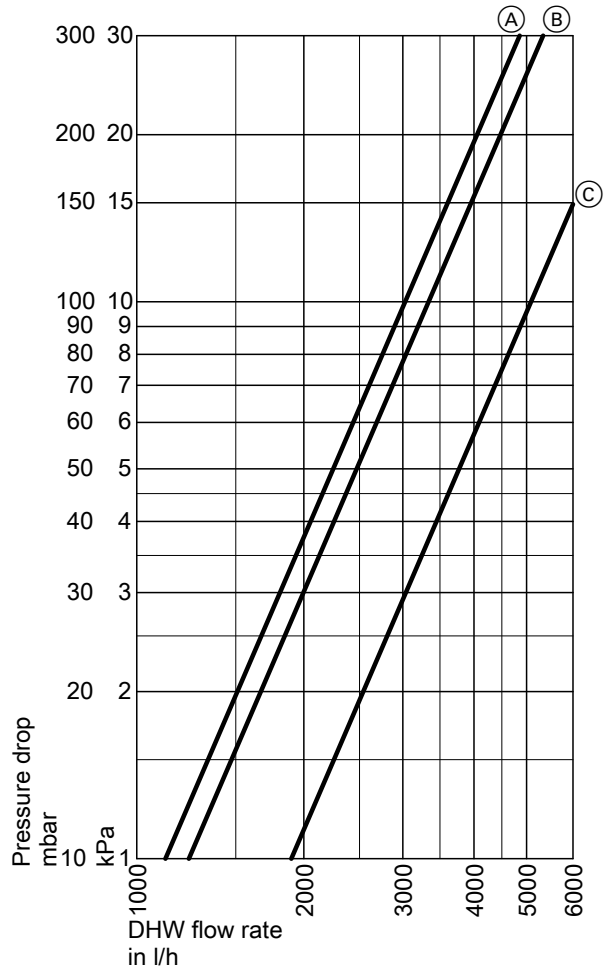

Pressure drop on the DHW side

- (A) Cylinder capacity 160 l and 200 l
- (B) Cylinder capacity 300 l
- (C) Cylinder capacity 500 l

Installation accessories

8.1 Solar-Divicon and solar pump assembly

Versions

See chapter "Sizing the circulation pump".

A Solar-Divicon and a solar pump assembly are required for systems with a 2nd pump circuit or with a bypass circuit.

Note

The Solar-Divicon, type PS10, can be fitted to Vitocell 140-E/160-E and Vitocell 340-M/360-M by means of a connection set. See separate datasheets.

Version	Part no. for type			
	PS10	PS20	P10	P20
– High efficiency circulation pump with PWM control – Without solar control unit	Z012020	Z012027	Z012022	Z012028
– High efficiency circulation pump with PWM control – SDIO/SM1A electronics module	Z017690	—	—	—
– High efficiency circulation pump with PWM control – Vitosolic 100, type SD1	Z012018	—	—	—

Structure

Solar-Divicon and solar pump assembly are prefitted and tested for tightness with the following components:

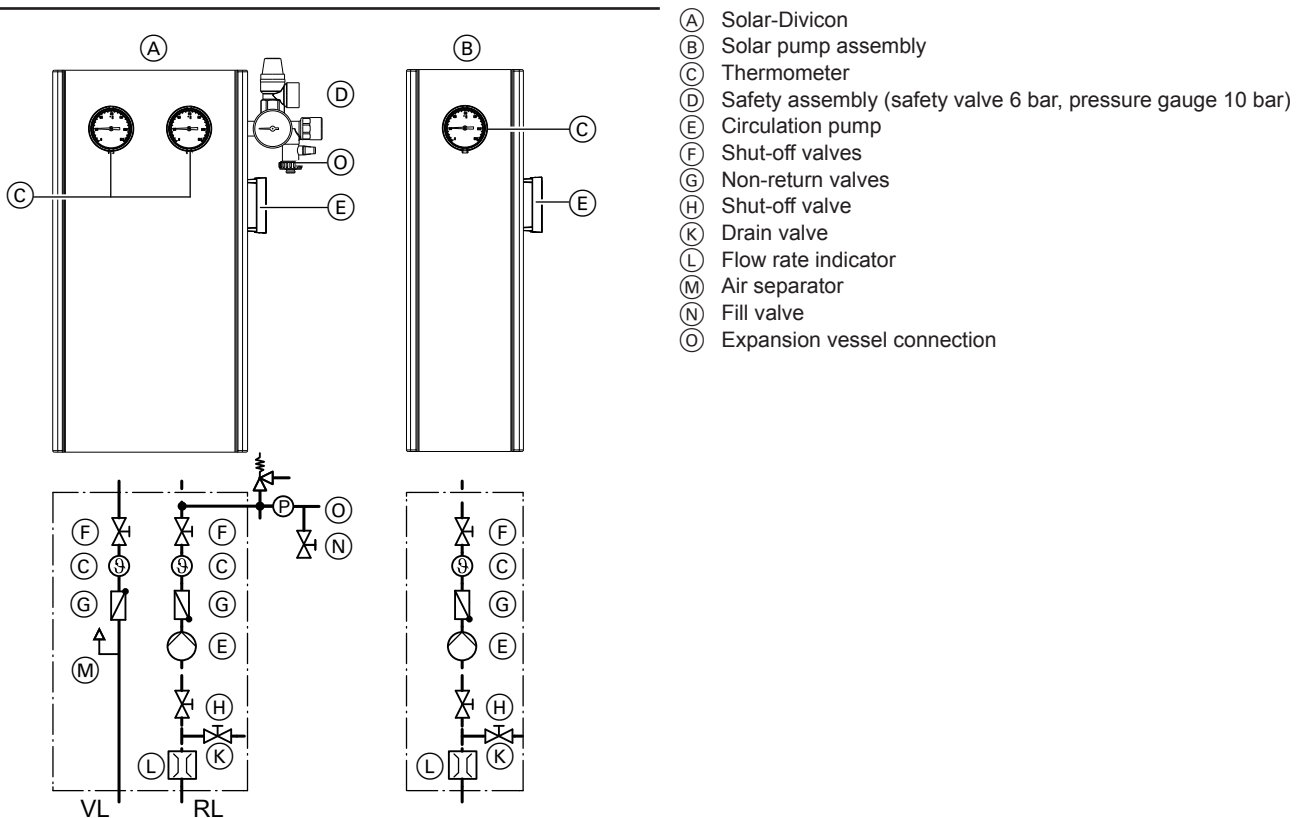

RL Return
VL Flow

Safety valve in conjunction with collectors with temperature-dependent shutdown

Up to a system height of 20 m, the Solar-Divicon with the 6 bar safety valve can be used.

Above a system height of 20 m, the safety valve can be replaced by an 8 bar safety valve (see accessories).

Installation accessories (cont.)

Clearances

Solar pump assembly to the right of the Solar-Divicon

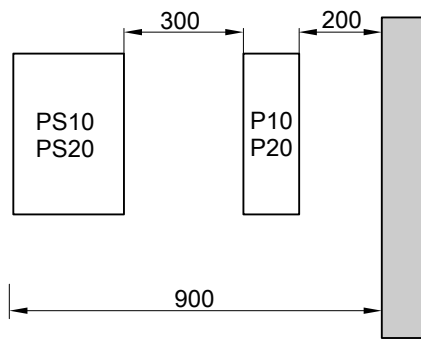

Solar pump assembly to the left of the Solar-Divicon

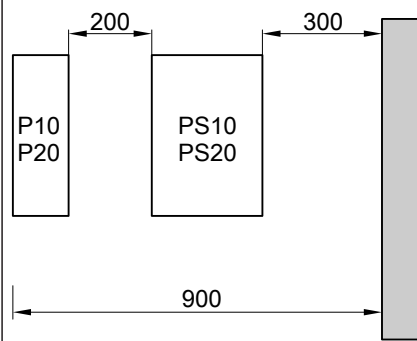

Specification

Type		PS10, P10	PS20, P20
Wilo circulation pump			
High efficiency circulation pump		PARA 15/7.0	PARA 15/7.5
Energy efficiency index EEI		≤ 0.2	≤ 0.21
Rated voltage	V~	230	230
Power consumption			
– Min.	W	3	3
– Max.	W	45	73
Flow rate indicator	l/min	1 to 13	5 to 35
Safety valve (solar)			
– At the factory	bar/MPa	6/0.6	6/0.6
– Installation of 8 bar safety valve (accessory)	bar/MPa	8/0.8	8/0.8
Max. operating temperature in return line	°C	120	120
Max. operating temperature in flow line	°C	150	150
Max. operating pressure	bar/MPa	10/1	10/1
Connections (locking ring fitting/double O-ring)			
– Solar circuit	mm	22	22
– Expansion vessel	mm	22	22

Installation accessories (cont.)

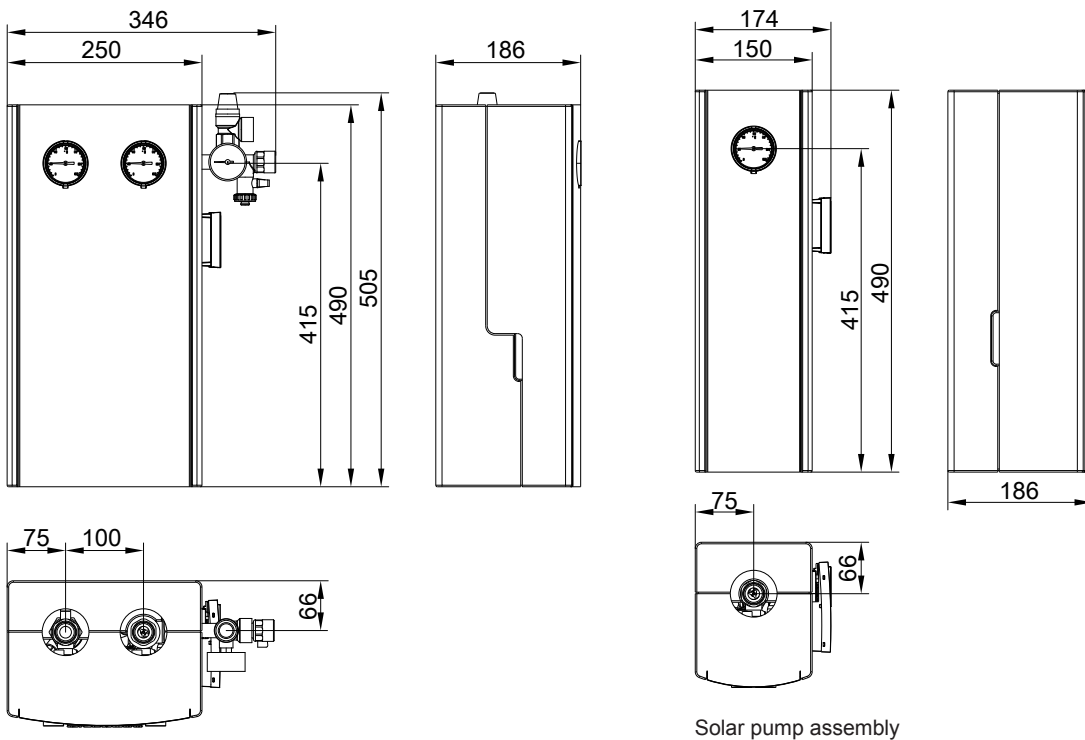

Solar-Divicon

Solar pump assembly

Pump curves

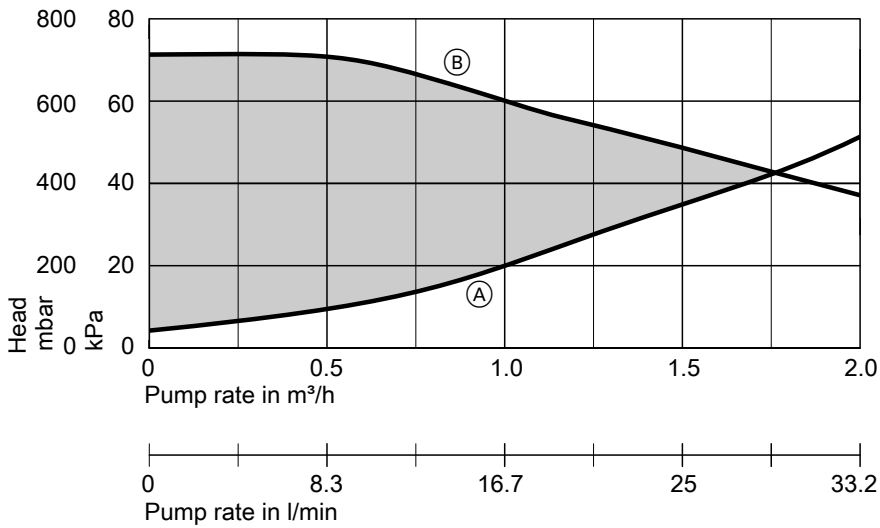

High efficiency circulation pump, types PS10 and P10

- (A) Pressure drop curve
- (B) Max. head

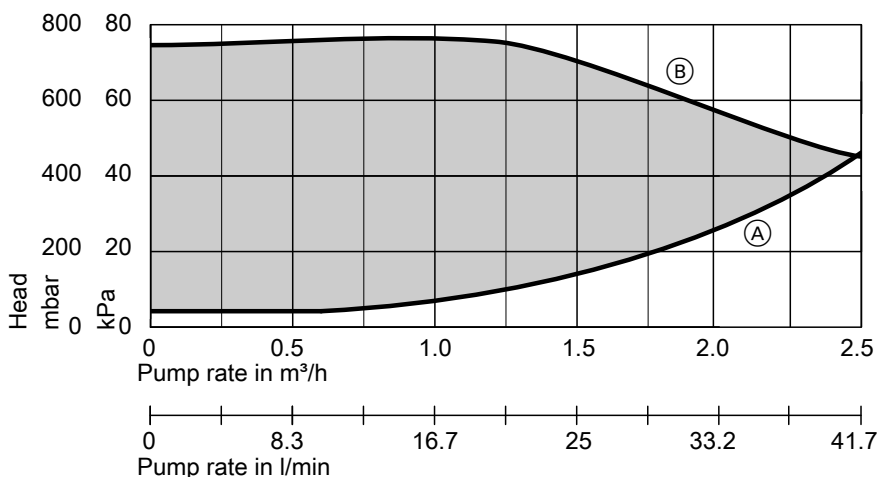

High efficiency circulation pump, types PS20 and P20

- (A) Pressure drop curve
- (B) Max. head

Heat meter

Part no. Z013684

For solar thermal systems with "Typfocor LS" heat transfer medium

- For wall mounting in conjunction with Solar-Divicon, type PS10
- For installation on DHW cylinder with fitted Solar-Divicon, type PS10

- Capture of flow and return temperatures
- Capture of flow rate, nominal flow rate 1.5 m³/h
- Indication of energy amount, heating output, flow rate, flow and return temperatures

Solar safety valve 8 bar

In solar thermal systems, the 6 bar safety valves fitted at the factory can be replaced with 8 bar safety valves.

Part no. ZK02881

Safety valve IG ½ x IG 1 for

- Solar-Divicon PS10
- Vitosolar 300-F
- Vitocell 100-U, type CVUB/CVUC

- Vitodens 242-F
- Vitodens 343-F

Part no. ZK02458

Safety valve IG ¾ x IG 1 for

- Solar-Divicon, type PS20
- Solar transfer stations

8.2 Hydraulic accessories

Connecting tee

Part no. 7172731

For connecting the expansion vessel or stagnation cooler in the Solar-Divicon flow line.
With locking ring fitting and double O-ring 22 mm.

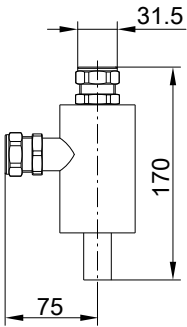

Connection line

Part no. 7143745

For the connection between Solar-Divicon and the solar cylinder.
Stainless steel corrugated pipe with thermal insulation and protective foil.

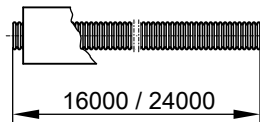

Corrug. pipe ext. Ø 21.2

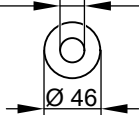

Installation kit for connection line

Only required in conjunction with the connecting cable, part no. 7143745.

Part no.	DHW cylinder	a	mm	b	mm
7373476	Vitocell 300-B, 500 l		272		40
7373475	Vitocell 100-B, 300 l Vitocell-300-B, 300 l		190		42
7373474	Vitocell 100-B, 400 and 500 l		272		72
7373473	Vitocell 140/160-E Vitocell 340/360-M		—		—

Part no. 7373473

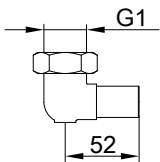

Components:

- 2 threaded elbows
- Gaskets
- 2 locking ring fittings
- 8 pipe sleeves

Installation accessories (cont.)

Part nos. 7373474 to 476

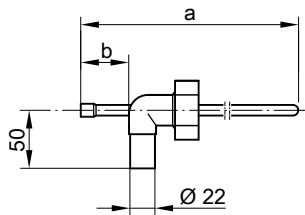

Components:

- 2 threaded elbows (1 elbow with sensor well, 1 elbow without sensor well)
- Gaskets
- 2 locking ring fittings
- 8 pipe sleeves

Note

When using installation kits, the threaded elbow (standard delivery of DHW cylinder) for the installation of the cylinder temperature sensor is **not** required.

Manual air vent valve

Part no. 7316263

Locking ring fitting with air vent valve.
Install at the highest point of the system.

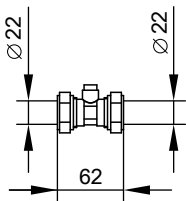

Air separator

Part no. ZK03779

Installation in the flow line of the solar circuit, preferably upstream of the inlet into the DHW cylinder.

Note

Included in standard delivery with solar packs

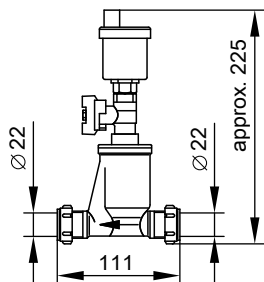

Quick-action air vent valve (with tee)

Part no. ZK03780

Install at the highest point of the system.
With shut-off valve and locking ring fitting

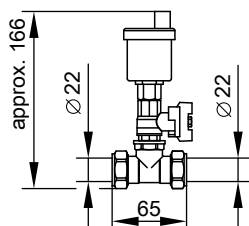

Installation accessories (cont.)

Connecting cable

Part no. 7316252

Stainless steel corrugated pipe with thermal insulation and locking ring fitting.

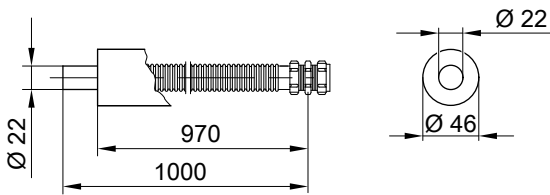

Solar flow and return lines

Stainless steel corrugated pipes with thermal insulation and protective foil, locking ring fittings and sensor lead:

- 6 m long
Part no. 7373477
- 12 m long
Part no. 7373478
- 15 m long
Part no. 7419567

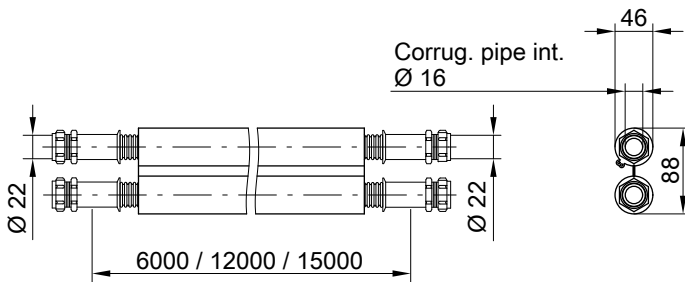

Solar line roof outlet

- Colour: terracotta
Part no. ZK02013
- Colour: black
Part no. ZK02014
- Colour: brown
Part no. ZK02015

For solar flow line and solar return line, for tiled roof cover, 15 to 65°
Pivoting outlet; connection from the bottom, left or right

Connection accessories for residual lengths of solar flow and return lines

Connecting kit

Part no. 7817370



For extending the connecting lines:

- 2 pipe sleeves
- 8 O-rings
- 4 support rings
- 4 profile clips

Connection set

Part no. 7817368



For joining the connection lines to the pipework of the solar thermal system:

- 2 pipe sleeves
- 4 O-rings
- 2 support rings
- 2 profile clips

Installation accessories (cont.)

Connection set with locking ring fitting

Part no. 7817369



For joining the connection lines to the pipework of the solar thermal system:

- 2 pipe sleeves with locking ring fitting
- 4 O-rings
- 2 support rings
- 2 profile clips

Solar expansion vessel

Design and function

With shut-off valve and fixings

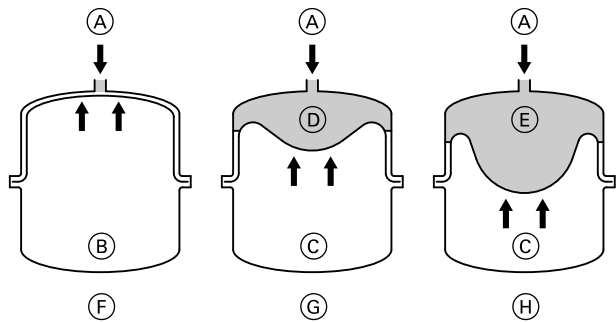

- (A) Heat transfer medium
- (B) Nitrogen charge
- (C) Nitrogen buffer
- (D) Minimum safety seal 3 l
- (E) Safety seal
- (F) Delivered condition (pre-charge pressure 4.5 bar, 0.45 MPa)
- (G) Solar thermal system filled, without heat effect
- (H) At maximum pressure and the highest heat transfer medium temperature

A solar expansion vessel is a sealed vessel where the gas space (nitrogen charge) is separated from the space containing liquid (heat transfer medium) by a diaphragm and the pre-charge pressure is subject to the system height.

Specification

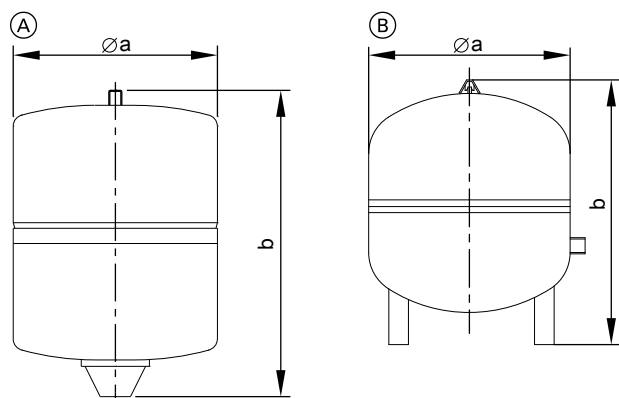

Expansion vessel	Part no.	Capacity l	Pre-charge pressure bar (MPa)	Ø a mm	b mm	Connection	Weight kg
(A)	7248241	18	4.5 (0.45)	280	370	R ¾	7.5
	7248242	25	4.5 (0.45)	280	490	R ¾	9.1
	7248243	40	4.5 (0.45)	354	520	R ¾	9.9
(B)	7248244	50	4.5 (0.45)	409	505	R 1	12.3
	7248245	80	4.5 (0.45)	480	566	R 1	18.4

Note

Included in standard delivery with solar packs

Line regulating valve

Part no. ZK01510

For hydraulically balancing solar collector arrays

- With locking ring fitting Ø 22 mm
- Max. operating temperature: 200 °C
- For max. 5 collectors per row

Line regulating valve

Part no. ZK01511

For hydraulically balancing solar collector arrays

- With locking ring fitting Ø 22 mm
- Max. operating temperature: 200 °C
- For 5 to 12 collectors per row

Installation accessories (cont.)

Stagnation cooler

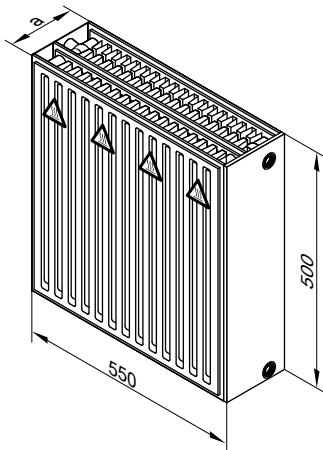

To protect the system components from excess temperatures in the event of stagnation.
With a plate without any flow as contact protection.

Part no.	Z007429	Z007430
Type	21	33
Dim. a	105 mm	160 mm
Output at 75/65 °C	482 W	834 W
Cooling capacity at 140/80 °C	964 W	1668 W

For detailed information, see chapter "Safety equipment".

Solar thermal systems with Vitosol-FM/-TM

If the system pressure is adjusted according to manufacturer's instructions, a stagnation cooler is not required.

Automatic thermostatic mixing valve

Part no. 7438940

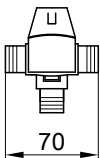

For limiting the DHW outlet temperature in DHW heating systems without DHW circulation pipe

Specification

Connections	G	1
Temperature range	°C	35 to 60
Max. temperature of the medium	°C	95
Operating pressure	bar/MPa	10/1.0

Thermostatic DHW circulation set

Part no. ZK01284

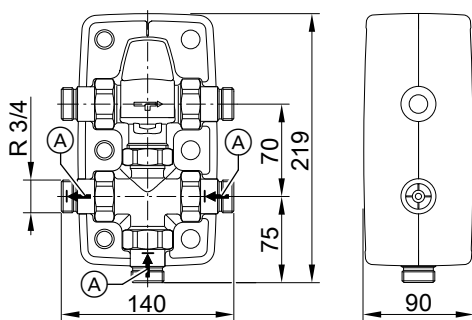

For limiting the DHW outlet temperature in DHW heating systems with DHW circulation pipe

- Automatic thermostatic mixing valve with bypass line
- Integral non-return valves
- Removable insulation shells

Specification

Connections	R	3/4
Weight	kg	1.45
Temperature range	°C	35 to 60
Max. temperature of the medium	°C	95
Operating pressure	bar	10
	MPa	1

(A) Non-return valve

3-way diverter valve

Part no. 7814924

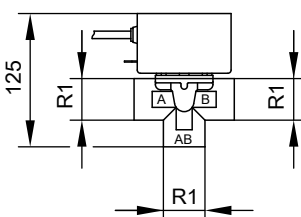

- For systems with central heating backup
- With electric drive

Threaded DHW circulation fitting

Part no. 7198542

For connecting a DHW circulation pipe to the DHW connection of the Vitocell 340-M and 360-M.

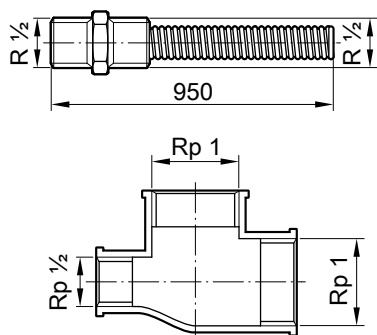

8.3 Heat transfer medium

Fill valve

Part no. 7316261

For flushing, filling and draining the system.
With locking ring fitting.

Note

Part of the standard delivery of solar packages.

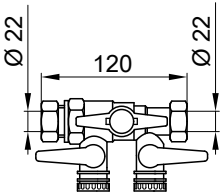

Fill station

Part no. 7188625

For filling the solar circuit

- Hose, 0.5 m long (intake side)
- Connection hose, 2.5 m long (2 pce)
- Packing crate (can be used as flushing tank)

Components:

- Self-priming impeller pump (30 l/min)
- Dirt filter (intake side)

Filling trolley

Part no. 7172590

For filling the primary circuit.

- Hose, inlet side (0.5 m)
- Connection hose (2 pce, each 3.0 m)
- Canister for heat transfer medium

Components:

- Self-priming impeller pump (30 l/min)
- Dirt filter, inlet side

Solar manual fill pump

Part no. ZK02962

For topping up and raising the pressure.

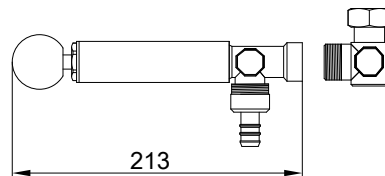

Heat transfer medium "Tyfocor LS"

Part nos. 7159727 and 7159729

- Ready-mixed to -28 °C
- Part no. 7159727
25 l in a disposable container
- Part no. 7159729
200 l in a disposable container

Tyfocor LS can be mixed with Tyfocor G-LS.

8.4 Other accessories

Transport aid

Part no. ZK01512

- For installation on the flat-plate collector
- For installation support with a crane or when using a rope for installing and securing collectors on the roof
- Components:
 - 2 plastic holders
 - 2 carabiners

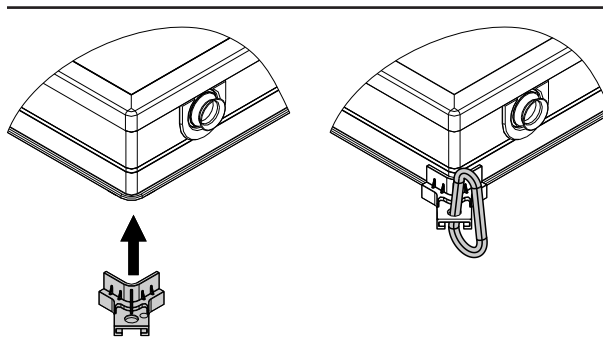

Design information regarding installation

9.1 Snow load and wind load zones

The collectors and the fixing system must be designed in such a way that they can withstand any snow and wind loads that may occur. EN 1991, 3/2003 and 4/2005, identifies various snow and wind load zones for every country in Europe.

The Vitodesk 100 SOLSTAT calculation software is available for calculating snow and wind loads as a function of building characteristics. The software enables snow and wind loads to be calculated as a function of location and assists in determining the required installation system.

9.2 Distance from the edge of the roof

Observe the following for installation on pitched roofs:

- If the distance from the top edge of the collector array to the ridge of the roof is greater than 1 m, we recommend installing a snow guard.
- Never install collectors close to roof overhangs where snow is likely to slide off. If necessary, install a snow guard.

Note

The additional loads due to accumulated snow on collectors or snow guards must be taken into account in the structural calculations for the building.

Certain parts of the roof are subject to special requirements:

- Corner area (A): limited on two sides by the end of the roof
- Edge area (B): limited on one side by the end of the roof

See the diagrams below.

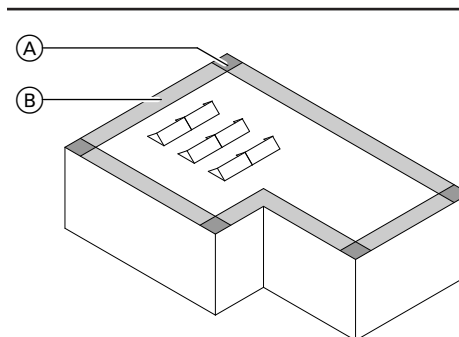

The minimum width (1 m) of corner and edge areas must be calculated in accordance with EN 1991 and must be observed. Allow for increased wind turbulence in these areas.

Note

For the calculation of clearances on flat roofs, the Viessmann "Vitodesk 100 SOLSTAT" calculation program is available at www.viessmann.com.

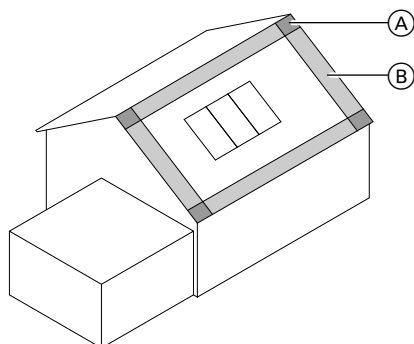

9.3 Routing pipework

During the design phase, ensure the pipes are installed with a fall from the collector. This ensures better steam expulsion characteristics in the solar thermal system as a whole in the event of stagnation. The thermal load exerted on all system components is reduced (see page 140).

9.4 Equipotential bonding/lightning protection of the solar thermal system

Connect the solar circuit pipework with an electrical conductor in the lower part of the building in accordance with VDE [or local] regulations. The integration of the collector system into a new or existing lightning protection facility or the provision of local equipotential bonding must only be carried out by **authorised personnel**. Local conditions must be taken into consideration.

9.5 Thermal insulation

The thermal insulation material provided must withstand the operating temperatures to be expected and must be permanently protected against the influence of moisture. Some open pore insulation material that can be subjected to high thermal loads cannot provide reliable protection against moisture produced by condensation. The high temperature versions of close-cell insulating hoses offer adequate protection against moisture, but have a maximum loading temperature of approx. 170 °C. However, the connections at the collector can be subjected to temperatures up to 200 °C (Vitosol-F flat-plate collector). In switching collectors (Vitosol-FM/-TM), the maximum achievable temperature in the collector area is approx. 145 °C to 170 °C.

The thermal insulation of the solar lines routed outdoors must be protected against pecking damage from birds and gnawing by small animals, as well as against UV radiation. A cover (e.g. metal sheath) protecting the insulation against damage by small animals also provides UV protection.

9.6 Solar lines

- Use stainless steel pipe or commercially available copper pipe and bronze fittings.
- Metal seals (conical or locking rings and compression fittings) are suitable for solar lines. Should alternative seals be used, such as flat gaskets, their manufacturer must give an assurance of their adequate resistance to glycol, pressure and temperature. In case of connections with hemp seals, use a pressure and temperature-resistant sealant. Use hemp connections as little as possible due to their comparatively high air permeability and never in the immediate vicinity of collectors.
- Generally, copper lines in solar circuits are brazed or joined by press fittings. Soft solder could be weakened, particularly near the collectors, due to the maximum temperatures that may occur there. Metal sealing connections, locking ring fittings or Viessmann push-fit connections with double O-rings are the most suitable.

Note

If using press fittings, ensure the seal rings are suitable (resistant to glycol and temperature). Only use seal rings that have been approved by the manufacturer.

- All components to be used must be resistant to the heat transfer medium.

Note

Fill solar thermal systems only with Viessmann "Tyfocor LS" heat transfer medium.

- Take high temperature differentials in the solar circuit into consideration when routing and securing pipes. At pipe sections that may be subject to steam loads, temperature differentials of up to 200 K can be expected; at the other pipe sections, 120 K can be expected.

Note

Insulate pipes that lead through the roof timber construction with fire protection insulation.

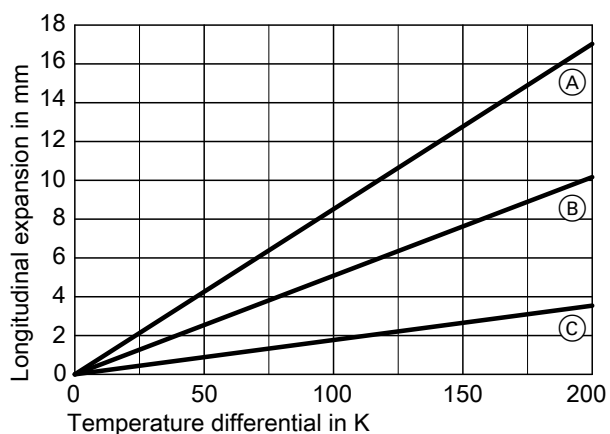

- Ⓐ 5 m pipe length
- Ⓑ 3 m pipe length
- Ⓒ 1 m pipe length

- Route the solar connection lines through a suitable roof outlet (ventilation tile). For suitable accessories for the solar connection line roof outlet, see page 100.

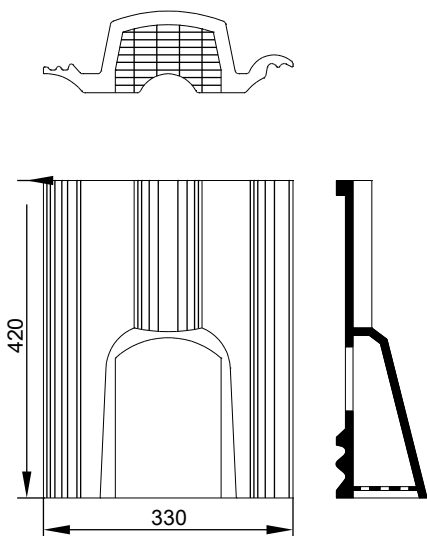

Roof tile type	Ventilation cross-section in cm ²
Double Roman tile	32
Double-S	30
Tanus tile	27
Harz tile	27

9.7 Collector fixing

Due to the many varieties available, solar collectors can be installed in almost all types of building:

- In a new build or modernisation project
- On pitched roofs, flat roofs and on walls
- Freestanding on the ground
- Integrated into the roof surface

Viessmann offers universal fixing systems to simplify installation. These fixing systems are suitable for virtually any form of roof and roof cover as well as for installation on flat roofs and walls.

Design information regarding installation (cont.)

Above roof installation

In above roof systems, the collectors and the roof structure are connected. At each fixing point, a rafter hook, rafter flange or rafter anchor penetrates the water-carrying level below the collector. This means the anchoring must be completely rainproof and secure. The fixing points, and therefore also any possible defects, are no longer visible post-installation. Maintain the minimum clearances from the roof edge in accordance with EN 1991 (see page 100).

Required roof area

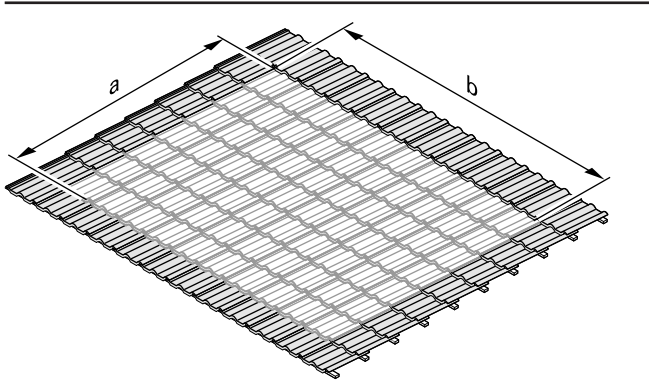

For collector installation, vertical pipes and dimensions of required roof area, see table. For the installation version with horizontal pipes, interchange dimensions a and b.

Add dimension b for each additional collector.

Collector	Vitosol-FM/-F		Vitosol 200-TM, type SPEA		Vitosol 300-TM, type SP3C	
	SV	SH	1.63 m ²	3.26 m ²	1.51 m ²	3.03 m ²
a in mm	2380	1056	2244	2244	2240	2240
b in mm	1056 + 16	2380 + 16	1194 + 44	2364 + 44	1053 + 89	2061 + 89

Flat roof installation

During installation of the collectors (freestanding or horizontal), the minimum clearances from the edge of the roof in accordance with the standard must be observed (see page 100). If the roof size necessitates a split array, ensure that sections of the same size are created.

The collectors can be secured on any solid substructure or on concrete slabs.

Note

On pitched roofs with a low angle of inclination, the collector supports can be secured to the rafter anchors (see page 104) with the mounting rails.

Check the structural condition of the roof.

When installing collectors on concrete slabs, secure them with additional ballast against slippage, tipping and lifting.

Slippage is the movement of the collectors on the roof surface due to wind, because of insufficient friction between the roof surface and the collector fixing system. Collectors can be secured by guy ropes or by being fixed to other roof structures.

Ballast and max. load on the substructure

Observe the calculations in accordance with EN 1991-1-4 and EN 1991-1-1.

Note

The Viessmann "Vitodesk 100 SOLSTAT" calculation program is available at www.viessmann.com to assist with calculations.

Installation on walls

Technical Building Regulations

For the rules regarding the implementation of solar thermal systems, see the list of German Building Regulations (LTB) [or local regulations].

This combines the technical rules of all German Federal States for the use of linear supported glazing (TRLV) issued by the Deutsches Institut für Bautechnik (DIBt). This includes flat-plate and tube collectors. It primarily concerns the protection of pedestrian and traffic areas against falling glass.

Design information regarding installation (cont.)

Overhead glazing

Glazing with an angle of inclination greater than 10°

- No additional safety measures to protect against falling glass parts are required for flat-plate and tube collectors with an angle of inclination greater than 10°.

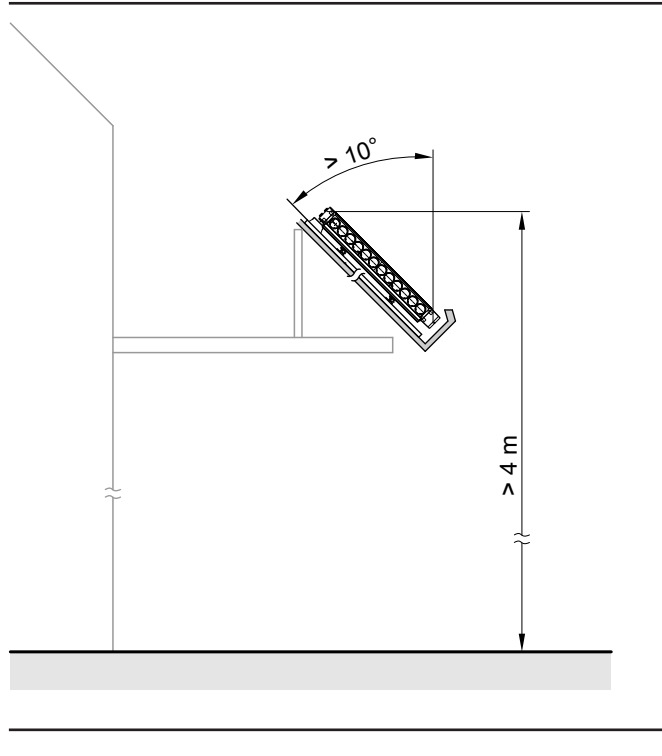

Vertical glazing

Glazing with an angle of inclination smaller than 10°

- The TRLV does not apply to vertical glazing with an upper edge higher than max. 4 m above a traffic area.
No additional safety measures to protect against falling glass parts are required for flat-plate and tube collectors with an angle of inclination less than 10°.
- For vertical glazing with an upper edge higher than 4 m above a traffic area, suitable measures must be taken to effectively prevent glass from falling (e.g. netting or trays below; see the following diagrams).

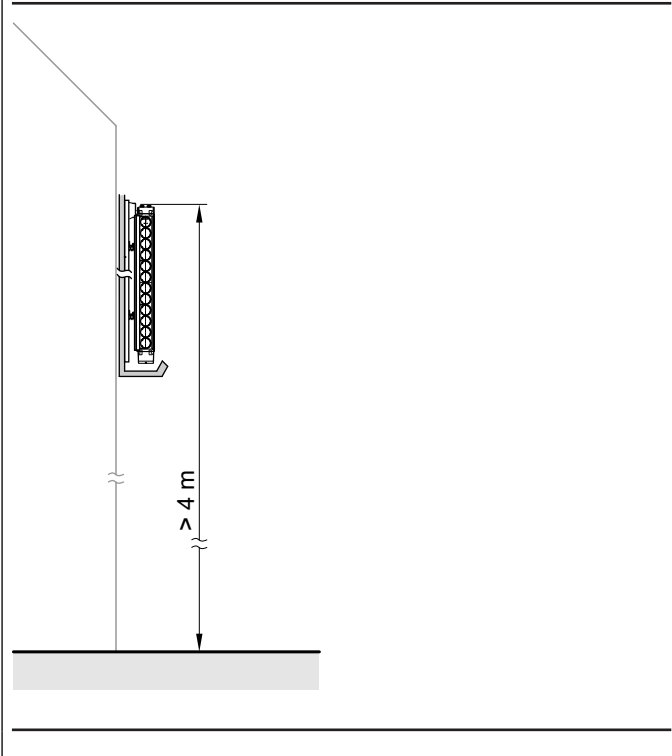

Design information regarding installation on pitched roofs — above roof installation

10.1 Above roof installation with rafter anchors

General information

Observe the information on securing collectors on page 103.

- This fixing system can be used universally for all standard roof covers and is designed for wind speeds of up to 150 km/h and the following snow loads:

Vitosol-FM/-F, type SV: up to 4.80 kN/m²

Vitosol-FM/-F, type SH: up to 2.55 kN/m²

Vitosol 300-TM: up to 2.55 kN/m²

Information on Vitosol-FM/-F, type SV

For snow loads up to 2.55 kN/m², each collector is secured to 2 mounting rails. For snow loads of 4.80 kN/m², a third rail is required. The rails are the same for all snow and wind loads.

- The fixing system comprises:
 - Rafter anchor
 - Mounting rails
 - Clamping brackets
 - Screws
 - Seals

- Guarantees a permanently safe load transmission to the roof structure. This reliably prevents tile breakages. In regions with higher snow loads, we always recommend this fixing system.
- The rafter anchors are available in 2 versions:
 - Rafter anchor, low tile, 195 mm high
 - Rafter anchor, high tile, 235 mm high
- To enable the mounting rails to be secured to the rafter anchors, maintain a clearance of **max. 100 mm** between the top edge of the rafters or counter batten and the top edge of the roof tile.
- In conjunction with above roof insulation, secure the rafter anchors on site.
When doing so, the screws must reach **at least 120 mm** into the load bearing wood structure, to ensure sufficient load bearing capacity.
- Any unevenness in the roof can be compensated for by adjusting the rafter anchors.

Criteria for selecting the fixing system:

- Snow load
- Rafter spacing
- Roof with or without counter battens (different screw lengths)

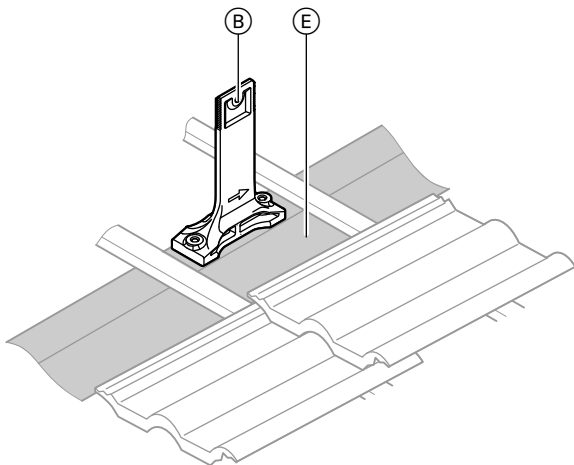

- Ⓑ Rafter anchor
- Ⓔ Rafter

For tiled roof cover, Viessmann offers 2 installation options:
Using a plastic replacement tile

Adapting the roof tile with an angle grinder

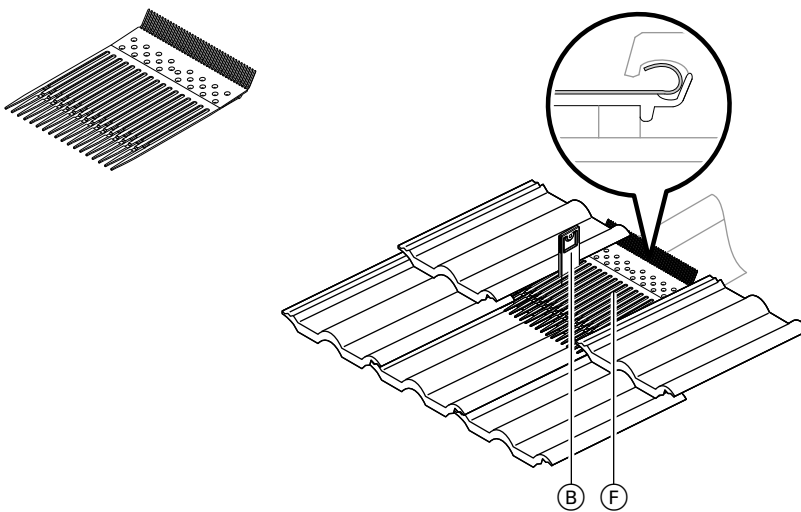

- Ⓑ Rafter anchor
- Ⓕ Plastic replacement tile

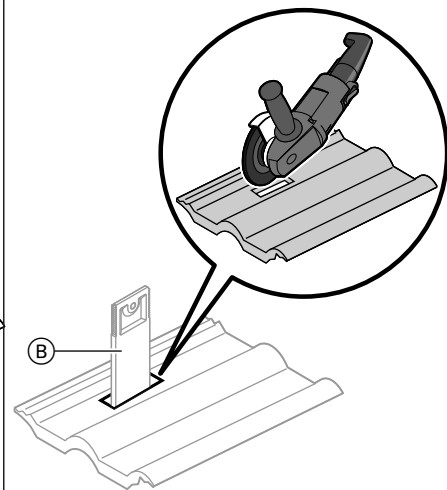

- Ⓑ Rafter anchor

Affixed seal

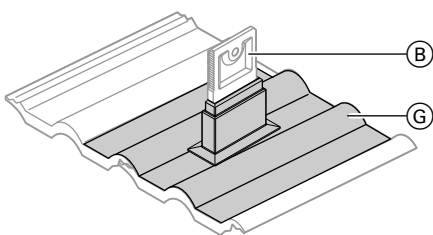

- Ⓑ Rafter anchor
- Ⓖ Seal (fully affixed)

Design information regarding installation on pitched roofs — above roof installation (cont.)

Above roof installation with mounting brackets e.g. on sheet steel roofs

The fixing system comprises:

- Mounting brackets
- Mounting rails
- Clamping brackets
- Screws

The mounting brackets are secured with screws to the on-site support elements which are matched to the individual sheet steel roof. Mounting rails are fitted directly to the mounting brackets.

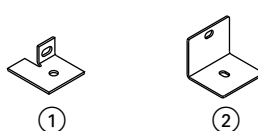

- ① Vitosol-TM, for vertical installation
- ② Vitosol-TM, for horizontal installation
Vitosol-FM/-F, for vertical and horizontal installation

Vitosol-FM/-F flat-plate collectors

Vertical and horizontal installation

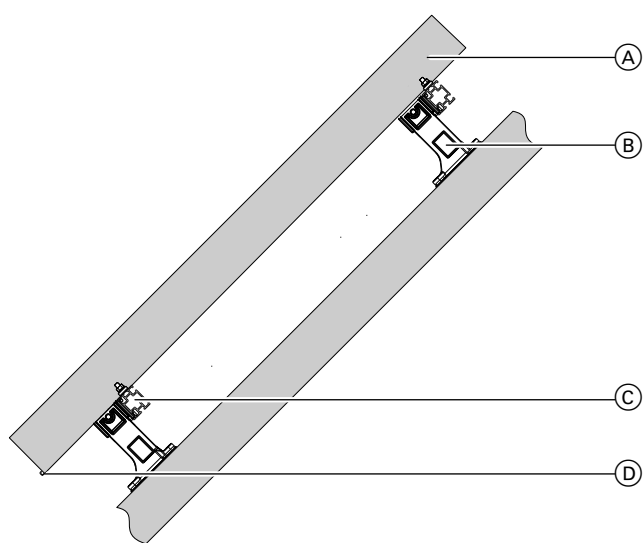

- (A) Collector
- (B) Rafter anchor
- (C) Mounting rail
- (D) Mounting plate

Design information regarding installation on pitched roofs — above roof installation (cont.)

Vitosol 300-TM vacuum tube collectors, type SP3C

Vertical installation

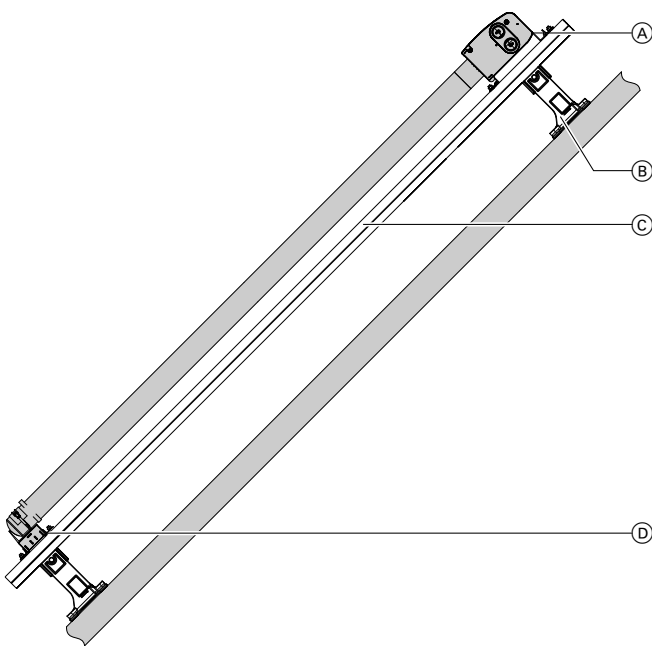

- Ⓐ Collector
- Ⓑ Rafter anchor
- Ⓒ Mounting rail
- Ⓓ Tube retainer

Horizontal installation

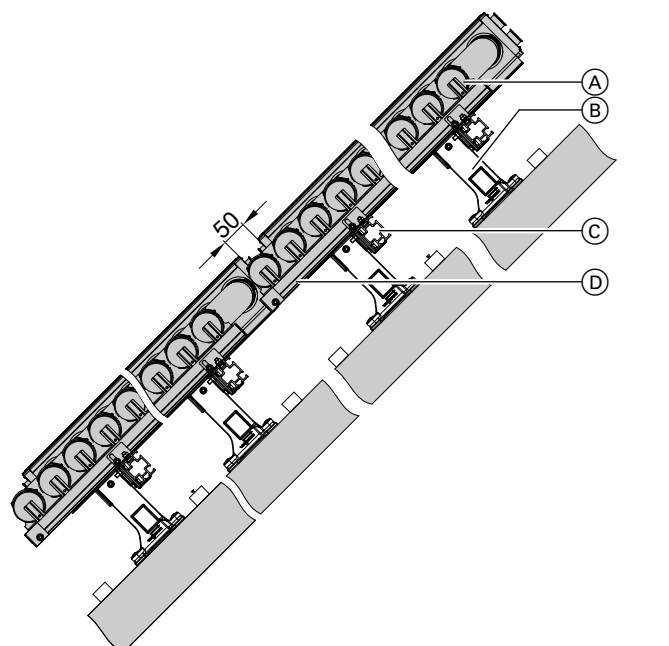

- Ⓐ Collector
- Ⓑ Rafter anchor
- Ⓒ Mounting rail
- Ⓓ Tube retainer

Vitosol 200-TM vacuum tube collectors, type SPEA

Vertical installation

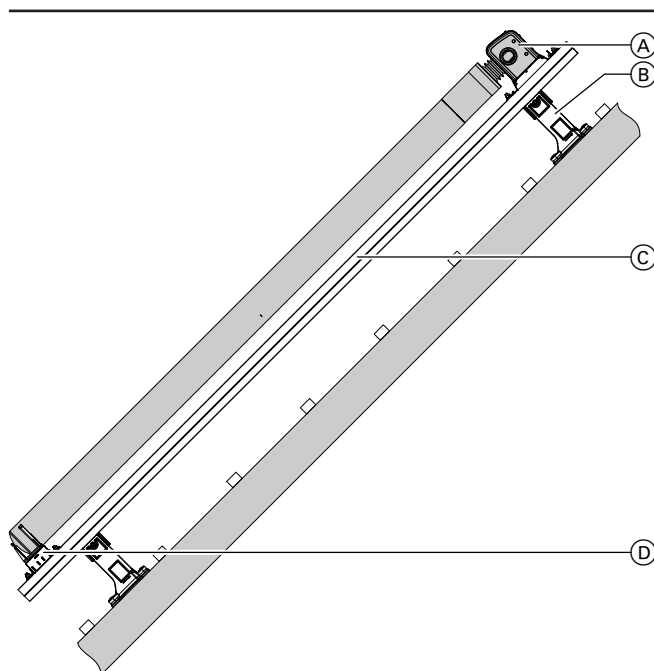

- (A) Collector
- (B) Rafter anchor
- (C) Mounting rail
- (D) Tube retainer

Horizontal installation

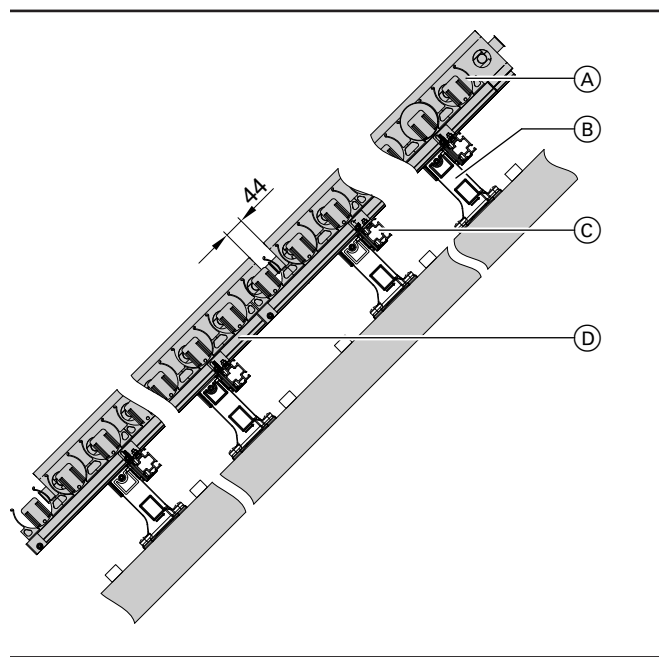

- (A) Collector
- (B) Rafter anchor
- (C) Mounting rail
- (D) Tube retainer

Collector supports on pitched roofs

(For rafter anchors in conjunction with collector supports from the flat roof installation range, see page 114).

On pitched roofs with a low angle of inclination, the collector supports can be secured to the rafter anchors with the mounting rails.

Check the structural condition of the roof.

10.2 Above roof installation with rafter hooks

General information

Observe the information on securing collectors on page 103.

- This fixing system is suitable for roofs with **standard roof tiles** (except Harz tiles and double-S tiles). It is designed for wind speeds up to 150 km/h and snow loads up to 1.25 kN/m²
- The fixing system comprises:
 - Rafter hooks
 - Mounting rails
 - Clamping brackets
 - Screws
- Guarantees a permanently safe load transmission to the roof structure. This reliably prevents tile breakages.
- In conjunction with above roof insulation, secure the rafter hooks on site.

When doing so, the screws must reach **at least 80 mm** into the load bearing wood structure, to ensure sufficient load bearing capacity.
- Any unevenness in the roof can be compensated for by adjusting the rafter hooks.

Criteria for selecting the fixing system:

- Snow load
- Roof with or without counter battens

Rafter hook

- The rafter hooks are fully zinc-plated at high temperature to protect against corrosion (galvanised, 70 µm coating thickness).
- On roofs **without counter battens**, the rafter hooks are mounted directly on the rafters.
- On roofs **with counter battens**, the rafter hook is secured directly to the counter batten with a support bracket.

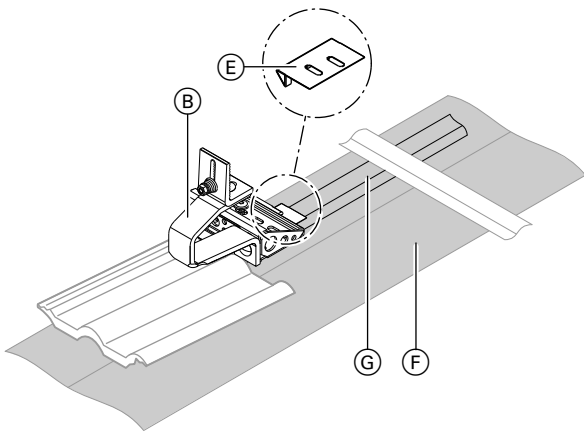

- Ⓑ Rafter hook
- Ⓔ Support bracket
- Ⓕ Rafter
- Ⓖ Counter batten

Vitosol-FM/-F flat-plate collectors

Vertical and horizontal installation

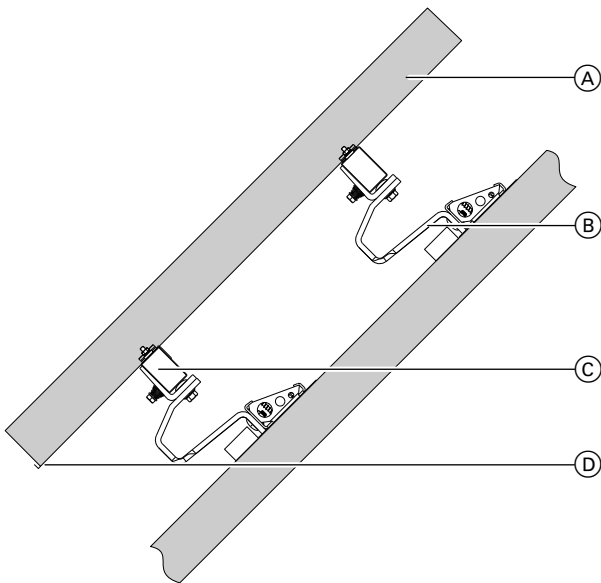

- Ⓐ Collector
- Ⓑ Rafter hook
- Ⓒ Mounting rail
- Ⓓ Mounting plate

Vitosol 300-TM vacuum tube collectors, type SP3C

Vertical installation

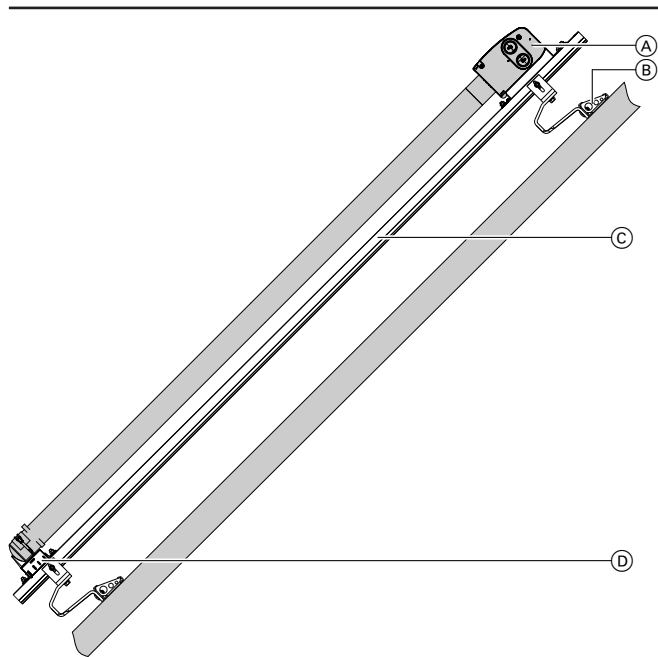

- (A) Collector
- (B) Rafter hooks
- (C) Mounting rail
- (D) Tube retainer

Horizontal installation

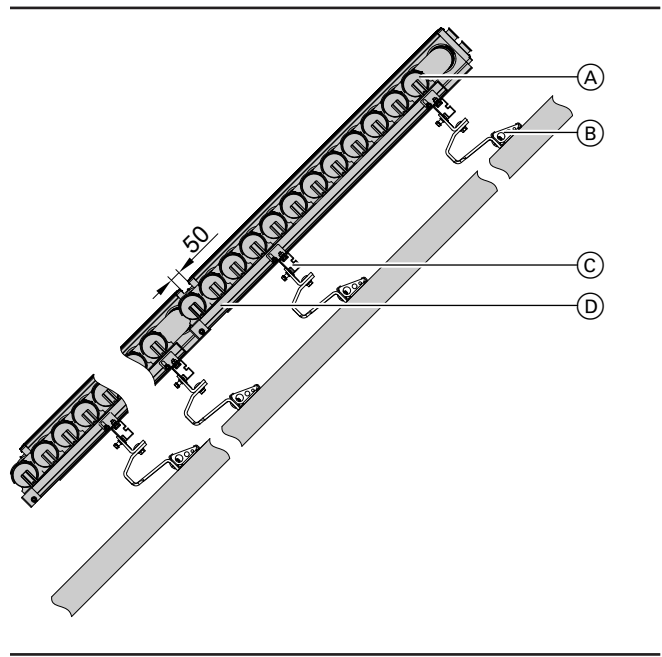

- (A) Collector
- (B) Rafter hooks
- (C) Mounting rail
- (D) Tube retainer

Vitosol 200-TM vacuum tube collectors, type SPEA

Vertical installation

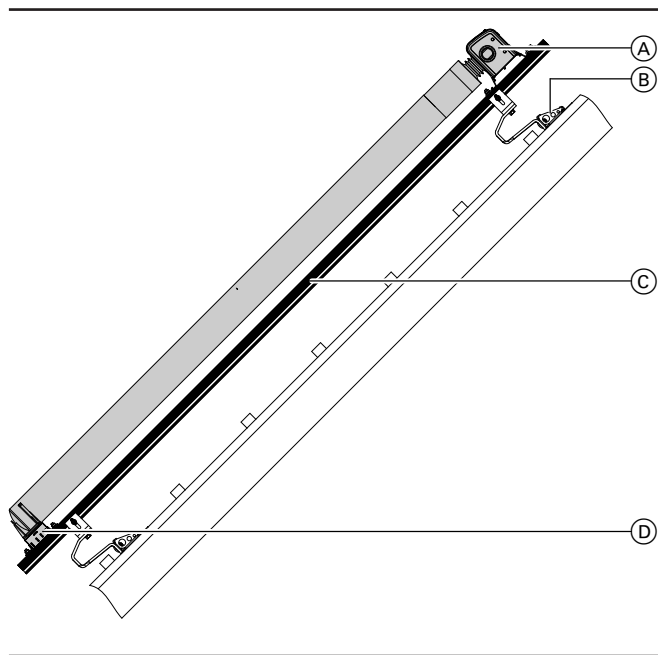

- (A) Collector
- (B) Rafter hooks
- (C) Mounting rail
- (D) Tube retainer

Horizontal installation

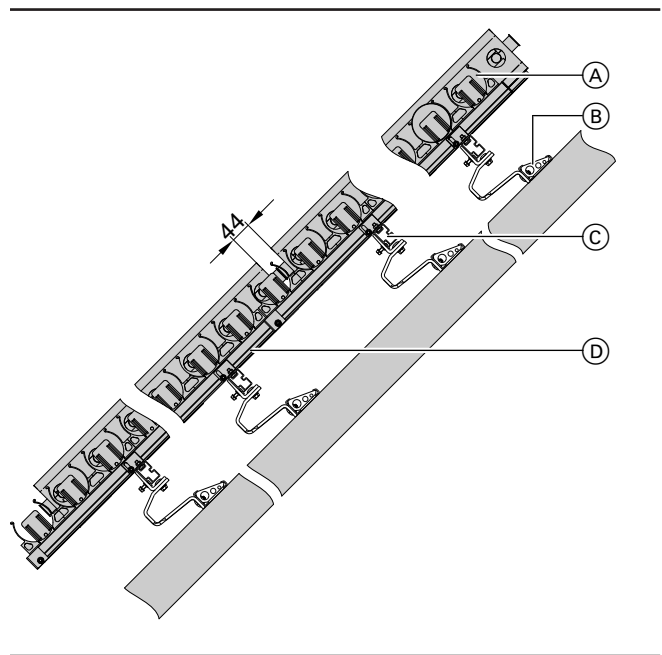

- (A) Collector
- (B) Rafter hooks
- (C) Mounting rail
- (D) Tube retainer

10

10.3 Above roof installation with rafter flanges

General information

- This fixing system is suitable for roofs with **plain tiles** and **slate cover**. It is designed for wind speeds up to 150 km/h and snow loads up to 1.25 kN/m².
- The fixing system comprises:
 - Rafter flanges
 - Mounting rails
 - Clamping brackets
 - Screws
- The rafter flanges can be secured directly to the rafters, the battens, counter battens or the timber shell.
- Guarantees a permanently safe load transmission to the roof structure. This reliably prevents tile breakages.
- In conjunction with above roof insulation, secure the rafter flanges on site.
When doing so, the screws must reach **at least 80 mm** into the load bearing wood structure, to ensure sufficient load bearing capacity.
- Any unevenness in the roof can be compensated for by adjusting the rafter flanges.

Criteria for selecting the fixing system:

- Roof cover
- Snow load

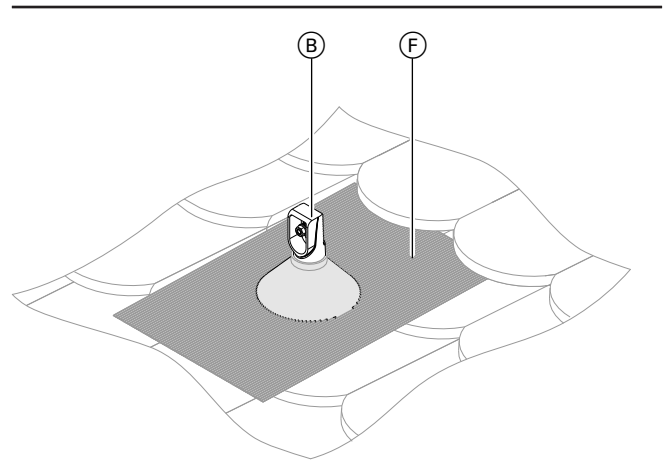

- Ⓑ Rafter flange
- Ⓕ Seal (fully affixed)

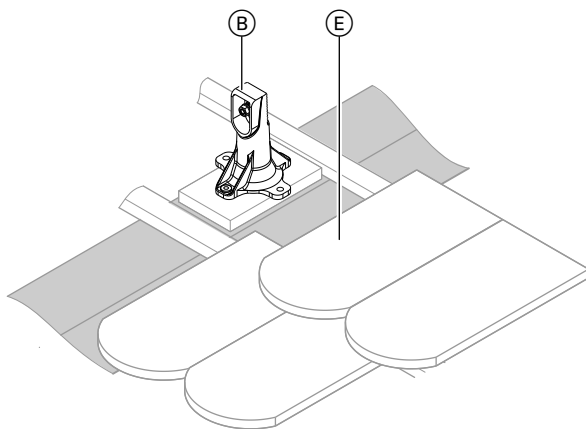

- Ⓑ Rafter flange
- Ⓔ Rafter

Vitosol-FM/-F flat-plate collectors

Vertical and horizontal installation

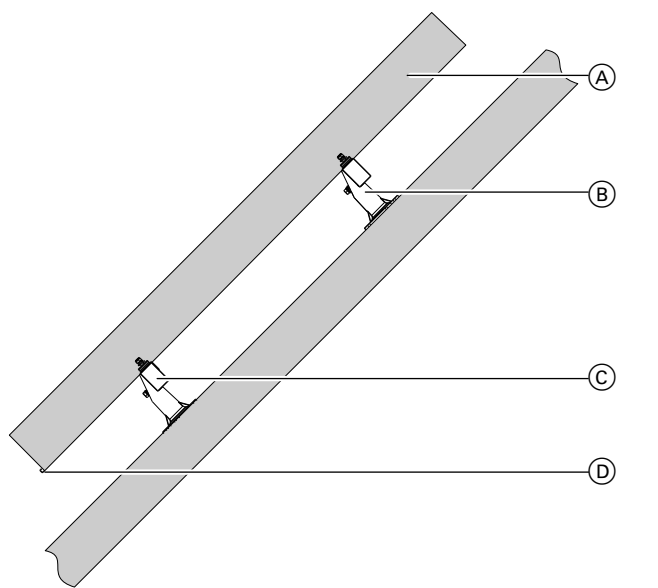

- (A) Collector
- (B) Rafter flange
- (C) Mounting rail
- (D) Mounting plate

Vitosol 300-TM vacuum tube collectors, type SP3C

Vertical installation

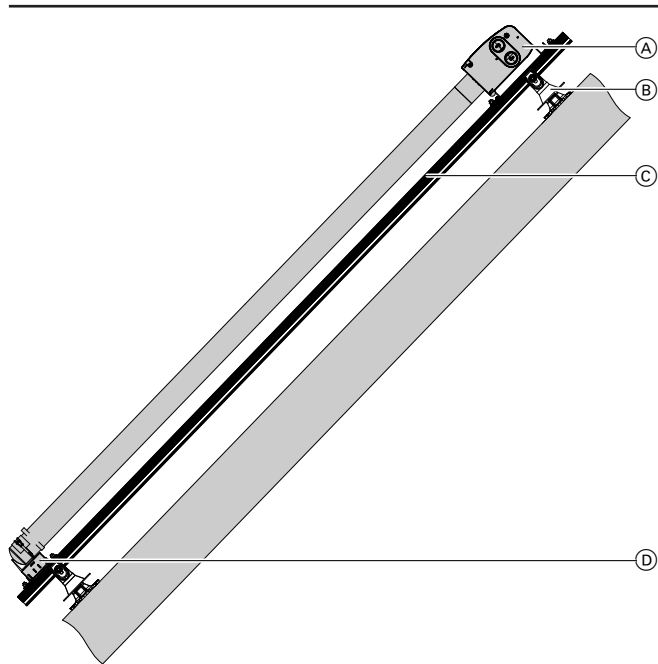

- (A) Collector
- (B) Rafter flange
- (C) Mounting rail
- (D) Tube retainer

Horizontal installation

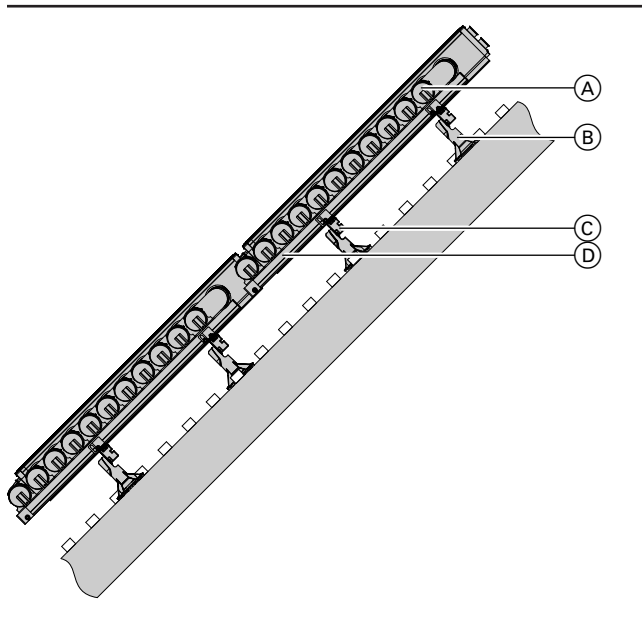

- (A) Collector
- (B) Rafter flange
- (C) Mounting rail
- (D) Tube retainer

10

Vitosol 200-TM vacuum tube collectors, type SPEA

Vertical installation

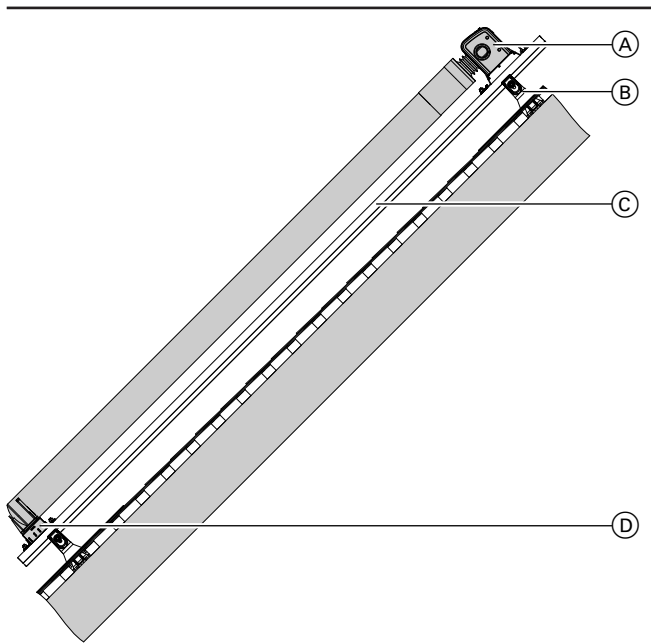

- (A) Collector
- (B) Rafter flange
- (C) Mounting rail
- (D) Tube retainer

Horizontal installation

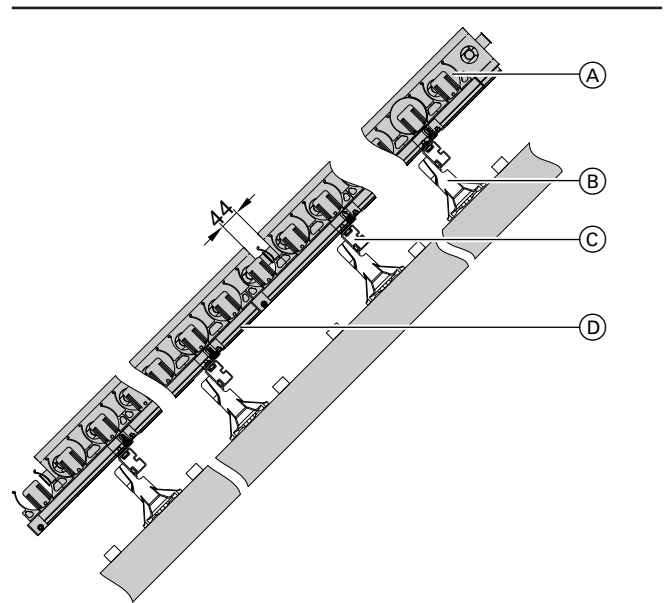

- (A) Collector
- (B) Rafter flange
- (C) Mounting rail
- (D) Tube retainer

10.4 Above roof installation for corrugated sheet roofs

Observe the information on securing collectors on page 103.

- This fixing system is suitable for corrugated sheet roofs.
- The fixing system comprises:
 - Fixing hooks
 - Mounting rails
 - Clamping brackets
 - Screws.
- The loads are transmitted to the roof structure in a number of ways, including via the fixing hooks and the roof cover. As the load transmission can vary greatly, the possibility of damage in conjunction with applied loads can not be fully excluded. We therefore recommend providing safety measures on site to ensure the tightness of the roof.

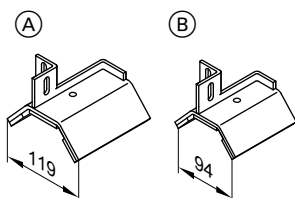

- (A) Mounting hook for corrugated sheet profiles 5 and 6
- (B) Mounting hook for corrugated sheet profile 8

10.5 Above roof installation for sheet metal roofs

General information

Observe the information on securing collectors on page 103.

The fixing system comprises:

- Mounting bracket
- Mounting rails
- Clamping brackets
- Screws

The mounting brackets are secured with screws to the on-site support elements (matched to the individual sheet steel roof).

Mounting rails are fitted directly to the mounting brackets.

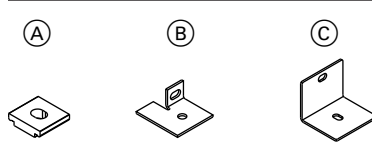

- (A) Vitosol-FM/-F, for vertical and horizontal installation
- (B) Vitosol-TM, for vertical installation
- (C) Vitosol-TM, for horizontal installation

Design information regarding flat roof installation

11.1 Calculating collector row clearance "z"

At sunrise and sunset (when the sun is very low), shading cannot be avoided when collectors are arranged behind one another. To keep the reduction in yield within acceptable parameters, observe specific row spacing (dimension z) in accordance with VDI Guideline 6002-1. When the sun is at its highest on the shortest day of the year (21/12), the rows at the back should be free of shading. The angle of the sun β (at midday) on 21/12 must be used to calculate the row spacing. In Germany, this angle lies between 11.5° (Flensburg) and 19.5° (Constance), depending on latitude.

Example with Vitosol-FM/-F, type SH

$h = 1056 \text{ mm}$
 $\alpha = 45^\circ$
 $\beta = 16.5^\circ$

$$z = \frac{h \cdot \sin(180^\circ - (\alpha + \beta))}{\sin \beta}$$

$$z = \frac{1056 \text{ mm} \cdot \sin(180^\circ - 61.5^\circ)}{\sin 16.5^\circ}$$

$z = 3268 \text{ mm}$

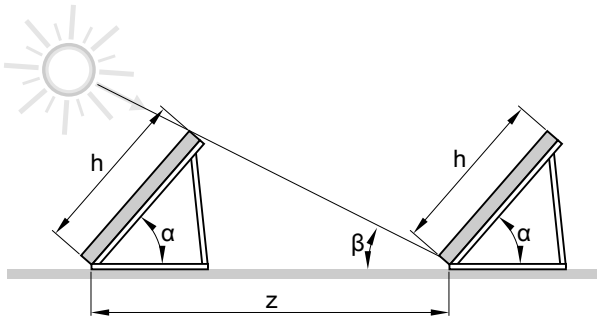

$$\frac{z}{h} = \frac{\sin(180^\circ - (\alpha + \beta))}{\sin \beta}$$

- z = Collector row spacing
- h = Collector height (for dimensions see chapter "Specification" for the relevant collector)
- α = Angle of collector inclination
- β = Angle of the sun

Example:

Würzburg is approximately located on latitude 50° north. In the northern hemisphere, this value is deducted from a fixed angle of 66.5°:

Angle $\beta = 66.5^\circ - 50^\circ = 16.5^\circ$

α	Collector row clearance z in mm			
	Vitosol-FM/-F		Vitosol 300-TM, type SP3C	Vitosol 200-TM, type SPEA
	Type SV	Type SH		
Flensburg				
25°	6890	3060	6686	—
30°	7630	5715	7448	7511
35°	8370	3720	8154	—
45°	9600	4260	9373	9453
50°	10100	4490	9878	—
60°	10890	4830	10660	10750
Kassel				
25°	5830	2590	5446	—
30°	6385	2845	5981	6032
35°	6940	3100	6471	—
45°	7840	3480	7299	7360
50°	8190	3640	7631	—
60°	8720	3870	8119	8187
Munich				
25°	5160	2290	4862	—
30°	5595	2485	5290	5772
35°	6030	2680	5677	—
45°	6710	2980	6321	6993
50°	6980	3100	6571	—
60°	7350	3260	6921	7737

11.2 Vitosol-FM/-F flat-plate collectors (on collector supports)

Observe the information on securing collectors on page 103.

Viessmann offers 2 collector supports for fixing the collectors:

- With a **variable angle of inclination** (snow loads up to 2.55 kN/m², wind speeds up to 150 km/h):
The collector supports are pre-assembled. They consist of the base rail, collector support and adjustable support with holes for adjusting the angle of inclination (see the following chapter).
- With **fixed angles of inclination** of 30°, 45° and 60° (snow loads up to 1.5 kN/m², wind speeds up to 150 km/h):
Collector supports with footplates (see page 118 onwards).
For this version the angle of inclination is calculated from the distance between the footplates.

Cross braces are required for 1 to 6 collectors connected side by side to secure the support.

Collector supports with variable angle of inclination

Type SV — angle of inclination α 25 to 60°

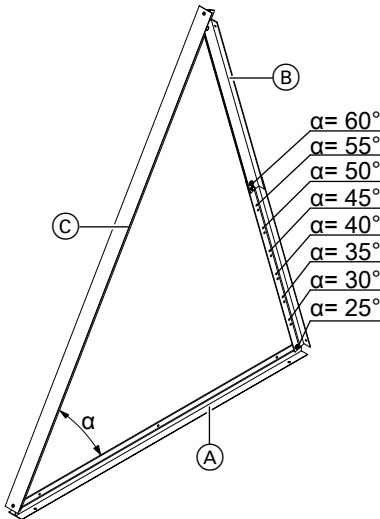

- (A) Base rail
- (B) Adjustable support
- (C) Collector support

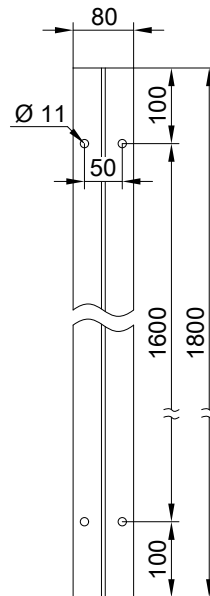

Base rail hole dimensions

Design information regarding flat roof installation (cont.)

Type SH — angle of inclination α 25 to 45°

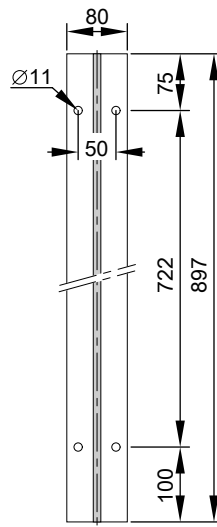
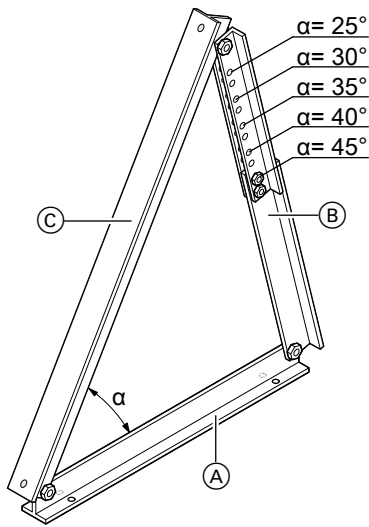

- (A) Base rail
- (B) Adjustable support
- (C) Collector support

Base rail hole dimensions

Type SH — angle of inclination α 50 to 80°

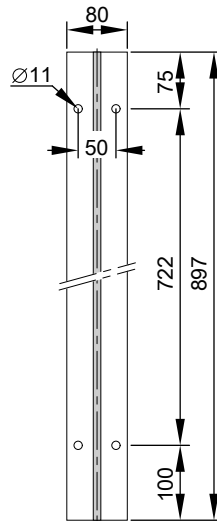
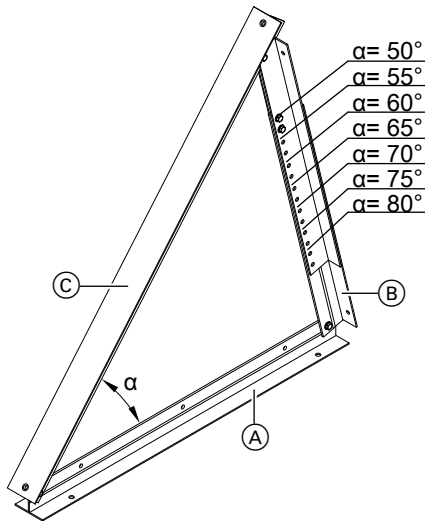

- (A) Base rail
- (B) Adjustable support
- (C) Collector support

Base rail hole dimensions

Design information regarding flat roof installation (cont.)

Type SV and SH — installation on an on-site substructure, e.g. steel beams

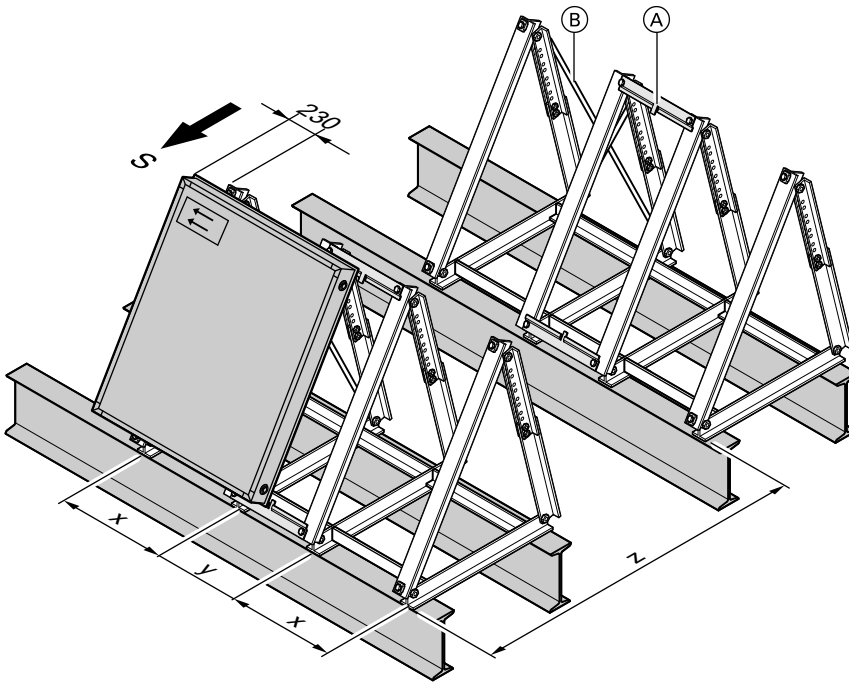

- Ⓐ Joining plate
- Ⓑ Cross brace

Type	SV	SH
x in mm	595	1920
y in mm	481	481
z in mm	See page 114.	See page 114.

Design information regarding flat roof installation (cont.)

Type SV and SH — installation on concrete slabs

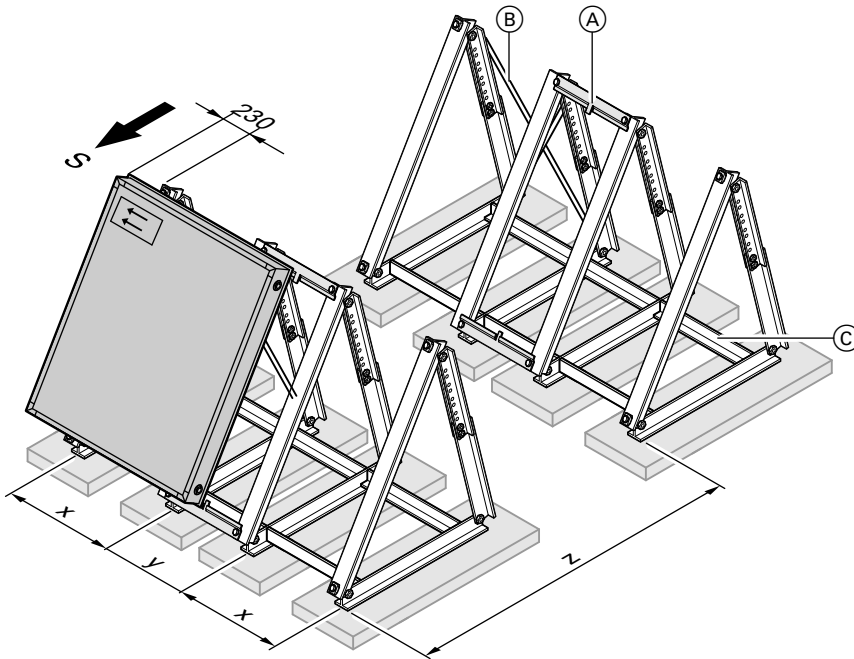

- (A) Joining plate
- (B) Cross brace
- (C) Support rail (only on roofs with gravel ballast layer)

Type	SV	SH
x in mm	595	1920
y in mm	481	481
z in mm	See page 114.	See page 114.

Collector supports with fixed angle of inclination

Type SV and SH

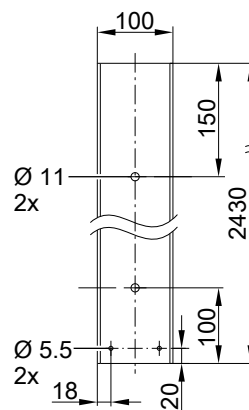
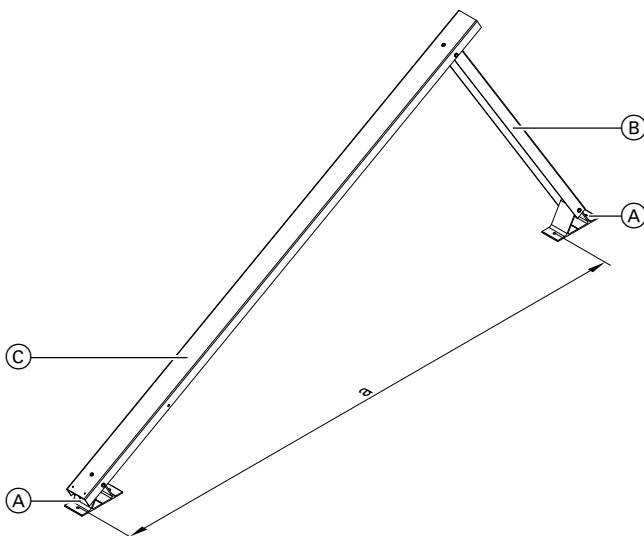

Type	SV	SH	
a	mm	2580	1000

- (A) Footplates
- (B) Adjustable support
- (C) Collector support

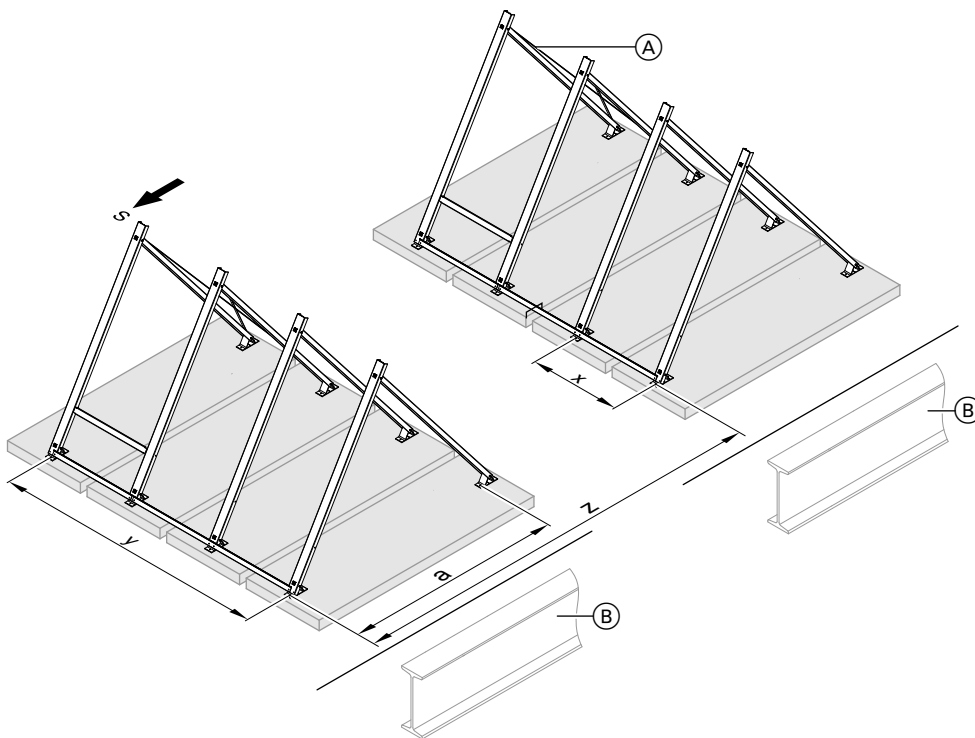

Example: Fixing for 3 collectors

- Ⓐ Cross brace
- Ⓑ On-site substructure, e.g. steel beams (on site)

Type	SV	SH
x in mm	1080	2400
z in mm	See page 114.	See page 114.

Number of collectors	y in mm	
	Type SV	Type SH
1	1080	2400
2	2155	4805
3	3235	7205
4	4310	9610
5	5390	12010
6	6470	14410
7	7545	16815
8	8625	19215
9	9700	21620
10	10780	24020
11	11860	26420
12	12935	28825
13	14015	31225
14	15090	33630
15	16170	36030

11.3 Vacuum tube collectors (on collector supports)

Observe the information on securing collectors on page 103.

Design information regarding flat roof installation (cont.)

Viessmann offers 2 collector supports for fixing the collectors:

- With a **variable angle of inclination** of 25 to 50° (snow loads up to 2.55 kN/m², wind speeds up to 150 km/h):

The collector supports are pre-assembled. They consist of the base rail, collector support and adjustable support with holes for adjusting the angle of inclination (see the following chapter).

- With a **fixed angle of inclination** (snow loads up to 1.5 kN/m², wind speeds up to 150 km/h):

Collector supports with mounting feet (see page 121 onwards). For this version the angle of inclination is calculated from the distance between the mounting feet.

Cross braces are required for 1 to 6 collectors connected side by side to secure the support.

Collector supports with variable angle of inclination

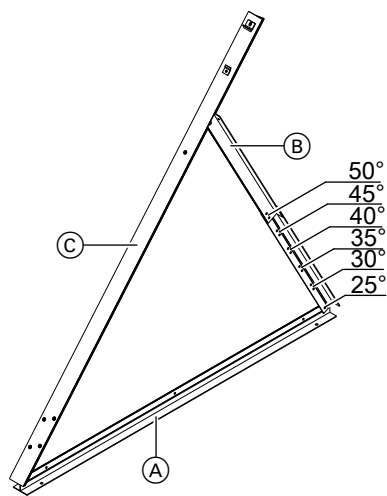

- (A) Base rail
- (B) Adjustable support
- (C) Collector support

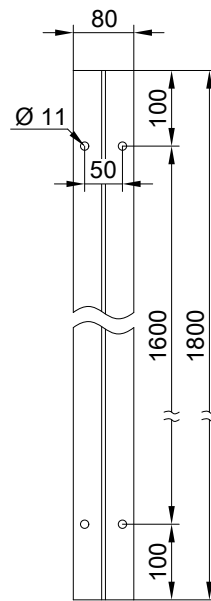

Base rail hole dimensions

Design information regarding flat roof installation (cont.)

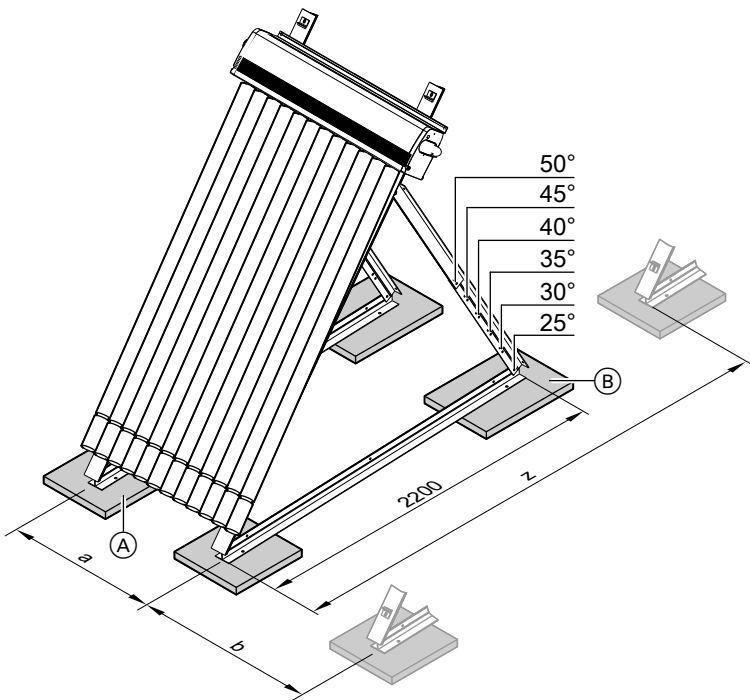

For calculating distance "z" between collector rows, see page 114.

- (A) Support slab A
- (B) Support slab B

Vitosol 300-TM, type SP3C

Combination	a	mm	b	mm
1.51 m ² /1.51 m ²		505/505		595
1.51 m ² /3.03 m ²		505/1010		850
3.03 m ² /3.03 m ²		1010/1010		1100

Collector supports with fixed angle of inclination

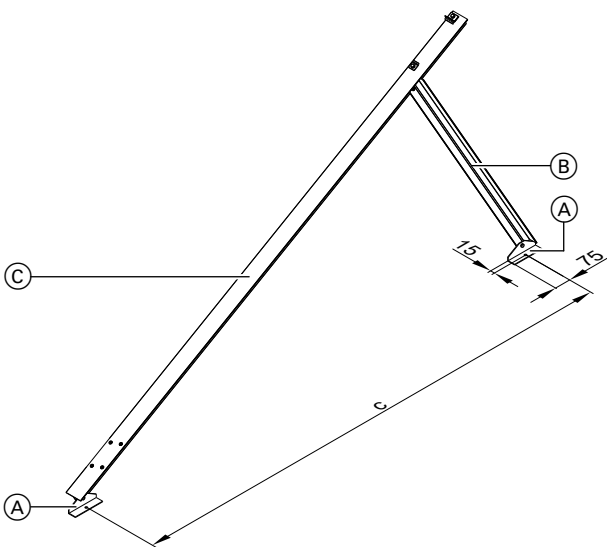

- (A) Mounting feet
- (B) Adjustable support
- (C) Collector support

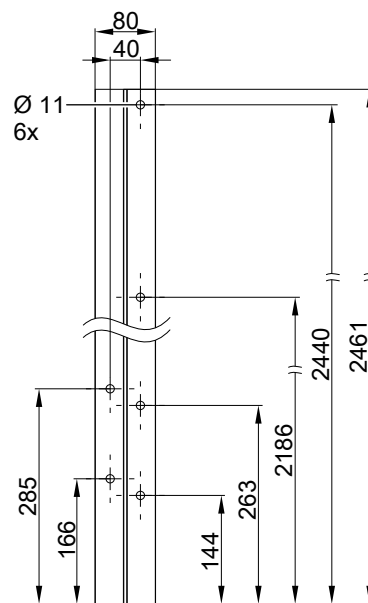

Angle of inclination	30°	45°	60°
c in mm	2413	2200	1838

5822440

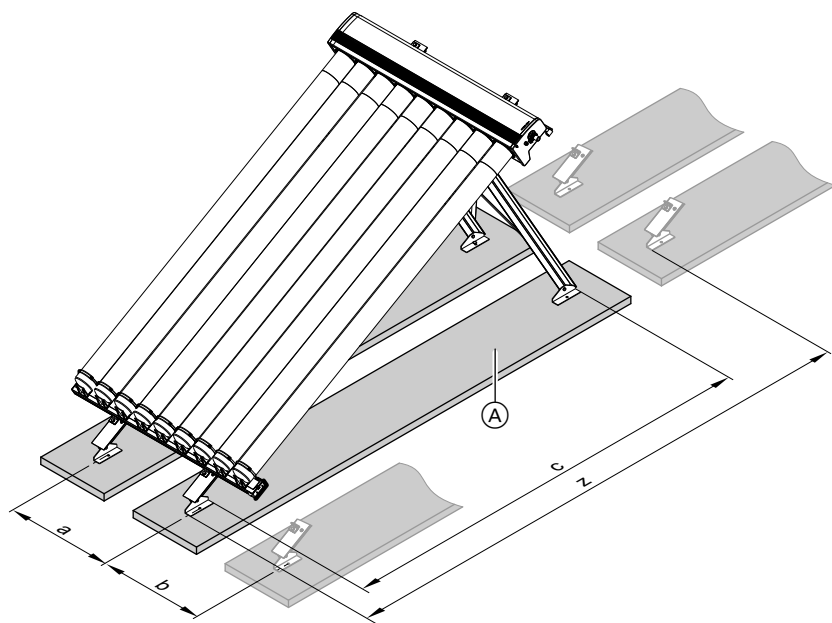

For calculating distance "z" between collector rows, see page 114.

Ⓐ Support slabs

Vitosol 200-TM, type SPEA

Combination	a	mm	b	mm
1.63 m ² /1.63 m ²		600/600		655
1.63 m ² /3.26 m ²		600/1200		947
3.26 m ² /3.26 m ²		1200/1200		1231

Vitosol 300-TM, type SP3C

Combination	a	mm	b	mm
1.51 m ² /1.51 m ²		505/505		595
1.51 m ² /3.03 m ²		505/1010		850
3.03 m ² /3.03 m ²		1010/1010		1100

11.4 Vitosol 200-TM vacuum tube collectors, type SPEA and Vitosol 300-TM, type SP3BC (horizontal)

Observe the information on securing collectors on page 102.

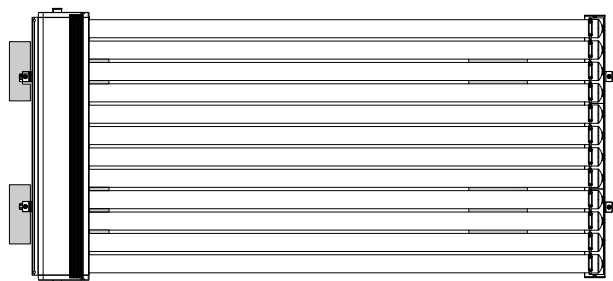
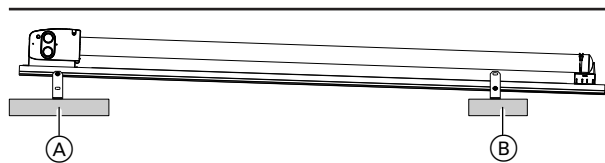

Vitosol 300-TM, type SP3C

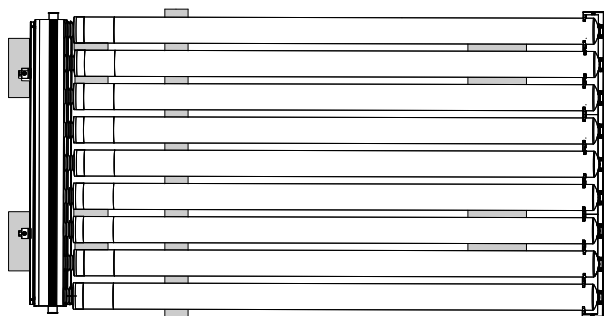
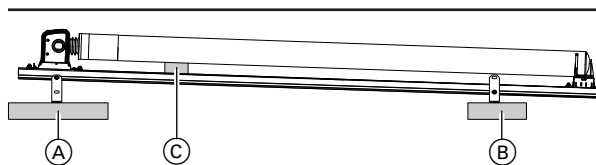

Vitosol 200-TM, type SPEA

Ⓐ Support slab A
Ⓑ Support slab B

Ⓐ Support slab A
Ⓑ Support slab B
Ⓒ Auxiliary rail for high snow loads

Type SP3C

Horizontal installation for snow loads up to 1.5 kN/m² and wind loads up to 150 km/h

■ The yield can be optimised by rotating the vacuum tubes 25° to the horizontal.

Design information regarding flat roof installation (cont.)

Type SPEA

Horizontal installation for snow loads up to 0.75 kN/m² and wind loads up to 150 km/h.

For snow loads up to 1.5 kN/m² with auxiliary rail (C)

- The yield can be optimised by rotating the vacuum tubes 45° to the horizontal.

Design information for installation on walls

12.1 Vitosol-FM/-F flat-plate collectors, type SH

Observe the information on securing collectors on page 102.

The collector supports are pre-assembled. They consist of a base rail, a collector support and adjustable supports. The adjustable supports contain holes for adjusting the angle of inclination.

The fixing materials, e.g. screws, are to be provided on site.

Collector supports – angle γ 10 to 45°

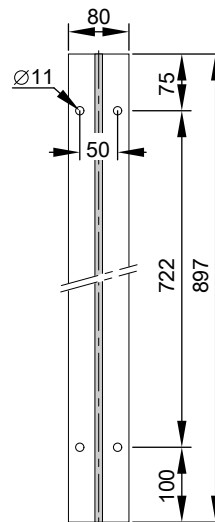
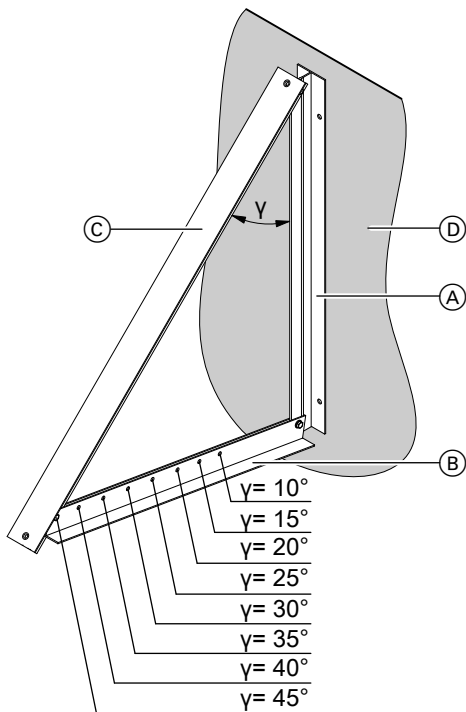

Base rail hole dimensions

- (A) Base rail
- (B) Adjustable support
- (C) Collector support
- (D) Wall

12.2 Vitosol 300-TM vacuum tube collectors, type SP3C

Observe the information on securing collectors on page 103.

- 3 collector sizes are available for installation on walls: 1.26 m², 1.51 m², 3.03 m²
- For installation on balconies, a special balcony module sized 1.26 m² is available.

Design information for installation on walls (cont.)

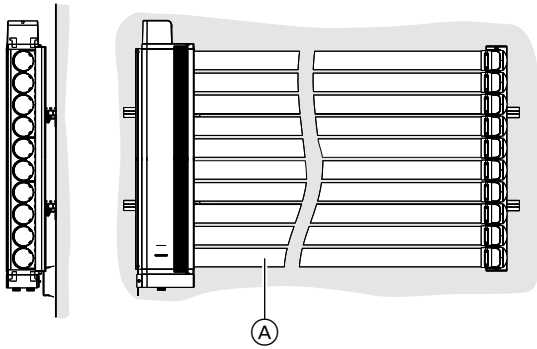

(A) Wall or balcony

Note

Diagrams with the required installation angles can be found in the installation instructions.

The yield can be optimised by rotating the individual tubes by 25°. Establish the hydraulic connection from below.

Information regarding design and operation

13.1 Sizing the solar thermal system

All sizing recommended below relates to German climatic conditions and common utilisation profiles in the home. These profiles are stored in the Viessmann "Solcalc Thermie" calculation program and correspond to the suggestions of VDI 6002-1 for apartment buildings.

Under these prerequisites, a design output of 600 W/m² is assumed for all heat exchangers. The maximum yield of a solar thermal system is assumed to be approx. 4 kWh/(m²d). This value fluctuates depending on the product and location. To enable this heat yield to be transferred to the cylinder system, a ratio of approx. 50 l cylinder volume per m² aperture area is determined for all conventional designs. This ratio may change in relation to the system (subject to solar coverage and utilisation profiles). In such cases, a system simulation is unavoidable.

Irrespective of the capacity, in relation to the transferable output, only a limited number of collectors can be connected to the various DHW cylinders.

The transfer rate of the internal indirect coils depends on the temperature differential between the collector and cylinder temperatures.

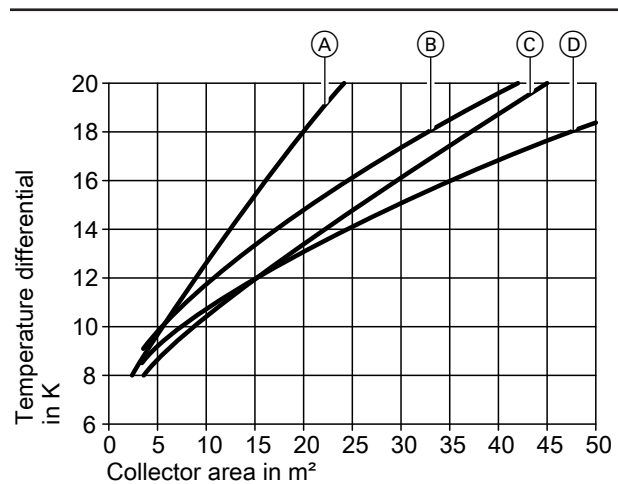

Flow rate 25 l/(h·m²)

- (A) Vitocell 100-B, 300 l
Indirect coil surface area 1.5 m²
- (B) Vitocell-M/Vitocell-E, 750 l
Indirect coil surface area 1.8 m²
- (C) Vitocell 100-B, 500 l
Indirect coil surface area 1.9 m²
- (D) Vitocell-M/Vitocell-E, 950 l
Indirect coil surface area 2.1 m²

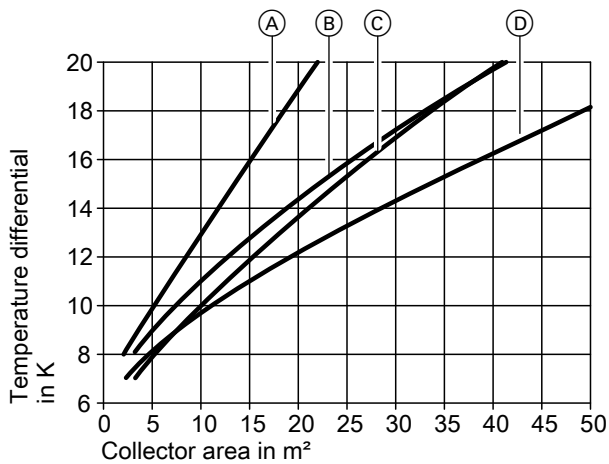

Flow rate 40 l/(hm²)

- (A) Vitocell 100-B, 300 l
Indirect coil surface area 1.5 m²
- (B) Vitocell-M/Vitocell-E, 750 l
Indirect coil surface area 1.8 m²
- (C) Vitocell 100-B, 500 l
Indirect coil surface area 1.9 m²
- (D) Vitocell-M/Vitocell-E, 950 l
Indirect coil surface area 2.1 m²

System for heating DHW

DHW heating in detached houses can be realised either with one dual mode DHW cylinder or with two mono mode DHW cylinders (for retrofitting an existing system).

Examples

For further detailed examples, see the "System examples" manual.

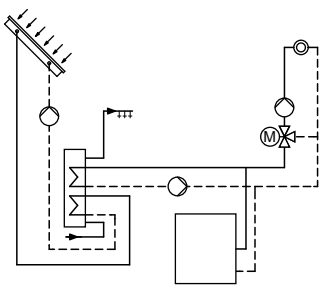

System with a dual mode DHW cylinder

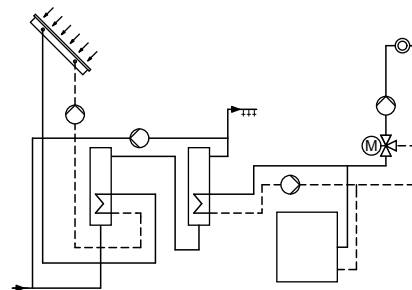

System with 2 mono mode DHW cylinders

The basis for sizing a solar thermal system for DHW heating is the DHW demand.

Viessmann packs are sized for solar coverage of approx. 60 %. The cylinder capacity must be greater than the daily DHW demand, taking the required DHW temperature into account.

To achieve solar coverage of approx. 60 %, the collector system must be sized so that the entire cylinder capacity can be heated on a single sunny day (5 hours of full sunshine) to at least 60 °C. This would allow for a subsequent day with poor insolation to be bridged.

Information regarding design and operation (cont.)

Occupants	Daily DHW demand in l (60 °C)	Cylinder capacity in l		Collector	
		Dual mode	Mono mode	Number Vitosol-FM/-F SV/SH	Surface area Vitosol-TM
2	60	250/300	160	2	1 x 3.03 m ²
3	90				
4	120				
5	150	300/400	200	3	1 x 3.03 m ²
6	180				
8	240	500	300	4	2 x 3.03 m ²
10	300				
12	360				
15	450				
			500	5	2 x 3.03 m ²
				6	1 x 1.51 m ²
					3 x 3.03 m ²

The details in the table apply under the following conditions:

- SW, S or SE orientation
- Roof pitches from 25 to 55°

System for DHW heating and central heating backup

Systems for central heating backup can be designed with very simple hydraulic connections by using a heating water buffer cylinder with integral DHW heating, e.g. Vitocell 340-M or Vitocell 360-M. A Vitocell 140-E or 160-E heating water buffer cylinder, combined with a dual mode DHW cylinder or Vitotrans 353, can be used as an alternative. The Vitotrans 353 generates DHW in accordance with the instantaneous water heater principle, enabling high draw-off rates to be achieved. Static DHW volumes are reduced to a minimum.

The stratification system inside the Vitocell 360-M and Vitocell 160-E optimises the heating of the buffer cylinder. The water inside the buffer cylinder that is heated by solar energy is channelled by a heating lance directly into the upper area of the buffer cylinder. Consequently, DHW is made available more rapidly.

Examples

For further detailed examples, see the "System examples" manual.

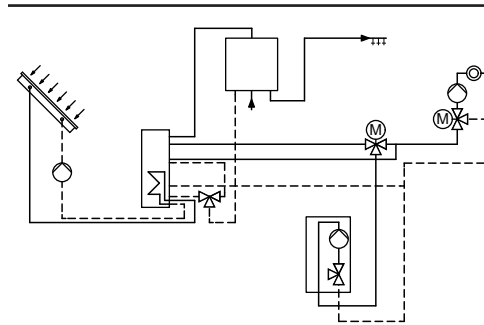

System with Vitocell-E heating water buffer cylinder and Vitotrans 353

For sizing a system for DHW heating and central heating backup, the seasonal efficiency of the entire heating system must be taken into consideration. The summer heat demand is always decisive. This is a combination of the heat demand for DHW heating and other project-specific consumers. The collector area must be sized for this demand. The calculated collector area is multiplied by a factor of 2 to 2.5. The result is the range within which the collector area should be for solar central heating backup. The precise determination is then made taking into consideration the building conditions and the design of an operationally reliable collector array.

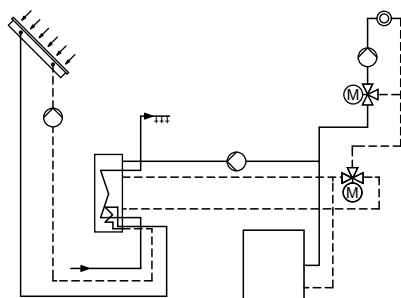

System with Vitocell-M heating water buffer cylinder

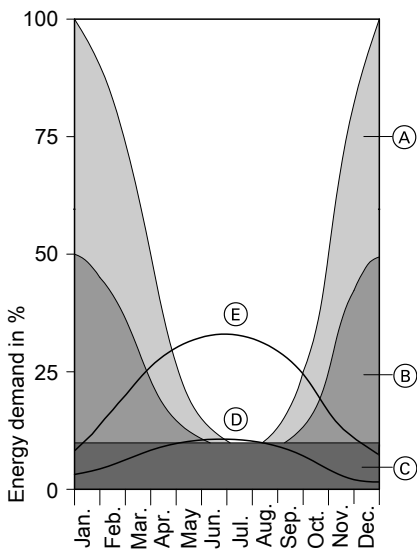

- (A) Central heating demand for a house (built in approx. 1984 or later)
- (B) Central heating demand for a low energy house
- (C) DHW demand
- (D) Solar yield at 5 m² absorber area
- (E) Solar yield at 15 m² absorber area

Occupants	Daily DHW demand in l (60 °C)	Buffer cylinder capacity in l	Collector	
			No. of Vitosol-FM/F	Vitosol-TM area
2	60	750	4 x SV 4 x SH	2 x 3.03 m ²
3	90			
4	120			
5	150	750/950	4 x SV 4 x SH	2 x 3.03 m ² 1 x 1.51 m ²
6	180			
7	210	950	6 x SV 6 x SH	3 x 3.03 m ²
8	240			

For low energy houses (heat demand less than 50 kWh/(m²·p.a.)), solar coverage of up to 35 %, relative to the total energy demand, incl. DHW heating, can be achieved according to this sizing. For buildings with a higher heat demand, the coverage is lower.

The Viessmann "SolCalc Thermie" calculation program can be used for the exact calculation.

Swimming pool heating system – heat exchanger and collector

Outdoor pools

In central Europe, outdoor pools are used between May and September. Your energy consumption depends primarily on the leakage rate, evaporation, loss (water must be replenished cold) and transmission heat loss. By using a cover, the evaporation and consequently the energy demand of the pool can be reduced to a minimum. The largest energy input comes directly from the sun, which shines onto the pool surface. Therefore the pool has a "natural" base temperature that can be shown in the following diagram as an average pool temperature over the operating time.

A solar thermal system does not alter this typical temperature pattern. The solar application leads to a definite increase in the base temperature. Subject to the ratio between the pool surface and the absorber area, a different temperature increase can be reached.

Information regarding design and operation (cont.)

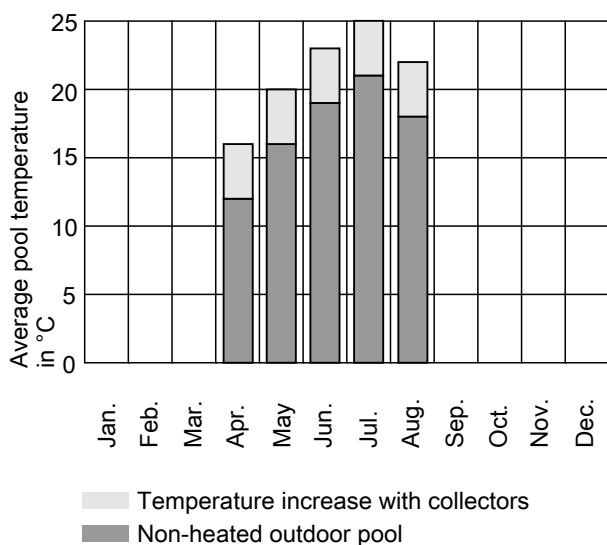

Typical temperature curve of an outdoor pool (average monthly values)

Location: Würzburg
 Pool surface area: 40 m²
 Depth: 1.5 m
 Position: Sheltered and covered at night

The following diagram shows the average temperature increase that can be achieved with various ratios of absorber area to pool surface area. This ratio is independent of the collector type used due to the comparably low collector temperatures and the operating period (summer).

Note

Heating and maintaining the pool temperature at a higher set temperature using a conventional heating system does not alter this ratio. However, the pool will be heated up much more quickly.

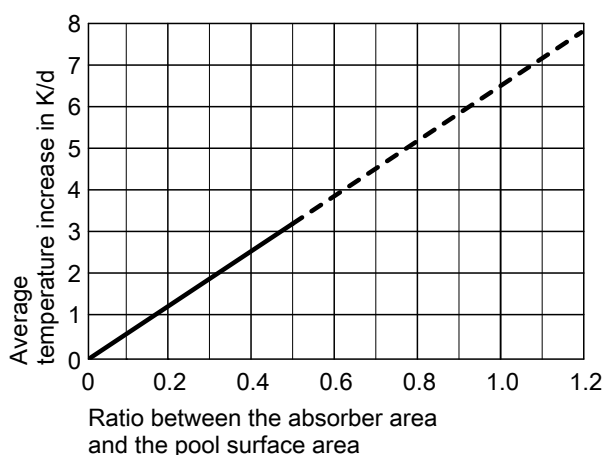

Indoor pools

Indoor pools have a higher target temperature than outdoor pools and are used throughout the year. If, over the course of the year, a constant pool temperature is required, indoor pools must be heated in dual mode. To avoid sizing errors, the energy demand of the pool must be measured. For this, suspend reheating for 48 hours and determine the temperature at the beginning and end of the test period. The daily energy demand can therefore be calculated from the temperature differential and the content of the pool. For new projects, the heat demand of the swimming pool must be calculated. On a summer's day (clear skies), a collector system used to heat a swimming pool in central Europe produces energy of approx. 4.5 kWh/m² absorber area.

Calculation example for Vitosol 200-FM/-F

Pool surface area: 36 m²
 Average pool depth: 1.5 m
 Pool capacity: 54 m³
 Temperature loss over 2 days: 2 K
 Daily energy demand: 54 m³ · 1 K · 1.16 (kWh/K · m³) = 62.6 kWh
 Collector area: 62.6 kWh : 4.5 kWh/m² = 13.9 m²

This corresponds to 6 collectors.

For a first approximation (cost estimate), an average temperature loss of 1 K/day can be used. With an average pool depth of 1.5 m, an energy demand of approx. 1.74 kWh/(d · m² pool surface area) is required to maintain the set temperature. It is therefore sensible to use an absorber area of approx. 0.4 m² per m² of pool surface area. Under the following conditions, never exceed the max. absorber area stated in the table:

- Design output of 600 W/m²
- Max. temperature differential between the swimming pool water (heat exchanger flow) and the solar circuit return 10 K

Vitotrans 200, type WTT	Part no.	3003453	3003454	3003455	3003456	3003457
Max. connectable absorber area Vitosol	m ²	28	42	70	116	163

13.2 Solar thermal system operating modes

Flow rate in the collector array

Collector systems can be operated with different specific flow rates. The unit for this is the flow rate in $l/(hm^2)$. The reference variable is the absorber area. At the same collector output, a higher flow rate means a lower temperature spread in the collector circuit; a lower flow rate means a higher temperature spread. With a high temperature spread, the average collector temperature increases, i.e. the efficiency of the collectors drops. On the other hand, where the flow rates are lower, less energy is required to operate the pumps and the pipework sizing can be smaller.

Operating modes:

- **Low flow operation**
Operation with flow rates up to approx. $30 l/(hm^2)$
- **High flow operation**
Operation with flow rates greater than $30 l/(hm^2)$
- **Matched flow operation**
Operation with variable flow rates

All operating modes are possible with Viessmann collectors.

Which operating mode is the right one?

The specific flow rate must be high enough to ensure a reliable and even flow through the entire array. The optimum flow rate (relative to the current cylinder temperatures and the current insolation level) in systems with a Viessmann solar control unit will adjust itself automatically in matched flow operation. Single array systems with Vitosol-FM/-F or Vitosol-T can be operated without problems down to approx. 50 % of the specific flow rate.

Required flow rate: $25 l/(hm^2)$

This results in the following: 115 l/h, i.e. approx. 1.9 l/min. This value should be reached at 100 % pump rate. Adjustment is made via the solar control unit. The solar control unit reduces the flow rate after start up to a set minimum and, with increasing temperature differential to the consumer, incrementally increases the speed via a PWM signal. This aims to achieve as continuous a pump operation as possible.

Example:

4.6 m² absorber area

13.3 Installation examples Vitosol-FM/-F, types SV and SH

Take ventilation into consideration when designing the collector arrays (see chapter "Ventilation" on page 139).

High flow operation — single sided connection

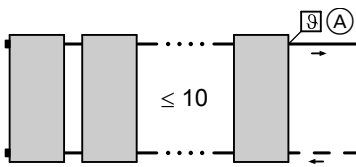

(A) Collector temperature sensor in the flow

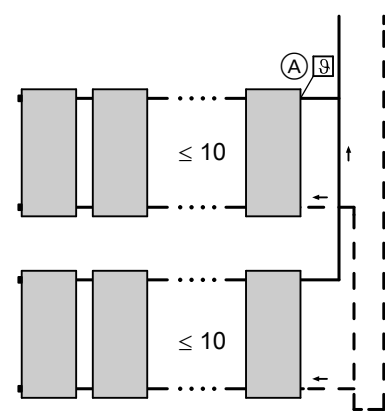

(A) Collector temperature sensor in the flow

High flow operation — connection on alternate sides

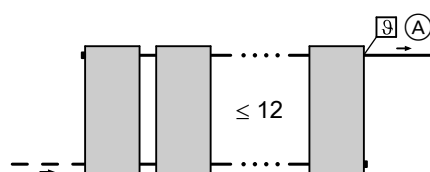

(A) Collector temperature sensor in the flow

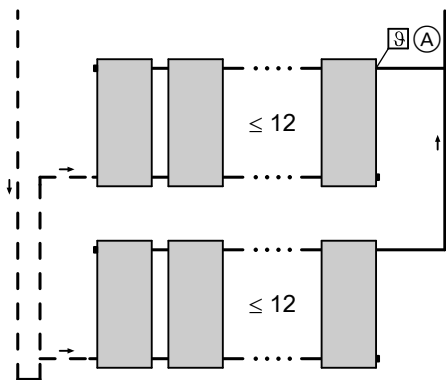

(A) Collector temperature sensor in the flow

Low flow operation — single sided connection

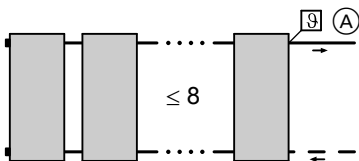

(A) Collector temperature sensor in the flow

Low flow operation — connection on alternate sides

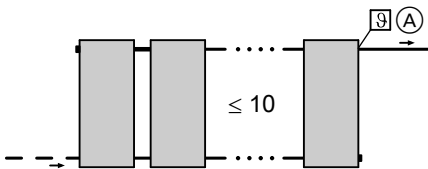

(A) Collector temperature sensor in the flow

13.4 Installation examples Vitosol 200-TM, type SPEA

Take ventilation into consideration when designing the collector arrays (see chapter "Ventilation" on page 139).

Note

Max. 16.3 m² absorber area can be connected in series to form a single array.

Vertical installation on pitched roofs, installation on collector supports or horizontal installation

Single row installation; connection from the left or right

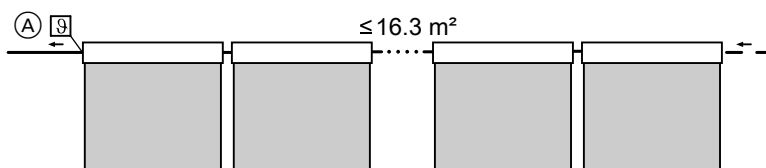

(A) Collector temperature sensor

Information regarding design and operation (cont.)

Installation in several rows; connection from the left or right

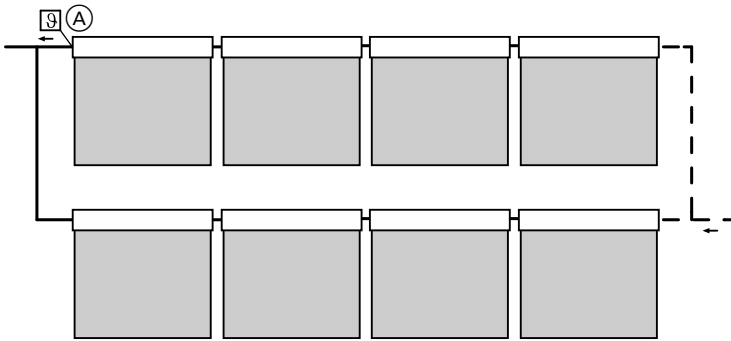

(A) Collector temperature sensor

Horizontal installation on a pitched roof

1 collector array

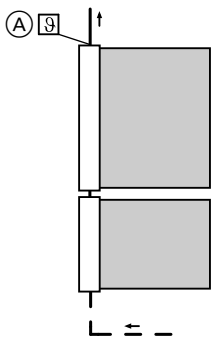

(A) Collector temperature sensor

For this type of installation, ensure the following minimum flow rates in the collector array (section):

4 m ²	35 l/(hm ²)
5 m ²	30 l/(hm ²)
≥6 m ²	25 l/(hm ²)
3 m ²	45 l/(hm ²)
< 2 m ²	65 l/(hm ²)

2 or more collector arrays (≥ 4 m²)

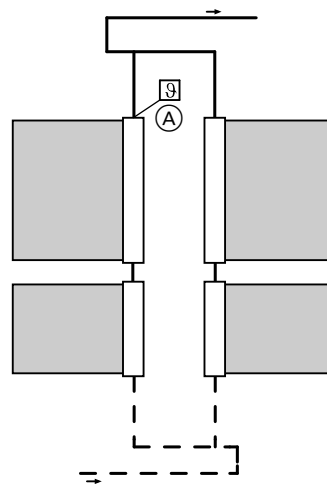

With this type of connection, the "interval function" on the control unit must be enabled.

(A) Collector temperature sensor

13.5 Installation examples Vitosol 300-TM, type SP3C

Take ventilation into consideration when designing the collector arrays (see chapter "Ventilation" on page 139).

Information regarding design and operation (cont.)

Note

Max. 15 m² absorber area can be connected in series to form a single array.

Vertical installation on pitched roofs, installation on collector supports or horizontal installation

Connection from the left

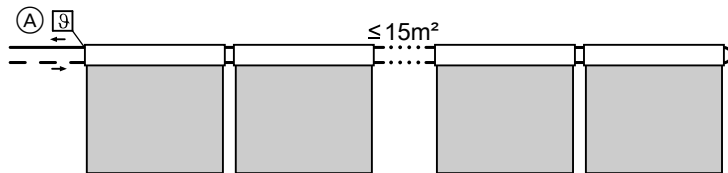

(A) Collector temperature sensor in the flow

Connection from the right

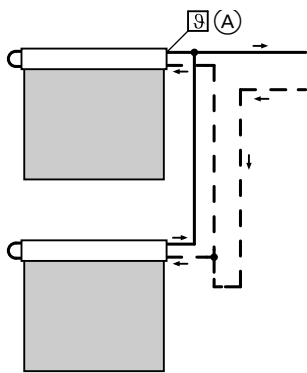

(A) Collector temperature sensor in the flow

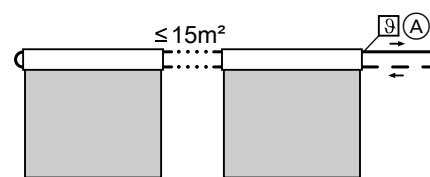

(A) Collector temperature sensor in the flow

Horizontal installation on pitched roofs and on walls

Single sided connection from below (preferred version)

1 collector array

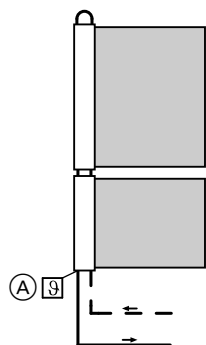

With this type of connection, the "interval function" on the control unit must be enabled.

(A) Collector temperature sensor in the flow

With this installation, the following minimum flow rates in the collector array (section) must be ensured:

1.26 m ²	110 l/(hm ²)
1.51 m ²	90 l/(hm ²)
3.03 m ²	45 l/(hm ²)
4.54 m ²	30 l/(hm ²)
≥6.06 m ²	25 l/(hm ²)

2 or more collector arrays ($\geq 4 \text{ m}^2$)

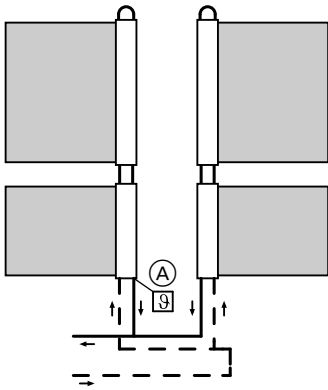

With this type of connection, the "interval function" on the control unit must be enabled.

(A) Collector temperature sensor in the flow

13.6 Pressure drop of the solar thermal system

- The specific flow rate for the collectors is determined by the type of collector and the intended method of operation of the collector array. The way the collectors are linked determines the pressure drop of the collector array.
- The overall flow rate for the solar thermal system results from multiplying the specific flow rate by the absorber area. The pipework dimensions are determined assuming a required flow velocity of between 0.4 and 0.7 m/s (see page 136).
- Once the pipework dimensions have been determined, the pressure drop for the pipework (in mbar/m) is then calculated.
- External heat exchangers must be calculated as well and should not exceed a pressure drop of 100 mbar/10 kP. For smooth tube internal indirect coils, the pressure drop is much lower and can be ignored in solar thermal systems with a collector area of up to 20 m².
- The pressure drop of further solar circuit components can be found in the relevant technical documentation. Include the pressure drop of further solar circuit components in the overall calculation.
- When calculating the pressure drop, take into account the fact that the heat transfer medium has a different viscosity to pure water. The hydraulic characteristics become more similar as the temperature of the media increases. At low temperatures around freezing, the high viscosity of the heat transfer medium may result in a pump rate some 50 % higher than for pure water. With a medium temperature above approx. 50 °C (controlled operation of solar thermal systems), the difference in viscosity is only minor.

Pressure drop of the solar flow and return lines

Per m pipe length, corrugated stainless steel pipe DN16, relative to water, corresponds to Tyfocor LS at approx. 60 °C

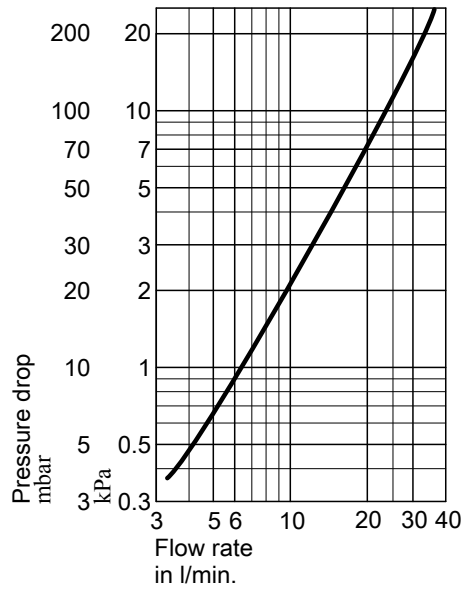

Pressure drop Vitosol-FM/-F, types SV and SH

Relative to water, corresponds to Tyfocor LS at approx. 60 °C

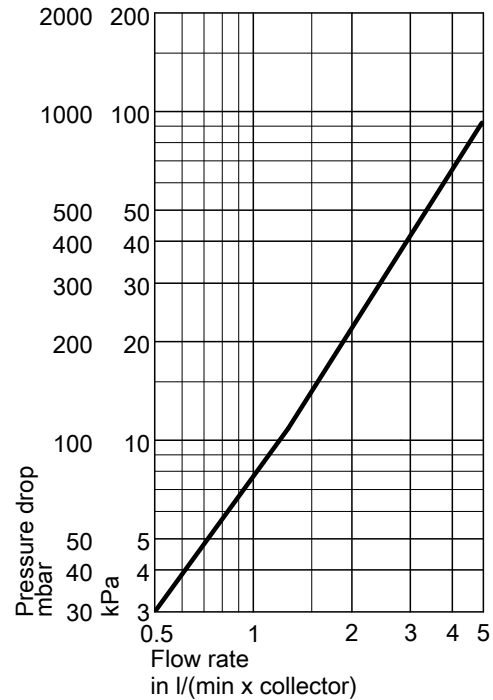

13

Pressure drop Vitosol 200-TM and Vitosol 300-TM

Relative to water, corresponds to Tyfocor LS at approx. 60 °C

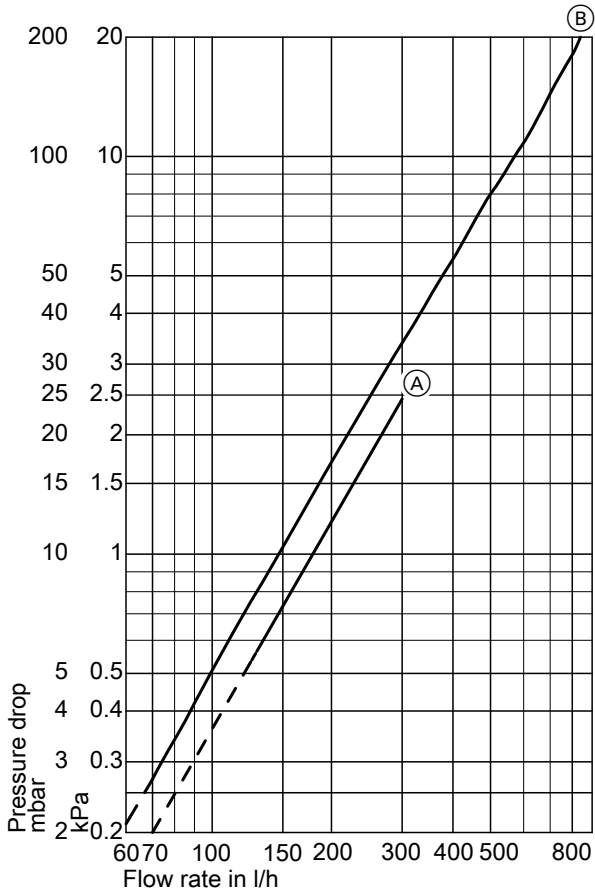

Pressure drop Vitosol 300-TM

- Ⓐ 1.26/1.51 m²
- Ⓑ 3.03 m²

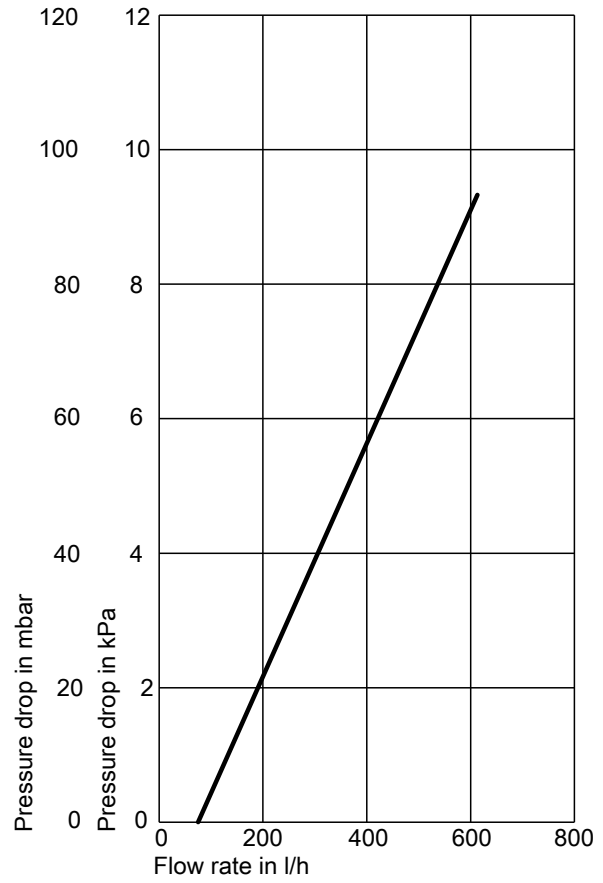

Pressure drop Vitosol 200-TM, 1.63 m²

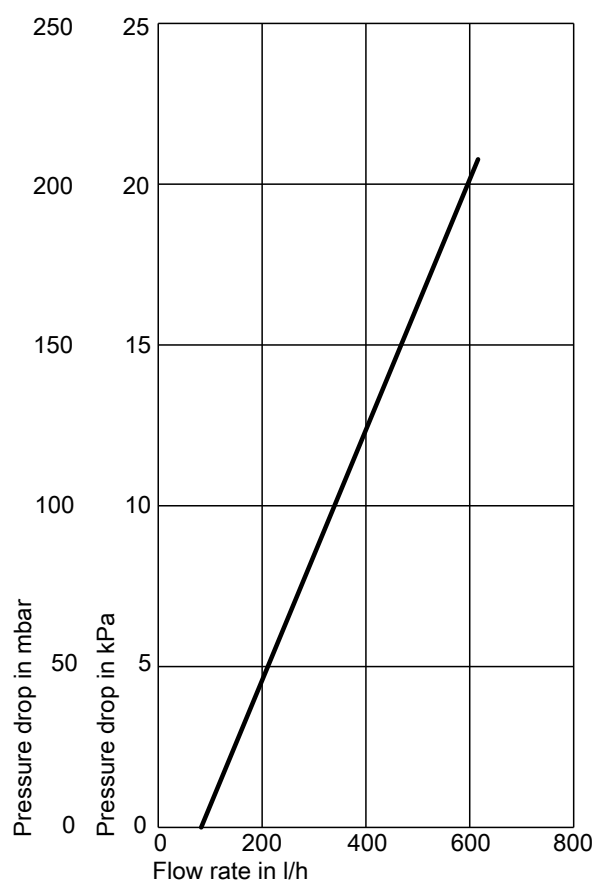

Pressure drop Vitosol 200-TM, 3.26 m²

13.7 Flow velocity and pressure drop

Flow velocity

To minimise the pressure drop through the solar thermal system pipework, the flow velocity in the copper pipe should not exceed 1 m/s. In accordance with VDI 6002-1 [or local regulations], we recommend flow velocities of between **0.4 and 0.7 m/s**. At these flow velocities, a pressure drop of between 1 and 2.5 mbar/m/0.1 and 0.25 kPa/m pipe length will result.

Note

A higher flow velocity results in a higher pressure drop. A substantially lower flow velocity will make ventilation more difficult.

The air that collects at the collector must be routed downwards through the solar flow line to the air vent valve. For the installation of collectors, we recommend sizing the pipes as for a standard heating system according to flow rate and flow velocity (see the following table).

Subject to the flow rate and pipe dimensions, different flow velocities result.

Information regarding design and operation (cont.)

Flow rate (total collector area)		Flow velocity in m/s						
		Pipe dimensions						
l/h	l/min	DN10	DN13	DN16	DN20	DN25	DN32	DN40
		Dimensions						
		12 x 1	15 x 1	18 x 1	22 x 1	28 x 1.5	35 x 1.5	42 x 1.5
125	2.08	0.44	—	—	—	—	—	—
150	2.50	0.53	0.31	—	—	—	—	—
175	2.92	0.62	0.37	0.24	—	—	—	—
200	3.33	0.70	0.42	0.28	0.18	—	—	—
250	4.17	0.88	0.52	0.35	0.22	—	—	—
300	5.00	1.05	0.63	0.41	0.27	—	—	—
350	5.83	—	0.73	0.48	0.31	—	0.11	—
400	6.67	—	0.84	0.55	0.35	0.23	0.13	0.09
450	7.50	—	0.94	0.62	0.40	0.25	0.14	0.10
500	8.33	—	—	0.69	0.44	0.28	0.16	0.12
600	10.00	—	—	0.83	0.53	0.34	0.19	0.14
700	11.67	—	—	0.97	0.62	0.40	0.22	0.16
800	13.33	—	—	—	0.71	0.45	0.25	0.19
900	15.00	—	—	—	0.80	0.51	0.28	0.21
1000	16.67	—	—	—	—	0.57	0.31	0.23
1500	25.00	—	—	—	—	0.85	0.47	0.35
2000	33.33	—	—	—	—	1.13	0.63	0.46
2500	41.67	—	—	—	—	—	0.79	0.58
3000	50.00	—	—	—	—	—	0.94	0.70

Recommended pipe dimensions

Pressure drop of the pipework

For water/glycol mixtures at temperatures higher than 50 °C.

Flow rate (total collector area)		Pressure drop per m pipe length (including valves) in mbar/m / kPa/m				
		Pipe dimensions				
l/h		DN10	DN13	DN16	DN20	DN25
		Dimensions				
		12 x 1	15 x 1	18 x 1	22 x 1	28 x 1.5
100		4.6/0.46				
125		6.8/0.68				
150		9.4/0.94				
175		12.2/1.22				
200		15.4/1.54	4.4/0.44			
225		18.4/1.84	5.4/0.54			
250		22.6/2.26	6.6/0.66	2.4/0.24		
275		26.8/2.68	7.3/0.73	2.8/0.28		
300			9.0/0.90	3.4/0.34		
325			10.4/1.04	3.8/0.38		
350			11.8/1.18	4.4/0.44		
375			13.2/1.32	5.0/0.50		
400			14.8/1.48	5.6/0.56	2.0/0.20	
425			16.4/1.64	6.2/0.62	2.2/0.22	
450			18.2/1.82	6.8/0.68	2.4/0.24	
475			20.0/2.00	7.4/0.74	2.6/0.26	
500			22.0/2.20	8.2/0.82	2.8/0.28	
525				8.8/0.88	3.0/0.30	
550				9.6/0.96	3.4/0.34	
575				10.4/1.04	3.6/0.36	
600				11.6/1.16	3.8/0.38	
625					4.2/0.42	
650					4.4/0.44	
675					4.8/0.48	
700					5.0/0.50	1.8/0.18
725					5.4/0.54	1.9/0.19
750					5.8/0.58	2.0/0.20
775					6.0/0.60	2.2/0.22
800					6.4/0.64	2.3/0.23
825					6.8/0.68	2.4/0.24

Information regarding design and operation (cont.)

Flow rate (total collector area)	Pressure drop per m pipe length (including valves) in mbar/m / kPa/m				
	Pipe dimensions				
	DN10	DN13	DN16	DN20	DN25
l/h	Dimensions				
	12 x 1	15 x 1	18 x 1	22 x 1	28 x 1.5
850				7.2/0.72	2.5/0.25
875				7.6/0.76	2.6/0.26
900				8.0/0.80	2.8/0.28
925				8.4/0.84	2.9/0.29
950				8.8/0.88	3.0/0.30
975				9.2/0.92	3.2/0.32
1000				9.6/0.96	3.4/0.34

Range between 0.4 and 0.7 m/s flow velocity

13.8 Sizing the circulation pump

If the flow rate and pressure drop of the entire solar thermal system are known, the pump can be selected on the basis of the pump curve.

Viessmann supplies the Solar-Divicon and a separate solar pump assembly to simplify the installation and the selection of pumps and safety equipment. For construction and specification see chapter "Installation accessories".

Note

The Solar-Divicon and the solar pump assembly are unsuitable for direct contact with swimming pool water.

Note

The following table does not apply to Vitosol 200-TM, type SPEA.

For this collector type, the solar circuit pump must be specially sized and provided on site.

Absorber area in m ²	Specific flow rate in l/(hm ²)						
	25	30	35	40	50	60	80
	Low flow operation	High flow operation					
	Flow rate in l/min						
2	0.83	1.00	1.17	1.33	1.67	2.00	2.67
3	1.25	1.50	1.75	2.00	2.50	3.00	4.00
4	1.67	2.00	2.33	2.67	3.33	4.00	5.33
5	2.08	2.50	2.92	3.33	4.17	5.00	6.67
6	2.50	3.00	3.50	4.00	5.00	6.00	8.00
7	2.92	3.50	4.08	4.67	5.83	7.00	9.33
8	3.33	4.00	4.67	5.33	6.67	8.00	10.67
9	3.75	4.50	5.25	6.00	7.50	9.00	12.00
10	4.17	5.00	5.83	6.67	8.33	10.00	13.33
12	5.00	6.60	7.00	8.00	10.00	12.00	16.00
14	5.83	7.00	8.17	9.33	11.67	14.00	18.67
16	6.67	8.00	9.33	10.67	13.33	16.00	21.33
18	7.50	9.00	10.50	12.00	15.00	18.00	24.00
20	8.33	10.00	11.67	13.33	16.67	20.00	26.67
25	10.42	12.50	14.58	16.67	20.83	25.00	33.33
30	12.50	15.00	17.50	20.00	25.00	30.00	—
35	14.58	17.50	20.42	23.33	29.17	35.00	—
40	16.67	20.00	23.33	26.67	33.33	—	—
50	20.83	25.00	29.17	33.33	—	—	—
60	25.00	30.00	35.00	—	—	—	—
70	29.17	35.00	—	—	—	—	—
80	33.33	—	—	—	—	—	—

Use of type PS10 or P10, with a residual head of 150 mbar/15 kPa (\approx 1.5 m)

Use of type PS20 or P20, with a residual head of 260 mbar/26 kPa (\approx 2.6 m)

Information regarding solar thermal systems with Vitosolic

Pumps with a power consumption of more than 190 W, in conjunction with a Vitosolic solar control unit, must be connected via an additional relay (on site).

13.9 Ventilation

At points in the system that are at high risk from steam or in roof installations, only use air separators with manual air vent valves, which require regular manual venting. This is particularly necessary after filling.

Correct ventilation of the solar circuit is a prerequisite for trouble-free and efficient operation of the solar thermal system. Air in the solar circuit generates noise and puts at risk the reliable flow through the collectors or through individual array sections. In addition it can lead to accelerated oxidation of organic heat transfer media (e.g. commercially available mixtures of water and glycol).

Air vent valves are used to vent air from the solar circuit:

- Manual air vent valve
- Automatic air vent valve
 - Quick-action air vent valve
 - Air separator

For the construction and specification of air vent valves, see chapter "Installation accessories".

The air vent valves are installed in the solar flow line at an accessible point in the installation room upstream of the heat exchanger inlet.

When setting up and connecting larger collector arrays, the ventilation characteristics of the system can be optimised by flow lines joined above the collectors. This prevents air bubbles from causing flow problems in individual collectors in partial arrays linked in parallel.

In systems higher than 25 m above the air vent valve, air bubbles that form in the collectors are dispersed again as a result of the high pressure increase. In such cases, we recommend using vacuum deaerator systems.

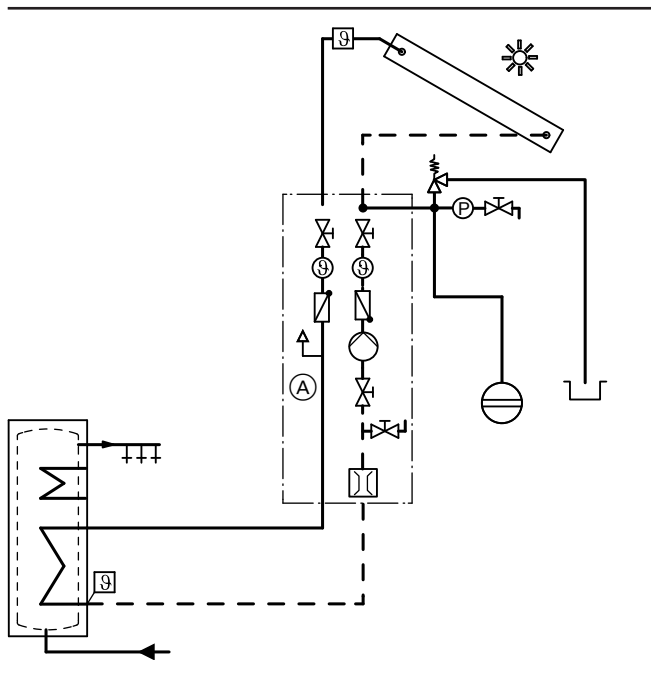

Ⓐ Air vent valve, built into Solar-Divicon

13.10 Safety equipment

Stagnation in solar thermal systems

All safety equipment in a solar thermal system must be designed for stagnation. If, during insolation on the collector array, heat can no longer be transferred within the system, the solar circuit pump stops and the solar thermal system goes into stagnation. Longer system idle times, e.g. due to faults or incorrect operation, can never be completely ruled out. This results in a rise in temperature up to the maximum collector temperature. Energy yield and loss are then the same.

Requirements:

- The solar thermal system must not be damaged by stagnation.
- The solar thermal system must not pose any risk during stagnation.
- Following stagnation, the solar thermal system must automatically return to operation.
- Collectors and pipework must be engineered for the temperatures expected during stagnation.

Pressure in solar thermal systems with Vitosol-FM and Vitosol 300-TM

The set pressure for switching collectors prevents the formation of steam, and in extreme cases, its spread into the solar thermal system. Safety devices for the expansion vessels (stagnation cooler or pre-cooling vessel) are not required. For calculating the required pressure, see page 142. If the pressure is set too low, a small amount of steam can form which will normally remain in the collectors and not be pushed into the system. Switching collectors can therefore be used in systems where the collector array is below the DHW cylinder.

Pressure in solar thermal systems with Vitosol-F and Vitosol 200-TM

The pressure set ensures controlled evaporation of the heat transfer medium. Depending on collector type/hydraulics or connection version, the collector has a higher or lower steam-producing power.

This influences the selection and positioning of various technical components of the solar thermal system. In conventional solar thermal systems, where the steam produced can spread as far as the expansion vessel, a stagnation cooler or a pre-cooling vessel are installed to protect the diaphragm.

Do not position the collector array below the DHW cylinder. Otherwise the steam produced during a system standstill can rise towards the DHW cylinder in an uncontrolled manner. In the DHW cylinder, the heat is transferred and the steam condenses and flows back towards the collectors. The result is an uncontrollable system state.

Steam-producing power, pressure maintenance and safety equipment

In the collectors, temperatures are reached that exceed the boiling point of the heat transfer medium. For this reason, solar thermal systems must be designed to be fail-safe in accordance with the relevant regulations.

With regard to stagnation behaviour, with the exception of switching collectors Vitosol-FM and Vitosol 300-TM, a low system pressure is advantageous: **1 bar/0.1 MPa** (during filling and at a heat transfer medium temperature of approx. 20 °C) on the collector is sufficient. A definitive parameter when designing pressure maintenance and safety equipment is the **steam-producing power**. This indicates the power of the collector array, which during stagnation is transferred to the pipework in the form of steam. The maximum steam-producing power is influenced by the draining characteristics of the collectors and the array. Subject to collector type and hydraulic connection, different steam-producing power levels can occur (see diagram below).

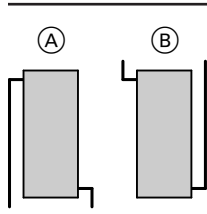

- (A) Flat-plate collector without liquid pocket
Steam-producing power = 60 W/m²
- (B) Flat-plate collector with liquid pocket
Steam-producing power = 100 W/m²

Note

Steam-producing power

- Vitosol 300-TM: 0 W/m²
- Vitosol 200-TM: 60 W/m²

The length of pipe that holds steam during stagnation (steam spread) is calculated from the balance between the steam-producing power of the collector array and the heat loss from the pipework. The actual values assumed for the loss from a solar circuit pipe made from copper and 100 % insulated with commercially available material are as follows:

Dimensions	Heat loss in W/m
12 x 1/15 x 1/18 x 1	25
22 x 1/28 x 1.5	30

- Steam spread is **less** than the pipe run in the solar circuit (flow and return) between collector and expansion vessel:
The steam cannot reach the expansion vessel in the event of stagnation. The displaced volume (collector array and pipework filled with steam) must be taken into account when sizing the expansion vessel.
- Steam spread is **greater** than the pipe run in the solar circuit (flow and return) between collector and expansion vessel:
Include a cooling line (heat sink) in the design, to protect the expansion vessel diaphragms against thermal overload (see diagrams below). Steam condenses in this cooling line and reduces the temperature of the liquefied heat transfer medium to below 70 °C.

Information regarding design and operation (cont.)

Expansion vessel and heat sink in the return

The steam can spread through the flow and return.

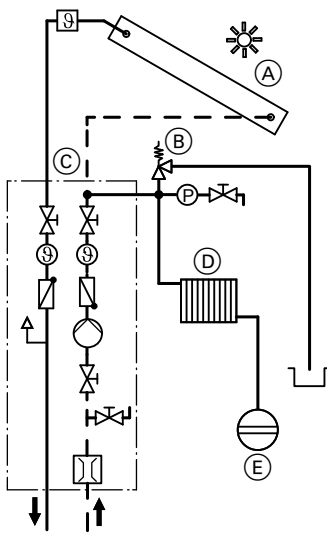

- (A) Collector
- (B) Safety valve
- (C) Solar-Divicon
- (D) Heat sink
- (E) Expansion vessel

Expansion vessel and heat sink in the flow

The steam can only spread through the flow.

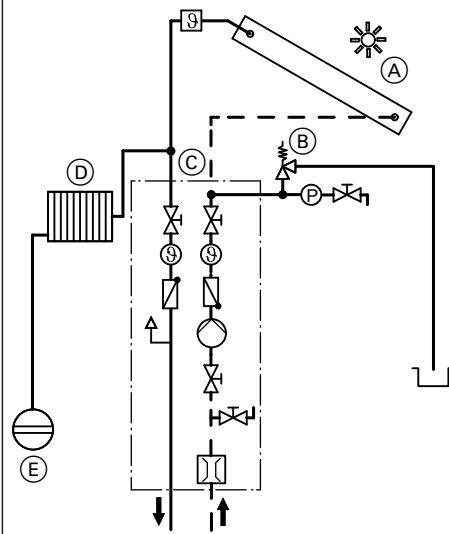

The necessary residual cooling capacity is determined from the differential between the steam-producing power of the collector array and the heat dissipation of the pipework up to the connection point for the expansion vessel and the heat sink.

Note

For calculating the residual cooling capacity and sizing the heat sink, look for the SOLSEC program at www.viessmann.com in the Trade Partner login area under Software-Service.

The program offers 3 options:

- Sufficiently long, uninsulated pipework branching to the expansion vessel
- A sufficiently large pre-cooling vessel, in relation to the cooling capacity
- A correctly sized stagnation cooler

For the heat sink, standard radiators with an output calculated at 115 K are assumed. For greater clarity, the program indicates the heating output at 75/65 °C.

Note

Due to the expected high surface temperatures, Viessmann stagnation coolers (see page 97) are equipped with a plate that receives no flow, for protection against accidental contact. If commercially available radiators are used, protection against accidental contact must be provided. The connections must be diffusion-proof. All components must be able to withstand temperatures of up to 180 °C.

Specification

	Output at 75/65 °C in W	Cooling capacity during stagnation in W	Liquid content in l
Stagnation cooler			
– Type 21	482	964	1
– Type 33	835	1668	2
Pre-cooling vessel	—	450	12

Adjust system pressure

In the case of switching collectors Vitosol-FM and Vitosol 300-TM, the system pressure in the collector must be approx. 3.0 bar.

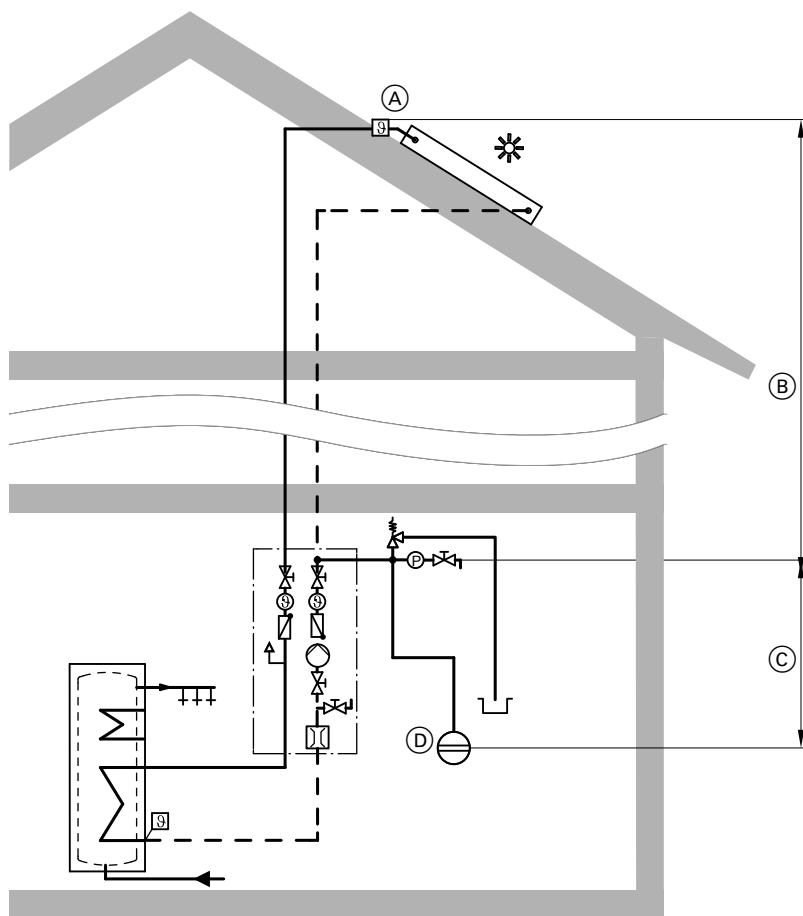

Pressure maintaining facility

	Vitosol-F Vitosol 200-TM	Vitosol-FM Vitosol 300-TM
System pressure Ⓐ	1 bar	3 bar

Pressure conditions calculation examples

System height from upper collector edge to pressure gauge of 10 m

System operating pressure

System pressure Ⓐ at highest point	1 bar	3 bar
Supplement per metre of static head Ⓑ, here 10 m	+ 0.1 bar/m = 1 bar	+ 0.1 bar/m = 1 bar
System operating pressure Ⓟ (pressure gauge)	2 bar	4 bar

Charge pressure

System operating pressure	2 bar	4.0 bar
Pressure reserve for venting	+ 0.1 bar	+ 0.1 bar
Charge pressure	2.1 bar	4.1 bar

Pre-charge pressure, expansion vessel

System operating pressure	2 bar	4.0 bar
Deduction for hydraulic seal	-0.3 bar	-0.3 bar
Supplement per metre of height difference Ⓒ between pressure gauge and expansion vessel	+ 0.1 bar x 1 m = 0.1 bar	+ 0.1 bar x 1 m = 0.1 bar
Expansion vessel pre-charge pressure Ⓣ	1.8 bar	3.8 bar

Expansion vessel

For layout, function and specification of the expansion vessel, see chapter "Installation accessories".
The expansion vessel can be calculated once the steam spread has been determined and any heat sinks that may be used have been taken into consideration.

The required volume is determined by the following factors:

- Expansion of the heat transfer medium in its liquid state
- Liquid seal

Information regarding design and operation (cont.)

- Expected steam volume, taking account of the static head of the system
- Pre-charge pressure

$$V_{dev} = (V_{col} + V_{dpipe} + V_e + V_{fv}) \cdot Df$$

V_{dev}	Nominal volume of the expansion vessel in l
V_{col}	Liquid content of the collectors in l In systems with Vitosol-FM/300-TM this value = 0
V_{dpipe}	Content of the pipework subject to steam loads in l (Calculated from the steam spread and the pipework content per m pipe length) In systems with Vitosol-FM/300-TM this value = 0
V_e	Increase in the volume of the heat transfer medium in its liquid state in l $V_e = V_a \cdot \beta$ V_a System volume (content of the collectors, the heat exchanger and the pipework) β Expansion factor $\beta = 0.1$ to 0.13 for Viessmann heat transfer medium

V_{fv}	Liquid seal in the expansion vessel in l (4 % of the system volume, min. 3 l)
Df	Pressure factor $(p_e + 1) : (p_e - p_o)$ p_e Max. system pressure at the safety valve in bar (90 % of the safety valve response pressure) p_o System pre-charge pressure – Vitosol 200-TM/Vitosol F: $p_o = 1 \text{ bar} + 0.1 \text{ bar/m static head}$ – Vitosol-FM/Vitosol 300-TM: $p_o = 3 \text{ bar} + 0.1 \text{ bar/m static head}$

To determine the system and steam volume in the pipework, the content per m of pipe must be taken into consideration.

Vitotrans 200, type WTT	Part no.	3003453	3003454	3003455	3003456	3003457	3003458	3003459
Capacity	l	4	9	13	16	34	43	61

Copper pipe	Dim.	12 x 1	15 x 1	18 x 1	22 x 1	28 x 1.5	35 x 1.5	42 x 1.5
		DN10	DN13	DN16	DN20	DN25	DN32	DN40
Capacity	l/m pipe	0.079	0.133	0.201	0.314	0.491	0.804	1.195

Corrugated stainless steel pipe	Dim.	DN 16
Capacity	l/m pipe	0.25

For the liquid content of the following components see the relevant "Specification" chapter:

- Collectors
- Solar-Divicon and solar pump assembly
- DHW cylinder and heating water buffer cylinder

Note

Check the size of the expansion vessel on site.

Calculation with "Solsec" design program

For sizing the expansion vessels and calculating the residual cooling capacity, look for the SOLSEC program at www.viessmann.com in the Trade Partner login area under Software-Service.

Safety valve

The heat transfer medium is drained from the solar thermal system via the safety valve if the max. permissible system pressure is exceeded. According to DIN 3320, the response pressure of the safety valve is the max. system pressure +10 %.
The safety valve must comply with EN 12975 and EN 12977, be matched to the heating output of the collectors and be able to handle their maximum output of 900 W/m².

Discharge and drain lines must terminate in an open container, capable of collecting the total content of the collectors.
Viessmann Solar-Divicons are equipped with 6 bar safety valves at the factory. In solar thermal systems equipped with switching collectors, the 6 bar safety valves fitted at the factory can be replaced with 8 bar valves. See accessories, page 92.

Absorber area in m²	Valve size (size of the inlet cross-section) DN
40	15
80	20
160	25

High limit safety cut-out

The solar control units Vitosolic 100 and 200 are equipped with an electronic temperature limiter.
A high limit safety cut-out in the cylinder is required when less than 40 l cylinder capacity is available per m² absorber area. This reliably prevents temperatures above 95 °C in the cylinder.

Example:

- 3 Vitosol-F flat-plate collectors, 7 m² absorber area
- DHW cylinder with 300 l capacity
- 300 : 7 = 42.8 l/m²

A high limit safety cut-out is **not** required.

13.11 Connecting the DHW circulation and automatic thermostatic mixing valve

To ensure trouble-free functioning of the solar thermal system, it is important that, in the DHW cylinder, areas with cold water are available to receive the solar energy. These areas must not be reached by the DHW circulation return. The DHW circulation connection in the DHW cylinder **must** therefore be used (see following diagram). DHW with **temperatures in excess of 60 °C** can cause scalding. To limit the temperature to 60 °C, install a mixing device, e.g. an automatic thermostatic mixing valve (see page 97). If the maximum set temperature is exceeded, the valve mixes cold water into the DHW as it is drawn off.

If the automatic thermostatic mixing valve is used in conjunction with a DHW circulation pipe, a bypass line is required between the DHW circulation inlet on the DHW cylinder and the cold water inlet on the mixing valve. To avoid recirculation, a check valve should be installed (see following diagram).

Note

Viessmann offers a thermostatic DHW circulation set as an accessory (see page 97).

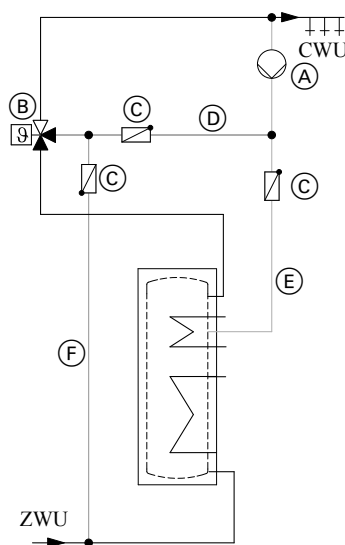

- (A) DHW circulation pump
- (B) Automatic thermostatic mixing valve
- (C) Check valve
- (D) DHW circulation return in summer
Line required to prevent excessive temperatures in summer
- (E) DHW circulation return in winter
Flow temperature max. 60 °C
- (F) Automatic thermostatic mixing valve inlet
Pipe runs as short as possible, as these receive no flow in winter.

13.12 Intended use

The appliance is only intended to be installed and operated in sealed unvented systems that comply with EN 12828 / DIN 1988, or solar thermal systems that comply with EN 12977, with due attention paid to the associated installation, service and operating instructions. DHW cylinders are only designed to store and heat water of potable water quality. Heating water buffer cylinders are only designed to hold fill water of potable water quality. Only operate solar collectors with the heat transfer medium approved by the manufacturer.

Intended use presupposes that a fixed installation in conjunction with permissible, system-specific components has been carried out.

Commercial or industrial usage for a purpose other than heating the building or DHW shall be deemed inappropriate.

Any usage beyond this must be approved by the manufacturer for the individual case.

Incorrect usage or operation of the appliance (e.g. the appliance being opened by the system user) is prohibited and results in an exclusion of liability.

Incorrect usage also occurs if the components in the system are modified from their intended use (e.g. through direct DHW heating in the collector).

Adhere to statutory regulations, especially concerning the hygiene of potable water.

14.1 Subsidy programmes, permits and insurance

Solar thermal systems play an important role in protecting natural resources and the environment. Together with advanced Viessmann heating systems, they create an optimum, futureproof system solution for DHW and swimming pool heating, central heating backup and other low temperature applications. This is why solar thermal systems are frequently subsidised by government.

Application forms and subsidy conditions can be obtained from the Federal Office for Economic Affairs and Export Control (www.bafa.de). Solar thermal systems are subsidised by some national, regional and local authorities. Further information is available from our sales offices.

Information regarding current subsidy programmes is also available at "www.viessmann.com" (Fördermittel [Subsidies]>Förderprogramme des Bundes [Subsidy Programmes in Germany]).

Viessmann collectors meet the requirements of the "Blue Angel" certificate of environmental excellence to RAL UZ 73. The approval of solar thermal systems is not universally regulated. Your local planning office will be able to advise you on whether solar thermal systems need planning permission.

Viessmann solar collectors are tested for impact resistance, for example against hailstones, to EN 12975-2 or ISO 9806. Nevertheless we recommend that the user insures against extreme weather conditions and includes the collectors on their buildings insurance. Damage due to these conditions is excluded from our warranty.

14.2 Glossary

Absorber

Device contained inside a solar collector designed to absorb radiation energy and transfer this as heat to a liquid.

Absorption

Radiation absorption

Irradiance (insolation)

Radiation level impacting on a unit of surface area, expressed in W/m^2

Emission

Radiation of beams, e.g. light or particles

Evacuating

Extraction of the air from a container. This reduces the air pressure, creating a vacuum.

Steam-producing power

The power of the collector array in W/m^2 that, during stagnation, is transferred into the pipework in the form of steam. The max. steam-producing power is influenced by the draining characteristics of the collectors and the collector array (see page 140).

Steam spread

Length of the pipework that is subjected to steam loads during stagnation. The max. steam spread is dependent on the heat loss characteristics of the pipework (thermal insulation). Conventional details refer to 100 % insulation thickness.

Heat pipe

Sealed capillary container that contains a small volume of highly volatile liquid.

Condenser

Device where steam is precipitated as a liquid.

Convection

Transfer of heat by the flow of a medium. Convection creates energy losses caused by a temperature differential, e.g. between the glass pane of the collector and the hot absorber

Standard roof pitch

The roof pitch limit, at which the roof cover is considered to be adequately protected against the ingress of rain, is described as the standard roof pitch.

The rules stated here correspond to the rules of the [German] roofing contractor trade. Observe the manufacturer's instructions if these differ.

Selective surface

The absorber in the solar collector has a highly selective coating to improve its efficiency. This specially applied coating enables the absorption to be maintained at a very high level for the sunlight spectrum that hits the absorber (approx. 94 %). The emission of long-wave heat radiation is largely prevented. The highly selective black chromium coating is very durable.

Radiation energy

Volume of energy transmitted by radiation

Dispersion

Interaction of radiation with matter by which the direction of the radiation is altered. Total energy and wavelength remain unchanged.

Vacuum

A space devoid of air

Heat transfer medium

Liquid that absorbs the available heat in the absorber of the collector and delivers it to a consumer (heat exchanger)

Efficiency

The operating efficiency of a solar collector is the ratio of the collector output to the power input. Relevant variables are e.g. the ambient and absorber temperatures.

Keyword index

A		I	
Above roof installation		Inclination of the receiver surface.....	10
– For corrugated sheet roofs.....	113	Installation accessories.....	89
– For sheet metal roofs.....	114	Installation examples.....	129
– With rafter anchors.....	104	Installation information	
– With rafter hooks.....	108	– Pipework.....	101
Absorber area.....	7	– Solar lines.....	101
Anti-scalding protection.....	144	– Thermal insulation.....	101
Aperture area.....	7	Installation on walls.....	123
Area designations.....	7	Insurance.....	145
Assignment of functions.....	31	Intended use.....	144
Automatic thermostatic mixing valve.....	144		
C		L	
Central heating.....	126	Lightning protection of the solar thermal system.....	101
Central heating backup.....	126	Line regulating valve.....	96
Circulation pump.....	138	Liquid content.....	143
Collector areas.....	7		
Collector efficiency.....	7	O	
Collector fixing.....	102	Operating modes of a solar thermal system	
Collector range.....	6	– High flow operation.....	129
Collector row clearance.....	114	– Low flow operation.....	129
Collector supports on pitched roofs.....	108	– Matched flow operation.....	129
Collector temperature sensor.....	38	Optical efficiency.....	7
Connection line.....	93	Orientation of the receiver surface.....	10
Cooling line.....	140		
D		P	
Delivered condition		Parameters for collectors.....	7
– Solar control module.....	26	Permits.....	145
– Vitosolic 100.....	27	Pressure drop.....	133
– Vitosolic 200.....	28	Pressure drop of the pipework.....	137
DHW cylinders.....	42	Pressure in solar thermal systems.....	140
DHW demand.....	125		
DHW heating.....	125	R	
Distance from the edge of the roof.....	100	Required roof area — above roof.....	103
E		S	
Efficiency curves.....	7	Safety equipment.....	139
EM-S1 extension (ADIO).....	29	Safety valve.....	143
Equipotential bonding.....	101	Shading of the receiver surface.....	10
Expansion vessel.....	141, 142	Sizing.....	124
– Structure, function, specification.....	96	Sizing the circulation pump.....	138
		Snow load zones.....	100
F		Solar control module	
Fill station, solar circuit.....	99	– Delivered condition.....	26
Flat roof installation		– Specification.....	26
– Horizontal.....	122	Solar control units.....	26
– On collector supports.....	114	Solar coverage.....	9
Flow rate.....	129	Solar-Divicon.....	89
Flow velocity.....	136	Solar extension.....	29
		– Specification.....	30
G		Solar flow and return lines.....	95
Gross area.....	7	Solar heat exchanger set.....	59
		Solar line roof outlet.....	95
H		Solar pump assembly.....	89
Heat exchanger.....	128	Specification	
Heat loss factor.....	7	– Extension EM-S1.....	30
High limit safety cut-out.....	143	– Solar control module.....	26
Hydraulic connections.....	129	Stagnation.....	139
		Stagnation temperature.....	9
		Steam-producing power.....	9, 140
		Steam spread.....	140
		Subsidy programmes.....	145
		Swimming pool heating	
		– Indoor pools.....	128
		– Outdoor pools.....	127
		T	
		Technical Building Regulations for installation on walls.....	103
		Thermal capacity.....	9
		Transport aid.....	100

Keyword index

V

Ventilation.....	139
Viessmann collector range.....	6
Vitosolic 100	
– Delivered condition.....	27
Vitosolic 200	
– Delivered condition.....	28

W

Wind load zones.....	100
----------------------	-----

Subject to technical modifications.

Viessmann Werke GmbH & Co. KG
D-35107 Allendorf
Telephone: +49 6452 70-0
Fax: +49 6452 70-2780
www.viessmann.com

Viessmann Limited
Hortonwood 30, Telford
Shropshire, TF1 7YP, GB
Telephone: +44 1952 675000
Fax: +44 1952 675040
E-mail: info-uk@viessmann.com