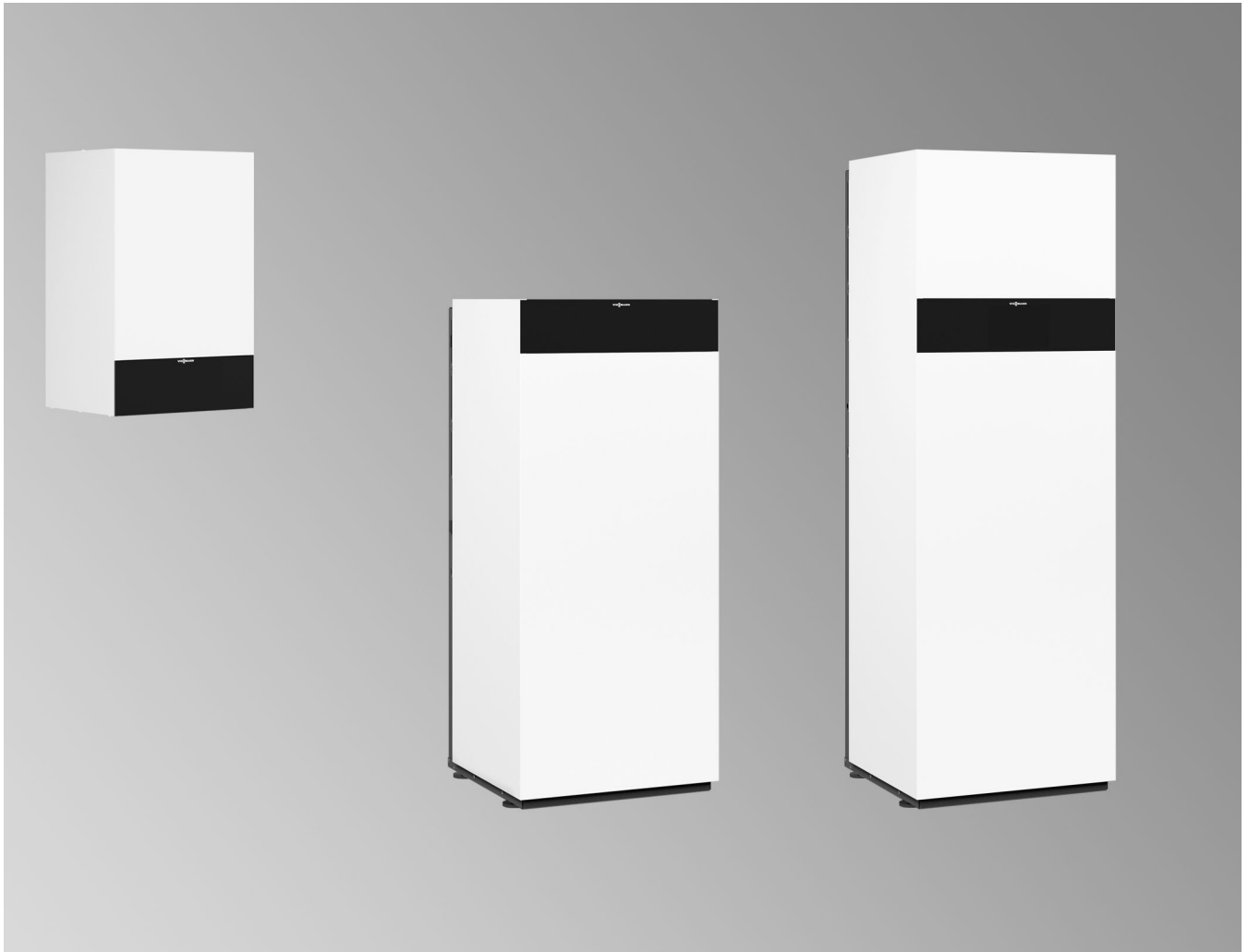

Technical guide

**VITODENS 200-W** Type B2HE, B2KE

Wall mounted gas condensing boiler
1.9 to 32.0
for natural gas and LPG

VITODENS 222-W Type B2LE

Wall mounted gas condensing boiler
1.9 to 32.0
for natural gas and LPG

VITODENS 222-F Type B2SE

Gas condensing storage combi boiler
1.9 to 32.0 kW
for natural gas and LPG

VITODENS 222-F Type B2TE

Gas condensing storage combi boiler
5853906 GB 8/2019

1.9 to 32.0 kW
for natural gas and LPG

VITODENS 242-F Type B2UE

Gas/solar condensing storage combi boiler with solar
DHW heating
1.9 to 25.0 kW
for natural gas and LPG

Index

1.	Vitodens 200-W	1.1 Product description	4
		1.2 Specification	6
2.	Vitodens 222-W	2.1 Product description	15
		2.2 Specification	17
3.	Vitodens 222-F, type B2SE	3.1 Product description	22
		3.2 Specification	25
4.	Vitodens 222-F, type B2TE	4.1 Product description	31
		4.2 Specification	34
5.	Vitodens 242-F	5.1 Product description	39
		5.2 Specification	42
6.	Separate DHW cylinders for Vitodens 200-W	6.1 Vitocell 100-W below the boiler (type CUGA and CUGA-A), made from steel, with Ceraprotect enamel coating	48
		■ Delivered condition	50
		6.2 Vitocell 100-W, type CVA, CVAA and CVAA-A adjacent to the boiler – 160, 200 and 300 l, white finish, made from steel, with Ceraprotect enamel coating	51
		■ Delivered condition	54
		6.3 Vitocell 200-W, type EVIA-A and EVIA-A+adjacent to the boiler, 160 and 200 l, white finish, with internal indirect coil, made from stainless steel	55
		■ Delivered condition	56
		6.4 Vitocell 100-W, type CVB and CVBB adjacent to the boiler – 300 and 400 l, white finish, made from steel with Ceraprotect enamel coating for dual mode DHW heating	58
		■ Delivered condition	61
7.	Installation accessories	7.1 Vitodens 200-W installation accessories	62
		■ Pre-plumbing jigs	62
		■ Valves/fittings	63
		■ Sub-mounting kit with mixer	64
		■ Mounting frame	66
		■ Further accessories	67
		■ Connections between the Vitodens and the DHW cylinder	70
		7.2 Installation accessories for Vitodens 222-W	71
		■ Pre-plumbing jigs	71
		■ Mounting frame	71
		■ Valves/fittings	72
		■ Sub-mounting kit with mixer	72
		■ Further accessories	75
		■ Flue gas cascade (positive pressure) for multi boiler systems with Vitodens 200-W and 222-W	76
		7.3 Installation accessories for Vitodens 222-F	77
		7.4 Installation accessories for Vitodens 242-F	81
		7.5 Divicon heating circuit distributor and low loss headers	86
		■ Divicon heating circuit distributor	86
		■ Low loss headers	93
8.	Design information	8.1 Siting, installation	94
		■ Siting conditions for open flue operation (appliance type B)	94
		■ Siting conditions for room sealed operation (appliance type C)	94
		■ Siting the Vitodens 222-F and 242-F in recesses	95
		■ Operation of the Vitodens in wet rooms	95
		■ Electrical connection	96
		■ Gas connection	96
		■ Minimum clearances	97
		■ Installation of the Vitodens 200-W	97
		■ Replacing third party boilers with the Vitodens 200-W	105
		■ Pre-installation of the Vitodens 222-W	109
		■ Installation of the Vitodens 222-F	115
		■ Installation of the Vitodens 242-F	121
		8.2 Decision making aids for DHW heating	125
		■ Information on water quality	125
		■ Separate DHW cylinders	126
		■ Sizing the DHW cylinder	126
		■ DHW cylinder selection tables	127
		8.3 Connections on the water side	127

	■ Connection on the DHW side	127
8.4	Condensate connection	132
	■ Condensate drain pipe and neutralisation	133
8.5	Hydraulic connection	134
	■ General	134
	■ Expansion vessels	135
	■ Low loss header	136
8.6	Intended use	137
9.	Control unit	
9.1	Layout and functions	137
	■ Control unit with 7-inch screen – modular design	137
	■ Control unit with 3.5-inch screen – modular design	138
	■ Functions	139
	■ Information on PlusBus subscribers	140
	■ Frost protection function	140
	■ Heating curve setting (slope and level)	140
	■ Heating systems with a low loss header or heating water buffer cylinder	140
	■ Flow temperature sensor	140
	■ Cylinder temperature sensor	140
9.2	Specification – control unit	141
9.3	Accessories for control unit	141
	■ Vitotrol 100, type UTA	141
	■ Vitotrol 100, type UTDB	142
	■ Vitotrol 100, type UTDB-RF	142
	■ Vitotrol 200-E	143
	■ Outside temperature sensor	144
	■ Room temperature sensor	144
	■ Immersion temperature sensor	144
	■ Cylinder temperature sensor	145
	■ Contact thermostat	145
	■ Information on PlusBus subscribers	145
	■ EM-MX mixer extension kit with integral mixer motor	145
	■ EM-M1 mixer extension kit for separate mixer motor	146
	■ EM-MX mixer extension kit for Divicon heating circuit distribution	146
	■ EM-P1 extension	147
	■ Solar control units	148
	■ EM-EA1 extension	150
10.	Appendix	
10.1	Regulations / Directives	151
	■ Regulations and directives	151
11.	Keyword index	152

1.1 Product description

Control unit with 7-inch screen

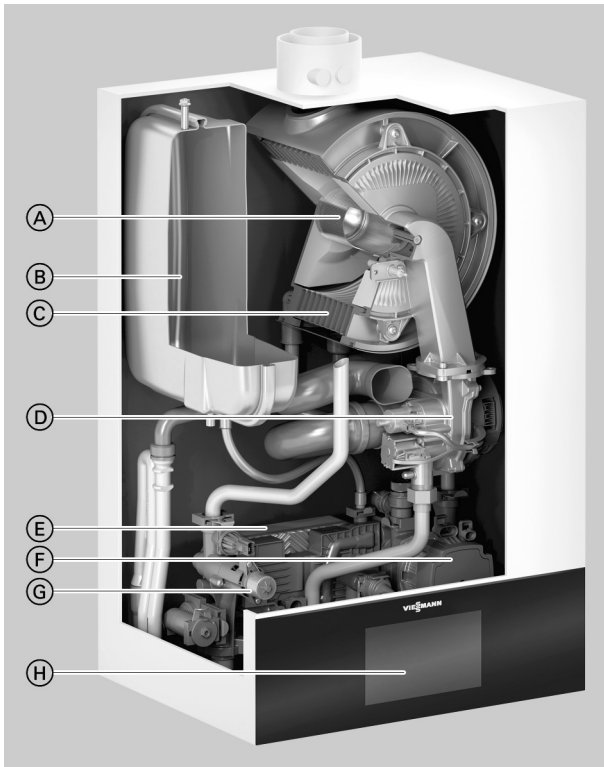

- Ⓐ Modulating MatriX-Plus gas burner with intelligent Lambda Pro Plus combustion controller for extremely clean combustion and quiet operation
- Ⓑ Integral diaphragm expansion vessel
- Ⓒ Inox-Radial heat exchanger made from stainless steel – for high operational reliability, a long service life and high heating output on a very small footprint
- Ⓓ Variable speed combustion air fan for quiet and economical operation
- Ⓔ Plate heat exchanger for DHW heating (gas condensing combi boiler)
- Ⓕ Integral, variable speed high efficiency circulation pump
- Ⓖ Hydraulics
- Ⓗ Digital boiler control unit with colour touchscreen

Control unit with 3.5-inch screen

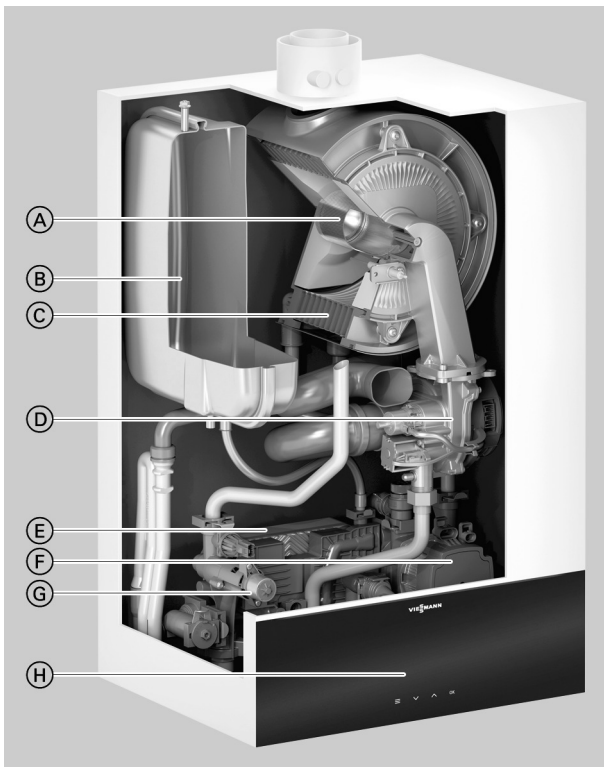

- Ⓐ Modulating MatriX-Plus gas burner with intelligent Lambda Pro Plus combustion controller for extremely clean combustion and quiet operation
- Ⓑ Integral diaphragm expansion vessel
- Ⓒ Inox-Radial heat exchanger made from stainless steel – for high operational reliability, a long service life and high heating output on a very small footprint
- Ⓓ Variable speed combustion air fan for quiet and economical operation
- Ⓔ Plate heat exchanger for DHW heating (gas condensing combi boiler)
- Ⓕ Integral, variable speed high efficiency circulation pump
- Ⓖ Hydraulics
- Ⓗ Digital boiler control unit with black/white screen

Vitodens 200-W (cont.)

The top model among the wall mounted gas condensing boilers is the Vitodens 200-W. The MatriX-Plus gas burner and Inox-Radial heat exchanger made of stainless steel are a combination that guarantees high efficiency and a high level of heating convenience over the long term.

All sizes of the Vitodens 200-W are equipped with the automatic Lambda Pro Plus combustion controller. Modulation range down to 1:17 (32 kW).

The integral, variable speed high efficiency circulation pump reduces power consumption by up to 70 %.

Recommended applications

- Modernisation of heating systems on single floors or in detached houses with high demands for central heating and DHW convenience
- Systems with little space available for the heat generator or tight (flexible) installation locations (e.g. attic or inside furniture)
- Replacement of existing floorstanding boilers in various systems, also with several heating circuits and underfloor heating

Benefits at a glance

Control unit with 7-inch screen

- Seasonal central heating energy efficiency η_s up to 94 % (label A).
- Low cycle frequency, even with low heat demand, through optimised pauses and wide modulation range down to 1:17 (32 kW)
- Durable and efficient thanks to Inox-Radial stainless steel heat exchanger
- MatriX-Plus gas burner with Lambda Pro Plus combustion controller for permanently high efficiency and clean combustion.
- Power saving, high efficiency circulation pump
- Colour touchscreen with plain text and graphic display, commissioning assistant, energy consumption indicators and the option of operation from a mobile device
- Web-enabled through integral WiFi interface for operation and service via Viessmann app

Benefits at a glance

Control unit with 3.5-inch screen

- Seasonal central heating energy efficiency η_s up to 94 % (label A).
- Low cycle frequency, even with low heat demand, through optimised pauses and wide modulation range down to 1:17 (32 kW)
- Durable and efficient thanks to Inox-Radial stainless steel heat exchanger
- MatriX-Plus gas burner with Lambda Pro Plus combustion controller for permanently high efficiency and clean combustion.
- Power saving, high efficiency circulation pump
- Black/white screen with plain text and graphic display, commissioning assistant, energy consumption indicators and the option of operation from a mobile device
- Web-enabled through integral WiFi interface for operation and service via Viessmann app

Delivered condition

Wall mounted gas condensing boiler with Inox-Radial heat exchanger, modulating MatriX-Plus gas burner for natural gas and LPG to DVGW Code of Practice G260 [Germany], hydraulics and variable speed high efficiency circulation pump.

Weather-compensated or constant temperature control unit with integral WiFi interface.

Fully plumbed and wired. Colour of the epoxy-coated casing: White. Integral diaphragm expansion vessel (10 l capacity).

Preset for operation with natural gas. Conversion within gas groups E/LL is not required. The conversion to LPG is made at the control unit (a conversion kit is not required).

Accessories required (order separately)

Vitodens installation directly on a wall

Pre-plumbing jig for surface mounting:

- With fixings
- With valves/fittings
- With boiler drain & fill valve
- With gas shut-off valve with thermally activated safety shut-off valve

Valves/fittings for surface mounting:

- With valves/fittings
- With boiler drain & fill valve
- With gas shut-off valve with thermally activated safety shut-off valve

Valves/fittings for flush mounting:

- With valves/fittings
- With boiler drain & fill valve
- With gas shut-off valve with thermally activated safety shut-off valve

Mounting frame for surface mounting (installed depth 90 mm):

- With fixings
- With valves/fittings
- With boiler drain & fill valve
- With angle gas valve with thermally activated safety shut-off valve

Vitodens installation in front of a wall

Plumbing wall mounting frame (installed depth 110 mm):

- With fixings

A pre-plumbing jig or valves/fittings for surface mounting/flush mounting must be ordered separately for the plumbing wall mounting frame.

Tested quality

 CE designation according to current EU Directives

Meets the requirements for the "Blue Angel" ecolabel to RAL UZ 61.

1.2 Specification

Gas condensing system boiler

Gas boiler, type B and C, category II _{2N3P}		B2HE			
Type					
Rated heating output range (details to EN 15502)					
T _F /T _R = 50/30 °C					
Natural gas	kW	1.9 - 11.0	1.9 - 19.0	1.9 - 25.0	1.9 - 32.0
LPG	kW	2.5 - 11.0	2.5 - 19.0	2.5 - 25.0	2.5 - 32.0
T _F /T _R = 80/60 °C					
Natural gas	kW	1.7 - 10.1	1.7 - 17.4	1.7 - 22.9	1.7 - 29.3
LPG	kW	2.2 - 10.1	2.2 - 17.4	2.2 - 22.9	2.2 - 29.3
Rated heating output for DHW heating					
Natural gas	kW	1.7 - 17.4	1.7 - 17.4	1.7 - 22.9	1.7 - 29.3
LPG	kW	2.2 - 17.4	2.2 - 17.4	2.2 - 22.9	2.2 - 29.3
Rated heat input					
Natural gas	kW	1.8 - 17.8	1.8 - 17.8	1.8 - 23.4	1.8 - 29.9
LPG	kW	2.3 - 17.8	2.3 - 17.8	2.3 - 23.4	2.3 - 29.9
Product ID		CE-0085CT0017			
IP rating to EN 60529		IP X4			
Gas supply pressure					
Natural gas	mbar	20	20	20	20
	kPa	2	2	2	2
LPG	mbar	50	50	50	50
	kPa	5	5	5	5
Max. permiss. gas supply pressure^{*1}					
Natural gas	mbar	25.0	25.0	25.0	25.0
	kPa	2.5	2.5	2.5	2.5
LPG	mbar	57.5	57.5	57.5	57.5
	kPa	5.75	5.75	5.75	5.75
Sound power level (to EN ISO 15036-1)					
At partial load	dB(A)	27	27	27	27
At rated heating output (DHW heating)	dB(A)	41	41	42	47
Power consumption (in the delivered condition)	W	37	47	68	92
Weight					
– Excl. heating water and packaging	kg	33.0	33.0	33.0	33.0
– Incl. heating water	kg	38.6	38.6	38.6	38.6
Water capacity (excl. diaphragm expansion vessel)	l	3.0	3.0	3.0	3.0
Max. flow temperature	°C	82	82	82	82
Max. flow rate (Limit for the use of hydraulic separation)	l/h	See residual head graph			
Nominal circulating water volume At T _F /T _R = 80/60 °C	l/h	473	818	1076	1374
Diaphragm expansion vessel					
Capacity	l	10	10	10	10
Pre-charge pressure	bar	0.75	0.75	0.75	0.75
	kPa	75	75	75	75
Permiss. operating pressure	bar	3	3	3	3
	MPa	0.3	0.3	0.3	0.3
Dimensions					
Length	mm	360	360	360	360
Width	mm	450	450	450	450
Height	mm	700	700	700	700
Gas connection	R	¾	¾	¾	¾
Supply values Relative to the max. load and 1013 mbar/15 °C					
With gas					
Natural gas E	m ³ /h	1.88	1.88	2.48	3.16
Natural gas LL	m ³ /h	2.19	2.19	2.88	3.68
LPG	kg/h	1.38	1.38	1.82	2.32

*1 If the gas supply pressure is higher than the maximum permissible value, install a separate gas pressure governor upstream of the system.

Vitodens 200-W (cont.)

Gas boiler, type B and C, category II _{2N3P}		B2HE			
Type					
Rated heating output range (details to EN 15502)					
T _F /T _R = 50/30 °C					
Natural gas	kW	1.9 - 11.0	1.9 - 19.0	1.9 - 25.0	1.9 - 32.0
LPG	kW	2.5 - 11.0	2.5 - 19.0	2.5 - 25.0	2.5 - 32.0
T _F /T _R = 80/60 °C					
Natural gas	kW	1.7 - 10.1	1.7 - 17.4	1.7 - 22.9	1.7 - 29.3
LPG	kW	2.2 - 10.1	2.2 - 17.4	2.2 - 22.9	2.2 - 29.3
Flue gas parameters					
Temperature (at a return temperature of 30 °C)					
– At rated heating output	°C	39	41	46	59
– At partial load	°C	38	38	38	38
Temperature (at a return temperature of 60 °C, for DHW heating)	°C	64	65	67	72
Mass flow rate (for DHW heating)					
Natural gas					
– At rated heating output	kg/h	31.7	31.7	41.6	54.9
– At partial load	kg/h	3.2	3.2	3.2	3.2
LPG					
– At rated heating output	kg/h	30.1	30.1	41.0	53.9
– At partial load	kg/h	3.9	3.9	3.9	3.9
Available draught ^{*2}	Pa	250	250	250	250
	mbar	2.5	2.5	2.5	2.5
Max. amount of condensate	l/h	2.5	2.5	3.3	4.2
To DWA-A 251					
Condensate connection (hose nozzle)	Ø mm	20 - 24	20 - 24	20 - 24	20 - 24
Flue gas connection	Ø mm	60	60	60	60
Ventilation air connection	Ø mm	100	100	100	100
Standard seasonal efficiency [to DIN] at		Up to 98 (H _s) [gross cv]			
T _F /T _R = 40/30 °C		%			
Energy efficiency class		A	A	A	A

Gas condensing combi boiler

Gas boiler, type B and C, category II _{2N3P}		B2KE			
Type					
Rated heating output range (details to EN 15502)					
T _F /T _R = 50/30 °C					
Natural gas	kW	1.9 - 19.0	1.9 - 25.0	1.9 - 32.0	
LPG	kW	2.5 - 19.0	2.5 - 25.0	2.5 - 32.0	
T _F /T _R = 80/60 °C					
Natural gas	kW	1.7 - 17.4	1.7 - 22.9	1.7 - 29.3	
LPG	kW	2.2 - 17.4	2.2 - 22.9	2.2 - 29.3	
Rated heating output for DHW heating					
Natural gas	kW	1.7 - 26.2	1.7 - 30.4	1.7 - 33.5	
LPG	kW	2.2 - 26.2	2.2 - 30.4	2.2 - 33.5	
Rated heat input					
Natural gas	kW	1.8 - 27.3	1.8 - 31.7	1.8 - 34.9	
LPG	kW	2.3 - 27.3	2.3 - 31.7	2.3 - 34.9	
Product ID		CE-0085CT0017			
IP rating to EN 60529		IP X4			
Gas supply pressure					
Natural gas	mbar	20	20	20	
	kPa	2	2	2	
LPG	mbar	50	50	50	
	kPa	5	5	5	
Max. perm. gas supply pressure ^{*3}					
Natural gas	mbar	25.0	25.0	25.0	
	kPa	2.5	2.5	2.5	

*2 CH: Available draught 200 Pa; 2.0 mbar

*3 If the gas supply pressure is higher than the maximum permissible value, install a separate gas pressure governor upstream of the system.

Vitodens 200-W (cont.)

Gas boiler, type B and C, category II _{2N3P}		B2KE		
Type				
Rated heating output range (details to EN 15502)				
T _F /T _R = 50/30 °C				
Natural gas	kW	1.9 - 19.0	1.9 - 25.0	1.9 - 32.0
LPG	kW	2.5 - 19.0	2.5 - 25.0	2.5 - 32.0
T _F /T _R = 80/60 °C				
Natural gas	kW	1.7 - 17.4	1.7 - 22.9	1.7 - 29.3
LPG	kW	2.2 - 17.4	2.2 - 22.9	2.2 - 29.3
LPG	mbar	57.5	57.5	57.5
	kPa	5.75	5.75	5.75
Sound power level (to EN ISO 15036-1)				
At partial load	dB(A)	27	27	27
At rated heating output (DHW heating)	dB(A)	41	42	47
Power consumption (in the delivered condition)	W	47	68	92
Weight				
– Excl. heating water and packaging	kg	34.0	34.0	34.0
– Incl. heating water	kg	40.1	40.1	40.1
Water capacity (excl. diaphragm expansion vessel)	l	3.0	3.0	3.0
Max. flow temperature	°C	82	82	82
Max. flow rate (Limit for the use of hydraulic separation)	l/h	See residual head graph		
Nominal circulating water volume At T _F /T _R = 80/60 °C	l/h	818	1076	1374
Diaphragm expansion vessel				
Capacity	l	10	10	10
Pre-charge pressure	bar	0.75	0.75	0.75
	kPa	75	75	75
Permiss. operating pressure	bar	3	3	3
	MPa	0.3	0.3	0.3
Dimensions				
Length	mm	360	360	360
Width	mm	450	450	450
Height	mm	700	700	700
Gas connection	R	$\frac{3}{4}$	$\frac{3}{4}$	$\frac{3}{4}$
Standby instantaneous water heater				
Hot and cold water connections	G	$\frac{1}{2}$	$\frac{1}{2}$	$\frac{1}{2}$
Permiss. operating pressure (DHW side)	bar	10	10	10
	MPa	1	1	1
Minimum pressure, cold water connection	bar	1.0	1.0	1.0
	MPa	0.1	0.1	0.1
Outlet temperature, adjustable	°C	30-60	30-60	30-60
Continuous DHW output	kW	26.2	30.4	33.5
Spec. flow rate	l/min	14.45	15.59	17.04
At $\Delta T = 30$ K (to EN 13203-1)				
Supply values Relative to the max. load and 1013 mbar/15 °C				
With gas				
Natural gas E	m ³ /h	2.89	3.35	3.69
Natural gas LL	m ³ /h	3.36	3.90	4.29
LPG	kg/h	2.12	2.46	2.71



Vitodens 200-W (cont.)

Gas boiler, type B and C, category II _{2N3P}		B2KE		
Type				
Rated heating output range (details to EN 15502)				
$T_F/T_R = 50/30\text{ °C}$				
Natural gas	kW	1.9 - 19.0	1.9 - 25.0	1.9 - 32.0
LPG	kW	2.5 - 19.0	2.5 - 25.0	2.5 - 32.0
$T_F/T_R = 80/60\text{ °C}$				
Natural gas	kW	1.7 - 17.4	1.7 - 22.9	1.7 - 29.3
LPG	kW	2.2 - 17.4	2.2 - 22.9	2.2 - 29.3
Flue gas parameters				
Temperature (at a return temperature of 30 °C)				
– At rated heating output	°C	41	46	59
– At partial load	°C	38	38	38
Temperature (at a return temperature of 60 °C, for DHW heating)	°C	70	74	77
Mass flow rate (for DHW heating)				
Natural gas				
– At rated heating output	kg/h	49.3	57.3	62.1
– At partial load	kg/h	3.2	3.2	3.2
LPG				
– At rated heating output	kg/h	49.2	57.1	61.1
– At partial load	kg/h	3.9	3.9	3.9
Available draught ^{*4}	Pa	250	250	250
	mbar	2.5	2.5	2.5
Max. amount of condensate	l/h	2.5	3.3	4.2
To DWA-A 251				
Condensate connection (hose nozzle)	Ø mm	20 - 24	20 - 24	20 - 24
Flue gas connection	Ø mm	60	60	60
Ventilation air connection	Ø mm	100	100	100
Standard seasonal efficiency [to DIN] at		Up to 98 (H _s) [gross cv]		
$T_F/T_R = 40/30\text{ °C}$	%			
Energy efficiency class		A	A	A

1

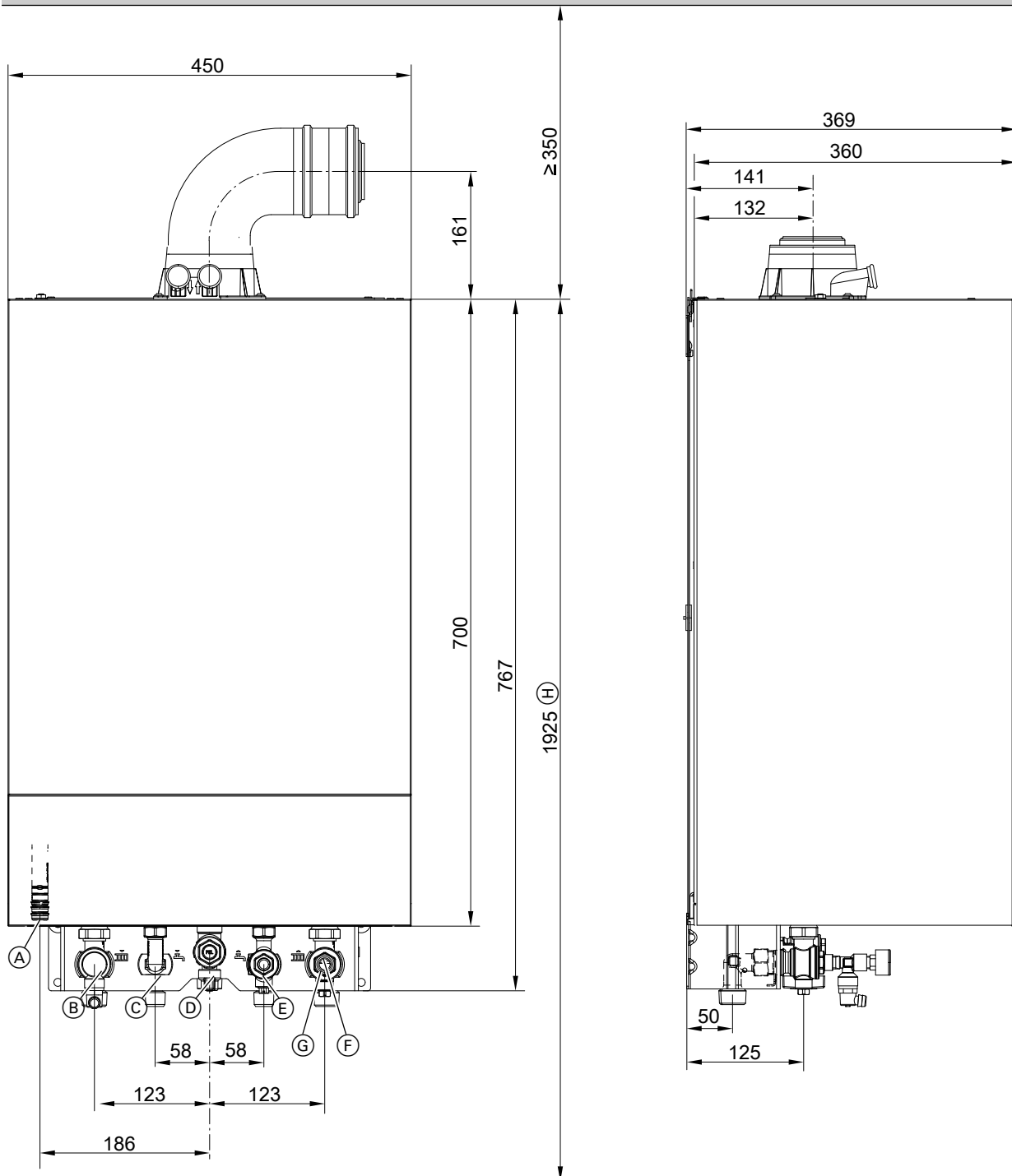

Illustration shows a gas condensing combi boiler

- (A) Condensate drain
- (B) Heating flow
- (C) DHW (gas condensing combi boiler)
Cylinder flow (gas condensing system boiler)
- (D) Gas connection
- (E) Cold water (gas condensing combi boiler)
Cylinder return (gas condensing system boiler)
- (F) Heating return
- (G) Filling/draining
- (H) Dimension for installation with DHW cylinder below the boiler

Vitodens 200-W (cont.)

Note

The appliance is delivered fitted with a flexible power cable (2 m long). Lay the required power cables on site and route them into the boiler through the underside.

Variable speed heating circuit pump in the Vitodens 200-W

The integral circulation pump is a highly efficient pump with substantially lower power consumption than conventional pumps. The pump speed and consequently the pump rate are regulated subject to the outside temperature and the switching times for heating mode or reduced mode. The control unit transmits the current speed specifications to the circulation pump via a PWM signal. The min. and max. speeds and the speed for reduced mode can be matched to the existing heating system via parameters at the control unit.

Setting (%) in the heating circuit 1 group:

- Min. speed: Parameter 1102.0
- Max. speed: Parameter 1102.1

- In the delivered condition, the minimum pump rate and the maximum pump rate are set to the following values:

Rated heating output in kW	Speed settings in the delivered condition in %	
	Min. pump rate	Max. pump rate
11	65	65
19	65	75
25	65	90
32	60	100

- In conjunction with a low loss header, heating water buffer cylinder and heating circuits with mixer, the internal circulation pump runs at a constant speed.

Specification – circulation pump

Rated heating output	kW	11	19	25	32	32
Type		B2HE	B2HE B2KE	B2HE B2KE	B2HE	B2KE
Circulation pump	Type	UPM3 15-60	UPM3 15-60	UPM3 15-60	UPM3 15-60	UPM3 15-75
Rated voltage	V~	230	230	230	230	230
Power consumption						
– Max.	W	42	42	42	42	60
– Min.	W	2	2	2	2	2
– Delivered condition	W	14.6	21.9	34.3	42.0	60.0
Energy efficiency class		A	A	A	A	A
Energy efficiency index (EEI)		≤ 0.20	≤ 0.20	≤ 0.20	≤ 0.20	≤ 0.20

Vitodens 200-W (cont.)

Residual head of integral circulation pump

Gas condensing system boiler up to 32 kW and gas condensing combi boiler up to 25 kW

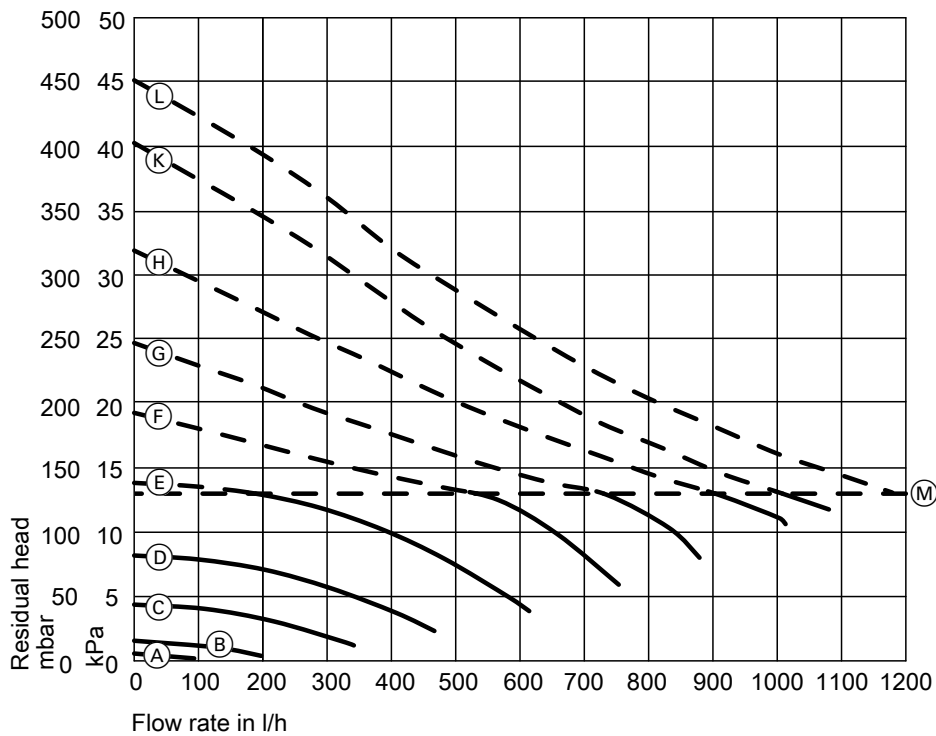

(M) Upper operational limit (integral bypass opens)

Curve	Pump rate, circulation pump
(A)	10 %
(B)	20 %
(C)	30 %
(D)	40 %
(E)	50 %
(F)	60 %
(G)	70 %
(H)	80 %
(K)	90 %
(L)	100 %

Vitodens 200-W (cont.)

Gas condensing combi boiler 32 kW

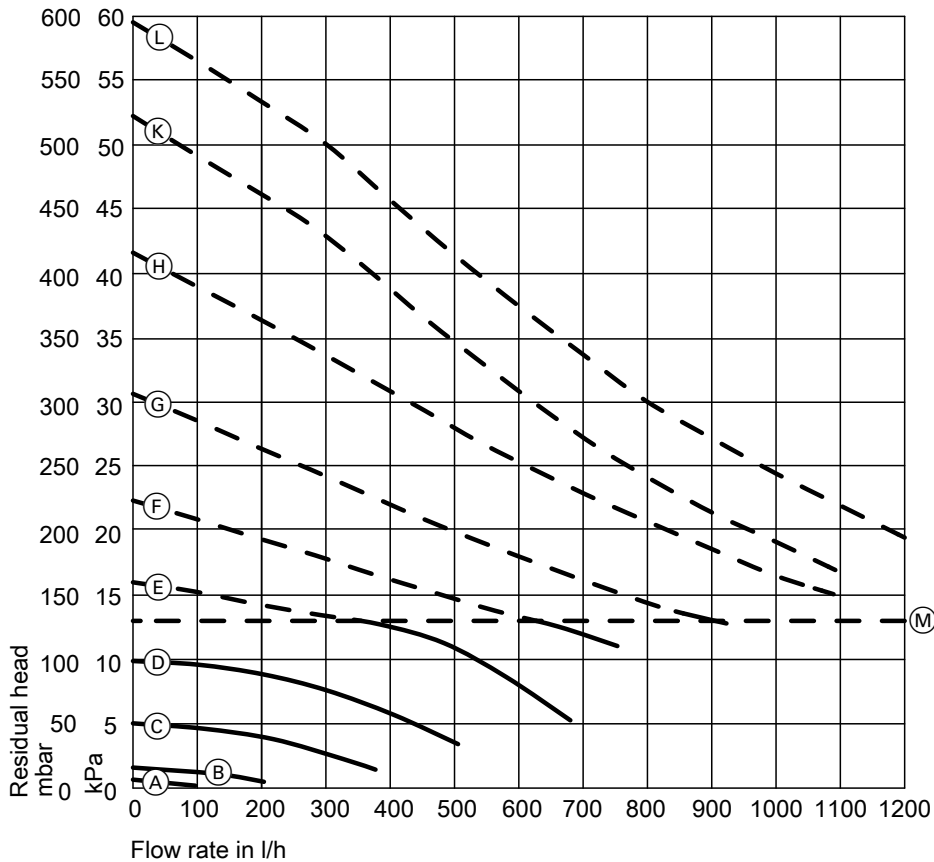

(M) Upper operational limit (integral bypass opens)

Curve	Pump rate, circulation pump
(A)	10 %
(B)	20 %
(C)	30 %
(D)	40 %
(E)	50 %
(F)	60 %
(G)	70 %
(H)	80 %
(K)	90 %
(L)	100 %

Standby instantaneous water heater (gas condensing combi boiler)

A standby instantaneous water heater is integrated into the Vitodens 200-W, type B2KE.

Output levels

Rated heating output, gas condensing combi boiler	kW	19.0	25.0	32.0
Continuous DHW output	kW	26.2	30.4	33.5
For DHW heating from 10 to 45 °C	l/h	737	775	839
Draw-off rate	l/min	3-12	3-14	3-16
Outlet temperature, adjustable	°C	30-60	30-60	30-60

Vitodens 200-W (cont.)

DHW temperature subject to flow rate

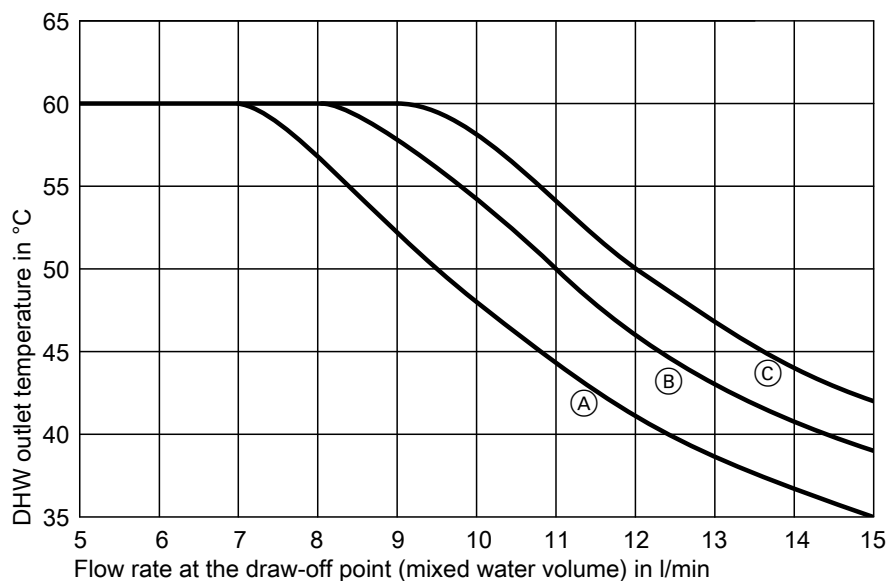

- Ⓐ Vitodens 200-W, 19 kW
- Ⓑ Vitodens 200-W, 25 kW
- Ⓒ Vitodens 200-W, 32 kW

The graph illustrates the changes in the outlet temperature, subject to the flow rate at the draw-off point.

If a greater volume of water is required, cold water needs to be admixed, which reduces the outlet temperature.

The illustrated outlet temperature characteristics are based on a cold water inlet temperature of 10 °C.

Vitodens 222-W

2.1 Product description

Control unit with 7-inch screen



- (A) Loading cylinder made from stainless steel
- (B) Inox-Radial heat exchanger made from stainless steel – for high operational reliability, a long service life and high heating output on a very small footprint
- (C) Modulating Matrix-Plus gas burner with intelligent Lambda Pro Plus combustion controller for extremely clean combustion and quiet operation
- (D) Integral diaphragm expansion vessel
- (E) Variable speed combustion air fan for quiet and economical operation
- (F) Plate heat exchanger
- (G) Hydraulics with integral, variable speed high efficiency circulation pump
- (H) Digital boiler control unit with colour touchscreen

Control unit with 3.5-inch screen



- (A) Loading cylinder made from stainless steel
- (B) Inox-Radial heat exchanger made from stainless steel – for high operational reliability, a long service life and high heating output on a very small footprint
- (C) Modulating Matrix-Plus gas burner with intelligent Lambda Pro Plus combustion controller for extremely clean combustion and quiet operation
- (D) Integral diaphragm expansion vessel
- (E) Variable speed combustion air fan for quiet and economical operation
- (F) Plate heat exchanger
- (G) Hydraulics with integral, variable speed high efficiency circulation pump
- (H) Digital boiler control unit with black/white screen

Vitodens 222-W (cont.)

The Vitodens 222-W is a particularly space saving, wall mounted gas condensing storage combi boiler for situations where high DHW convenience is required. The heat cell comprises the proven stainless steel Inox-Radial heat exchanger, the modulating Matrix-Plus gas burner and the automatic Lambda Pro Control Plus combustion controller.

The integral 46 l stainless steel loading cylinder offers the same DHW convenience as a separate 150 l DHW cylinder with internal indirect coil. DHW is available immediately and constantly at the required temperature, even simultaneously at different draw-off points. In addition to the loading cylinder, all the most important system components, such as the heating water expansion vessel, pumps and safety valves, are integrated and fully fitted. All this – with a total weight of max. 68 kg and in a casing that fits into a standard 600 mm wide kitchen unit space.

Recommended applications

- Installation in detached and terraced houses
- New build (e.g. prefabricated houses and developer projects): Installation in utility rooms and attics
- Modernisation: Replacement of gas system boilers, floorstanding atmospheric gas boilers and oil/gas boilers with DHW cylinders installed below.
- Replacement of boilers in various types of systems, including those with several heating circuits and underfloor heating

Benefits at a glance

Control unit with 7-inch screen

- Seasonal central heating energy efficiency η_s up to 94 % (label A).
- Low cycle frequency, even with low heat demand, due to optimised pauses and a wide modulation range down to 1:17
- Durable and efficient thanks to Inox-Radial stainless steel heat exchanger
- Matrix-Plus gas burner with Lambda Pro Plus combustion controller for permanently high efficiency and clean combustion.
- Power saving, high efficiency circulation pump
- Colour touchscreen with plain text and graphic display, commissioning assistant, energy consumption indicators and the option of operation from a mobile device
- Web-enabled through integral WiFi interface for operation and service via Viessmann app

Benefits at a glance

Control unit with 3.5-inch screen

- Seasonal central heating energy efficiency η_s up to 94 % (label A).
- Low cycle frequency, even with low heat demand, due to optimised pauses and a wide modulation range down to 1:17

- Durable and efficient thanks to Inox-Radial stainless steel heat exchanger
- Matrix-Plus gas burner with Lambda Pro Plus combustion controller for permanently high efficiency and clean combustion.
- Power saving, high efficiency circulation pump
- Black/white screen with plain text and graphic display, commissioning assistant, energy consumption indicators and the option of operation from a mobile device
- Web-enabled through integral WiFi interface for operation and service via Viessmann app

Delivered condition

Gas condensing boiler with Inox-Radial heat exchanger, modulating Matrix-Plus gas burner for natural gas and LPG to DVGW Code of Practice G260 [Germany], expansion vessel, variable speed high efficiency circulation pump and integral stainless steel DHW loading cylinder. Fully plumbed and wired.

Weather-compensated or constant temperature control unit with integral WiFi interface.

White epoxy-coated casing.

Integral diaphragm expansion vessel (10 l capacity).

Integral refilling device for heating water.

Preset for operation with natural gas. Conversion within gas groups E/LL is not required. The conversion to LPG is made at the control unit (a conversion kit is not required).

Accessories required (order separately)

Pre-plumbing jig with:

- Fixings
- Valves/fittings
- DHW safety valve
- Boiler drain & fill valve
- Gas shut-off valve with thermally activated safety shut-off valve

For either surface or flush mounting

Tested quality

 CE designation according to current EU Directives

Meets the requirements for the "Blue Angel" ecolabel to RAL UZ 61.

2.2 Specification

Gas boiler, type B and C, category II _{2N3P}					
Type		B2LE			
Rated heating output range (to EN 15502-1) T _F /T _R = 50/30 °C					
Natural gas	kW	1.9 - 11.0	1.9 - 19.0	1.9 - 25.0	1.9 - 32.0
LPG	kW	2.5 - 11.0	2.5 - 19.0	2.5 - 25.0	2.5 - 32.0
T_F/T_R = 80/60 °C					
Natural gas	kW	1.7 - 10.1	1.7 - 17.4	1.7 - 22.9	1.7 - 29.3
LPG	kW	2.2 - 10.1	2.2 - 17.4	2.2 - 22.9	2.2 - 29.3
Rated heating output for DHW heating					
Natural gas	kW	1.7 - 21.8	1.7 - 26.2	1.7 - 30.4	1.7 - 33.5
LPG	kW	2.2 - 21.8	2.2 - 26.2	2.2 - 30.4	2.2 - 33.5
Rated heat input					
Natural gas	kW	1.8 - 22.7	1.8 - 27.3	1.8 - 31.7	1.8 - 34.9
LPG	kW	2.3 - 22.7	2.3 - 27.3	2.3 - 31.7	2.3 - 34.9
Product ID		CE-0085CT0017			
IP rating to EN 60529		IP X1			
Gas supply pressure					
Natural gas	mbar	20	20	20	20
	kPa	2	2	2	2
LPG	mbar	50	50	50	50
	kPa	5	5	5	5
Max. perm. gas supply pressure^{*5}					
Natural gas	mbar	25.0	25.0	25.0	25.0
	kPa	2.5	2.5	2.5	2.5
LPG	mbar	57.5	57.5	57.5	57.5
	kPa	5.75	5.75	5.75	5.75
Sound power level (to EN ISO 15036-1)					
- At partial load	dB(A)	32	32	32	32
- At rated heating output (DHW heating)	dB(A)	41	47	49	52
Power consumption in the delivered condition (incl. circulation pump)		W	37	47	68
Weight					
- Excl. heating water and DHW	kg	67.8	67.8	67.8	67.8
- Incl. heating water and DHW	kg	120.0	120.0	120.0	120.0
Water capacity (excl. diaphragm expansion vessel)		l	3.0	3.0	3.0
Max. flow temperature		°C	82	82	82
Max. flow rate (Limit for the use of hydraulic separation)		l/h	See residual head graphs		
Nominal circulating water volume At T _F /T _R = 80/60 °C		l/h	473	818	1076
Expansion vessel					
Capacity	l	10	10	10	10
Pre-charge pressure	bar	0.75	0.75	0.75	0.75
	kPa	75	75	75	75
Permiss. operating pressure		bar	3	3	3
	MPa	0.3	0.3	0.3	0.3
Connections (with connection accessories)					
Boiler flow and return	R	¾	¾	¾	¾
Cold water and DHW	G	½	½	½	½
Dimensions					
Length	mm	500	500	500	500
Width	mm	600	600	600	600
Height	mm	950	950	950	950
Gas connection (with connection accessories)		R	¾	¾	¾
DHW loading cylinder					
Capacity	l	46	46	46	46
Permiss. operating pressure (DHW side)	bar	10	10	10	10
	MPa	1	1	1	1

*5 If the gas supply pressure is higher than the maximum permissible value, install a separate gas pressure governor upstream of the system.

Vitodens 222-W (cont.)

Gas boiler, type B and C, category II _{2N3P}					
Type	B2LE				
Rated heating output range (to EN 15502-1)					
T _F /T _R = 50/30 °C					
Natural gas	kW	1.9 - 11.0	1.9 - 19.0	1.9 - 25.0	1.9 - 32.0
LPG	kW	2.5 - 11.0	2.5 - 19.0	2.5 - 25.0	2.5 - 32.0
T _F /T _R = 80/60 °C					
Natural gas	kW	1.7 - 10.1	1.7 - 17.4	1.7 - 22.9	1.7 - 29.3
LPG	kW	2.2 - 10.1	2.2 - 17.4	2.2 - 22.9	2.2 - 29.3
Continuous DHW output	kW	21.55	26.63	30.31	33.89
For DHW heating from 10 to 45 °C	l/h	526.8	643.2	726.6	813.6
Performance factor N _L *6		1.1	1.2	1.5	1.7
Initial DHW output	l/10 min	148.0	154.2	170.3	180.8
For DHW heating from 10 to 45 °C					
Supply values					
Relative to the max. load and 1013 mbar/15 °C					
Natural gas E	m ³ /h	2.40	2.89	3.35	3.69
Natural gas LL	m ³ /h	2.79	3.36	3.90	4.29
LPG	kg/h	1.76	2.12	2.46	2.71
Flue gas parameters					
Temperature (at a return temperature of 30 °C)					
– At rated heating output	°C	39	41	46	59
– At partial load	°C	38	38	38	38
Temperature (at a return temperature of 60 °C)					
	°C	67	70	74	77
Mass flow rate (for DHW heating)					
Natural gas					
– At rated heating output	kg/h	40.4	49.3	57.3	62.1
– At partial load	kg/h	3.2	3.2	3.2	3.2
LPG					
– At rated heating output	kg/h	39.8	49.2	57.1	61.1
– At partial load	kg/h	3.9	3.9	3.9	3.9
Available draught	Pa	250	250	250	250
	mbar	2.5	2.5	2.5	2.5
Max. amount of condensate	l/h	2.5	3.2	4.1	4.9
To DWA-A 251					
Condensate connection (hose nozzle)	Ø mm	20 - 24	20 - 24	20 - 24	20 - 24
Flue gas connection	Ø mm	60	60	60	60
Ventilation air connection	Ø mm	100	100	100	100
Standard seasonal efficiency [to DIN] at					
T _F /T _R = 40/30 °C	%	Up to 98 (H _s) [gross cv]			
Energy efficiency class					
– Heating		A	A	A	A
– DHW heating, draw-off profile XL		B	B	B	B

*6 At 70 °C average boiler water temperature and cylinder storage temperature T_{cyl} = 60 °C.

DHW performance factor N_L depends on cylinder storage temperature T_{cyl}.

Standard values: T_{cyl} = 60 °C → 1.0 × N_L T_{cyl} = 55 °C → 0.75 × N_L T_{cyl} = 50 °C → 0.55 × N_L T_{cyl} = 45 °C → 0.3 × N_L.

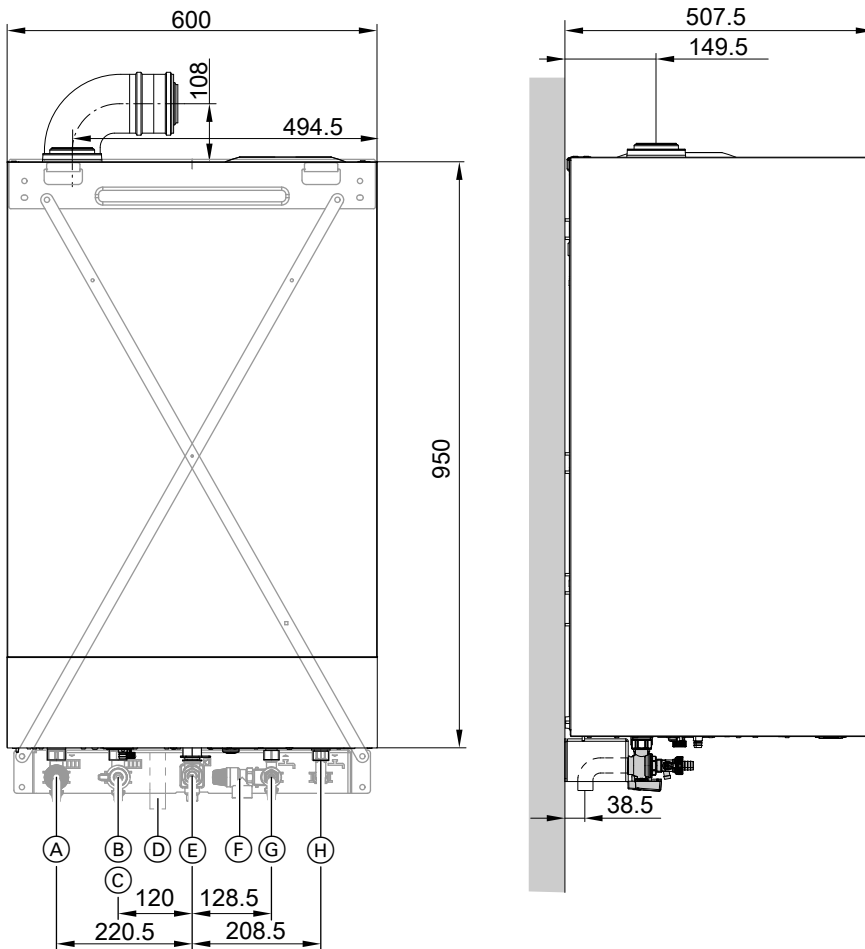

- (A) Heating flow
- (B) Heating return
- (C) Filling/drain
- (D) Condensate drain

- (E) Gas connection
- (F) Safety valve
- (G) Cold water
- (H) DHW

Note

For connection dimensions for surface mounting or flush mounting with the pre-plumbing jig, see page 71.

Note

The appliance is delivered fitted with a flexible power cable (2.0 m long). Lay the required power cables on site and route them into the boiler through the back.

Variable speed heating circuit pump in the Vitodens 222-W

The integral circulation pump is a highly efficient pump with substantially lower power consumption than conventional pumps. The pump speed and consequently the pump rate are regulated subject to the outside temperature and the switching times for heating mode or reduced mode. The control unit transmits the current speed specifications to the circulation pump via a PWM signal. The min. and max. speeds and the speed for reduced mode can be matched to the existing heating system via parameters at the control unit.

Setting (%) in the heating circuit 1 group:

- Min. speed: Parameter 1102.0
- Max. speed: Parameter 1102.1

- In the delivered condition, the minimum pump rate and the maximum pump rate are set to the following values:

Rated heating output in kW	Speed settings in the delivered condition in %	
	Min. pump rate	Max. pump rate
11	65	65
19	65	75
25	65	90
32	60	100

- In conjunction with a low loss header, heating water buffer cylinder and heating circuits with mixer, the internal circulation pump runs at a constant speed.

Vitodens 222-W (cont.)

Specification – circulation pump

Rated heating output	kW	11	19	25	32
Circulation pump	Type	UPM3 15-60	UPM3 15-60	UPM3 15-60	UPM3 15-75
Rated voltage	V~	230	230	230	230
Power consumption					
– Max.	W	42	42	42	60
– Min.	W	2	2	2	2
– Delivered condition	W	14.6	21.9	34.3	60
Energy efficiency class		A	A	A	A
Energy efficiency index (EEI)		≤ 0.20	≤ 0.20	≤ 0.20	≤ 0.20

Residual head of integral circulation pump

Rated heating output 11 to 25 kW

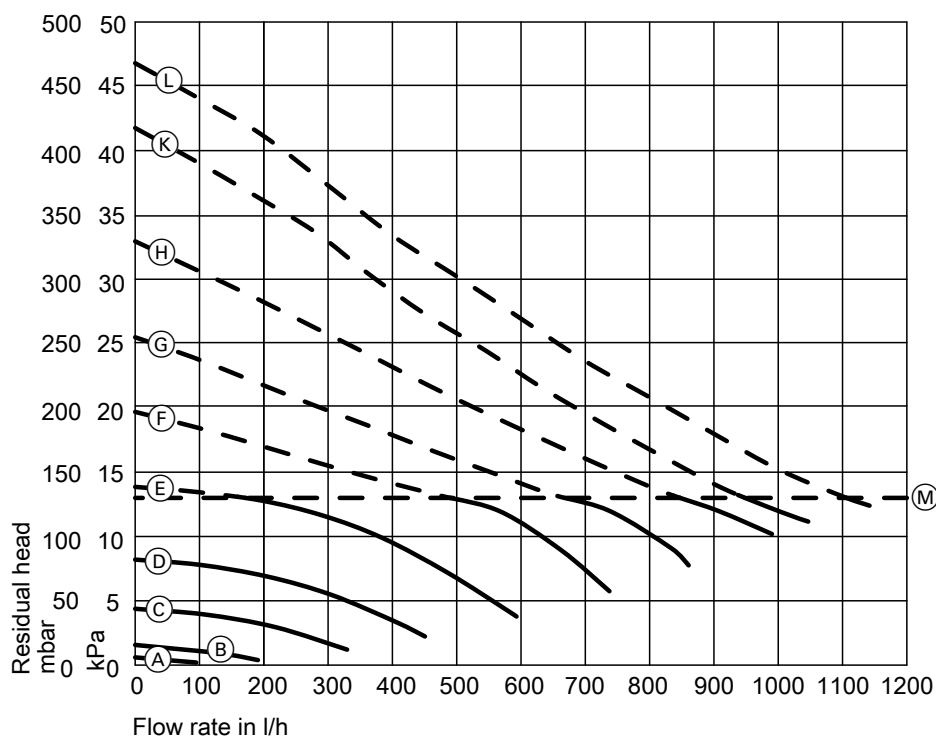

(M) Upper operational limit (integral bypass opens)

Curve	Pump rate, circulation pump
(A)	10 %
(B)	20 %
(C)	30 %
(D)	40 %
(E)	50 %
(F)	60 %
(G)	70 %
(H)	80 %
(K)	90 %
(L)	100 %

Vitodens 222-W (cont.)

Rated heating output 32 kW

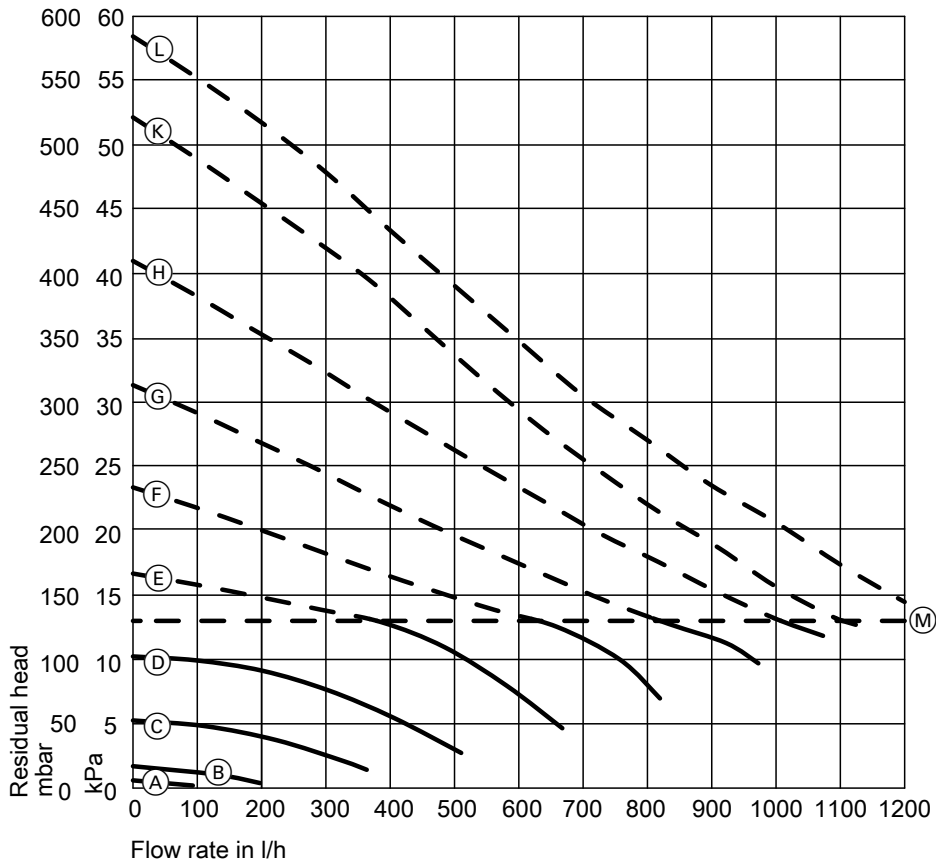

(M) Upper operational limit (integral bypass opens)

Curve	Pump rate, circulation pump
(A)	10 %
(B)	20 %
(C)	30 %
(D)	40 %
(E)	50 %
(F)	60 %
(G)	70 %
(H)	80 %
(K)	90 %
(L)	100 %

3.1 Product description

Control unit with 7-inch screen

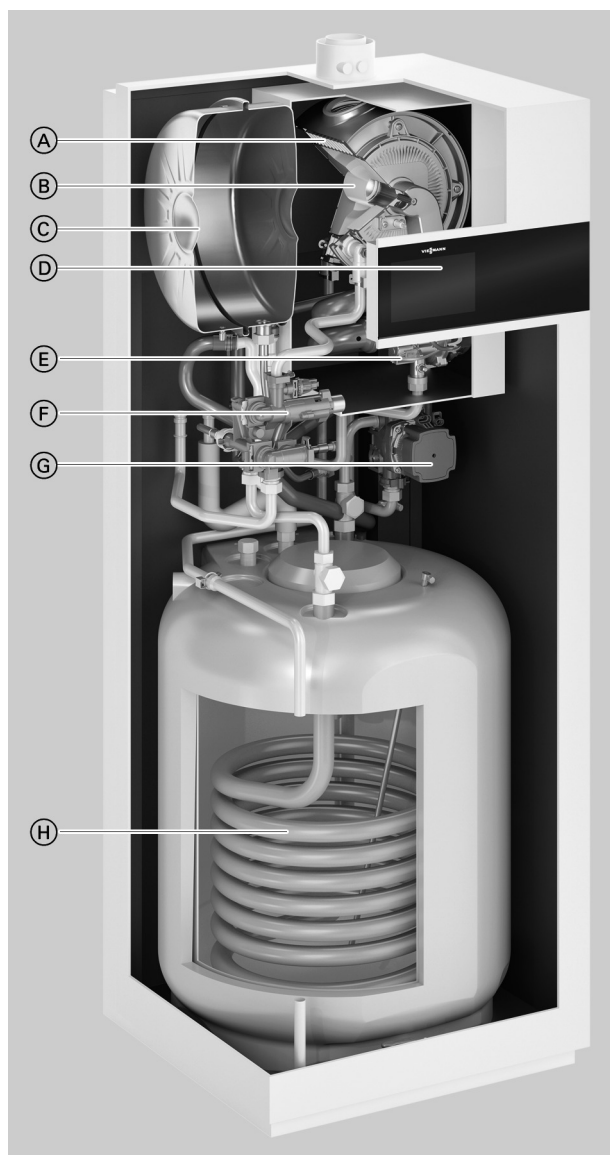

- Ⓐ Inox-Radial heat exchanger made from stainless steel – for high operational reliability, a long service life and high heating output on a very small footprint
- Ⓑ Modulating Matrix-Plus gas burner for extremely clean combustion
- Ⓒ Integral diaphragm expansion vessel
- Ⓓ Digital boiler control unit with colour touchscreen
- Ⓔ Variable speed combustion air fan for quiet and economical operation
- Ⓕ Hydraulics
- Ⓖ Integral, variable speed high efficiency circulation pump
- Ⓗ DHW cylinder

Vitodens 222-F, type B2SE (cont.)

Control unit with 3.5-inch screen

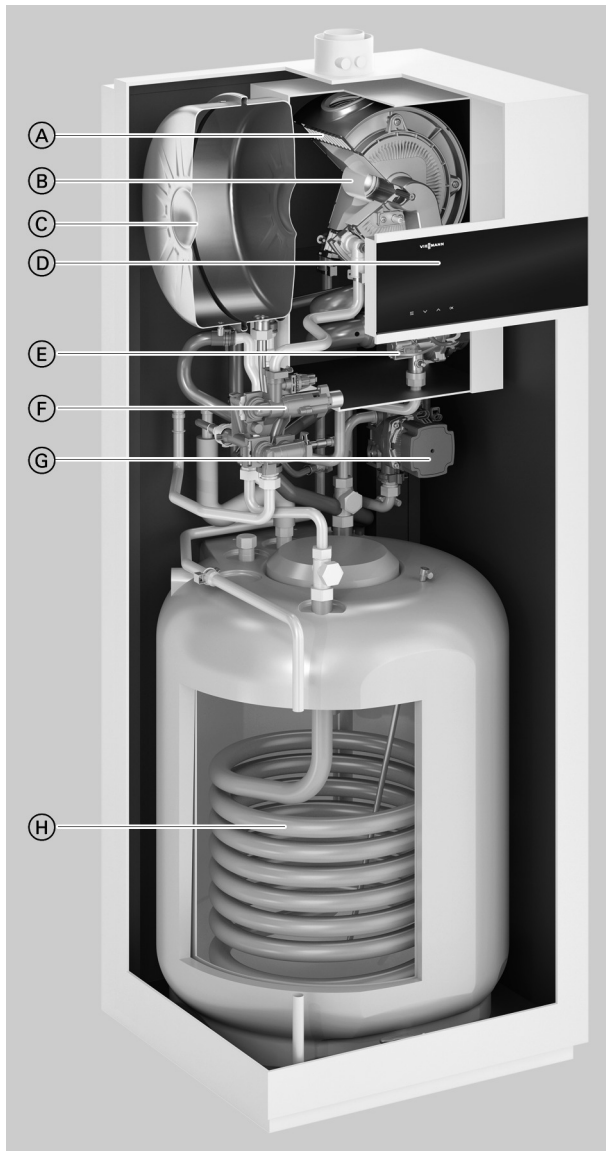

- Ⓐ Inox-Radial heat exchanger made from stainless steel – for high operational reliability, a long service life and high heating output on a very small footprint
- Ⓑ Modulating MatriX-Plus gas burner for extremely clean combustion
- Ⓒ Integral diaphragm expansion vessel
- Ⓓ Digital boiler control unit with black/white screen
- Ⓔ Variable speed combustion air fan for quiet and economical operation
- Ⓕ Hydraulics
- Ⓖ Integral, variable speed high efficiency circulation pump
- Ⓗ DHW cylinder

The Vitodens 222-F storage combi boiler combines the benefits of the Vitodens 200-W with the high level of DHW convenience of a separate DHW cylinder.

Fitted with the MatriX-Plus gas burner and stainless steel Inox-Radial heat exchanger, the Vitodens 222-F offers top technology for energy efficiency and a high level of heating and DHW convenience over the long term. The Lambda Pro Plus combustion controller and the variable speed high efficiency circulation pump ensure permanently high efficiency, reliable operation and low power consumption. The Vitodens 222-F, type B2SE with integral 130 l cylinder with indirect coil is particularly suitable for hard water areas.

Due to its smooth surface the indirect coil is resistant to limescale deposits.

Recommended applications

- Installation in detached and terraced houses
- New build (e.g. prefabricated houses and developer projects): Installation in utility rooms and attics
- Modernisation: Replacement of gas system boilers, floorstanding atmospheric gas boilers and oil/gas boilers with DHW cylinders installed below.
- Replacement of boilers in various types of systems, including those with several heating circuits and underfloor heating

Benefits at a glance

Control unit with 7-inch screen

- Seasonal central heating energy efficiency η_s up to 94 % (label A).
- Low cycle frequency, even with low heat demand, due to optimised pauses and a wide modulation range down to 1:17
- Durable and efficient thanks to Inox-Radial stainless steel heat exchanger
- MatriX-Plus gas burner with Lambda Pro Plus combustion controller for permanently high efficiency and clean combustion.
- Power saving, high efficiency circulation pump
- Colour touchscreen with plain text and graphic display, commissioning assistant, energy consumption indicators and the option of operation from a mobile device
- Web-enabled through integral WiFi interface for operation and service via Viessmann app
- Assembly kit (accessories) with same dimensions and design as the boiler, for the connection of one regulated and one unregulated heating circuit

Vitodens 222-F, type B2SE (cont.)

Benefits at a glance

Control unit with 3.5-inch screen

- Seasonal central heating energy efficiency η_s up to 94 % (label A).
- Low cycle frequency, even with low heat demand, due to optimised pauses and a wide modulation range down to 1:17
- Durable and efficient thanks to Inox-Radial stainless steel heat exchanger
- MatriX-Plus gas burner with Lambda Pro Plus combustion controller for permanently high efficiency and clean combustion.
- Power saving, high efficiency circulation pump
- Black/white screen with plain text and graphic display, commissioning assistant, energy consumption indicators and the option of operation from a mobile device
- Web-enabled through integral WiFi interface for operation and service via Viessmann app
- Assembly kit (accessories) with same dimensions and design as the boiler, for the connection of one regulated and one unregulated heating circuit

Delivered condition

Gas condensing boiler with Inox-Radial heat exchanger, modulating MatriX-Plus gas burner for natural gas and LPG to DVGW Code of Practice G260 [Germany], expansion vessel, variable speed high efficiency circulation pump and integral DHW cylinder. Fully plumbed and wired.

Weather-compensated or constant temperature control unit with integral WiFi interface.

White epoxy-coated casing.

Integral diaphragm expansion vessel (18 l capacity).

Preset for operation with natural gas. Conversion within gas groups E/LL is not required. The conversion to LPG is made at the control unit (a conversion kit is not required).

Accessories required (order separately)

Surface mounting

- Connection set for surface mounting; upward connection or
- Connection set for surface mounting; connection to the left or right or
- Assembly kit with mixer

Flush mounting

- Connection set for flush mounting

Tested quality

 CE designation according to current EU Directives

Meets the requirements for the "Blue Angel" ecolabel to RAL UZ 61.

3.2 Specification

Gas boiler, type B and C, category II _{2N3P}					
Type		B2SE			
Rated heating output range (details to EN 15502)					
T _F /T _R = 50/30 °C					
Natural gas	kW	1.9 - 11.0	1.9 - 19.0	1.9 - 25.0	1.9 - 32.0
LPG	kW	2.5 - 11.0	2.5 - 19.0	2.5 - 25.0	2.5 - 32.0
T _F /T _R = 80/60 °C					
Natural gas	kW	1.7 - 10.1	1.7 - 17.4	1.7 - 22.9	1.7 - 29.3
LPG	kW	2.2 - 10.1	2.2 - 17.4	2.2 - 22.9	2.2 - 29.3
Rated heating output for DHW heating					
Natural gas	kW	1.7 - 17.4	1.7 - 21.8	1.7 - 28.3	1.7 - 33.5
LPG	kW	2.2 - 17.4	2.2 - 21.8	2.2 - 28.3	2.2 - 33.5
Rated heat input					
Natural gas	kW	1.8 - 18.1	1.8 - 22.7	1.8 - 29.5	1.8 - 35.3
LPG	kW	2.3 - 18.1	2.3 - 22.7	2.3 - 29.5	2.3 - 34.9
Product ID		CE-0085CT0017			
IP rating to EN 60529		IP X4			
– In conjunction with assembly kit (accessories)		IP X1			
Gas supply pressure					
Natural gas	mbar	20	20	20	20
	kPa	2	2	2	2
LPG	mbar	50	50	50	50
	kPa	5	5	5	5
Max. perm. gas supply pressure^{*7}					
Natural gas	mbar	25.0	25.0	25.0	25.0
	kPa	2.5	2.5	2.5	2.5
LPG	mbar	57.5	57.5	57.5	57.5
	kPa	5.75	5.75	5.75	5.75
Sound power level (to EN ISO 15036-1)					
– At partial load		dB(A)	32	32	32
– At rated heating output (DHW heating)		dB(A)	41	47	52
Power consumption in the delivered condition (incl. circulation pump)		W	37	54	68
Weight					
– Excl. heating water and DHW		kg	132	132	132
– Incl. heating water and DHW		kg			
Heating water capacity (excl. diaphragm expansion vessel)		l	3.0	3.0	3.0
Max. flow temperature		°C	82	82	82
Max. flow rate (Limit for the use of hydraulic separation)		l/h	See residual head graphs		
Nominal circulating water volume At T _F /T _R = 80/60 °C		l/h	473	818	1076
Expansion vessel					
Capacity		l	18	18	18
Pre-charge pressure		bar	0.75	0.75	0.75
		kPa	75	75	75
Permiss. operating pressure		bar	3	3	3
		MPa	0.3	0.3	0.3
Connections (with connection accessories)					
Boiler flow and return		R	¾	¾	¾
Cold water and DHW		R	½	½	½
DHW circulation		R	½	½	½
Dimensions					
Length		mm	595	595	595
Width		mm	600	600	600
Height		mm	1600	1600	1600
Gas connection (with connection accessories)		R	½	½	½

^{*7} If the gas supply pressure is higher than the maximum permissible value, install a separate gas pressure governor upstream of the system.

Vitodens 222-F, type B2SE (cont.)

Gas boiler, type B and C, category II _{2N3P}					
Type	B2SE				
Rated heating output range (details to EN 15502)					
T _F /T _R = 50/30 °C					
Natural gas	kW	1.9 - 11.0	1.9 - 19.0	1.9 - 25.0	1.9 - 32.0
LPG	kW	2.5 - 11.0	2.5 - 19.0	2.5 - 25.0	2.5 - 32.0
T _F /T _R = 80/60 °C					
Natural gas	kW	1.7 - 10.1	1.7 - 17.4	1.7 - 22.9	1.7 - 29.3
LPG	kW	2.2 - 10.1	2.2 - 17.4	2.2 - 22.9	2.2 - 29.3
DHW cylinder					
Capacity	l	130	130	130	130
Permiss. operating pressure (DHW side)	bar	10	10	10	10
	MPa	1	1	1	1
Continuous DHW output	kW	17.11	21.30	24.00	25.01
For DHW heating from 10 to 45 °C	l/h	418.80	515.40	586.80	612.00
Performance factor N _L *8		1.4	1.5	1.7	1.7
Initial DHW output	l/10 min	167.00	170.30	179.50	179.90
For DHW heating from 10 to 45 °C					
Supply values					
Relative to the max. load and 1013 mbar/15 °C					
Natural gas E	m ³ /h	1.92	2.40	3.12	3.69
Natural gas LL	m ³ /h	2.23	2.79	3.63	4.29
LPG	kg/h	1.41	1.76	2.29	2.71
Flue gas parameters					
Temperature (at a return temperature of 30 °C)					
– At rated heating output	°C	39	41	46	59
– At partial load	°C	38	38	38	38
Temperature (at a return temperature of 60 °C)					
	°C	65	67	72	77
Mass flow rate (for DHW heating)					
Natural gas					
– At rated heating output	kg/h	32.2	40.4	54.2	62.1
– At partial load	kg/h	3.2	3.2	3.2	3.2
LPG					
– At rated heating output	kg/h	30.6	39.8	53.2	61.1
– At partial load	kg/h	3.9	3.9	3.9	3.9
Available draught	Pa	250	250	250	250
	mbar	2.5	2.5	2.5	2.5
Max. amount of condensate	l/h	2.5	3.2	4.1	4.9
To DWA-A 251					
Condensate connection (hose nozzle)	Ø mm	20 - 24	20 - 24	20 - 24	20 - 24
Flue gas connection	Ø mm	60	60	60	60
Ventilation air connection	Ø mm	100	100	100	100
Standard seasonal efficiency [to DIN] at					
T _F /T _R = 40/30 °C	%	Up to 98 (H _s) [gross cv]			
Energy efficiency class					
– Heating		A	A	A	A
– DHW heating, draw-off profile XL		B	B	B	B

*8 At 70 °C average boiler water temperature and cylinder storage temperature T_{cyl} = 60 °C.

DHW performance factor N_L depends on cylinder storage temperature T_{cyl}.

Standard values: T_{cyl} = 60 °C → 1.0 × N_L T_{cyl} = 55 °C → 0.75 × N_L T_{cyl} = 50 °C → 0.55 × N_L T_{cyl} = 45 °C → 0.3 × N_L.

Vitodens 222-F, type B2SE (cont.)

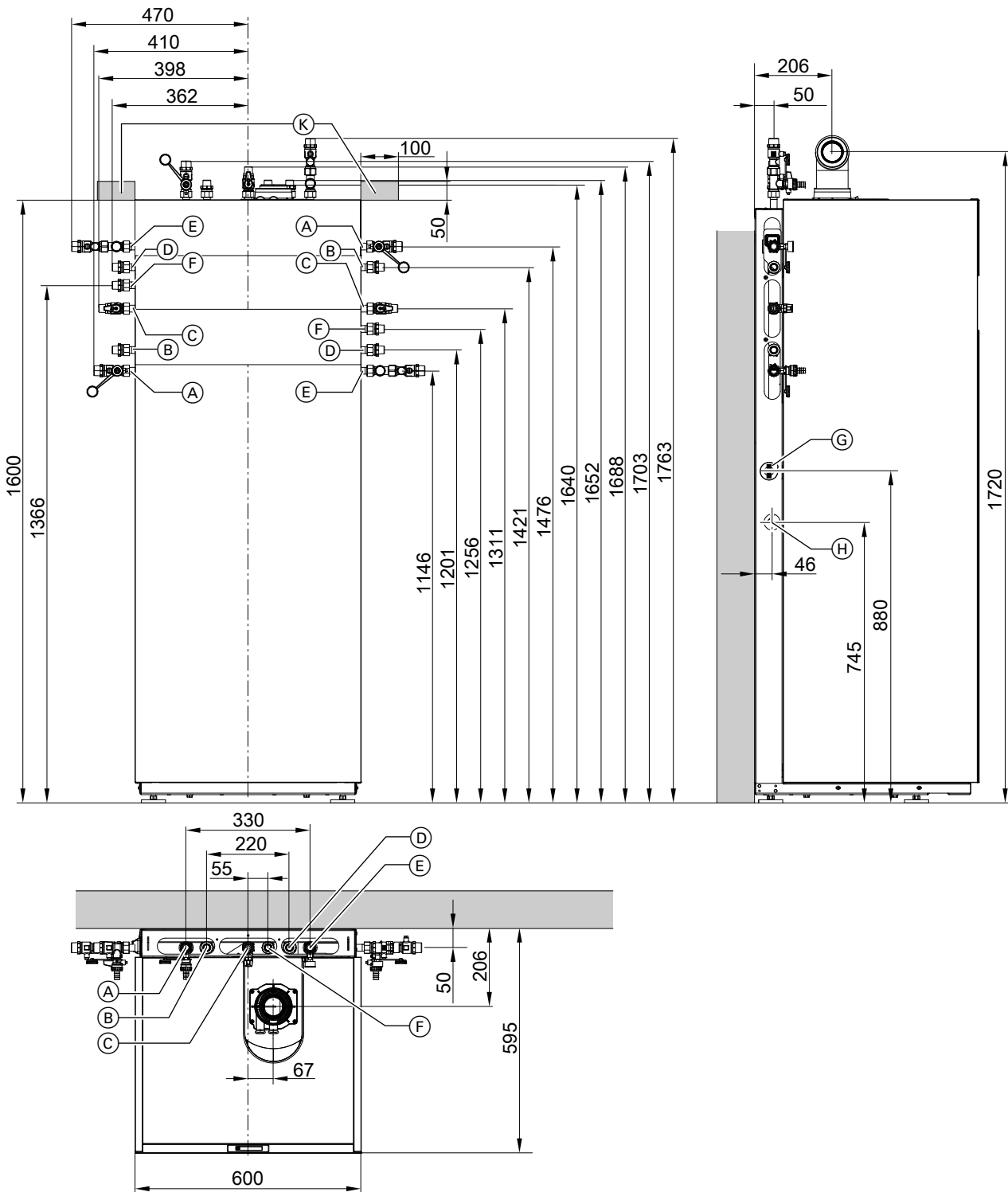

- (A) Heating flow R ¼
- (B) DHW R ½
- (C) Gas connection R ½
- (D) Cold water R ½
- (E) Heating return R ¼
- (F) DHW circulation R ½ (separate accessories)
- (G) External plug
- (H) Condensate drain to the side
- (K) Area for electrical cables (on-site junction box)

Note

The dimensioned drawing shows an example of valves/fittings for surface mounting, upward connection and connection to the left/right.

Order the connection sets separately as accessories.

Note

The appliance is delivered fitted with a flexible power cable (1.5 m long). Lay the required power cables on site and route them into the boiler through the back.

5853906

Vitodens 222-F, type B2SE (cont.)

Note

All height dimensions have a tolerance of +15 mm on account of the adjustable feet.

Variable speed heating circuit pump in the Vitodens 222-F

The integral circulation pump is a highly efficient pump with substantially lower power consumption than conventional pumps.

The pump speed and consequently the pump rate are regulated subject to the outside temperature and the switching times for heating mode or reduced mode. The control unit transmits the current speed specifications to the circulation pump via a PWM signal.

The min. and max. speeds and the speed for reduced mode can be matched to the existing heating system via parameters at the control unit.

Setting (%) in the heating circuit 1 group:

- Min. speed: Parameter 1102.0
- Max. speed: Parameter 1102.1

- In the delivered condition, the minimum pump rate and the maximum pump rate are set to the following values:

Rated heating output in kW	Speed settings in the delivered condition in %	
	Min. pump rate	Max. pump rate
11	65	65
19	65	80
25	65	100
32	60	100

- In conjunction with a low loss header, heating water buffer cylinder and heating circuits with mixer, the internal circulation pump runs at a constant speed.

Siting information

Site the Vitodens 222-F with its back flush against the wall.

Specification – circulation pump

Rated heating output	kW	11	19	25	32
Circulation pump	Type	UPM3 15-60	UPM3 15-60	UPM3 15-60	UPM3 15-75
Rated voltage	V~	230	230	230	230
Power consumption					
– Max.	W	42	42	42	60
– Min.	W	2	2	2	2
– Delivered condition	W	14.6	28.1	42.0	60.0
Energy efficiency class		A	A	A	A
Energy efficiency index (EEI)		≤ 0.20	≤ 0.20	≤ 0.20	≤ 0.20

Vitodens 222-F, type B2SE (cont.)

Residual head of integral circulation pump

Rated heating output 11 to 25 kW

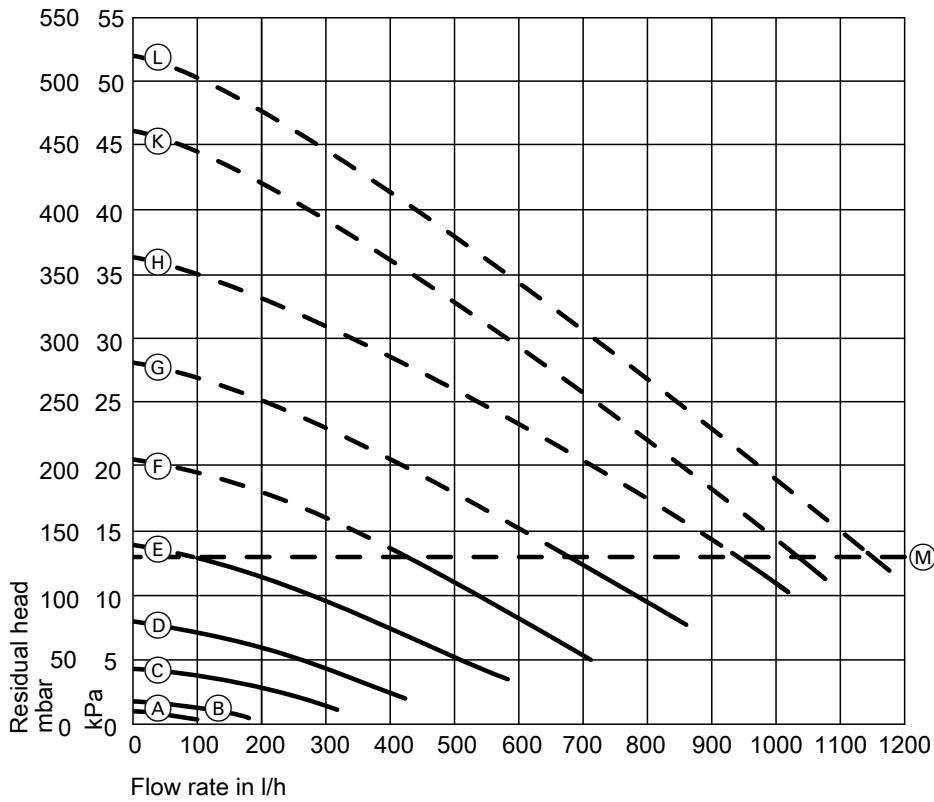

(M) Upper operational limit (integral bypass opens)

Curve	Pump rate, circulation pump
(A)	10 %
(B)	20 %
(C)	30 %
(D)	40 %
(E)	50 %
(F)	60 %
(G)	70 %
(H)	80 %
(K)	90 %
(L)	100 %

Vitodens 222-F, type B2SE (cont.)

Rated heating output 32 kW

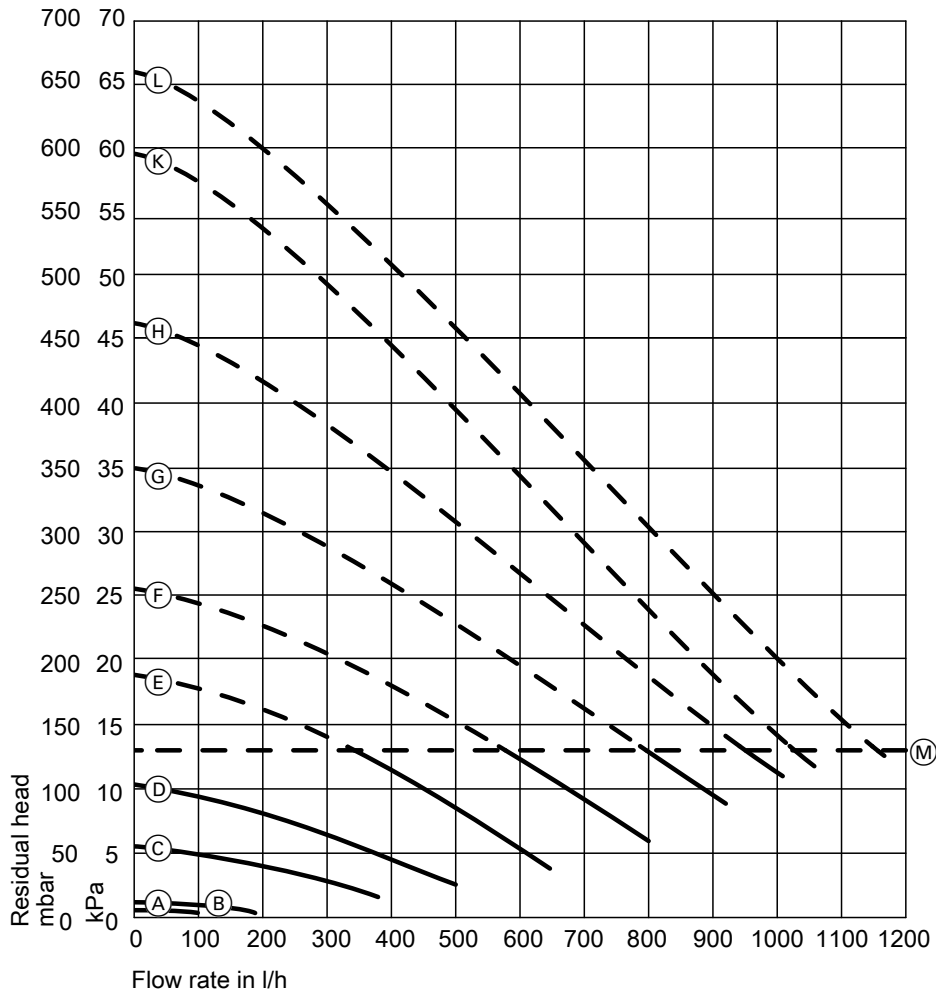

(M) Upper operational limit (integral bypass opens)

Curve	Pump rate, circulation pump
(A)	10 %
(B)	20 %
(C)	30 %
(D)	40 %
(E)	50 %
(F)	60 %
(G)	70 %
(H)	80 %
(K)	90 %
(L)	100 %

3

4.1 Product description

Control unit with 7-inch screen

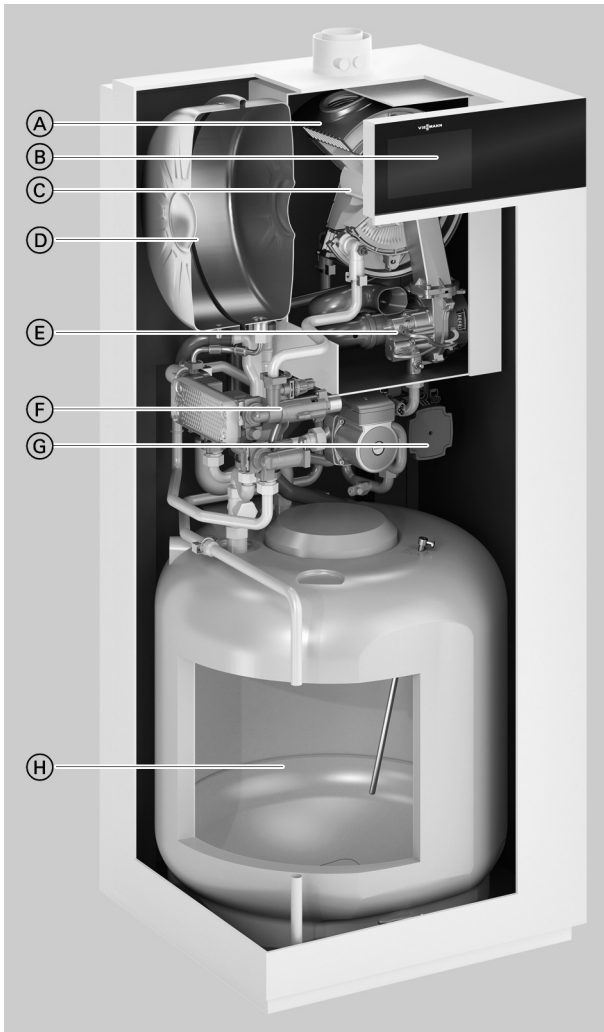

- Ⓐ Inox-Radial heat exchanger made from stainless steel – for high operational reliability, a long service life and high heating output on a very small footprint
- Ⓑ Digital boiler control unit with colour touchscreen
- Ⓒ Modulating MatriX-Plus gas burner for extremely clean combustion
- Ⓓ Integral diaphragm expansion vessel
- Ⓔ Variable speed combustion air fan for quiet and economical operation
- Ⓕ Hydraulics
- Ⓖ Integral, variable speed high efficiency circulation pump
- Ⓗ DHW loading cylinder

Vitodens 222-F, type B2TE (cont.)

Control unit with 3.5-inch screen

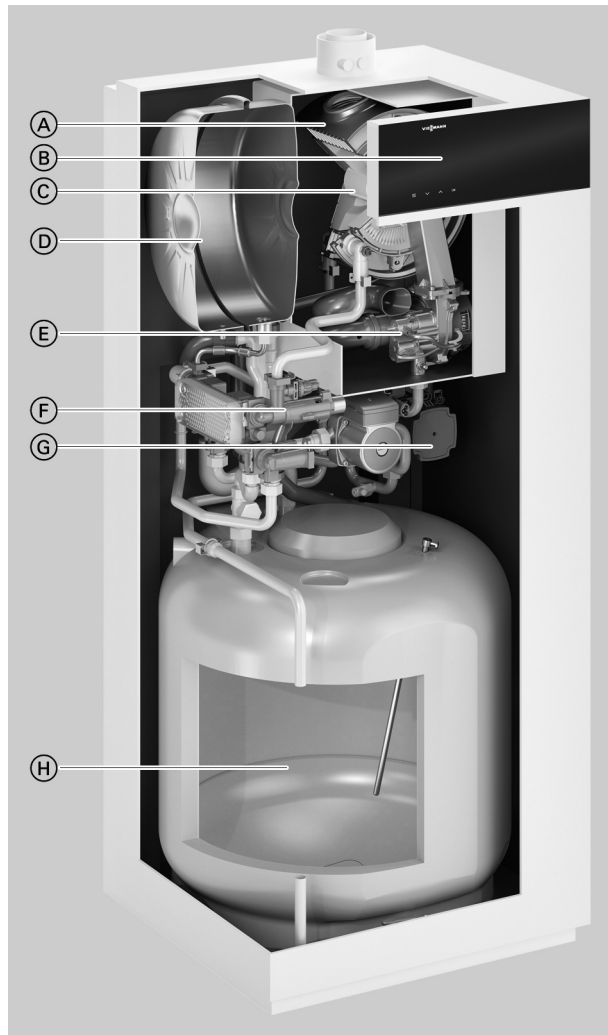

- Ⓐ Inox-Radial heat exchanger made from stainless steel – for high operational reliability, a long service life and high heating output on a very small footprint
- Ⓑ Digital boiler control unit with black/white screen
- Ⓒ Modulating MatriX-Plus gas burner for extremely clean combustion
- Ⓓ Integral diaphragm expansion vessel
- Ⓔ Variable speed combustion air fan for quiet and economical operation
- Ⓕ Hydraulics
- Ⓖ Integral, variable speed high efficiency circulation pump
- Ⓗ DHW loading cylinder

The Vitodens 222-F storage combi boiler combines the benefits of the Vitodens 200-W with the high level of DHW convenience of a separate DHW cylinder.

Fitted with the MatriX-Plus gas burner and stainless steel Inox-Radial heat exchanger, the Vitodens 222-F offers top technology for energy efficiency and a high level of heating and DHW convenience over the long term. The Lambda Pro Plus combustion controller and the variable speed high efficiency circulation pump ensure permanently high efficiency, reliable operation and low power consumption. The integral DHW loading cylinder with 100 l capacity offers the same DHW convenience as a separate DHW cylinder approximately twice the size.

Recommended applications

- Installation in detached and terraced houses
- New build (e.g. prefabricated houses and developer projects):
Installation in utility rooms and attics
- Modernisation: Replacement of gas system boilers, floorstanding atmospheric gas boilers and oil/gas boilers with DHW cylinders installed below.
- Replacement of boilers in various types of systems, including those with several heating circuits and underfloor heating

Benefits at a glance

Control unit with 7-inch screen

- Seasonal central heating energy efficiency η_S up to 94 % (label A).
- Low cycle frequency, even with low heat demand, due to optimised pauses and a wide modulation range down to 1:17
- Durable and efficient thanks to Inox-Radial stainless steel heat exchanger
- MatriX-Plus gas burner with Lambda Pro Plus combustion controller for permanently high efficiency and clean combustion.
- Power saving, high efficiency circulation pump
- Colour touchscreen with plain text and graphic display, commissioning assistant, energy consumption indicators and the option of operation from a mobile device
- Web-enabled through integral WiFi interface for operation and service via Viessmann app
- Assembly kit (accessories) with same dimensions and design as the boiler, for the connection of one regulated and one unregulated heating circuit

Benefits at a glance

Control unit with 3.5-inch screen

- Seasonal central heating energy efficiency η_S up to 94 % (label A).
- Low cycle frequency, even with low heat demand, due to optimised pauses and a wide modulation range down to 1:17
- Durable and efficient thanks to Inox-Radial stainless steel heat exchanger



Vitodens 222-F, type B2TE (cont.)

- MatriX-Plus gas burner with Lambda Pro Plus combustion controller for permanently high efficiency and clean combustion.
- Power saving, high efficiency circulation pump
- Black/white screen with plain text and graphic display, commissioning assistant, energy consumption indicators and the option of operation from a mobile device
- Web-enabled through integral WiFi interface for operation and service via Viessmann app
- Assembly kit (accessories) with same dimensions and design as the boiler, for the connection of one regulated and one unregulated heating circuit

Delivered condition

Gas condensing boiler with Inox-Radial heat exchanger, modulating MatriX-Plus gas burner for natural gas and LPG to DVGW Code of Practice G260 [Germany], expansion vessel, variable speed high efficiency circulation pump and integral DHW loading cylinder. Fully plumbed and wired.

Weather-compensated or constant temperature control unit with integral WiFi interface.

White epoxy-coated casing.

Integral diaphragm expansion vessel (18 l capacity).

Preset for operation with natural gas. Conversion within gas groups E/LL is not required. The conversion to LPG is made at the control unit (a conversion kit is not required).

Accessories required (order separately)

Surface mounting

- Connection set for surface mounting; upward connection or
- Connection set for surface mounting; connection to the left or right or
- Assembly kit with mixer

Flush mounting

- Connection set for flush mounting

Tested quality

 CE designation according to current EU Directives

Meets the requirements for the "Blue Angel" ecolabel to RAL UZ 61.

4.2 Specification

Gas boiler, type B and C, category II _{2N3P}		B2TE		
Type		B2TE		
Rated heating output range (details to EN 15502)				
T _F /T _R = 50/30 °C				
Natural gas	kW	1.9 - 19.0	1.9 - 25.0	1.9 - 32.0
LPG	kW	2.5 - 19.0	2.5 - 25.0	2.5 - 32.0
T _F /T _R = 80/60 °C				
Natural gas	kW	1.7 - 17.4	1.7 - 22.9	1.7 - 29.3
LPG	kW	2.2 - 17.4	2.2 - 22.9	2.2 - 29.3
Rated heating output for DHW heating				
Natural gas	kW	1.7 - 21.8	1.7 - 28.3	1.7 - 33.5
LPG	kW	2.2 - 21.8	2.2 - 28.3	2.2 - 33.5
Rated heat input				
Natural gas	kW	1.8 - 22.7	1.8 - 29.5	1.8 - 34.9
LPG	kW	2.3 - 22.7	2.3 - 29.5	2.3 - 34.9
Product ID		CE-0085CT0017		
IP rating to EN 60529		IP X4		
– In conjunction with assembly kit (accessories)		IP X1		
Gas supply pressure				
Natural gas	mbar	20	20	20
	kPa	2	2	2
LPG	mbar	50	50	50
	kPa	5	5	5
Max. permitt. gas supply pressure^{*9}				
Natural gas	mbar	25.0	25.0	25.0
	kPa	2.5	2.5	2.5
LPG	mbar	57.5	57.5	57.5
	kPa	5.75	5.75	5.75
Sound power level				
(to EN ISO 15036-1)				
– At partial load	dB(A)	32	32	32
– At rated heating output (DHW heating)	dB(A)	47	49	52
Power consumption in the delivered condition (incl. circulation pump)		W	54	68
Weight				
– Excl. heating water and DHW	kg	111.5	111.5	111.5
– Incl. heating water and DHW	kg			
Water capacity (excl. diaphragm expansion vessel)		l	3.0	3.0
Max. flow temperature		°C	82	82
Max. flow rate		l/h	See residual head graphs	
Nominal circulating water volume		l/h	818	1076
At T _F /T _R = 80/60 °C				
Expansion vessel				
Capacity	l	18	18	18
Pre-charge pressure	bar	0.75	0.75	0.75
	kPa	75	75	75
Permitt. operating pressure		bar	3	3
	MPa	0.3	0.3	0.3
Connections (with connection accessories)				
Boiler flow and return	R	¾	¾	¾
Cold water and DHW	R	½	½	½
DHW circulation	R	½	½	½
Dimensions				
Length	mm	595	595	595
Width	mm	600	600	600
Height	mm	1400	1400	1400
Gas connection (with connection accessories)		R	½	½

*9 If the gas supply pressure is higher than the maximum permissible value, install a separate gas pressure governor upstream of the system.

Vitodens 222-F, type B2TE (cont.)

Gas boiler, type B and C, category II _{2N3P}		B2TE		
Type		B2TE		
Rated heating output range (details to EN 15502)				
T _F /T _R = 50/30 °C				
Natural gas	kW	1.9 - 19.0	1.9 - 25.0	1.9 - 32.0
LPG	kW	2.5 - 19.0	2.5 - 25.0	2.5 - 32.0
T _F /T _R = 80/60 °C				
Natural gas	kW	1.7 - 17.4	1.7 - 22.9	1.7 - 29.3
LPG	kW	2.2 - 17.4	2.2 - 22.9	2.2 - 29.3
DHW loading cylinder				
Capacity	l	100	100	100
Permiss. operating pressure (DHW side)	bar	10	10	10
	MPa	1	1	1
Continuous DHW output	kW	19.74	26.53	32.50
For DHW heating from 10 to 45 °C	l/h	484.80	648.80	793.80
Performance factor N _L *10		1.4	2.1	2.6
Initial DHW output	l/10 min	163.70	196.20	215.50
For DHW heating from 10 to 45 °C				
Supply values				
Relative to the max. load and 1013 mbar/15 °C				
Natural gas E	m ³ /h	2.40	3.12	3.69
Natural gas LL	m ³ /h	2.79	3.63	4.29
LPG	kg/h	1.76	2.29	2.71
Flue gas parameters				
Temperature (at a return temperature of 30 °C)				
– At rated heating output	°C	41	46	59
– At partial load	°C	38	38	38
Temperature (at a return temperature of 60 °C)				
	°C	67	72	77
Mass flow rate (for DHW heating)				
Natural gas				
– At rated heating output	kg/h	40.4	54.2	62.1
– At partial load	kg/h	3.2	3.2	3.2
LPG				
– At rated heating output	kg/h	39.8	53.2	61.1
– At partial load	kg/h	3.9	3.9	3.9
Available draught	Pa	250	250	250
	mbar	2.5	2.5	2.5
Max. amount of condensate	l/h	3.2	4.1	4.9
To DWA-A 251				
Condensate connection (hose nozzle)	Ø mm	20 - 24	20 - 24	20 - 24
Flue gas connection	Ø mm	60	60	60
Ventilation air connection	Ø mm	100	100	100
Standard seasonal efficiency [to DIN] at				
T _F /T _R = 40/30 °C	%	Up to 98 (H _s) [gross cv]		
Energy efficiency class				
– Heating		A	A	A
– DHW heating, draw-off profile XL		A	A	A

5853906 *10 At 70 °C average boiler water temperature and cylinder storage temperature T_{cyl} = 60 °C.
DHW performance factor N_L depends on cylinder storage temperature T_{cyl}.
Standard values: T_{cyl} = 60 °C → 1.0 × N_L T_{cyl} = 55 °C → 0.75 × N_L T_{cyl} = 50 °C → 0.55 × N_L T_{cyl} = 45 °C → 0.3 × N_L.

Vitodens 222-F, type B2TE (cont.)

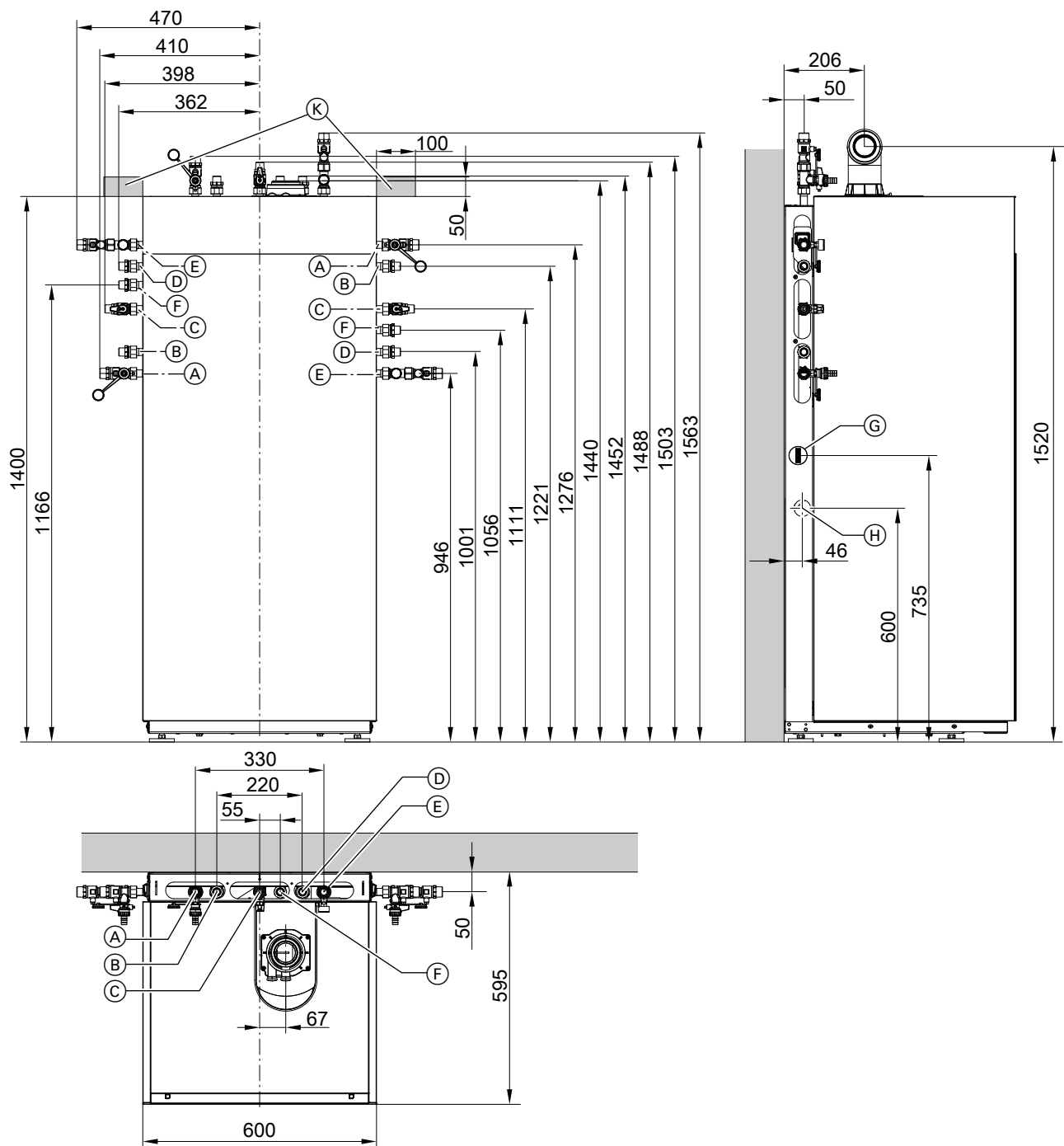

- (A) Heating flow R $\frac{3}{4}$
- (B) DHW R $\frac{1}{2}$
- (C) Gas connection R $\frac{1}{2}$
- (D) Cold water R $\frac{1}{2}$
- (E) Heating return R $\frac{3}{4}$
- (F) DHW circulation R $\frac{1}{2}$ (separate accessories)
- (G) External plug
- (H) Condensate drain to the side
- (K) Area for electrical cables (on-site junction box)

Note

The dimensioned drawing shows an example of valves/fittings for surface mounting, upward connection and connection to the left/right.

Order the connection sets separately as accessories.

Note

The appliance is delivered fitted with a flexible power cable (1.5 m long). Lay the required power cables on site and route them into the boiler through the back.

Note

All height dimensions have a tolerance of +15 mm on account of the adjustable feet.

Siting information

Site the Vitodens 222-F with its back flush against the wall.

Vitodens 222-F, type B2TE (cont.)

Variable speed heating circuit pump in the Vitodens 222-F

The integral circulation pump is a highly efficient pump with substantially lower power consumption than conventional pumps. The pump speed and consequently the pump rate are regulated subject to the outside temperature and the switching times for heating mode or reduced mode. The control unit transmits the current speed specifications to the circulation pump via a PWM signal. The min. and max. speeds and the speed for reduced mode can be matched to the existing heating system via parameters at the control unit.

Setting (%) in the heating circuit 1 group:

- Min. speed: Parameter 1102.0
- Max. speed: Parameter 1102.1

- In the delivered condition, the minimum pump rate and the maximum pump rate are set to the following values:

Rated heating output in kW	Speed settings in the delivered condition in %	
	Min. pump rate	Max. pump rate
19	65	80
25	65	100
32	60	100

- In conjunction with a low loss header, heating water buffer cylinder and heating circuits with mixer, the internal circulation pump runs at a constant speed.

Residual head of integral circulation pump

Rated heating output 19 to 25 kW

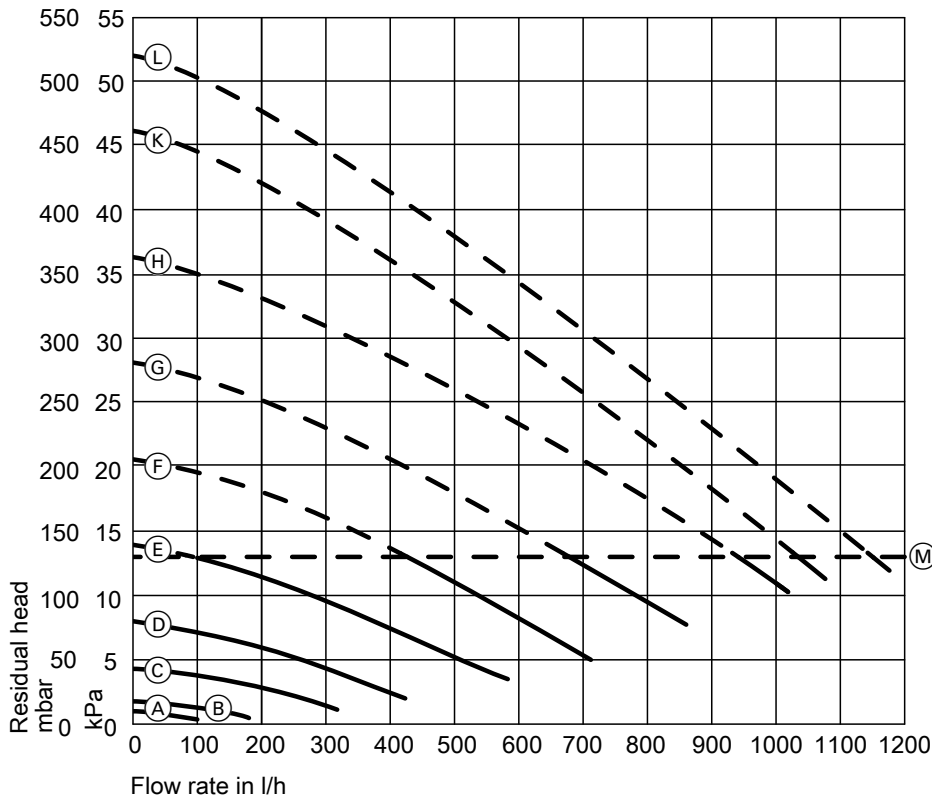

Ⓜ Upper operational limit (integral bypass opens)

Specification – circulation pump

Rated heating output	kW	19	25	32
Circulation pump	Type	UPM3 15-60	UPM3 15-60	UPM3 15-75
Rated voltage	V~	230	230	230
Power consumption				
– Max.	W	42	42	60
– Min.	W	2	2	2
– Delivered condition	W	28.1	42	60
Energy efficiency class		A	A	A
Energy efficiency index (EEI)		≤ 0.20	≤ 0.20	≤ 0.20

Vitodens 222-F, type B2TE (cont.)

Curve	Pump rate, circulation pump
(A)	10 %
(B)	20 %
(C)	30 %
(D)	40 %
(E)	50 %
(F)	60 %
(G)	70 %
(H)	80 %
(K)	90 %
(L)	100 %

Rated heating output 32 kW

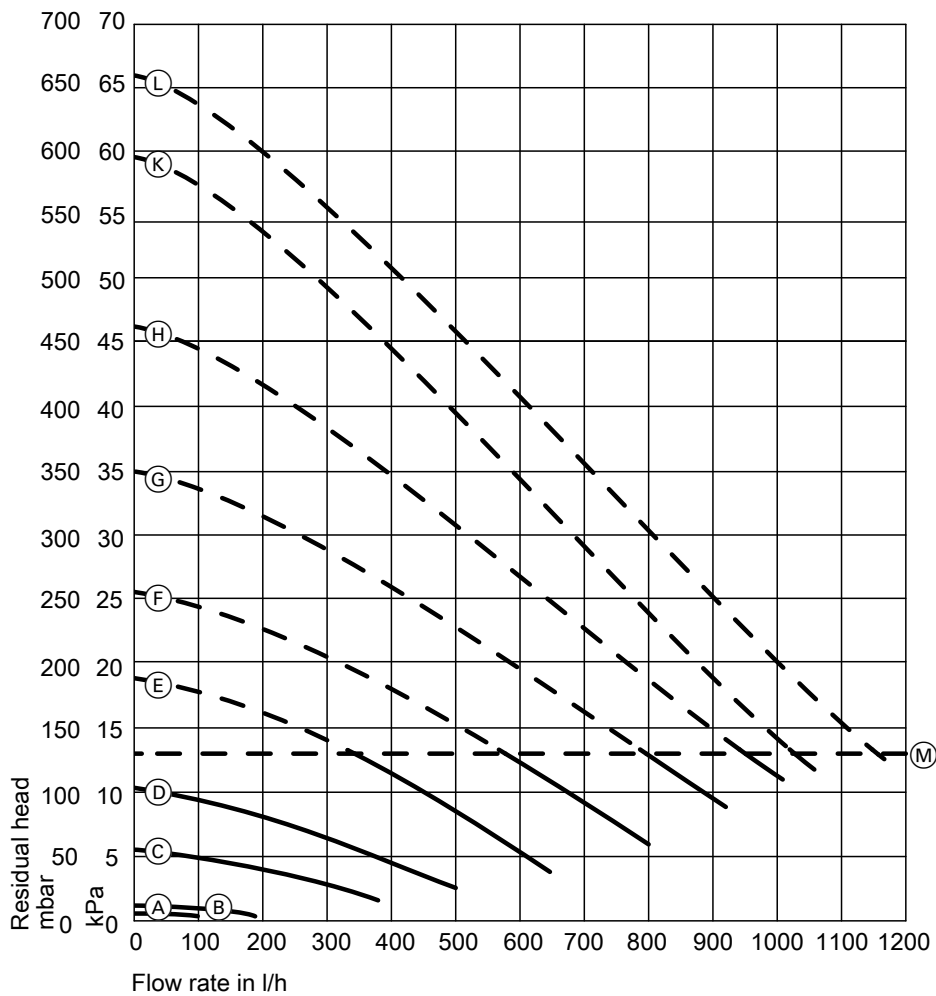

(M) Upper operational limit (integral bypass opens)

Curve	Pump rate, circulation pump
(A)	10 %
(B)	20 %
(C)	30 %
(D)	40 %
(E)	50 %
(F)	60 %
(G)	70 %
(H)	80 %
(K)	90 %
(L)	100 %

5.1 Product description

Control unit with 7-inch screen

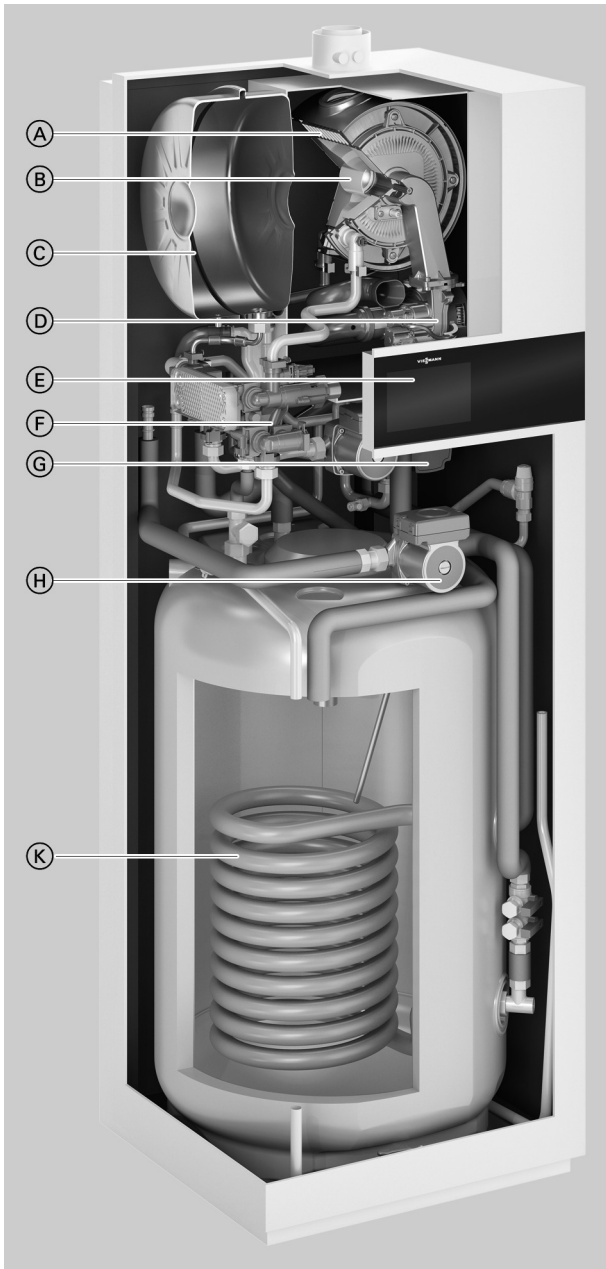

- Ⓐ Inox-Radial heat exchanger made from stainless steel – for high operational reliability, a long service life and high heating output on a very small footprint
- Ⓑ Modulating MatriX-Plus gas burner for extremely clean combustion
- Ⓒ Integral diaphragm expansion vessel
- Ⓓ Variable speed combustion air fan for quiet and economical operation
- Ⓔ Digital boiler control unit with colour touchscreen
- Ⓕ Hydraulics
- Ⓖ Integral, variable speed high efficiency circulation pump
- Ⓗ Integral, variable speed high efficiency solar circuit pump
- Ⓚ Dual mode DHW cylinder

Vitodens 242-F (cont.)

Control unit with 3.5-inch screen

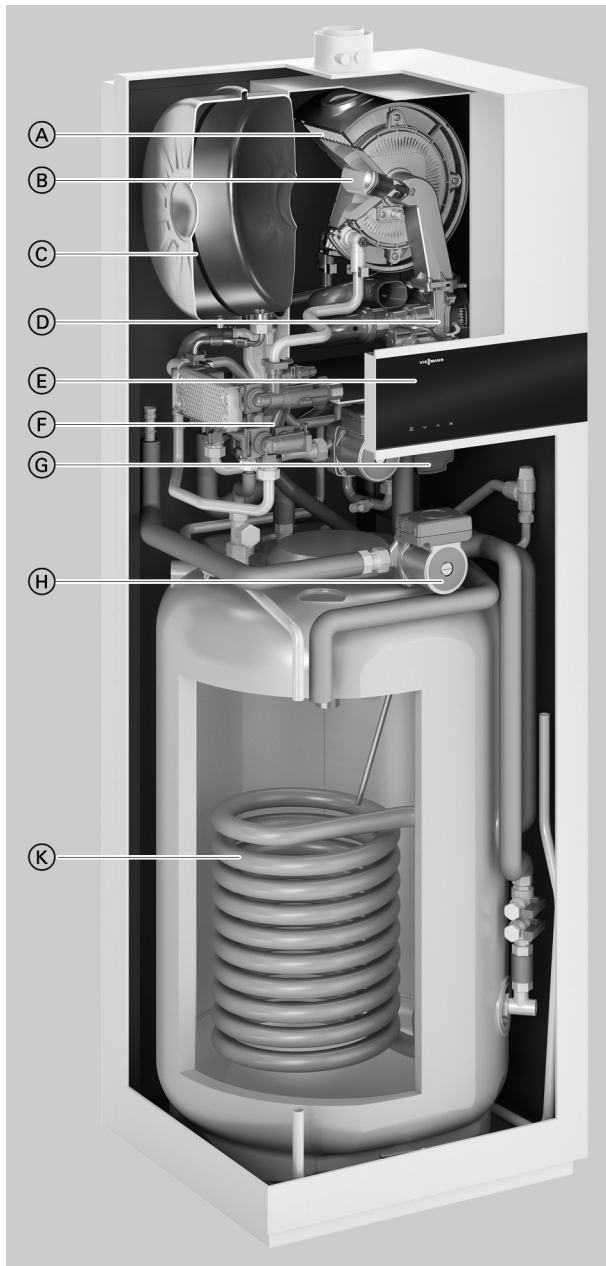

- Ⓐ Inox-Radial heat exchanger made from stainless steel – for high operational reliability, a long service life and high heating output on a very small footprint
- Ⓑ Modulating MatriX-Plus gas burner for extremely clean combustion
- Ⓒ Integral diaphragm expansion vessel
- Ⓓ Variable speed combustion air fan for quiet and economical operation
- Ⓔ Digital boiler control unit with black/white screen
- Ⓕ Hydraulics
- Ⓖ Integral, variable speed high efficiency circulation pump
- Ⓗ Integral, variable speed high efficiency solar circuit pump
- Ⓚ Dual mode DHW cylinder

5

The Vitodens 242-F gas condensing storage combi boiler is prepared at the factory for the direct connection of a solar thermal system. The solar control module is already integrated and is actuated via the control unit of the Vitodens 242-F

Fitted with the MatriX-Plus gas burner and stainless steel Inox-Radial heat exchanger, the Vitodens 242-F offers top technology for energy efficiency and a high level of heating and DHW convenience over the long term. The Lambda Pro Plus combustion controller and the variable speed high efficiency circulation pump ensure permanently high efficiency, reliable operation and low power consumption. The integral DHW cylinder with 170 l capacity for connecting a solar thermal system features high solar coverage of over 50 %. This is achieved by means of its large cylinder capacity and automatic reheating suppression.

Recommended applications

- Installation in detached and terraced houses
- New build (e.g. prefabricated houses and developer projects):
Installation in utility rooms

Benefits at a glance

Control unit with 7-inch screen

- Seasonal central heating energy efficiency η_s up to 93 % (label A).
- Low cycle frequency, even with low heat demand, due to optimised pauses and a wide modulation range down to 1:13
- Durable and efficient thanks to Inox-Radial stainless steel heat exchanger
- MatriX-Plus gas burner with Lambda Pro Plus combustion controller for permanently high efficiency and clean combustion
- Power saving, high efficiency circulation pumps for heating and solar circuit
- Colour touchscreen with plain text and graphic display, commissioning assistant, energy consumption indicators and the option of operation from a mobile device
- Web-enabled through integral WiFi interface for operation and service via Viessmann app

Vitodens 242-F (cont.)

- Safety valve on the solar side and drip pan for heat transfer medium integrated
- Solar coverage for DHW heating > 50 %

Benefits at a glance

Control unit with 3.5-inch screen

- Seasonal central heating energy efficiency η_s up to 93 % (label A).
- Low cycle frequency, even with low heat demand, due to optimised pauses and a wide modulation range down to 1:10
- Durable and efficient thanks to Inox-Radial stainless steel heat exchanger
- MatriX-Plus gas burner with Lambda Pro Plus combustion controller for permanently high efficiency and clean combustion
- Power saving, high efficiency circulation pumps for heating and solar circuit
- Black/white screen with plain text and graphic display, commissioning assistant, energy consumption indicators and the option of operation from a mobile device
- Web-enabled through integral WiFi interface for operation and service via Viessmann app
- Safety valve on the solar side and drip pan for heat transfer medium integrated
- Solar coverage for DHW heating > 50 %

Delivered condition

Gas condensing boiler with Inox-Radial heat exchanger, modulating MatriX-Plus gas burner for natural gas and LPG to DVGW Code of Practice G260 [Germany], expansion vessel, variable speed high efficiency circulation pumps for heating circuit and solar circuit, drip pan for heat transfer medium, safety valve on the solar side and integral DHW solar cylinder.

Weather-compensated or constant temperature control unit with integral WiFi interface and solar control module.

Fully plumbed and wired.

White epoxy-coated casing.

Preset for operation with natural gas. Conversion within gas groups E/LL is not required. The conversion to LPG is made at the control unit (a conversion kit is not required).

Accessories required (order separately)

Surface mounting

- Connection set for surface mounting; upward connection or
- Connection set for surface mounting; connection to the left or right or

Flush mounting

- Connection set for flush mounting

Tested quality

 CE designation according to current EU Directives

Meets the requirements for the "Blue Angel" ecolabel to RAL UZ 61.

5.2 Specification

Gas boiler, type B and C, category II _{2N3P}		B2UE		
Type		B2UE		
Rated heating output range (details to EN 15502)				
T _F /T _R = 50/30 °C				
Natural gas	kW	1.9 - 11.0	1.9 - 19.0	1.9 - 25.0
LPG	kW	2.5 - 11.0	2.5 - 19.0	2.5 - 25.0
T _F /T _R = 80/60 °C				
Natural gas	kW	1.7 - 10.1	1.7 - 17.4	1.7 - 22.9
LPG	kW	2.2 - 10.1	2.2 - 17.4	2.2 - 22.9
Rated heating output for DHW heating				
Natural gas	kW	1.7 - 17.4	1.7 - 21.8	1.7 - 28.3
LPG	kW	2.2 - 17.4	2.2 - 21.8	2.2 - 28.3
Rated heat input				
Natural gas	kW	1.8 - 18.1	1.8 - 22.7	1.8 - 29.5
LPG	kW	2.3 - 18.1	2.3 - 22.7	2.3 - 29.5
Product ID		CE-0085CT0017		
IP rating to EN 60529		IP X4		
– In conjunction with assembly kit (accessories)		IP X1		
Gas supply pressure				
Natural gas	mbar	20	20	20
	kPa	2	2	2
LPG	mbar	50	50	50
	kPa	5	5	5
Max. perm. gas supply pressure^{*11}				
Natural gas	mbar	25.0	25.0	25.0
	kPa	2.5	2.5	2.5
LPG	mbar	57.5	57.5	57.5
	kPa	5.75	5.75	5.75
Sound power level (to EN ISO 15036-1)				
– At partial load	dB(A)	32	32	32
– At rated heating output (DHW heating)	dB(A)	41	47	49
Power consumption (delivered condition)	W	37	54	68
Weight				
– Excl. heating water and DHW	kg	154	154	154
– Incl. heating water and DHW	kg			
Water capacity (excl. diaphragm expansion vessel)	l	3.0	3.0	3.0
Solar circuit capacity	l	9.9	9.9	9.9
Max. flow temperature	°C	82	82	82
Max. flow rate (Limit for the use of hydraulic separation)	l/h	See residual head graph		
Nominal circulating water volume At T _F /T _R = 80/60 °C	l/h	473	818	1076
Expansion vessel				
Capacity	l	18	18	18
Pre-charge pressure	bar	0.75	0.75	0.75
	kPa	75	75	75
Permiss. operating pressure				
– Heating circuit	bar	3	3	3
	MPa	0.3	0.3	0.3
– Solar circuit	bar	6	6	6
	MPa	0.6	0.6	0.6
Connections (with connection accessories)				
Boiler flow and return	R	¾	¾	¾
Solar flow and return	R/Ø mm	¾/22	¾/22	¾/22
Cold water and DHW	R	½	½	½
DHW circulation	R	½	½	½
Dimensions				
Length	mm	595	595	595
Width	mm	600	600	600
Height	mm	1800	1800	1800
Gas connection (with connection accessories)	R	½	½	½

^{*11} If the gas supply pressure is higher than the maximum permissible value, install a separate gas pressure governor upstream of the system.

Vitodens 242-F (cont.)

Gas boiler, type B and C, category II _{2N3P}		B2UE		
Type				
Rated heating output range (details to EN 15502)				
$T_F/T_R = 50/30\text{ °C}$				
Natural gas	kW	1.9 - 11.0	1.9 - 19.0	1.9 - 25.0
LPG	kW	2.5 - 11.0	2.5 - 19.0	2.5 - 25.0
$T_F/T_R = 80/60\text{ °C}$				
Natural gas	kW	1.7 - 10.1	1.7 - 17.4	1.7 - 22.9
LPG	kW	2.2 - 10.1	2.2 - 17.4	2.2 - 22.9
DHW cylinder				
Capacity	l	170	170	170
Permiss. operating pressure (DHW side)	bar	10	10	10
	MPa	1	1	1
Continuous DHW output	kW	17.48	21.70	26.51
For DHW heating from 10 to 45 °C	l/h	425.40	529.20	655.20
Performance factor N_L *12		1.2	1.5	On request
Initial DHW output	l/10 min	153.00	168.40	On request
For DHW heating from 10 to 45 °C				
Supply values				
Relative to the max. load and 1013 mbar/15 °C				
With gas				
Natural gas E	m ³ /h	1.92	2.40	3.12
Natural gas LL	m ³ /h	2.23	2.79	3.63
LPG	kg/h	1.41	1.76	2.29
Flue gas parameters *13				
Temperature (at a return temperature of 30 °C)				
– At rated heating output	°C	39	41	46
– At partial load	°C	38	38	38
Temperature (at a return temperature of 60 °C)				
	°C	65	67	72
Mass flow rate				
Natural gas				
– At rated heating output	kg/h	32.2	40.4	54.2
– At partial load	kg/h	3.2	3.2	3.2
LPG				
– At rated heating output	kg/h	30.6	39.8	53.2
– At partial load	kg/h	3.9	3.9	3.9
Available draught				
	Pa	250	250	250
	mbar	2.5	2.5	2.5
Max. amount of condensate	l/h	2.5	3.2	4.1
To DWA-A 251				
Condensate connection (hose nozzle)	Ø mm	20 - 24	20 - 24	20 - 24
Flue gas connection	Ø mm	60	60	60
Ventilation air connection	Ø mm	100	100	100
Standard seasonal efficiency [to DIN] at				
$T_F/T_R = 40/30\text{ °C}$	%	Up to 98 (H _s) [gross cv]		
Energy efficiency class				
– Heating		A	A	A
– DHW heating, draw-off profile XL		B	B	B

*12 At 70 °C average boiler water temperature and cylinder storage temperature $T_{cyl} = 60\text{ °C}$.

DHW performance factor N_L depends on cylinder storage temperature T_{cyl} .

Standard values: $T_{cyl} = 60\text{ °C} \rightarrow 1.0 \times N_L$ $T_{cyl} = 55\text{ °C} \rightarrow 0.75 \times N_L$ $T_{cyl} = 50\text{ °C} \rightarrow 0.55 \times N_L$ $T_{cyl} = 45\text{ °C} \rightarrow 0.3 \times N_L$.

*13 Calculation values for sizing the flue system to EN 13384.

Flue gas temperatures measured as gross values at 20 °C combustion air temperature.

The flue gas temperature at a return temperature of 30 °C is significant for sizing the flue system.

The flue gas temperature at a return temperature of 60 °C is used to determine the application range of flue pipes with maximum permissible operating temperatures.

Vitodens 242-F (cont.)

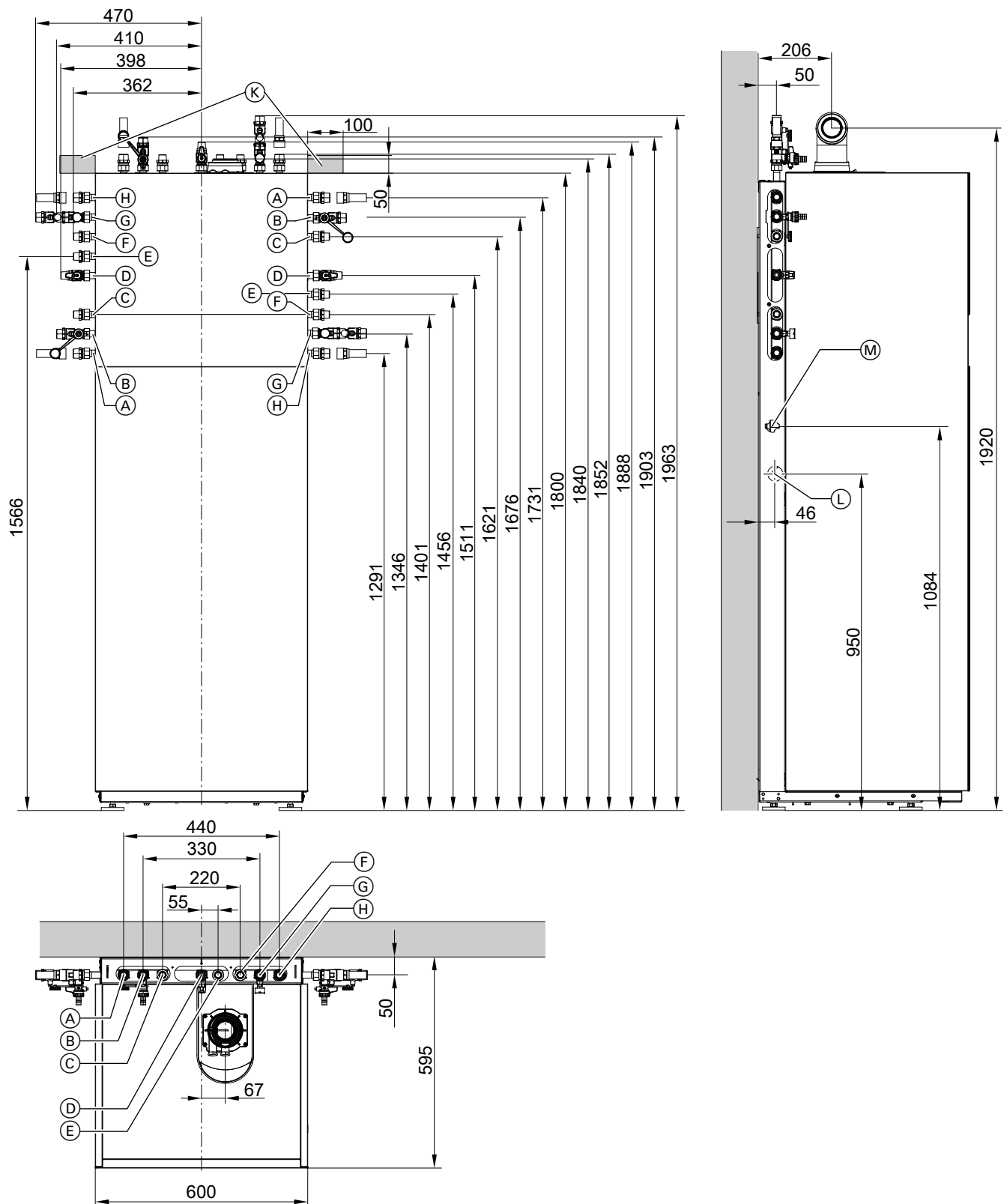

- (A) Solar return R $\frac{3}{4}$
- (B) Heating flow R $\frac{3}{4}$
- (C) DHW R $\frac{1}{2}$
- (D) Gas connection R $\frac{1}{2}$
- (E) DHW circulation R $\frac{1}{2}$ (separate accessories)
- (F) Cold water R $\frac{1}{2}$
- (G) Heating return R $\frac{3}{4}$
- (H) Solar flow R $\frac{3}{4}$

- (K) Area for electrical cables (on-site junction box)
- (L) Condensate drain to the side
- (M) External plug for electrical connections

Vitodens 242-F (cont.)

Note

The dimensioned drawing shows an example of valves/fittings for surface mounting, upward connection and connection to the left/right.

Order the connection sets separately as accessories.

Note

The appliance is delivered fitted with a flexible power cable (1.5 m long). Lay the required power cables on site and route them into the boiler through the back.

Variable speed heating circuit pump in the Vitodens 242-F

The integral circulation pump is a highly efficient pump with substantially lower power consumption than conventional pumps.

The pump speed and consequently the pump rate are regulated subject to the outside temperature and the switching times for heating mode or reduced mode. The control unit transmits the current speed specifications to the circulation pump via a PWM signal.

The min. and max. speeds and the speed for reduced mode can be matched to the existing heating system via parameters at the control unit.

Setting (%) in the heating circuit 1 group:

- Min. speed: Parameter 1102.0
- Max. speed: Parameter 1102.1

- In the delivered condition, the minimum pump rate and the maximum pump rate are set to the following values:

Rated heating output in kW	Speed settings in the delivered condition in %	
	Min. pump rate	Max. pump rate
11	65	65
19	65	80
25	65	100

- In conjunction with a low loss header, heating water buffer cylinder and heating circuits with mixer, the internal circulation pump runs at a constant speed.

Note

All height dimensions have a tolerance of +15 mm on account of the adjustable feet.

Siting information

Site the Vitodens 242-F with its back flush against the wall.

Specification – circulation pump

Rated heating output	kW	11	19	25
Circulation pump	Type	UPM3 15-60	UPM3 15-60	UPM3 15-60
Rated voltage	V~	230	230	230
Power consumption				
– Max.	W	42	42	42
– Min.	W	2	2	2
– Delivered condition	W	14.6	28.1	42.0
Energy efficiency class		A	A	A
Energy efficiency index (EEI)		≤ 0.20	≤ 0.20	≤ 0.20

Vitodens 242-F (cont.)

Residual head of integral circulation pump

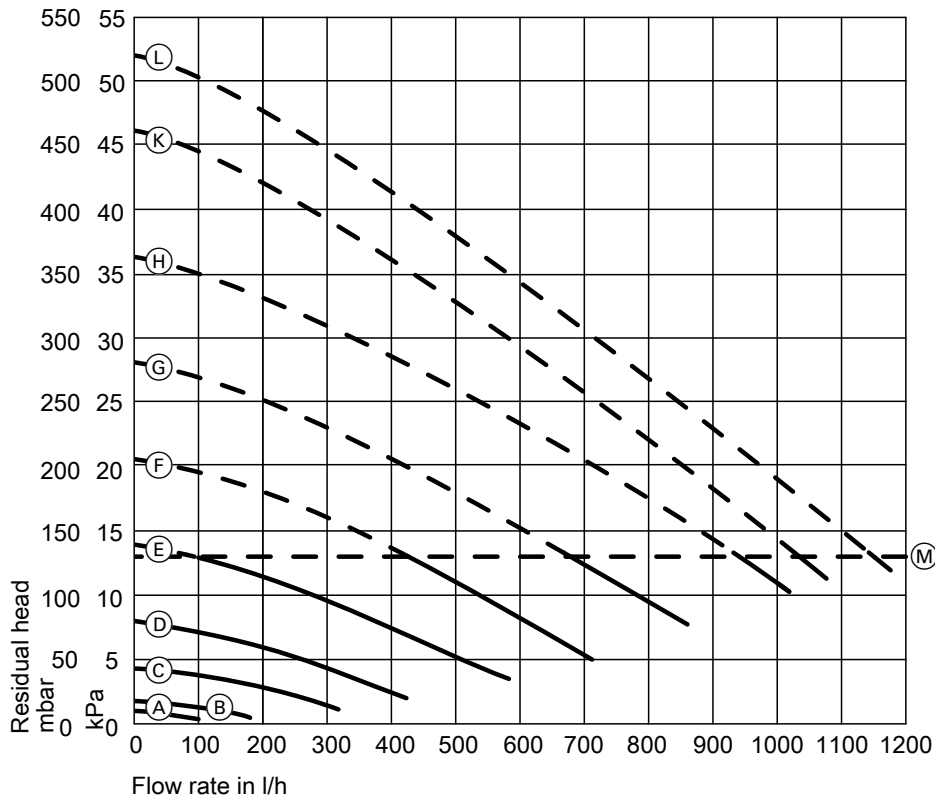

(M) Upper operational limit (integral bypass opens)

5

Curve	Pump rate, circulation pump
(A)	10 %
(B)	20 %
(C)	30 %
(D)	40 %
(E)	50 %
(F)	60 %
(G)	70 %
(H)	80 %
(K)	90 %
(L)	100 %

Variable speed solar circuit pump in the Vitodens 242-F

The integral solar circuit pump is a highly efficient circulation pump with substantially lower power consumption than conventional pumps.

The min. and max. speed and therefore the pump rate are set via parameters on the control unit. The control unit transmits the current speed specifications to the circulation pump via PWM signal.

Type		VI Solar PM2 15-85
Rated voltage	V~	230
Power consumption		
– Max.	W	55
– Min.	W	3
Energy efficiency class		A

Vitodens 242-F (cont.)

Residual head of the integral solar circuit pump



Separate DHW cylinders for Vitodens 200-W

6.1 Vitocell 100-W below the boiler (type CUGA and CUGA-A), made from steel, with Ceraprotect enamel coating

- Installed below the boiler
- With internal indirect coil, made from steel, with Ceraprotect enamel coating

Specification

Type		CUG	CUGA	CUGA-A	CUGA	CUGA-A
Cylinder capacity	l	100	120	120	150	150
Heating water capacity	l	6	6.5	6.5	6.5	6.5
Gross volume	l	106	126.5	126.5	156.5	156.5
DIN registration no.		9W245/11-13 MC/E				
Connections (male thread)						
Heating water flow and return	R	1	1	1	1	1
DHW and cold water	R	3/4	3/4	3/4	3/4	3/4
DHW circulation	R	3/4	3/4	3/4	3/4	3/4
Permiss. operating pressure						
Heating water and DHW sides	bar	10	10	10	10	10
	MPa	1	1	1	1	1
Permissible temperatures						
- Heating water side	°C	160	160	160	160	160
- DHW side	°C	95	95	95	95	95
Standby heat loss	kWh/24 h	1.49	1.10	0.75	1.21	0.84
Dimensions						
Length a	mm	574	596	596	641	641
Width b	Ømm	553	596	596	641	641
Height c	mm	836	914	914	942	942
Weight	kg	51	75	75	88	88
Heating surface	m ²	0.9	1.0	1.0	1.0	1.0
Energy efficiency class		C	B	A	B	A

Vitocell 100-W, type CUG, 100 l

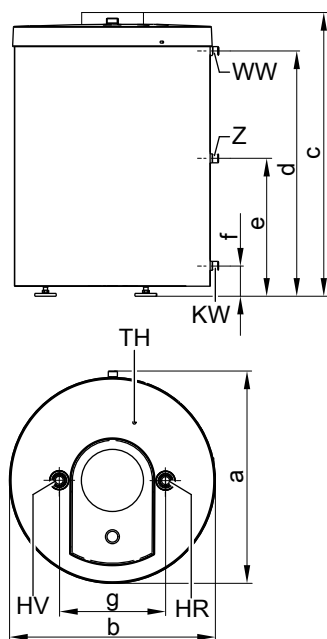

Dimensions

Dimension		
a	mm	574
b	mm	553
c	mm	836
d	mm	700
e	mm	399
f	mm	78
g	mm	308

- HR Heating return
- HV Heating flow
- KW Cold water (drain)
- WW DHW
- TH Sensor well for cylinder temperature sensor (internal diameter 7 mm)
- Z DHW circulation

Separate DHW cylinders for Vitodens 200-W (cont.)

Vitocell 100-W, type CUGA/CUGA-A, 120 and 150 l

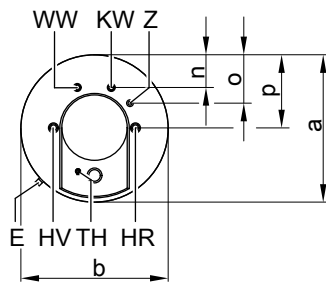
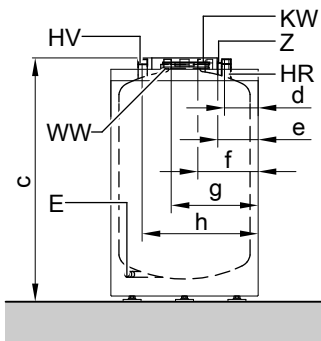

- E Drain
- HR Heating return
- HV Heating flow
- KW Cold water
- WW DHW
- TH Sensor well for cylinder temperature sensor (internal diameter 7 mm)
- Z DHW circulation

Dimensions

Type		CUGA	CUGA-A	CUGA	CUGA-A
Capacity		120 l		150 l	
a	mm	596	596	641	641
b	mm	596	596	641	641
c	mm	914	914	942	942
d	mm	144	144	166	166
e	mm	165	165	187	187
f	mm	236	236	252	252
g	mm	361	361	382	382
h	mm	452	452	474	474
n	mm	148	148	170	170
o	mm	205	205	227	227
p	mm	298	298	320	320

Separate DHW cylinders for Vitodens 200-W (cont.)

Pressure drop on the DHW side

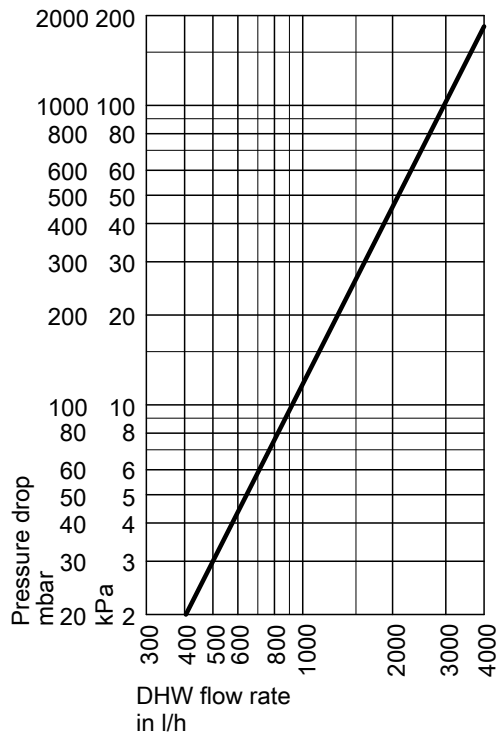

DHW output data at rated heating output

Rated heating output for DHW heating	kW	17.3	22.7	29.1
Continuous DHW output	kW	17.3	22.7	24
for DHW heating from 10 to 45 °C and an average boiler water temperature of 78 °C	l/h	425	555	590
Performance factor N_L				
to DIN 4708				
Cylinder capacity 120 l		1.2	1.2	1.2
Cylinder capacity 150 l		1.6	1.6	1.6
Peak output				
over 10 minutes				
Cylinder capacity 120 l	l/10 min	153	153	153
Cylinder capacity 150 l	l/10 min	173	173	173

Delivered condition

Vitocell 100-W, type CUG, CUGA, CUGA-A

The colour of the epoxy-coated sheet steel casing is white.

100, 120 and 150 l capacity

DHW cylinder made from steel with Ceraprotect enamel coating.

- Welded sensor well for cylinder temperature sensor
- Threaded adjustable feet
- Protective magnesium anode
- Fitted thermal insulation

Separate DHW cylinders for Vitodens 200-W (cont.)

6.2 Vitocell 100-W, type CVA, CVAA and CVAA-A adjacent to the boiler – 160, 200 and 300 l, white finish, made from steel, with Ceraprotect enamel coating

- Adjacent to the boiler
- With internal indirect coil, made from steel, with Ceraprotect enamel coating

For further technical details, see the separate datasheet for the Vitocell 100-V.

Specification

Type		CVAA-A	CVA	CVAA-A	CVA	CVAA
Cylinder capacity (AT: Actual water capacity)	l	160		200		300
Heating water capacity	l	5.5		5.5		10.0
Gross volume	l	165.5		205.5		310.0
DIN registration no.		9W241/11-13 MC/E				
Connections (male thread)						
Heating water flow and return	R	1		1		1
DHW and cold water	R	¾		¾		1
DHW circulation	R	¾		¾		1
Permissible operating pressure						
– Heating water side	bar	25		25		25
	MPa	2.5		2.5		2.5
– DHW side	bar	10		10		10
	MPa	1		1		1
Permissible temperatures						
– Heating water side	°C	160		160		160
– DHW side	°C	95		95		95
Standby heat loss	kWh/24 h	0.97	1.35	1.04	1.46	1.65
Dimensions						
Length a (∅)	mm	581		581		667
Width b	mm	605		605		744
Height c	mm	1189		1409		1734
Weight	kg	86		97		156
Energy efficiency class						
		A	B	A	B	B

Separate DHW cylinders for Vitodens 200-W (cont.)

Vitocell 100-V, type CVA/CVAA-A, 160 and 200 l capacity

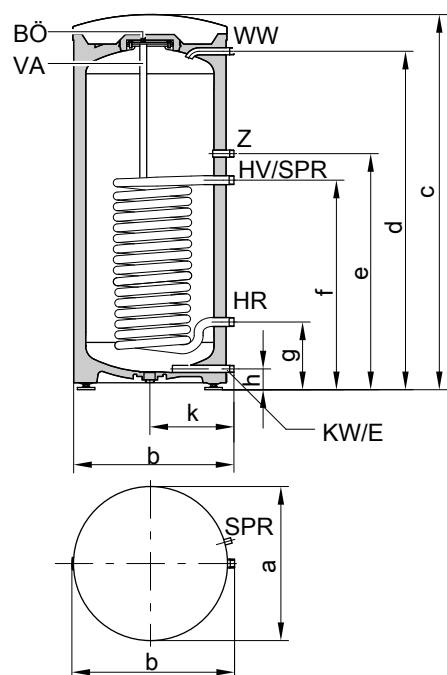

Dimensions

Cylinder capacity		160	200
Length (∅)	a mm	581	581
Width	b mm	605	605
Height	c mm	1189	1409
	d mm	1050	1270
	e mm	884	884
	f mm	634	634
	g mm	249	249
	h mm	72	72
	k mm	317	317

- BÖ Inspection and cleaning aperture
- E Drain outlet
- HR Heating water return
- HV Heating water flow
- KW Cold water
- SPR Cylinder temperature sensor of the cylinder temperature controller or thermostat
- VA Protective magnesium anode
- WW DHW
- Z DHW circulation

Separate DHW cylinders for Vitodens 200-W (cont.)

Vitocell 100-V, type CVAA, 300 l capacity

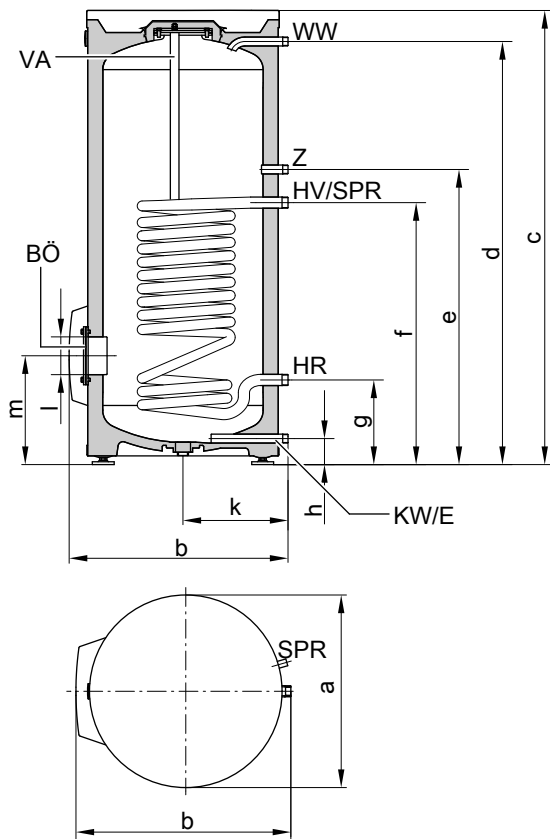

Dimensions

Cylinder capacity		l	300
Length (∅)	a	mm	667
Width	b	mm	744
Height	c	mm	1734
	d	mm	1600
	e	mm	1115
	f	mm	875
	g	mm	260
	h	mm	76
	k	mm	361
	l	mm	∅ 100
	m	mm	333

- BÖ Inspection and cleaning aperture
- E Drain outlet
- HR Heating water return
- HV Heating water flow
- KW Cold water
- SPR Cylinder temperature sensor of the cylinder temperature controller or thermostat
- VA Protective magnesium anode
- WW DHW
- Z DHW circulation

Separate DHW cylinders for Vitodens 200-W (cont.)

Pressure drop on the DHW side

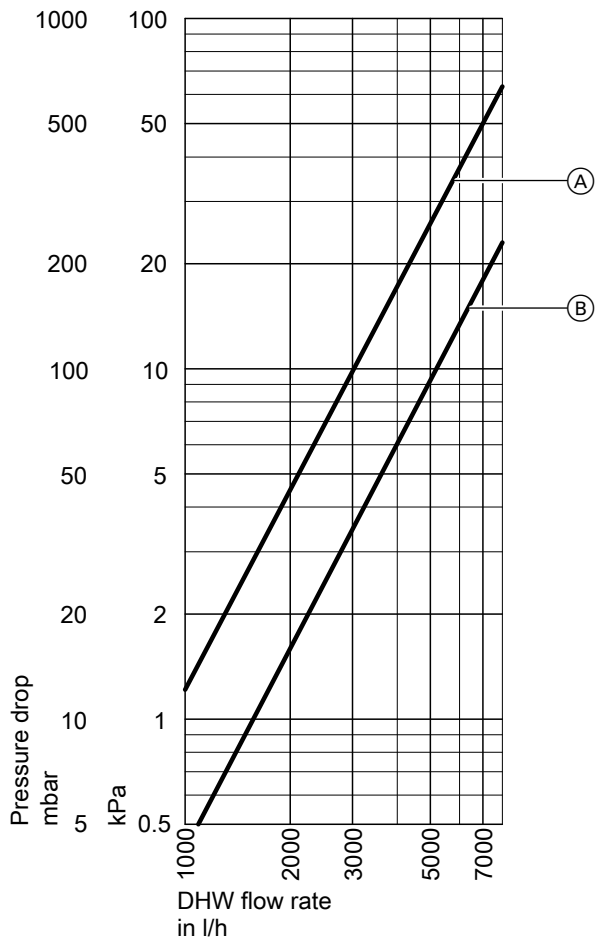

- (A) 160 and 200 l
(B) 300 l

DHW output data at rated heating output

Rated heating output for DHW heating		kW	17.3	22.7	29.1
Continuous DHW output for DHW heating from 10 to 45 °C and an average boiler water temperature of 78 °C					
Cylinder capacity 160 and 200 l	kW	17.3	22.7	29.1	26
	l/h	425	555	638	638
Cylinder capacity 300 l	kW	17.3	22.7	29.1	29.1
	l/h	425	555	555	715
Performance factor N_L to DIN 4708					
Cylinder capacity 160 l		2.1	2.2	2.2	2.2
Cylinder capacity 200 l		3.1	3.2	3.2	3.2
Cylinder capacity 300 l		7.5	8.0	8.0	8.0
Peak output over 10 minutes					
Cylinder capacity 160 l	l/10 min	192	199	199	199
Cylinder capacity 200 l	l/10 min	233	236	236	236
Cylinder capacity 300 l	l/10 min	360	368	368	368

Delivered condition

- DHW cylinder made from steel with Ceraprotect enamel coating.
- Integral welded sensor well for cylinder temperature sensor or temperature controller
- Threaded adjustable feet

- Protective magnesium anode
- Fitted thermal insulation

Separate DHW cylinders for Vitodens 200-W (cont.)

6.3 Vitocell 200-W, type EVIA-A and EVIA-A+adjacent to the boiler, 160 and 200 l, white finish, with internal indirect coil, made from stainless steel

- Adjacent
 - Heated by an internal indirect coil; made from stainless steel
- For further technical details, see the separate datasheet for the Vitocell 300-V.

Type		EVIA-A+	EVIA-A+	EVIA-A	EVIA-A
Cylinder capacity (AT: Actual water capacity)	l	160	200	160	200
Heating water capacity	l	7.4	7.4	7.4	7.4
Gross volume	l	167.4	207.4	167.4	207.4
DIN registration no.		Applied for		9W71-10MC/E	
Connections (male thread)					
Heating water flow and return	R	1	1	1	1
Cold water, DHW	R	¾	¾	¾	¾
DHW circulation	R	¾	¾	¾	¾
Permiss. operating pressure					
– Heating water side	bar	10	10	10	10
	MPa	1	1	1	1
– DHW side	bar	10	10	10	10
	MPa	1	1	1	1
Permiss. temperatures					
– Heating water side	°C	160	160	160	160
– DHW side	°C	95	95	95	95
Standby heat loss	kWh/24 h	0.70	0.75	0.90	0.91
Dimensions					
Length a (∅)	mm	581	581	581	581
Width b	mm	605	605	605	605
Height d	mm	1189	1409	1189	1409
Weight	kg	62	72	60	70
Energy efficiency class		A	A	A	A

Separate DHW cylinders for Vitodens 200-W (cont.)

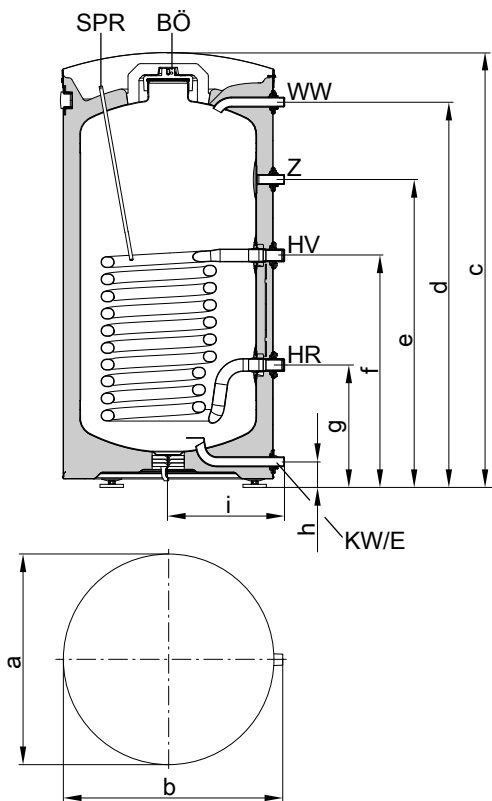

Cylinder capacity	l	160	200
a	mm	581	581
b	mm	605	605
c	mm	1189	1409
d	mm	1055	1275
e	mm	843	885
f	mm	635	635
g	mm	335	335
h	mm	70	70
i	mm	317	317

- BÖ Inspection and cleaning aperture
- E Drain
- HR Heating water return
- HV Heating water flow
- KW Cold water
- SPR Sensor well for cylinder temperature sensor (internal diameter 7 mm)
- WW DHW
- Z DHW circulation

Pressure drop on the DHW side

See the separate datasheet for the Vitocell 300-V.

DHW output data at rated heating output

Rated heating output for DHW heating	kW	17.3	22.7	29.1
Continuous DHW output				
for DHW heating from 10 to 45 °C and an average boiler water temperature of 70 °C				
Cylinder capacity 160 l	kW	17.3	22.7	26
	l/h	425	555	630
Cylinder capacity 200 l	kW	17.3	22.7	28
	l/h	425	555	680
Performance factor N_L				
to DIN 4708				
Cylinder capacity 160 l		1.7	1.7	1.7
Cylinder capacity 200 l		2.9	2.9	2.9
Peak output				
over 10 minutes				
Cylinder capacity 160 l	l/10 min	177	177	177
Cylinder capacity 200 l	l/10 min	226	226	226

Delivered condition

Vitocell 300-W, type EVIA-A+/EVIA-A
160 to 200 l capacity
 DHW cylinder made from stainless steel.

- Integral welded sensor well for cylinder temperature sensor/ temperature controller (internal diameter 17 mm)
- Thermometer



Separate DHW cylinders for Vitodens 200-W (cont.)

- Adjustable feet
- Fitted thermal insulation

Separate DHW cylinders for Vitodens 200-W (cont.)

6.4 Vitocell 100-W, type CVB and CVBB adjacent to the boiler – 300 and 400 l, white finish, made from steel with Ceraprotect enamel coating for dual mode DHW heating

- Adjacent to the boiler
 - With internal indirect coil, made from steel, with Ceraprotect enamel coating
 - For dual mode DHW heating
- For further technical details, see the separate datasheet for the Vitocell 100-B.

Type		CVBB	CVB
Cylinder capacity (AT: Actual water capacity)	l	300	400
Heating water capacity	l	16	17
Gross volume	l	316	417
DIN registration no.		9W242/11-13 MC/E	
Connections (male thread)			
Heating water flow and return	R	1	1
DHW and cold water	R	1	1¼
DHW circulation	R	1	1
Permiss. operating pressure			
Heating water, solar and DHW sides	bar MPa	10 1	10 1
Permiss. temperatures			
– Heating water side	°C	160	160
– Solar side	°C	160	160
– DHW side	°C	95	95
Standby heat loss	kWh/24 h	1.65	1.80
Dimensions			
Length a (∅)	mm	667	859
Width b	mm	744	923
Height d	mm	1734	1624
Weight	kg	166	167
Energy efficiency class		B	B

Separate DHW cylinders for Vitodens 200-W (cont.)

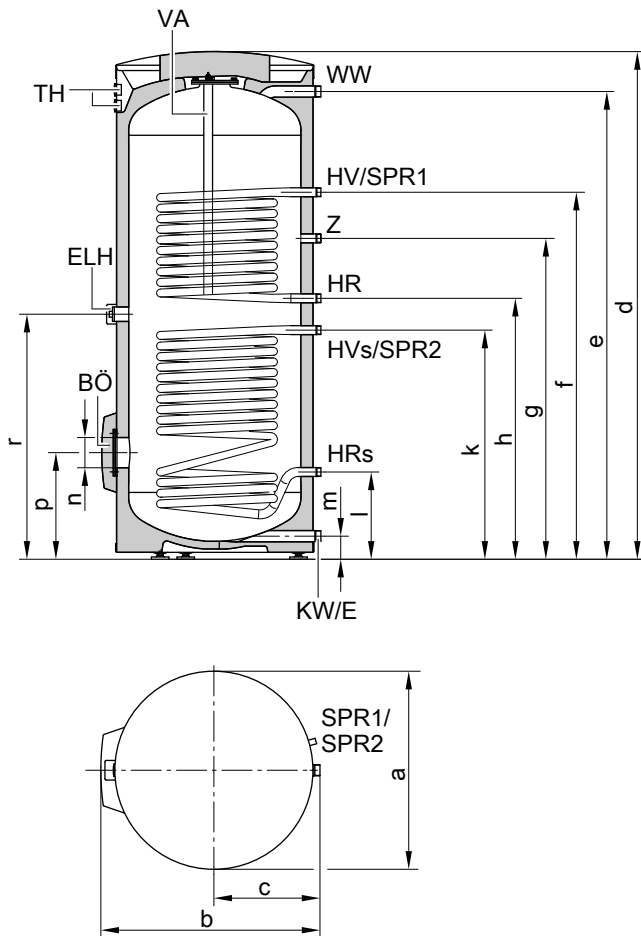

E	Drain outlet
ELH	Connector for immersion heater
HR	Heating water return, boiler
HR _S	Heating water return, solar
HV	Heating water flow, boiler
HV _S	Heating water flow, solar
KW	Cold water

BÖ	Inspection and cleaning aperture
SPR1	Sensor well for cylinder temperature sensor or temperature controller
SPR2	Temperature sensors/thermometer
TH	Thermometer
VA	Protective magnesium anode
WW	DHW
Z	DHW circulation

Dimensions

Cylinder capacity	l	300	400
a	mm	∅ 667	∅ 859
b	mm	744	923
c	mm	361	455
d	mm	1734	1624
e	mm	1600	1458
f	mm	1355	1204
g	mm	1115	1044
h	mm	995	924
k	mm	875	804
l	mm	260	349
m	mm	76	107
n	mm	∅ 100	∅ 100
p	mm	333	422
r	mm	935	864

Separate DHW cylinders for Vitodens 200-W (cont.)

Recommended positioning of the cylinder temperature sensor for solar operation

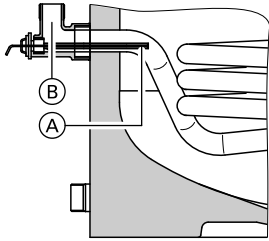

- (A) Cylinder temperature sensor (solar control unit)
- (B) Threaded elbow with sensor well (standard delivery)

Pressure drop on the DHW side

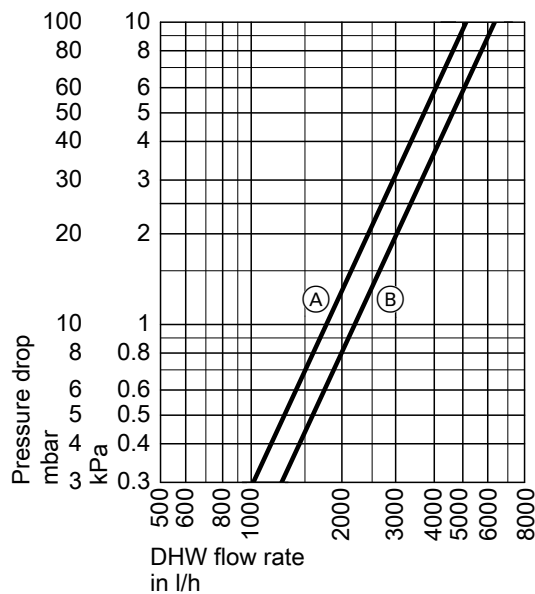

- (A) 300 l capacity
- (B) 400 l capacity

DHW output data at rated heating output

Rated heating output for DHW heating	kW	17.3	22.7	29.1
Continuous DHW output for DHW heating from 10 to 45 °C and an average boiler water temperature of 78 °C	kW	17.3	22.7	26
	l/h	425	555	638
Performance factor N_L^{*14} to DIN 4708		1.4	1.4	1.4
Peak output over 10 minutes	l/10 min	164	164	164

*14 Values for the upper indirect coil.

Separate DHW cylinders for Vitodens 200-W (cont.)

Delivered condition

Vitocell 100-W, type CVBB 300 l

- DHW cylinder made from steel with Ceraprotect enamel coating
- 2 integral welded sensor wells for cylinder temperature sensor or temperature controller (internal diameter 16 mm)
 - Threaded elbow with sensor well (internal diameter 6.5 mm)
 - Adjustable feet
 - Protective magnesium anode
 - Fitted thermal insulation

Vitocell 100-W, type CVB 400 l

- DHW cylinder made from steel with Ceraprotect enamel coating
- 2 integral welded sensor wells for cylinder temperature sensor or temperature controller (internal diameter 16 mm)
 - Threaded elbow with sensor well (internal diameter 6.5 mm)
 - Adjustable feet
 - Protective magnesium anode

Packed separately:

- Removable thermal insulation

Installation accessories

7.1 Vitodens 200-W installation accessories

Pre-plumbing jigs

Pre-plumbing jig for surface mounting

For gas condensing system boiler

Part no. ZK04307

Comprising:

- Fixings
- Valves/fittings, heating flow/heating return
- Boiler drain & fill valve
- Air vent valve
- Pressure gauge
- Gas shut-off valve with thermally activated safety shut-off valve

Connections (male thread)

Gas shut-off valve	R	3/4
Heating flow/heating return	R	3/4

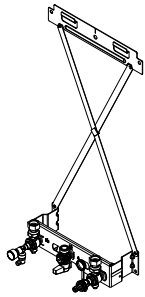

Pre-plumbing jig for surface mounting

For gas condensing system boiler

Part no. ZK04918

Comprising:

- Fixings
- Valves/fittings, heating flow/heating return with pipe bend
- Boiler drain & fill valve
- Air vent valve
- Pressure gauge
- Gas shut-off valve

Connections

Gas shut-off valve (male thread)	R	3/4
Heating flow/heating return (external diameter)	Ø mm	20

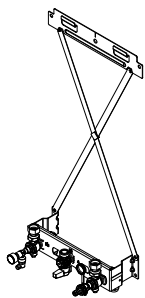

Pre-plumbing jig for surface mounting

For gas condensing combi boiler

Part no. ZK04919

Comprising:

- Fixings
- Valves/fittings, heating flow/heating return
- Valves/fittings, cold water/DHW
- Boiler drain & fill valve
- Air vent valve
- Pressure gauge
- Gas shut-off valve with thermally activated safety shut-off valve

Connections (male thread)

Gas shut-off valve	R	3/4
Heating flow/heating return	R	3/4
Cold water/DHW	R	1/2

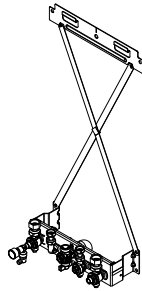

Pre-plumbing jig for surface mounting

For gas condensing combi boiler

Part no. ZK04920

Comprising:

- Fixings
- Valves/fittings, heating flow/heating return with pipe bend
- Valves/fittings, cold water/DHW with pipe bend
- Boiler drain & fill valve
- Air vent valve
- Pressure gauge
- Gas shut-off valve

Connections

Gas shut-off valve (male thread)	R	3/4
Heating flow/heating return (internal diameter)	Ø mm	20
Cold water/DHW (internal diameter)	Ø mm	16

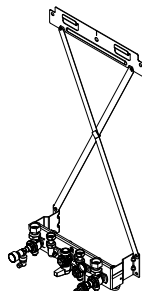

Installation accessories (cont.)

Refilling device for pre-plumbing jig

For gas condensing system boiler

Part no. ZK02163

- With pipe separator
- Connection R ¼

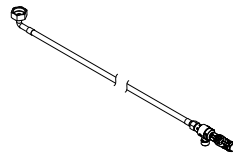

Valves/fittings

Valves/fittings for surface mounting

For gas condensing system boiler

Part no. ZK04669

Comprising:

- Valves/fittings, heating flow/heating return
- Boiler drain & fill valve
- Air vent valve
- Pressure gauge
- Gas shut-off valve with thermally activated safety shut-off valve

Connections (male thread)		
Gas shut-off valve	R	¾
Heating flow/heating return	R	¾

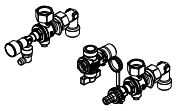

Valves/fittings for surface mounting

For gas condensing system boiler

Part no. ZK04924

Comprising:

- Valves/fittings, heating flow/heating return with pipe bend
- Boiler drain & fill valve
- Air vent valve
- Pressure gauge
- Gas shut-off valve

Connections (male thread)		
Gas shut-off valve	R	¾
Heating flow/heating return (internal diameter)	Ø mm	20

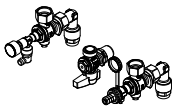

Valves/fittings for surface mounting

For gas condensing combi boiler

Part no. ZK04925

Comprising:

- Valves/fittings, heating flow/heating return
- Valves/fittings, cold water/DHW
- Boiler drain & fill valve
- Air vent valve
- Pressure gauge
- Gas shut-off valve with thermally activated safety shut-off valve

Connections (male thread)		
Gas shut-off valve	R	¾
Heating flow/heating return	R	¾
Cold water/DHW	R	½

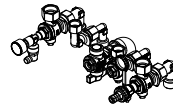

Valves/fittings for surface mounting

For gas condensing combi boiler

Part no. ZK04927

Comprising:

- Valves/fittings, heating flow/heating return
- Valves/fittings, cold water/DHW
- Boiler drain & fill valve
- Air vent valve
- Pressure gauge
- Gas shut-off valve

Connections		
Gas shut-off valve (male thread)	R	¾
Heating flow/heating return (internal diameter)	Ø mm	20
Cold water/DHW (internal diameter)	Ø mm	16



Valves/fittings for flush mounting

Part no. ZK04670

For gas condensing system boiler

Comprising:

- Valves/fittings, heating flow/heating return
- Boiler drain & fill valve
- Air vent valve
- Pressure gauge
- Gas shut-off valve with thermally activated safety shut-off valve
- Mounting plate, flush mounting

Connections (male thread)		
Gas shut-off valve	R	¾
Heating flow/heating return	R	¾

Installation accessories (cont.)

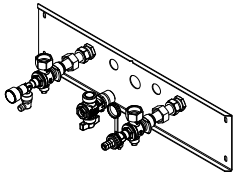

Valves/fittings for flush mounting

For gas condensing combi boiler

Part no. ZK04926

Comprising:

- Valves/fittings, heating flow/heating return
- Valves/fittings, cold water/DHW
- Boiler drain & fill valve

- Air vent valve
- Pressure gauge
- Gas shut-off valve with thermally activated safety shut-off valve
- Mounting plate, flush mounting

Connections (male thread)

Gas shut-off valve	R	3/4
Heating flow/heating return	R	3/4
Cold water/DHW	R	1/2

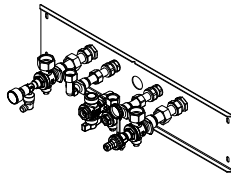

Sub-mounting kit with mixer

- For gas condensing system boiler

Part no. ZK04304

- For gas condensing combi boiler

Part no. ZK04928

For surface mounting

Comprising:

- Plate heat exchanger for system separation of the heating circuit with mixer
- Variable speed high efficiency circulation pump for the heating circuit with mixer
- 3-way mixer with mixer motor
- Mixer PCB, capable of communicating with the control unit via PlusBus
- Valve for regulating the flow rates of both heating circuits
- Adjustable bypass
- Flow temperature sensor
- Cover with same design as the wall mounted boiler
- Installation template for quick and easy installation

Note

Order a pre-plumbing jig separately in addition to the sub-mounting kit.

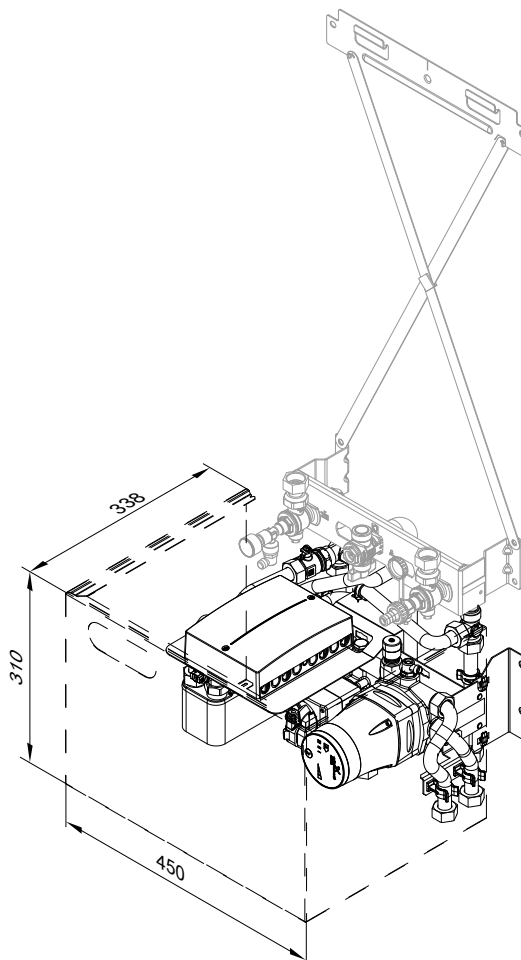

Sub-mounting kit accessories

Flow indicator

Part no. 7438927

To display the flow rate in the unregulated heating circuit with hydraulic balancing of the heating circuits.

Contact temperature limiter

Part no. 7425493

Maximum temperature limiter for underfloor heating circuits. With connecting cable, 1.5 m long.

Installation accessories (cont.)

Specification – sub-mounting kit with mixer

Assembly for heat distribution via one heating circuit with mixer and one heating circuit without mixer, with same design as the wall mounted boiler. For installation below the boiler.

The heating circuit without mixer is supplied by the integral circulation pump of the Vitodens. Installation scheme for operation with the sub-mounting kit: See www.viessmann-schemes.com.

The sub-mounting kit can only be used in conjunction with the surface mounted pre-plumbing jig.

Not in conjunction with the Vitocell 100-W DHW cylinder, type CUGA/CUGA-A below the boiler.

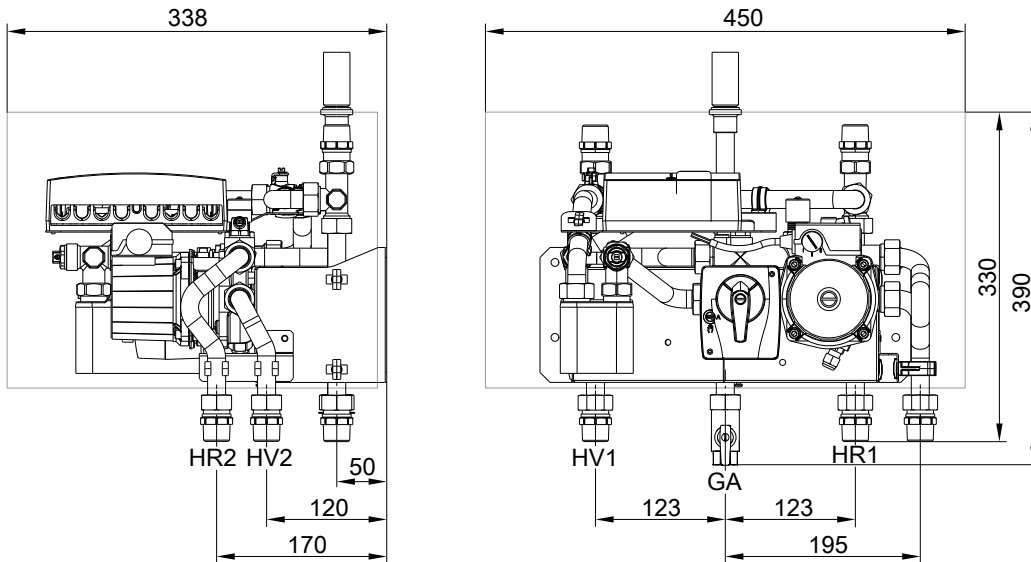

GA Gas connection R $\frac{3}{4}$

HR1 Heating return, heating circuit without mixer R $\frac{3}{4}$

HR2 Heating return, heating circuit with mixer R $\frac{3}{4}$

HV1 Heating flow, heating circuit without mixer R $\frac{3}{4}$

HV2 Heating flow, heating circuit with mixer R $\frac{3}{4}$

Max. transferable heating output of the heating circuit with mixer (ΔT 10 K)	kW	14
Max. flow rate of the heating circuit with mixer (ΔT 10 K)	l/h	1200
Permiss. operating pressure	bar	3
	MPa	0.3
Max. power consumption (total)	W	48
Dim. a	mm	400
Weight (incl. packaging)	kg	17

Residual head of the integral circulation pump for the heating circuit with mixer

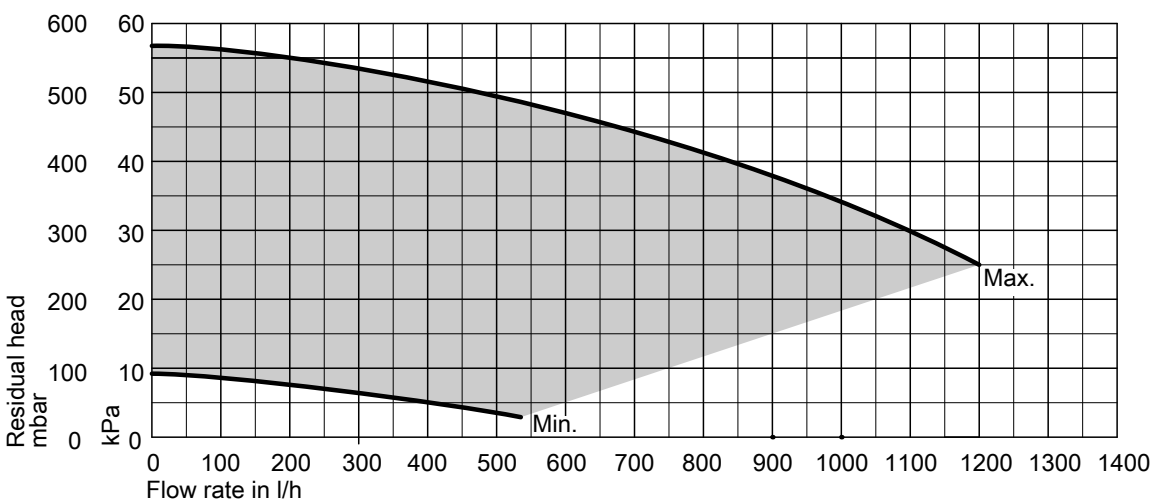

5853906

Installation accessories (cont.)

Calculating the transferable heating output (examples)

The sub-mounting kit is equipped with an integral balancing valve. This allows the flow rate via the plate heat exchanger to the regulated heating circuit to be restricted as required.

The max. heating output that can be transferred via the plate heat exchanger of the sub-mounting kit is 14 kW. To achieve balanced flow rates between the regulated heating circuit (sub-mounting kit) and the unregulated heating circuit (radiator heating circuit), the pressure drop in the sub-mounting kit must be increased. The integral balancing valve is used for this purpose.

For accurate adjustment of the flow rates, a flow indicator (available as an accessory) can be installed in the flow line of the unregulated heating circuit. The nominal circulating water volume of the boiler (see specification), minus the flow rate through the plate heat exchanger of the sub-mounting kit, results in the flow rate of the unregulated heating circuit.

Example:

Vitodens 200-W, 1.9 - 25 kW

- Nominal circulating water volume at ΔT 20 K: 1076 l/h
- Heating output for regulated heating circuit (assumed): 13 kW
- Resulting flow rate, primary side, plate heat exchanger at ΔT 20 K: 560 l/h
- Flow rate of unregulated heating circuit (to be adjusted via the balancing valve): $1076 \text{ l/h} - 560 \text{ l/h} = 516 \text{ l/h}$

Mounting frame

Mounting frame

For gas condensing system boiler

Part no. ZK04308

Comprising:

- Fixings
- Valves/fittings, heating flow/heating return
- Boiler drain & fill valve
- Air vent valve
- Pressure gauge
- Gas shut-off valve with thermally activated safety shut-off valve

Wall clearance 90 mm

Connections (male thread)		
Gas shut-off valve	R	$\frac{3}{4}$
Heating flow/heating return	R	$\frac{3}{4}$

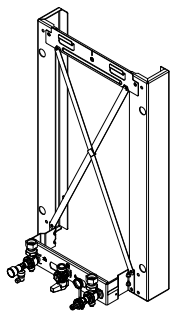

Mounting frame

For gas condensing system boiler

Part no. ZK04921

Comprising:

- Fixings
- Valves/fittings, heating flow/heating return with pipe bend
- Boiler drain & fill valve
- Air vent valve
- Pressure gauge
- Gas shut-off valve

Wall clearance 90 mm

Connections

Gas shut-off valve (male thread)	R	$\frac{3}{4}$
Heating flow/heating return (external diameter)	\varnothing mm	20

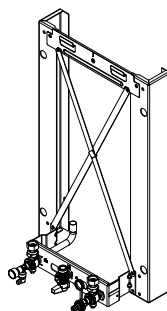

Mounting frame

For gas condensing combi boiler

Part no. ZK04922

Comprising:

- Fixings
- Valves/fittings, heating flow/heating return
- Valves/fittings, cold water/DHW
- Boiler drain & fill valve
- Air vent valve
- Pressure gauge
- Gas shut-off valve with thermally activated safety shut-off valve

Wall clearance 90 mm

Connections (male thread)		
Gas shut-off valve	R	$\frac{3}{4}$
Heating flow/heating return	R	$\frac{3}{4}$
Cold water/DHW	R	$\frac{1}{2}$

Installation accessories (cont.)

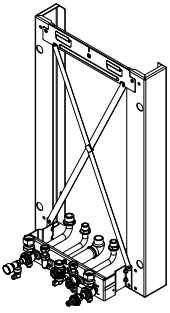

Mounting frame

For gas condensing combi boiler

Part no. ZK04923

Comprising:

- Fixings
- Valves/fittings, heating flow/heating return with pipe bend
- Valves/fittings, cold water/DHW with pipe bend
- Boiler drain & fill valve
- Air vent valve
- Pressure gauge
- Gas shut-off valve with thermally activated safety shut-off valve

Wall clearance 90 mm

Connections		
Gas shut-off valve (male thread)	R	¾
Heating flow/heating return (external diameter)	Ø mm	20
Cold water/DHW (external diameter)	Ø mm	16

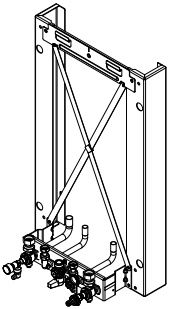

Plumbing wall mounting frame

Part no. ZK04309

Suitable for wall mounting, plumbing wall installation anywhere in the room or in front of lightweight walls.

A pre-plumbing jig (part no. ZK04307) or valves/fittings (part no. ZK04669 or ZK04670) must be ordered separately in addition to the plumbing wall mounting frame.

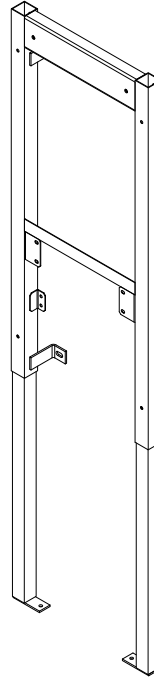

Ceiling extension for plumbing wall mounting frame

Part no. 7357904

For installation "anywhere" in the room

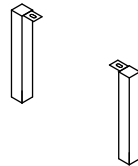

Further accessories

Hydraulic adaptor

Part no. ZK02587

For connection to on-site pipework with surface mounting

For replacing the following older appliances with the Vitodens 200-W:

- Pendola
- Vitopend (from 2004 onwards)
- Thermoblock-VC and VC 110 E/112 E
- Thermoblock-VCW
- Cerastar-ZR or Ceramini
- Cerastar-ZWR

Connection to on-site heating flow/heating return:

Connection pipes with union nuts and connection pieces Rp ¾ (female thread)

The pre-plumbing jig for surface mounting must be ordered separately.

Installation accessories (cont.)

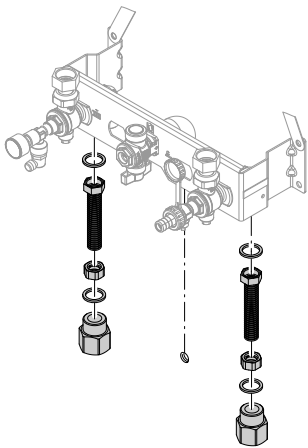

Hydraulic adaptor

Part no. ZK02588

For connection to on-site pipework with flush mounting

For replacing the following older appliances with the Vitodens 200-W:

- Pendola
- Vitopend (from 2004 onwards)
- Thermoblock-VC and VC 110 E/112 E
- Thermoblock-VCW
- Cerastar-ZR or Ceramini
- Cerastar-ZWR

Connection to on-site heating flow/heating return

Connection pipes with union nuts and connection elbows G 3/4 (male thread)

The pre-plumbing jig for surface mounting must be ordered separately.

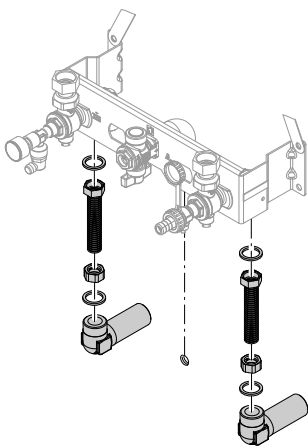

Straight-through gas valve R 1/2

Part no. ZK01989

For surface mounting

With integral, thermally activated safety shut-off valve.

Angle gas valve R 1/2

Part no. ZK01990

For flush mounting

With integral, thermally activated safety shut-off valve.

Heat meter

For installation in the connection line

Part no.	Suitable for DHW cylinders:
7172847	– Vitocell 100: Up to 500 l capacity – Vitocell 300: Up to 200 l capacity With connection accessories for G 1
7172848	– Vitocell 300: 300 to 500 l capacity With connection accessories for G 1 1/4

Components:

- Flow meter with threaded connector for capturing the flow rate.
- Temperature sensor Pt1000, connected to the heat meter, sensor lead 1.5 m long.
- G 1 or G 1 1/4 connection accessories including ball valves.

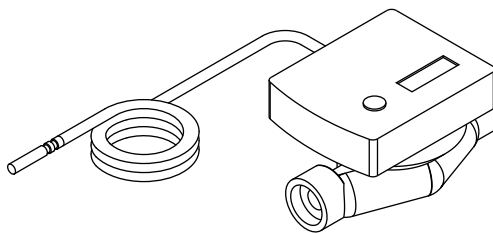

Pressure drop

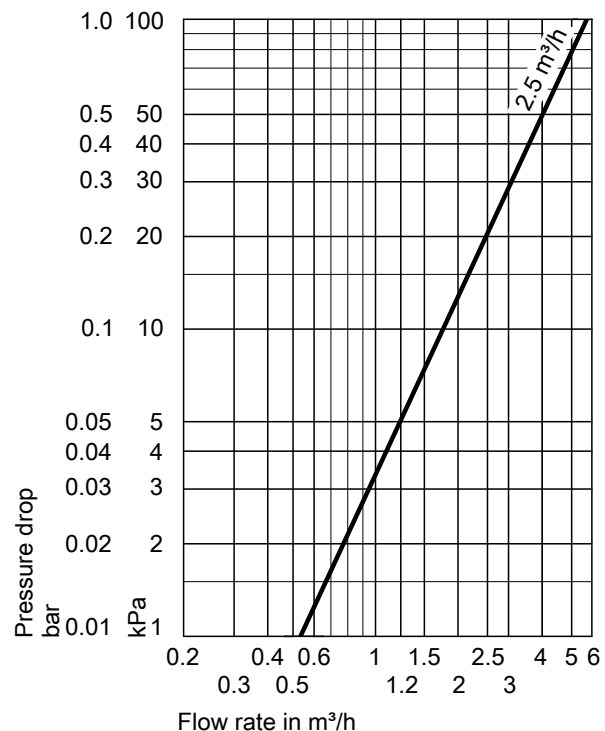

Specification

Nominal flow rate	2.5 m³/h
Lead length	1.5 m
IP rating	IP 54 to EN 60529; ensure through design/installation
Permissible ambient temperature	
– During operation	5 to 55 °C
– During storage and transport	–20 to +70 °C
Sensor type	Pt1000
Max. operating pressure	10 bar (1 MPa)

Installation accessories (cont.)

Nominal diameter	DN 20
Installed length	130 mm
Max. flow rate	5000 l/h
Minimum flow rate	
– Horizontal installation	50 l/h
– Vertical installation	50 l/h
Start-up value (for horizontal installation)	7 l/h
Battery life	Approx. 10 years

Safety assembly to DIN 1988

Comprising:

- Shut-off valve
- Non-return valve and test connector
- Pressure gauge connector
- Diaphragm safety valve
 - 10 bar (1 MPa)
 - DN 15, up to 200 l cylinder capacity
Part no. 7219722
 - DN 20, for 300 l cylinder capacity
Part no. 7180662
 - **A** 6 bar (0.6 MPa)
 - DN 15, up to 200 l cylinder capacity
Part no. 7265023
 - DN 20, for 300 l cylinder capacity
Part no. 7179666

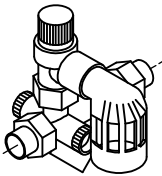

For Vitocell 100-W below the boiler

- 10 bar (1 MPa), DN 15, right angle version
Part no. 7180097
- **A** 6 bar (0.6 MPa), DN 15, right angle version
Part no. 7179457

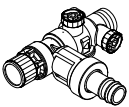

Pressure reducer (DN 15)

Part no. 7180148

To match right angle version of the safety assembly

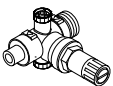

Drain outlet kit

Part no. 7459591

Drain outlet with trap and rose. For connecting the drain lines of the safety valves and the condensate drain.

Drain connection G 1

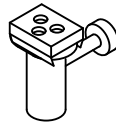

Valve/fittings cover

Part no. ZK04310

Cannot be used in conjunction with a DHW cylinder below the boiler

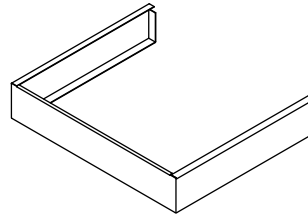

Neutralising system with wall mounting bracket

Part no. ZK03652

With neutralising granulate

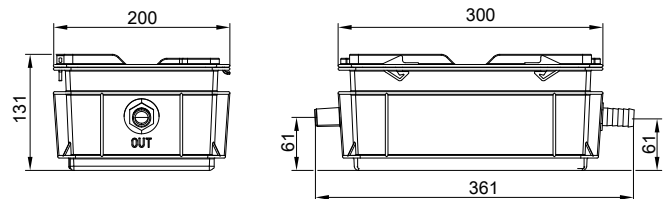

Neutralising granulate

Part no. ZK03654

2.5 kg

To match the neutralising system, part no. ZK03652

Condensate removal pump SI1800

Part no. ZK02486

Automatic condensate removal pump for condensate with a pH value ≥ 2.8 from gas condensing boilers

Components:

- Condensate container 2.0 l
- Centrifugal pump
- Non-return valve
- Connecting cable (1.5 m long) for fault messages
- Power cable (1.5 m long) with plug
- 4 connection apertures \varnothing 30 mm for condensate drain with connection piece \varnothing max. 40 mm
- Drain hose \varnothing 10 mm (5 m long)

Installation accessories (cont.)

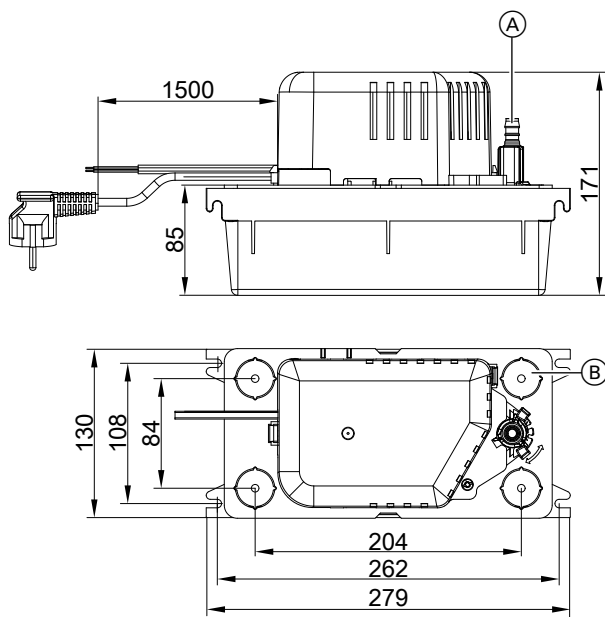

- (A) Condensate drain
- (B) 4 x condensate inlet (closed in delivered condition)

Specification

Rated voltage	230 V~
Rated frequency	50 Hz

Power consumption	70 W
IP rating	IP 20
Permissible medium temperature	+65 °C
Max. delivery head	50 kPa
Max. pump rate	500 l/h
Alarm contact	Changeover contact (floating), breaking capacity 250 V/4 A

Ventilation air cover

Part no. ZK04940

For parallel connection of flue pipe and ventilation air pipe
 \varnothing 60/60 mm without parallel adaptor.

Water spray protection

Part no. 7590109

To ensure adherence to the required protection class. Must be ordered separately for open flue operation.

Small softening system for heating water

For filling heating circuits
 See Vitoset pricelist

Tool kit

Part no.: ZK04569

For maintenance and service
 Case with all tools required for maintenance and service: Screwdriver, extension and inserts

Connections between the Vitodens and the DHW cylinder

Connection set for Vitocell 100-W DHW cylinder, type CUGA and CUGA-A below the boiler, with connection pipes
Part no. ZK04709

Comprising:

- Cylinder temperature sensor
- Connection pipes on the heating water side
- Connection pipes on the DHW side

Surface or flush mounting

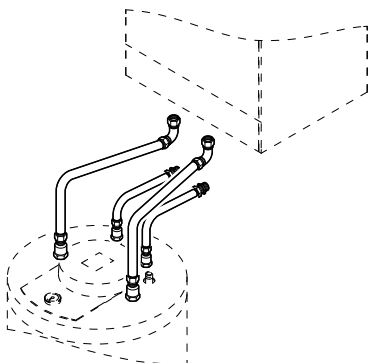

Connection set for Vitocell 100-W and 200-W DHW cylinders adjacent to the boiler

Comprising:

- Cylinder temperature sensor
 - Connection fittings
- DHW cylinder to the **left or right** of the Vitodens
- Threaded fitting version

Part no. ZK04710

- Solder version

Part no. ZK04711

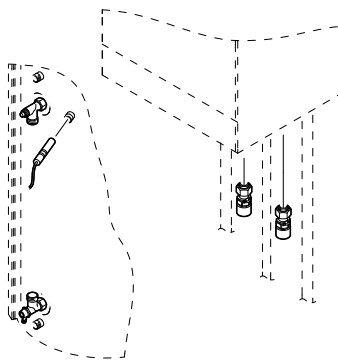

7.2 Installation accessories for Vitodens 222-W

Pre-plumbing jigs

Pre-plumbing jig for surface mounting

Part no. ZK04929

Comprising:

- Fixings
- Valves/fittings, heating flow/heating return
- Diaphragm safety valve 10 bar (1 MPa)
- Valves/fittings, cold water/DHW
- Boiler drain & fill valve
- Air vent valve
- Pressure gauge
- Gas shut-off valve with thermally activated safety shut-off valve

Connections (male thread)

Gas shut-off valve	R	¾
Heating flow/heating return	R	¾
Cold water/DHW	R	½

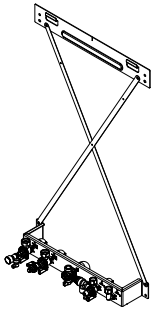

- Diaphragm safety valve 10 bar (1 MPa)
- Valves/fittings, cold water/DHW
- Boiler drain & fill valve
- Air vent valve
- Pressure gauge
- Gas shut-off valve

Connections (male thread)

Gas shut-off valve	R	¾
Heating flow/heating return (external diameter)	Ø mm	20
Cold water/DHW (external diameter)	Ø mm	16

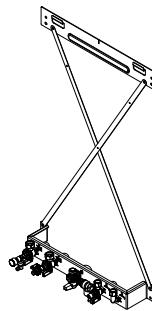

Pre-plumbing jig for surface mounting

Part no. ZK04930

Comprising:

- Fixings
- Valves/fittings, heating flow/heating return

Mounting frame

Mounting frame for surface mounting

Part no. ZK04931

Comprising:

- Fixings
- Valves/fittings, heating flow/heating return
- Diaphragm safety valve 10 bar (1 MPa)
- Valves/fittings, cold water/DHW
- Boiler drain & fill valve
- Air vent valve
- Pressure gauge
- Gas shut-off valve with thermally activated safety shut-off valve

Wall clearance 90 mm

Connections (male thread)

Gas shut-off valve	R	¾
Heating flow/heating return	R	¾
Cold water/DHW	R	½

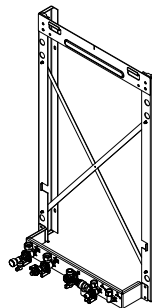

Mounting frame for surface mounting

Part no. ZK04932

Comprising:

- Fixings
- Valves/fittings, heating flow/heating return
- Diaphragm safety valve 10 bar (1 MPa)
- Valves/fittings, cold water/DHW

Installation accessories (cont.)

- Boiler drain & fill valve
- Air vent valve
- Pressure gauge
- Gas shut-off valve

Connections (male thread)		
Gas shut-off valve	R	$\frac{3}{4}$
Heating flow/heating return (external diameter)	Ø mm	20
Cold water/DHW (external diameter)	Ø mm	16

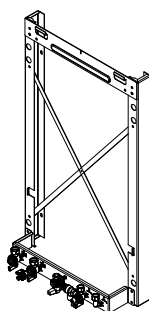

Valves/fittings

Valves/fittings for surface mounting

Part no. ZK04933

Comprising:

- Valves/fittings, heating flow/heating return
- Diaphragm safety valve 10 bar (1 MPa)
- Valves/fittings, cold water/DHW
- Boiler drain & fill valve
- Air vent valve
- Pressure gauge
- Gas shut-off valve with thermally activated safety shut-off valve

Connections (male thread)		
Gas shut-off valve	R	$\frac{3}{4}$
Heating flow/heating return	R	$\frac{3}{4}$
Cold water/DHW	R	$\frac{1}{2}$

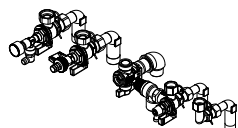

Valves/fittings for flush mounting

Part no. ZK04934

Comprising:

- Valves/fittings, heating flow/heating return
- Diaphragm safety valve 10 bar (1 MPa)
- Valves/fittings, cold water/DHW
- Boiler drain & fill valve
- Air vent valve
- Pressure gauge
- Gas shut-off valve with thermally activated safety shut-off valve
- Mounting plate, flush mounting

Connections (male thread)		
Gas shut-off valve	R	$\frac{3}{4}$
Heating flow/heating return	R	$\frac{3}{4}$
Cold water/DHW	R	$\frac{1}{2}$

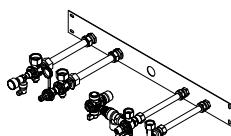

Sub-mounting kit with mixer

Surface mounting

Sub-mounting kit

Part no. ZK04935

Comprising:

- Plate heat exchanger for system separation of the heating circuit with mixer
- Variable speed high efficiency circulation pump for the heating circuit with mixer
- 3-way mixer with mixer motor
- Mixer PCB, capable of communicating with the control unit via PlusBus
- Valve for regulating the flow rates of both heating circuits
- Adjustable bypass
- Flow temperature sensor
- Cover with same design as the wall mounted boiler
- Installation template for quick and easy installation

Note

Order a pre-plumbing jig separately in addition to the sub-mounting kit.

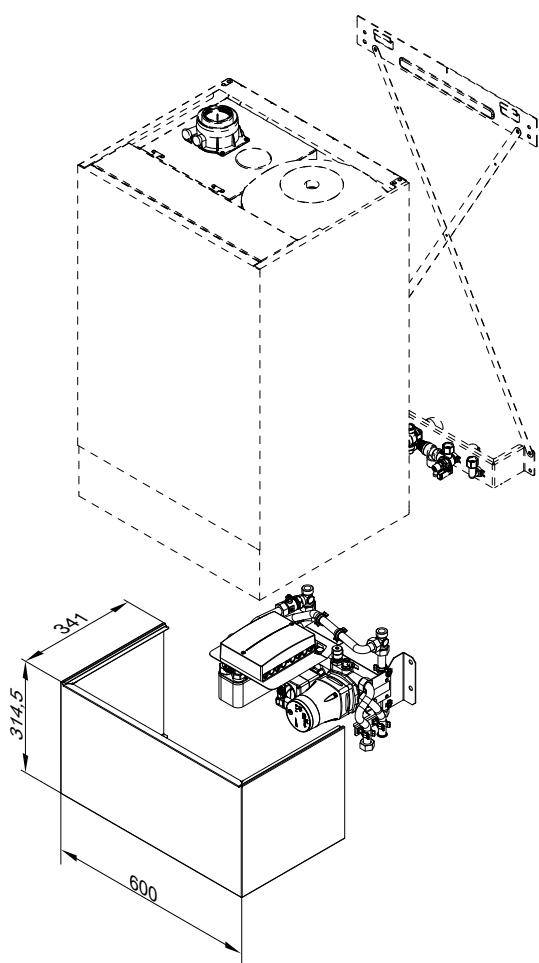

Sub-mounting kit accessories

Flow indicator

Part no. 7438927

To display the flow rate in the unregulated heating circuit with hydronic balancing of the heating circuits.

Contact temperature limiter

Part no. 7425493

Maximum temperature limiter for underfloor heating circuits. With connecting cable, 1.5 m long.

Specification – sub-mounting kit with mixer

Assembly for heat distribution via one heating circuit with mixer and one heating circuit without mixer, with same design as the wall mounted boiler. For installation below the boiler.

Comprising:

The heating circuit without mixer is supplied by the integral circulation pump of the Vitodens 222-W. Installation scheme for operation with the sub-mounting kit: See www.viessmann-schemes.com.

Installation accessories (cont.)

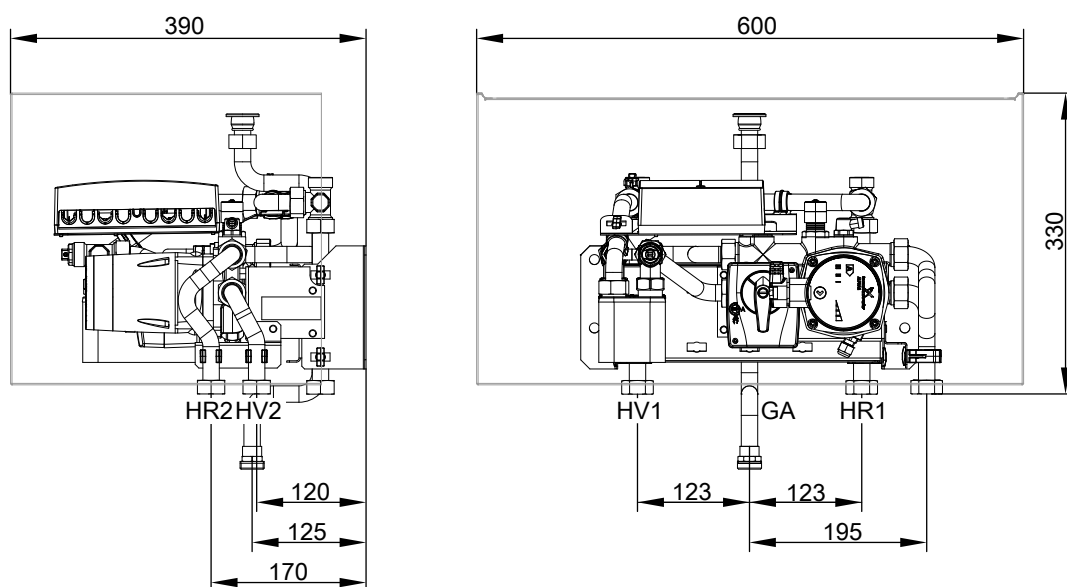

GA Gas connection Rp ½

HR1 Heating return, heating circuit without mixer R ¾

HR2 Heating return, heating circuit with mixer R ¾

HV1 Heating flow, heating circuit without mixer R ¾

HV2 Heating flow, heating circuit with mixer R ¾

Max. transferable heating output of the heating circuit with mixer (ΔT 10 K)	kW	14
Max. flow rate of the heating circuit with mixer (ΔT 10 K)	l/h	1200
Permiss. operating pressure	bar	3
	MPa	0.3
Max. power consumption (total)	W	48
Weight (incl. packaging)	kg	17

Residual head of the integral circulation pump for the heating circuit with mixer

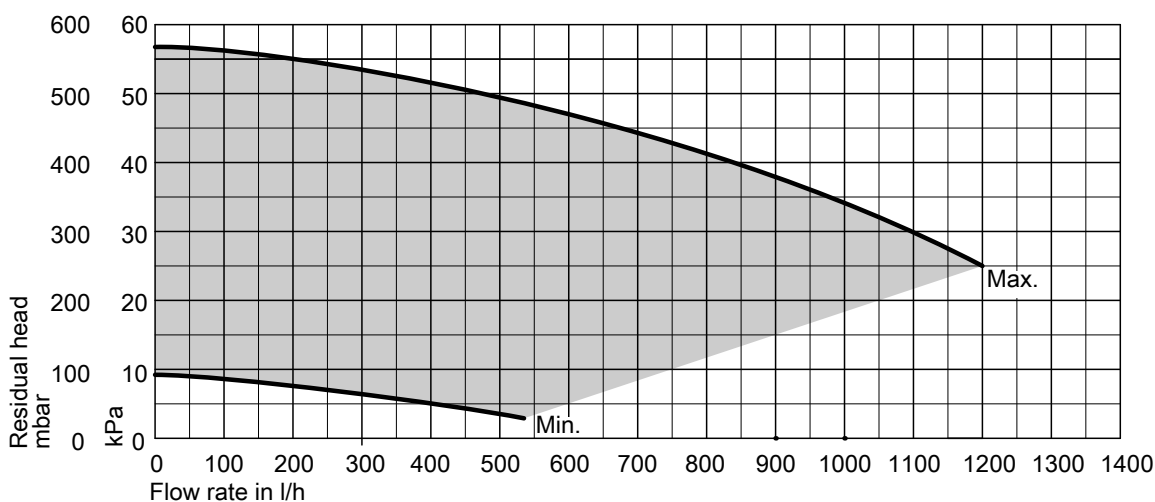

Calculating the transferable heating output (examples)

The sub-mounting kit is equipped with an integral balancing valve. This allows the flow rate via the plate heat exchanger to the regulated heating circuit to be restricted as required.

The max. heating output that can be transferred via the plate heat exchanger of the sub-mounting kit is 14 kW. To achieve balanced flow rates between the regulated heating circuit (sub-mounting kit) and the unregulated heating circuit (radiator heating circuit), the pressure drop in the sub-mounting kit must be increased. The integral balancing valve is used for this purpose.

Installation accessories (cont.)

For accurate adjustment of the flow rates, a flow indicator (available as an accessory) can be installed in the flow line of the unregulated heating circuit. The nominal circulating water volume of the boiler (see specification), minus the flow rate through the plate heat exchanger of the sub-mounting kit, results in the flow rate of the unregulated heating circuit.

Example:

Vitodens 222-W, 1.9 - 25 kW

- Nominal circulating water volume at ΔT 20 K: 1076 l/h
- Heating output for regulated heating circuit (assumed): 13 kW

- Resulting flow rate, primary side, plate heat exchanger at ΔT 20 K: 560 l/h
- Flow rate of unregulated heating circuit (to be adjusted via the balancing valve): $1076 \text{ l/h} - 560 \text{ l/h} = 516 \text{ l/h}$

Further accessories

Safety valve

Part no. ZK04936

6 bar (0.6 MPa)

For attachment to connection accessories

Only for AT

DHW expansion vessel

Part no. ZK04937

2 l capacity

Permiss. operating pressure 10 bar (1.0 MPa)

For installation in the Vitodens 222-W

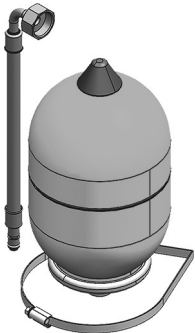

Valve/fittings cover

Part no. ZK04938

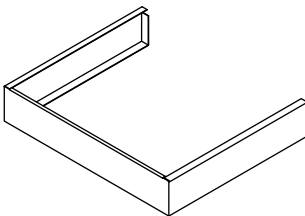

Neutralising system with wall mounting bracket

Part no. ZK03652

With neutralising granulate

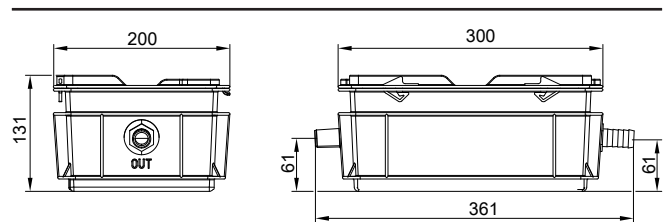

Neutralising granulate

Part no. ZK03654

2.5 kg

To match the neutralising system, part no. ZK03652

Condensate lifting system

Part no. ZK02486

Automatic condensate removal pump for condensate with a pH value of ≥ 2.8 from gas condensing boilers

Components:

- Condensate container 2.0 l
- Centrifugal pump
- Non-return valve
- Connecting cable (1.5 m long) for fault messages
- Power cable (1.5 m long) with plug
- 4 connection apertures \varnothing 30 mm for condensate drain with connector \varnothing max. 40 mm
- Drain hose \varnothing 10 mm (5 m long)

Installation accessories (cont.)

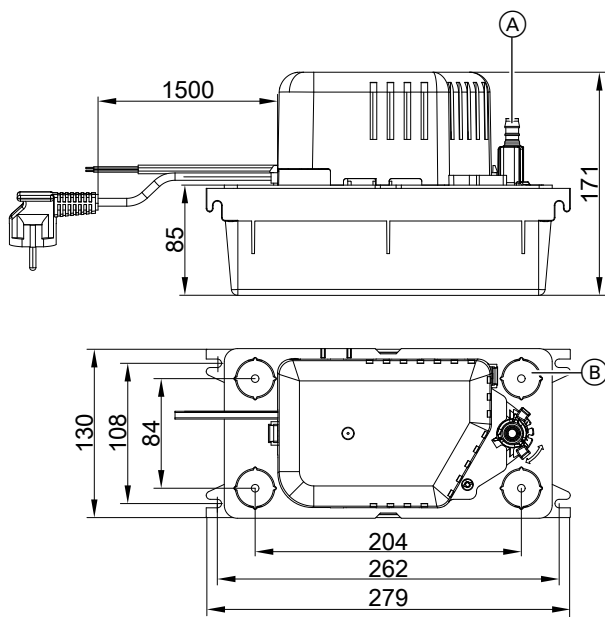

- (A) Condensate drain
- (B) 4 x condensate inlet (closed in delivered condition)

Specification

Rated voltage	230 V~
Rated frequency	50 Hz
Power consumption	70 W
IP rating	IP 20

Permissible medium temperature	+65 °C
Max. head	50 kPa
Max. pump rate	500 l/h
Alarm contact	Changeover contact (floating), breaking capacity 250 V/4 A

Ventilation air cover

Part no. ZK04940

For parallel connection of flue pipe and ventilation air pipe
 Ø 60/60 mm without parallel adaptor.

Water spray protection

Part no. 7590109

To ensure adherence to the required protection class. Must be ordered separately for open flue operation.

Plate heat exchanger flushing system

Part no. 7373005

Small softening system for heating water

For filling heating circuits
 See Vitoset pricelist

Tool kit

Part no.: ZK04569

For maintenance and service
 Case with all tools required for maintenance and service: Screwdriver, extension and inserts

Flue gas cascade (positive pressure) for multi boiler systems with Vitodens 200-W and 222-W

Comprising:

- Back draught safety device for each boiler
- Flue gas collector
- End piece with condensate drain and trap

■ Two-boiler system

- System size 110, part no. ZK01944
- System size 160, part no. Z008385

■ 3-boiler system

- System size 110, part no. ZK01945
- System size 160, part no. Z008386

■ 4-boiler system

- System size 110, part no. ZK01946
- System size 160, part no. Z008387

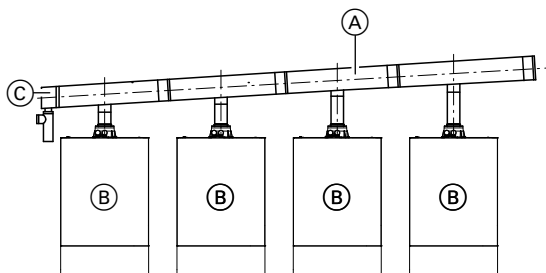

- (A) Flue gas collector
- (B) Back draught safety device (for installation in the Vitodens)
- (C) End piece with trap

7.3 Installation accessories for Vitodens 222-F

Connection set for surface mounting; upward connection

Part no. ZK04311

Components:

- Connection pipes
- Shut-off valves for heating water flow and return
- 2 connectors for DHW
- Boiler drain & fill valve
- Pressure gauge
- Gas shut-off valve with thermally activated safety shut-off valve

Connections (male thread)		
Gas	R	1/2
Heating water	R	3/4
DHW	R	1/2

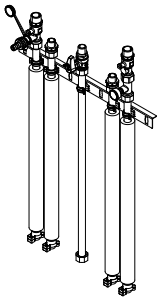

Connection set for surface mounting; connection to the left or right

Part no. ZK04312

Components:

- Connection pipes
- Shut-off valves for heating water flow and return
- 2 connectors for DHW
- Boiler drain & fill valve
- Pressure gauge
- Gas shut-off valve with thermally activated safety shut-off valve

Connections (male thread)		
Gas	R	1/2
Heating water	R	3/4
DHW	R	1/2

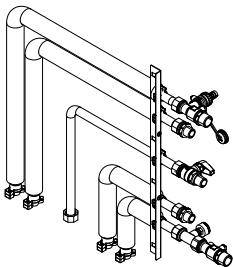

Connection set for flush mounting

Part no. ZK04313

Comprising:

- Mounting plate
- Connection pipes
- Shut-off valves for heating water flow and return
- 2 connectors for DHW
- Boiler drain & fill valve

- Pressure gauge
- Angle gas valve with thermally activated safety shut-off valve

Connections (male thread)		
Gas	R	3/4
Heating water	R	3/4
DHW	R	1/2

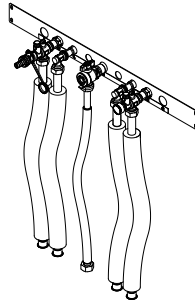

Assembly kit with mixer

Part no. ZK04324

For surface mounting

Comprising:

- Plate heat exchanger for system separation of the heating circuit with mixer
- Variable speed high efficiency circulation pump for the heating circuit with mixer
- 3-way mixer with mixer motor
- Mixer PCB, capable of communicating with the heat generator control unit via PlusBus
- Adjustable bypass
- Connection set for surface or flush mounting with:
 - Connection pipes
 - Shut-off valves for heating water flow and return
 - 2 connectors for DHW
 - Boiler drain & fill valve
 - Pressure gauge
 - Gas shut-off valve with thermally activated safety shut-off valve
- Flow temperature sensor
- Cover with same design as the boiler
- Balanced flue extension, boiler flue connection

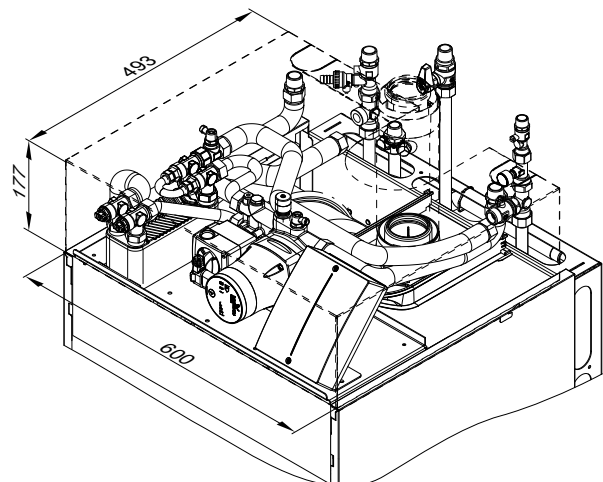

Installation accessories (cont.)

Assembly kit accessories

Line regulating valve with flow indicator

Part no. 7452078

For hydronic balancing of the heating circuits

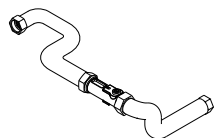

Contact temperature limiter

Part no. 7425493

Maximum temperature limiter for underfloor heating circuits

Contact temperature limiter with 1.5 m long connecting lead

Specification – assembly kit with mixer

Assembly for heat distribution via one heating circuit with mixer and one heating circuit without mixer, with same design as the boiler. For installation on the boiler.

The heating circuit without mixer is supplied by the integral circulation pump of the Vitodens. Installation scheme for operation with the assembly kit: See www.viessmann-schemes.com.

Max. transferable heating output of the heating circuit with mixer (ΔT 10 K)	kW	14
Max. flow rate of the heating circuit with mixer (ΔT 10 K)	l/h	1200
Permiss. operating pressure	bar	3
	MPa	0.3
Max. power consumption	W	48
Connections (male thread)		
– Gas	R	½
– Heating water	R	¾
– DHW	R	½
Weight (incl. packaging)	kg	20

Residual head of the integral circulation pump for the heating circuit with mixer

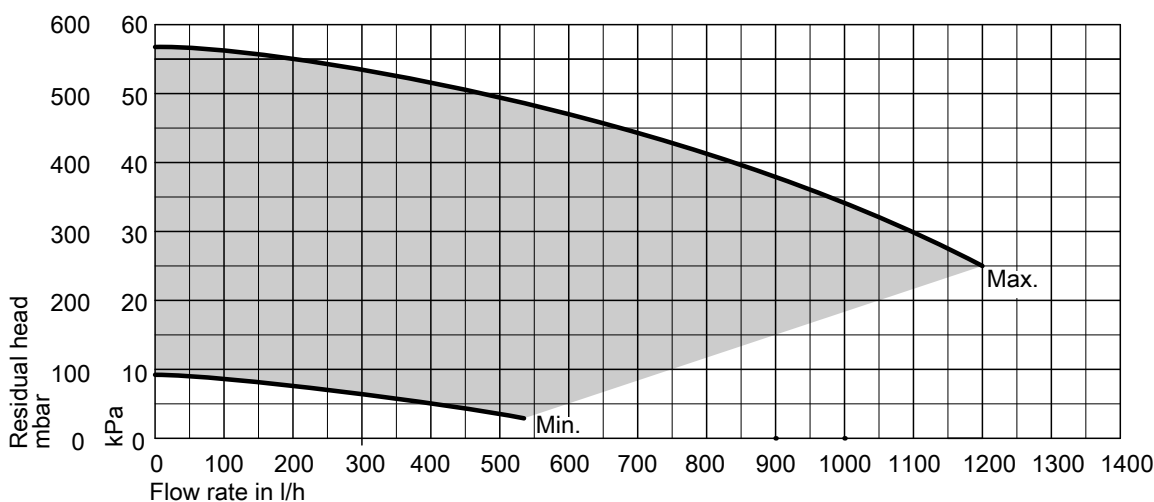

Calculating the transferable heating output (examples)

The max. heating output that can be transferred via the plate heat exchanger of the assembly kit is 14 kW. To achieve balanced flow rates between the regulated heating circuit (assembly kit) and the unregulated heating circuit (radiator heating circuit), the pressure drop in the assembly kit must be increased.

For this, the line regulating valve with flow indicator (available as an accessory) can be fitted to the primary side of the plate heat exchanger, i.e. between the flow and return. The nominal circulating water volume of the boiler (see specification), minus the flow rate through the plate heat exchanger of the assembly kit, results in the flow rate of the unregulated heating circuit.

Example:

Vitodens 222-F, 1.9 - 25 kW

- Nominal circulating water volume at ΔT 20 K: 1076 l/h
- Heating output for regulated heating circuit (assumed): 13 kW
- Resulting flow rate, primary side, plate heat exchanger at ΔT 20 K: 560 l/h (to be set via the line regulating valve)
- Flow rate of the unregulated heating circuit: 1076 l/h – 560 l/h = 516 l/h

Connection set for DHW circulation pump

Part no. ZK04314

For installation in the appliance

Components:

- High efficiency circulation pump
- Flow regulating valve
- Pipe assembly with thermal insulation

Connection R ½ (male thread)

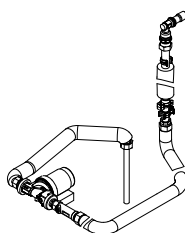

Installation accessories (cont.)

Note

Depending on the system equipment level, an EM-P1 extension (accessories) may be required to connect the DHW circulation pump. See Vitodens system schemes at www.viessmann-schemes.com

Filling device with pipe separator

Part no. 7356492

Can be combined with all connection sets and assembly kit with mixer

- For surface mounting

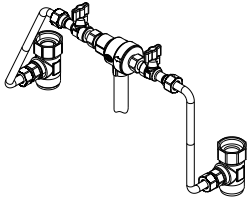

Filling device with pipe separator

Part no. 7356902

Can be combined with all connection sets and assembly kit with mixer

- For flush mounting

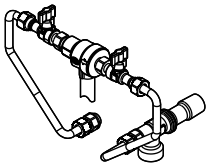

Safety assembly to DIN 1988

DN 15

Components:

- Shut-off valve
- Non-return valve and test connector
- Pressure gauge
- Diaphragm safety valve

For on-site surface mounting



- 10 bar (1.0 MPa)

Part no. 7219722

- (A) 6 bar (0.6 MPa)

Part no. 7265023

For flush mounting in conjunction with connection set

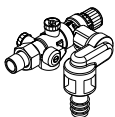

- 10 bar (1.0 MPa)

Part no. 7351842

- (A) 6 bar (0.6 MPa)

Part no. 7351840

Connection bend for condensate drain

Part no. 7461025

Connection line from the appliance: DN 20

Drain connection: DN 40

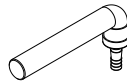

Neutralising system with wall mounting bracket

Part no. ZK03652

With neutralising granulate

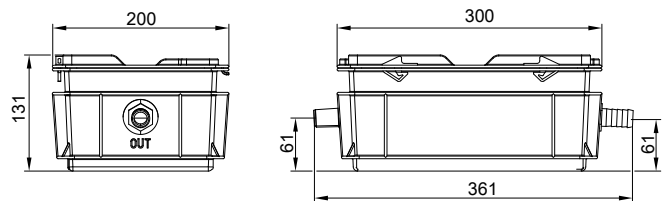

Neutralising granulate

Part no. ZK03654

2.5 kg

To match the neutralising system, part no. ZK03652

Condensate lifting system

Part no. ZK02486

Automatic condensate removal pump for condensate with a pH value of ≥ 2.8 from gas condensing boilers

Components:

- Condensate container 2.0 l
- Centrifugal pump
- Non-return valve
- Connecting cable (1.5 m long) for fault messages
- Power cable (1.5 m long) with plug
- 4 connection apertures \varnothing 30 mm for condensate drain with connector \varnothing max. 40 mm)
- Drain hose \varnothing 10 mm (5 m long)

Installation accessories (cont.)

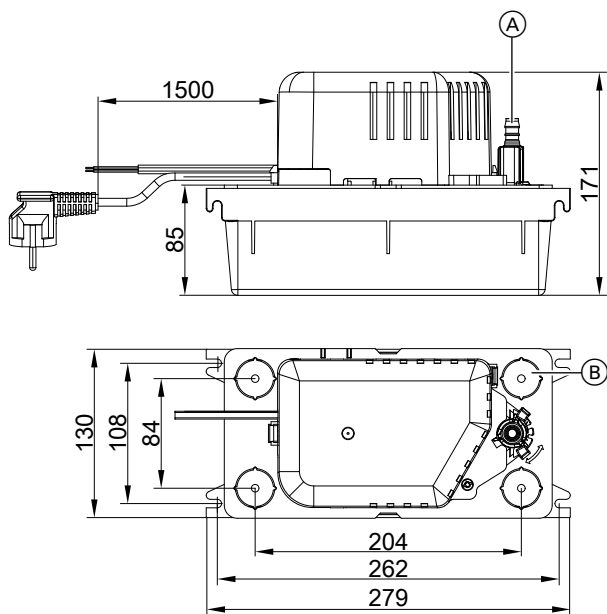

- (A) Condensate drain
 (B) 4 x condensate inlet (closed in delivered condition)

Specification

Rated voltage	230 V~
Rated frequency	50 Hz
Power consumption	70 W
IP rating	IP 20
Permissible medium temperature	+65 °C
Max. head	50 kPa
Max. pump rate	500 l/h
Alarm contact	Changeover contact (floating), breaking capacity 250 V/4 A

Boiler plinth

Part no. 7352259

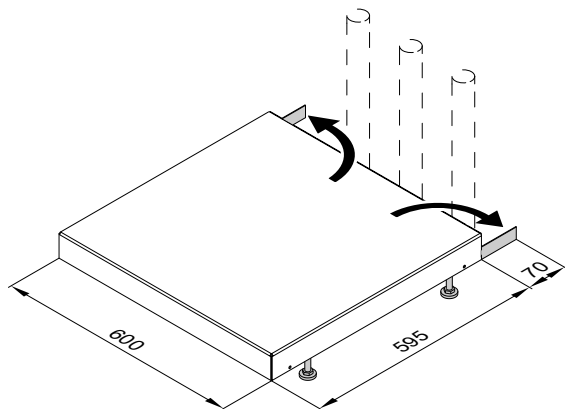

- For siting the appliance on unfinished floors
- Height adjustable, for screed heights from 10 to 18 cm
- With spacer for installation on finished walls, for downward connection

Transport aid

Part no. 7425341

To facilitate transportation of storage combi boilers

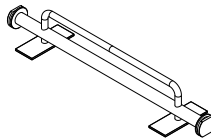

Water spray protection

Part no. 7590109

To ensure adherence to the required protection class. Must be ordered separately for open flue operation.

Small softening system for heating water

For filling heating circuits

See Vitoset pricelist.

Plate heat exchanger flushing system

Part no. 7373005

For cleaning the plate heat exchanger of the Vitodens with loading cylinder

Tool kit

Part no.: ZK04569

For maintenance and service

Case with all tools required for maintenance and service: Screwdriver, extension and inserts

7.4 Installation accessories for Vitodens 242-F

Connection set for surface mounting; upward connection Part no. ZK04316

Comprising:

- Connection pipes
- Shut-off valves for heating water flow and return
- 2 connectors for DHW
- 2 connectors (threaded) and 2 connectors (smooth pipe) for solar flow and return
- Boiler drain & fill valve
- Pressure gauge
- Gas shut-off valve with thermally activated safety shut-off valve

Connections (male thread)		
Gas	R	½
Heating water	R	¾
DHW	R	½
Solar	R	¾
	Ø mm	22

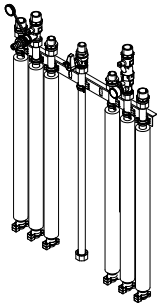

Connection set for surface mounting; connection to the left or right Part no. ZK04317

Comprising:

- Connection pipes
- Shut-off valves for heating water flow and return
- 2 connectors for DHW
- 2 connectors (threaded) and 2 connectors (smooth pipe) for solar flow and return
- Boiler drain & fill valve
- Pressure gauge
- Gas shut-off valve with thermally activated safety shut-off valve

Connections (male thread)		
Gas	R	½
Heating water	R	¾
DHW	R	½
Solar	R	¾
	Ø mm	22

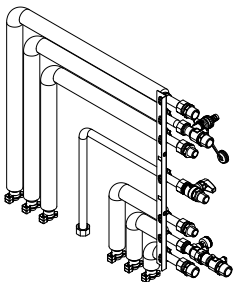

Connection set for flush mounting Part no. ZK04315

Comprising:

- Mounting plate
- Connection pipes
- Shut-off valves for heating water flow and return
- 2 connectors for DHW
- 2 connectors for solar flow and return
- Boiler drain & fill valve
- Pressure gauge
- Gas shut-off valve with thermally activated safety shut-off valve

Connections (male thread)		
Gas	R	¾
Heating water	R	¾
DHW	R	½
Solar	R	¾

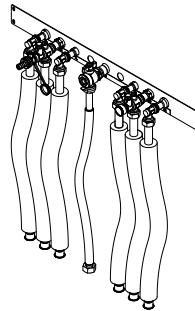

Connection set for DHW circulation pump Part no. ZK04318

For installation in the Vitodens

Comprising:

- High efficiency circulation pump
- Flow regulating valve
- Pipe assembly with thermal insulation

Connection R ½ (male thread)

For installation in the DHW circulation pipe, see page 131.

Note

Depending on the system equipment level, an EM-P1 extension (accessories) may be required to connect the DHW circulation pump. See Vitodens system schemes at www.viessmann-schemes.com

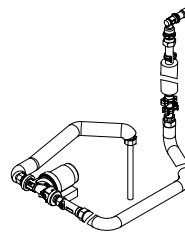

DHW circulation connection set

Part no. ZK04646

For installation in the Vitodens. For on-site installation of the DHW circulation pump.

Installation accessories (cont.)

Comprising:

- Pipe assembly with thermal insulation
- Flow regulating valve

Connection G ¾ (female thread)

For installation in the DHW circulation pipe, see page 131.

Note

If required, scald protection must be installed on site. The automatic thermostatic mixing valve (part no. 7438940) can be used.

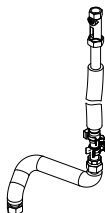

Filling device with pipe separator

Part no. 7356492

Can be combined with all connection sets and assembly kit with mixer

- For surface mounting

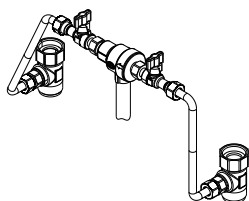

Filling device with pipe separator

Part no. 7356902

Can be combined with all connection sets and assembly kit with mixer

- For flush mounting

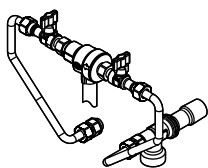

Assembly kit with mixer

Part no. ZK04295

For surface mounting

Comprising:

- Plate heat exchanger for system separation of the heating circuit with mixer
- Variable speed high efficiency circulation pump for the heating circuit with mixer
- 3-way mixer with mixer motor
- Mixer PCB, capable of communicating with the heat generator control unit via PlusBus
- Adjustable bypass

■ Connection set for surface or flush mounting with:

- Connection pipes
- Shut-off valves for heating water flow and return
- 2 connectors for DHW
- 2 connectors for solar flow and return
- Boiler drain & fill valve
- Pressure gauge
- Gas shut-off valve with thermally activated safety shut-off valve
- Flow temperature sensor
- Cover with same design as the boiler
- Balanced flue extension, boiler flue connection

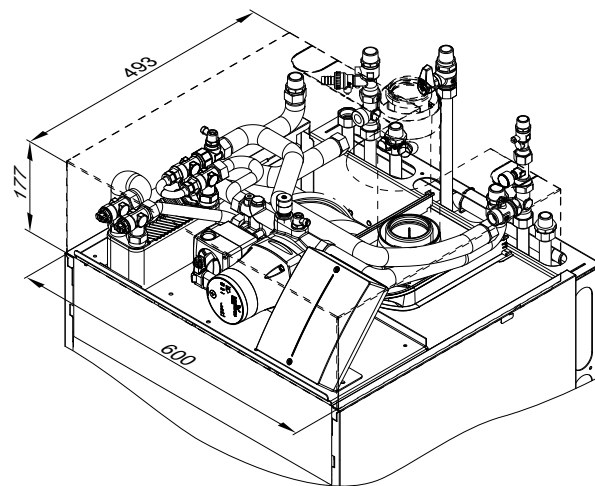

Assembly kit accessories

Line regulating valve with flow indicator

Part no. 7452078

For hydronic balancing of the heating circuits

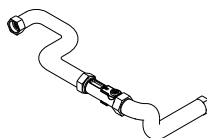

Contact temperature limiter

Part no. 7425493

Maximum temperature limiter for underfloor heating circuits
Contact temperature limiter with 1.5 m long connecting lead

Specification – assembly kit with mixer

Assembly for heat distribution via one heating circuit with mixer and one heating circuit without mixer, with same design as the boiler. For installation on the boiler.

The heating circuit without mixer is supplied by the integral circulation pump of the Vitodens. Installation scheme for operation with the assembly kit: See www.viessmann-schemes.com.

Installation accessories (cont.)

Max. transferable heating output of the heating circuit with mixer (ΔT 10 K)	kW	14
Max. flow rate of the heating circuit with mixer (ΔT 10 K)	l/h	1200
Permiss. operating pressure	bar	3
	MPa	0.3
Max. power consumption	W	48
Connections (male thread)		
– Gas	R	$\frac{1}{2}$
– Heating water	R	$\frac{3}{4}$
– DHW	R	$\frac{1}{2}$
– Solar	R	$\frac{3}{4}$
	\emptyset	22
	mm	
Weight (incl. packaging)	kg	20

Residual head of the integral circulation pump for the heating circuit with mixer

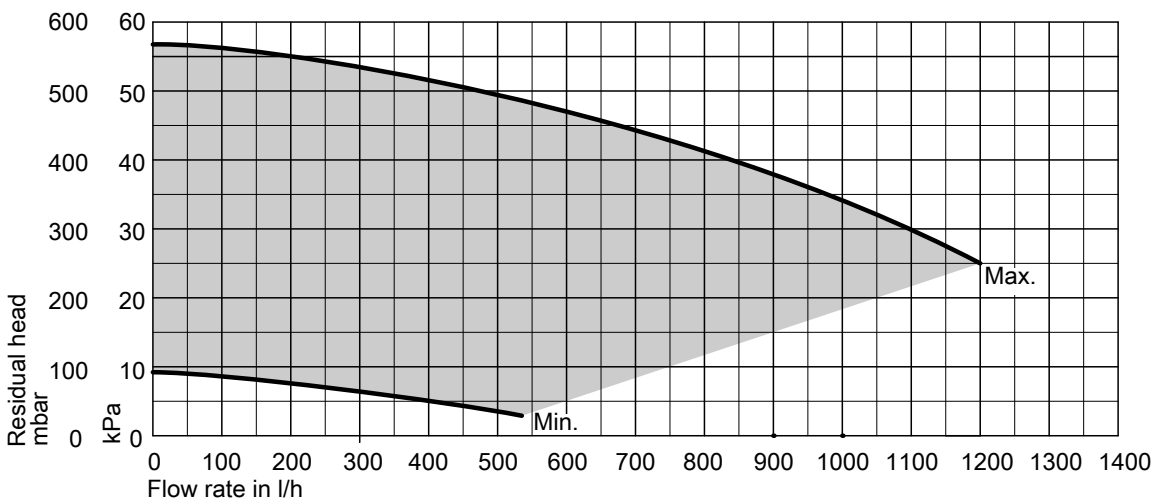

Calculating the transferable heating output (examples)

The max. heating output that can be transferred via the plate heat exchanger of the assembly kit is 14 kW. To achieve balanced flow rates between the regulated heating circuit (assembly kit) and the unregulated heating circuit (radiator heating circuit), the pressure drop in the assembly kit must be increased.

For this, the line regulating valve with flow indicator (available as an accessory) can be fitted to the primary side of the plate heat exchanger, i.e. between the flow and return. The nominal circulating water volume of the boiler (see specification), minus the flow rate through the plate heat exchanger of the assembly kit, results in the flow rate of the unregulated heating circuit.

Example:

Vitodens 242-F, 1.9 - 19 kW

- Nominal circulating water volume at ΔT 20 K: 818 l/h
- Heating output for regulated heating circuit (assumed): 13 kW
- Resulting flow rate, primary side, plate heat exchanger at ΔT 20 K: 560 l/h (to be set via the line regulating valve)
- Flow rate of the unregulated heating circuit: 818 l/h – 560 l/h = 258 l/h

Safety assembly to DIN 1988

Comprising:

- Shut-off valve
- Non-return valve and test connector
- Pressure gauge
- Diaphragm safety valve

For on-site surface mounting (DN 20)

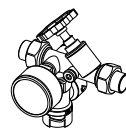

- 10 bar (1 MPa)
- Part no. 7180662

Heat transfer medium Tyfocor LS

Part no. 7159727

- 25 l in a disposable container
- Ready-mixed for temperatures down to -28°C
- Tyfocor LS can be mixed with Tyfocor G-LS.

Connection set for external heating water expansion vessel

Part no. 7301709

Expansion vessel connection: R $\frac{1}{2}$



Automatic thermostatic mixing valve

For integration in hot water systems **without** DHW circulation pipe

Part no. 7438940

Installation accessories (cont.)

- Setting range: 35 to 60 °C
- Connection: G 1 male thread

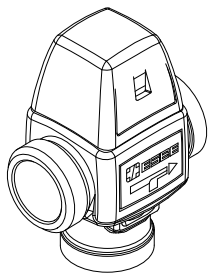

Thermostatic DHW circulation set

For integration in hot water systems with DHW circulation pipe

Part no. ZK01284

- Automatic thermostatic mixing valve
- Setting range: 35 to 60 °C
- Integral non-return valves
- Connection: R ¾ male thread
- Thermal insulation

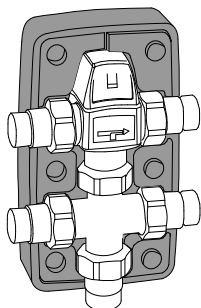

Solar pressure gauge

For installation in surface mounted and flush mounted connection sets

Part no. 7459103

- Display range: 0 to 10 bar
- With tees for installation in the connection sets

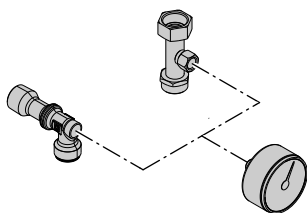

Connection bend for condensate drain

Part no. 7461025

Connection line from the appliance: DN 20

Drain connection: DN 40

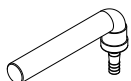

Neutralising system with wall mounting bracket

Part no. ZK03652

With neutralising granulate

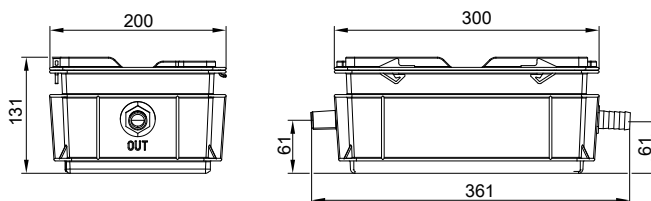

Neutralising granulate

Part no. ZK03654

2.5 kg

To match the neutralising system, part no. ZK03652

Condensate lifting system

Part no. ZK02486

Automatic condensate removal pump for condensate with a pH value of ≥ 2.8 from gas condensing boilers

Components:

- Condensate container 2.0 l
- Centrifugal pump
- Non-return valve
- Connecting cable (1.5 m long) for fault messages
- Power cable (1.5 m long) with plug
- 4 connection apertures \varnothing 30 mm for condensate drain with connector \varnothing max. 40 mm
- Drain hose \varnothing 10 mm (5 m long)

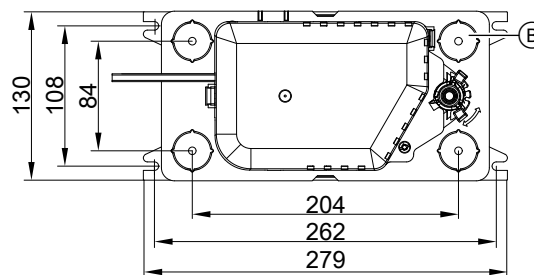
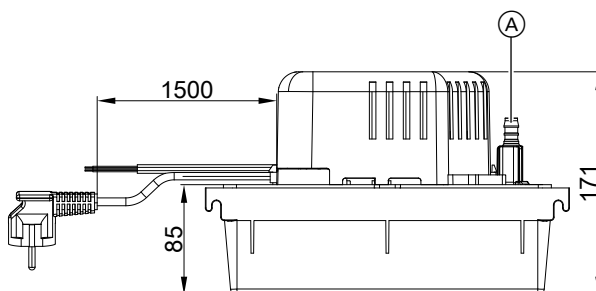

(A) Condensate drain

(B) 4 x condensate inlet (closed in delivered condition)

Specification

Rated voltage	230 V~
Rated frequency	50 Hz
Power consumption	70 W
IP rating	IP 20

Installation accessories (cont.)

Permissible medium temperature	+65 °C
Max. head	50 kPa
Max. pump rate	500 l/h
Alarm contact	Changeover contact (floating), breaking capacity 250 V/4 A

Boiler plinth

Part no. 7352259

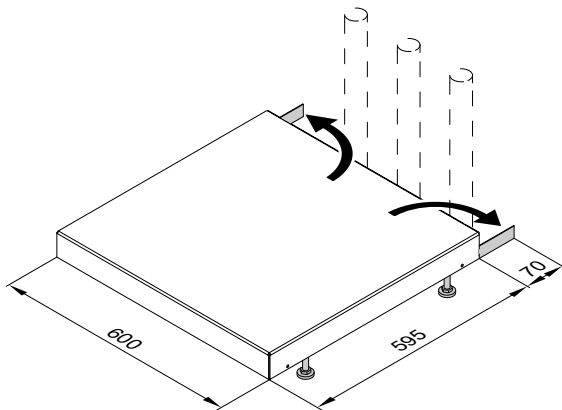

- For siting the appliance on unfinished floors
- Height adjustable, for screed heights from 10 to 18 cm
- With spacer for installation on finished walls, for downward connection

Transport aid

Part no. 7425341

To facilitate transportation of storage combi boilers

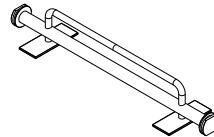

Small softening system for heating water

For filling heating circuits

See Vitoset pricelist.

Plate heat exchanger flushing system

Part no. 7373005

For cleaning the plate heat exchanger of the Vitodens with loading cylinder

Tool kit

Part no.: ZK04569

For maintenance and service

Case with all tools required for maintenance and service: Screwdriver, extension and inserts

7.5 Divicon heating circuit distributor and low loss headers

Divicon heating circuit distributor

Layout and function

- Available with R ¾, R 1 and R 1¼ connections.
- With heating circuit pump, check valve, ball valves with integral thermometers and 3-way mixer or without mixer.
- Quick and simple installation due to pre-assembled unit and compact design.
- All-round thermal insulation shells for low radiation losses.
- High efficiency pumps and optimised mixer curve ensure low electricity costs and precise control characteristics.
- The bypass valve for hydraulic balancing of the heating system is available as an accessory and is provided as a threaded component for inserting into the prepared hole in the cast body.
- Individually wall mounted or with a double or triple manifold.
- Also available as a kit. For further details see the Viessmann pricelist.

For part numbers in conjunction with the different circulation pumps, see the Viessmann pricelist.

The dimensions of the heating circuit distributor are the same, with or without mixer.

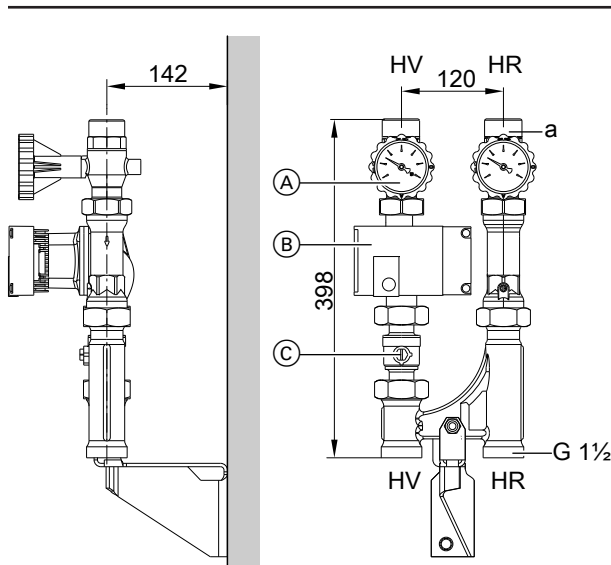

Divicon without mixer (wall mounting, shown without thermal insulation)

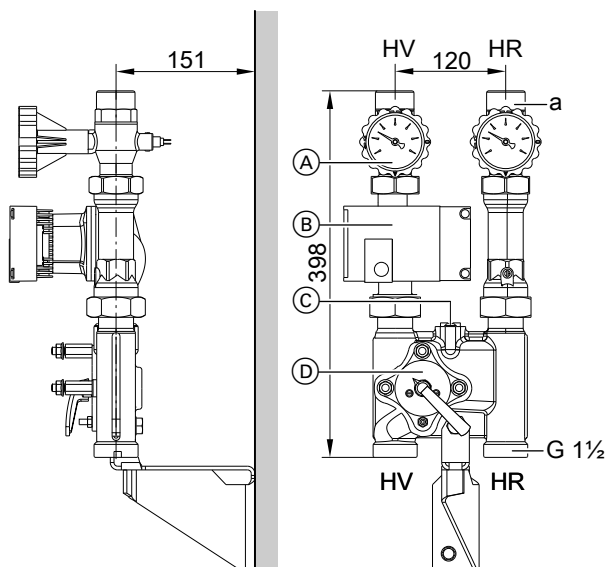

Divicon with mixer (wall mounting, shown without thermal insulation or mixer drive extension kit)

- HR Heating return
- HV Heating flow
- (A) Ball valves with thermometer (as programming unit)
- (B) Circulation pump
- (C) Bypass valve (accessories)
- (D) Mixer-3

- HR Heating return
- HV Heating flow
- (A) Ball valves with thermometer (as programming unit)
- (B) Circulation pump
- (C) Ball valve

Heating circuit connection	R	¾	1	1¼
Flow rate (max.)	m ³ /h	1.0	1.5	2.5
a (female)	Rp	¾	1	1¼
a (male)	G	1¼	1¼	2

Heating circuit connection	R	¾	1	1¼
Flow rate (max.)	m ³ /h	1.0	1.5	2.5
a (female)	Rp	¾	1	1¼
a (male)	G	1¼	1¼	2

Installation accessories (cont.)

Installation example: Divicon with triple manifold

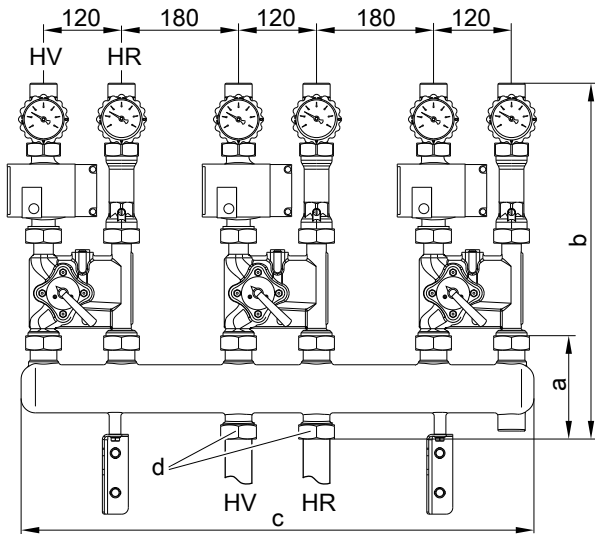

(shown without thermal insulation)

HR Heating return
HV Heating flow

Dimension	Manifold with heating circuit connection	
	R ¾ and R 1	R 1¼
a	135	183
b	535	583
c	784	784
d	G 1¼	G 2

Determining the required nominal diameter

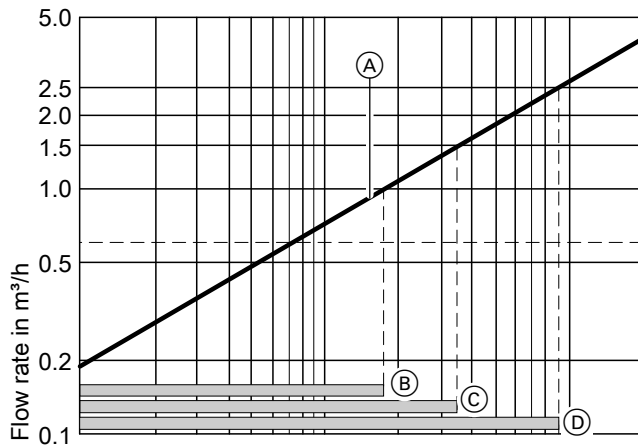

Mixer control characteristics

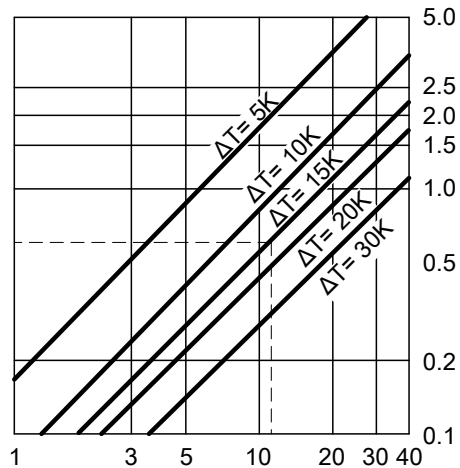

Heating circuit output in kW

- Ⓐ Divicon with mixer-3
The operating ranges marked Ⓑ to Ⓓ provide optimum control characteristics with the Divicon mixer:
- Ⓑ Divicon with mixer-3 (R ¾)
Application range: 0 to 1.0 m³/h
- Ⓒ Divicon with mixer-3 (R 1)
Application range: 0 to 1.5 m³/h
- Ⓓ Divicon with mixer-3 (R 1¼)
Application range: 0 to 2.5 m³/h

Example:

Heating circuit for radiators with a heating output of $\dot{Q} = 11.6$ kW
Heating system temperature 75/60 °C ($\Delta T = 15$ K)

- c Specific thermal capacity
- \dot{m} Mass flow rate
- \dot{Q} Heating output
- \dot{V} Flow rate

5853906

Installation accessories (cont.)

$$\dot{Q} = \dot{m} \cdot c \cdot \Delta T \quad c = 1.163 \frac{\text{Wh}}{\text{kg} \cdot \text{K}} \quad \dot{m} \hat{=} \dot{V} \quad (1 \text{ kg} \approx 1 \text{ dm}^3)$$

$$\dot{V} = \frac{\dot{Q}}{c \cdot \Delta T} = \frac{11600 \text{ Wh} \cdot \text{kg} \cdot \text{K}}{1.163 \text{ Wh} \cdot (75-60) \text{ K}} = 665 \frac{\text{kg}}{\text{h}} \hat{=} 0.665 \frac{\text{m}^3}{\text{h}}$$

Select the smallest possible mixer within the application limit with the value \dot{V} .

Circulation pump curves and pressure drop on the heating water side

The residual pump head results from the differential between the selected pump curve and the pressure drop curve of the respective heating circuit distributor or further components (pipe assembly, distributor, etc.).

The following pump graphs show the pressure drop curves of the different Divicon heating circuit distributors.

Maximum flow rate for Divicon:

- With R ¾ = 1.0 m³/h
- With R 1 = 1.5 m³/h
- With R 1¼ = 2.5 m³/h

Example:

Flow rate $\dot{V} = 0.665 \text{ m}^3/\text{h}$

Selected:

- Divicon with mixer R ¾
- Wilo Yonos PARA 25/6 circulation pump, variable differential pressure operating mode and set to maximum delivery head
- Pump rate 0.7 m³/h

Head of the relevant pump

curve: 48 kPa
 Divicon pressure drop: 3.5 kPa
 Residual head: 48 kPa – 3.5 kPa = 44.5 kPa.

Note

For further components (pipe assembly, distributor, etc.) determine the pressure drop and deduct it from the residual head.

Differential pressure-dependent heating circuit pumps

According to the [German] Energy Saving Ordinance (EnEV), circulation pumps in central heating systems must be sized in accordance with current technical rules.

Ecodesign Directive 2009/125/EC requires high efficiency circulation pumps to be used throughout Europe from 1 January 2013, if the pumps are not installed in the heat generator.

Design information

The use of differential pressure-dependent heating circuit pumps requires heating circuits with variable pump rates. These include e.g. single and twin line heating systems with thermostatic valves and underfloor heating systems with thermostatic or zone valves.

Result of this example: Divicon with mixer-3 (R ¾)

Wilo Yonos PARA 25/6

- Particularly power saving, high efficiency circulation pump
- Energy efficiency index EEI ≤ 0.20

Operating mode: Constant differential pressure

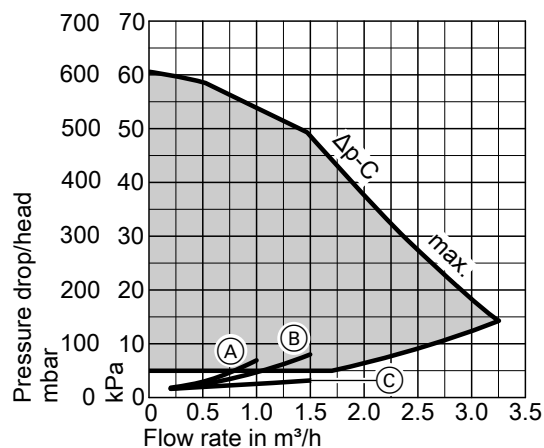

- (A) Divicon R ¾ with mixer
- (B) Divicon R 1 with mixer
- (C) Divicon R ¾ and R 1 without mixer

Operating mode: Variable differential pressure

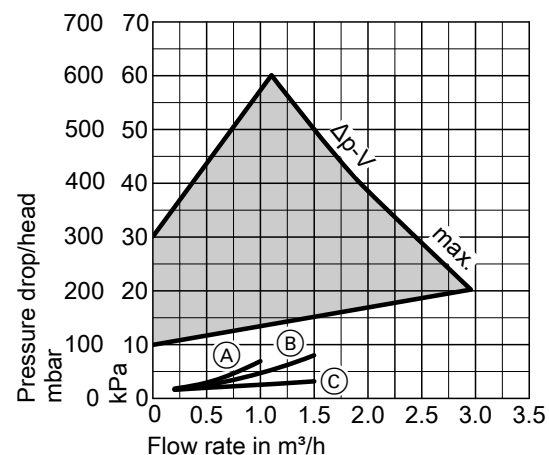

- (A) Divicon R ¾ with mixer
- (B) Divicon R 1 with mixer
- (C) Divicon R ¾ and R 1 without mixer

Installation accessories (cont.)

Wilo Yonos PARA Opt. 25/7.5

Operating mode: Constant differential pressure

- Energy efficiency index EEI ≤ 0.21

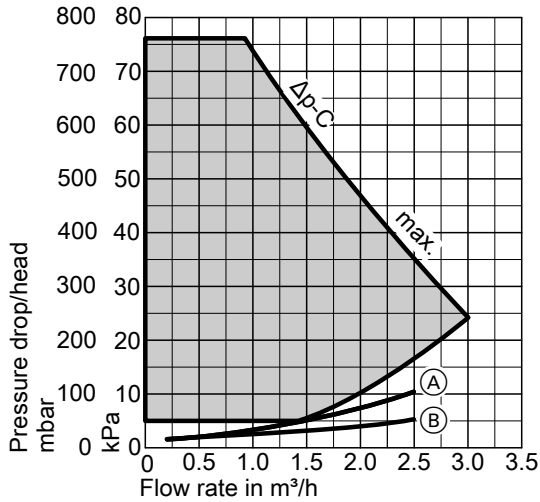

- (A) Divicon R 1 1/4 with mixer
- (B) Divicon R 1 1/4 without mixer

Operating mode: Variable differential pressure

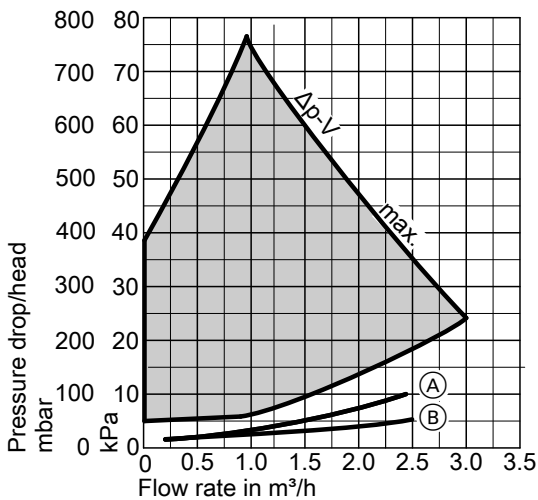

- (A) Divicon R 1 1/4 with mixer
- (B) Divicon R 1 1/4 without mixer

Grundfos Alpha 2.1 25-60

- With power consumption display
- With Autoadapt function (automatic matching to the pipework)
- With night setback function
- Energy efficiency index EEI ≤ 0.20

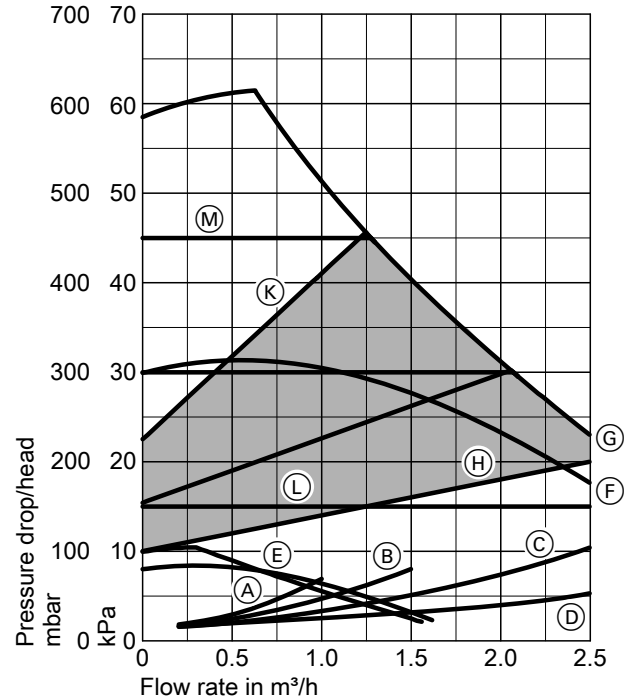

- (A) Divicon R 3/4 with mixer
- (B) Divicon R 1 with mixer
- (C) Divicon R 1 1/4 with mixer
- (D) Divicon R 3/4, R 1 and R 1 1/4 without mixer
- (E) Stage 1
- (F) Stage 2
- (G) Stage 3
- (H) Min. proportional pressure
- (K) Max. proportional pressure
- (L) Min. constant pressure
- (M) Max. constant pressure

Bypass valve

Part no. 7464889

For hydraulic balancing of the heating circuit with mixer. To be inserted into the Divicon.

Installation accessories (cont.)

Manifold

Incl. thermal insulation.

For wall mounting with separately ordered wall mounting bracket.

The connection between boiler and manifold must be made on site.

For 2 Divicon

Part no. **7460638** for Divicon R $\frac{3}{4}$ and R 1

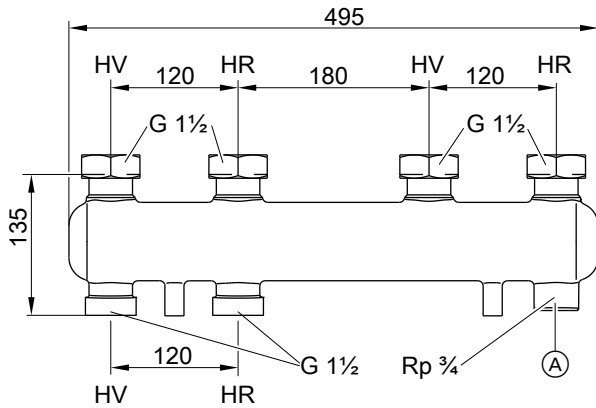

(A) Connection option for expansion vessel

HV Heating water flow

HR Heating water return

Part no. **7466337** for Divicon R $1\frac{1}{4}$.

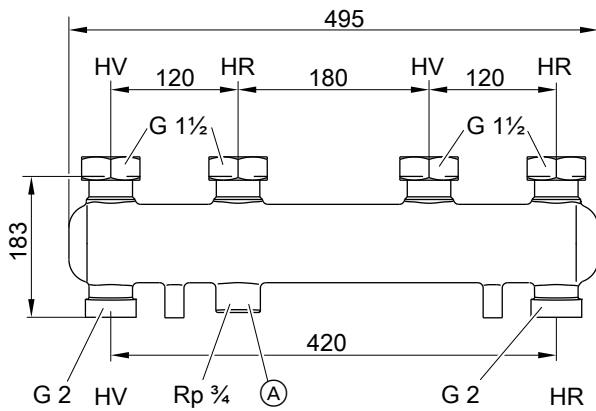

(A) Connection option for expansion vessel

HV Heating water flow

HR Heating water return

Pressure drop

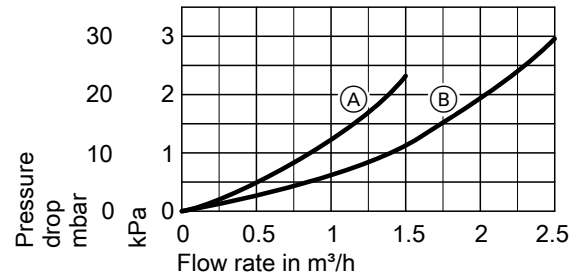

(A) Manifold for Divicon R $\frac{3}{4}$ and R 1

(B) Manifold for Divicon R $1\frac{1}{4}$

Installation accessories (cont.)

For 3 Divicon

Part no. **7460643** for Divicon R ¾ and R 1

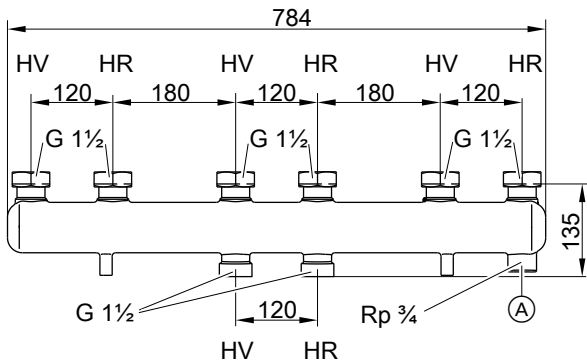

- (A) Connection option for expansion vessel
 HV Heating water flow
 HR Heating water return

Part no. **7466340** for Divicon R 1¼

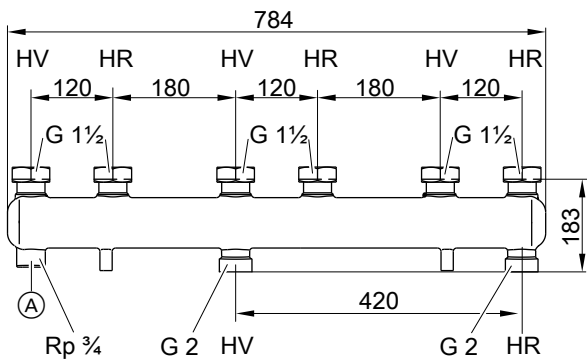

- (A) Connection option for expansion vessel
 HV Heating water flow
 HR Heating water return

Wall mounting bracket

Part no. **7465894**

For individual Divicon.

With screws and rawl plugs.

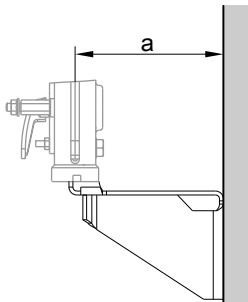

For Divicon	With mixer	Without mixer
a mm	151	142

Pressure drop

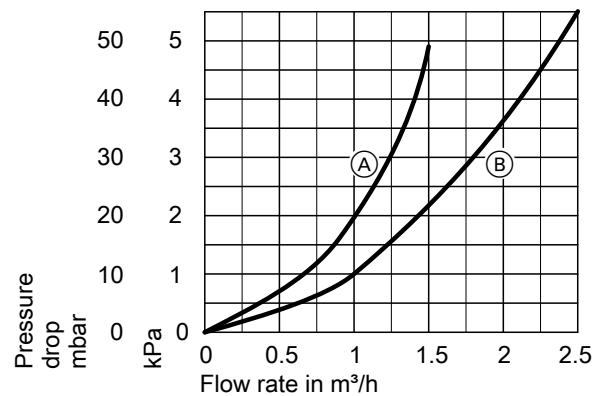

- (A) Manifold for Divicon R ¾ and R 1
 (B) Manifold for Divicon R 1¼

Part no. **7465439**

For manifold.

With screws and rawl plugs.

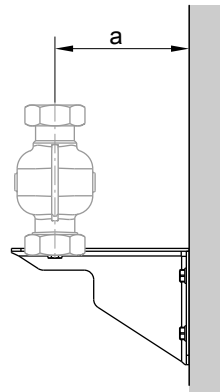

For Divicon	R ¾ and R 1	R 1¼
a mm	142	167

Installation accessories (cont.)

Low loss header

Part no. 7460649

Max. flow rate 4.5 m³/h.

With thermal insulation and integral sensor well.

The connection between boiler and low loss header must be made on site.

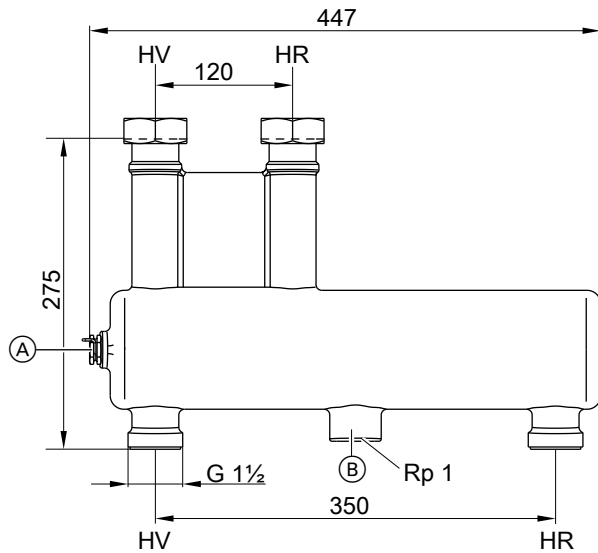

- (A) Sensor well
- (B) Optional blow-down
- HV Heating water flow
- HR Heating water return

Pressure drop

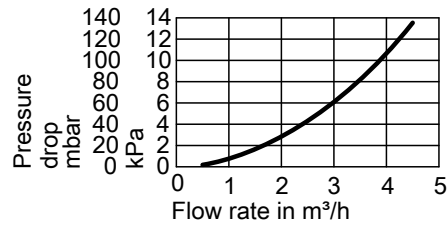

Part no. 7460648

Max. flow rate 7.5 m³/h.

With thermal insulation and integral sensor well.

The connection between boiler and low loss header must be made on site.

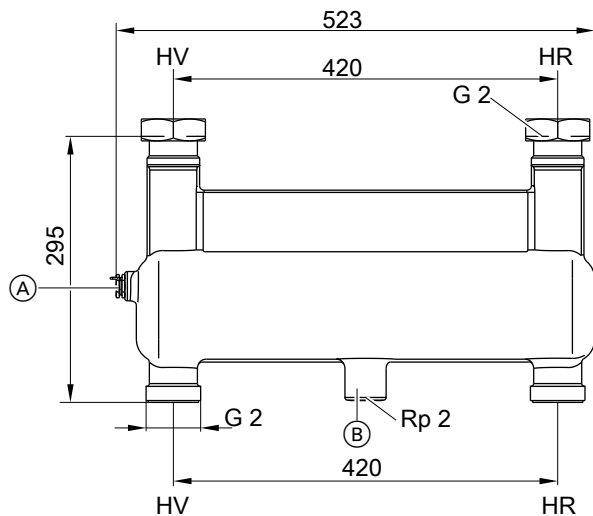

Pressure drop

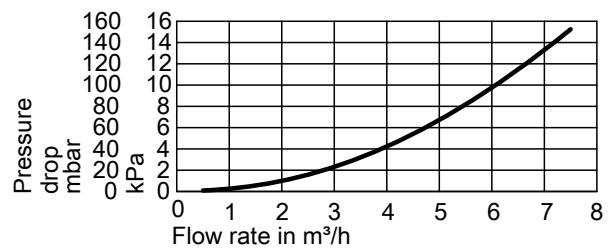

Installation accessories (cont.)

Low loss headers

Low loss header, type Q70

Part no. ZK03679

- Flow rate up to 3 m³/h
 - R 1 female connector
 - 3 female connections Rp 1/2 for air vent valve, drain outlet and sensor well
 - With air vent valve and sensor well for temperature sensor
 - With EPP thermal insulation to EnEV
- The connection to the heat generator is made on site.

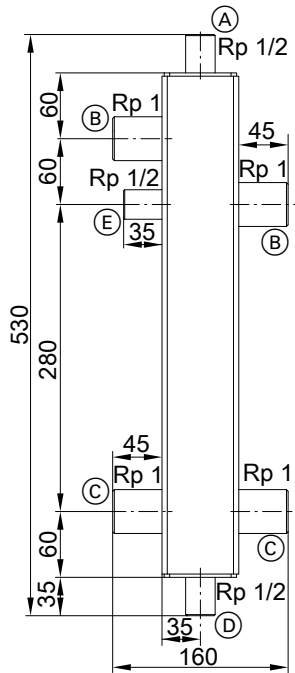

- (A) Ventilation Rp 1/2
- (B) Heating water flow R 1 female thread
- (C) Heating water return R 1 female thread
- (D) Drain Rp 1/2
- (E) Sensor well Rp 1/2

Wall mounting bracket for low loss header, type Q70

Part no. ZK03682

With fixing materials

Pressure drop

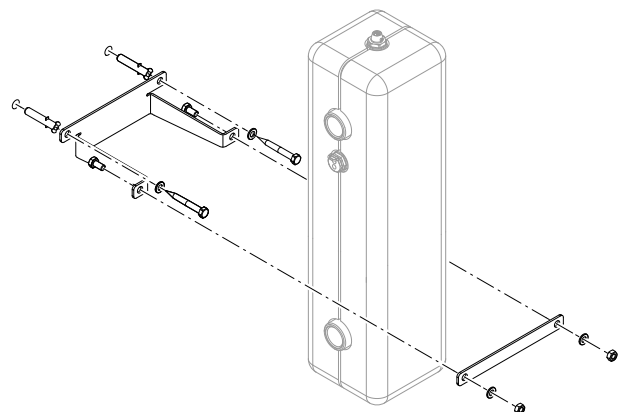
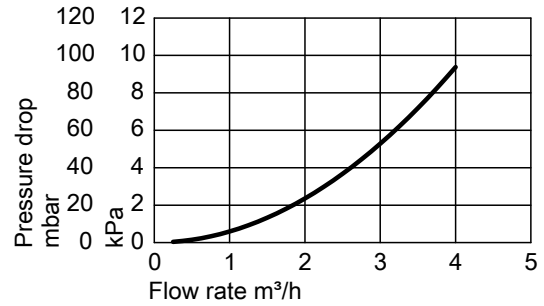

8.1 Siting, installation

Siting conditions for open flue operation (appliance type B)

Type B₂₃ and B₃₃

In rooms where **air contamination from halogenated hydrocarbons or organosilicon compounds (e.g. siloxanes)** may occur, such as hairdressing salons, printing shops, chemical cleaners, laboratories, etc., the Vitodens may only be operated as a room sealed system.

If in doubt, please consult us.

Never install the Vitodens in areas subject to very dusty conditions. The installation location must be kept free from frost and must be adequately ventilated.

Provide a condensate drain and a discharge pipe for the safety valve in the installation room.

The max. ambient temperature of the system must not exceed 35 °C.

If these instructions are not observed, any consequential appliance damage directly related to any of these causes is excluded from our warranty.

- (A) When installing in Austria, observe all current safety regulations as defined by ÖVGW-TR Gas (G1), ÖNORM, ÖVGW, ÖVE and locally applicable standards.

Multi boiler systems with flue systems under negative pressure

Systems with several Vitodens with separate hydraulic connections require a flue gas cascade suitable for negative pressure or individual flue gas routing for each boiler.

Installation room

Permissible:

- Siting gas equipment on the same floor
- Living space with interconnected room air supply
- Ancillary rooms with interconnected room air supply (larders, basements, utility rooms, etc.)
- Ancillary rooms with vents to the outside: Ventilation air/extract air 150 cm² or 2 × 75 cm² each at the top and bottom of the same wall, up to 35 kW
- Attic rooms, but only with adequate minimum chimney height, acc. to DIN 18160 – 4 m above inlet (negative pressure operation).

Not permissible:

- Stairwells and communal hallways. Exception: In detached and two-family houses of low height, top edge of floor in the top storey < 7 m above ground level.
- Bathrooms and toilets without outside windows with shaft ventilation
- Rooms where explosive or flammable materials are stored
- Rooms that are ventilated mechanically or via individual duct systems to DIN 18117-1

Observe all local fire regulations.

Connection on the flue gas side

The connection piece to the chimney should be as short as possible. Therefore position the Vitodens as close to the chimney as possible. The flue should be designed to be as straight as possible. If bends are unavoidable, do not arrange these one after the other. The entire flue gas path must be able to be checked and cleaned as required. No special protective measures or clearances towards combustible objects, such as furniture, packaging or similar, need to be taken/observed. The surface temperatures of the Vitodens and the flue system do not exceed 85 °C at any point.

For further details, see the technical guide on flue systems for the Vitodens.

Extractors

When installing appliances with extraction to the outside (cooker hoods, extractor fans, etc.), ensure that air extraction will not create negative pressure inside the installation room. A return flow of flue gases could result if the ventilation system and the Vitodens are operated simultaneously. In such cases, install an **interlock circuit**.

Safety equipment for the installation room

Viessmann heat generators are tested and approved in accordance with all safety regulations and are therefore fail-safe. Unpredictable external factors may, in the rarest of cases, lead to the potentially harmful escape of carbon monoxide (CO). For this case, we recommend using a CO limiter.

Siting conditions for room sealed operation (appliance type C)

Type C_{13x}, C_{14(3x)}, C_{33x}, C_{43x}, C_{53x}, C_{63x}, C_{83x} or C_{93x} according to TRGI 2018

The Vitodens can be installed for **room sealed** operation **independent** of the size and ventilation of the installation room.

Installation room

Suitable siting locations include:

- Recreational rooms and other living spaces
- Unventilated ancillary rooms
- Cabinets (open at the top)
- Recesses without compulsory clearance towards combustible materials
- Attic rooms (pitched attics and long panes) where the balanced flue pipe can be routed directly through the roof

The installation room must be free from the risk of frost.

The max. ambient temperature of the system must not exceed 35 °C.

Provide a condensate drain and a discharge pipe for the safety valve in the installation room.

Electrical interlocks for extractors (extractor hoods, etc.) are not required with room sealed operation.

Connection on the flue gas side

The flue should be designed to be as short and straight as possible. If bends are unavoidable, do not install them directly one after another. The entire flue gas path must be able to be checked and cleaned as required.

Since the flue pipe connection for room sealed operation is surrounded by combustion air (coaxial pipe), no clearances towards combustible materials need be maintained.

Ventilation air ducts with which oil or solid fuel boilers were previously used must not contain any sulphur or soot deposits on the inner surfaces.

Sulphur and soot deposits cause operating faults.

If thorough cleaning is not possible, a balanced flue pipe must be laid through the shaft. Alternatively, lay separate ventilation air and flue gas pipes.

Viessmann accepts no liability for damages caused by a failure to observe these stipulations.

Close off and seal any other connection apertures with appropriate materials.

This does not apply to any cleaning or inspection apertures that are provided with chimney cleaning covers and that are identified with an appropriate test mark.

For further details, see the technical guide on flue systems for the Vitodens.

Design information (cont.)

Balanced flue system for multiple connections C_{14(3x)}

For connecting multiple flues to a single balanced flue chimney (balanced flue system, positive pressure)

With a positive pressure C_{14(3x)} multiple connection, the boilers may only be operated with natural gas. A back draught safety device must be installed in the flue gas connection and in the mixing shaft of the burner for each boiler.

For further details, see the technical guide on flue systems for the Vitodens.

Using third party flue systems

Any approved flue system can be used for type C₆. These flue systems are not tested together with the boilers and do not have system certification in accordance with the Gas Appliances Regulation 2016/426/EC. When using, follow the Viessmann design specifications in the flue system technical guide for appliance types C_{13x}, C_{33x}, C_{53x}, C_{83x}, C_{93x} and observe appliance-specific information.

Siting the Vitodens 222-F and 242-F in recesses

When delivered, the ON/OFF switch and the electrical connections are located on the left-hand side of the appliance. When installing in recesses, ensure that access is guaranteed. Recommended wall clearance min. 100 mm. Otherwise relocate the ON/OFF switch and electrical connections accordingly. The ON/OFF switch can be relocated to the right-hand side or the top. The electrical connections can be relocated to the right-hand side.

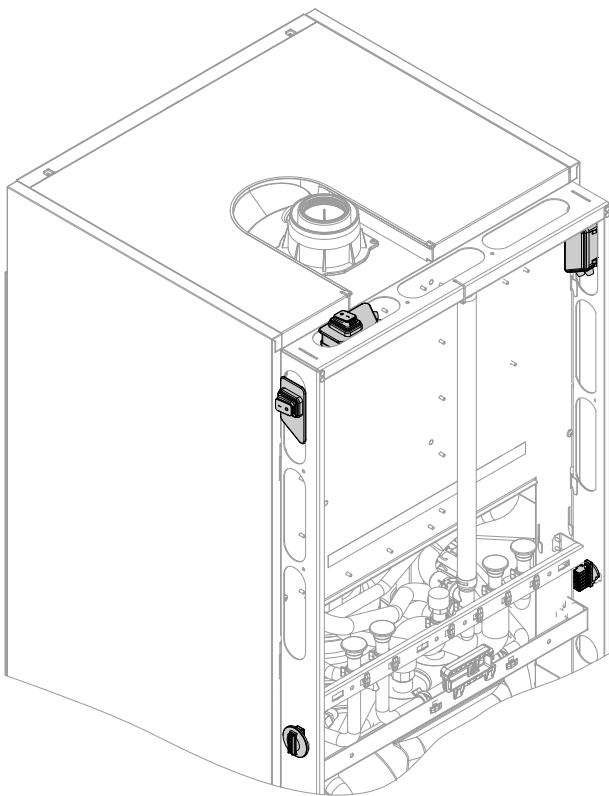

If aluminium flue pipes are used, a condensate trap must additionally be installed above the boiler flue connection.

Safety equipment for the installation room

Viessmann heat generators are tested and approved in accordance with all safety regulations and are therefore fail-safe. Unpredictable external factors may, in the rarest of cases, lead to the potentially harmful escape of carbon monoxide (CO). For this case, we recommend using a CO limiter.

Operation of the Vitodens in wet rooms

Room sealed operation

- The Vitodens is approved for installation in wet rooms
- Vitodens 200-W, 222-F, 242-F: Protection rating IP X4 splashproof
The boiler may be installed in safety zone 1 if hosed water (e.g. from massage showers) is prevented.
- Vitodens 222-W: Protection rating IP X1
The boiler must not be installed in safety zone 1 or 2.

Open flue operation

- The Vitodens 200-W, 222-F and 242-F may only be installed in safety zone 1 or 2 if additional splash protection (part no. 7590109) is fitted.
- The Vitodens 222-F and 242-F in conjunction with the assembly kit, and the Vitodens 222-W, have protection rating IP X1. These systems must not be installed in safety zones 1 or 2.

Design information (cont.)

When installing the Vitodens in wet rooms, observe the safety zones and minimum wall clearances according to VDE 0100 [or local regulations] (see also "Electrical safety zone").

Electrical safety zone

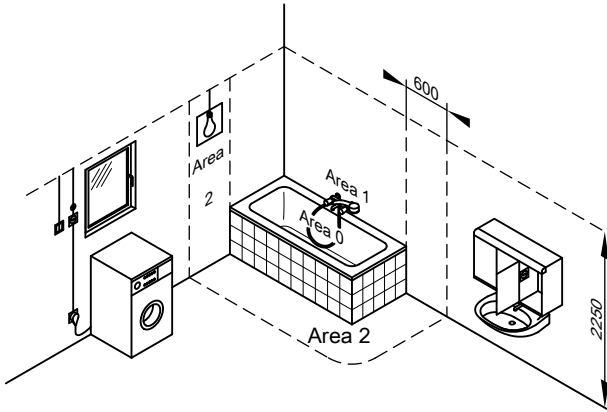

Electrical equipment in rooms containing a bathtub or a shower must be installed in such a way that users cannot be exposed to dangerous body currents. VDE 0100 specifies that cables supplying permanently installed consumers in zones 1 and 2 should only be run vertically and routed into the equipment from the back.

Electrical connection

The power supply must comply with the requirements of your local power supply utility and current VDE [or local] regulations (Ⓐ: ÖVE regulations).

Protect the power cable with a fuse with a max. rating of 16 A. We recommend installing an AC/DC-sensitive RCD (RCD class B) for DC (fault) currents that can occur with energy efficient equipment.

Make the power supply (230 V~, 50 Hz) via a permanent connection.

Flexible connecting cable included in standard delivery:

- Vitodens 200-W and 222-W: Approx. 2 m long
- Vitodens 222-F and 242-F: Approx. 1.5 m long

It can be connected via an on-site junction box outside the appliance.

The power supply for the accessories is connected at the terminals in the appliance. The cables are inserted into the boiler through the underside (Vitodens 200-W and 222-W) or the back (Vitodens 222-F and 242-F).

The outside temperature sensor, cylinder temperature sensor (Vitodens 200-W) and PlusBus to the accessories are connected to an external plug:

- Vitodens 200-W and 222-W: Plug on the underside
- Vitodens 222-F and 242-F: Plug on the left of the frame; can be changed to the right

Recommended cables

NYM 3 G 1.5 mm²

- Power cables (accessories)
- DHW circulation pump

2-core min. 0.75 mm²

- EM-EA1, EM-P1, EM-S1 (PlusBus) extension
- Outside temperature sensor
- Extension kit for heating circuit with mixer (PlusBus)
- Vitotrol 200-E (PlusBus)

Interlock switch

Install an interlock for open flue operation if an extractor (e.g. cooker hood) is fitted in the room providing the combustion air supply. The EM-EA1 extension (accessories) can be used for this. This switches any extractors off when the burner is started.

Power supply for accessories

The power supply for accessories can be provided directly at the control unit.

This connection is switched by the system ON/OFF switch.

If the total system current exceeds 6 A, connect one or more extensions directly to the mains supply via an ON/OFF switch.

Where the boiler is sited in a wet room, the power supply connection of accessories must not be made at the control unit.

Additional requirements when siting boilers operated with LPG in rooms below ground level

According to TRF 1996 Vol. 2 – valid as of 1 September 1997 – an external safety solenoid valve is no longer required when installing the Vitodens below ground level.

However, the high safety standard derived from the use of an external safety solenoid valve has proved to be valuable. We therefore recommend the continued installation of an external safety solenoid valve when installing the Vitodens in rooms below ground level. The EM-EA1 extension (accessories) is required for this.

Gas connection

Gas installations must only be carried out by a registered gas fitter authorised by the relevant gas supply utility.

Connect and size the mains gas according to TRGI 2018 or TRF 1996 [or local regulations].

- Ⓐ Connect the mains gas according to ÖVGW-TR Gas (G1) and the regionally applicable building regulations.

Max. test pressure 150 mbar (15 kPa).

We recommend installing a gas filter to DIN 3386 in the gas line.

Design information (cont.)

Thermally activated safety shut-off valve

According to paragraph 4, section 5 of the FeuVo 2008 [check local fire regulations], thermally activated shut-off equipment must be installed in combustion equipment or in gas supply lines immediately upstream of the combustion equipment. This equipment must shut off the gas supply if the external temperature exceeds 100 °C. The valves must isolate the gas supply for at least 30 min up to a temperature of 650 °C. This is intended to prevent the formation of explosive gas mixtures in the event of a fire. The gas shut-off valves supplied with the Vitodens are equipped with integral, thermally activated safety shut-off valves.

Gas supply pipe

Calculate the size of the on-site gas supply pipe using the gas supply values (specification).

Sizing recommendation, gas flow switch

In supply areas with H_{IB} below 8.6 kWh/m³ and gas appliances compliant with category I_{2N}, determine a fictitious rated heat input. This fictitious rated heat input results from the rated heat input (Q_{NB}) of the gas appliance, multiplied by a factor of 1.14 (ratio H_{IB} 8.6/7.55). Use this fictitious rated heat input to select the gas flow switch and design the pipework to TRGI 2018 [or local regulations].

Vitodens rated heating output	Gas flow switch For natural gas
kW	
11 to 19	GS 4
25	GS 6
32	GS 6

The sizing recommendation for the gas flow switch does not negate the requirement for sizing the pipework correctly.

Minimum clearances

Clearance for maintenance work and operation of ON/OFF switch:

- In front of the boiler 700 mm
- To the left or right of the boiler
 - Vitodens 200-W and 222-W: No clearance required
 - Vitodens 222-F and 242-F: Min. 100 mm for operating the ON/OFF switch

Installation of the Vitodens 200-W

Accessories required in addition to installation with the pre-plumbing jig, valves/fittings or mounting frame:
Installation without DHW cylinder: Caps for cylinder flow and return

Installation with DHW cylinder: Connection set for DHW cylinder

Design information (cont.)

Pre-plumbing jig for surface mounting

With fixings, valves/fittings and gas shut-off valve R ¾ with integral, thermally activated safety shut-off valve.

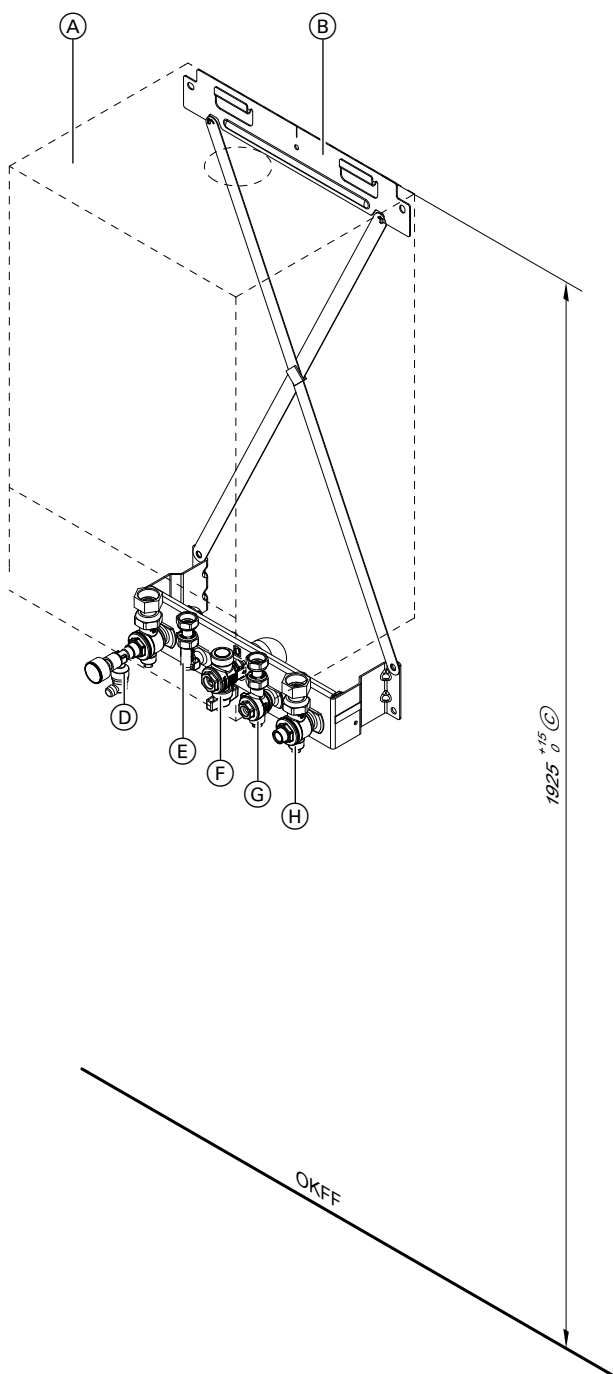

Illustration shows a gas condensing combi boiler

- | | | | |
|---|---|------|---|
| Ⓐ | Vitodens | Ⓔ | Cold water R ½ |
| Ⓑ | Pre-plumbing jig | Ⓕ | Gas connection R ¾ |
| Ⓒ | Compulsory in conjunction with DHW cylinders below the boiler; otherwise recommended. | Ⓖ | DHW R ½ |
| Ⓓ | Heating flow R ¾ with pressure gauge and air vent valve | Ⓗ | Heating return R ¾ with boiler drain & fill valve |
| | | OKFF | Top edge, finished floor |

Design information (cont.)

Valves/fittings for surface mounting

With valves/fittings and gas shut-off valve R $\frac{3}{4}$ with integral, thermally activated safety shut-off valve.

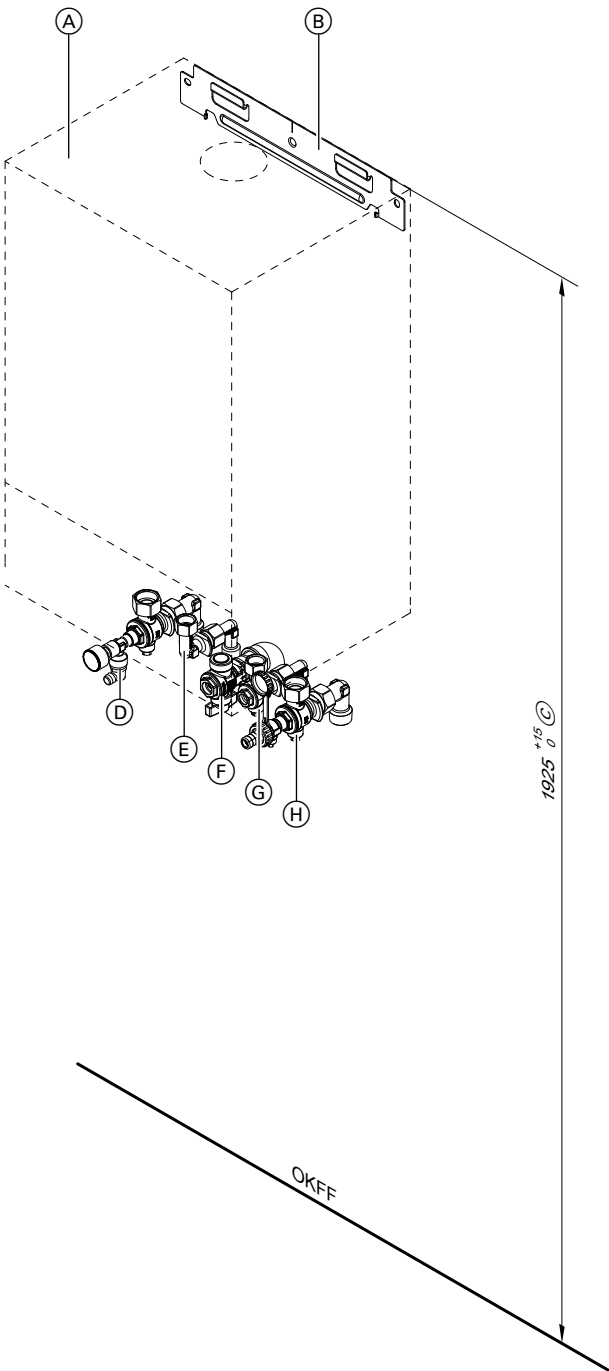

Illustration shows a gas condensing combi boiler

- | | | | |
|-----|---|------|---|
| (A) | Vitodens | (E) | Cold water R $\frac{1}{2}$ |
| (B) | Pre-plumbing jig | (F) | Gas connection R $\frac{3}{4}$ |
| (C) | Compulsory in conjunction with DHW cylinders below the boiler; otherwise recommended. | (G) | DHW R $\frac{1}{2}$ |
| (D) | Heating flow R $\frac{3}{4}$ with pressure gauge and air vent valve | (H) | Heating return R $\frac{3}{4}$ with boiler drain & fill valve |
| | | OKFF | Top edge, finished floor |

Design information (cont.)

Valves/fittings for flush mounting

With valves/fittings, gas shut-off valve R ¾ with integral, thermally activated safety shut-off valve and mounting plate.

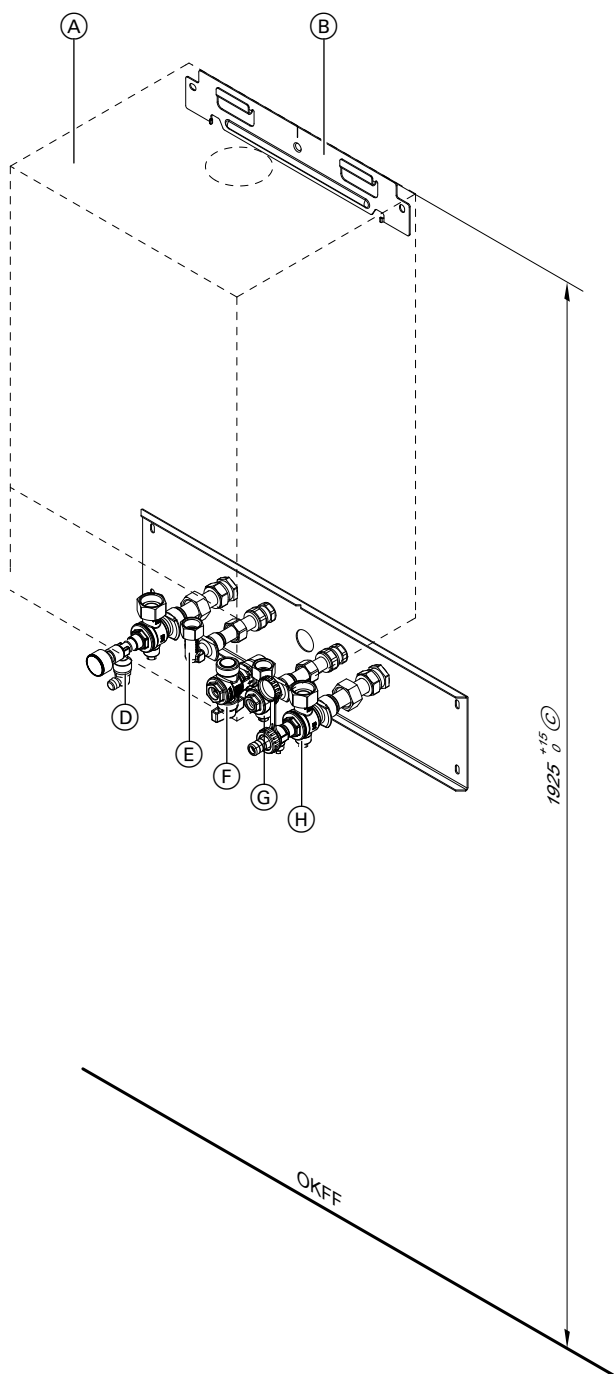

Illustration shows a gas condensing combi boiler

- | | | | |
|-----|---|------|---|
| (A) | Vitodens | (E) | Cold water R ½ |
| (B) | Pre-plumbing jig | (F) | Gas connection R ¾ |
| (C) | Compulsory in conjunction with DHW cylinders below the boiler; otherwise recommended. | (G) | DHW R ½ |
| (D) | Heating flow R ¾ with pressure gauge and air vent valve | (H) | Heating return R ¾ with boiler drain & fill valve |
| | | OKFF | Top edge, finished floor |

Design information (cont.)

Mounting frame for surface mounting

With fixings, valves/fittings and gas shut-off valve R ¾ with integral, thermally activated safety shut-off valve.

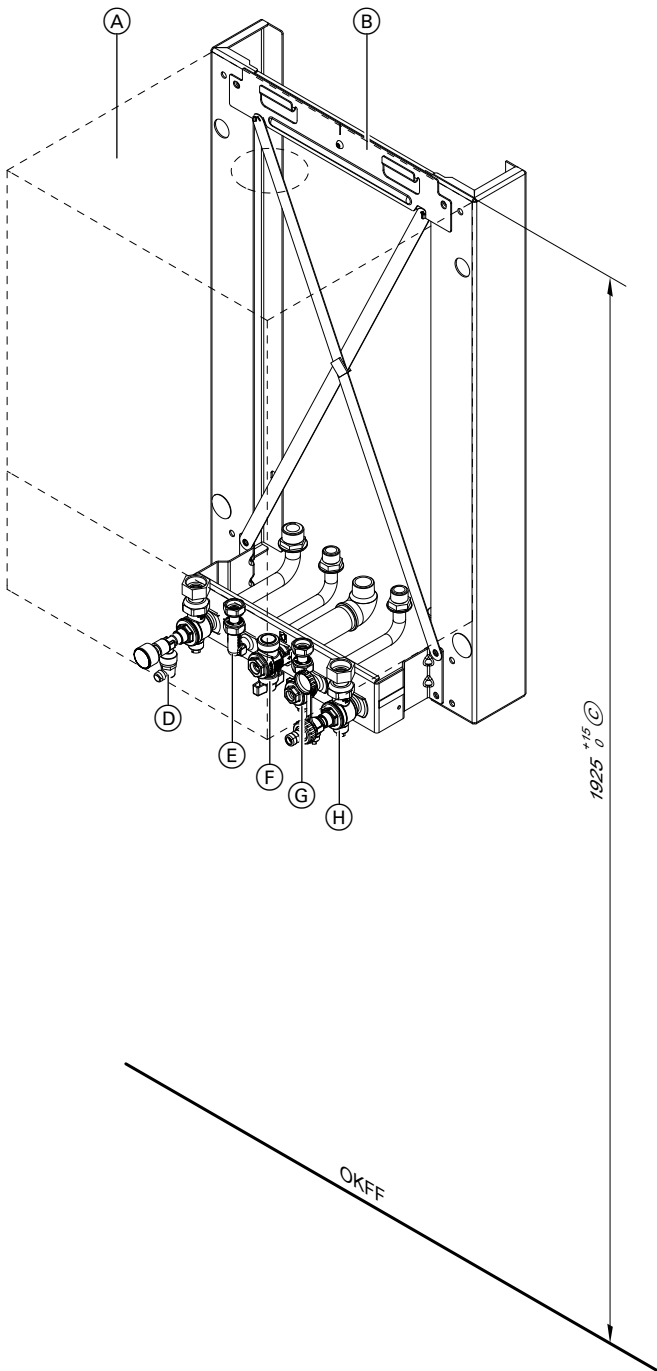

Illustration shows a gas condensing combi boiler

- | | | | |
|-----|---|------|---|
| (A) | Vitodens | (E) | Cold water R ½ |
| (B) | Mounting frame | (F) | Gas connection R ¾ |
| (C) | Compulsory in conjunction with DHW cylinders below the boiler; otherwise recommended. | (G) | DHW R ½ |
| (D) | Heating flow R ¾ with pressure gauge and air vent valve | (H) | Heating return R ¾ with boiler drain & fill valve |
| | | OKFF | Top edge, finished floor |

Installation with sub-mounting kit with mixer – surface mounting

Complete assembly for heat distribution via one heating circuit with mixer and one heating circuit without mixer, for installation below the Vitodens 200-W

Sub-mounting kit with:

- Plate heat exchanger for system separation of the heating circuit with mixer
- Variable speed high efficiency circulation pump
- 3-way mixer with mixer motor
- Adjustable bypass
- Mixer PCB, capable of communicating with the control unit via PlusBus
- Flow temperature sensor
- Valve for regulating the flow rates of both heating circuits

- Cover with same design as the wall mounted boiler
- Installation template

Additionally required accessories:

- Pre-plumbing jig with:
 - Fixings
 - Valves/fittings
 - Gas shut-off valve R ¼ with integral, thermally activated safety shut-off valve
- Connection set for DHW cylinders (if installed)

Sub-mounting kit **cannot** be used in conjunction with the Vitocell 100-W DHW cylinder below the boiler

For specification and accessories for the sub-mounting kit, see page 65.

Install a drain & fill valve on site in the flow of the heating circuit with mixer (HV2).

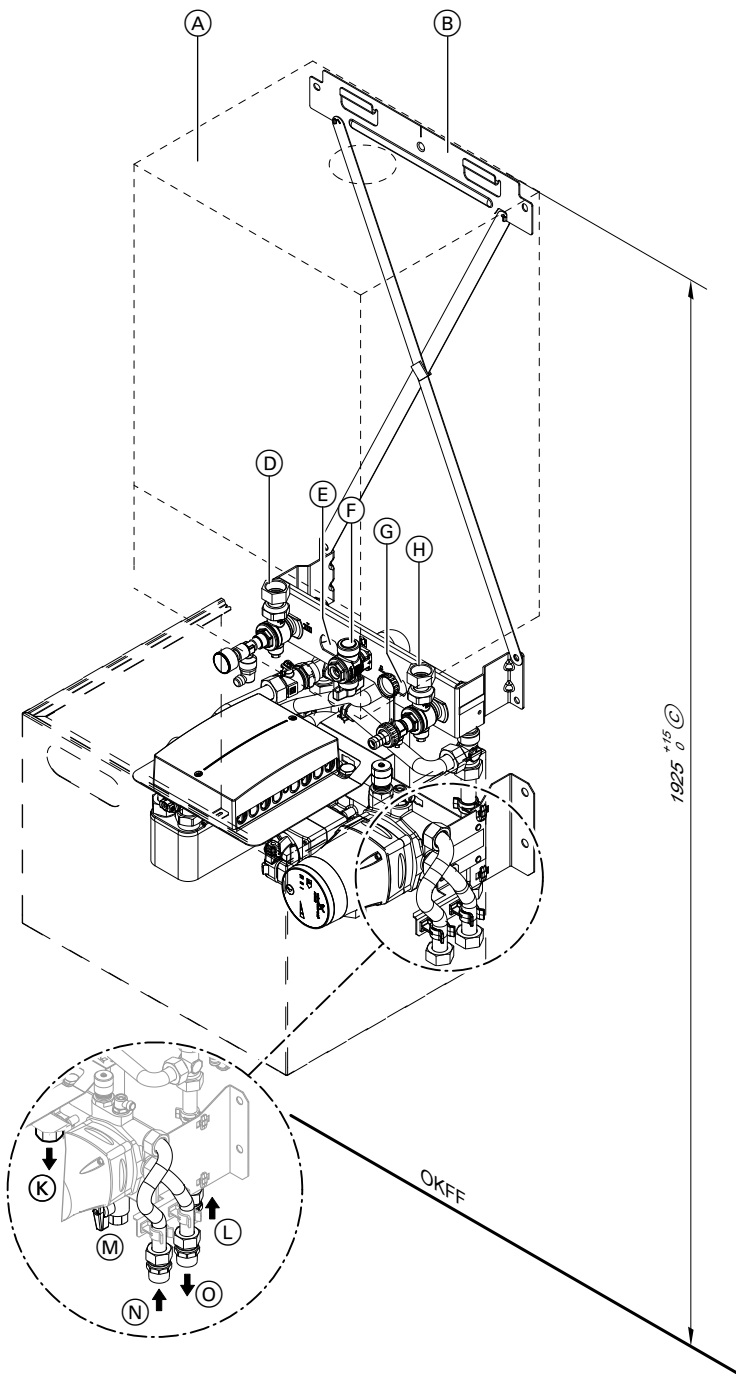

- | | | | |
|-----|---|------|---|
| (A) | Vitodens | (H) | Heating return R $\frac{3}{4}$ with boiler drain & fill valve |
| (B) | Pre-plumbing jig | (K) | Heating flow, heating circuit without mixer R $\frac{3}{4}$ |
| (C) | Recommendation | (L) | Heating return, heating circuit without mixer R $\frac{3}{4}$ |
| (D) | Heating flow R $\frac{3}{4}$ with pressure gauge and air vent valve | (M) | Gas connection R $\frac{3}{4}$ |
| (E) | Cylinder flow G $\frac{3}{4}$ | (N) | Heating return, heating circuit with mixer R $\frac{3}{4}$ |
| (F) | Gas connection G $\frac{3}{4}$ | (O) | Heating flow, heating circuit with mixer R $\frac{3}{4}$ |
| (G) | Cylinder return G $\frac{3}{4}$ | OKFF | Top edge, finished floor |

Plumbing wall installation with a plumbing wall mounting frame

Suitable for wall mounting, plumbing wall installation anywhere in the room or in front of lightweight walls.

A pre-plumbing jig (part no. ZK04307) must be ordered separately in addition to the plumbing wall mounting frame.

5853906

Design information (cont.)

8

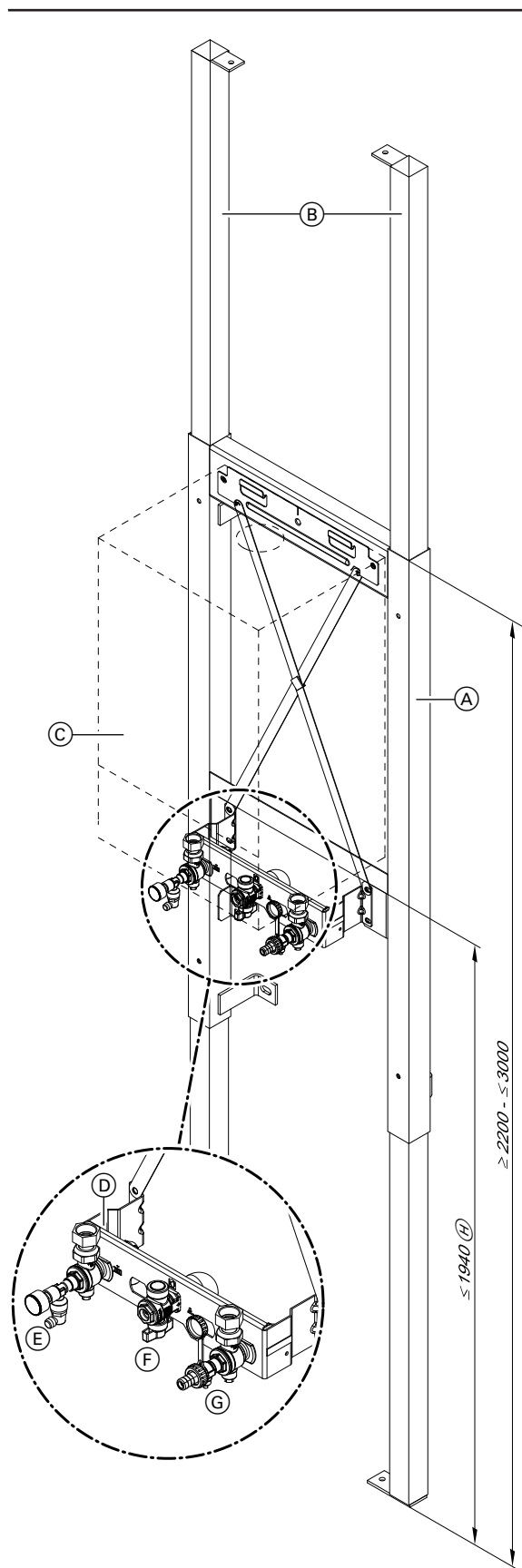

- (A) Plumbing wall mounting frame
- (B) Extension for ceiling installation
- (C) Vitodens
- (D) Pre-plumbing jig
- (E) Heating flow R $\frac{3}{4}$ with pressure gauge and air vent valve
- (F) Gas connection R $\frac{3}{4}$
- (G) Heating return R $\frac{3}{4}$ with boiler drain & fill valve
- (H) In conjunction with DHW cylinder below the boiler, min. 1933 mm

Illustration shows a gas condensing system boiler

Replacing third party boilers with the Vitodens 200-W

Using an adaptor, the Vitodens hydraulic connections are compatible with Ceramini-Z-SR, Cerastar-ZR/-ZWR and Thermoblock-VC110E-/VC112E/-VC/-VCW boilers.

For modernisation projects, adaptors are available as accessories (see pricelist). These comprise connection components for the heating water and DHW sides and fixings for replacing the third party appliances listed below with a Vitodens. A pre-plumbing jig for surface mounting or valves/fittings for surface mounting must be ordered separately in addition to the Vitodens 200-W.

The installation work involved is no greater than replacement with a same-brand appliance.

Where a wall mounted gas boiler is replaced by a Vitodens 200-W gas condensing system boiler, the flue must also be replaced with a system that is suitable for "condensing operation" (see pricelist "Flue systems for the Vitodens").

Adapt the flue connections on site.

Note

For modernisation projects, the State Building Regulations [Germany] require the on-site installation of a gas shut-off valve with thermally activated shut-off facility.

Replacing a Ceramini-Z-SR with a Vitodens 200-W, 11 and 19 kW

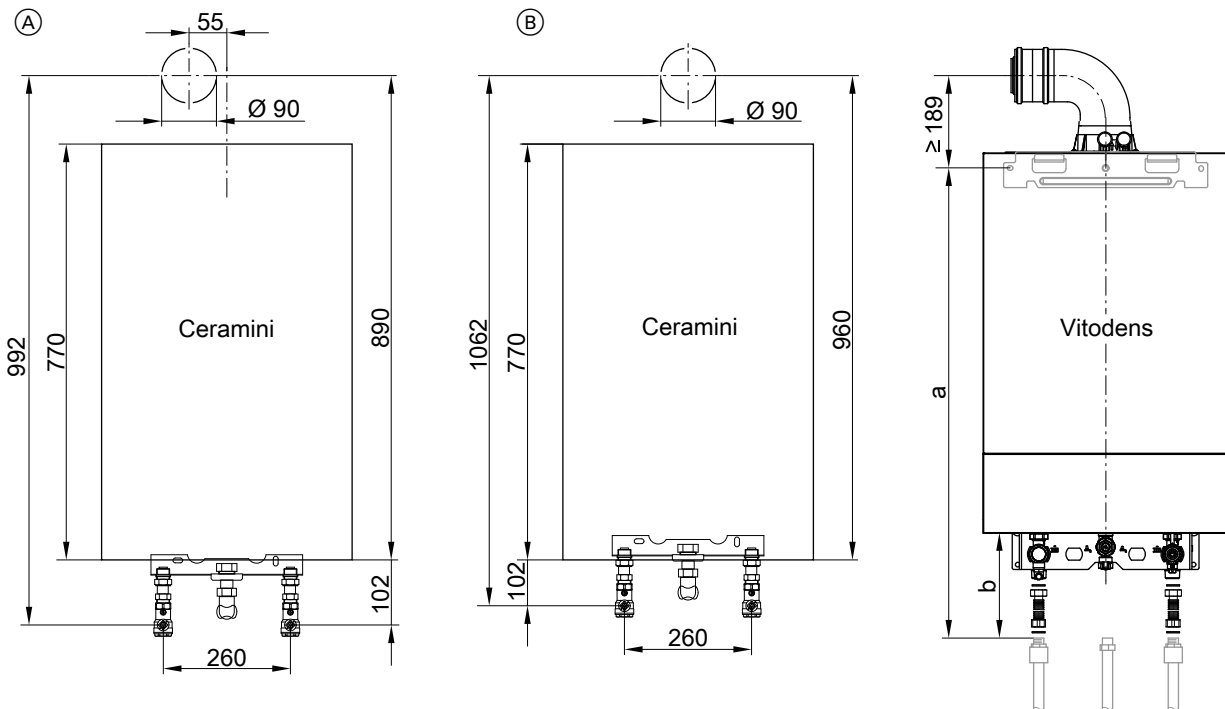

- Ⓐ Open flue operation
- Ⓑ Room sealed operation

Dim.	Flush mounting	Surface mounting
a mm	790 ^{+25/-0}	802 ^{+50/-0}

Note

Height of flue gas connection in combination with balanced flue bend 60/100. If using a balanced flue inspection bend 60/100, the height is reduced by 10 mm.

Design information (cont.)

Replacing a Cerastar-ZR/-ZWR with a Vitodens 200-W, 25 and 32 kW

8

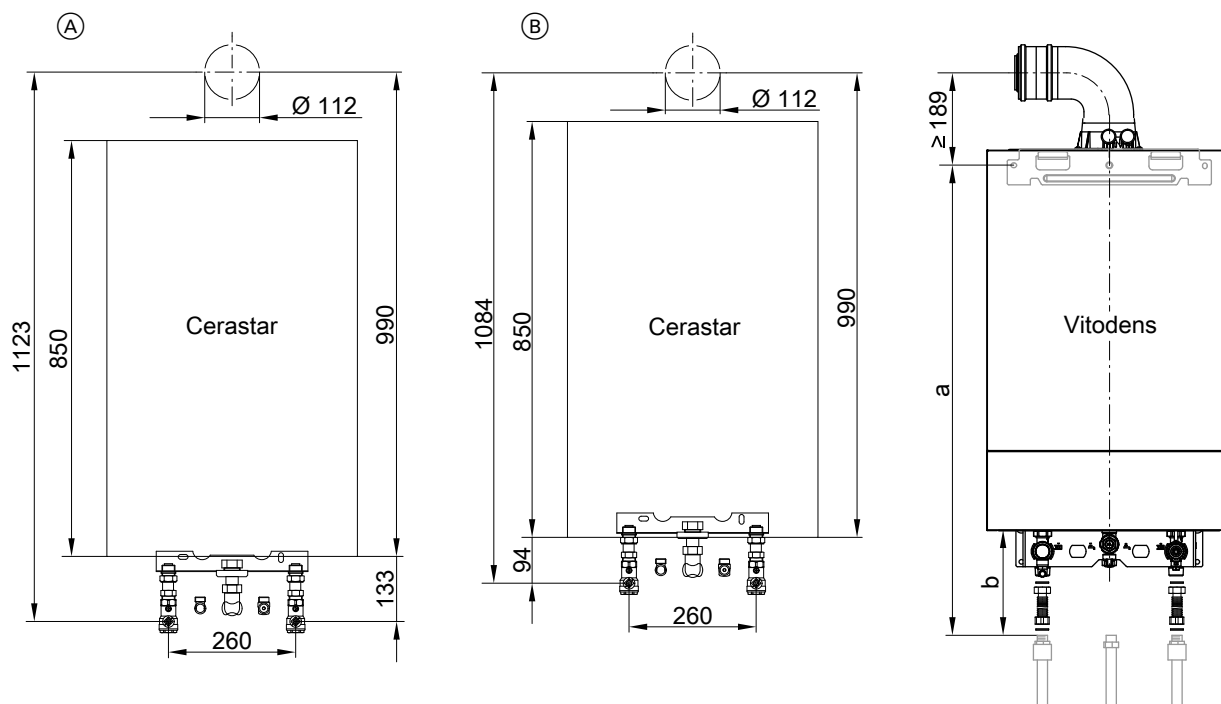

- (A) Open flue operation
- (B) Room sealed operation

Dim.		Flush mounting	Surface mounting
a	mm	790 ^{+25/-0}	802 ^{+50/-0}

Note

Height of flue gas connection in combination with balanced flue bend 60/100. If using a balanced flue inspection bend 60/100, the height is reduced by 10 mm.

Design information (cont.)

Replacing a Thermoblock-VC110E/-VC112E with a Vitodens 200-W, 11 and 19 kW

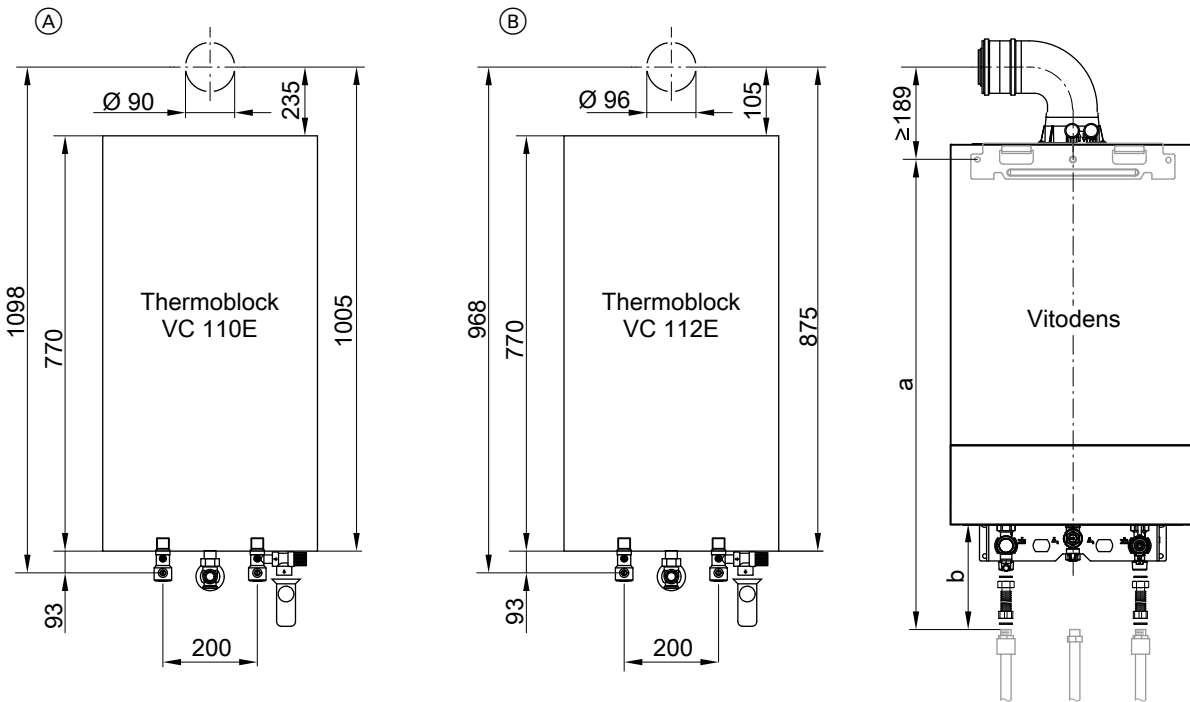

- (A) Open flue operation
- (B) Room sealed operation

Dim.	Flush mounting	Surface mounting
a mm	786 ^{+25/-0}	802 ^{+50/-0}

Note

Height of flue gas connection in combination with balanced flue bend 60/100. If using a balanced flue inspection bend 60/100, the height is reduced by 10 mm.

Design information (cont.)

Replacing a Thermoblock-VC/-VCW with a Vitodens 200-W, 25 and 32 kW

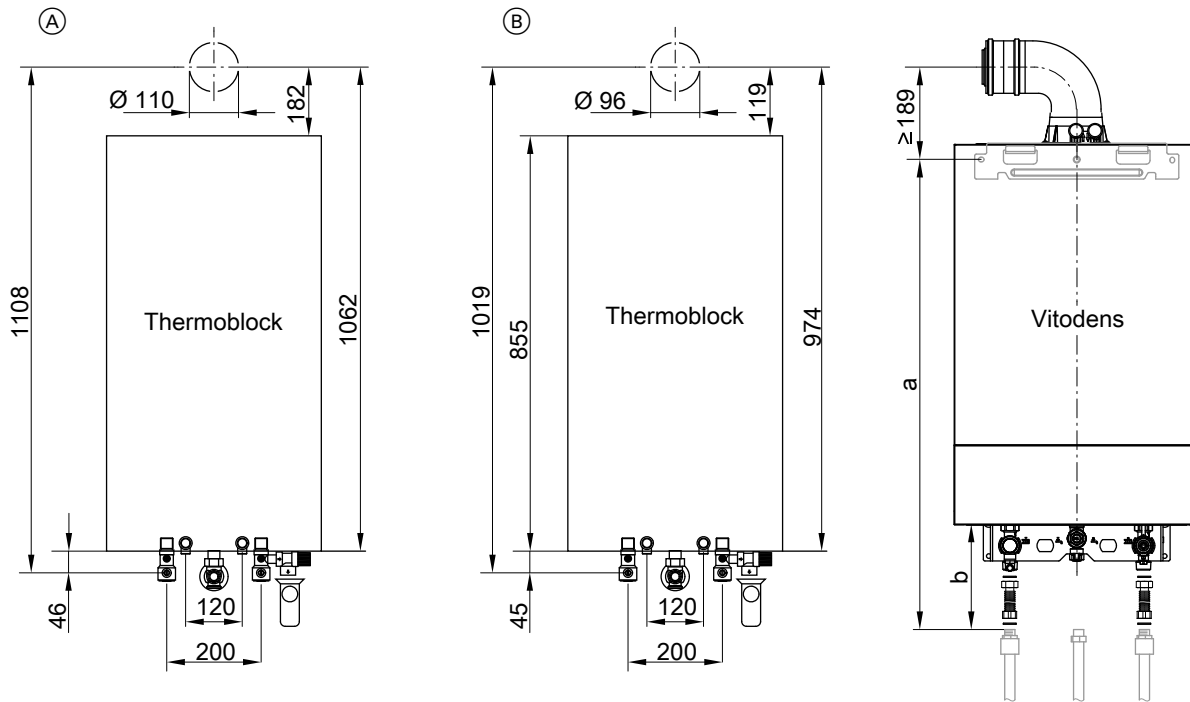

- (A) Open flue operation
- (B) Room sealed operation

Dim.	Flush mounting	Surface mounting
a mm	786 ^{+25/-0}	802 ^{+50/-0}

Note

Height of flue gas connection in combination with balanced flue bend 60/100. If using a balanced flue inspection bend 60/100, the height is reduced by 10 mm.

Design information (cont.)

Pre-installation of the Vitodens 222-W

Pre-plumbing jig for surface mounting

Pre-plumbing jig, comprising:

- Fixings
- Valves/fittings

- Gas shut-off valve
- Safety valve on the DHW side

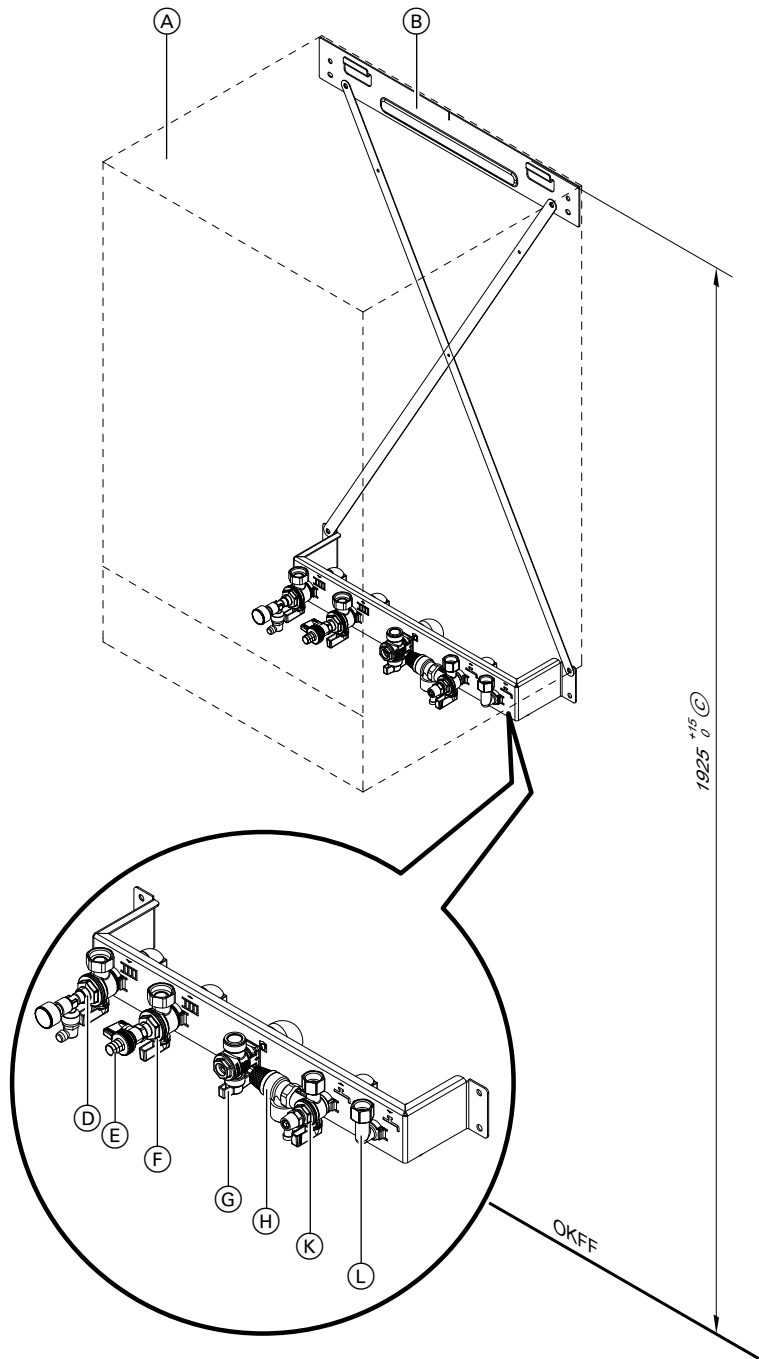

- Ⓐ Vitodens
- Ⓑ Pre-plumbing jig
- Ⓒ Recommended installation height
- Ⓓ Heating flow R $\frac{3}{4}$
- Ⓔ Filling/draining

- Ⓕ Heating return R $\frac{3}{4}$
- Ⓖ Gas connection R $\frac{3}{4}$
- Ⓗ Safety valve on the DHW side
- Ⓚ Cold water R $\frac{1}{2}$
- Ⓛ DHW R $\frac{1}{2}$

Design information (cont.)

Mounting frame for surface mounting

Mounting frame, comprising:

- Fixings
- Valves/fittings

- Gas shut-off valve
- Safety valve on the DHW side

Wall clearance 90 mm

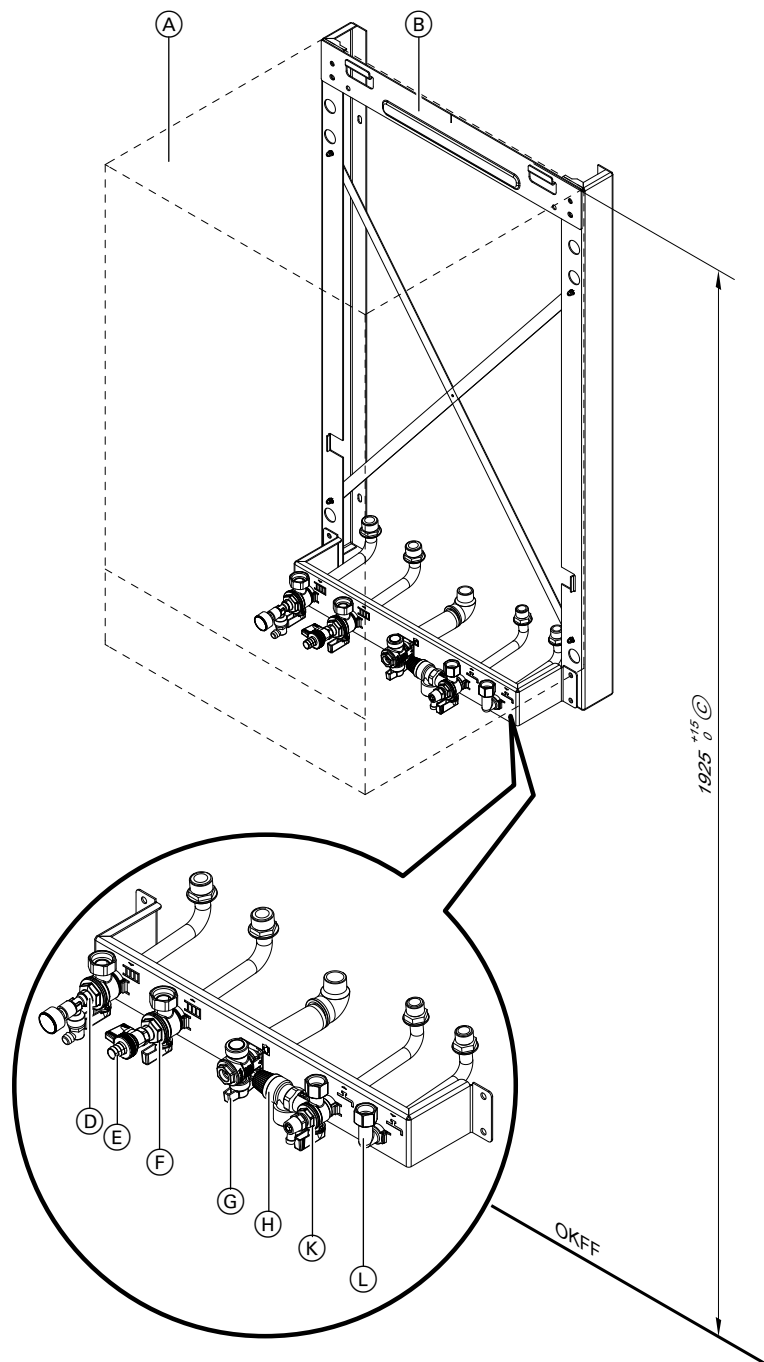

- (A) Vitodens
- (B) Mounting frame
- (C) Recommended installation height
- (D) Heating flow R $\frac{3}{4}$
- (E) Filling/draining

- (F) Heating return R $\frac{3}{4}$
- (G) Gas connection R $\frac{3}{4}$
- (H) Safety valve on the DHW side
- (K) Cold water R $\frac{1}{2}$
- (L) DHW R $\frac{1}{2}$

Design information (cont.)

Valves/fittings for surface mounting

With valves/fittings and gas shut-off valve R $\frac{3}{4}$ with integral, thermally activated safety shut-off valve.

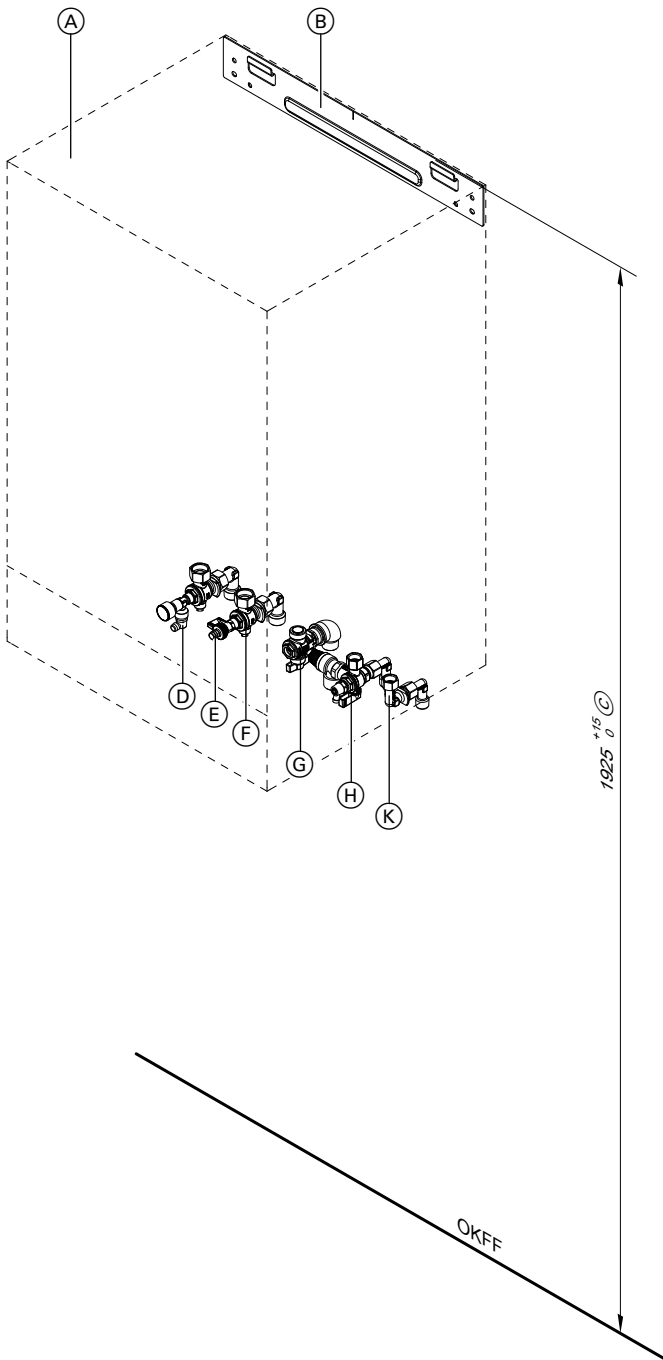

- (A) Vitodens
- (B) Wall mounting bracket (Vitodens standard delivery)
- (C) Recommended installation height
- (D) Heating flow R $\frac{3}{4}$
- (E) Filling/draining

- (F) Heating return R $\frac{3}{4}$
- (G) Gas connection R $\frac{3}{4}$
- (H) Safety valve on the DHW side
- (K) Cold water R $\frac{1}{2}$
- (L) DHW R $\frac{1}{2}$
- OKFF Top edge, finished floor

Design information (cont.)

Valves/fittings for flush mounting

With valves/fittings, gas shut-off valve R 3/4 with integral, thermally activated safety shut-off valve and mounting plate.

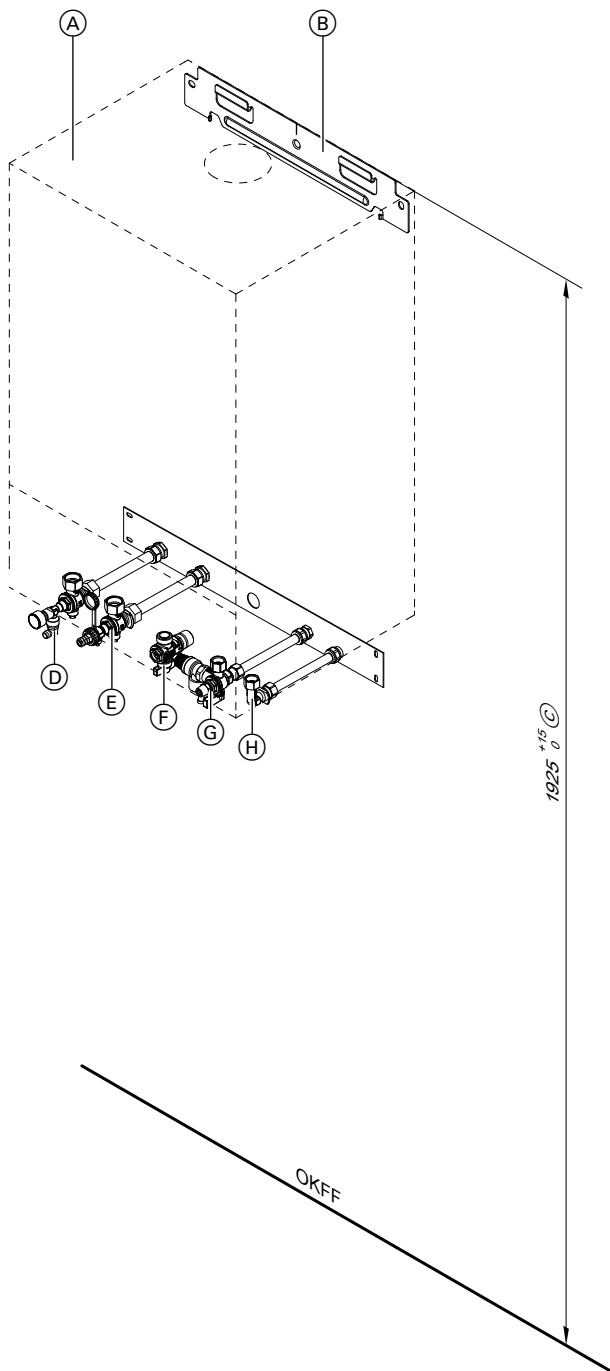

- | | | | |
|-----|--|------|------------------------------|
| (A) | Vitodens | (F) | Heating return R 3/4 |
| (B) | Wall mounting bracket (Vitodens standard delivery) | (G) | Gas connection R 3/4 |
| (C) | Recommended installation height | (H) | Safety valve on the DHW side |
| (D) | Heating flow R 3/4 | (K) | Cold water R 1/2 |
| (E) | Filling/draining | (L) | DHW R 1/2 |
| | | OKFF | Top edge, finished floor |

Installation with sub-mounting kit with mixer – surface mounting

Complete assembly for heat distribution via one heating circuit with mixer and one heating circuit without mixer, for installation below the Vitodens 222-W.

Sub-mounting kit with:

- Plate heat exchanger for system separation of the heating circuit with mixer
- Variable speed high efficiency circulation pump
- 3-way mixer with mixer motor



Design information (cont.)

- Adjustable bypass
- Mixer PCB, capable of communicating with the control unit via PlusBus
- Flow temperature sensor
- Valve for regulating the flow rates of both heating circuits
- Cover with same design as the wall mounted boiler
- Installation template

Additionally required accessories:

- Pre-plumbing jig with:
 - Fixings
 - Valves/fittings
 - Gas shut-off valve R $\frac{3}{4}$ with integral, thermally activated safety shut-off valve

For specification and accessories for the sub-mounting kit, see page 72.
Install a drain & fill valve on site in the flow of the heating circuit with mixer (HV2).

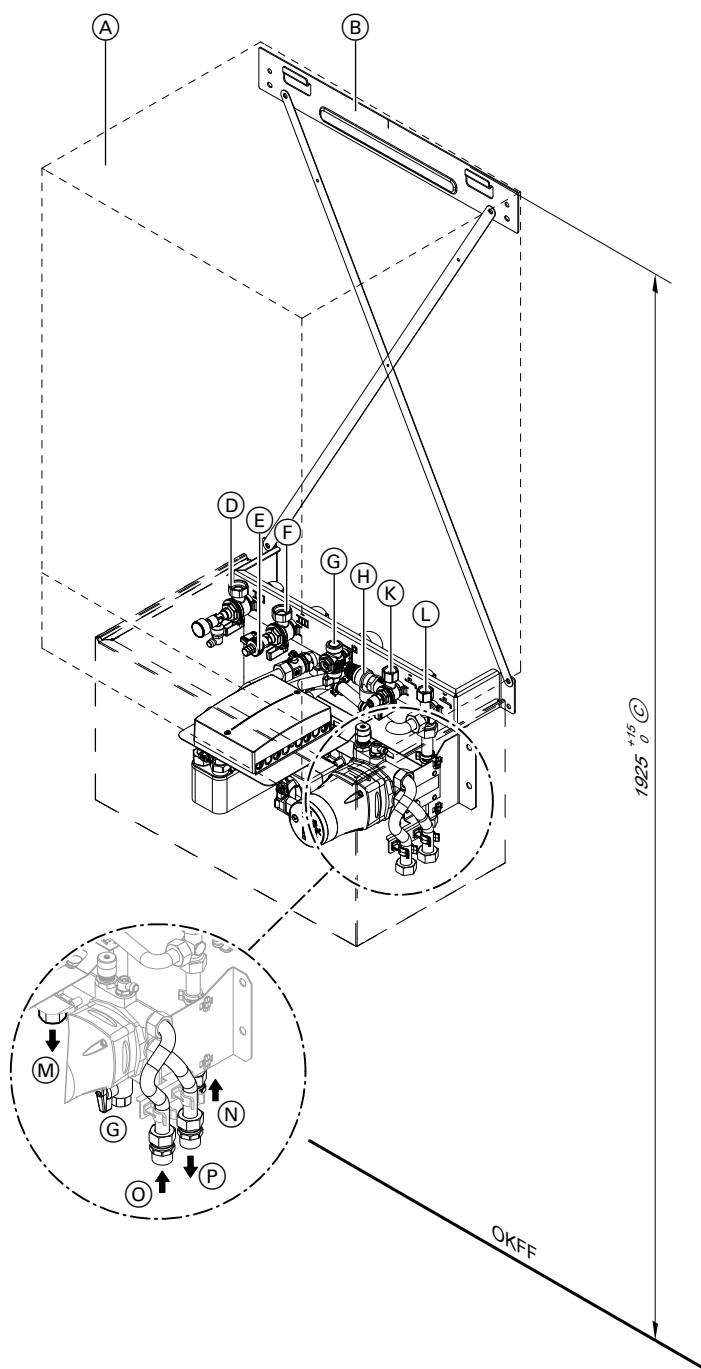

- (A) Vitodens
- (B) Pre-plumbing jig
- (C) Recommended installation height
- (D) Heating flow R $\frac{3}{4}$ with pressure gauge and air vent valve
- (E) Filling/draining
- (F) Heating return R $\frac{3}{4}$ with boiler drain & fill valve
- (G) Gas connection G $\frac{3}{4}$

- (H) Safety valve on the DHW side
- (K) Cold water R $\frac{1}{2}$
- (L) DHW R $\frac{1}{2}$
- (M) Heating flow, heating circuit without mixer R $\frac{3}{4}$
- (N) Heating return, heating circuit without mixer R $\frac{3}{4}$
- (O) Heating return, heating circuit with mixer R $\frac{3}{4}$
- (P) Heating flow, heating circuit with mixer R $\frac{3}{4}$
- OKFF Top edge, finished floor

Installation of the Vitodens 222-F

Connection set for surface mounting; upward connection
 For connecting the on-site gas, heating water and DHW lines from above.

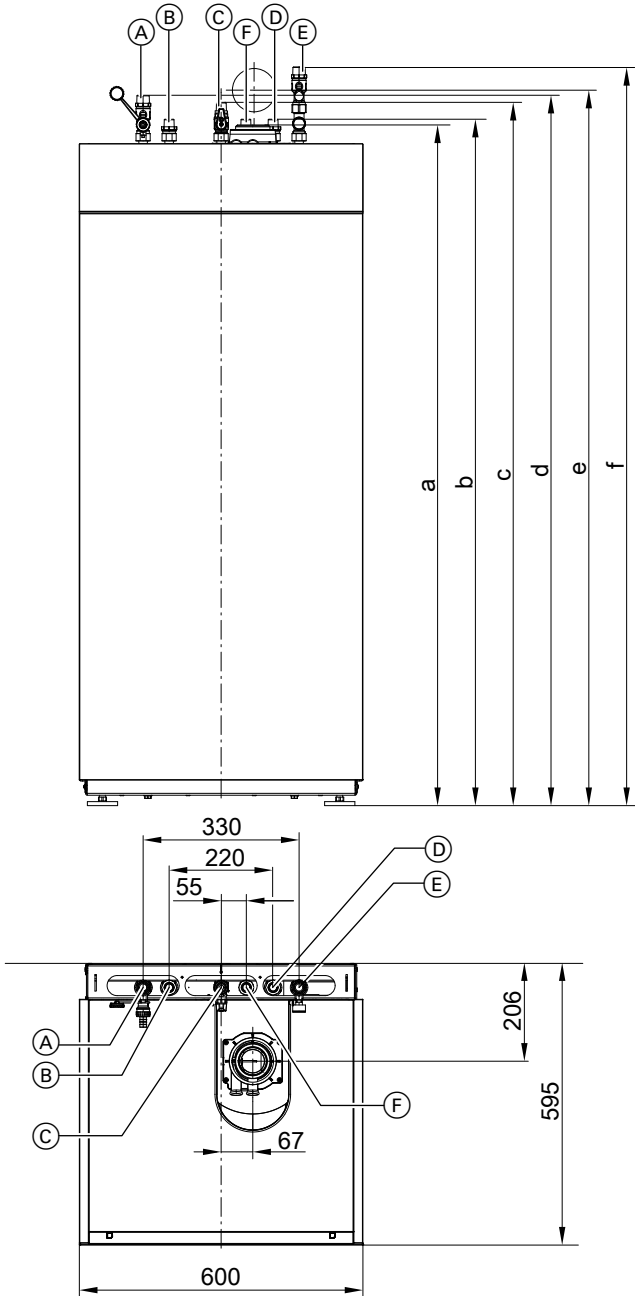

- (A) Heating flow R $\frac{3}{4}$
- (B) DHW R $\frac{1}{2}$
- (C) Gas connection R $\frac{1}{2}$
- (D) Cold water R $\frac{1}{2}$
- (E) Heating return R $\frac{3}{4}$
- (F) DHW circulation R $\frac{1}{2}$ (separate accessories)

Vitodens 222-F	a	b	c	d	e	f
	mm	mm	mm	mm	mm	mm
Type B2TE	1440	1452	1488	1503	1520	1563
Type B2SE	1640	1652	1688	1703	1720	1763

Note
 All height dimensions have a tolerance of +15 mm on account of the adjustable feet.

- Connection set, comprising:
- Connection pipes
 - Shut-off valves for heating water flow and return, with boiler drain & fill valve

5853906

Design information (cont.)

- 2 connectors for DHW
- Gas shut-off valve with thermally activated safety shut-off valve

Connection set for surface mounting; connection to the left or right

For connecting the on-site gas, heating water and DHW lines from the left or right.

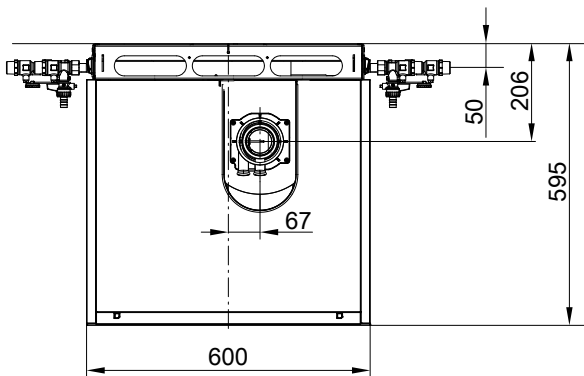
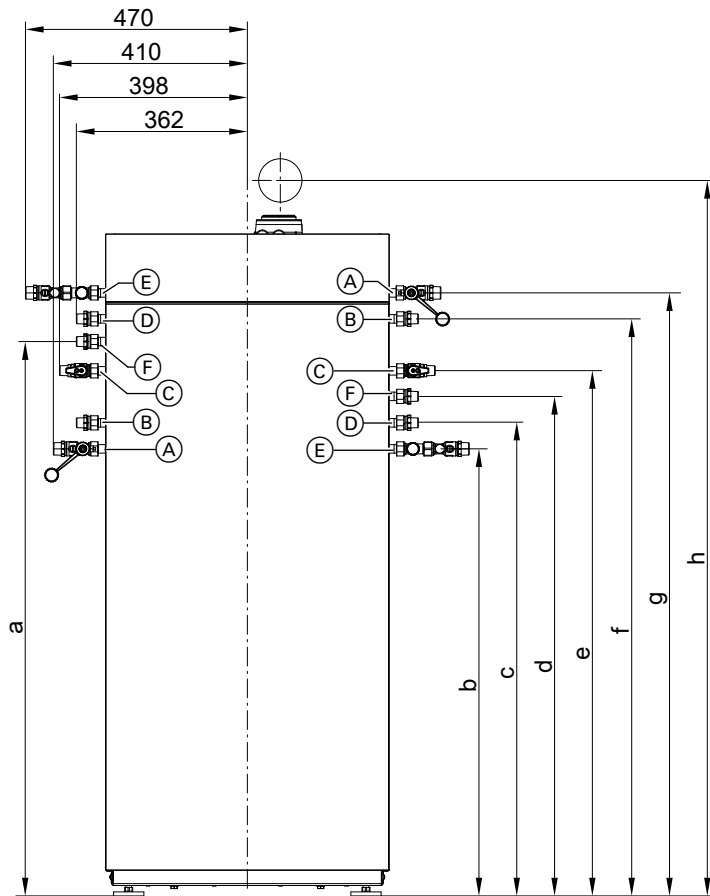

- | | |
|------------------------------------|--|
| (A) Heating flow R $\frac{3}{4}$ | (D) Cold water R $\frac{1}{2}$ |
| (B) DHW R $\frac{1}{2}$ | (E) Heating return R $\frac{3}{4}$ |
| (C) Gas connection R $\frac{1}{2}$ | (F) DHW circulation R $\frac{1}{2}$ (separate accessories) |

Vitodens 222-F	a mm	b mm	c mm	d mm	e mm	f mm	g mm	h mm
Type B2TE	1166	946	1001	1056	1111	1221	1276	1520
Type B2SE	1366	1146	1201	1256	1311	1421	1476	1720

Design information (cont.)

Note

All height dimensions have a tolerance of +15 mm on account of the adjustable feet.

■ 2 connectors for DHW

■ Gas shut-off valve with thermally activated safety shut-off valve

Connection set, comprising:

- Connection pipes
- Shut-off valves for heating water flow and return, with boiler drain & fill valve

Connection set for flush mounting

For connecting the on-site gas, heating water and DHW lines in the wall.

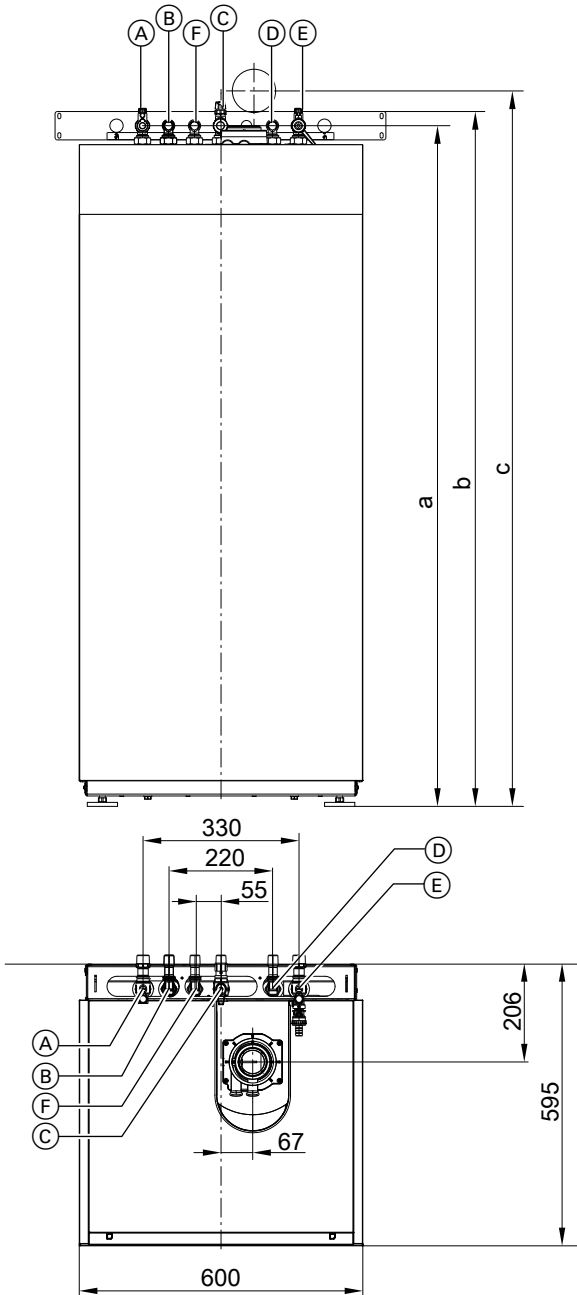

- (A) Heating flow R $\frac{3}{4}$
- (B) DHW R $\frac{1}{2}$
- (C) Gas connection R $\frac{3}{4}$

- (D) Cold water R $\frac{1}{2}$
- (E) Heating return R $\frac{3}{4}$
- (F) DHW circulation R $\frac{1}{2}$ (separate accessories)

Design information (cont.)

Vitodens 222-F	a mm	b mm	c mm
Type B2TE	1439	1469	1520
Type B2SE	1639	1669	1720

Note

All height dimensions have a tolerance of +15 mm on account of the adjustable feet.

Note

In place of the connection bend for cold water, a safety assembly (separate accessories) can be fitted.

Connection set, comprising:

- Mounting plate
- Connection pipes
- Shut-off valves for heating water flow and return, with boiler drain & fill valve
- 2 connectors for DHW
- Angle gas valve with thermally activated safety shut-off valve

Design information (cont.)

Assembly kit with mixer for surface mounting

For connecting the on-site gas, heating water and DHW lines from above.

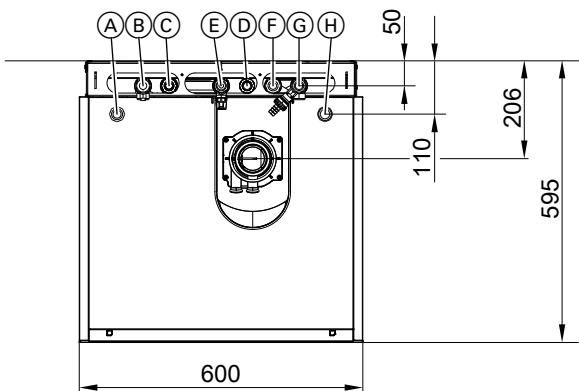
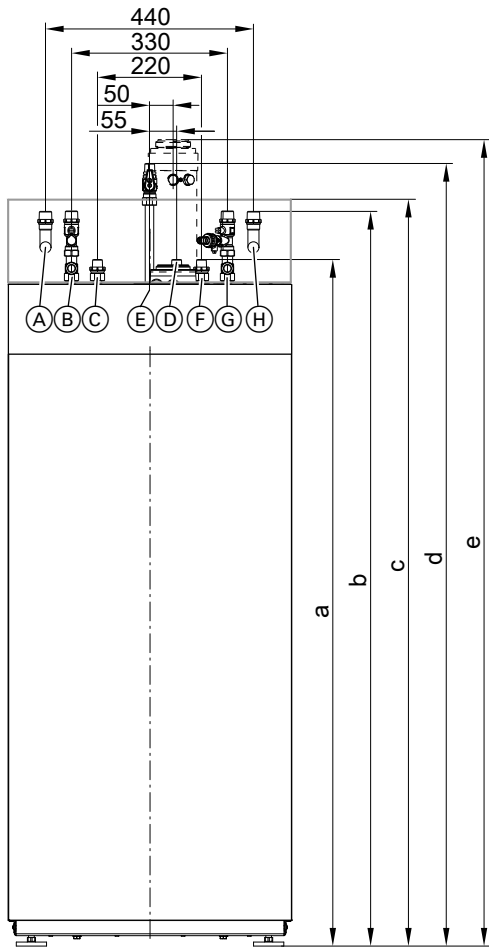

- Ⓐ Heating flow, heating circuit with mixer R $\frac{3}{4}$
- Ⓑ Heating flow, heating circuit without mixer R $\frac{3}{4}$
- Ⓒ DHW R $\frac{1}{2}$
- Ⓓ DHW circulation R $\frac{1}{2}$ (separate accessories)

- Ⓔ Gas connection R $\frac{1}{2}$
- Ⓕ Cold water R $\frac{1}{2}$
- Ⓖ Heating return, heating circuit without mixer R $\frac{3}{4}$
- Ⓗ Heating return, heating circuit with mixer R $\frac{3}{4}$

Vitodens 222-F	a	b	c	d	e
	mm	mm	mm	mm	mm
Type B2TE	1455	1557	1577	1657	1685
Type B2SE	1655	1757	1777	1957	1885

5853906

Design information (cont.)

Note

The adjustable feet give the height measurements of the connections a tolerance of + 15 mm.

Assembly kit, comprising:

- Plate heat exchanger for system separation of the heating circuit with mixer
- Variable speed high efficiency circulation pump for the heating circuit with mixer
- 3-way mixer with mixer motor
- Mixer PCB, capable of communicating with the control unit via PlusBus
- Adjustable bypass

- Flow temperature sensor
- Connection set for surface mounting with:
 - Connection pipes
 - Shut-off valves for heating water flow and return, with boiler drain & fill valve
 - 2 connectors for DHW
 - Gas shut-off valve with thermally activated safety shut-off valve
- Balanced flue extension, boiler flue connection
- Cover with same design as the boiler

Note

In combination with the assembly kit, the Vitodens 222-F has protection class IP X1.

Installation of the Vitodens 242-F

Connection set for surface mounting; upward connection

For connecting the on-site gas, heating water and DHW lines from above.

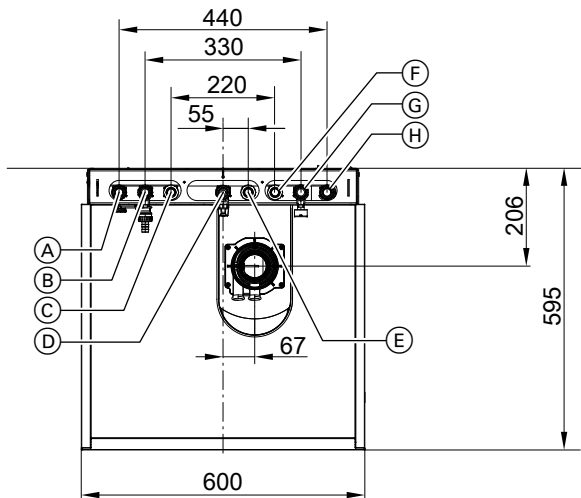
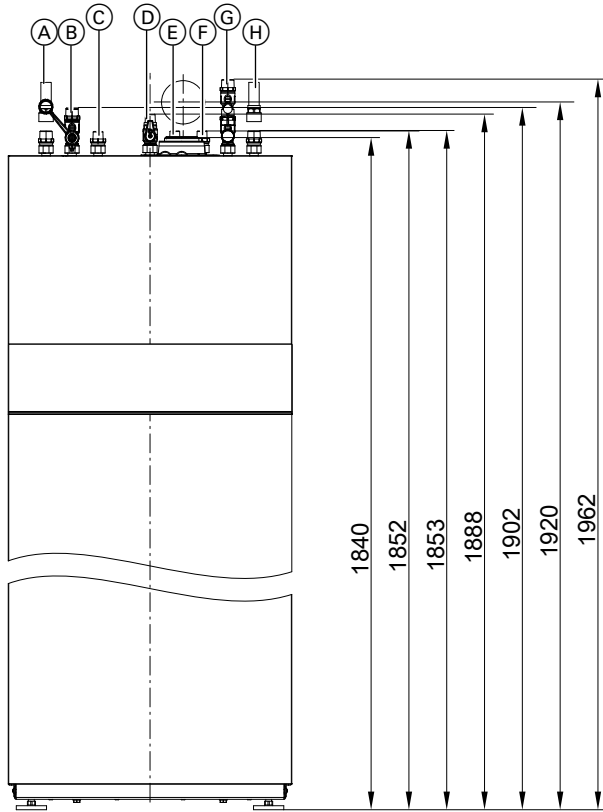

- (A) Solar return R $\frac{3}{4}$ "/Ø 22 mm
- (B) Heating flow R $\frac{3}{4}$ "
- (C) DHW R $\frac{1}{2}$ "
- (D) Gas connection R $\frac{1}{2}$ "
- (E) DHW circulation R $\frac{1}{2}$ " (separate accessories)
- (F) Cold water R $\frac{1}{2}$ "
- (G) Heating return R $\frac{3}{4}$ "
- (H) Solar flow R $\frac{3}{4}$ "/Ø 22 mm

Connection set, comprising:

- Connection pipes
- Shut-off valves for heating water flow and return, with boiler drain & fill valve
- 2 connectors for DHW
- 2 connectors each for solar flow and return (R $\frac{3}{4}$ "/Ø 22 mm)
- Gas shut-off valve with thermally activated safety shut-off valve

Note

All height dimensions have a tolerance of +15 mm on account of the adjustable feet.

5853906

Design information (cont.)

Connection set for surface mounting; connection to the left or right

For connecting the on-site gas, heating water and DHW lines from the left or right.

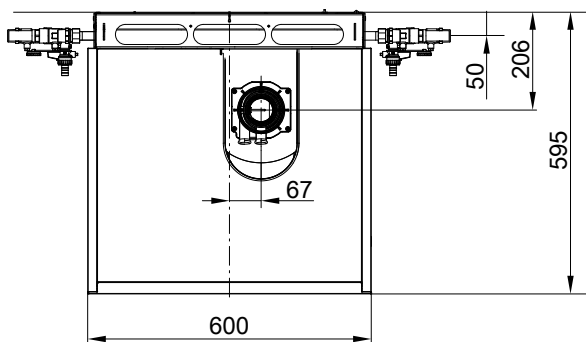
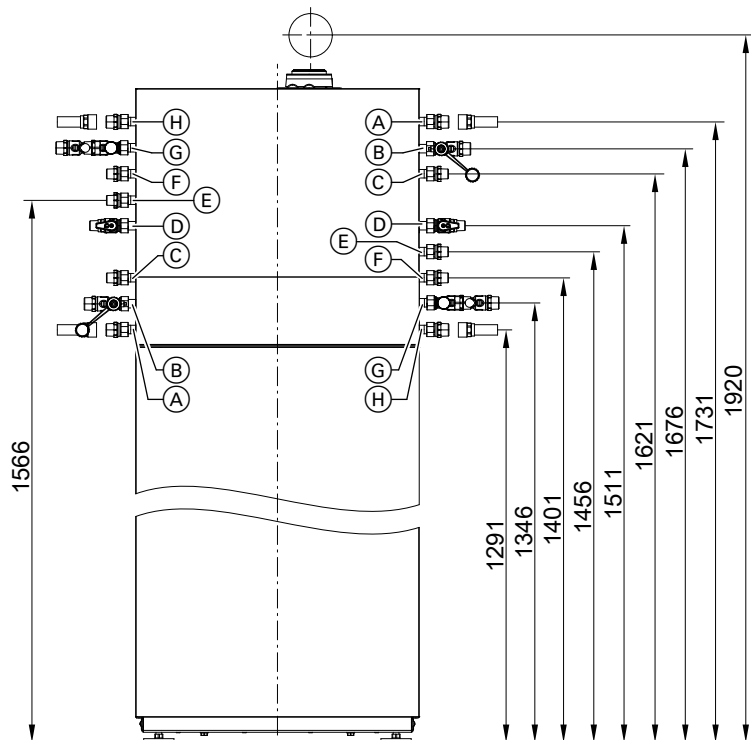

- (A) Solar return R $\frac{3}{4}$ /Ø 22 mm
- (B) Heating flow R $\frac{3}{4}$
- (C) DHW R $\frac{1}{2}$
- (D) Gas connection R $\frac{1}{2}$
- (E) DHW circulation R $\frac{1}{2}$ (separate accessories)
- (F) Cold water R $\frac{1}{2}$
- (G) Heating return R $\frac{3}{4}$
- (H) Solar flow R $\frac{3}{4}$ /Ø 22 mm

Connection set, comprising:

- Connection pipes
- Shut-off valves for heating water flow and return, with boiler drain & fill valve
- 2 connectors for DHW
- 2 connectors each for solar flow and return (R $\frac{3}{4}$ /Ø 22 mm)
- Gas shut-off valve with thermally activated safety shut-off valve

Note

All height dimensions have a tolerance of +15 mm on account of the adjustable feet.

Design information (cont.)

Connection set for flush mounting

For connecting the on-site gas, heating water and DHW lines in the wall.

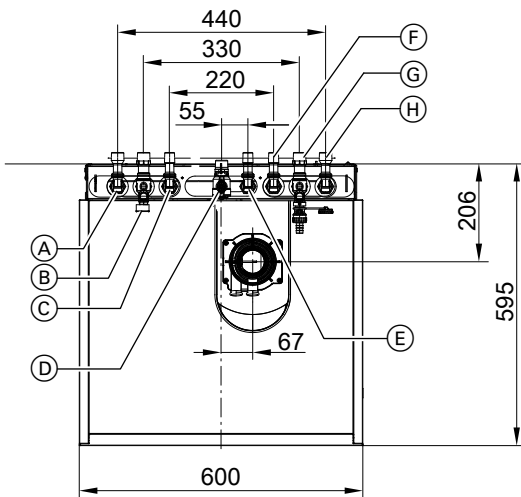
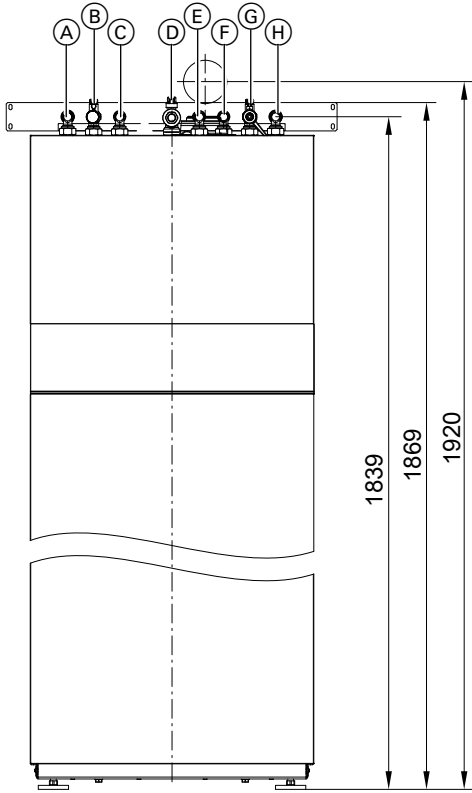

- (A) Solar return R $\frac{3}{4}$ /Ø 22 mm
- (B) Heating flow R $\frac{3}{4}$
- (C) DHW R $\frac{1}{2}$
- (D) Gas connection R $\frac{3}{4}$
- (E) DHW circulation R $\frac{1}{2}$ (separate accessories)
- (F) Cold water R $\frac{1}{2}$
- (G) Heating return R $\frac{3}{4}$
- (H) Solar flow R $\frac{3}{4}$ /Ø 22 mm

Note

All height dimensions have a tolerance of +15 mm on account of the adjustable feet.

Note

In place of the connection bend for cold water, a safety assembly (separate accessories) can be fitted.

Connection set, comprising:

- Mounting plate
- Connection pipes
- Shut-off valves for heating water flow and return, with boiler drain & fill valve
- 2 connectors for DHW
- 2 connectors each for solar flow and return (R $\frac{3}{4}$ /Ø 22 mm)
- Angle gas valve with thermally activated safety shut-off valve

Design information (cont.)

Assembly kit with mixer for surface mounting

For connecting the on-site gas, heating water and DHW lines from above.

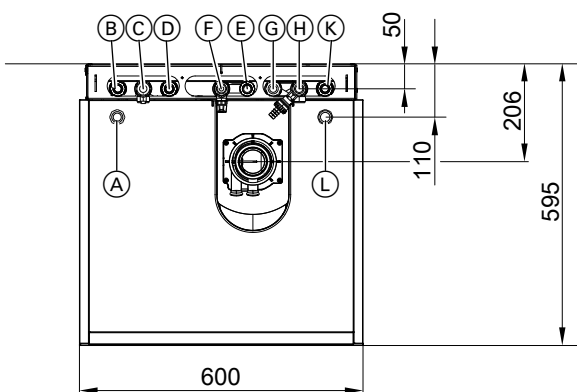
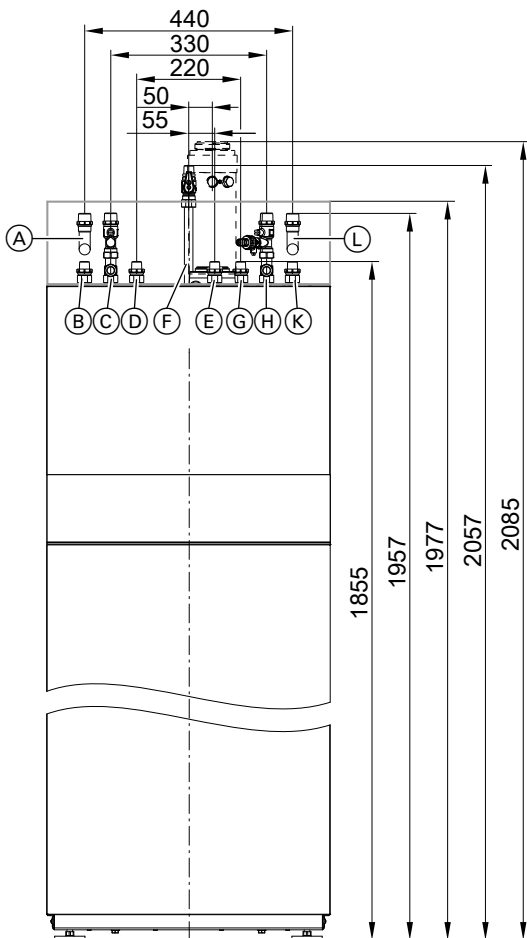

- (A) Heating flow, heating circuit with mixer R $\frac{3}{4}$
- (B) Solar return R $\frac{3}{4}$ /Ø 22 mm
- (C) Heating flow, heating circuit without mixer R $\frac{3}{4}$
- (D) DHW R $\frac{1}{2}$
- (E) DHW circulation R $\frac{1}{2}$ (separate accessories)
- (F) Gas connection R $\frac{1}{2}$
- (G) Cold water R $\frac{1}{2}$
- (H) Heating return, heating circuit without mixer R $\frac{3}{4}$
- (K) Solar flow R $\frac{3}{4}$ /Ø 22 mm
- (L) Heating return, heating circuit with mixer R $\frac{3}{4}$

Note

The adjustable feet give the height measurements of the connections a tolerance of + 15 mm.

Assembly kit, comprising:

- Plate heat exchanger for system separation of the heating circuit with mixer
- Variable speed high efficiency circulation pump for the heating circuit with mixer
- 3-way mixer with mixer motor



Design information (cont.)

- Mixer PCB, capable of communicating with the control unit via PlusBus
- Adjustable bypass
- Flow temperature sensor
- Connection set for surface mounting with:
 - Connection pipes
 - Shut-off valves for heating water flow and return, with boiler drain & fill valve
 - 2 connectors for DHW
 - 2 connectors each for solar flow and return (R ¾/Ø 22 mm)
 - Gas shut-off valve with thermally activated safety shut-off valve
- Balanced flue extension, boiler flue connection
- Cover with same design as the boiler

Note

In combination with the assembly kit, the Vitodens 242-F has protection class IP X1.

8.2 Decision making aids for DHW heating

To provide the perfect solution for every situation, the Vitodens is available in the following versions:

- Vitodens 200-W
 - As a gas system boiler in combination with a separate DHW cylinder
 - As a gas condensing combi boiler with integral, direct DHW heating
- Vitodens 222-W
 - With integral DHW loading cylinder
- Vitodens 222-F and 242-F
 - With integral DHW loading cylinder

Various factors should be taken into consideration when designing heating systems and deciding between a gas system boiler with a separate DHW cylinder or a gas system boiler with an integral DHW loading cylinder:

- DHW demand, convenience
- Use of the various connected draw-off points
- Distance of the draw-off points from the boiler
- System modernisation
- Space available
- Water quality

Information on water quality

During DHW heating, settling of lime on the surfaces of the plate heat exchanger cannot be completely prevented. The tendency towards limescale build-up depends on various conditions, predominantly on the substances contained in the water, the amount of water that is heated (DHW consumption) and the DHW temperature. Although scale deposits inside the plate heat exchanger are generally minor enough not to cause any reduction in DHW output, such impairment cannot be excluded with increased water hardness. From a water hardness of 20 °dH (3.5 mol/m³) and higher, we therefore recommend the use of DHW cylinders with internal indirect coils or a water treatment system in the cold water supply when heating DHW.

Please note that regional water supply utilities frequently specify an average water hardness. Higher levels of water hardness may therefore occur from time to time. This may make the use of a water treatment facility advisable even from 17 °dH (> 3.0 mol/m³) upwards.

Selection table

		Vitodens 200-W gas condensing system boiler with separate DHW cylinder	Vitodens 222-W with integral DHW loading cylinder	Vitodens 222-F with integral DHW loading cylinder	Vitodens 242-F with integral, du- al mode DHW loading cylinder
DHW de- mand, con- venience	DHW demand for an apartment	+	+	+	+
	DHW demand for a detached house	+	+	+	+
	Centralised DHW demand for an apartment building	+	–	–	+
	Decentralised DHW demand for an apartment building	+	0	0	–
Use of the various connected draw-off points	One draw-off point	0	0	0	0
	Several draw-off points, not used simultaneously	+	+	+	+
	Several draw-off points, used simultaneously	+	+	+	–
Distance of draw-off point from boiler	Up to 7 m (without DHW circulation pipe)	+	+	–	–
	With DHW circulation pipe	+	–	+	+
Modernisa- tion	DHW cylinder installed	+	–	–	–
	Replacement of an existing combi boiler	–	0	0	–
Space available	Minimal space available (siting in a recess)	0	0	0	0
	Sufficient space available (installation room)	+	+	+	+

Design information (cont.)

		Vitodens 200-W gas condensing system boiler with separate DHW cylinder	Vitodens 222-W with integral DHW loading cylinder	Vitodens 222-F with integral DHW loading cylinder	Vitodens 242-F with integral, du- al mode DHW loading cylinder
Solar DHW heating can be connec- ted	Connection to dual mode DHW cylinder	+	-	-	-
	Connection to integral DHW cylinder	-	-	-	+

+ = recommended

0 = recommended under certain conditions

- = not recommended

Separate DHW cylinders

For greater DHW convenience, separate DHW cylinders are also available in white in the following versions:

- Below the boiler (120 or 150 l)
- Adjacent to the boiler (160, 200, 300 or 400 l)

Further DHW cylinders with up to 1000 l capacity are available in Vitosilver and may also be used in accordance with the available heating output.

The Vitodens 200-W is equipped at factory with a separate DHW cylinder for DHW heating. A diverter valve is integrated for this purpose.

For the connection of a separate DHW cylinder, a DHW cylinder connection set (incl. cylinder temperature sensor) must always be ordered separately.

For DHW cylinder specifications, see chapter "DHW cylinders".

Sizing the DHW cylinder

Determine the DHW cylinder size in accordance with the specific DHW demand.

Various combinations of taps/draw-off points can be applied.

If identical taps/draw-off points are combined, only take into account the individual draw-off point, not the combination.

The following summary enables an **approximate** sizing of the DHW cylinder:

Small households (1 to 2 occupants)	
Average households (3 to 4 occupants)	

Cylinder capacity in litres

	Bath 1600 to DIN 4471	Bath 1700 to DIN 4471	Small bath and sit bath	Large bath (1800 × 750 mm)	Shower cubicle with mixer tap and standard shower head	Shower cubicle with 1 shower head and 2 side noz- zles	Washbasin	Bidet
Draw-off rate in W/h	5820	6510	4890	8720	1630	4070	700	810
Draw-off volume per use or useful capacity in l	140	160	120	200	40	100	17	20
Bath 1600 to DIN 4471	120				120	120	120	120
	120				120	150/160	120	120
Bath 1700 to DIN 4471		120			120	120	120	120
		120			120	120	120	120
Small bath and sit bath			120		120	120	120	120
			120		120	120	120	120
Large bath (1800 × 750 mm)				120	120	120	120	120
				200	150/160	200	150/160	150/160
Shower cubicle with mixer tap and standard shower head	120	120	120	120	120	120	120	120
	120	120	120	150/160	120	120	120	120
Shower cubicle with 1 shower head and 2 side nozzles	120	120	120		120	120	120	120
	150/160		150/160	200	120	120	120	120
Washbasin	120	120	120	120	120	120	120	120
	120	120	120	150/160	120	120	120	120
Bidet	120	120	120	120	120	120	120	120
	120	120	120	150/160	120	120	120	120

Example:

- Average household with 3 occupants
- Use of a bath 1600 with 140 l drawn
- Simultaneous operation of a shower with mixer tap and standard head with 40 l drawn

The table shows that in accordance with DIN 4708, the correct DHW cylinder would have a capacity of 120 l.

Design information (cont.)

DHW cylinder selection tables

DHW cylinders with "-W" in the product name are supplied with a white finish. Appliances with "-B" or "-V" in the product name are supplied in Vitosilver (marked in grey in the table).

Vitodens 200-W gas system boilers, cylinder allocation

Rated heating output range [kW]	Practical cylinder allocation (cylinder capacity in litres)		
	up to 19.0	25.0	32.0
Vitocell 100-W (type CUGA, CUGA-A) below the boiler	120 150	120 150	120 150
Vitocell 100-W (type CVA, CVAA, CVAA-A) adjacent to the boiler	160 200 300	160 200 300	160 200 300
Vitocell 100-V (type CVA) adjacent to the boiler	—	—	500
Vitocell 200-W (type EVIA-A) adjacent to the boiler	160 200	160 200	160 200
Vitocell 300-V (type EVIA-A) adjacent to the boiler	—	300 500	300 500
Vitocell 100-W (type CVB, CVBB) adjacent to the boiler, dual mode	300 400	300 400	300 400
Vitocell 100-W (type CVUB) adjacent to the boiler, dual mode	300	300	300
Vitocell 100-W (type CVUC-A) adjacent to the boiler, dual mode (for Vitodens 200-W only)	300	300	300
Vitocell 100-B (type CVB) adjacent to the boiler, dual mode	—	500	500
Vitocell 300-B (type EVBA-A) adjacent to the boiler, dual mode	300	300 500	300 500
Vitocell 340-M (type SVKC) heating water buffer cylinder with DHW heating	708/30	708/30	708/30
Vitocell 360-M (type SVSB) heating water buffer cylinder with DHW heating	708/30	708/30	708/30

8.3 Connections on the water side

Connection on the DHW side

Vitodens 200-W gas condensing combi boiler

For the DHW connection, connection sets for surface or flush mounting are available as accessories. The instantaneous water heater provides direct DHW heating.

If used in conjunction with galvanised pipes, note that the instantaneous water heater is designed as a stainless steel plate heat exchanger with copper solder joints (observe the flow rule).

In existing installations (modernisation projects), the risk of electrolytic corrosion is low, since a protective layer will have formed on the inside of the pipes.

If DHW is to be drawn simultaneously from several points, we recommend the installation of a separate DHW cylinder in conjunction with the gas system boiler (see "Decision making aids regarding DHW heating").

With water hardness of 20 °dH and higher, we recommend the use of a water treatment system in the cold water line when heating DHW.

Design information (cont.)

Cold water installation of Vitodens 200-W gas condensing combi boiler

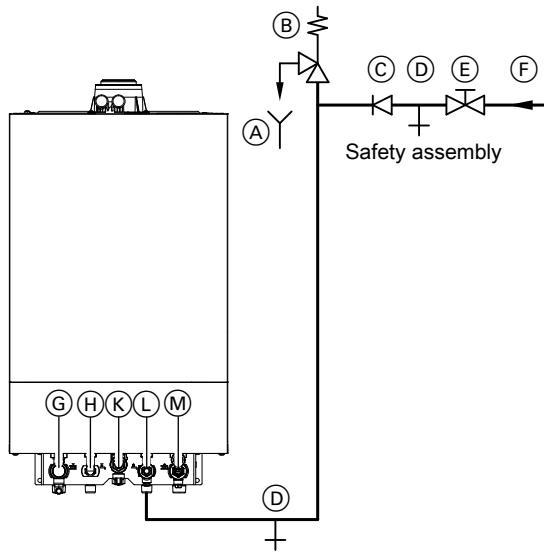

- (A) Visible drain pipe outlet point
- (B) Safety valve
- (C) Non-return valve
- (D) Drain outlet
- (E) Shut-off valve
- (F) Cold water
- (G) Heating flow
- (H) DHW
- (K) Gas connection
- (L) Cold water
- (M) Heating return

A safety valve to DIN 1988 only has to be installed if the mains water supply pressure exceeds 10 bar (1 MPa), (A): 6 bar (0.6 MPa), and no DHW pressure reducing valve is used (in accordance with DIN 4753).

Install a safety valve if the cold water supply is equipped with a non-return valve. In addition remove the toggle from the cold water shut-off valve.

Non-return valves are commonly found in pressure reducers and combined shut-off and non-return valves.

Shock arrestor

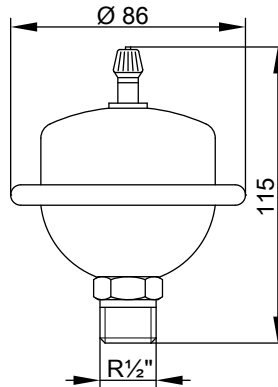

If the pipework to which the Vitodens is connected also supplies draw-off points at which water hammers may occur (e.g. pressure washers, washing machines or dishwashers): Install shock arrestors near the source of the water hammer (recommended).

Flexofit S made by Flamco-Flexcon

or

Reflex made by Winkelmann + Pannhoff GmbH (available from your local dealer).

Design information (cont.)

Vitodens 200-W connection on the DHW side with separate DHW cylinder and Vitodens 222-W with integral loading cylinder

Example:

DHW cylinder below the boiler (120 or 150 l) with safety assembly to DIN 1988

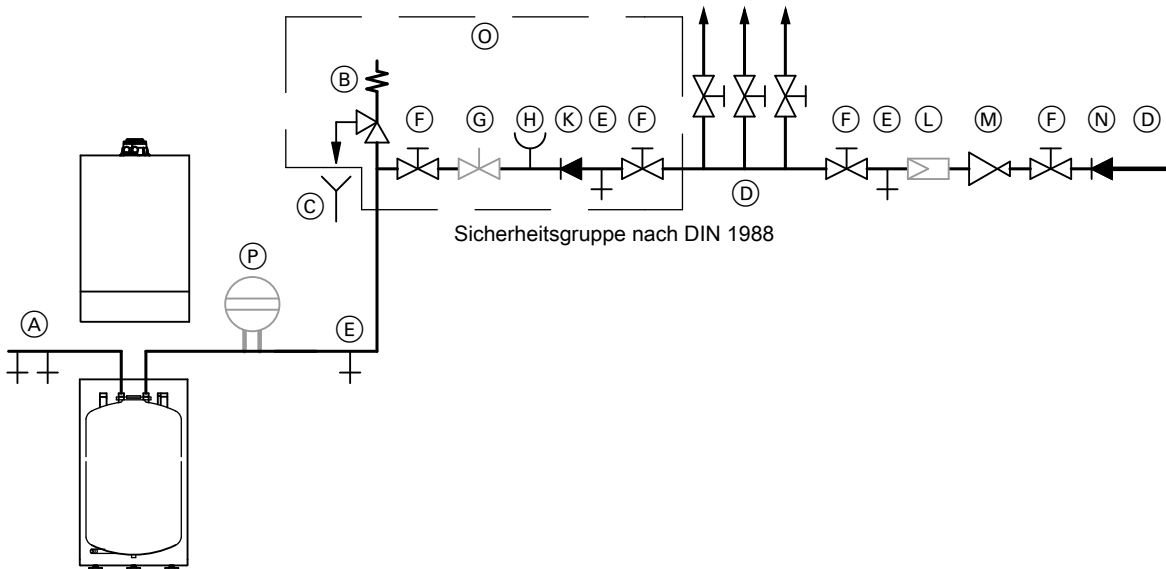

- | | |
|--|---|
| <ul style="list-style-type: none"> (A) DHW (B) Safety valve
Included in the standard delivery of the pre-plumbing jig for Vitodens 222-W (C) Visible discharge pipe outlet point (D) Cold water (E) Drain outlet (F) Shut-off valve (G) Flow regulating valve (installation recommended) | <ul style="list-style-type: none"> (H) Pressure gauge connector (K) Non-return valve (L) Drinking water filter (M) Pressure reducer to DIN 1988-2, Dec. 1988 version (N) Non-return valve/pipe separator (O) Standard delivery of the safety assembly available as an accessory (for separate DHW cylinders only) (P) Diaphragm expansion vessel, suitable for potable water |
|--|---|

Safety valve

The safety valve **must** be installed.

We recommend you install the safety valve higher than the top edge of the cylinder. This protects the valve against contamination, scaling and high temperatures. It also means that the DHW cylinder does not need to be drained when working on the safety valve.

Drinking water filter

Install a drinking water filter in accordance with DIN 1988-200.

DHW circulation

Only in conjunction with the Vitodens 200-W. Cannot be used with the Vitodens 222-W because of the integral loading cylinder. DHW circulation pipes increase DHW convenience and reduce water consumption. These benefits result from the immediate availability of DHW at the tap/draw-off point.

However, poor thermal insulation of the DHW circulation pipe can lead to substantial heat losses.

From a **pipe length of 7 m** upwards, we recommend the installation of a DHW circulation pipe with appropriate thermal insulation in accordance with the Energy Saving Ordinance. The Energy Saving Ordinance specifies that the DHW circulation pipe should include a circulation pump, check valve and time switch for stopping DHW circulation during the night.

Power supply for DHW circulation pump

DHW circulation pumps equipped with their own internal control unit must be connected via a separate power supply. Connecting the power supply via the heat generator control unit or its accessories is **not** permissible.

Using a non-return valve

If using a DHW cylinder adjacent to the boiler, we recommend installing a non-return valve in the heating water connection line to prevent the DHW cylinder cooling due to any recirculation that may occur.

Design information (cont.)

Vitodens 200-W

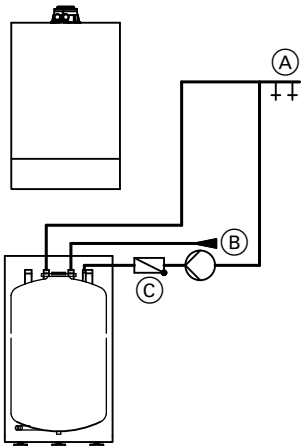

DHW cylinder below the boiler

- (A) DHW
- (B) Cold water
- (C) DHW circulation

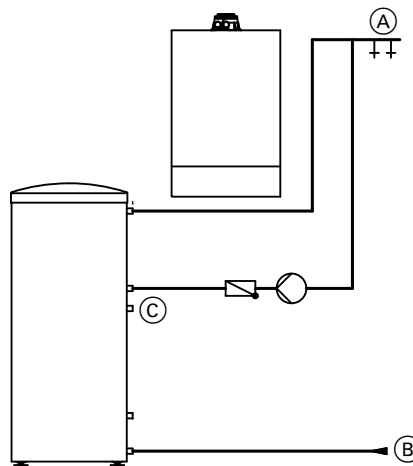

DHW cylinder adjacent to the boiler

- (A) DHW
- (B) Cold water
- (C) DHW circulation

Vitodens 222-F and 242-F connection on the DHW side

If used in conjunction with galvanised pipes, note that plate heat exchangers with copper solder joints are integrated into the Vitodens 222-F and 242-F with cylinder loading system (observe the flow rule).

Cold water installation

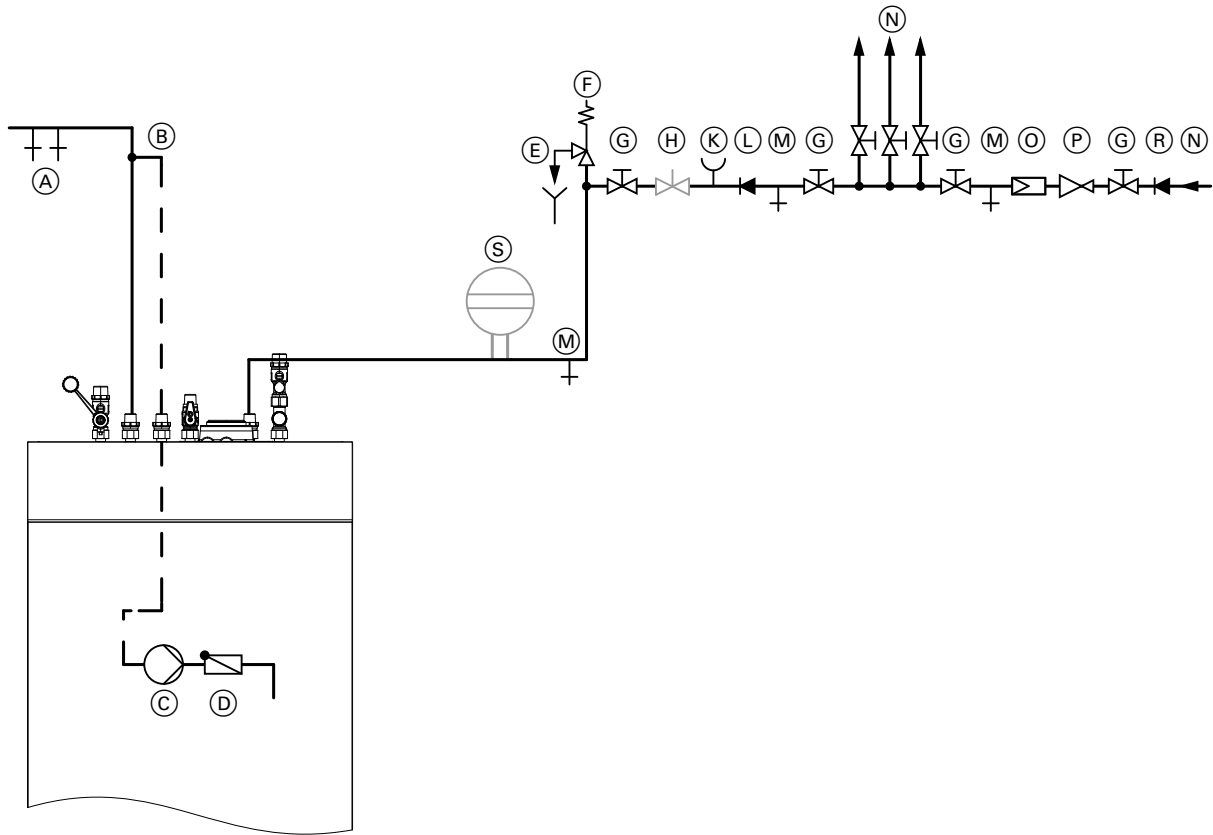

For connection locations, see the relevant connection set

- | | |
|--|--|
| <ul style="list-style-type: none"> (A) DHW (B) DHW circulation pipe (C) DHW circulation pump (D) Spring-loaded check valve (E) Visible discharge pipe outlet point (F) Safety valve (G) Shut-off valve (H) Flow regulating valve <p>(We recommend installation and adjustment of the max. water flow rate in accordance with the peak draw-off rate of the DHW cylinder (see "Specification"))</p> | <ul style="list-style-type: none"> (K) Pressure gauge connector (L) Non-return valve (M) Drain outlet (N) Cold water (O) Drinking water filter (P) Pressure reducer (R) Non-return valve/pipe separator (S) Diaphragm expansion vessel, suitable for potable water |
|--|--|

Note

The DHW circulation pump connection set (accessories) contains a DHW circulation pump (C) and check valve (D). The components are installed in the boiler.

Safety valve

The safety valve **must** be installed.

DHW circulation

DHW circulation pipes increase DHW convenience and reduce water consumption. These benefits result from the immediate availability of DHW at the tap/draw-off point. However, poor thermal insulation of the DHW circulation pipe can lead to substantial heat losses.

From a **pipe length of 7 m** upwards, we recommend the installation of a DHW circulation pipe with appropriate thermal insulation in accordance with the Energy Saving Ordinance. The Energy Saving Ordinance specifies that the DHW circulation pipe should include a circulation pump, check valve and time switch for stopping DHW circulation during the night.

We recommend installing the safety valve above the top edge of the cylinder. This protects the valve against contamination, scaling and high temperatures. It also means that the DHW cylinder does not need to be drained when working on the safety valve.

Only use the DHW circulation pump connection set, available as an accessory, for installation in the boiler. The circulation pump is then controlled by the boiler control unit. The flow rate of the DHW circulation pump must not exceed **1.5 l/min**.

Installation scheme for DHW circulation, see page 131.

Power supply for DHW circulation pump

DHW circulation pumps equipped with their own internal control unit must be connected via a separate power supply. Connecting the power supply via the heat generator control unit or its accessories is not permissible.

8.4 Condensate connection

Route the condensate drain pipe with a constant fall. Route the condensate from the flue system together with the boiler condensate directly or via a neutralising system (if installed – accessories) to the public sewage system.

Vitodens 200-W

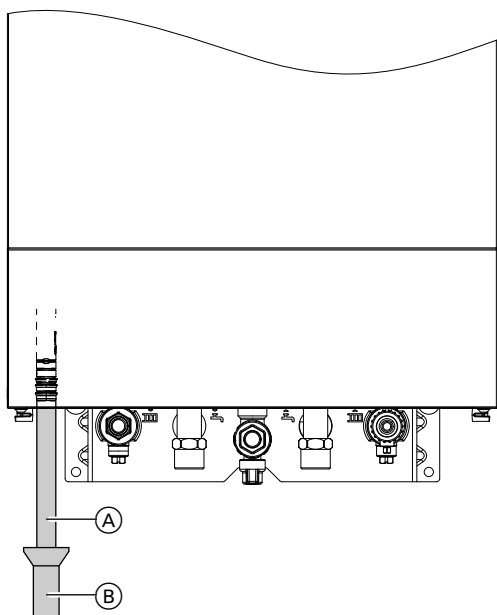

- (A) Drain hose (Vitodens standard delivery)
- (B) Drain outlet kit (accessories)

Note

A pipe vent **must** be installed between the trap and the neutralising system.

Vitodens 222-W

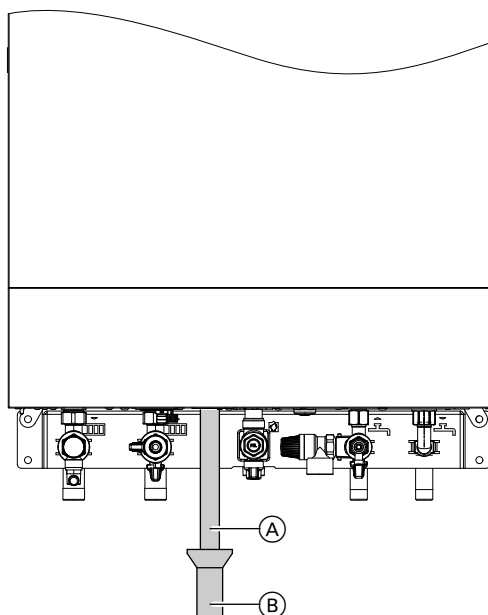

- (A) Drain hose (Vitodens standard delivery)
- (B) Drain outlet kit (accessories)

Vitodens 222-F

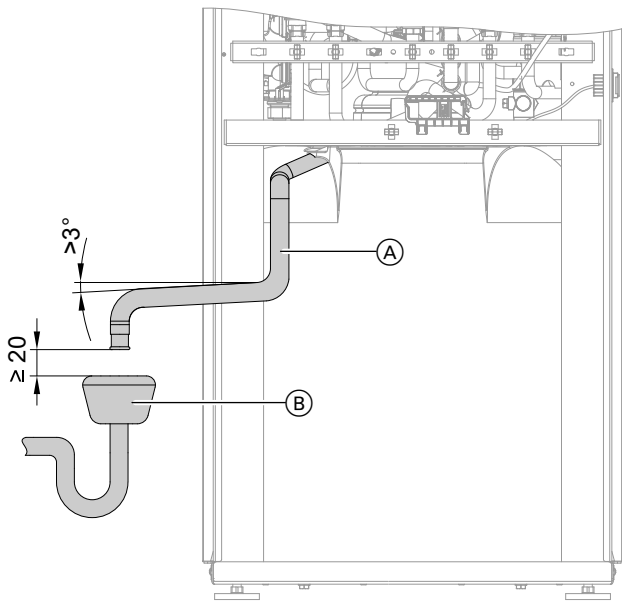

- (A) Drain hose (Vitodens standard delivery)
- (B) Trap and pipe vent

Vitodens 242-F

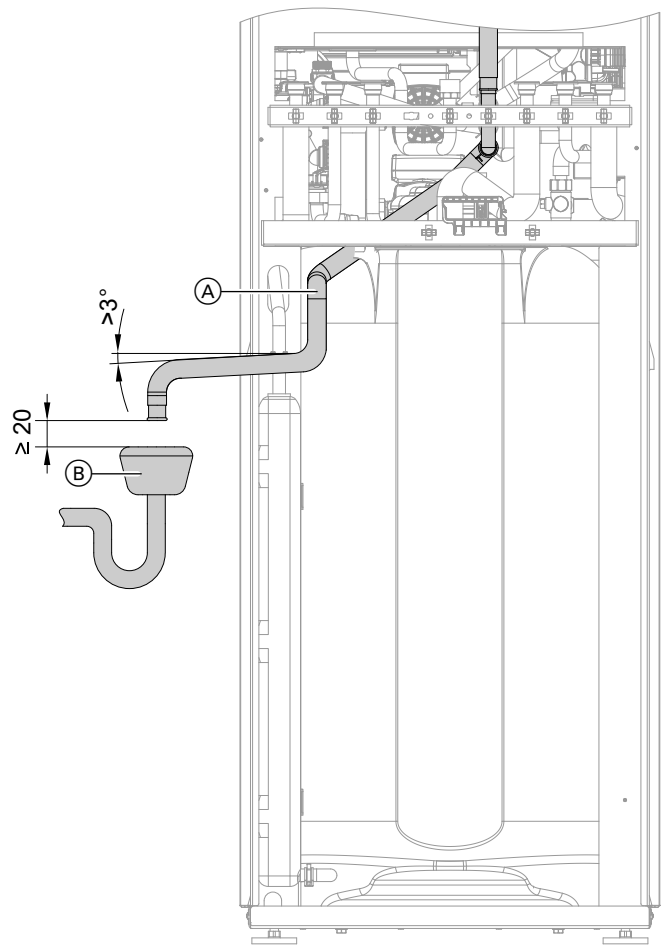

- (A) Drain hose (Vitodens standard delivery)
- (B) Trap and pipe vent

Condensate drain pipe and neutralisation

During heating operation, condensate with pH values between 4 and 5 is formed in the condensing boiler and in the flue.

The condensate should be drained in accordance with appropriate regulations.

Code of Practice DWA-A 251 on "Condensate from condensing boilers", which is generally based on the local waste water regulations [in Germany], determines conditions for draining condensate from condensing boilers into the public sewer system.

The composition of condensate drained from Vitodens condensing boilers meets the requirements specified in Code of Practice DWA-A 251.

The condensate drain pipe to the sewer connection must be freely accessible for inspection.

It must be installed with a continuous fall and must contain a stench trap. Also provide a suitable facility for sampling.

Condensate drain pipes must only be made from corrosion-resistant materials (e.g. reinforced hoses).

Never use any zinc-plated materials or those containing copper for pipes, connection pieces, etc.

A trap is installed in the condensate drain to prevent flue gases escaping.

Local water regulations and/or specific technical circumstances may prescribe designs which vary from those described in the above Codes of Practice.

Contact your local authority responsible for waste water management in good time prior to installation, to find out about local regulations.

Condensate from gas combustion equipment up to 200 kW combustion output

Up to a rated heating output of 200 kW, the condensate from a gas condensing boiler can generally be introduced into the public sewerage system without prior neutralisation.

Domestic drainage systems must be made from materials that are resistant to acidic condensate.

According to the Code of Practice DWA-A 251, these materials include:

- Vitrified clay pipes
- Hard PVC pipes
- PVC pipes
- PE HD pipes
- PE pipes
- ABS/ASA pipes
- Stainless steel pipes
- Borosilicate pipes

Neutralising system

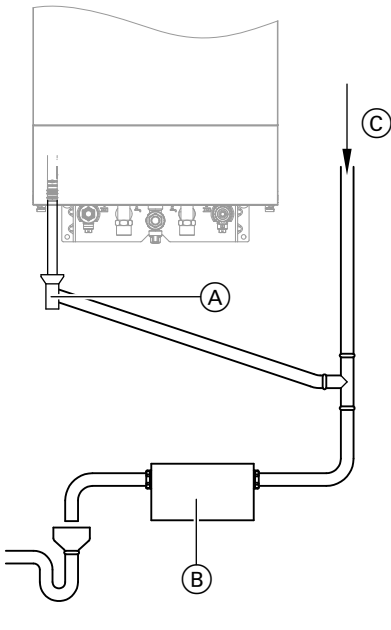

- Ⓐ Condensate drain
- Ⓑ Neutralising system
- Ⓒ Ventilation via the roof

The Vitodens can (if required) be supplied with a separate neutralising system (accessories, see page 69). Any condensate is piped to and processed in the neutralising system. The condensate drain pipe to the sewer connection must be accessible for inspection. Install it with a fall and a stench trap on the sewer side, and provide a suitable facility for extracting samples.

Install a condensate lifting pump if the Vitodens has been installed below the waste water anti-flooding level. Condensate lifting pumps are available as accessories. Since the consumption of neutralising granulate depends on the operating mode of the system, carry out regular checks during the first year of operation to determine the required top-up volume. One fill can last longer than one year.

Condensate removal pump (accessories)

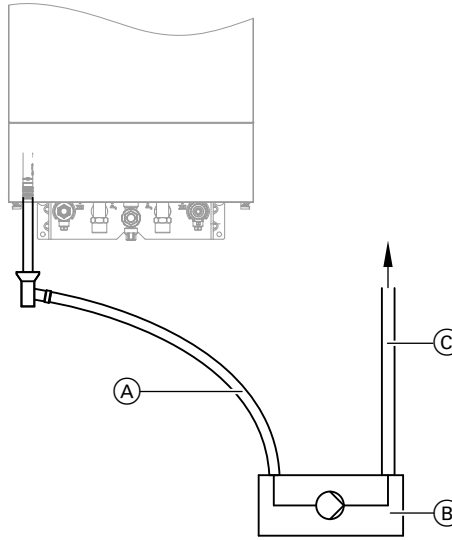

- Ⓐ Condensate inlet
- Ⓑ Condensate removal pump
- Ⓒ Condensate drain

8.5 Hydraulic connection

General

System design

Viessmann condensing boilers can generally be installed in any fully pumped hot water heating system (sealed unvented system). The circulation pump is an integral part of the appliance. Minimum system pressure 1.0 bar (0.1 MPa). The boiler water temperature is limited to 82 °C. To minimise distribution losses, we recommend sizing the heat distribution system to a max. flow temperature of 70 °C. Due to the immediate capture of the room influence factors, we recommend using the Vitodens in conjunction with the Vitotrol 200-E for apartments with less than 80 m² living space or for low energy houses with a low heat demand. The heat generator must be correctly sized and selected.

Chemical anti-corrosion agents

According to VDI guideline 2035, the design of heating systems must ensure they are sealed against corrosion. Additives in the heating water (additives, chemicals) as corrosion protection measures are normally not necessary. Exception: In systems without system separation, for example, additives can be considered.

Heating circuits

For heating systems with plastic pipes, we recommend the use of impermeable pipes to prevent the diffusion of oxygen through the pipe walls.

Provide system separation in heating systems with plastic pipes that are permeable to oxygen (DIN 4726). A separate heat exchanger for this purpose is available. Install a dirt separator in underfloor heating systems. See Viessmann Vitoset pricelist. Underfloor heating systems and heating circuits with very large water content (>15 l/kW) should be connected to the condensing boiler via a 3-way mixer. See technical guide "Control of underfloor heating systems" or the relevant sample applications. Install a temperature limiter in the flow of the underfloor heating circuit to restrict the maximum temperature. Observe the requirements of DIN 18560-2 [or local regulations].

Plastic pipework for radiators

We also recommend the use of a temperature limiter to restrict the maximum temperature for plastic pipework in heating circuits with radiators.

Attic heating centre

The installation of a low water indicator, compulsory according to the DVGW [Germany], is not required when installing boilers in an attic heating centre. The boilers are protected against water shortage in accordance with EN 12828.

Safety valve

A safety valve in accordance with TRD 721 is integrated in the Vitodens (opening pressure 3 bar (0.3 MPa)).

Design information (cont.)

Route the discharge pipe in accordance with EN 12828 into a drain outlet (drain outlet kit available as an accessory). The drain outlet incorporates a siphon as a stench trap.

Low water indicator

According to EN 12828, a low water indicator can be omitted for boilers up to 300 kW, as long as heating can be reliably prevented when there is a water shortage.

Viessmann condensing boilers are equipped with a low water indicator (boil-dry protection). Tests have verified that the burner will be automatically switched off in the event of water shortage due to a leak in the heating system and simultaneous burner operation, before the boiler or the flue system reaches unacceptably high temperatures.

Water quality/frost protection

Unsuitable fill and top-up water increases the level of deposits and corrosion and may lead to boiler damage.

Observe VDI guideline 2035 regarding the quality and volume of heating water, incl. fill and top-up water.

CH: Observe SWKI guideline BT 102-01.

- Flush the heating system thoroughly before filling.
- Only fill with water of potable quality.
- VDI guideline 2035 recommends water softening treatment to prevent harmful scaling in the heating water. Additives to stabilise hardness do not remove the scale forming chemicals from the heating water. Fill and top-up water with a water hardness in excess of the following values must be softened, e.g. with the small softening system for heating water (see the Viessmann Vitoset pricelist):

Total permissible hardness of the fill and top-up water

Total heating output kW	Specific system volume		
	< 20 l/kW	≥ 20 l/kW to < 50 l/kW	≥ 50 l/kW
≤ 50	≤ 3.0 mol/m ³ (16.8 °dH)	≤ 2.0 mol/m ³ (11.2 °dH)	< 0.02 mol/m ³ (0.11 °dH)
> 50 to ≤ 200	≤ 2.0 mol/m ³ (11.2 °dH)	≤ 1.5 mol/m ³ (8.4 °dH)	< 0.02 mol/m ³ (0.11 °dH)

- For systems with a specific system volume in excess of 20 l/kW heating output, use the output of the smallest boiler in multi boiler systems.
- Special antifreeze (category 1 to 3) suitable for heating systems can be added to the fill water. The use of glycols without sufficient inhibition and buffering is not permitted. The suitability of the antifreeze must be confirmed by the manufacturer. If antifreeze is added, more monitoring and maintenance is necessary. Observe the manufacturer's instructions. Viessmann accepts no liability for damage and malfunctions caused by unsuitable or incorrectly dosed antifreeze, or incorrect maintenance.

Expansion vessels

In accordance with EN 12828, water heating systems must be equipped with an expansion vessel.

An expansion vessel is integrated in the boilers:

- Vitodens 200-W and 222-W: Capacity 10 l
- Vitodens 222-F and 242-F: Capacity 18 l

Pre-charge pressure in the delivered condition: 0.75 bar (0.075 MPa)
Determine the size of the expansion vessel to be installed in accordance with EN 12828.

- EN 1717 and DIN 1988-100 must be observed if the heating water is used simultaneously as a heat transfer medium for DHW heating.
- When disposing of heating water that contains additives, check whether it may be discharged into the public drain network once it has been treated again.

When designing the system, observe the following:

- Install shut-off valves in each section. This prevents the need for draining all the heating water in the case of repairs or system expansion.
- In systems > 50 kW, install a water meter to record the volume of fill and top-up water. Record the amount of water filled into the system and the water hardness.

Operating information:

- Commission the system step by step, starting with the lowest boiler output and a high heating water flow rate. This prevents localised concentration of limescale deposits on the heating surfaces.
- In multi boiler systems, start all boilers simultaneously to prevent the total amount of limescale deposits settling in the heat exchanger of just one boiler.
- During expansion or repair work, only drain the necessary pipe-work sections.
- Where water treatment is required, treat even the first fill of the heating system prior to commissioning. This also applies to any subsequent filling, e.g. when adding top-up water or after a repair, or for any system expansion.
- Check, clean and activate filters, dirt traps and other blow down or separating facilities in the heating water circuit more frequently after commissioning and in new installations. Later on this can be carried out subject to the requirements of the water treatment applied (e.g. water softening).

Installation examples

For installation examples, see "www.viessmann-schemes.com".
Never install the Vitodens 222-W in dual mode systems with solid fuel boilers.

If the integral expansion vessel is insufficient, install a suitably sized expansion vessel on site.

Note

When hydraulically connecting the diaphragm expansion vessel, ensure that there is always a connection between the diaphragm expansion vessel and the heat generator.

For example, when the thermostat valves are closed and if the 3-way diverter valve is set to "DHW". The 3-way diverter valve is installed in the heating water flow.

Low loss header

Application

Design rules for system hydraulics:

- When balancing the low loss header, adjust the flow rate on the equipment side to approx. 10 to 30 % below the flow rate on the system side (reducing the return temperature).
- The low loss header should be sized for the max. flow rate which may occur in the overall system.

The low loss header separates the heat generator circuit (boiler circuit) from the downstream heating circuits.

A low loss header must be used if the max. flow rate of an individual design is greater than the possible flow rate as shown on the relevant "Residual head" graph.

For installation schemes in conjunction with low loss headers, see "www.viessmann-schemes.com".

Heat generator circuit

The circulation pump in the Vitodens must be able to deliver the required water volume against the (mostly low) pressure drop of the heat generator circuit; the pressure drop of the low loss header is negligible. The pump graphs are used to find the relevant residual head for determining the internal pipe diameters, subject to the water volume circulating in the heat generator circuit.

Heating circuit

The heating circuit pumps to be installed on site must be able to deliver the water volume in the heating circuits against their pressure drop. They must be sized accordingly.

Principle of operation

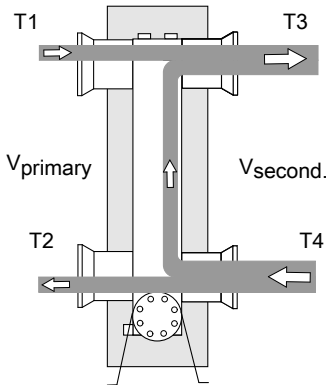

- $V_{primary}$ Heating water volume in the heat generator circuit (approx. 10 to 30 % less than $V_{secondary}$)
- $V_{secondary}$ Heating water volume, heating circuit
- T_1 Flow temperature, heat generator circuit
- T_2 Return temperature, heat generator circuit
- T_3 Flow temperature, heating circuit
- T_4 Return temperature, heating circuit
- $Q_{primary}$ Amount of heat supplied by the heat generator
- $Q_{secondary}$ Amount of heat transferred by the heating circuit

$V_{primary} < V_{secondary}$
 $T_1 > T_3$
 $T_2 \approx T_4$
 $Q_{primary} = Q_{secondary}$

Note

Thermometers in the flow and return to the low loss header make adjustments easier.

Low loss header (separate accessories)

See Vitodens installation accessories, page 93

Low loss header in conjunction with Divicon

	Max. flow rate in m ³ /h
Low loss header	
- R ¾	4.5
- R 1	4.5
- R 1¼	7.5
Divicon heating circuit distributor	
- R ¾	1.0
- R 1	1.5
- R 1¼	2.5

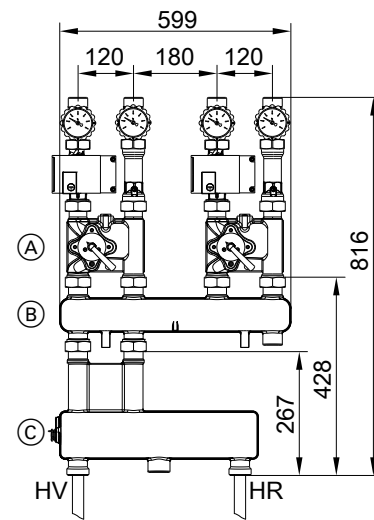

- HR Heating return
- HV Heating flow
- (A) Divicon heating circuit distributor
- (B) Manifold
- (C) Low loss header

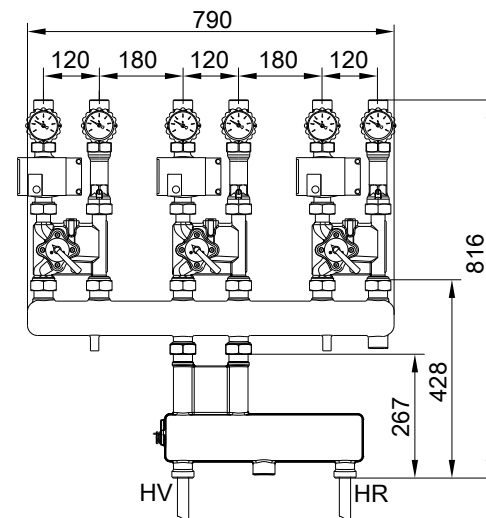

- HR Heating return
- HV Heating flow

8.6 Intended use

The appliance is intended solely for installation and operation in sealed unvented heating systems that comply with EN 12828, with due attention paid to the associated installation, service and operating instructions. It is only designed for heating up heating water that is of potable water quality.

Intended use presupposes that a fixed installation in conjunction with permissible, system-specific components has been carried out.

Commercial or industrial usage for a purpose other than heating the building or DHW shall be deemed inappropriate.

Any usage beyond this must be approved by the manufacturer in each individual case.

Incorrect usage or operation of the appliance (e.g. the appliance being opened by the system user) is prohibited and will result in an exclusion of liability. Incorrect usage also occurs if the components in the heating system are modified from their intended use (e.g. if the flue gas and ventilation air paths are sealed).

Control unit

9.1 Layout and functions

Control unit with 7-inch screen – modular design

The control unit is integrated into the Vitodens.

The control unit comprises electronics modules and a programming unit:

- HMI programming unit with 7" colour touchscreen and integral wireless module
- HMU electronics module:
 - For connecting actuators and sensors
 - For connecting accessories via PlusBus
- BCU (burner control unit) electronics module for electronic combustion control
- Status indicator (Lightguide) for operating and fault display

The control unit can be set to the following operating modes:

- Weather-compensated operation
 - An outside temperature sensor (accessories) must be connected.
- Constant operation
 - Operation with constant flow temperature
- Room temperature-dependent operation
 - A room temperature controller/room thermostat (accessories) must be connected to plug 96. Only one heating circuit without mixer in the system.

Programming unit

- Easy operation through:
 - Colour touchscreen with plain text and graphic display
 - Large font and colour depiction for good contrast
 - Context-sensitive help texts
- Connectivity via:
 - Integral WiFi interface
 - Access point mode
 - Low power radio
- With digital time switch
- Touchscreen for:
 - Navigation
 - Settings
 - Confirmation
 - Help and additional information
 - Menu

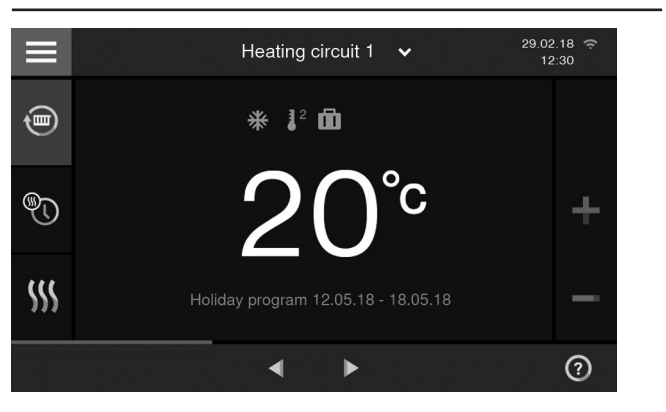

- Adjustment of:
 - Set room temperature
 - Reduced
 - Standard
 - Comfort
 - Set DHW temperature
 - One-off cylinder heat-up
 - Operating programs for central heating and DHW heating
 - Time programs for central heating, DHW heating and DHW circulation
 - Extended heating
 - Holiday program
 - Holiday at home
 - Heating curves
 - Hygiene function (increased DHW hygiene)
 - Parameter
 - Actuator tests
 - Test mode

Control unit (cont.)

- Display of:
 - Outside temperature
 - Heat generator flow temperature
 - Flow temperature in heating circuits with mixer
 - DHW temperature
 - Operating data
 - Energy consumption values (in the energy cockpit)
- Diagnostic details
- Fault messages
- Available languages:
 - German
 - Czech
 - Danish
 - English
 - French
 - Italian
 - Dutch
 - Polish
 - Slovak
 - Swedish
 - Estonian
 - Croatian
 - Latvian
 - Lithuanian
 - Bulgarian
 - Romanian
 - Russian
 - Slovenian
 - Spanish
 - Turkish
 - Hungarian

Control unit with 3.5-inch screen – modular design

The control unit is integrated into the Vitodens.

The control unit comprises electronics modules and a programming unit:

- HMI programming unit with 3.5" black/white screen and integral wireless module
- HMU electronics module:
 - For connecting actuators and sensors
 - For connecting accessories via PlusBus
- BCU (burner control unit) electronics module for electronic combustion control
- Status indicator (Lightguide) for operating and fault display

The control unit can be set to the following operating modes:

- Weather-compensated operation
 - An outside temperature sensor (accessories) must be connected.
- Constant operation
 - Operation with constant flow temperature
- Room temperature-dependent operation
 - A room temperature controller/room thermostat (accessories) must be connected to plug 96. Only one heating circuit without mixer in the system.

Programming unit

- Easy operation through:
 - Black/white screen with plain text display
 - Context-sensitive help texts
- Connectivity via:
 - Integral WiFi interface
 - Access point mode
 - Low power radio
- With digital time switch
- Touchscreen for:
 - Navigation
 - Settings
 - Confirmation
 - Help and additional information
 - Menu
- Adjustment of:
 - Set room temperature
 - Reduced
 - Standard
 - Comfort
 - Set DHW temperature
 - One-off cylinder heat-up
 - Operating programs for central heating and DHW heating
 - Time programs for central heating, DHW heating and DHW circulation
 - Extended heating
 - Holiday program
 - Holiday at home
 - Heating curves
 - Hygiene function (increased DHW hygiene)
 - Parameter
 - Actuator tests
 - Test mode

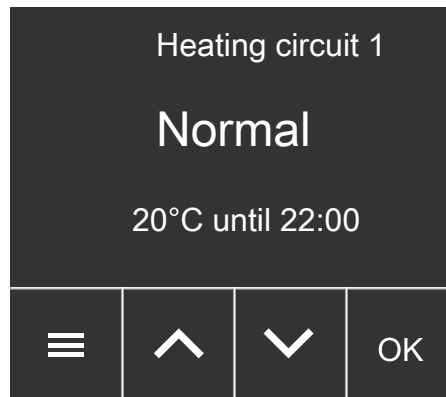

Control unit (cont.)

- Display of:
 - Outside temperature
 - Heat generator flow temperature
 - Flow temperature in heating circuits with mixer
 - DHW temperature
 - Operating data
- Diagnostic details
- Fault messages
- Available languages:
 - German
 - Czech
 - Danish
 - English
 - French
 - Italian
 - Dutch
 - Polish
 - Slovak
 - Swedish
 - Estonian
 - Croatian
 - Latvian
 - Lithuanian
 - Bulgarian
 - Romanian
 - Russian
 - Slovenian
 - Spanish
 - Turkish
 - Hungarian

Functions

Control unit with 7-inch screen

- Control of the flow temperature (selectable):
 - Weather-compensated
 - Constant
 - Room temperature-dependent
- Control of 1 heating circuit without mixer
- Control of max. 2 heating circuits with mixer (accessories)
- Electronic maximum and minimum temperature limit
- Demand-dependent heating circuit pump and burner shutdown control
- Variable heating limit setting
- Automatic winter/summertime changeover
- Individually programmable switching times for central heating and DHW heating.
 - Max. 4 time phases for each per day
- Heating system frost protection monitoring
- Integral diagnostic system
- Service indicator
- Commissioning via commissioning assistant
- Cylinder temperature controller with priority control
- Hygiene function for DHW heating (short-term heating to a higher temperature)
- In conjunction with the EM-S1 extension module (only for Vitodens 200-W and 242-F):
 - Control of solar DHW heating
 - Or
 - Central heating backup with combi cylinder

Note

See also: www.viessmann-schemes.com

- Simultaneous screed drying program for all heating circuits (choice of 6 stored programs)
- Connection option for extension modules

Control unit with 3.5-inch screen

- Control of the flow temperature (selectable):
 - Weather-compensated
 - Constant
 - Room temperature-dependent
- Control of 1 heating circuit without mixer

- Control of max. 2 heating circuits with mixer (accessories)
- Electronic maximum and minimum temperature limit
- Demand-dependent heating circuit pump and burner shutdown control
- Variable heating limit setting
- Automatic winter/summertime changeover
- Individually programmable switching times for central heating and DHW heating.
 - Max. 4 time phases for each per day
- Heating system frost protection monitoring
- Integral diagnostic system
- Service indicator
- Commissioning via commissioning assistant
- Cylinder temperature controller with priority control
- Hygiene function for DHW heating (short-term heating to a higher temperature)
- In conjunction with the EM-S1 extension module (only for Vitodens 200-W and 242-F):
 - Control of solar DHW heating
 - Or
 - Central heating backup with combi cylinder

Note

See also: www.viessmann-schemes.com

- Simultaneous screed drying program for all heating circuits (choice of 6 stored programs)
- Connection option for extension modules

To reduce the heat-up output, the reduced room temperature can be raised when outside temperatures are low. To shorten the heat-up time after a setback phase the flow temperature is raised for a limited time.

According to the [German] Energy Saving Ordinance, the temperature in each room must be individually controlled, e.g. by means of thermostatic valves.

Control unit (cont.)

Information on PlusBus subscribers

Only the following PlusBus subscribers can be connected to the control unit:

- 2 EM-M1 or EM-MX extensions (ADIO electronics module)
- 2 Vitotrol 200-E
- 3 EM-EA1 extensions (DIO electronics module)

- 1 EM-S1 extension (ADIO or SDIO/SM1A electronics module)
- 1 EM-P1 extension (ADIO electronics module)

The max. total length of the PlusBus lead is 50 m.
With an unscreened lead, 2-core, 0.34 mm².

Frost protection function

- The frost protection function will start when the outside temperature falls below approx. +3 °C.
With active frost protection, the heating circuit pump is switched on and the boiler water is heated up to approx. 20 °C.
The DHW cylinder will be heated to approx. 20 °C.
- The frost protection function will stop when the outside temperature exceeds approx. +5 °C.

Heating curve setting (slope and level)

The flow temperature of the heating circuit without mixer **and** the flow temperature of the heating circuits with mixer (in conjunction with the extension kit for one heating circuit with mixer) are controlled in weather-compensated mode. The flow temperature of the heat generator is therefore automatically regulated to between 0 and 40 K above the currently required set flow temperature (delivered condition 8 K).

The flow temperature required to reach a specific room temperature depends on the heating system and the thermal insulation of the building to be heated.

Adjusting the heating curves matches the boiler water temperature and the flow temperature to these conditions.

Heating curves:

The flow temperature is restricted at the upper end of the scale by the temperature limiter and the maximum temperature set at the electronic maximum temperature limiter.

The flow temperature of the heating circuits cannot exceed the flow temperature of the heat generator.

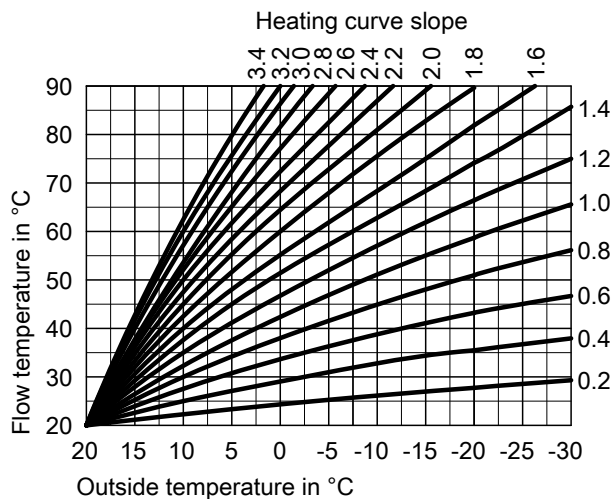

Heating systems with a low loss header or heating water buffer cylinder

When using hydraulic separation (low loss header) or a heating water buffer cylinder, a temperature sensor must be installed in the low loss header or heating water buffer cylinder.

On heating circuits with mixers, the temperature sensor is connected to mixer extension kit EM-M1 or EM-MX.

If only one heating circuit without mixer is available downstream of the low loss header or heating water buffer cylinder, the temperature sensor and the heating circuit pump of the heating circuit without mixer is connected to the EM-P1 extension.

Flow temperature sensor

The flow temperature sensor is connected to the burner control unit (BCU electronics module) and installed in the appliance.

Specification

Sensor type	Viessmann NTC 10 kΩ at 25 °C
Permissible ambient temperature	
– Operation	0 to +130 °C
– Storage and transport	–20 to +70 °C

Cylinder temperature sensor

Standard delivery for:

Vitodens 200-W:

- Part of the standard delivery of the connection set for DHW cylinders below the boiler (120 or 150 l) (order separately)
- Part of the standard delivery of the connection set for DHW cylinders adjacent to the boiler (160 to 400 l) or alternative DHW cylinders (order separately)
- Cylinder temperature sensor (part no. ZK04671)
Required with on-site DHW cylinder

Vitodens 222-W, 222-F and 242-F:

- The cylinder temperature sensor is connected in the control unit and installed in the DHW cylinder
- The outlet temperature sensor is connected in the burner control unit (BCU electronics module) and installed in the boiler

Control unit (cont.)

Specification

Lead length	3.75 m, fully wired
IP rating	IP 32
Sensor type	Viessmann NTC 10 kΩ at 25 °C
Permissible ambient temperature	
– Operation	0 to +90 °C
– Storage and transport	–20 to +70 °C

9.2 Specification – control unit

Rated voltage	230 V~
Rated frequency	50 Hz
Rated current	6 A
Protection class	I
Permissible ambient temperature	
– Operation	5 to +35 °C Installation in living spaces or boiler rooms (standard ambient conditions)
– Storage and transport	–20 to +65 °C
Electronic temperature limiter setting (heating mode)	91 °C (cannot be altered)
DHW temperature setting range	10 to 60 °C (up to 70 °C with the Vitodens 300-W)
Setting range for heating curve	
Slope	0.2 to 3.5
Level	–13 to 40 K
RF module (integral)	
WiFi frequency band	2400 - 2483.5 MHz
Max. transmitting power	+ 17 dBm
Zigbee frequency band	2400 - 2483.5 MHz
Max. transmitting power	+ 10 dBm
Supply voltage	24 V =
Power consumption	4 W

9.3 Accessories for control unit

Vitotrol 100, type UTA

Part no. 7170149

Room thermostat

- With switching output (two-point output)
- With analogue time switch
- With adjustable individual day program
- Standard switching times are factory-set (individually programmable)
- Shortest switching interval 15 minutes

The Vitotrol 100 is installed in the main living room on an internal wall opposite radiators, although never inside shelving units, in recesses, or immediately by a door or heat source (e.g. direct sunlight, fireplace, TV set, etc.).

Control unit connection:

3-core cable with a cross-section of 1.5 mm² (no green/yellow wire) for 230 V~.

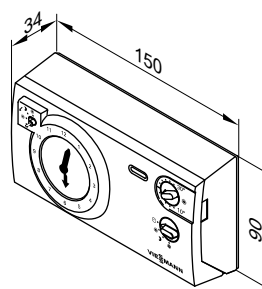

Specification

Rated voltage	230 V/50 Hz
Rated breaking capacity of the contact	6(1) A 250 V~
IP rating	IP 20 to EN 60529 Ensure through design/installation
Permissible ambient temperature	
– Operation	0 to +40 °C
– Storage and transport	–20 to +60 °C
Set value setting range for standard mode and reduced mode	10 to 30 °C
Set room temperature in standby mode	6 °C

Control unit (cont.)

Vitotrol 100, type UTDB

Part no. Z007691

Room temperature controller

- With switching output (two-point output)
- With digital time switch
- With individual day and seven-day program
- Operation with user prompts:
 - 3 preselected time programs, individually adjustable
 - Constant manual mode with adjustable set room temperature
 - Frost protection mode
 - Holiday program
- With selector keys for party and economy mode

Installation in the main living room on an internal wall opposite radiators. Never install inside shelving units, in recesses, or immediately by a door or heat source (e.g. direct sunlight, fireplace, TV set, etc.). Operation independent of mains power supply (two 1.5 V round alkaline cells, type LR6/AA, battery life approx. 1.5 years).

Control unit connection:

2-core cable with a cross-section of 0.75 mm² for 230 V~.

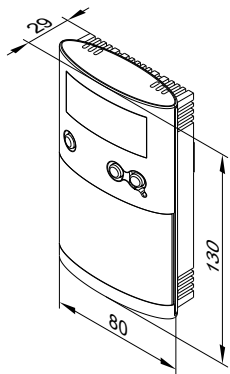

Specification

Rated voltage	3 V– Battery LR6/AA
Rated breaking capacity of the floating contact	
– max.	6(1) A, 230 V~
– min.	1 mA, 5 V–
IP rating	IP 20 to EN 60529 Ensure through design/installation
Function type	RS type 1B to EN 60730-1
Permissible ambient temperature	
– Operation	0 to +40 °C
– Storage and transport	–25 to +65 °C
Setting range	
– Comfort temperature	10 to 40 °C
– Setback temperature	10 to 40 °C
– Frost protection temperature	5 °C
Power reserve during battery change	3 min

Vitotrol 100, type UTDB-RF

Part no. Z007692

Room temperature controller with integral wireless transmitter and receiver

- With digital time switch
- With individual day and seven-day program
- Operation with user prompts:
 - 3 preselected time programs, individually adjustable
 - Constant manual mode with adjustable set room temperature
 - Frost protection mode
 - Holiday program
- With selector keys for party and economy mode

Installation in the main living room on an internal wall opposite radiators. Never install inside shelving units, in recesses, or immediately by a door or heat source (e.g. direct sunlight, fireplace, TV set, etc.). Room temperature controller operation independent of mains power supply (two 1.5 V round alkaline cells, type LR6/AA, battery life approx. 1.5 years).

Receiver with relay state indication.

Connection of the receiver to the control unit (subject to control unit type):

- 4-core cable with a cross-section of 1.5 mm² for 230 V~ or
- 3-core cable without green/yellow wire for 230 V~ or
- 2-core lead with a cross-section of 0.75 mm² for LV for the connection to the control unit, plus an additional 2-core cable for the 230 V~ power supply

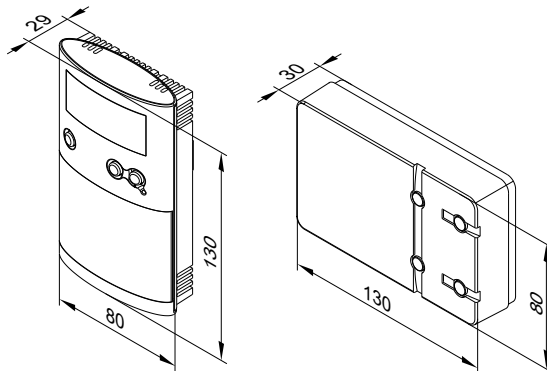

Control unit (cont.)

Specification, room temperature controller

Rated voltage	3 V–
Transmission frequency	868 MHz
Transmission	< 10 mW
Range	approx. 25 to 30 m inside buildings, subject to construction
IP rating	IP 20 to EN 60529 Ensure through design/installation
Function type	RS type 1B to EN 60730-1
Permissible ambient temperature	
– Operation	0 to +40 °C
– Storage and transport	–25 to +65 °C
Setting range	
– Comfort temperature	10 to 40 °C
– Setback temperature	10 to 40 °C
– Frost protection temperature	5 °C
Power reserve during battery change	3 min

Specification, receiver

Operating voltage	230 V~± 10 % 50 Hz
Rated breaking capacity of the floating contact	
– max.	6(1) A, 230 V~
– min.	1 mA, 5 V–
IP rating	IP 20 to EN 60529 Ensure through design/installation
Safety category	II to EN 60730-1 subject to correct installation
Permissible ambient temperature	
– Operation	0 to +40 °C
– Storage and transport	–25 to +65 °C

Vitotrol 200-E

Part no. Z017415

- PlusBus subscriber
- Max. 2 Vitotrol 200-E can be connected to a heat generator control as a PlusBus subscriber.
- Up to 4 heating circuits can be controlled with a Vitotrol 200-E. Alternatively, a Vitotrol 200-E can be assigned to a heating circuit. A heating circuit cannot be controlled by more than one remote control.

Displays

- Room temperature
- Outside temperature
- Operating condition

Settings

- Set room temperature for standard room temperature, comfort room temperature and reduced room temperature
- Set DHW temperature
- Switching times for heating circuits and DHW heating, plus further settings via plain text menu on the display
- Integral room temperature sensor for room temperature hook-up (only for one heating circuit with mixer)

Quick select function for:

- Comfort mode
- One-off cylinder heat-up
- Holiday program
- "Holiday at home"

Installation location

- Weather-compensated operation:
Installation anywhere in the building
- Room temperature hook-up:
The integral room temperature sensor captures the room temperature and effects any necessary correction of the flow temperature.

The captured room temperature depends on the installation site:

- Installation only in enclosed buildings
- Not next to windows or doors
- Not between shelves, in recesses, etc.
- Not near heat sources (direct insolation, fireplace, TV set, etc.)

Connection

- 2-core lead, length max. 50 m (even if connecting several remote control units)
- Never route this cable immediately next to 230/400 V cables.
- Extra low voltage (ELV) plug included in standard delivery

Specification

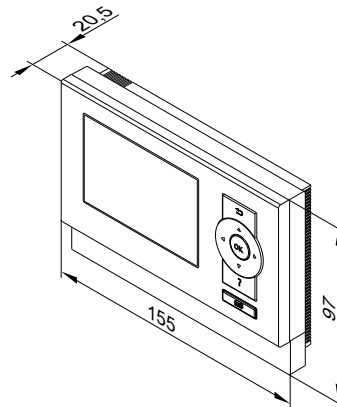

Vitotrol 200-E

Power supply		Via PlusBus
Voltage	V	28
Current	mA	25
Protection class		⚡
Permissible ambient temperature		
– Operation	°C	0 to +40
– Storage and transport	°C	–20 to +65 °C

Control unit (cont.)

Outside temperature sensor

Part no. ZK04306

Installation location:

- North or north-west facing wall of the building
- 2 to 2.5 m above the ground; for multi storey buildings in the upper half of the second floor

Connection:

- 2-core lead, length up to 35 m with a cross-section of 1.5 mm² (copper)
- Never route this cable immediately next to 230/400 V cables.

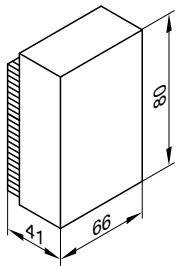

Specification

IP rating	IP 43 to EN 60529; ensure through design/installation.
Sensor type	Viessmann NTC 10 kΩ at 25 °C
Permissible ambient temperature during operation, storage and transport	-40 to +70 °C

Room temperature sensor

Part no. 7438537

Separate room temperature sensor as supplement to the Vitotrol 200-E; to be used if the Vitotrol 200-E cannot be installed inside the main living room or in a suitable position for temperature capture and adjustment.

Installation in the main living room on an internal wall opposite radiators. Never install inside shelving units, in recesses, or immediately by a door or heat source, e.g. direct sunlight, fireplace or TV set.

Connect the room temperature sensor to the Vitotrol 200-E.

Connection:

- 2-core lead with a cross-section of 1.5 mm² (copper)
- Max. lead length from the remote control: 30 m
- Never route this cable immediately next to 230/400 V cables.

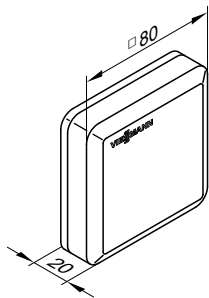

Specification

Protection class	III
IP rating	IP 30 to EN 60529; ensure through design/installation.
Sensor type	Viessmann NTC 10 kΩ at 25 °C
Permissible ambient temperature	
– Operation	0 to +40 °C
– Storage and transport	-20 to +65 °C

Immersion temperature sensor

Part no. ZK04032

To capture the low loss header temperature

Specification

Lead length	3.75 m, fully wired
IP rating	IP 32 to EN 60529; ensure through design/installation.
Sensor type	Viessmann NTC 10 kΩ at 25 °C
Permissible ambient temperature	
– Operation	0 to +90 °C
– Storage and transport	-20 to +70 °C

Control unit (cont.)

Cylinder temperature sensor

Part no. ZK04671

For capturing the DHW temperature in the on-site DHW cylinder

Specification

Lead length	3.75 m, fully wired
IP rating	IP 32
Sensor type	Viessmann NTC 10 kΩ at 25 °C
Permissible ambient temperature	
– Operation	0 to +90 °C
– Storage and transport	–20 to +70 °C

Contact thermostat

Part no. ZK04647

Can be used as a maximum temperature limiter for underfloor heating systems (only in conjunction with metal pipes).

The temperature limiter is fitted to the heating flow. If the flow temperature is too high, the temperature limiter switches off the heat generator.

Specification

Lead length	1.5 m
Setting range	30 to 80 °C
Switching differential	6.5 K ±2.5 K
Breaking capacity	6(1.5) A, 250 V~
Setting scale	Inside the enclosure
Protection rating to EN 60529	IP 41

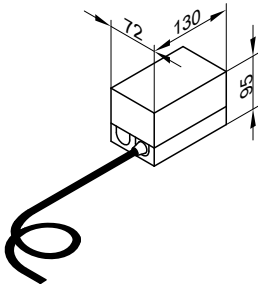

Information on PlusBus subscribers

Only the following PlusBus subscribers can be connected to the control unit:

- 3 EM-M1 or EM-MX extensions (ADIO electronics module)
- 2 Vitotrol 200-E
- 3 EM-EA1 extensions (DIO electronics module)

- 1 EM-S1 extension (ADIO or SDIO/SM1A electronics module)
- 1 EM-P1 extension (ADIO electronics module)

The max. total length of the PlusBus lead is 50 m.
With an unscreened lead, 2-core, 0.34 mm².

EM-MX mixer extension kit with integral mixer motor

Part no. Z017409

PlusBus subscriber

Components:

- Mixer PCB (ADIO electronics module) with mixer motor for Viessmann mixer DN 20 to DN 50 and R ½ to R 1¼
- Flow temperature sensor (contact temperature sensor) with connecting lead and plug
- Plug for connecting the heating circuit pump
- Power cable (3.0 m long) with plug
- PlusBus connecting lead (3.0 m long) with plug
- Option to connect immersion temperature sensor low loss header (separate accessory)

The mixer motor is mounted directly onto the Viessmann mixer DN 20 to DN 50 and R ½ to R 1¼.

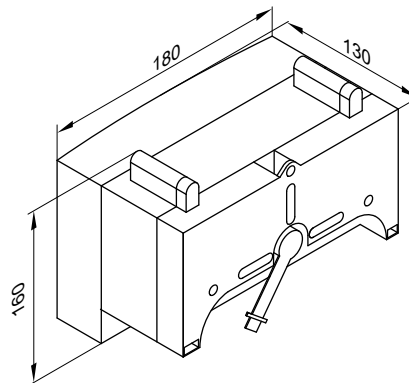
Mixer PCB with mixer motor

Control unit (cont.)

Specification - Mixer PCB with mixer motor

Rated voltage	230 V~
Rated frequency	50 Hz
Rated current	2 A
Power consumption	5.5 W
IP rating	IP 20D to EN 60529; ensure through design/installation.
Protection class	I
Permissible ambient temperature	
– Operation	0 to +40 °C
– Storage and transport	–20 to +65 °C
Rated relay output breaking capacity	
– Heating circuit pump [20]	1 A, 230 V~
– Mixer motor [52]	0.1 A, 230 V~
Torque	3 Nm
Required runtime of the mixer motor for 90° <	Approx. 120 s

Flow temperature sensor (contact temperature sensor)

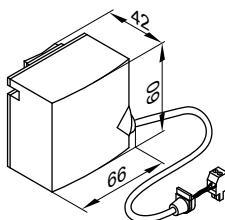

Secured with a tie.

Flow temperature sensor specification

Lead length	2.0 m, fully wired
IP rating	IP 32D to EN 60529; ensure through design/installation.
Sensor type	Viessmann NTC 10 kΩ at 25 °C
Permissible ambient temperature	
– Operation	0 to +120 °C
– Storage and transport	–20 to +70 °C

EM-M1 mixer extension kit for separate mixer motor

Part no. Z017410

PlusBus subscriber

For connecting a separate mixer motor

Components:

- Mixer PCB (ADIO electronics module) for connecting a separate mixer motor
- Flow temperature sensor (contact temperature sensor) with connecting lead and plug
- Plug for connecting the heating circuit pump and the mixer motor
- Power cable (3.0 m long) with plug
- PlusBus connecting lead (3.0 m long) with plug
- Option to connect immersion temperature sensor low loss header (separate accessory)

Mixer PCB

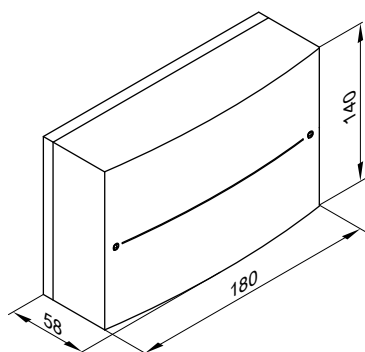

Mixer PCB specification

Rated voltage	230 V~
Rated frequency	50 Hz
Rated current	2 A
Power consumption	1.5 W

IP rating	IP 20D to EN 60529; ensure through design/installation.
Protection class	I
Permissible ambient temperature	
– Operation	0 to +40 °C
– Storage and transport	–20 to +65 °C
Rated relay output breaking capacity	
– Heating circuit pump [20]	1 A, 230 V~
– Mixer motor [52]	0.1 A, 230 V~
Required runtime of the mixer motor for 90° <	Approx. 120 s

Flow temperature sensor (contact temperature sensor)

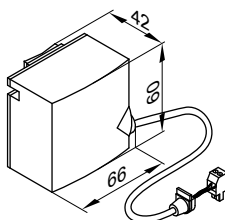

Secured with a tie.

Flow temperature sensor specification

Lead length	5.8 m, fully wired
IP rating	IP 32D to EN 60529; ensure through design/installation.
Sensor type	Viessmann NTC 10 kΩ at 25 °C
Permissible ambient temperature	
– Operation	0 to +120 °C
– Storage and transport	–20 to +70 °C

EM-MX mixer extension kit for Divicon heating circuit distribution

Part no. Z017414

PlusBus subscriber

Control unit (cont.)

Components:

- Mixer PCB (ADIO electronics module) with mixer motor for Divicon heating circuit distribution
- Flow temperature sensor (contact temperature sensor) with connecting lead and plug
- Plug for connecting the heating circuit pump
- Power cable (3.0 m long) with plug
- PlusBus connecting lead (3.0 m long) with plug
- Option to connect immersion temperature sensor low loss header (separate accessory)

The mixer motor is mounted directly onto the Viessmann mixer of the Divicon heating circuit distributor.

Mixer PCB with mixer motor

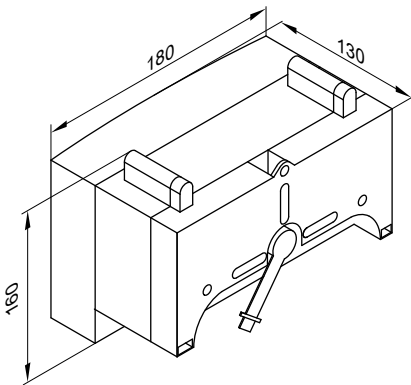

Specification - Mixer PCB with mixer motor

Rated voltage	230 V~
Rated frequency	50 Hz
Rated current	2 A
Power consumption	5.5 W
IP rating	IP 20D to EN 60529; ensure through design/installation.
Protection class	I
Permissible ambient temperature	
– Operation	0 to +40 °C
– Storage and transport	–20 to +65 °C
Rated relay output breaking capacity	
– Heating circuit pump [20]	1 A, 230 V~
– Mixer motor [52]	0.1 A, 230 V~
Torque	3 Nm
Required runtime of the mixer motor for 90° <	Approx. 120 s

EM-P1 extension

Part no. Z017411

Function extension to control a heating circuit pump and/or DHW circulation pump depending on the hydraulics of the heating system

- Controlling a heating circuit pump for a heating circuit without mixer (heating circuit 1)
- Controlling a DHW circulation pump

In an enclosure for wall mounting
PlusBus subscriber

Components:

- ADIO electronics module
- Plug for connecting the heating circuit pump
- Power cable (3.0 m long) with plug

Flow temperature sensor (contact temperature sensor)

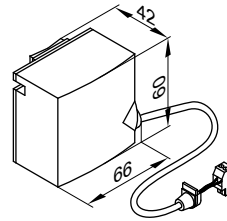

Secured with a tie.

Flow temperature sensor specification

Lead length	2.0 m, fully wired
IP rating	IP 32D to EN 60529; ensure through design/installation.
Sensor type	Viessmann NTC 10 kΩ at 25 °C
Permissible ambient temperature	
– Operation	0 to +120 °C
– Storage and transport	–20 to +70 °C

Control unit (cont.)

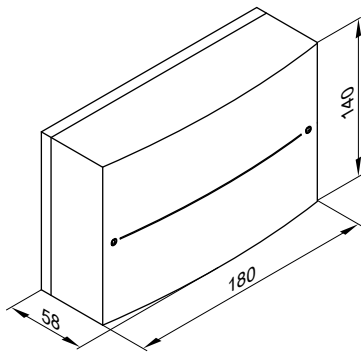

Specification

Rated voltage	230 V~
Rated frequency	50 Hz
Rated current	2 A
Power consumption	1.5 W
Rated relay output breaking capacity	1 A, 230 V~
Protection class	I
IP rating	IP 20D to EN 60529; ensure through design/installation.
Permissible ambient temperature	
– Operation	0 to +40 °C
	Installation in living spaces or boiler rooms (standard ambient conditions)
– Storage and transport	–20 to +65 °C

Solar control units

SDIO/SM1A electronics module

- Integrated in the DHW cylinder and Solar-Divicon.
- Compatible with Viessmann control units with PlusBus or KM-BUS communication
- Automatic differentiation between PlusBus and KM-BUS subscribers

Functions

- Control and display via the heat generator control unit
- Switching the solar circuit pump
- Solar circuit pump speed control via PWM signal
Only use solar circuit pumps with PWM input.
- Suppression of DHW cylinder reheating by the heat generator subject to solar yield
- Collector safety shutdown
- Electronic temperature limitation in the DHW cylinder
- Switching of a transfer pump for the DHW cylinder
- Frost protection function
- General function overview: See chapter "Functions".

Design

- PCB
- Terminals:
 - 4 sensors
 - Solar circuit pump
 - KM-BUS/PlusBus
 - Power supply (on-site ON/OFF switch)
- PWM output for switching the solar circuit pump
- 1 relay for switching one pump or one valve

Collector temperature sensor

Delivered separately for connection inside the appliance.
On-site extension of the connecting lead:

- 2-core lead, length up to 60 m with a cross-section of 1.5 mm² (copper)
- Never route this lead immediately next to 230/400 V cables

Specification – collector temperature sensor

Lead length	2.5 m
IP rating	IP 32 to EN 60529; ensure through design/installation.
Sensor type	Viessmann NTC 20 kΩ at 25 °C
Permissible ambient temperature	
– Operation	–20 to +200 °C
– Storage and transport	–20 to +70 °C

Cylinder temperature sensor

The sensor is connected inside the control unit.

Specification – cylinder temperature sensor

IP rating	IP 32 to EN 60529; ensure through design/installation.
Sensor type	Viessmann NTC 10 kΩ at 25 °C
Permissible ambient temperature	
– Operation	0 to +90 °C
– Storage and transport	–20 to +70 °C

Specification – SDIO/SM1A electronics module

Rated voltage	230 V ~
Rated frequency	50 Hz
Rated current	2 A
Power consumption	1.5 W
Protection class	I
IP rating	IP 20D to EN 60529; ensure through design/installation.
Permissible ambient temperature	
– Operation	0 to +35 °C, use in the living space or boiler room (standard ambient conditions)
– Storage and transport	–20 to +65 °C
Rated relay output breaking capacity	
– Semi-conductor relay 1	1 (1) A, 230 V~
– Relay 2	1 (1) A, 230 V~
– Total	Max. 2 A

EM-S1 extension

Part no. Z017413

- PlusBus subscriber
- Function extension inside enclosure for wall mounting

Functions

- Control and display via the heat generator control unit
- Switching the solar circuit pump
- Solar circuit pump speed control via PWM signal
Only use solar circuit pumps with PWM input.
- Suppression of DHW cylinder reheating by the heat generator subject to solar yield
- Collector safety shutdown
- Electronic temperature limitation in the DHW cylinder
- Switching of a transfer pump for the DHW cylinder
- Frost protection function
- General function overview: See chapter "Functions".

Control unit (cont.)

Design

- PCB
- Terminals for:
 - 3 sensors
 - Solar circuit pump
 - PlusBus
 - Power supply
- PWM output for switching the solar circuit pump
- 1 relay for switching a transfer pump

Collector temperature sensor

For connection inside the appliance

On-site extension of the connecting lead:

- 2-core lead, length up to 60 m with a cross-section of 1.5 mm² (copper)
- Never route this lead immediately next to 230/400 V cables.

Specification – collector temperature sensor

Lead length	2.5 m
IP rating	IP 32 to EN 60529; ensure through design/installation.
Sensor type	Viessmann NTC 20 kΩ at 25 °C
Permissible ambient temperature	
– Operation	–20 to +200 °C
– Storage and transport	–20 to +70 °C

Cylinder temperature sensor

For connection inside the appliance

On-site extension of the connecting lead:

- 2-core lead, length up to 60 m with a cross-section of 1.5 mm² (copper)
- Never route this lead immediately next to 230/400 V cables.

Specification – cylinder temperature sensor

Lead length	3.75 m
IP rating	IP 32 to EN 60529; ensure through design/installation.
Sensor type	Viessmann NTC 10 kΩ at 25 °C
Permissible ambient temperature	
– Operation	0 to +90 °C
– Storage and transport	–20 to +70 °C

For systems with Viessmann DHW cylinders, the cylinder temperature sensor is installed in the threaded elbow in the heating water return (standard delivery or accessory for the respective DHW cylinder).

Specification – EM-S1 extension

Rated voltage	230 V~
Rated frequency	50 Hz
Rated current	2 A
Power consumption	1.5 W
Protection class	I
IP rating	IP 20 to EN 60529, ensure through design/installation.
Function type	Type 1B to EN 60730-1
Permissible ambient temperature	
– Operation	0 to +40 °C, use in the living space or boiler room (standard ambient conditions)
– Storage and transport	–20 to +65 °C
Rated relay output breaking capacity	1 A, 230 V~

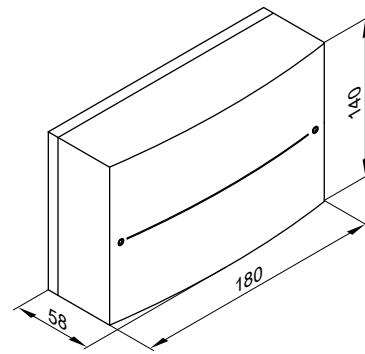

Delivered condition

- EM-S1 extension
- Cylinder temperature sensor
- Collector temperature sensor

Functions

Cylinder temperature limit

The solar circuit pump will be switched OFF if the set cylinder temperature is exceeded.

Collector emergency stop

In order to protect the system components, the solar circuit pump is switched off if the adjustable collector limit temperature is exceeded. In the Vitosol-FM and 300-TM switching collectors, the collector temperature limit can be set to 145 °C. To do so, please comply with the manufacturer system pressure specification. This enables solar circuit pump operation even when the system is shut down.

Ensure the following:

- The components in the solar circuit flow line must be designed for a temperature of 145 °C.
- The return line temperature must not exceed 120 °C.

Minimum collector temperature limit

If the actual temperature falls below the minimum collector temperature, the solar circuit pump is shut down.

Frost protection function

Viessmann collectors are filled with Viessmann heat transfer medium. This function does not have to be activated.

Activate only when using water as the heat transfer medium.

With a collector temperature below +5 °C, the solar circuit pump will be started to avoid damage to the collectors. The pump is stopped when a temperature of +7 °C is reached.

Heat statement

When determining thermal yields, the difference between the collector and cylinder temperature, the set throughput, the type of heat transfer medium and the operating time of the solar circuit pump are taken into account.

Reheating suppression

DHW cylinder reheating by the boiler is suppressed in 2 stages.

During solar heating of the DHW cylinder, the set cylinder temperature is reduced. Suppression remains active for a certain time after the solar circuit pump is switched off.

If solar heating is uninterrupted (> 2 h), reheating by the boiler only occurs if the temperature falls below the 3rd set DHW temperature, as set at the boiler control unit (in parameter "1394.0") (setting range 10 to 95 °C). This value must be **below** the 1st set DHW temperature.

If the solar thermal system is unable to maintain this set value, the DHW cylinder is heated by the boiler (solar circuit pump running).

Control unit (cont.)

Auxiliary function for DHW heating

In solar thermal systems with DHW storage, we recommend heating the preheating cylinder and the preheating stage in dual mode DHW cylinders to ≥ 60 °C once a day (regardless of the cylinder volume). Enabling of the auxiliary function for DHW heating must be programmed at the boiler control unit. The solar preheat stage can be heated up at selectable times.

Relay kick

If the pumps and valves have been switched off for 24 hours, they are started for approx. 10 s to prevent them seizing up.

Reduction of stagnation time

If there is an excess of solar energy, the speed of the solar circuit pump is reduced before the maximum cylinder temperature is reached. This causes an increase in the differential between collector temperature and cylinder temperature. The heat transfer to the DHW cylinder is reduced, which delays stagnation.

EM-EA1 extension

Part no. Z017412

- PlusBus subscriber
- Enclosure for wall mounting

Functions

Note

Only one function can be connected to each EM-EA1 extension (DIO electronics module).

■ 230 V fault message input and fault message output (potential-free) without system blocking

Fault message input: If a voltage of 230 V is present at digital input contact 43-1, fault message is active. Fault message output 66 active.

■ External LPG valve

Output 43-L is active if the burner control unit opens the external LPG valve.

■ Extractor hood: External extractor interlock

An extractor can be switched off. Output 66 switches from \bar{O} to S and thereby switches the extractor hood off when the burner control unit starts the burner.

■ Changing operating modes

Demand to all available heating circuits simultaneously, as long as contact remains closed. With the set room temperature of each individual heating circuit:

- D11 Reduced room temperature
- D12 Standard room temperature
- D13 Comfort room temperature

■ Fault message input 24 V and system blocking, e.g. condensate removal pump

If contact D11 is closed, the heat generator is blocked. Output 66 is switched over. Fault message F.104 appears. E.g. block burner if fault is present at condensate removal pump.

Note

If only the fault message output is to be used, set e.g. the "fault message input... and fault message output" functions.

■ Fault message input 230 V and system blocking

If a voltage of 230 V is present at digital input contact 43-1, the heat generator is blocked. Output 66 is switched over. Fault message F.104 appears.

■ External demand (digital)

If a voltage of 230 V is present at digital input contact 43-1, a demand is sent to the heat generator with an adjustable set flow temperature (parameter 528.0) and a set speed for the primary circuit pump (parameter 1100.2).

■ External blocking

If a voltage of 230 V is present at digital input contact 43-1, the heat generator is blocked. Message info I.57 is displayed.

Components:

- DIO electronics module
- Plug for connecting the functions
- Power cable (3.0 m long) with plug
- PlusBus connecting lead (3.0 m long) with plug

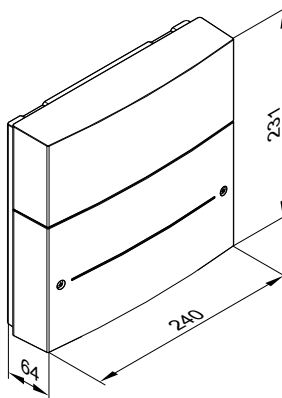

Specification

Rated voltage	230 V~
Rated frequency	50 Hz
Rated current	2 A
Power consumption	2.8 W
Rated breaking capacity output 66 (potential-free)	1 A 230 V~
Output 43 rated breaking capacity	1 A 230 V~
Protection class	I
IP rating	IP 20D to EN 60529; ensure through design/installation.
Permissible ambient temperature	
– Operation	0 to +40 °C Installation in living spaces or boiler rooms (standard ambient conditions)
– Storage and transport	–20 to +60 °C

Demand to digital input DI to DI3

External contacts must be potential-free. When connecting, observe the requirements of protection class II, i.e. 5.0 mm air and creep path and 2.0 mm insulation thickness to live parts.

10.1 Regulations / Directives

Regulations and directives

We, Viessmann Werke GmbH & Co. KG, declare that the Vitodens gas condensing boilers have been tested and approved in accordance with the currently applicable directives/regulations, standards and technical rules.

Observe all engineering standards of the building authorities and statutory requirements applicable to the installation and operation of this system.

Installation, gas and flue gas connections, commissioning, electrical connections and general service/maintenance may only be carried out by a registered contractor.

The installation of a condensing boiler must be reported to and approved by the relevant gas supply utility.

In some regions, permits may be required for the flue system and condensate drain into the public sewage system.

The local flue gas inspector and water authorities must be informed prior to commencing the installation.

We recommend that maintenance and cleaning procedures are performed annually. As part of the maintenance procedure, check the correct function of the entire system. Any faults that occur must be rectified.

Condensing boilers must only be operated with specially designed, tested and approved flues.

Only an authorised contractor may convert this boiler for use in countries other than those stated on the type plate. That contractor must also arrange approval in accordance with the statutes of the relevant country.

Keyword index

A		M	
Accessories		Mixer extension	
– For installation.....	62	– Integral mixer motor.....	145
Accessories for control unit.....	141	– Integrated mixer motor.....	146
Anti-corrosion agents.....	134	– Separate mixer motor.....	146
Assembly kit.....	78, 82	Mixer extension kit	
		– Integral mixer motor.....	145
		– Separate mixer motor.....	146
		Mounting frame.....	66
C		N	
Cables.....	96	Neutralisation.....	133
Carbon monoxide.....	94, 95	Neutralising system.....	134
Cold water connection.....	19		
CO limiter.....	94, 95	O	
Comfort function.....	13	Open flue operation.....	94
Condensate.....	133	Outlet temperature sensor.....	140
Condensate connection.....	132	Outside temperature sensor.....	144
Connections.....	19		
Contact thermostat.....	145	P	
Control unit.....	137	Plumbing wall installation.....	103
Cylinder sizing.....	126	Pre-installation.....	97
Cylinder temperature sensor.....	140	Programming unit.....	137, 138
		Protection.....	95
D		R	
Decision making aids for DHW heating.....	125	Replacing third party boilers.....	105
DHW circulation.....	129, 131	Room sealed operation.....	94
DHW connection.....	19, 127, 130	Room temperature controller.....	142
DHW cylinder below the boiler.....	48	Room temperature sensor.....	144
DHW cylinders.....	126	Room thermostat.....	141, 142
DHW cylinders adjacent to the boiler.....	51		
DHW heating.....	125	S	
Drain outlet kit.....	69	Safety assembly to DIN 1988.....	129, 131
Draw-off rate.....	13	Safety equipment.....	134
Dual mode DHW cylinder.....	58	Safety valve.....	19, 128, 134
		Safety zone, electrical.....	96
		Shock arrestor.....	128
		Siting conditions.....	94
		Slope.....	140
		Solar extension.....	148
		– Specification.....	149
		Specification	
		– Control unit.....	141
		– Extension EM-S1.....	149
		Standby instantaneous water heater.....	13
		Sub-mounting kit.....	65, 73, 102
		– Vitodens 222-W.....	112
		System design.....	134
E		T	
Electrical connection.....	96	Temperature sensor	
Electrical safety zone.....	96	– Room temperature sensor.....	144
EM-EA1 extension.....	150	Temperature sensors	
EM-P1 extension.....	147	– Flow temperature sensor.....	140
EM-S1 extension.....	148	– Outside temperature sensor.....	144
EnEV.....	139	Thermally activated safety shut-off valve.....	97
Expansion vessel.....	135	Thermostat	
Extension kit, mixer		– Contact temperature.....	145
– Integrated mixer motor.....	146		
F			
Flow temperature sensor.....	140		
Frost protection function.....	140		
G			
Gas connection.....	19, 96		
H			
Headers, low loss.....	136		
Heating curves.....	140		
Heating flow.....	19		
Heating return.....	19		
Hydraulic connection.....	134		
I			
Installation.....	97		
Installation in unfinished buildings.....	97		
Installation room.....	94		
Instantaneous water heater.....	127		
Interlock circuit.....	94		
Interlock switch.....	96		
L			
Level.....	140		
Loading cylinder.....	23, 32, 125, 131		
Low loss header.....	136		
Low water indicator.....	135		

Keyword index

V

Vitocell 100.....	48
Vitocell 100-W.....	51, 58
Vitocell 100-W adjacent to the boiler	
– Pressure drop on the DHW side.....	54, 60
Vitocell 100-W below the boiler	
– Pressure drop on the DHW side.....	50
Vitocell 200-W.....	55
Vitocell 300-W adjacent to the boiler	
– Pressure drop on the DHW side.....	56
Vitotrol	
– 200-E.....	143
Vitotrol 100	
– UTA.....	141
– UTDB.....	142
– UTDB-RF.....	142

W

Weather-compensated control	
– Frost protection function.....	140
Weather-compensated control unit	
– Functions.....	139
– Programming unit.....	137, 138
Wet room.....	95





Subject to technical modifications.

Viessmann Werke GmbH & Co. KG
D-35107 Allendorf
Telephone: +49 6452 70-0
Fax: +49 6452 70-2780
www.viessmann.com

Viessmann Limited
Hortonwood 30, Telford
Shropshire, TF1 7YP, GB
Telephone: +44 1952 675000
Fax: +44 1952 675040
E-mail: info-uk@viessmann.com

5853906