

Installation Instructions

for use by heating contractor



Burner Assembly

for Vitodens 200-W, WB2B 19, 26, 35, B2HA 19, 28, 35
Vitodens 222-F, B2TA 19, 35

Safety and Installation Requirements

Please ensure that these instructions are read and understood before starting any service work. Failure to comply with these instructions may cause product/property damage, severe personal injury and/or loss of life.

Working on the equipment

The installation, adjustment, service and maintenance of this product must be performed by a licensed professional heating contractor who is qualified and experienced in the installation, service, and maintenance of hot water boilers. There are no user serviceable parts on the boiler, burner or control.

Ensure that main power to the equipment being serviced is off.

Ensure that the main fuel supply valve to the boiler is closed.

Take precautions to avoid accidental activation of power or fuel during service work.

Do not perform service work on any component part without ensuring safe operation of the heating system. When replacing parts, use original Viessmann or Viessmann approved replacement parts.



Refer to the Installation and Start-up/Service Instructions applicable to this boiler.

Parts List

Part Number	Description
7836177	Burner Gasket, 187x5.5 mm
7826516	Ignition Electrode with Gasket
7826519	Burner Mounting Flange Assembly
7827024	Gasket (Electrode Block)
7827025	Gasket (Ignition Electrode)
7827957	Ignition Transformer BW12126-00
7827958	Venturi Extension with Gasket
7828346	Combustion Chamber Door Refractory
7831485	Gas Connection Pipe
7831487	Radial Fan NRG118 with Gaskets
7834234	Ionization Electrode with Gasket
7829796	Gasket (Radial Fan)
7826513	Burner Tube

Accessing the Burner Assembly

1. With the electrical power and fuel supply off, open the control cover and switch the ON/OFF "ⓐ" boiler control switch to OFF.
2. Remove the front enclosure panel.



For more details refer to the Installation and Start-up/Service Instructions applicable to this boiler.

Replacing the Electrodes and Transformer

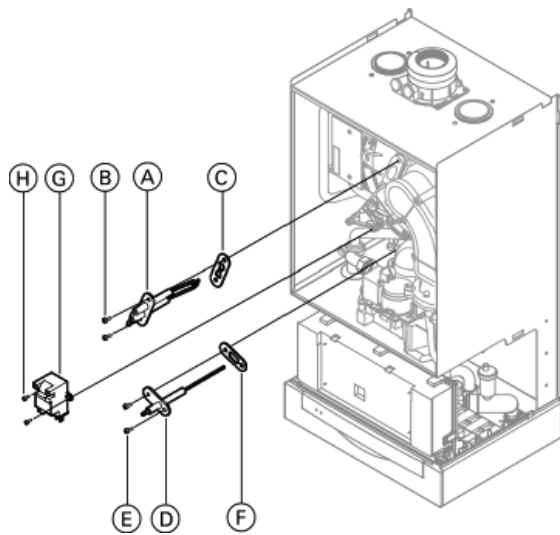

1. Disconnect the cables from the, ignition electrode (Ⓐ), ionization electrode (Ⓓ) and/or ignition transformer (Ⓖ).
2. To replace the following:
 - Remove two 4 mm Allen screws (Ⓑ) and remove ignition electrode (Ⓐ) and gasket (Ⓒ).
 - Remove two 4 mm Allen screws (Ⓔ) and remove ionization electrode (Ⓓ) and gasket (Ⓕ).
 - Remove two 4 mm Allen screws (Ⓗ) and remove ignition transformer (Ⓖ).



Refer to Start-up/Service Instructions to check and adjust ignition and ionization electrodes.

3. Replace parts as required and reassemble as per steps 2 and 1 respectively and torque screws.
4. See 'Reconnecting the Boiler' to place the boiler back in operation.

Legend

Tightening torque of fasteners:

- Ⓑ 40 lb.in. (4.5 Nm)
- Ⓔ 40 lb.in. (4.5 Nm)
- Ⓗ 13.2 lb.in. (1.5 Nm)

Replacing the Burner Assembly Components

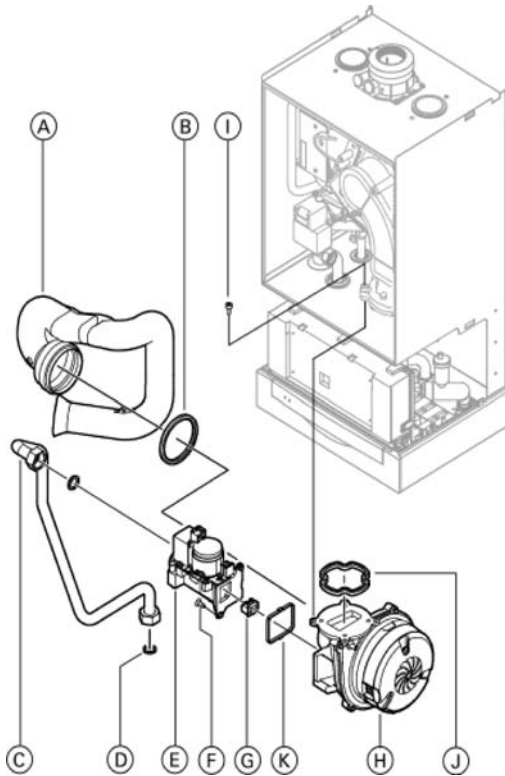

Legend

Tightening torque of fasteners:

Ⓒ 22 lb.in. (30 Nm)

Ⓕ 35 lb.in. (4 Nm)

Ⓘ 44 lb.in. (5 Nm)

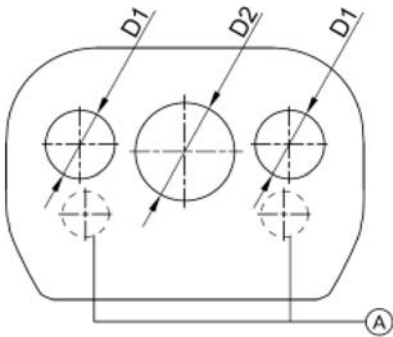

! WARNING

Gas leaks can lead to explosions. Check the gas pipe seals to ensure that there are no leaks.

1. Remove the Venturi extension (A) and gasket (B).
2. Loosen and remove the gas connection pipe (C) and two gaskets (D).
3. Remove the two 4 mm Allen screws (F) and remove gas valve (E). Inspect gas valve gasket (K) and replace if necessary.
4. Inspect and replace fixed gas orifice (G) if necessary. To remove use pliers.
Note: Refer to 'Identification of the Fixed Gas Orifice' Chart.
5. Replacement Gas Valve – Remove, using pliers, and discard shipping plug in replacement gas valve before installing orifice. Remove, using pliers, orifice out of gas valve being replaced and insert into new gas valve.
6. Remove two 5 mm Hex screws (I) to remove radial fan assembly (H) and gasket (J).

IMPORTANT

Use new gaskets and o-rings on all connections

7. Replace parts as required and reassemble as per steps 5 through 1 respectively and torque fasteners.
8. See 'Reconnecting the Boiler' to place the boiler back in operation.



Refer to Installation and Start-up/Service Instructions applicable to this boiler.

Identification of the Fixed Gas Orifice

Color	black
Stamped No. (A)	0 6
D1	3.20 mm
D2	4.20 mm

Replacing the Burner Assembly Components

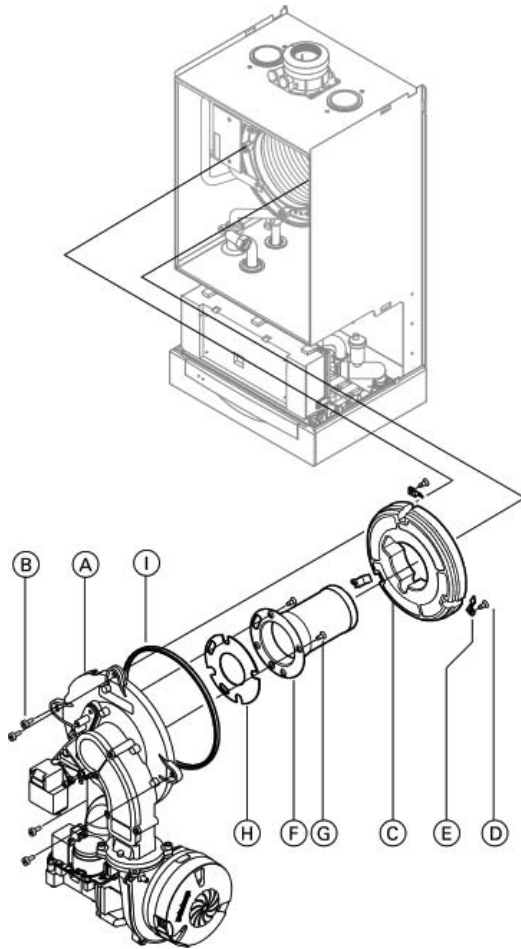

1. Disconnect all electrical connections and ground lead.
2. With gas pipe disconnected, remove the six Torx screws (T-30) (B) and remove the burner mounting flange assembly (A).

CAUTION

To avoid damage to the burner, do not lay burner on its cylindrical burner tube. Failure to heed this caution may cause damage to the burner tube, which may lead to improper operation.

3. Remove three 4 mm Allen screws (D) and three clips (E) and remove refractory (C).
4. Remove four Torx screws (T-25) (G) and remove burner tube (F) and gasket (H).
5. Inspect burner mounting flange assembly gasket (I) for damage. Replacing the gasket every 2 years is recommended.
6. Replace parts as required and reassemble as per steps 4 through 1 respectively and torque screws.
7. See 'Reconnecting the Boiler' to place the boiler back in operation.

Legend

Tightening torque of fasteners:

- (B) 79.7 lb.in. (9 Nm)
- (D) 44 lb.in. (5 Nm)
- (G) 26.5 lb.in. (3 Nm)

Reconnecting the Boiler

1. Install front enclosure panel.
2. Place the boiler back in operation.



For more details refer to the Installation and Service Instructions applicable to this boiler.

