

EN

All-round protection
for heating water

SorbOx®

SorbOx
by ELYSATOR™

Installation
Function
Operation
Service

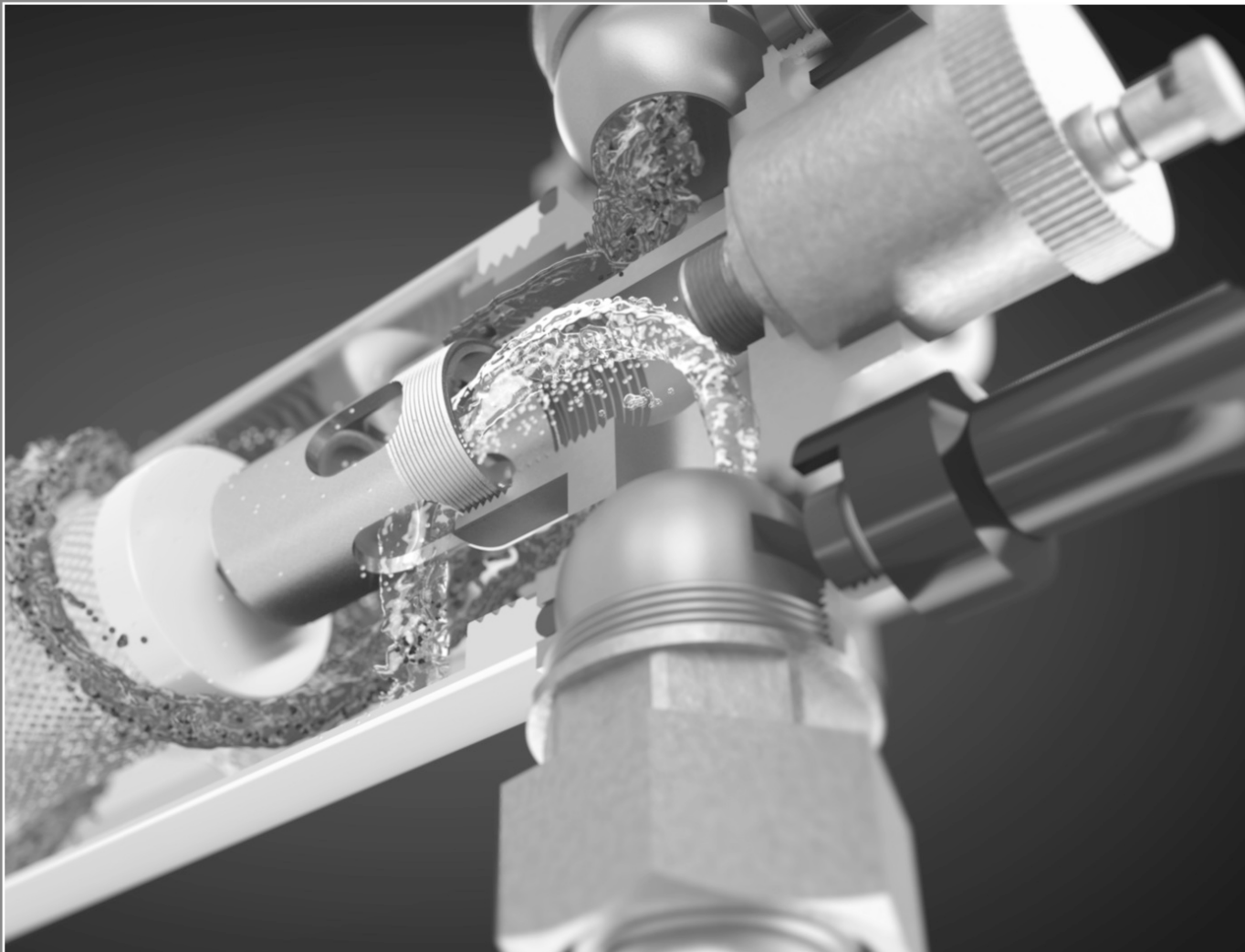

SorbOx® is the revolutionary water filter for energy efficient heating systems. It packs no less than 4 functions into a single device:

- Demineralization of heating water prevents limescale deposits
- Micro gas bubble separator removes oxygen and other gases from the circulating water
- Anode protection safeguards an optimum heat transfer
- Magnetic flow filter in the circulating water holds back sludge and rust particles

ELYSATOR 
engineering water

www.elysator.com

Content

| | |
|---|---|
| The problem: heating system corrosion | 4 |
| The solution: clean, safe heating water | 5 |
| Correct installation | 6 |
| Data and dimensions | 7 |
| Maintenance | 8 |

The problem

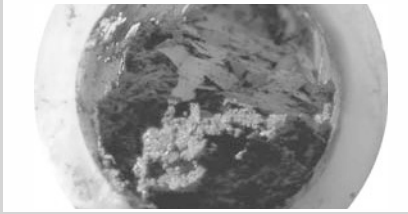

Sludge deposits

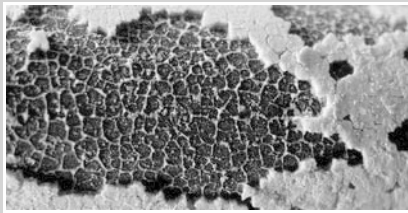

Limescale

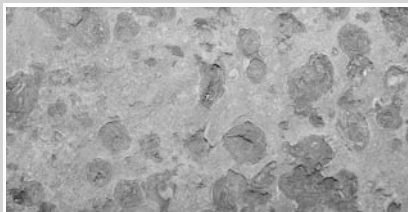

Rust

- Sludge in underfloor heating system pipework resulting from corrosion products
- Blocking of control valves and pumps
- Corrosion perforations in boilers
- Perforations resulting in water damage
- Flow noise through corrosion-related gassing
- Higher energy consumption through uneven heat distribution

In days gone by, underfloor heating systems were often installed using plastic pipes that were permeable to oxygen. By now, most manufacturers will produce underfloor heating pipes that are almost diffusion-proof. Nevertheless, valves, fittings, circulation pumps, control units, automatic air vent valves and faulty expansion vessels represent major sources for possible oxygen ingress. Oxygen diffused into the heating water, pH values that are too low and increased electrical conductivity of system water can result in corrosion and sludge deposits inside the heating system.

In the past, adding chemical corrosion inhibitors was the corrosion protection method of

choice. However, in many cases it was noticed that in gaps or beneath dirt or corrosion deposits there was no active protection. In other words, no lasting solution to the problem at hand. Furthermore, monitoring the correct dosing of inhibitors takes time and costs money. In the final analysis, the use of heat exchangers to separate the system into heating and boiler circuits only results in a separation of the problem into two parts without actually achieving active corrosion protection.

Advanced heating systems respond more sensitively to corrosion and the separating out of water constituents.

Rust, limescale and sludge deposits destroy advanced heating systems and cost plenty

Corrosion

relative to oxygen and salt content in heating water

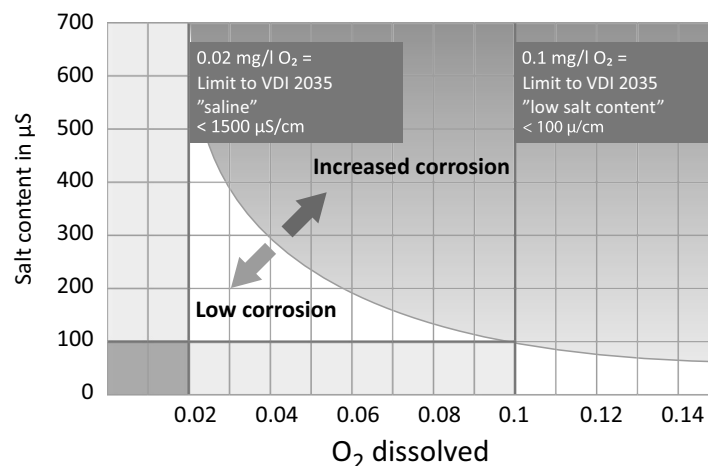

The solution

Clean, safe heating water

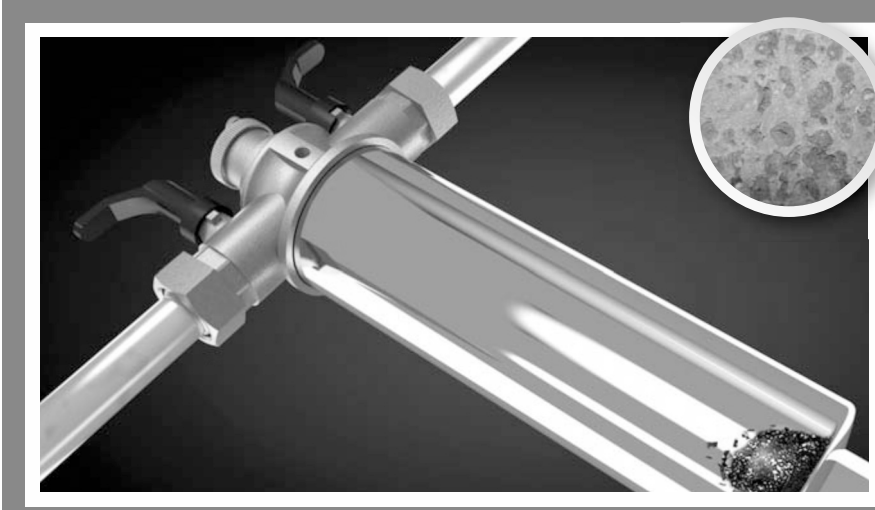

No rust

The SorbOx® filter separates rust and sludge from the water without becoming blocked.

Rust and sludge particles are held back by means of a strong magnet on the underside of the filter and gravity. Close valves for cleaning. Then simply undo the filter and flush.



No gases

Insert the ELYSATOR® anode unit for degassing.

The anode system removes corrosive and acidic gases through an electrochemical reaction using a sacrificial anode. Micro gas bubbles are separated, collected and removed through the venting network.

Option SorbOx® L



No limescale

Use the PUROTAP® cartridge for desalination. Within a few hours it absorbs all dissolved minerals in the circulating water.

This prevents the formation of limescale deposits, which also reduces the corrosion rate.

Correct installation

- Degassing
- Anode protection
- Anode protection

Installation in the main flow
 Installation in the main heating system flow (full flow rate) for maximum separation of micro gas bubbles. Circulating contamination is also filtered out via the flow.

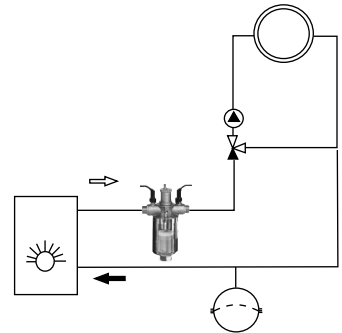

- Degassing
- Anode protection
- Anode protection

Installation in a system component (assembly)
 If the source of oxygen diffusion is known (e.g. underfloor heating assembly), then the SorbOx® can also be used in assembly circulation.

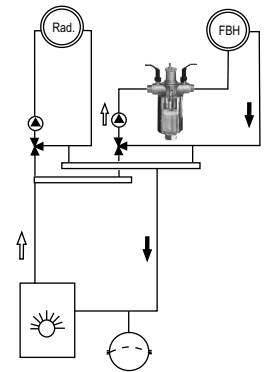

- Degassing
- Anode protection
- Anode protection

Installation in an ancillary circuit
 The SorbOx® can be installed in an ancillary circuit, for which a flow meter should be installed. The smaller the partial flow, the less effective the degassing and filter performance. However, water conditioning by means of a sacrificial anode is still effective down to a minimum flow rate of 2 l/min.

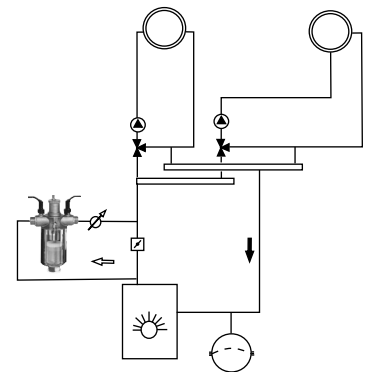

- Degassing
- Anode protection
- Anode protection

Installation in the main return
 The SorbOx® can be installed in the main return if the function of the sludge collector is given top priority. Water conditioning by the sacrificial anode is also effective in the return; however, there will then be hardly any separation of micro gas bubbles.

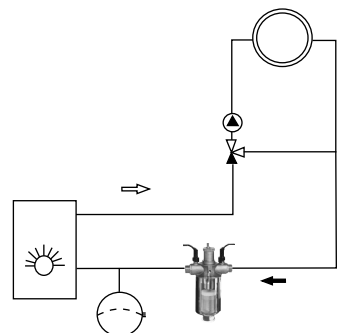

SorbOx® improves the efficiency and reliability of ecological advanced heating systems.

- Heat pump systems
- Condensing boilers
- Heating systems with solar backup
- Underfloor, wall and ceiling heating systems
- Heat recovery
- Regulated mechanical ventilation
- Green technology

Data and dimensions

SorbOx® S/SI (against rust, gases)

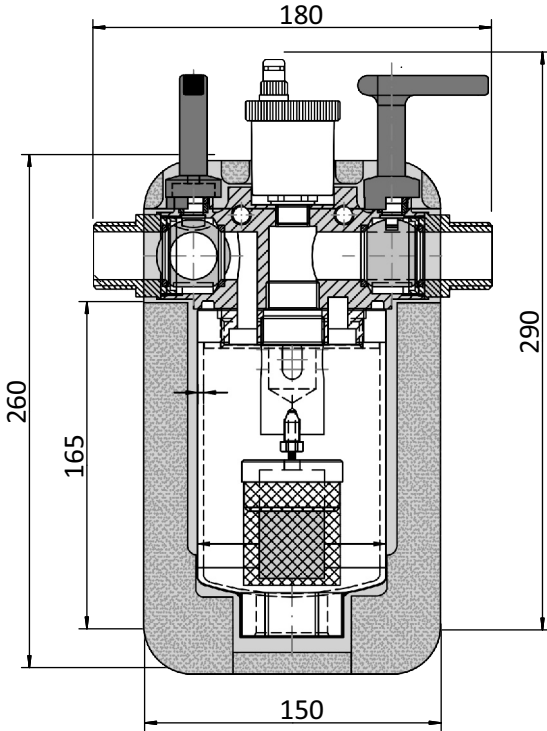

SorbOx S/SI L/LI performance details

| | |
|--------------------------|-----------------------|
| Flow rate | < 3 m ³ /h |
| Connection dimension: | 1" |
| Max. operating pressure: | < 6 bar |
| Max. temperature: | < 90° C |

SorbOx S/SI L/LI flow pressure drop

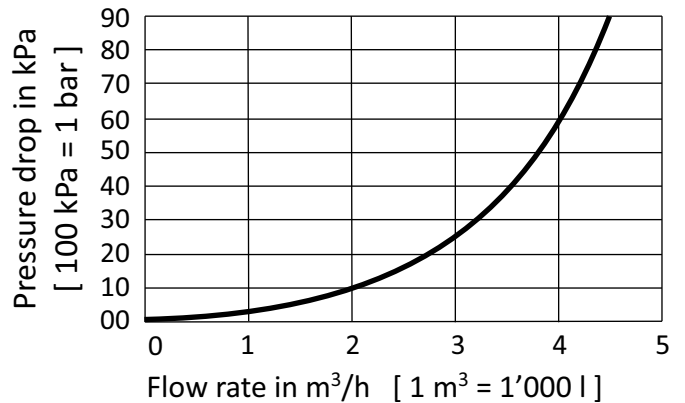

SorbOx® L/LI (against limescale, rust, gases)

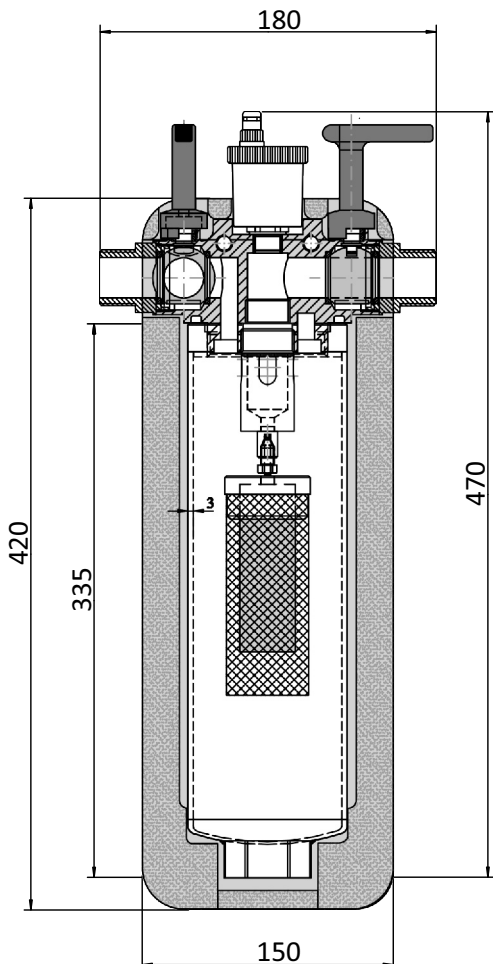

System water conductivity
μS/cm

SorbOx® cartridge capacity:
Liters demineralized water

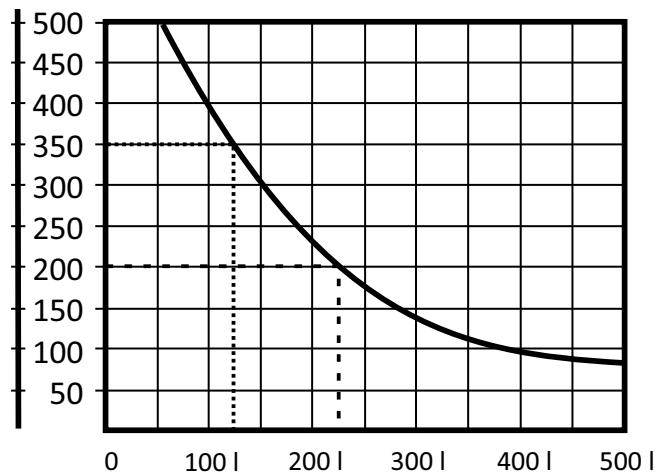

Example 1

At a conductivity of 350 μS/cm the SorbOx® cartridge will handle around 125 liters FD [fully desalinated] water

Example 2 - - - - -

At a conductivity of 200 μS/cm the SorbOx® cartridge will handle around 225 liters FD [fully desalinated] water

Service

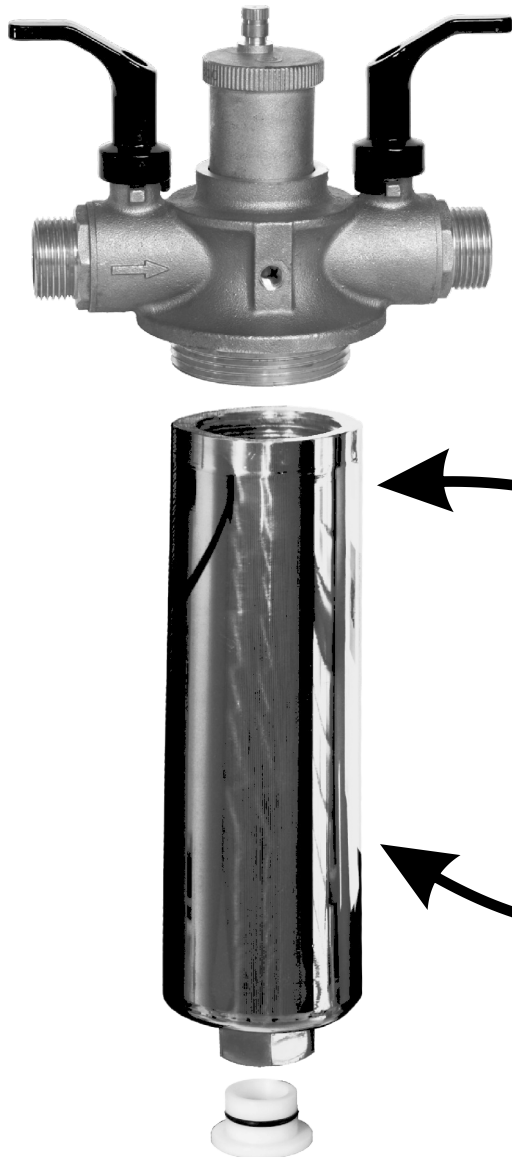

Drain sludge collector annually or as required.

1. Close both ball valves
2. Undo trap
3. Extract magnet from the bottom of the trap
4. Flush trap
5. Check gasket
6. Replace trap
7. Insert magnet
8. Open inlet valve until all air has escaped
9. Open outlet valve

Option SorbOx® L Demineralization cartridge

Insert into the filter head in place of the protective anode and replace the filter trap. For 1 to 3 days, allow to run concurrently with the circulation pump in heating mode. For full desalination of around 150 l system water or to remove residual minerals. Rechecking the electrical conductivity is recommended.

Replace protective anode with gas bubble separator every 3 years or as required.

1. Close both ball valves
2. Undo trap
3. Undo protective anode
4. Insert new protective anode
5. Check gasket
6. Replace trap
7. Open inlet valve until all air has escaped
8. Open outlet valve