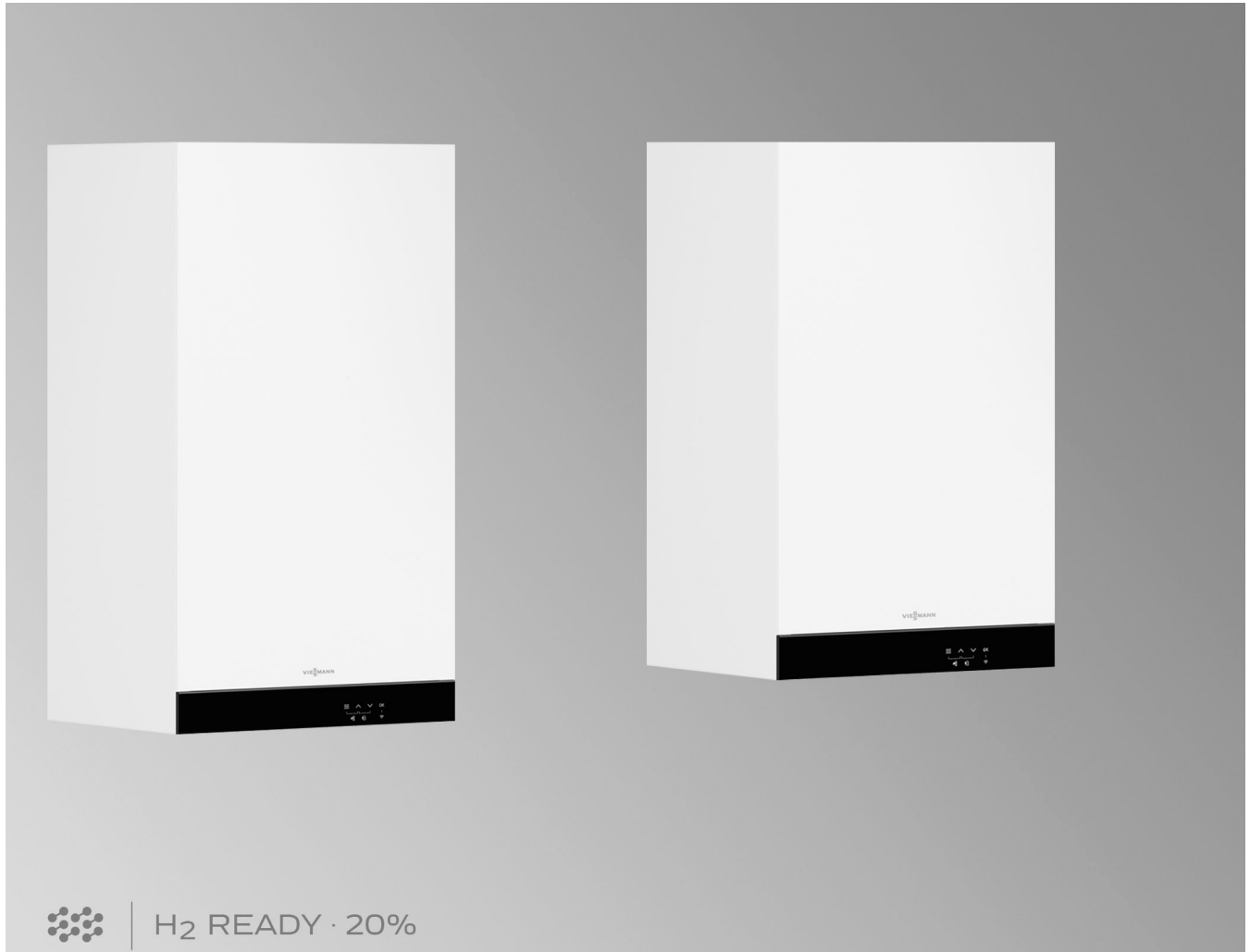

Technical guide

H₂ READY · 20%**VITODENS 050-W** Type B0HA, B0KA,
BPKAWall mounted gas condensing boiler
3.2 to 25.0 kW
Natural gas and LPG version**VITODENS 100-W** Type B1GAWall mounted gas condensing boiler
3.2 to 32.0 kW
Natural gas and LPG version

Index

1. Vitodens 050-W	1.1 Product description	4
	1.2 Specification	6
	■ Gas condensing system boiler	6
	■ Gas condensing combi boiler	8
	■ Variable speed heating circuit pump	11
	■ Standby instantaneous water heater (gas condensing combi boiler)	12
2. Vitodens 100-W, type B1GA	2.1 Product description	14
	2.2 Specification	15
	■ Gas condensing boiler	15
	■ Vitodens 100-W, type B1GA 25 kW	17
	■ Vitodens 100-W, type B1GA 32 kW	19
3. Separate DHW cylinders for Vitodens 050-W	3.1 Vitocell 100-W below the boiler	21
	■ Delivered condition	23
	3.2 Vitocell 100-W adjacent to the boiler for dual mode DHW heating	24
	■ Delivered condition	26
4. Installation accessories	4.1 Vitodens 050-W installation accessories	27
	■ Pre-plumbing jigs	27
	■ Valves/fittings	27
	■ Mounting frame	28
	■ Further accessories	29
	■ Connections between the Vitodens and the DHW cylinder	31
	4.2 Installation accessories for Vitodens 100-W	33
5. Design information	5.1 Siting, installation	33
	■ Siting conditions for open flue operation (appliance type B)	33
	■ Siting conditions for room sealed operation (appliance type C)	34
	■ Operation of the Vitodens in wet rooms	35
	■ Electrical connection	35
	■ Gas connection	35
	■ Minimum clearances	36
	■ Installation of the Vitodens 050-W	36
	■ Replacing third party boilers with the Vitodens 050-W	41
	5.2 Connections on the water side	44
	■ Connection on the DHW side	44
	5.3 Condensate connection	46
	■ Condensate drain pipe and neutralisation	46
	5.4 Hydraulic connection	47
	■ General	47
	■ Expansion vessels	49
	5.5 Intended use	49
6. Control unit	6.1 Layout and functions	49
	■ Modular design	49
	■ Functions	50
	■ Frost protection function	51
	■ Heating curve setting (slope and level)	51
	■ Flow temperature sensor	51
	■ Cylinder temperature sensor	51
	6.2 Specification – control unit	52
	6.3 Accessories for control unit	52
	■ Vitotrol 100 RT	53
	■ Vitotrol 100, type UTA	53
	■ Vitotrol 100, type UTDB	53
	■ Vitotrol 100, type UTDB	54
	■ Vitotrol 100, type UTDB-RF	54
	■ Vitotrol 100, type UTDB-RF	55
	■ Vitotrol 100, type UTDB-RF	55
	■ Vitotrol 100, type UTDB-RF2	55
	■ OpenTherm modulating room temperature controller	56
	■ Contact temperature limiter	56
	■ Outside temperature sensor	56
	■ Outside temperature sensor	57
	■ Cylinder demand junction box	57
	■ Connectivity pack	57
7. Appendix	7.1 Regulations / Directives	57

	■ Regulations and directives	57
8. Keyword index	58

1.1 Product description

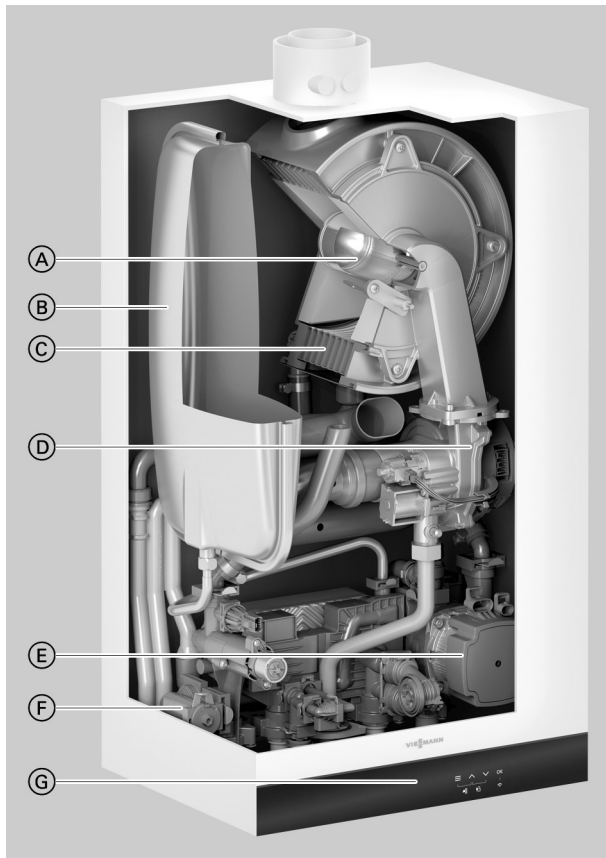

- Ⓐ Modulating MatriX-Plus burner with intelligent Lambda Pro combustion controller for extremely clean combustion and quiet operation
- Ⓑ Integral diaphragm expansion vessel
- Ⓒ Inox-Radial heat exchanger made from stainless steel – for high operational reliability, a long service life and high heating output on a very small footprint
- Ⓓ Variable speed combustion air fan for quiet and economical operation
- Ⓔ Integral, variable speed high efficiency circulation pump
- Ⓕ Hydraulics
- Ⓖ Digital boiler control unit with 7-segment display

The MatriX-Plus burner and the stainless steel Inox-Radial heat exchanger ensure the high energy efficiency of this combination, as well as its long-term high heating convenience.

All sizes of the Vitodens 050-W are equipped with the automatic Lambda Pro combustion controller. Modulation range down to 1:8 (25 kW).

The integral, variable speed high efficiency circulation pump reduces power consumption by up to 70 %.

Recommended applications

- New build
- Modernisation

Benefits at a glance

- Seasonal central heating energy efficiency η_s up to 92 % (label A).
- Low cycle frequency, even with low heat demand, due to optimised pauses and a wide modulation range down to 1:8 (25 kW)
- Durable and efficient thanks to Inox-Radial stainless steel heat exchanger
- MatriX-Plus burner with Lambda Pro combustion controller for permanently high efficiency and clean combustion.
- Power saving, high efficiency circulation pump
- Straightforward operation via control unit with LED display and touch buttons
- Web-enabled through integral WiFi interface for operation and service via Viessmann apps, depending on the version

Delivered condition

Wall mounted gas condensing boiler with Inox-Radial heat exchanger, modulating MatriX-Plus burner for natural gas and LPG to DVGW Code of Practice G260, hydraulics and variable speed high efficiency circulation pump.

Weather-compensated or constant temperature control unit with integral WiFi interface subject to version (not available with WiFi module in all countries).

Fully plumbed and wired. Colour of the epoxy-coated casing: Vito-pearlwhite.

Integral diaphragm expansion vessel (8 litre capacity).

Preset for operation with natural gas. Conversion within gas groups E/LL is not required. The conversion to LPG is made at the control unit (a conversion kit is not required). The gas condensing system boiler is suitable for operation with a hydrogen blend of up to 20 % by volume.

Note on multiple connection

*If multiple appliances are to be connected to a common flue system, the **multiple connection** version of the appliance will be required.*

*Using appliances for individual connection, or operating a mix of appliances for individual and multiple connection, on a common flue system is **not permitted**.*

*The multiple connection version is already fitted with an internal back draught safety device. When installing with multiple connections, it is **essential** to order an additional back draught safety device for the boiler flue connection to each appliance.*

*The multiple connection version **cannot** be operated with LPG.*

Accessories required (order separately)

Vitodens installation directly on a wall

Pre-plumbing jig for surface mounting:

- With fixings
- With valves/fittings
- With boiler drain & fill valve
- With gas shut-off valve with thermally activated safety shut-off valve

Vitodens 050-W (cont.)

Valves/fittings for surface mounting:

- With valves/fittings
- With boiler drain & fill valve
- With gas shut-off valve with thermally activated safety shut-off valve

Valves/fittings for flush mounting:

- With valves/fittings
- With boiler drain & fill valve
- With gas shut-off valve with thermally activated safety shut-off valve

Mounting frame for surface mounting (installed depth 90 mm):

- With fixings
- With valves/fittings
- With boiler drain & fill valve
- With angle gas valve with thermally activated safety shut-off valve

Vitodens installation in front of a wall

Plumbing wall mounting frame (installed depth 110 mm):

- With fixings

A pre-plumbing jig or valves/fittings for surface mounting/flush mounting must be ordered separately for the plumbing wall mounting frame.

Tested quality

 CE designation according to current EU Directives

Meets the requirements for the "Blue Angel" ecolabel to RAL UZ 61.

1.2 Specification

Gas condensing system boiler

Gas boiler, type B and C, category I _{2N3P}		BOHA	
Type			
Rated heating output range (details to EN 15502) T _F /T _R = 50/30 °C			
Natural gas	kW	3.2 to 19.0	3.2 to 25.0
LPG	kW	3.2 to 19.0	3.2 to 25.0
Rated heating output range (details to EN 15502) T _F /T _R = 80/60 °C			
Natural gas	kW	2.9 to 17.0	2.9 to 22.5
LPG	kW	2.9 to 17.0	2.9 to 22.5
Rated heating output for DHW heating			
Natural gas	kW	2.9 to 17.3	2.9 to 22.8
LPG	kW	2.9 to 17.3	2.9 to 22.8
Rated heat input (Q_n)			
Natural gas	kW	3.0 to 18.0	3.0 to 23.6
LPG	kW	3.0 to 18.0	3.0 to 23.6
Rated heat input for DHW heating (Q_{nw})			
Natural gas	kW	3.0 to 18.2	3.0 to 24.0
LPG	kW	3.0 to 18.2	3.0 to 24.0
Product ID		CE-0063DL3422	
IP rating to EN 60529		IP X4 to EN 60529	
NO _x		6	6
Gas supply pressure			
Natural gas	mbar	20	20
	kPa	2	2
LPG	mbar	50	50
	kPa	5	5
Max. perm. gas supply pressure^{*1}			
Natural gas	mbar	13 to 25.0	13 to 25.0
	kPa	1.3 to 2.5	1.3 to 2.5
LPG	mbar	25 to 57.5	25 to 57.5
	kPa	2.5 to 5.75	2.5 to 5.75
Sound power level (to EN ISO 15036-1)			
– At partial load	dB(A)	33	33
– At rated heating output (DHW heating)	dB(A)	47	49
Power consumption (in the delivered condition)		45	64
Rated voltage	V	230	
Rated frequency	Hz	50	
Appliance fuse protection	A	4.0	
Backup fuse (power supply)	A	16	
Communication module (integral)			
WiFi frequency band	MHz	2400 to 2483.5	
Max. transmission power	dBm	20	
Low power radio frequency band	MHz	2400 to 2483.5	
Max. transmission power	dBm	10	
Supply voltage	V \equiv	24	
Power consumption	W	4	
Electronic temperature limiter setting (TN)	°C	91	
Electronic temperature limiter setting	°C	110	
Electronic flue gas temperature limiter setting	°C	110	
Permissible ambient temperature			
– During operation	°C	+5 to +40	
– During storage and transport	°C	-5 to +60	
Weight			
– Excl. heating water and packaging	kg	35	35
– Incl. heating water	kg	41	41
Water capacity (excl. diaphragm expansion vessel)	l	3.0	
Max. flow temperature	°C	82	
Max. flow rate (Limit for the use of hydraulic separation)	l/h	See residual head graph	
Nominal circulating water volume At T _F /T _R = 80/60 °C	l/h	752	988

*1 If the gas supply pressure is higher than the maximum permissible value, install a separate gas pressure governor upstream of the system.

Vitodens 050-W (cont.)

Gas boiler, type B and C, category I _{2N3P}			
Type	B0HA		
Rated heating output range (details to EN 15502)			
T _F /T _R = 50/30 °C			
Natural gas	kW	3.2 to 19.0	3.2 to 25.0
LPG	kW	3.2 to 19.0	3.2 to 25.0
T _F /T _R = 80/60 °C			
Natural gas	kW	2.9 to 17.0	2.9 to 22.5
LPG	kW	2.9 to 17.0	2.9 to 22.5
Diaphragm expansion vessel			
– Capacity	l	8	8
– Pre-charge pressure	bar	0.75	0.75
	kPa	75	75
Permiss. operating pressure	bar	3	3
	MPa	0.3	0.3
Connections (with connection accessories)			
– Boiler flow and return	G	¾	¾
– Cold water and DHW	G	½	½
Dimensions			
– Length	mm	300	300
– Width	mm	400	400
– Height	mm	700	700
Gas connection	R	¾	¾
Supply values			
Relative to the max. load and 1013 mbar/15 °C			
With gas			
Natural gas E	m ³ /h	1.88	2.48
Natural gas LL	m ³ /h	2.19	2.88
LPG	kg/h	1.4	1.83
Flue gas parameters			
Temperature (at a return temperature of 30 °C)			
– At rated heating output	°C	41	46
– At partial load (individual connection)	°C	38	38
Temperature (at a return temperature of 60 °C, for DHW heating)	°C	65	67
Overheating temperature	°C	120	
Available draught	Pa	250	250
	mbar	2.5	2.5
Available draught for B23P	Pa	261	473
	mbar	2.61	4.73
Max. amount of condensate	l/h	2.5	3.3
To DWA-A 251			
Condensate connection (hose nozzle)	Ø mm	20 to 24	20 to 24
Flue gas connection	Ø mm	60	60
Ventilation air connection	Ø mm	100	100
Standard seasonal efficiency [to DIN] at			
T _F /T _R = 40/30 °C	%	Up to 98 (H _s) [gross cv]	
Energy efficiency class		A	A

Note

The supply values are only for reference (e.g. in the gas contract application) or for a supplementary, rough estimate to check the volumetric settings. Due to factory settings, the gas pressure must not be altered from these values. Reference: 15 °C, 1013 mbar (101.3 kPa).

Vitodens 050-W (cont.)

Gas condensing combi boiler

Gas boiler, type B and C, category I _{2N3P}		B0KA, BPKA	
Type			
Rated heating output range (details to EN 15502) T _F /T _R = 50/30 °C			
Natural gas	kW	3.2 to 19.0	3.2 (7.0 ^{*2}) to 25.0
LPG	kW	3.2 to 19	3.2 to 25
T_F/T_R = 80/60 °C			
Natural gas	kW	2.9 to 17.0	2.9 (6.3 ^{*2}) to 22.5
LPG	kW	2.9 to 17	2.9 to 22.5
Rated heating output for DHW heating			
Natural gas	kW	2.9 to 25.4	2.9 (6.3 ^{*2}) to 30.0
LPG	kW	2.9 to 25.4	2.9 to 30
Rated heat input (Q_n)			
Natural gas	kW	3.0 to 18.0	3.0 (6.5 ^{*2}) to 23.6
LPG	kW	3.0 to 18.0	3.0 to 23.6
Rated heat input for DHW heating (Q_{nw})			
Natural gas	kW	3.0 to 26.7	3.0 (6.5 ^{*2}) to 31.5
LPG	kW	3.0 to 26.7	3.0 to 31.5
Product ID		CE-0063DL3422	
IP rating to EN 60529		IP X4 to EN 60529 B1BA: IP X5 to EN 60529	
NO _x		6	6
Gas supply pressure			
Natural gas	mbar	20	20
	kPa	2	2
LPG	mbar	50	50
	kPa	5	5
Max. perm. gas supply pressure^{*3}			
Natural gas	mbar	25	25
	kPa	2.5	2.5
LPG	mbar	25 to 57.5	25 to 57.5
	kPa	2.5 to 5.75	2.5 to 5.75
Sound power level (to EN ISO 15036-1)			
– At partial load	dB(A)	33	33
– At rated heating output (DHW heating)	dB(A)	52	53
Power consumption (in the delivered condition)		45	64
Rated voltage	V	230	
Rated frequency	Hz	50	
Appliance fuse protection	A	4	
Backup fuse (power supply)	A	16	
Communication module (integral)			
WiFi frequency band	MHz	2400 to 2483.5	
Max. transmission power	dBm	20	
Low power radio frequency band	MHz	2400 to 2483.5	
Max. transmission power	dBm	10	
Supply voltage	V $\overline{=}$	24	
Power consumption	W	4	
Electronic temperature limiter setting (TN)	°C	91	
Electronic temperature cut-out setting	°C	110	
Electronic flue gas temperature limiter setting	°C	110	
Permissible ambient temperature			
– During operation	°C	+5 to +40	
– During storage and transport	°C	-5 to +60	
Weight			
– Excl. heating water and packaging	kg	35	35
– Incl. heating water	kg	41	41
Water capacity (excl. diaphragm expansion vessel)	l	3.0	3.0
Max. flow temperature	°C	82	82
Max. flow rate (Limit for the use of hydraulic separation)	l/h	See residual head graphs	

^{*2} Appliances for multiple connection of type B0KA-[kW]-M

^{*3} If the gas supply pressure is higher than the maximum permissible value, install a separate gas pressure governor upstream of the system.



Vitodens 050-W (cont.)

Gas boiler, type B and C, category I _{2N3P}		B0KA, BPKA	
Type			
Rated heating output range (details to EN 15502)			
$T_F/T_R = 50/30\text{ °C}$			
Natural gas	kW	3.2 to 19.0	3.2 (7.0 ^{*2}) to 25.0
LPG	kW	3.2 to 19	3.2 to 25
$T_F/T_R = 80/60\text{ °C}$			
Natural gas	kW	2.9 to 17.0	2.9 (6.3 ^{*2}) to 22.5
LPG	kW	2.9 to 17	2.9 to 22.5
Nominal circulating water volume	l/h	752	988
At $T_F/T_R = 80/60\text{ °C}$			
Diaphragm expansion vessel			
– Capacity	l	8	8
– Pre-charge pressure	bar	0.75	0.75
	kPa	75	75
Permiss. operating pressure	bar	3	3
	MPa	0.3	0.3
Connections (with connection accessories)			
– Boiler flow and return	G	¾	¾
– Cold water and DHW	G	½	½
Dimensions			
– Length	mm	300	300
– Width	mm	400	400
– Height	mm	700	700
Gas connection	R	¾	¾
Supply values			
Relative to the max. load and 1013 mbar/15 °C			
Natural gas E	m ³ /h	1.88	2.48
Natural gas LL	m ³ /h	2.19	2.88
LPG	kg/h	1.4	1.83
Flue gas parameters			
Temperature (at a return temperature of 30 °C)			
– At rated heating output	°C	41	46
– At partial load	°C	38	38
Temperature (at a return temperature of 60 °C, for DHW heating)			
	°C	65	67
Overheating temperature	°C	120	
Mass flow rate (for DHW heating)			
Natural gas			
– At the max. rated heating output	kg/h	31.7	41.6
– At partial load	kg/h	5.6	5.6 (9.8)
Available draught (with individual connection)	Pa	250	250
	mbar	2.5	2.5
Available draught for B23P			
	Pa	597	473
	mbar	5.97	4.73
Max. amount of condensate	l/h	3.8	4.4
To DWA-A 251			
Condensate connection (hose nozzle)	Ø mm	20 to 24	20 to 24
Flue gas connection	Ø mm	60	60
Ventilation air connection	Ø mm	100	100
Standard seasonal efficiency [to DIN] at			
$T_F/T_R = 40/30\text{ °C}$	%	Up to 98 (H _s) [gross cv]	
Energy efficiency class		A	A

Note

The supply values are only for reference (e.g. in the gas contract application) or for a supplementary, rough estimate to check the volumetric settings. Due to factory settings, the gas pressure must not be altered from these values. Reference: 15 °C, 1013 mbar (101.3 kPa).

For specification of flue system C₁₀, see technical guide for Vitodens flue systems.

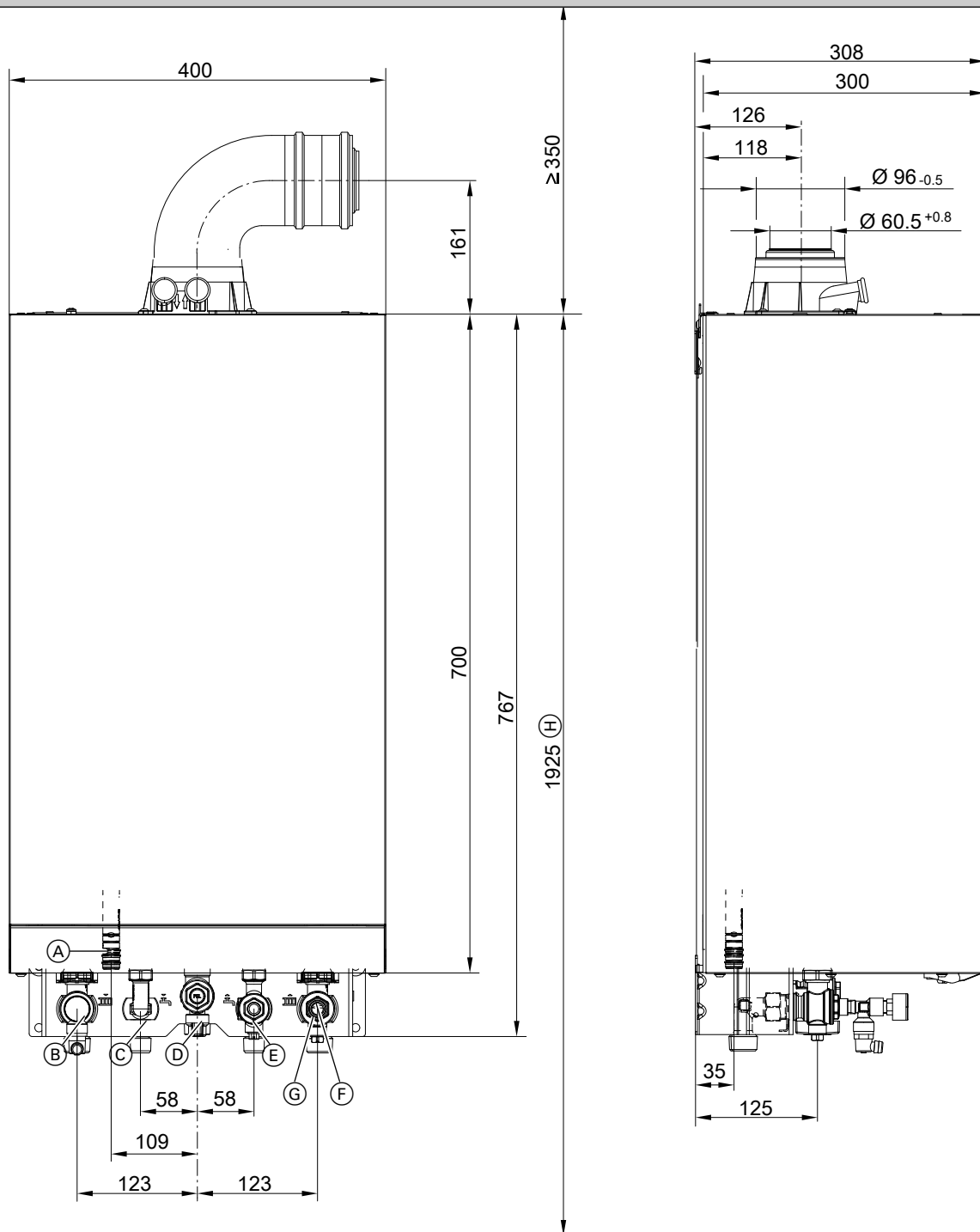

Illustration shows a gas condensing combi boiler

- (A) Condensate drain
- (B) Heating flow
- (C) DHW (gas condensing combi boiler)
Cylinder flow (gas condensing system boiler)
- (D) Gas connection
- (E) Cold water (gas condensing combi boiler)
Cylinder return (gas condensing system boiler)
- (F) Heating return
- (G) Filling/draining
- (H) Dimension for siting with DHW cylinder below the boiler

Vitodens 050-W (cont.)

Note

This boiler (IP rating: IP X4) is approved for installation in wet rooms inside safety zone 1, to DIN VDE 0100. Exposure to jets of water must be prevented.

For open flue operation, the boiler may only be operated with a splash cover.

Observe the requirements of DIN VDE 0100.

Variable speed heating circuit pump

The integral circulation pump is a highly efficient pump with substantially lower power consumption than conventional pumps.

The pump speed and consequently the pump rate are controlled subject to the outside temperature and the switching times for heating mode or reduced mode. The control unit transmits the currently specified speeds to the circulation pump via a PWM signal.

The min. and max. speeds and the speed for reduced mode can be matched to the existing heating system via parameters at the control unit.

Setting (%) in group heating circuit 1:

- Min. speed: Parameter 1102.0
- Max. speed: Parameter 1102.1

Specification – circulation pump

Rated heating output	kW	19	25
Type		B0KA BPKA B0HA	B0KA BPKA B0HA
Circulation pump	Type	UPM3 15-60	UPM3 15-60
Rated voltage	V~	230	230
Power consumption			
– max.	W	60	60
– min.	W	2	2
– Delivered condition	W	21.9	34.3
Energy efficiency class		A	A
Energy efficiency index (EEI)		≤ 0.20	≤ 0.20

- In the delivered condition, the minimum pump rate and the maximum pump rate are set to the following values:

Rated heating output in kW	Speed settings in the delivered condition in %	
	Min. pump rate	Max. pump rate
19	40	100
25	40	100

- In conjunction with a low loss header, heating water buffer cylinder and heating circuits with mixer, the internal circulation pump runs at a constant speed.

Vitodens 050-W (cont.)

Residual head of integral circulation pump

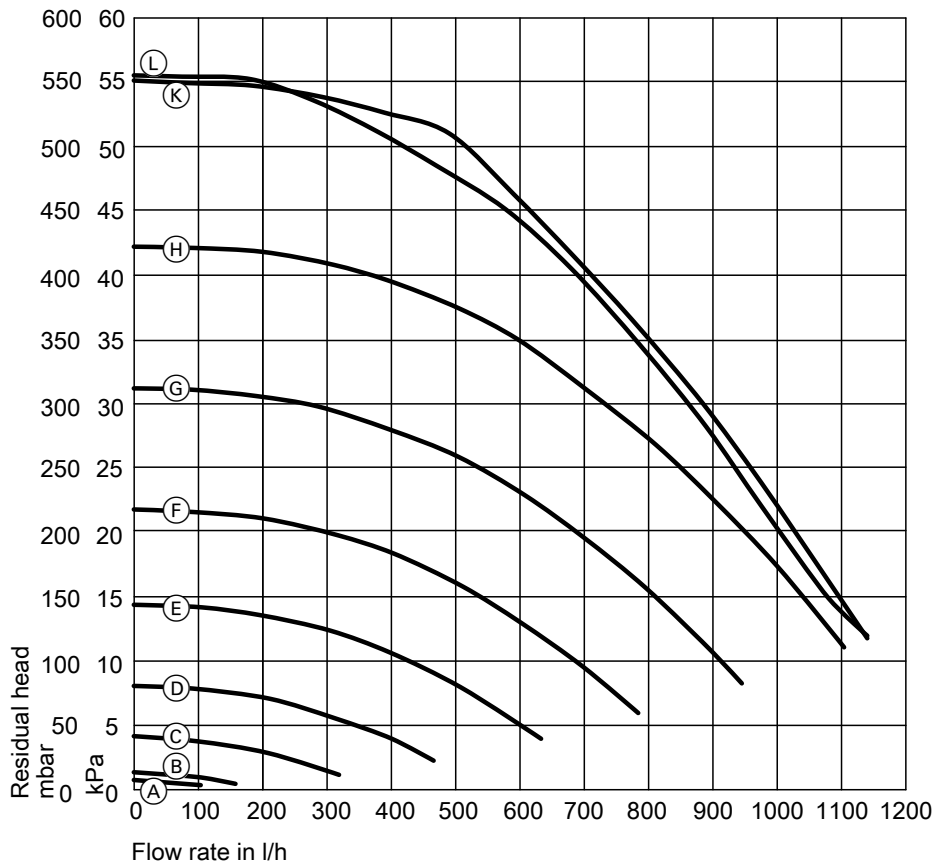

(M) Upper operational limit (integral bypass opens)

Curve	Pump rate of circulation pump
(A)	10 %
(B)	20 %
(C)	30 %
(D)	40 %
(E)	50 %
(F)	60 %
(G)	70 %
(H)	80 %
(K)	90 %
(L)	100 %

Standby instantaneous water heater (gas condensing combi boiler)

A standby instantaneous water heater is integrated into the Vitodens 050-W, type B0KA BPKA.

Output levels

Rated heating output, gas condensing combi boiler	kW	19.0	25.0
Continuous DHW output	kW	25.4	30.0
for DHW heating from 10 to 45 °C	l/h	666	764
Draw-off rate	l/min	3 to 12	3 to 14
Outlet temperature, adjustable	°C	10 to 60	10 to 60

DHW temperature subject to flow rate

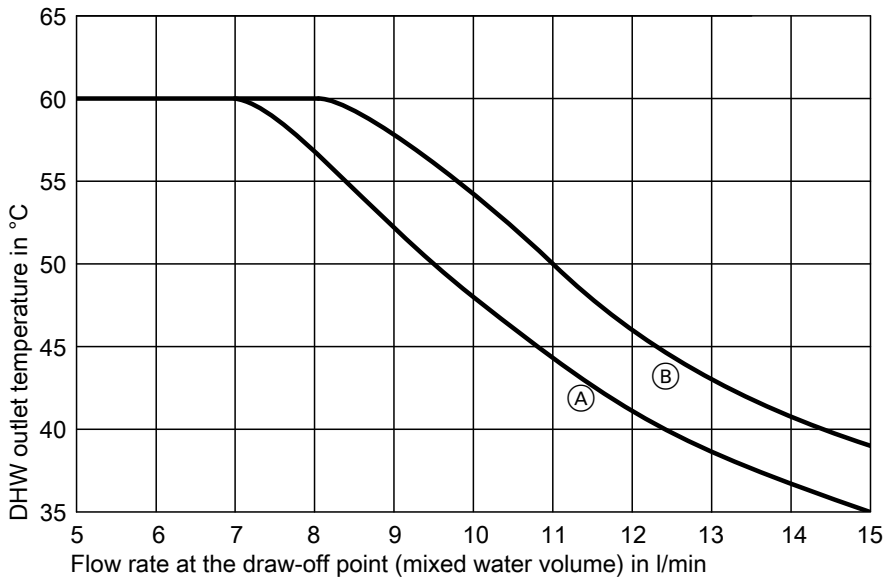

- (A) 19 kW
- (B) 25 kW

The graph illustrates the changes in the outlet temperature, subject to the flow rate at the draw-off point.

If a greater volume of water is required, cold water needs to be admixed, which reduces the outlet temperature.

The illustrated outlet temperature characteristics are based on a cold water inlet temperature of 10 °C.

2.1 Product description



- Ⓐ Inox-Radial heat exchanger made from stainless steel – for high operational reliability, a long service life and high heating output on a very small footprint
- Ⓑ Modulating MatriX-Plus burner with intelligent Lambda Pro combustion controller for extremely clean combustion and quiet operation
- Ⓒ Hydraulics with integral, variable speed high efficiency circulation pump
- Ⓓ Digital boiler control unit with 7-segment display

The Vitodens 100-W (heat only) offers stainless steel condensing technology on the smallest footprint and at an especially attractive price. Thanks to its compact dimensions, it is easy to install and fits anywhere. In a kitchen wall unit, in the bathroom, under the roof or in recesses and corners. Side clearances are not required, since all components can be accessed from the front. With its Inox-Radial heat exchanger made from high grade stainless steel, the Vitodens 100-W offers high reliability, a long service life, and permanently high utilisation of condensing technology. The MatriX-Plus burner of the Vitodens 100-W is also stainless steel. It is particularly economical, because it adapts to the heat demand through modulating operation.

Recommended applications

- Installation in detached and terraced houses
- Replacement of boilers in various types of systems, including those with several heating circuits and underfloor heating

Benefits at a glance

- Seasonal central heating energy efficiency η_s up to 92 % (label A).
- Low cycle frequency, even with low heat demand, due to optimised pauses and a wide modulation range down to 1:8
- Durable and efficient thanks to Inox-Radial stainless steel heat exchanger

- MatriX-Plus burner with Lambda Pro combustion controller for permanently high efficiency and clean combustion.
- Straightforward operation via control unit with LED display and touch buttons

Delivered condition

Gas condensing boiler with Inox-Radial heat exchanger and modulating MatriX-Plus burner for natural gas and LPG. Fully plumbed and wired.

Weather-compensated or constant temperature control unit.

Colour of the epoxy-coated casing: Vitopearlwhite.

Preset for operation with natural gas. Conversion within gas groups E/LL is not required. The conversion to LPG is made at the control unit (a conversion kit is not required). The gas condensing system boiler is suitable for operation with a hydrogen blend of up to 20 % by volume.

Tested quality

CE CE designation according to current EU Directives

Meets the requirements for the "Blue Angel" ecolabel to RAL UZ 61.

2.2 Specification

Gas condensing boiler

Gas boiler, type B and C, category I _{2N3P}		B1GA				
Type						
Rated heating output range (details to EN 15502)						
T _F /T _R = 50/30 °C						
Natural gas	kW	3.2 to 11	3.2 to 16	3.2 to 19	3.2 to 25	3.2 to 32
LPG	kW	3.2 to 11	3.2 to 16	3.2 to 19	3.2 to 25	3.2 to 32
T _F /T _R = 80/60 °C						
Natural gas	kW	2.9 to 9.9	2.9 to 14.4	2.9 to 17.0	2.9 to 22.5	2.9 to 28.7
LPG	kW	2.9 to 9.9	2.9 to 14.4	2.9 to 17.0	2.9 to 22.5	2.9 to 28.7
Rated heat input (Q_n)						
Natural gas	kW	3 to 10.4	3 to 15.1	3 to 18.0	3 to 23.6	3 to 30.2
LPG	kW	3 to 10.4	3 to 15.1	3 to 18.0	3 to 23.6	3 to 30.2
Product ID		CE-0063DL3422				
IP rating to EN 60529		IP X4 to EN 60529				
NO _x		6	6	6	6	6
Gas supply pressure						
Natural gas	mbar	20	20	20	20	20
	kPa	2	2	2	2	2
LPG	mbar	50	50	50	50	50
	kPa	5	5	5	5	5
Max. perm. gas supply pressure*⁴						
Natural gas	mbar	25	25	25	25	25
	kPa	2.5	2.5	2.5	2.5	2.5
LPG	mbar	25 to 57.5	25 to 57.5	25 to 57.5	25 to 57.5	25 to 57.5
	kPa	2.5 to 5.75	2.5 to 5.75	2.5 to 5.75	2.5 to 5.75	2.5 to 5.75
Sound power level (to EN ISO 15036-1)						
– At partial load	dB(A)	33	33	33	33	33
– At rated heating output	dB(A)	41	44	46	49	52
Power consumption (in the delivered condition)		W	38	42	45	64
Rated voltage		V	230			
Rated frequency		Hz	50			
Appliance fuse protection		A	4.0			
Backup fuse (power supply)		A	16			
Electronic temperature limiter setting (TN)		°C	91			
Electronic temperature cut-out setting		°C	110			
Permissible ambient temperature						
– During operation	°C	+5 to +40				
– During storage and transport	°C	-5 to +60				
Weight						
– Excl. heating water and packaging	kg	23	23	23	23	26
– Incl. heating water	kg	25	25	25	25	28
Water capacity (excl. diaphragm expansion vessel)		l	3	3	3	3
Max. flow temperature		°C	82	82	82	82
Nominal circulating water volume At T _F /T _R = 80/60 °C		l/h	434	633	752	988
Permiss. operating pressure		bar	3	3	3	3
	MPa	0.3	0.3	0.3	0.3	0.3
Connections (with connection accessories)						
Boiler flow and return	R	¾	¾	¾	¾	¾
Dimensions						
– Length	mm	285	285	285	285	340
– Width	mm	375	375	375	375	375
– Height	mm	600	600	600	600	600
Gas connection		R	¾	¾	¾	¾
Supply values Relative to the max. load and 1013 mbar/15 °C						
– Natural gas E	m ³ /h	1.1	1.6	1.88	2.48	3.16
– Natural gas LL	m ³ /h	1.3	1.86	2.19	2.88	3.68
– LPG	kg/h	0.81	1.17	1.4	1.83	2.35

*⁴ If the gas supply pressure is higher than the maximum permissible value, install a separate gas pressure governor upstream of the system.

Vitodens 100-W, type B1GA (cont.)

Gas boiler, type B and C, category I _{2N3P}		B1GA				
Type						
Rated heating output range (details to EN 15502)						
T _F /T _R = 50/30 °C						
Natural gas	kW	3.2 to 11	3.2 to 16	3.2 to 19	3.2 to 25	3.2 to 32
LPG	kW	3.2 to 11	3.2 to 16	3.2 to 19	3.2 to 25	3.2 to 32
T _F /T _R = 80/60 °C						
Natural gas	kW	2.9 to 9.9	2.9 to 14.4	2.9 to 17.0	2.9 to 22.5	2.9 to 28.7
LPG	kW	2.9 to 9.9	2.9 to 14.4	2.9 to 17.0	2.9 to 22.5	2.9 to 28.7
Flue gas parameters						
Temperature (at a return temperature of 30 °C)						
– At rated heating output	°C	39	40	41	46	59
– At partial load	°C	38	38	38	38	38
Temperature (at a return temperature of 60 °C, for DHW heating)	°C	64	64	65	67	72
Available draught	Pa	250	250	250	250	250
	mbar	2.5	2.5	2.5	2.5	2.5
Available draught for B23P	Pa	111	186	261	473	635
	mbar	1.11	1.86	2.61	4.73	6.35
Max. amount of condensate To DWA-A 251	l/h	2.5	2.5	2.5	3.3	4.2
Condensate connection (hose nozzle)	Ø mm	20 to 24	21 to 24	20 to 24	20 to 24	20 to 24
Flue gas connection	Ø mm	60	60	60	60	60
Ventilation air connection	Ø mm	100	100	100	100	100
Standard seasonal efficiency [to DIN] at T _F /T _R = 40/30 °C	%	Up to 98 (H _s) [gross cv]				
Energy efficiency class		A	A	A	A	A

Note

The supply values are only for reference (e.g. in the gas contract application) or for a supplementary, rough estimate to check the volumetric settings. Due to factory settings, the gas pressure must not be altered from these values. Reference: 15 °C, 1013 mbar (101.3 kPa).

Vitodens 100-W, type B1GA (cont.)

Vitodens 100-W, type B1GA 25 kW

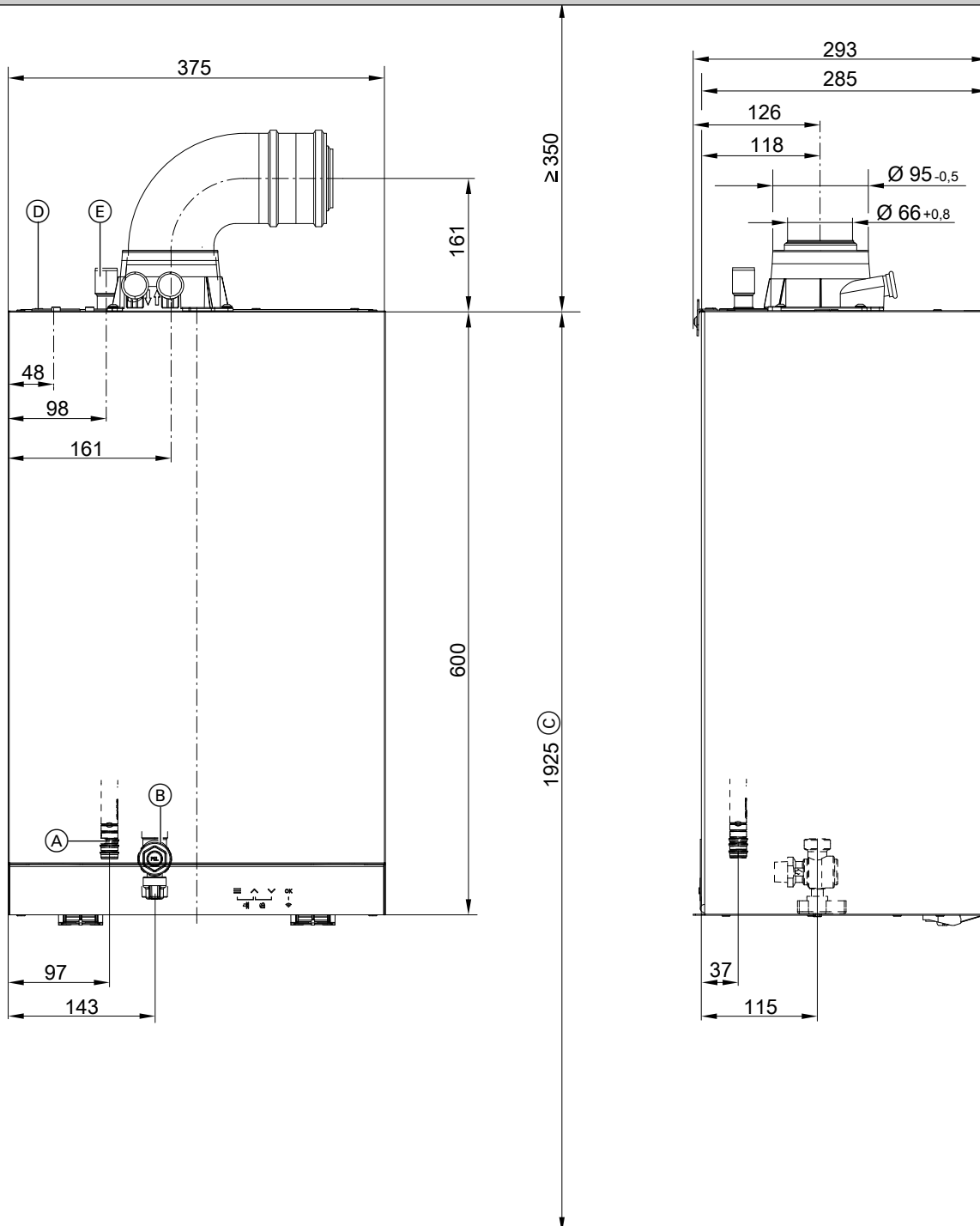

- (A) Condensate drain
- (B) Gas connection
- (C) Dimension for siting with DHW cylinder below the boiler
- (D) Heating flow
- (E) Heating return

6176070

Vitodens 100-W, type B1GA (cont.)

Note

This boiler (IP rating: IP X4) is approved for installation in wet rooms inside safety zone 1, to DIN VDE 0100. Exposure to jets of water must be prevented.

For open flue operation, the boiler may only be operated with a splash cover.

Observe the requirements of DIN VDE 0100.

Vitodens 100-W, type B1GA (cont.)

Vitodens 100-W, type B1GA 32 kW

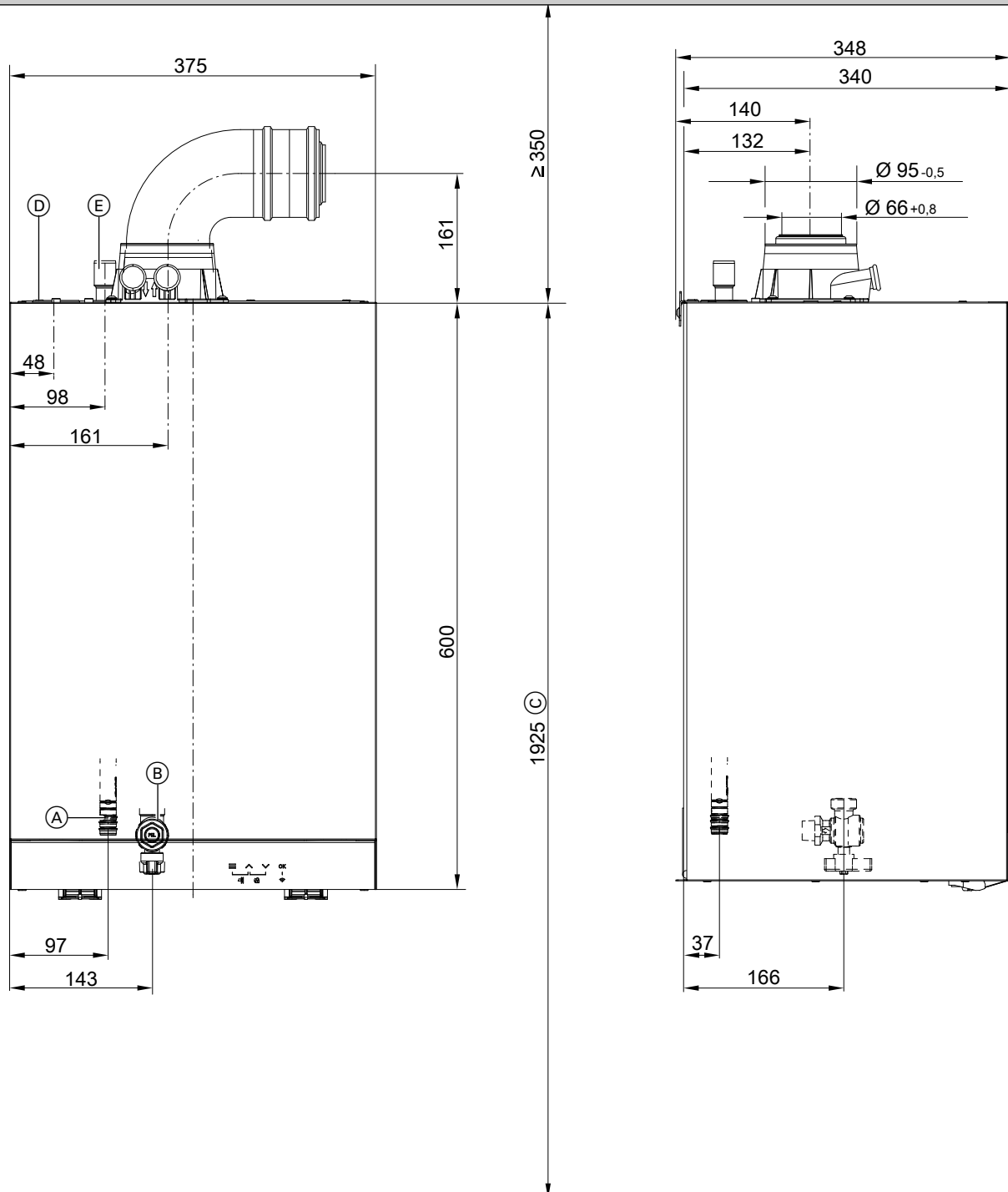

2

6176070

Vitodens 100-W, type B1GA (cont.)

Note

This boiler (IP rating: IP X4) is approved for installation in wet rooms inside safety zone 1, to DIN VDE 0100. Exposure to jets of water must be prevented.

For open flue operation, the boiler may only be operated with a splash cover.

Observe the requirements of DIN VDE 0100.

Separate DHW cylinders for Vitodens 050-W

3.1 Vitocell 100-W below the boiler

Specification

Type		CUGB	CUGB-A	CUGB	CUGB-A
Cylinder capacity	l	120		150	
Heating water capacity	l	6.5		6.5	
Gross volume	l	126.5		156.5	
DIN registration no.		Applied for			
Connections (male thread)					
Heating water flow and return	R	1	1	1	1
Hot and cold water	R	¾	¾	¾	¾
DHW circulation	R	¾	¾	¾	¾
Permissible temperatures					
– Heating water side	°C	160	160	160	160
– DHW side	°C	95	95	95	95
Permissible operating pressure					
Heating water and DHW sides	bar	10	10	10	10
	MPa	1	1	1	1
Standby heat loss	kWh/24 h	1.015	0.866	1.041	0.853
Dimensions					
Length a	mm	582	634	634	634
Width b	mm	∅ 582	∅ 634	∅ 634	∅ 634
Height c	mm	929	929	958	958
Weight	kg	55	58	61	61
Heating surface	m ²	1.0	1.0	1.0	1.0
Energy efficiency class		B	A	B	A
Colour		Vitopearlwhite			

Dimensions of type CUGB, CUGB-A, 120 and 150 l

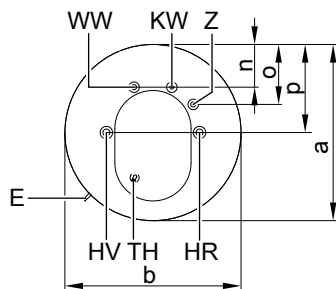
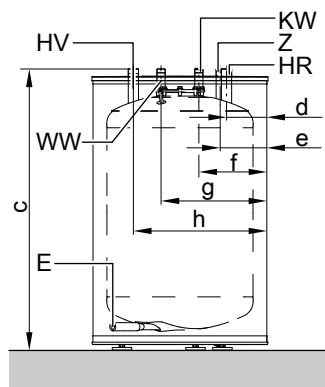

- HV Heating flow
- KW Cold water
- WW DHW
- TH Sensor well for cylinder temperature sensor (int. dia. 7 mm)
- Z DHW circulation

- E Drain
- HR Heating return

Separate DHW cylinders for Vitodens 050-W (cont.)

Dimensions of type CUGB, CUGB-A

Type	CUGB	CUGB-A	CUGB	CUGB-A
Capacity	120 l		150 l	
a mm	582	634	634	634
b mm	582	634	634	634
c mm	929	929	958	958
d mm	137	163	163	163
e mm	158	184	184	184
f mm	229	255	255	255
g mm	353	379	379	379
h mm	445	471	471	471
n mm	141	167	167	167
o mm	198	224	224	224
p mm	291	317	317	317

DHW performance data at rated heating output

Type CUGB, CUGB-A

Rated heating output of the wall mounted appliance for DHW heating	kW	16	18	19	22	24	25	32
Continuous DHW output	kW	16	18	19	22	24	24	24
For DHW heating from 10 to 45 °C and an average boiler water temperature of 78 °C	l/h	390	440	465	540	590	590	590
Performance factor N_L to DIN 4708								
Cylinder capacity								
120 l		1.2	1.2	1.2	1.2	1.2	1.2	1.2
150 l		1.6	1.6	1.6	1.6	1.6	1.6	1.6
Peak output over 10 min								
Cylinder capacity								
120 l	l/10 min	153	153	153	153	153	153	153
150 l	l/10 min	173	173	173	173	173	173	173

Pressure drop on the DHW side

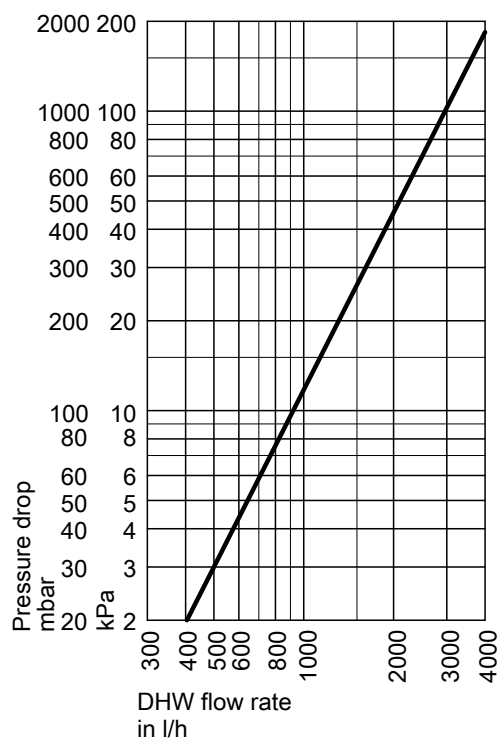

Separate DHW cylinders for Vitodens 050-W (cont.)

DHW performance data at rated heating output

Rated heating output	kW	17.5	23.0
For DHW heating			
Continuous DHW output	kW	17.5	23.0
For DHW heating from 10 to 45 °C and an average boiler water temperature of 78 °C	l/h	425	555
Performance factor N_L			
To DIN 4708			
Cylinder capacity 120 l		1.2	1.2
Cylinder capacity 150 l		1.6	1.6
Peak output			
Over 10 minutes			
Cylinder capacity 120 l	l/10 min	153	153
Cylinder capacity 150 l	l/10 min	173	173

Delivered condition

Vitocell 100-W, type CUGB and CUGB-A 100, 120 and 150 l

DHW cylinder made from steel with Ceraprotect enamel coating

- Welded sensor well for cylinder temperature sensor
- Threaded adjustable feet
- Protective magnesium anode
- Fitted thermal insulation

Colour of the epoxy-coated sheet steel casing: Vitopearlwhite

Separate DHW cylinders for Vitodens 050-W (cont.)

3.2 Vitocell 100-W adjacent to the boiler for dual mode DHW heating

For further specifications, see the separate datasheet for the Vitocell 100-B/100-W.

Type		CVBC
Cylinder capacity (AT: Actual water capacity)	l	300
Heating water capacity	l	16
Gross volume	l	316
DIN registration no.		Applied for
Connections (male thread)		
Heating water flow and return	R	1
Hot and cold water	R	1
DHW circulation	R	1
Permissible temperatures		
– Heating water side	°C	160
– DHW side	°C	95
– Solar side	°C	160
Permissible operating pressure on the heating water, solar and DHW sides	bar MPa	10 1
Standby heat loss	kWh/24 h	1.65
Dimensions		
Length a (∅)	mm	667
Width b	mm	714
Height d	mm	1687
Weight	kg	126
Energy efficiency class		B
Colour		
– Vitocell 100-B		Vitosilver
– Vitocell 100-W		Vitopearlwhite

Separate DHW cylinders for Vitodens 050-W (cont.)

Dimensions of type CVB, 300 l capacity

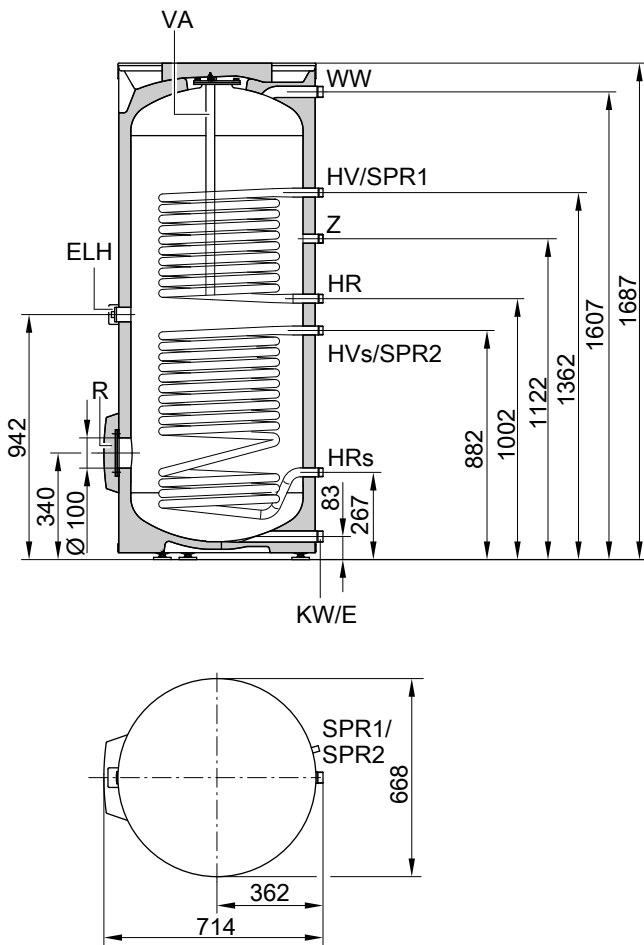

- E Drain
- ELH Immersion heater
- HR Heating water return
- HR_s Heating water return, solar thermal system
- HV Heating water flow
- HV_s Heating water flow, solar thermal system
- KW Cold water
- R Inspection and cleaning aperture with flange cover (also suitable for installation of an immersion heater)
- SPR1 Clamping device for securing immersion temperature sensors to the cylinder jacket, with fixing points for 3 immersion temperature sensors
- SPR2 Clamping device for securing immersion temperature sensors to the cylinder jacket, with fixing points for 3 immersion temperature sensors
- TH Thermometer (accessories)
- VA Protective magnesium anode
- WW DHW
- Z DHW circulation

DHW performance data at rated heating output

Rated heating output	kW	17.5	23.0
For DHW heating			
Continuous DHW output			
For DHW heating from 10 to 45 °C and an average boiler water temperature of 78 °C	kW	17.5	23.0
	l/h	425	555

Recommended positioning of the cylinder temperature sensor for solar operation

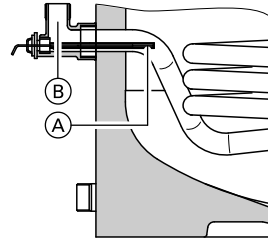

- Ⓐ Cylinder temperature sensor (solar control unit)
- Ⓑ Threaded elbow with sensor well (standard delivery)

Pressure drop on the DHW side

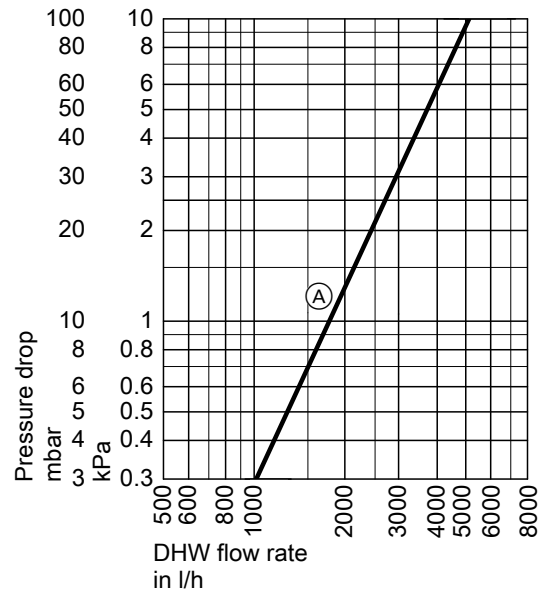

- Ⓐ 300 l capacity

Separate DHW cylinders for Vitodens 050-W (cont.)

Rated heating output For DHW heating	kW	17.5	23.0
Performance factor N_L^{*5} To DIN 4708		1.4	1.4
Peak output Over 10 minutes	l/10 min	164	164

Delivered condition

Delivered condition

Type CVBC

DHW cylinder with **300 l** capacity:

- Fitted thermal insulation
- Sheet steel casing, epoxy-coated: Vitoppearlwhite or Vitosilver
- Adjustable feet

- Cylinder and internal indirect coil made from steel, corrosion protection through Ceraprotect enamel coating
- Additional cathodic protection with protective magnesium anode
- 2 clamping devices for securing immersion temperature sensors to the cylinder jacket, each with fixing points for 3 immersion temperature sensors
- Threaded elbow with sensor well: Internal diameter 6.5 mm
- Connection for installing an immersion heater: R 1 1/2

*5 Values for the upper indirect coil.

Installation accessories

4.1 Vitodens 050-W installation accessories

Pre-plumbing jigs

Pre-plumbing jig for surface mounting
For gas condensing system boiler

Part no. ZK04307

Comprising:

- Fixings
- Valves/fittings, heating flow/heating return
- Boiler drain & fill valve
- Air vent valve
- Pressure gauge
- Gas shut-off valve with thermally activated safety shut-off valve

Connections (male thread)		
Gas shut-off valve	R	¾
Heating flow/heating return	R	¾

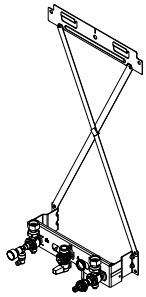

Comprising:

- Fixings
- Valves/fittings, heating flow/heating return
- Valves/fittings, cold water/DHW
- Boiler drain & fill valve
- Air vent valve
- Pressure gauge
- Gas shut-off valve with thermally activated safety shut-off valve

Connections (male thread)		
Gas shut-off valve	R	¾
Heating flow/heating return	R	¾
Cold water/DHW	R	½

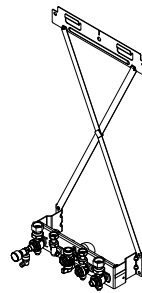

Pre-plumbing jig for surface mounting
For gas condensing combi boiler

Part no. ZK04919

Valves/fittings

Valves/fittings for surface mounting
For gas condensing system boiler

Part no. ZK04669
Part no. ZK05676

Comprising:

- Valves/fittings, heating flow/heating return
- Boiler drain & fill valve
- Air vent valve
- Pressure gauge
- Gas shut-off valve with thermally activated safety shut-off valve

Connections (male thread)		
Gas shut-off valve	G	DN 15 with G ¾ locking ring fitting
Heating flow/heating return	G	¾

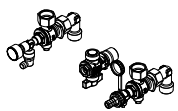

Valves/fittings for surface mounting
For gas condensing combi boiler

Part no. ZK04925
Part no. ZK04927

Comprising:

- Valves/fittings, heating flow/heating return
- Valves/fittings, cold water/DHW
- Boiler drain & fill valve
- Air vent valve
- Pressure gauge
- Gas shut-off valve with thermally activated safety shut-off valve

Connections (male thread)		
Gas shut-off valve	G	¾ DN 15 with G ¾ locking ring fitting
Heating flow/heating return	G	¾
Cold water/DHW	R	½

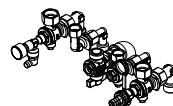

Installation accessories (cont.)

Valves/fittings for flush mounting

Part no. ZK04670

For gas condensing system boiler

Comprising:

- Valves/fittings, heating flow/heating return
- Boiler drain & fill valve
- Air vent valve
- Pressure gauge
- Gas shut-off valve with thermally activated safety shut-off valve
- Mounting plate, flush mounting

Connections (male thread)		
Gas shut-off valve	R	3/4
Heating flow/heating return	R	3/4

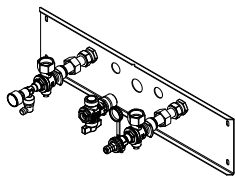

Valves/fittings for flush mounting

For gas condensing combi boiler

Part no. ZK04926

Comprising:

- Valves/fittings, heating flow/heating return
- Valves/fittings, cold water/DHW
- Boiler drain & fill valve
- Air vent valve
- Pressure gauge
- Gas shut-off valve with thermally activated safety shut-off valve
- Mounting plate, flush mounting

Mounting frame

Mounting frame

For gas condensing system boiler

Part no. ZK04308

Comprising:

- Fixings
- Valves/fittings, heating flow/heating return
- Boiler drain & fill valve
- Air vent valve
- Pressure gauge
- Gas shut-off valve with thermally activated safety shut-off valve

Wall clearance 90 mm

Connections (male thread)		
Gas shut-off valve	R	3/4
Heating flow/heating return	R	3/4

Connections (male thread)		
Gas shut-off valve	R	3/4
Heating flow/heating return	R	3/4
Cold water/DHW	R	1/2

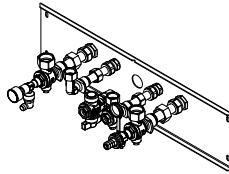

Valves/fittings for surface mounting "light version"

For gas system boilers

Part no. ZK05673

Comprising:

- Gas connection piece
- Connection pieces and angle valves

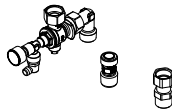

Valves/fittings for surface mounting "light version"

For gas system boilers

Part no. ZK05672

Comprising:

- Gas connection piece
- Connection pieces and angle valves

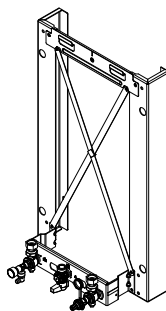

Mounting frame

For gas condensing combi boiler

Part no. ZK04922

Comprising:

- Fixings
- Valves/fittings, heating flow/heating return
- Valves/fittings, cold water/DHW
- Boiler drain & fill valve
- Air vent valve
- Pressure gauge
- Gas shut-off valve with thermally activated safety shut-off valve

Installation accessories (cont.)

Wall clearance 90 mm

Connections (male thread)		
Gas shut-off valve	R	¾
Heating flow/heating return	R	¾
Cold water/DHW	R	½

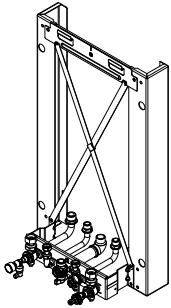

Wall spacer frame

For gas combi and system boilers

Part no. ZK06124

Comprising:

- Fixings

Wall clearance: 90 mm

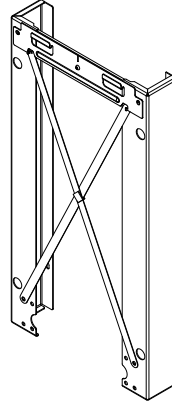

Further accessories

Hydraulic adaptor

Part no. ZK02587

For connection to on-site pipework with surface mounting

For replacing the older appliances below with the Vitodens 100-W:

- Pendola
- Vitopend (from 2004 onwards)
- Thermoblock-VC and VC 110 E/112 E
- Thermoblock-VCW
- Cerastar-ZR or Ceramini
- Cerastar-ZWR

Connection to on-site heating flow/heating return:

Connection pipes with union nuts and connection pieces Rp ¾ (female thread)

The pre-plumbing jig for surface mounting must be ordered separately.

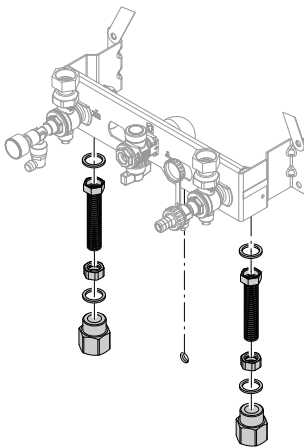

Hydraulic adaptor

Part no. ZK02588

For connection to on-site pipework with flush mounting

For replacing the older appliances below with the Vitodens 100-W:

- Pendola
- Vitopend (from 2004 onwards)
- Thermoblock-VC and VC 110 E/112 E
- Thermoblock-VCW
- Cerastar-ZR or Ceramini
- Cerastar-ZWR

Connection to on-site heating flow/heating return

Connection pipes with union nuts and connection elbows G ¾ (male thread)

The pre-plumbing jig for surface mounting must be ordered separately.

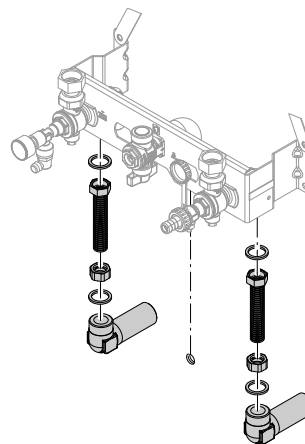

Heat meter

For installation in the connection line

Part no.	Suitable for DHW cylinders:
7172847	– Vitocell 100: Up to 500 l capacity – Vitocell 300: Up to 200 l capacity With connection accessories for G 1
7172848	– Vitocell 300: 300 to 500 l capacity With connection accessories for G 1¼

Installation accessories (cont.)

Components:

- Measuring unit with threaded connector for capturing the flow rate.
- Temperature sensor Pt1000, connected to the heat meter, sensor lead 1.5 m long.
- G 1 or G 1¼ connection accessories including ball valves.

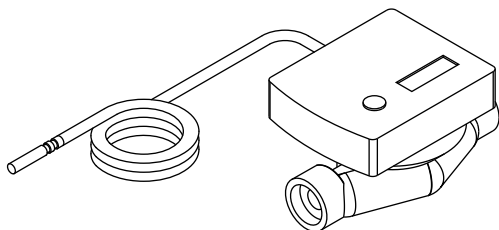

Pressure drop

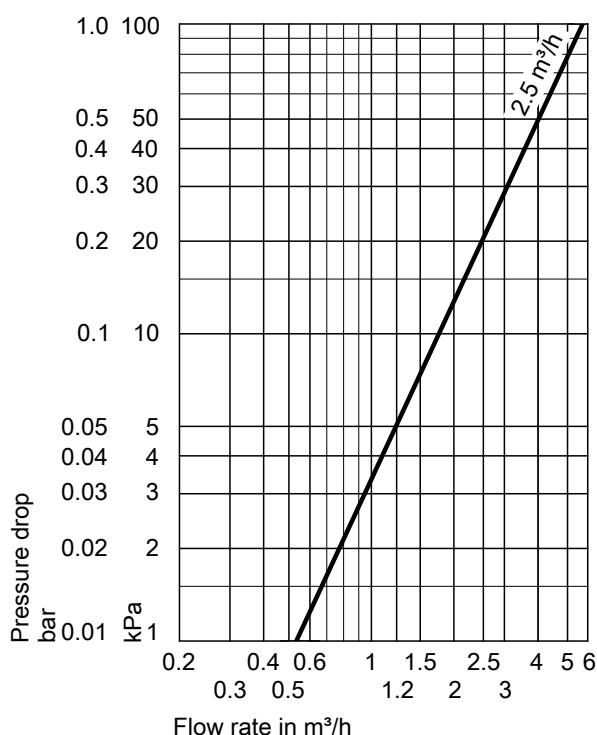

Safety assembly to DIN 1988

Comprising:

- Shut-off valve
- Non-return valve and test connector
- Pressure gauge connector
- Diaphragm safety valve
 - 10 bar (1 MPa)
 - DN 15, up to 200 l cylinder capacity
Part no. 7219722
 - DN 20, for 300 l cylinder capacity
Part no. 7180662
 - (A) 6 bar (0.6 MPa)
 - DN 15, up to 200 l cylinder capacity
Part no. 7265023
 - DN 20, for 300 l cylinder capacity
Part no. 7179666

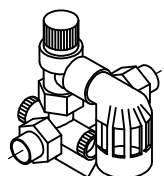

For Vitocell 100-W below the boiler

- 10 bar (1 MPa), DN 15, right angle version
Part no. 7180097
- (A) 6 bar (0.6 MPa), DN 15, right angle version
Part no. 7179457

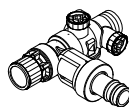

Pressure reducer (DN 15)

Part no. 7180148

To match right angle version of the safety assembly

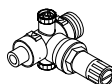

Specification

Nominal flow rate	2.5 m³/h
Lead length	1.5 m
IP rating	IP 54 to EN 60529; ensure through design/installation
Permissible ambient temperature	
– During operation	5 to 55 °C
– During storage and transport	–20 to +70 °C
Sensor type	Pt1000
Max. operating pressure	10 bar (1 MPa)
Nominal diameter	DN 20
Installed length	130 mm
Max. flow rate	5000 l/h
Minimum flow rate	
– Horizontal installation	50 l/h
– Vertical installation	50 l/h
Start-up value (for horizontal installation)	7 l/h
Battery life	Approx. 10 years

Drain outlet set

Part no. 7459591

Drain outlet with trap and rose. For connecting the drain lines of the safety valves and the condensate drain.

Drain connection G 1

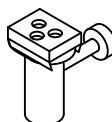

Valve/fitting cover

Part no. ZK06090

Cannot be used in conjunction with a DHW cylinder below the boiler

Installation accessories (cont.)

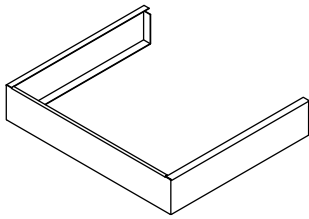

Neutralising system with wall mounting bracket

Part no. ZK03652

With neutralising granulate

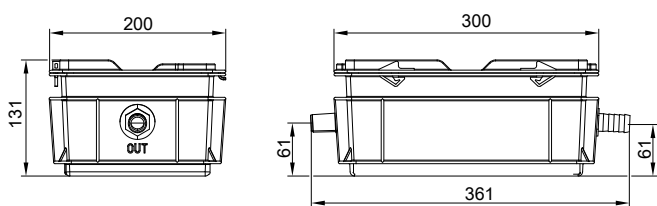

Neutralising granulate

Part no. ZK03654

2.5 kg

To match the neutralising system, part no. ZK03652

Condensate lifting system

Part no. ZK02486

Automatic condensate removal pump for condensate with a pH value of ≥ 2.8 from gas condensing boilers

Components:

- Condensate container 2.0 l
- Centrifugal pump
- Non-return valve
- Connecting cable (1.5 m long) for fault messages
- Power cable (1.5 m long) with plug
- 4 connection apertures \varnothing 30 mm for condensate drain with connector \varnothing max. 40 mm)
- Drain hose \varnothing 10 mm (5 m long)

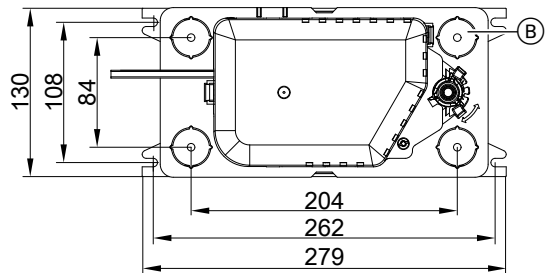
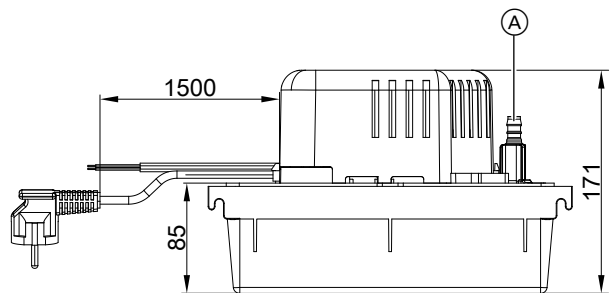

- Ⓐ Condensate drain
- Ⓑ 4 x condensate inlet (closed in delivered condition)

Specification

Rated voltage	230 V~
Rated frequency	50 Hz
Power consumption	70 W
IP rating	IP 20
Permissible medium temperature	+65 °C
Max. head	50 kPa
Max. pump rate	500 l/h
Alarm contact	Changeover contact (floating), breaking capacity 250 V/4 A

Water spray protection

Part no. 7590109

To ensure adherence to the required protection class. Must be ordered separately for open flue operation.

Small softening system for heating water

For filling heating circuits

See Vitoset pricelist

Tool kit

Part no.: ZK04569

For maintenance and service

Case with all tools required for maintenance and service: Screwdriver, extension and inserts

Connections between the Vitodens and the DHW cylinder

Connection set for Vitocell 100-W DHW cylinder, type CUGA-A below the boiler, with connection pipes

Part no. ZK04709

Comprising:

- Cylinder temperature sensor
- Connection pipes on the heating water side
- Connection pipes on the DHW side

Installation accessories (cont.)

Surface or flush mounting

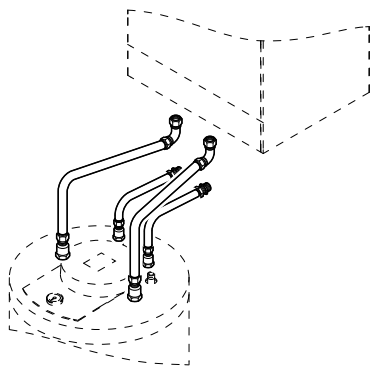

Connection set for Vitocell 100-W DHW cylinder adjacent to the boiler

Comprising:

- Cylinder temperature sensor
- Connection fittings

DHW cylinder to the **left or right** of the Vitodens

- Threaded fitting version

Part no. ZK04710

- Solder version

Part no. ZK04711

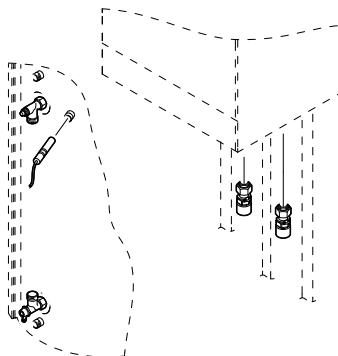

4.2 Installation accessories for Vitodens 100-W

Neutralising system with wall mounting bracket

Part no. ZK03652
With neutralising granulate

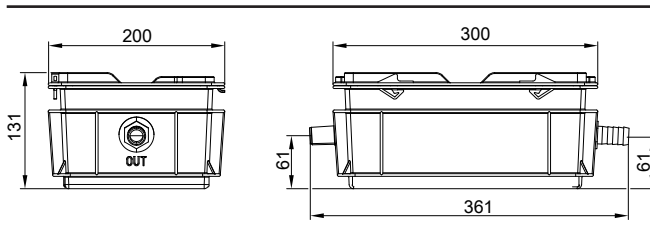

Neutralising granulate

Part no. ZK03654
2.5 kg

To match the neutralising system, part no. ZK03652

Tool kit

Part no.: ZK04569
For maintenance and service
Case with all tools required for maintenance and service: Screwdriver, extension and inserts

Cylinder demand junction box

Part no.: 7296968
For operation with a cylinder temperature sensor (230 V)

Design information

5.1 Siting, installation

Siting conditions for open flue operation (appliance type B)

Type B₂₃ and B₃₃

In rooms where **air contamination from halogenated hydrocarbons or organosilicon compounds (e.g. siloxanes)** may occur, such as hairdressing salons, printing shops, dry cleaners, laboratories, etc., the Vitodens may only be operated as a room sealed system.

If in doubt, please consult us.

Never install the Vitodens in areas subject to very dusty conditions. The installation location must be kept free from frost and must be adequately ventilated.

Provide a condensate drain and a discharge pipe for the safety valve in the installation room.

The max. ambient temperature of the system must not exceed 40 °C.

If these instructions are not observed, any consequential appliance damage directly related to any of these causes is excluded from our warranty.

Multi boiler systems with flue systems under negative pressure

Systems with several Vitodens with separate hydraulic connections require a flue gas cascade suitable for negative pressure or individual flue gas routing for each boiler.

Installation room

Permissible:

- Siting gas equipment on the same floor
- Living space with interconnected room air supply
- Ancillary rooms with interconnected room air supply (larders, basements, utility rooms, etc.)
- Ancillary rooms with vents to the outside: Ventilation air/extract air 150 cm² or 2 × 75 cm² each at the top and bottom of the same wall, up to 35 kW
- Attic rooms, but only with adequate minimum chimney height to DIN 18160 – 4 m above inlet (negative pressure operation).

Not permissible:

- Stairwells and communal hallways. Exception: In detached and two-family houses of low height: Top edge of floor in the top storey < 7 m above ground level
- Bathrooms without outside windows with shaft ventilation
- Rooms where explosive or flammable materials are stored.
- Rooms that are ventilated mechanically or via individual duct systems to DIN 18117-1

Observe all local fire regulations.

Connection on the flue gas side

The connection piece to the chimney should be as short as possible. Therefore position the Vitodens as close to the chimney as possible. The flue should be designed to be as straight as possible. If bends are unavoidable, do not arrange these directly one after another. It must be possible to test and clean the entire flue gas path as required.

No special protective measures or clearances towards combustible objects, such as furniture, packaging or similar, need to be taken/observed. The surface temperatures of the Vitodens and the flue system do not exceed 85 °C at any point.

For further details, see the technical guide on flue systems for the Vitodens.

Extractors

Operating appliances that extract air to the outside (extractor hoods, extractors, air conditioning units, etc.) can create negative pressure. If the boiler is operated at the same time, this can lead to a reverse flow of **flue gas**, which can cause life threatening poisoning.

To prevent the reverse flow of flue gas, fit an **interlock circuit** or take suitable steps to ensure an adequate supply of combustion air.

Safety equipment for the installation room

Viessmann heat generators are tested and approved in accordance with all safety regulations and are therefore fail-safe. Unpredictable external factors may, in the rarest of cases, lead to the potentially harmful escape of carbon monoxide (CO). For this case, we recommend using a CO limiter.

Siting conditions for room sealed operation (appliance type C)

Type C_{10(3)x}, C_{11(3)x}, C_{13(3)x} or C_{14(3)x} to TRGI 2018

The Vitodens can be installed for **room sealed** operation **independent** of the size and ventilation of the installation room.

Installation room

Suitable siting locations include:

- Recreational rooms and other living spaces
- Unventilated ancillary rooms
- Cabinets (open at the top)
- Recesses without compulsory clearance towards combustible materials
- Attic rooms (pitched attics and long panes) where the balanced flue pipe can be routed directly through the roof

The installation room must be free from the risk of frost.

The max. ambient temperature of the system must not exceed 40 °C.

Provide a condensate drain and a discharge pipe for the safety valve in the installation room.

Electrical interlocks for extractors (extractor hoods, etc.) are not required with room sealed operation.

Connection on the flue gas side

The flue should be designed as short and straight as possible. If bends are unavoidable, do not install them directly one after another. It must be possible to test and clean the entire flue gas path as required.

Since the flue pipe connection for room sealed operation is surrounded by combustion air (coaxial pipe), maintaining clearances towards combustible components is not required.

Ventilation air ducts with which oil or solid fuel boilers were previously used must not contain any sulphur or soot deposits on the inner surfaces.

Sulphur and soot deposits cause operating faults.

If thorough cleaning is not possible, a balanced flue pipe must be laid through the shaft. Alternatively, lay separate ventilation air and flue gas pipes.

Viessmann accepts no liability for damages resulting from failure to observe these instructions.

Close off and seal any other connection apertures with appropriate materials.

This does not apply to any cleaning or inspection apertures that are provided with chimney cleaning covers and that are identified with an appropriate test mark.

For further details, see the technical guide on flue systems for the Vitodens.

Use of third party flue systems of type C₆₃/C_{63x}

Any approved flue system can be used for type C₆₃/C_{63x}. A system test of these flue systems with Viessmann heat generators has not been carried out, so there is no system certification in accordance with Gas Appliances Regulation (EU) 2016/426.

When implementing type C₆₃/C_{63x} with Viessmann heat generators, the following specifications must be observed and complied with:

- Viessmann design specifications for types C_{13x}, C_{14(3)x}, C_{33x}, C_{53x}, C_{83x} and C_{93x}
- Appliance-specific details of Viessmann heat generators, e.g. max. draughts, flue gas temperatures, mass flow rates, boiler flue connection tolerances

- Reverse flow of flue gas at the terminal of the flue system, even when it is windy: ≤ 10 %
- Wind protection devices for the supply of combustion air and the discharge of flue gas must not be installed on opposite walls of the building.

Flue pipes

- Flues made from plastic (PPS):

Measures inside the equipment ensure that the flue gas temperature of 120 °C will never be exceeded. Flues made from plastic (PPS) with an approval for flue gas temperatures up to a maximum of 120 °C (type B) can therefore be used.

- Flues made from aluminium:

Aluminium residues in the condensate can impair the function of the heat generator. A condensate trap must therefore be additionally installed above the boiler flue connection. The condensate trap must allow the condensate returned from the flue system to completely bypass the heat generator.

Dimensions of boiler flue gas connection

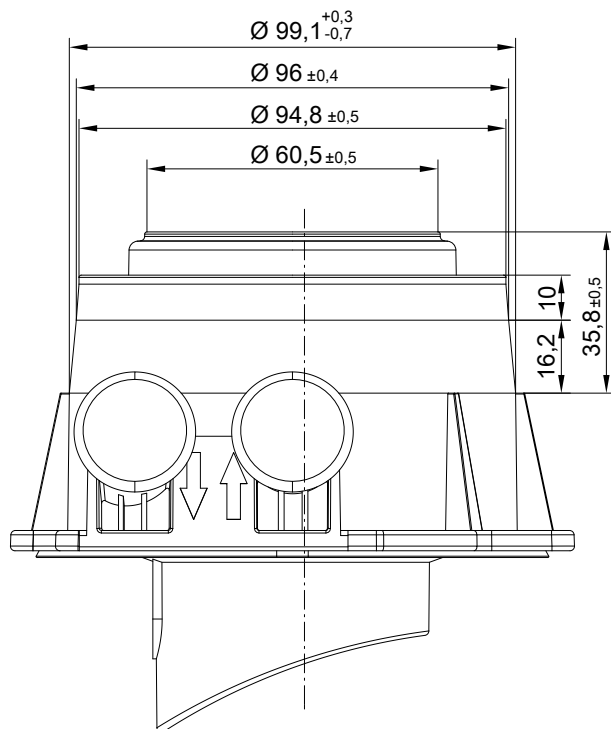

Safety equipment for the installation room

Viessmann heat generators are tested and approved in accordance with all safety regulations and are therefore fail-safe. Unpredictable external factors may, in the rarest of cases, lead to the potentially harmful escape of carbon monoxide (CO). For this case, we recommend using a CO limiter.

Design information (cont.)

Operation of the Vitodens in wet rooms

Room sealed operation

- The Vitodens is approved for installation in wet rooms.
- Vitodens 050-W, Vitodens 100-W: Protection rating IP X4 splash-proof
The boiler may be installed in safety zone 1 if hosed water (e.g. from massage showers) is prevented.

Open flue operation

- Vitodens 050-W, Vitodens 100-W may only be installed in safety zone 1 or 2 if additional splash protection (part no. 7590109) is fitted.
- These systems must not be installed in safety zones 1 or 2.

When installing the Vitodens in wet rooms, observe the safety zones and minimum wall clearances according to VDE 0100 [or local regulations]: (See chapter "Electrical safety zone").

Electrical safety zone

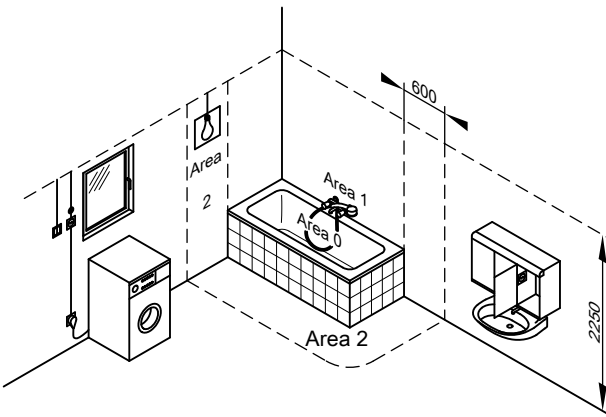

Electrical connection

The power supply must comply with the requirements of the local power supply utility and current VDE [or local] regulations!
The power supply must comply with the requirements of the local power supply utility and current ÖVE [or local] regulations!
Protect the power cable with a fuse with a max. rating of 16 A.
We recommend installing an AC/DC-sensitive RCD (RCD class B) for DC (fault) currents that can occur with energy efficient equipment.
Make the power supply (230 V~, 50 Hz) via a permanent connection.
Flexible connecting cable included in standard delivery:

Recommended cables

Flexible connecting cable max. 3 x 1.5 mm²

- Power cables (accessories)
- DHW circulation pump

Approx. 2 m long

It can be connected via an on-site junction box outside the appliance.

The power supply for the accessories is connected at the terminals in the appliance. The cables are inserted into the boiler through the underside.

Outside temperature sensor, cylinder temperature sensor are connected to an external plug:

Plug on the underside

Flexible 2-core connecting cable min. 0.75 mm²

Outside temperature sensor

Gas connection

Gas installations must only be carried out by a registered gas fitter authorised by the relevant gas supply utility.
Connect and size the mains gas according to TRGI 2018 or TRF 2012 [or local regulations].
Connect the mains gas according to ÖVGW-TR Gas (G1) and the regionally applicable building regulations.
Max. test pressure 150 mbar (15 kPa).
We recommend installing a gas filter to DIN 3386 in the gas line.

Thermally activated safety shut-off valve

According to paragraph 4, section 5 of the FeuVo 2008 [check local fire regulations], thermally activated shut-off equipment must be installed in combustion equipment or in gas supply lines immediately upstream of the combustion equipment. This equipment must shut off the gas supply if the external temperature exceeds 100 °C. The valves must isolate the gas supply for at least 30 min up to a temperature of 650 °C. This is intended to prevent the formation of explosive gas mixtures in the event of a fire.

The gas shut-off valves supplied with the Vitodens are equipped with integral, thermally activated safety shut-off valves.

Design information (cont.)

Gas connection line

Calculate the size of the on-site gas connection line using the gas supply values (specification).

Minimum clearances

Clearance for maintenance work and operating the ON/OFF switch:

- 700 mm in front of the boiler
- No clearance required to the left or right of the boiler

Installation of the Vitodens 050-W

Accessories required in addition to installation with the pre-plumbing jig, valves/fittings or mounting frame:

Installation without DHW cylinder: Caps for cylinder flow and return

Installation with DHW cylinder: Connection set for DHW cylinder

Design information (cont.)

Pre-plumbing jig for surface mounting

With fixings, valves/fittings and gas shut-off valve R ¾ with integral, thermally activated safety shut-off valve

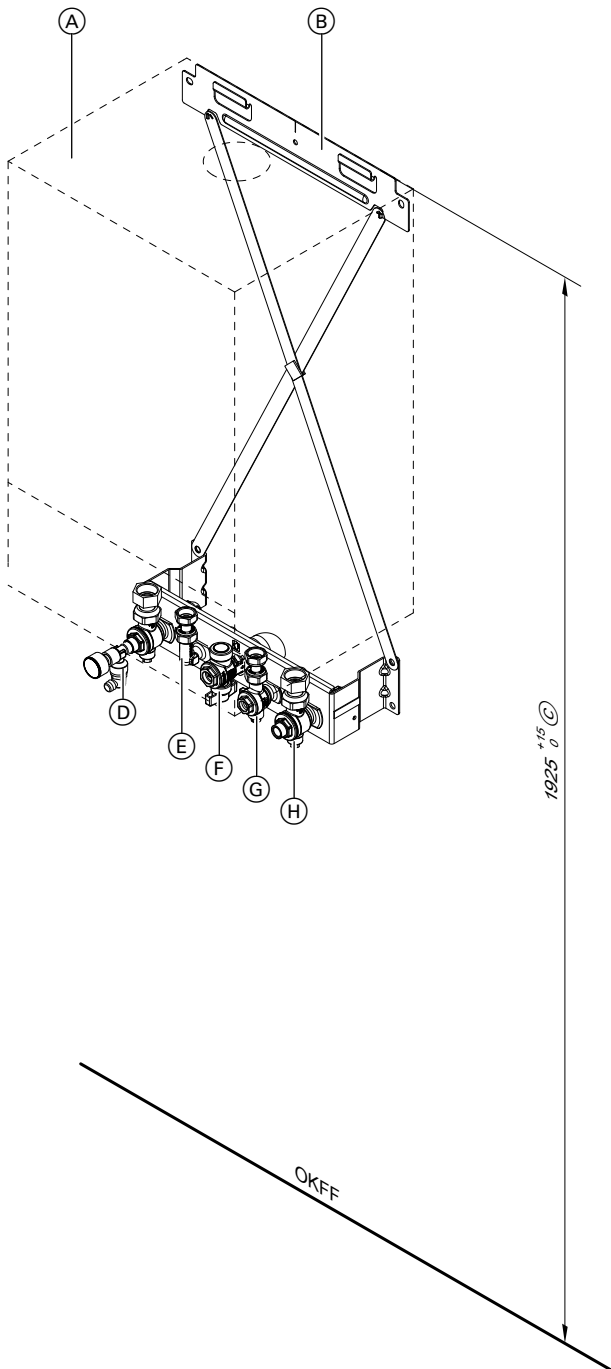

Illustration shows a gas condensing combi boiler

- | | | | |
|-----|--|------|---|
| (A) | Vitodens | (E) | Cold water R ½ |
| (B) | Pre-plumbing jig | (F) | Gas connection R ¾ |
| (C) | Compulsory in conjunction with DHW cylinders below the boiler, otherwise recommendation only | (G) | DHW R ½ |
| (D) | Heating flow R ¾ with pressure gauge and air vent valve | (H) | Heating return R ¾ with boiler drain & fill valve |
| | | OKFF | Top edge, finished floor |

Design information (cont.)

Valves/fittings for surface mounting

With valves/fittings and gas shut-off valve R ¾ with integral, thermally activated safety shut-off valve

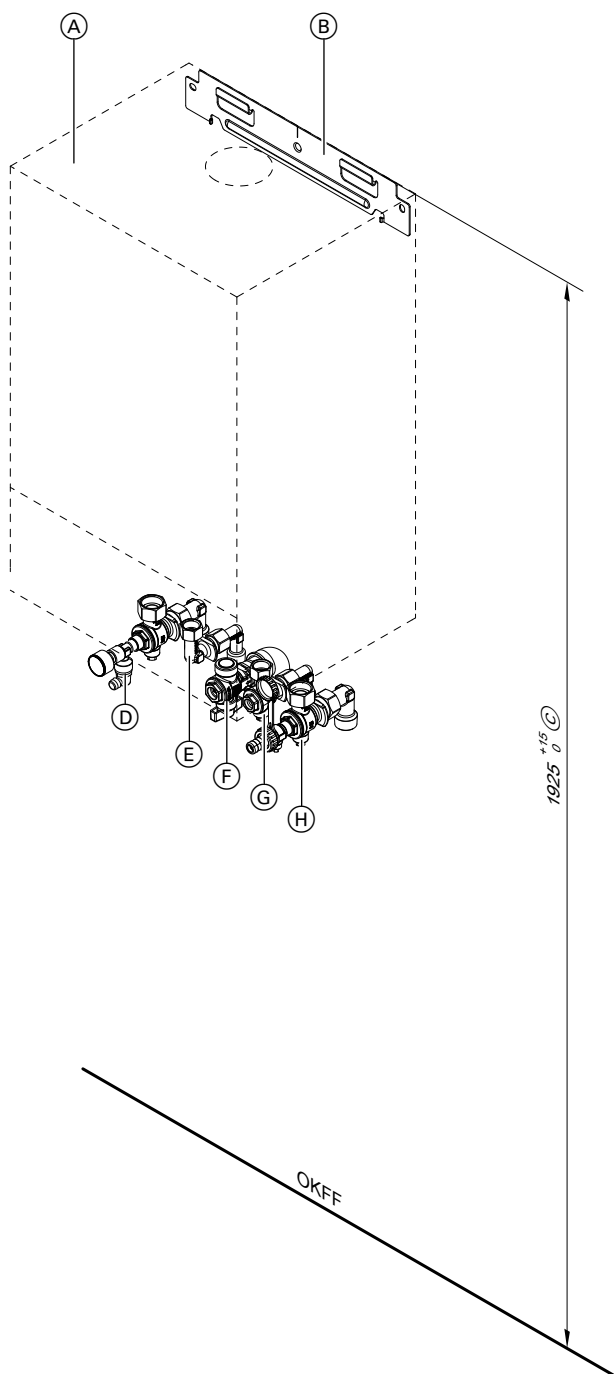

Illustration shows a gas condensing combi boiler

- | | | | |
|-----|--|------|---|
| (A) | Vitodens | (E) | Cold water R ½ |
| (B) | Pre-plumbing jig | (F) | Gas connection R ¾ |
| (C) | Compulsory in conjunction with DHW cylinders below the boiler, otherwise recommendation only | (G) | DHW R ½ |
| (D) | Heating flow R ¾ with pressure gauge and air vent valve | (H) | Heating return R ¾ with boiler drain & fill valve |
| | | OKFF | Top edge, finished floor |

Design information (cont.)

Valves/fittings for flush mounting

With valves/fittings and gas shut-off valve R $\frac{3}{4}$ with integral, thermally activated safety shut-off valve and mounting plate

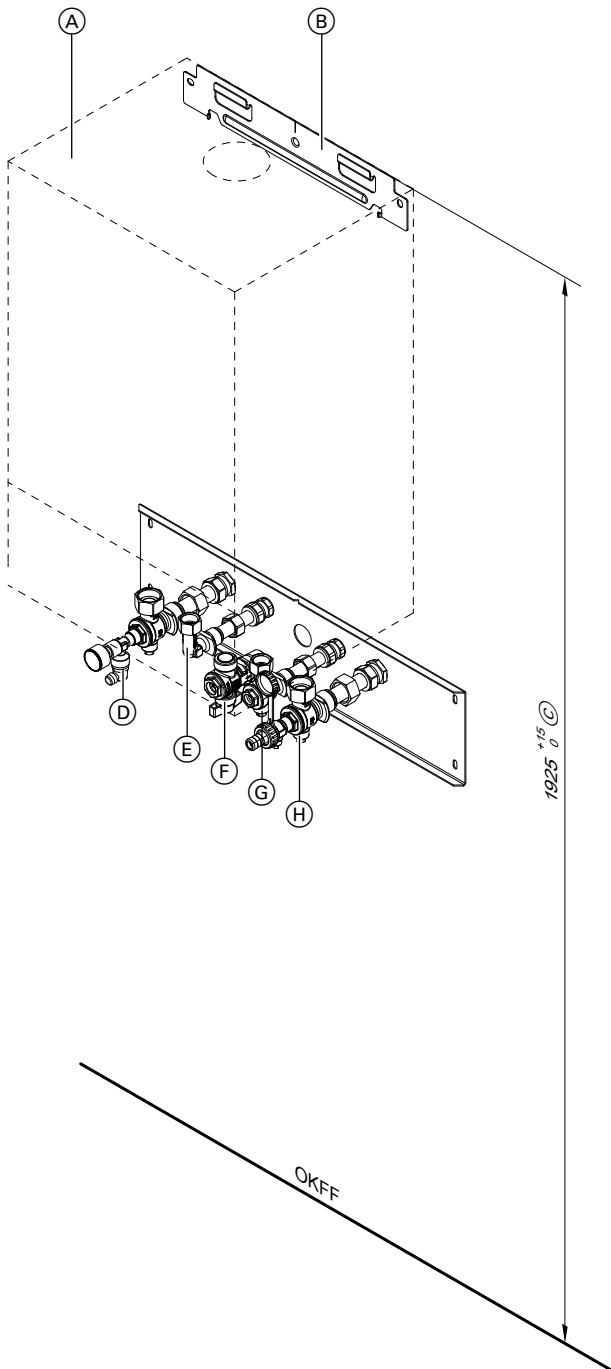

Illustration shows a gas condensing combi boiler

- | | | | |
|-----|--|------|---|
| (A) | Vitodens | (E) | Cold water R $\frac{1}{2}$ |
| (B) | Pre-plumbing jig | (F) | Gas connection R $\frac{3}{4}$ |
| (C) | Compulsory in conjunction with DHW cylinders below the boiler, otherwise recommendation only | (G) | DHW R $\frac{1}{2}$ |
| (D) | Heating flow R $\frac{3}{4}$ with pressure gauge and air vent valve | (H) | Heating return R $\frac{3}{4}$ with boiler drain & fill valve |
| | | OKFF | Top edge, finished floor |

Design information (cont.)

Mounting frame for surface mounting

With fixings, valves/fittings and gas shut-off valve R ¾ with integral, thermally activated safety shut-off valve

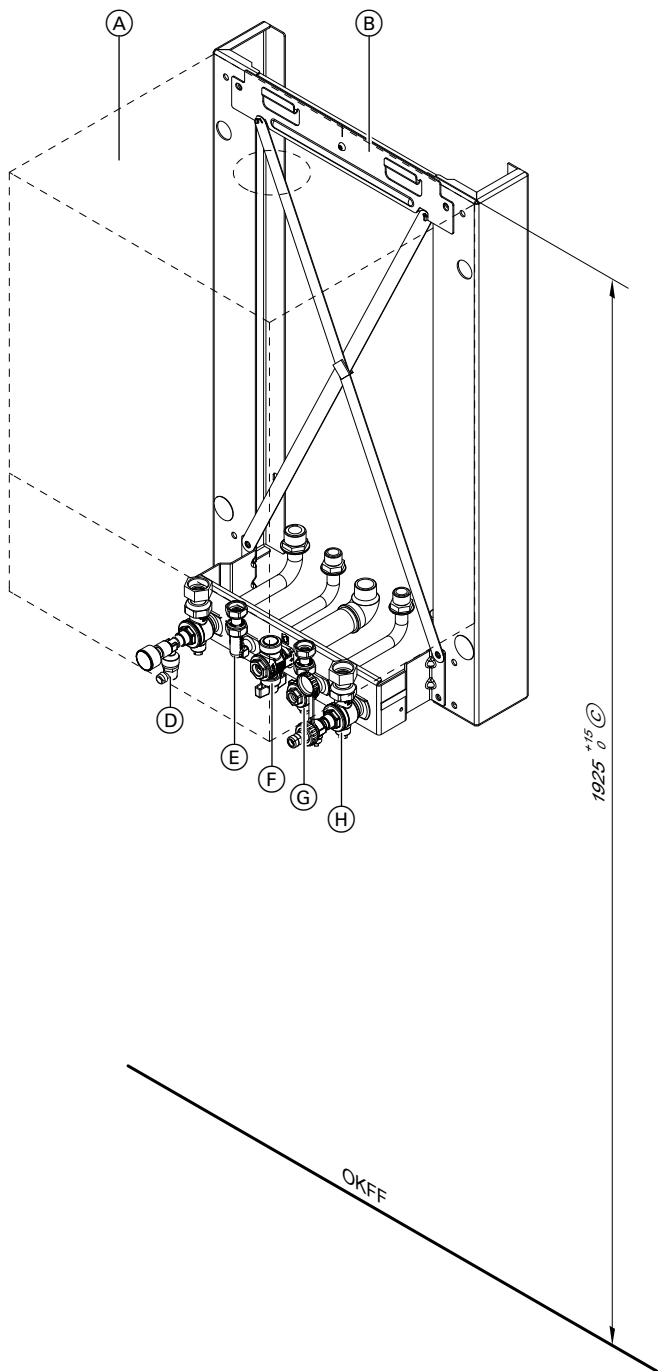

Illustration shows a gas condensing combi boiler

- | | | | |
|---|--|------|---|
| Ⓐ | Vitodens | Ⓔ | Cold water R ½ |
| Ⓑ | Mounting frame | Ⓕ | Gas connection R ¾ |
| Ⓒ | Compulsory in conjunction with DHW cylinders below the boiler, otherwise recommendation only | Ⓖ | DHW R ½ |
| Ⓓ | Heating flow R ¾ with pressure gauge and air vent valve | Ⓗ | Heating return R ¾ with boiler drain & fill valve |
| | | OKFF | Top edge, finished floor |

Design information (cont.)

Replacing third party boilers with the Vitodens 050-W

Using an adaptor, the Vitodens hydraulic connections are compatible with Ceramini-Z-SR, Cerastar-ZR/-ZWR and Thermoblock-VC110E-/VC112E/-VC/-VCW boilers.

For modernisation projects, adaptors are available as accessories (see pricelist). These comprise connection components for the heating water and DHW sides and fixings for replacing the third party appliances listed below with a Vitodens. A pre-plumbing jig for surface mounting or valves/fittings for surface mounting must be ordered separately in addition to the Vitodens 050-W.

The installation work involved is no greater than replacement with a same-brand appliance.

Where a wall mounted gas boiler is replaced by a Vitodens 050-W gas condensing system boiler, the flue must also be replaced with a system that is "suitable for condensing operation" (see pricelist "Flue systems for the Vitodens").

Adapt the flue connections on site.

Note

For modernisation projects, the State Building Regulations [Germany] require the on-site installation of a gas shut-off valve with thermally activated shut-off facility.

Replacing a Ceramini-Z-SR with a Vitodens 050-W, 11 kW and 19 kW

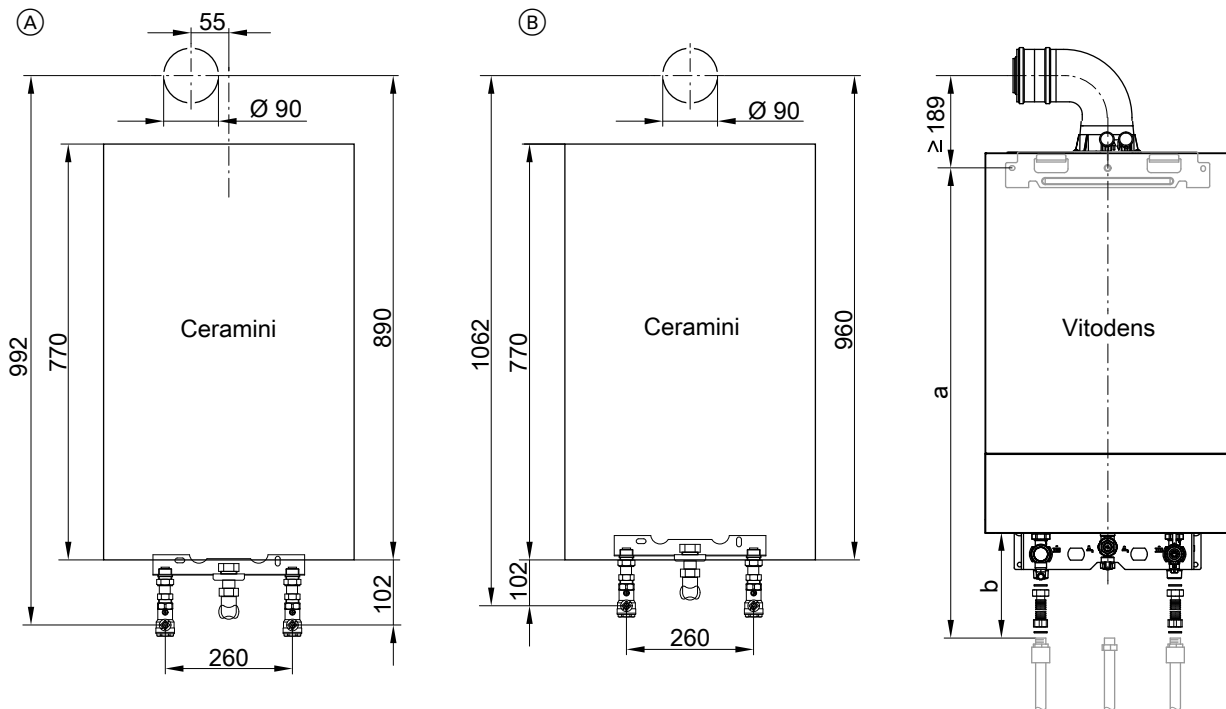

- (A) Open flue operation
- (B) Room sealed operation

Dim.	Flush mounting	Surface mounting
a mm	790 +25/-0	802 +50/-0

Note

Height of flue gas connection in combination with balanced flue bend 60/100. If using a balanced flue inspection bend 60/100, the height is reduced by 10 mm.

Design information (cont.)

Replacing a Cerastar-ZR/-ZWR with a Vitodens 050-W, 25 and 32 kW

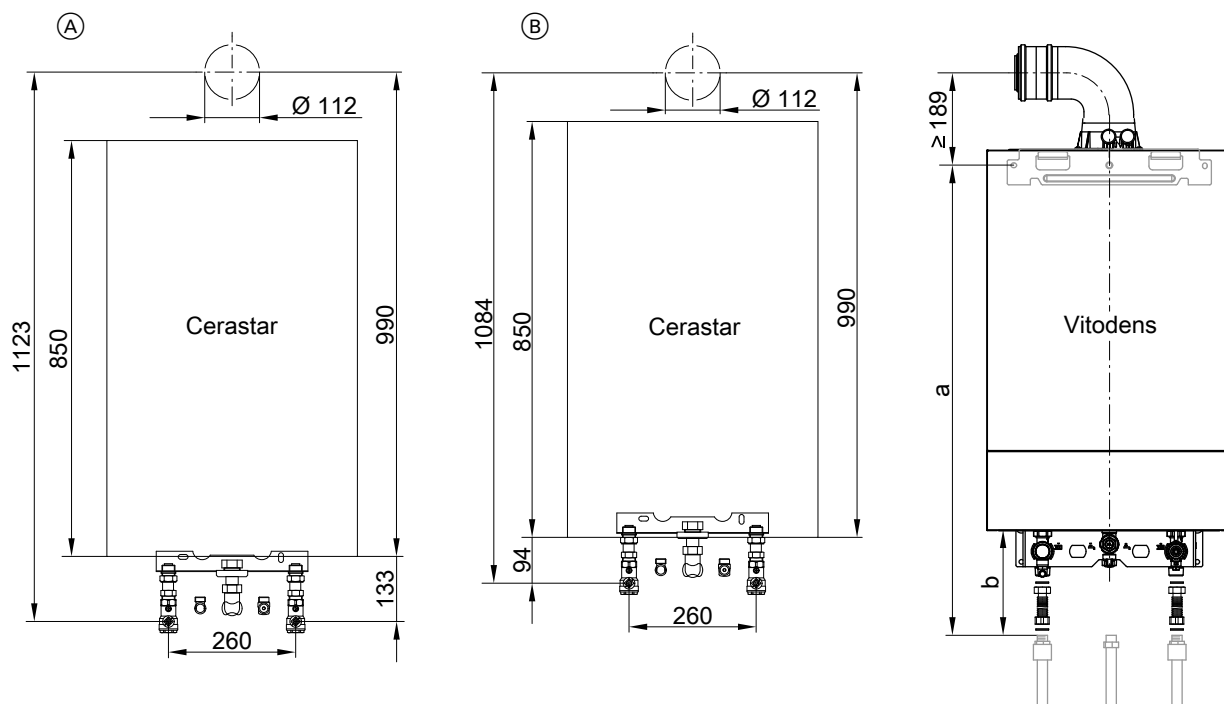

- (A) Open flue operation
- (B) Room sealed operation

Dim.	Flush mounting	Surface mounting
a mm	790 +25/-0	802 +50/-0

Note

Height of flue gas connection in combination with balanced flue bend 60/100. If using a balanced flue inspection bend 60/100, the height is reduced by 10 mm.

Design information (cont.)

Replacing a Thermoblock-VC110E/-VC112E with a Vitodens 050-W, 11 and 19 kW

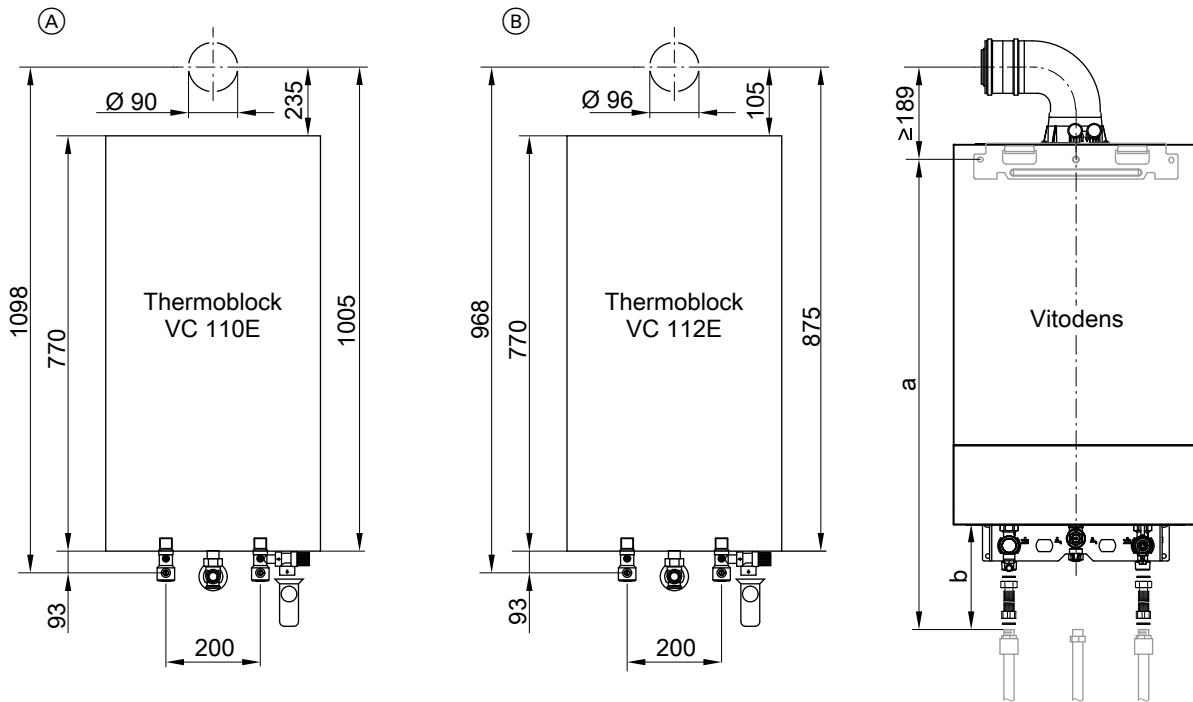

- (A) Open flue operation
- (B) Room sealed operation

Dim.	Flush mounting	Surface mounting
a mm	786 +25/-0	802 +50/-0

Note

Height of flue gas connection in combination with balanced flue bend 60/100. If using a balanced flue inspection bend 60/100, the height is reduced by 10 mm.

Design information (cont.)

Replacing a Thermoblock-VC/-VCW with a Vitodens 050-W, 25 and 32 kW

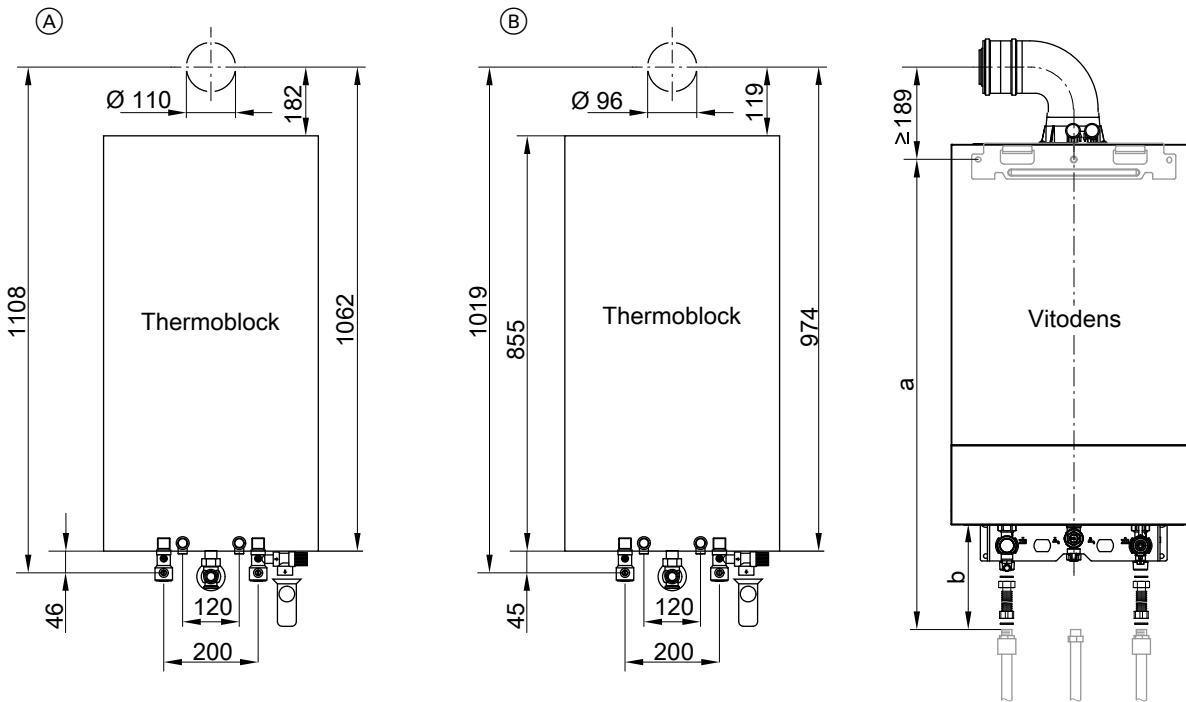

- (A) Open flue operation
- (B) Room sealed operation

Dim.	Flush mounting	Surface mounting
a mm	786 +25/-0	802 +50/-0

Note

Height of flue gas connection in combination with balanced flue bend 60/100. If using a balanced flue inspection bend 60/100, the height is reduced by 10 mm.

5.2 Connections on the water side

Connection on the DHW side

Vitodens 050-W gas condensing combi boiler

For the DHW connection, connection sets for surface or flush mounting are available as accessories. The instantaneous water heater provides direct DHW heating.

If used in conjunction with galvanised pipes, note that the instantaneous water heater is designed as a stainless steel plate heat exchanger with copper solder joints (observe the flow rule).

In existing installations (modernisation projects), the risk of electrolytic corrosion is low, since a protective layer will have formed on the inside of the pipes.

If DHW is to be drawn simultaneously from several points, we recommend the installation of a separate DHW cylinder in conjunction with the gas system boiler (see "Selection guide for DHW heating"). With water hardness of 20 °dH and higher, we recommend the use of a water treatment system in the cold water line when heating DHW.

Design information (cont.)

Cold water installation of Vitodens 050-W gas condensing combi boiler

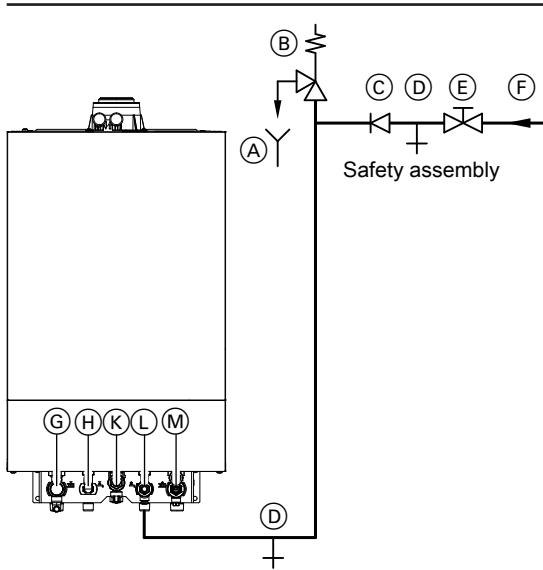

- (C) Non-return valve
- (D) Drain
- (E) Shut-off valve
- (F) Cold water
- (G) Heating flow
- (H) DHW
- (K) Gas connection
- (L) Cold water
- (M) Heating return

A safety valve to DIN 1988 is only required if the mains water supply pressure exceeds 10 bar (1 MPa) and no DHW pressure reducing valve is installed (to DIN 4753).

OT: A safety valve to DIN 1988 is only required if the mains water supply pressure exceeds 6 bar (0.6 MPa) and no DHW pressure reducing valve is installed (to DIN 4753).

Install a safety valve if the cold water inlet is equipped with a non-return valve. In addition remove the toggle from the cold water shut-off valve.

Non-return valves are commonly found in pressure reducers and combined shut-off and non-return valves.

- (A) Visible drain pipe outlet point
- (B) Safety valve

Shock arrestors

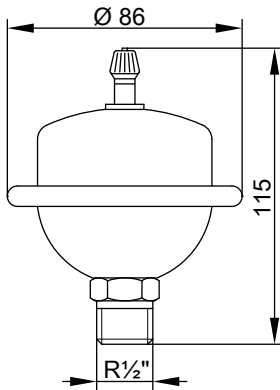

If the pipework to which the Vitodens is connected also supplies draw-off points at which water hammers may occur (e.g. pressure washers, washing machines or dishwashers): Install shock arrestors near the source of the water hammer (recommended).

Flexofit S made by Flamco-Flexcon

or

Reflex made by Winkelmann + Pannhoff GmbH (available from your local dealer).

Safety valve

The safety valve **must** be installed.

We recommend you install the safety valve higher than the top edge of the cylinder. This protects the valve against contamination, scaling and high temperatures. It also means that the DHW cylinder does not need to be drained when working on the safety valve.

Drinking water filter

Install a drinking water filter in accordance with DIN 1988-200.

DHW circulation

DHW circulation pipes increase DHW convenience and reduce water consumption. These benefits result from the immediate availability of DHW at the tap/draw-off point.

However, poor thermal insulation of the DHW circulation pipe can lead to substantial heat losses.

From a **pipe length of 7 m** upwards, we recommend the installation of a DHW circulation pipe with appropriate thermal insulation in accordance with the Energy Saving Ordinance [Germany]. The Energy Saving Ordinance specifies that the DHW circulation pipe should include a circulation pump, check valve and time switch for stopping DHW circulation during the night.

Power supply for DHW circulation pump

DHW circulation pumps equipped with their own internal control unit must be connected via a separate power supply. Connecting the power supply via the heat generator control unit or its accessories is not permissible.

Using a non-return valve

If using a DHW cylinder adjacent to the boiler, we recommend installing a non-return valve in the heating water connection line to prevent the DHW cylinder cooling due to any recirculation that may occur.

Design information (cont.)

Vitodens 050-W

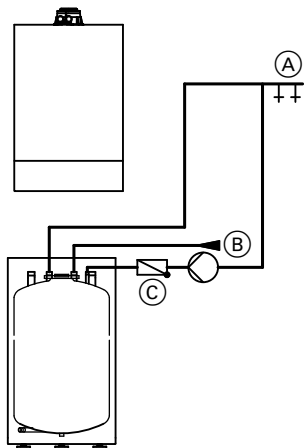

DHW cylinder below the boiler

- (A) DHW
- (B) Cold water
- (C) DHW circulation

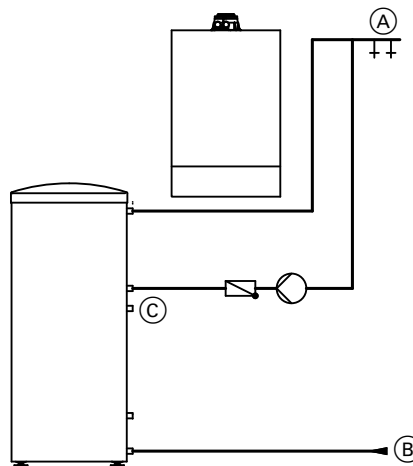

DHW cylinder adjacent to the boiler

- (A) DHW
- (B) Cold water
- (C) DHW circulation

5.3 Condensate connection

Route the condensate pipe with a constant fall. Route the condensate from the flue system together with the boiler condensate directly or via a neutralising system (if installed – accessories) to the public waste water system.

Vitodens 050-W

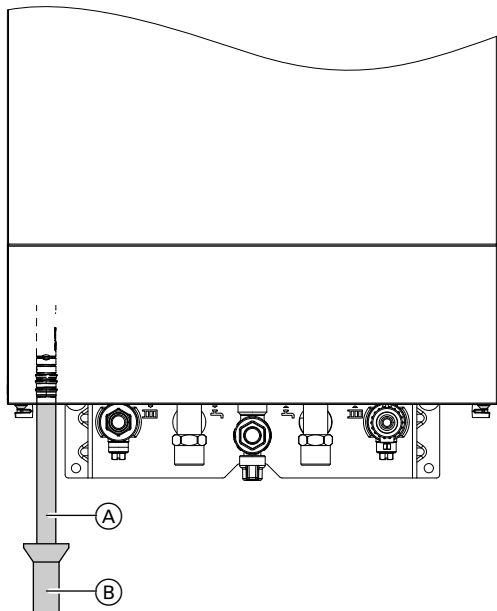

- (A) Drain hose (Vitodens standard delivery)
- (B) Drain outlet kit (accessories)

Note

A pipe vent **must** be installed between the trap and the neutralising system.

Vitodens 100-W

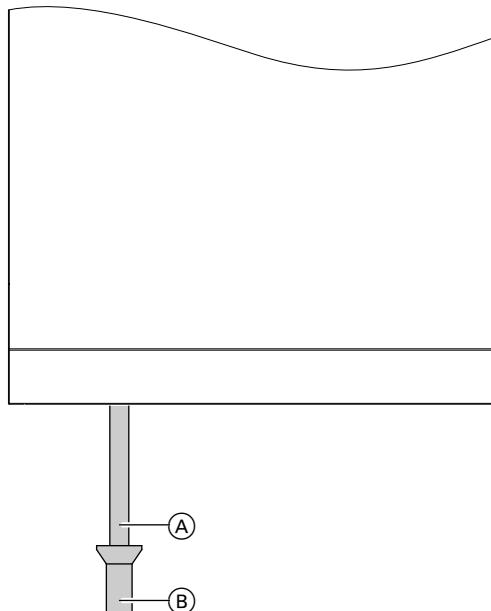

- (A) Drain hose (Vitodens standard delivery)
- (B) Drain outlet kit (accessories)

Condensate drain pipe and neutralisation

During heating operation, condensate with pH values between 4 and 5 is formed in the condensing boiler and in the flue.

The condensate should be drained in accordance with appropriate regulations.

Design information (cont.)

Code of Practice DWA-A 251 on "Condensate from condensing boilers", which is generally based on the local waste water regulations [in Germany], determines conditions for draining condensate from condensing boilers into the public sewer system.

The composition of condensate drained from Vitodens condensing boilers meets the requirements specified in Code of Practice DWA-A 251.

The condensate drain pipe to the sewer connection must be freely accessible for inspection.

It must be installed with a continuous fall and must contain a stench trap.

Also provide a suitable facility for sampling.

Condensate drain pipes may only be made from corrosion-resistant materials (e.g. reinforced hose).

Never use any zinc-plated materials or those containing copper for pipes, connection pieces, etc.

A trap is installed in the condensate drain to prevent flue gases escaping.

Local water regulations and/or specific technical circumstances may prescribe designs that vary from those described in the above Codes of Practice.

Contact your local authority responsible for waste water management in good time prior to installation, to find out about local regulations.

Condensate from gas combustion equipment up to 200 kW combustion output

Up to a rated heating output of 200 kW, the condensate from a gas condensing boiler can generally be introduced into the public waste water system without prior neutralisation.

Domestic drainage systems must be made from materials that are resistant to acidic condensate.

According to the Code of Practice DWA-A 251, these materials include:

- Vitrified clay pipes
- Hard PVC pipes
- PVC pipes
- PE HD pipes
- PE pipes
- ABS/ASA pipes
- Stainless steel pipes
- Borosilicate pipes

5.4 Hydraulic connection

General

System design

Viessmann condensing boilers can generally be installed in any fully pumped hot water heating system (sealed unvented system).

The circulation pump is an integral part of the appliance.

Minimum system pressure 1.0 bar (0.1 MPa).

The boiler water temperature is limited to 82 °C.

To minimise distribution losses, we recommend sizing the heat distribution system to a max. flow temperature of 70 °C.

Due to the immediate capture of the room influence factors, we recommend using the Vitodens in conjunction with the Vitotrol 200-E for apartments with less than 80 m² living space or for low energy houses with a low heat demand.

The heat generator must be correctly sized and selected.

Chemical anti-corrosion agents

According to VDI guideline 2035, the design of heating systems must ensure they are sealed against corrosion. Additives in the heating water (additives, chemicals) as corrosion protection measures are normally not necessary.

Exception: In systems without system separation, for example, additives can be considered.

Neutralising system

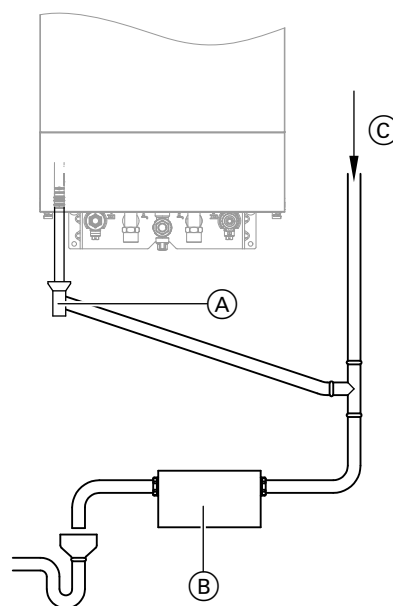

- (A) Condensate drain
- (B) Neutralising system
- (C) Ventilation via the roof

The Vitodens can (if required) be supplied with a separate neutralising system (accessories). Any condensate is piped to and processed in the neutralising system. Since the consumption of neutralising granulate depends on the system's operating mode, carry out regular checks during the first year of operation to determine the required top-up volumes. One fill can last longer than one year.

The condensate drain pipe to the sewer connection must be accessible for inspection. Install it with a fall and a stench trap on the sewer side, and provide a suitable facility for extracting samples.

Install a condensate lifting pump if the Vitodens has been installed below the waste water anti-flooding level. Condensate lifting pumps are available as accessories.

Heating circuits

For heating systems with plastic pipes, we recommend the use of impermeable pipes to prevent the diffusion of oxygen through the pipe walls.

Provide system separation in heating systems with plastic pipes that are permeable to oxygen (DIN 4726). A separate heat exchanger for this purpose is available.

Install a dirt separator in underfloor heating systems. See Viessmann Vitoset pricelist.

Underfloor heating systems and heating circuits with very large water content (>15 l/kW) should be connected to the condensing boiler via a 3-way mixer. See technical guide "Control of underfloor heating systems" or the relevant sample applications.

Install a temperature limiter in the flow of the underfloor heating circuit to restrict the maximum temperature. Observe the requirements of DIN 18560-2 [or local regulations].

Plastic pipework for radiators

We also recommend the use of a temperature limiter to restrict the maximum temperature for plastic pipework in heating circuits with radiators.

Design information (cont.)

Attic heating centre

The installation of a low water indicator, compulsory according to the DVGW [Germany], is not required when installing boilers in an attic heating centre.

The boilers are protected against water shortage in accordance with EN 12828.

Safety valve

A safety valve in accordance with TRD 721 is integrated in the Vitodens (opening pressure 3 bar (0.3 MPa)).

Route the discharge pipe in accordance with EN 12828 into a drain outlet (drain outlet kit available as an accessory). The drain outlet incorporates a siphon as a stench trap.

Low water indicator

According to EN 12828, a low water indicator can be omitted for boilers up to 300 kW, as long as heating can be reliably prevented when there is a water shortage.

Viessmann condensing boilers are equipped with a low water indicator (boil-dry protection). Tests have verified that the burner will be automatically switched off in the event of water shortage due to a leak in the heating system and simultaneous burner operation, before the boiler or the flue system reaches unacceptably high temperatures.

Water quality/frost protection

Fill and top-up water

The quality of the fill and top-up water is one of the key factors for preventing damage caused by deposits or corrosion in the heating system.

In order to prevent system damage, the European standards and national guidelines for fill and top-up water must be observed right from the design stage, e.g. VDI 2035.

- Regular checks of the appearance, water hardness, conductivity and pH value of the heating water during operation lead to higher operational reliability and system efficiency. These properties must also be observed for the top-up water. According to VDI 2035, the quantity and properties of the top-up water must always be documented in the system log or maintenance reports.
- The basis for filling the heating system is tap water of potable water quality in line with Directive 98/83/EC. For use as heating water, it is normally sufficient to soften the tap water. VDI 2035 specifies the maximum recommended concentrations of alkaline earths (hardeners), depending on the heating output and the specific system volume (ratio of the heating output of the heat generators to the heating water volume of the system): See the table below.

- We recommend always softening the fill and top-up water, as the water hardness can vary due to the mixture of different sources of supply, and the information provided by water supply utilities only gives average values. The information provided by water supply utilities is not sufficient for designing the system. In addition, it must be taken into account that the quantity of top-up water that will be added to the system during its service life cannot be predicted precisely at the design stage (especially in the case of existing heating circuits).
- If no aluminium or aluminium alloy components are installed, the heating water in systems with Viessmann heat generators does not need to be fully desalinated.
- The use of glycol as antifreeze without adequate inhibition and buffering is not permitted. The suitability of an antifreeze or other chemical additive should be certified by the manufacturer. Chemical additives in the heating water require more extensive monitoring and maintenance. Observe the manufacturer's instructions. Viessmann accepts no liability for damage or operational failure arising due to the use of unsuitable additives, incorrect dosing or poor maintenance.
- Chemical water treatments may only be planned and carried out by appropriately qualified specialist companies.

Total permissible hardness of the fill and top-up water according to VDI 2035

Total heating output of heat generator	Specific water capacity of heat generator ^{*6}	Specific system volume ^{*7}		
		≤ 20 l/kW	> 20 to ≤ 40 l/kW	> 40 l/kW
≤ 50 kW	≥ 0.3 l/kW	None	≤ 3.0 mol/m ³ (16.8 °dH)	≤ 0.05 mol/m ³ (0.3 °dH)
	< 0.3 l/kW	≤ 3.0 mol/m ³ (16.8 °dH)	≤ 1.5 mol/m ³ (8.4 °dH)	≤ 0.05 mol/m ³ (0.3 °dH)
> 50 to ≤ 200 kW	—	≤ 2.0 mol/m ³ (11.2 °dH)	≤ 1.0 mol/m ³ (5.6 °dH)	≤ 0.05 mol/m ³ (0.3 °dH)
> 200 to ≤ 600 kW	—	≤ 1.5 mol/m ³ (8.4 °dH)	≤ 0.05 mol/m ³ (0.3 °dH)	≤ 0.05 mol/m ³ (0.3 °dH)
> 600 kW	—	≤ 0.05 mol/m ³ (0.3 °dH)	≤ 0.05 mol/m ³ (0.3 °dH)	≤ 0.05 mol/m ³ (0.3 °dH)

^{*6} In the case of systems with several heat generators that have several different specific water capacities, the smallest specific water capacity is definitive.

^{*7} To calculate the specific system volume, the smallest individual heating output should be used for systems with several heat generators.

Design information (cont.)

Further requirements for the fill and top-up water independent of the heating output according to VDI 2035

Appearance

Clear, free of sedimented substances

Electrical conductivity

If the conductivity of the heating water is above **1500 µS/cm** due to a high salt content (e.g. in supply areas near the coast), desalination is necessary.

pH value

Materials in the system	pH value
Without aluminium alloys	8.2 to 10.0
With aluminium alloys	8.2 to 9.0

Information about system design

- For softening the heating water, use softening systems with water flow meters: See Vitoset pricelist.
- During installation, ensure that individual pipework sections can be drained separately. This avoids the need to drain all the heating water in the case of maintenance and repair work.
- As the formation of sludge and magnetite in the heating water cannot generally be completely prevented during operation, we recommend the installation of suitable magnetic dirt separators: See Vitoset pricelist.

Expansion vessels

In accordance with EN 12828, water heating systems must be equipped with an expansion vessel.

The boiler has an integral expansion vessel:

Vitodens 050-W: Capacity 8 l

Pre-charge pressure in the delivered condition: 0.75 bar (0.075 MPa)
Determine the size of the expansion vessel to be installed in accordance with EN 12828.

If the integral expansion vessel is insufficient, install a suitably sized expansion vessel on site.

Notes on commissioning and operating the system

- In order to prevent corrosion by remaining flushing water, fill the system completely immediately after flushing.
- Even treated fill water contains oxygen and small amounts of foreign matter. In order to prevent local concentrations of corrosion products and other deposits on the heating surfaces of the heat generator, commission the system in stages with a high heating water flow rate. Start with the heat generator at its lowest output. For the same reason, in the case of multi boiler systems and cascades, commission all heat generators at the same time.
- If extending the system or conducting maintenance or repair work, only drain the pipework sections where absolutely necessary.
- Check and clean filters, dirt traps and other blow-down or separating facilities in the heating water circuit after filling and commissioning.
- Special regional regulations regarding fill and top-up water must be observed. When disposing of heating water containing additives, check whether additional treatment may be required before it is discharged into the public waste water system.
CH: Observe SWKI guideline BT 102-01.

Note

When hydraulically connecting the diaphragm expansion vessel, ensure that there is always a connection between the diaphragm expansion vessel and the heat generator.

For example, when the thermostat valves are closed and if the 3-way diverter valve is set to "DHW". The 3-way diverter valve is installed in the heating water flow.

5.5 Intended use

The appliance is intended solely for installation and operation in sealed unvented heating systems that comply with EN 12828, with due attention paid to the associated installation, service and operating instructions. It is only designed for heating up heating water that is of potable water quality.

Intended use presupposes that a fixed installation in conjunction with permissible, system-specific components has been carried out.

The appliance is intended exclusively for domestic or semi-domestic use; even users who have not had any instruction are able to operate the appliance safely.

Commercial or industrial usage for a purpose other than heating the building or DHW shall be deemed inappropriate.

Any usage beyond this must be approved by the manufacturer in each individual case.

Incorrect usage or operation of the appliance (e.g. the appliance being opened by the system user) is prohibited and will result in an exclusion of liability. Incorrect usage also occurs if the components in the heating system are modified from their intended use (e.g. if the flue gas and ventilation air paths are sealed).

Control unit

6.1 Layout and functions

Modular design

The control unit is integrated into the Vitodens.

Control unit (cont.)

The control unit comprises electronics modules and a programming unit:

- HMI programming unit with 7-segment black/white display and integral TCU communication module
- HBMU heat management unit:
 - For connecting actuators and sensors
- HBMU with electric combustion control
- Status indicator (Lightguide) for operating and fault display

The control unit can be set to the following operating modes:

- Weather-compensated operation
 - An outside temperature sensor (accessories) must be connected.
- Constant operation:
 - 3 set flow temperatures possible, depending on level (reduced, standard and comfort)
- Operation with an OpenTherm controller is possible as an alternative to weather-compensated operation.

Note

The OpenTherm controller cannot be operated simultaneously with PlusBus.

Programming unit

- Connectivity via:
 - Integral WiFi interface (Vitodens 050-W only)
 - Access point mode
 - Low power radio
- With digital time switch
- Touch buttons for:
 - Navigation
 - Settings
 - Confirmation
 - Menu
- Adjustment of:
 - Set room temperature
 - Set flow temperature (in constant operation)
 - Set DHW temperature
 - Heating curves
 - Parameter
 - Test modeOther settings, e.g. Actuator test, can be made using the software tool
- Display of:
 - Outside temperature
 - Heat generator flow temperature
 - Flow temperature in heating circuits with mixer
 - Set flow temperature
 - DHW temperature
 - Operating data
 - Diagnostic data
 - Fault messages

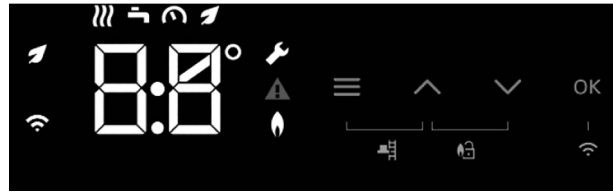

Functions

- Control of the flow temperature (selectable):
 - Weather-compensated
 - Constant, optionally with room thermostat
 - OpenTherm
- Control of 1 heating circuit without mixer
- Electronic maximum and minimum temperature limit
- Demand-dependent heating circuit pump and burner shutdown control
- Setting a variable heating limit (only possible on 16, 19, 25 and 32 kW output sizes)
- Heating system frost protection monitoring
- Integral diagnostic system
- Commissioning via commissioning assistant
- Cylinder temperature controller with priority control
- Hygiene function for DHW heating (short term heating to a higher temperature)
- External heating circuit hook-up (weather-compensated control of flow temperature for up to 2 heating circuits in conjunction with room thermostat)

To reduce the heat-up output, the reduced room temperature can be raised when outside temperatures are low. To shorten the heat-up time after a setback phase the flow temperature is raised for a limited time.

Under the German Buildings Energy Act, separate temperature control is required for each room e.g. by means of thermostatic valves.

Control unit (cont.)

Frost protection function

- The frost protection function will start when the outside temperature falls below approx. +1 °C.
With active frost protection, the heating circuit pump is switched on and set to reduced flow temperature.
- If the actual temperature in the DHW cylinder is < 5 °C, the DHW cylinder is heated to 20 °C. If weather-compensated operation is configured with external heating circuit hook-up, then the heating circuit frost protection function is not active (if the contact is not assigned). Frost protection for the heating circuit must be provided on site.
- The frost protection function will stop when the outside temperature exceeds approx. +3 °C.

Heating curve setting (slope and level)

The flow temperature of the heating circuit without mixer and the flow temperature of the heating circuits with mixer (in conjunction with the extension kit for one heating circuit with mixer) are controlled in weather-compensated mode. The flow temperature of the heat generator is therefore automatically regulated to between 0 and 40 K above the currently required set flow temperature (delivered condition 8 K).

The flow temperature required to reach a specific room temperature depends on the heating system and the thermal insulation of the building to be heated.

Adjusting the heating curves matches the boiler water temperature and the flow temperature to these conditions.

Heating curves:

The flow temperature is restricted at the upper end of the scale by the temperature limiter and the maximum temperature set at the electronic maximum temperature limiter.

The flow temperature of the heating circuits cannot exceed the flow temperature of the heat generator.

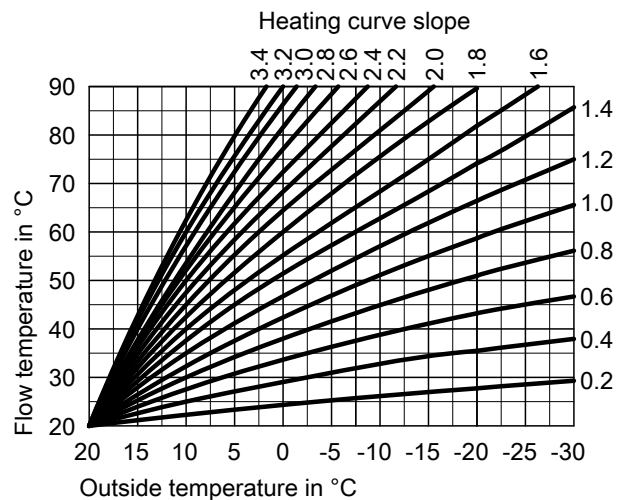

Flow temperature sensor

The flow temperature sensor is connected to the HBMU heat management unit and installed in the appliance.

Specification

Sensor type	Viessmann NTC 10 kΩ at 25 °C
Permissible ambient temperature	
– Operation	0 to +130 °C
– Storage and transport	–20 to +70 °C

Cylinder temperature sensor

Standard delivery for:

Vitodens 050-W:

- Part of the standard delivery of the connection set for DHW cylinders below the boiler (120 or 150 l) (order separately)
- Part of the standard delivery of the connection set for DHW cylinders adjacent to the boiler (160 to 400 l) or alternative DHW cylinders (order separately)
- Cylinder temperature sensor (part no. ZK04671)
Required with on-site DHW cylinder

Specification

Cable length	3.75 m, fully wired
IP rating	IP 32
Sensor type	Viessmann NTC 10 kΩ at 25 °C
Permissible ambient temperature	
– Operation	0 to +90 °C
– Storage and transport	–20 to +70 °C

6.2 Specification – control unit

Rated voltage	230 V~
Rated frequency	50 Hz
Rated current	4 A
Protection class	I
Permissible ambient temperature	
– Operation	Frost-free, dry and heated room
– Storage and transport	–20 to +65 °C
Electronic temperature limiter setting (heating mode)	91 °C (cannot be altered)
Setting range for DHW temperature	10 to 60 °C
Setting range for heating curve	
Slope	0.2 to 3.5
Level	–13 to 40 K
TCU communication module (integral)	
WiFi frequency band	2400 - 2483.5 MHz
Max. transmitting power	+ 17 dBm
Zigbee frequency band	2400 - 2483.5 MHz
Max. transmitting power	+ 10 dBm
Supply voltage	24 V $\overline{\text{DC}}$
Power consumption	4 W

6.3 Accessories for control unit

Overview of control accessories

Accessories	Vitodens 050-W	Vitodens 100-W
Vitotrol 100, type RT Part no. 7141709	X	X
Vitotrol 100, type UTA Part no. 7170149	X	X
Vitotrol 100, type UTA-RF Part no. 7454521	X	
Vitotrol 100, type UTDB Part no. Z007691	X	X
Vitotrol 100, type UTDB Part no. Z007694	X	
Vitotrol 100, type UTDB-RF Part no. Z007692	X	
Vitotrol 100, type UTDB-RF Part no. Z007695	X	
Vitotrol 100, type UTDB-RF Part no. 7296064		X
Vitotrol 100, type UTDB-RF2 Part no. Z011244	X	
Vitotrol 100, type UTDB-RF2 Part no. Z011486	X	
OpenTherm modulating room temperature controller Part no. Z014134	X	
Analogue time switch Part no. 7522678	X	
Outside temperature sensor Part no. ZK04306	X	
Outside temperature sensor Part no. Z006506		X
Contact thermostat Part no. ZK04647	X	X
Cylinder demand junction box Part no. 7296968	X	X
Connectivity pack Part no. ZK06130	X	X

Control unit (cont.)

Vitotrol 100 RT

Part no. 7141709

- Room thermostat with switching output (2-point output)
- Operation with 230 V~ rated voltage

Vitotrol 100, type UTA

Part no. 7170149

Room thermostat

- With switching output (2-point output)
- With analogue time switch
- With adjustable individual day program
- Standard switching times are factory-set (individually programmable)
- Shortest switching interval 15 minutes

The Vitotrol 100 is installed in the main living room on an internal wall opposite radiators, although never inside shelving units, in recesses, or immediately by a door or heat source (e.g. direct sunlight, fireplace, TV set, etc.).

Control unit connection:

3-core cable with a cross-section of 1.5 mm² (no green/yellow wire) for 230 V~.

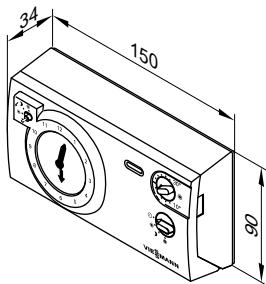

Specification

Rated voltage	230 V/50 Hz
Rated breaking capacity of the contact	6(1) A 250 V~
IP rating	IP 20 to EN 60529 Ensure through design/installation
Permissible ambient temperature	
– Operation	0 to +40 °C
– Storage and transport	–20 to +60 °C
Set value setting range for standard mode and reduced mode	10 to 30 °C
Set room temperature in standby mode	6 °C

Vitotrol 100, type UTDB

Part no. Z007691

Room temperature controller

- With switching output (2-point output)
- With digital time switch
- With individual day and seven-day program
- Operation with user prompts:
 - 3 preselected time programs, individually adjustable
 - Constant manual mode with adjustable set room temperature
 - Frost protection mode
 - Holiday program
- With selector keys for party and economy mode

Installation in the main living room on an internal wall opposite radiators. Never install inside shelving units, in recesses, or immediately by a door or heat source (e.g. direct sunlight, fireplace, TV set, etc.).

Operation independent of mains power supply (2 x 1.5 V Mignon alkaline batteries, type LR6/AA, battery life approx. 1.5 years).

Control unit connection:

2-core cable with a cross-section of 0.75 mm² for 230 V~.

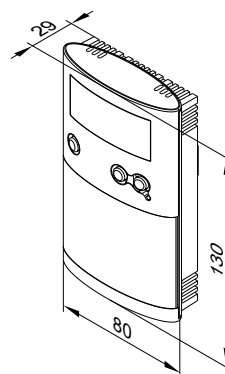

Specification

Rated voltage	3 V– Battery LR6/AA
Rated breaking capacity of the floating contact	
– max.	6(1) A, 230 V~
– min.	1 mA, 5 V–
IP rating	IP 20 to EN 60529 Ensure through design/installation
Function type	RS type 1B to EN 60730-1

Control unit (cont.)

Permissible ambient temperature	
– Operation	0 to +40 °C
– Storage and transport	–25 to +65 °C
Setting range	
– Comfort temperature	10 to 40 °C
– Setback temperature	10 to 40 °C
– Frost protection temperature	5 °C
Power reserve during battery change	
	3 min

Vitotrol 100, type UTDB

Part no. Z007694

Room temperature controller

- With switching output (two-point output)
- With digital time switch
- With individual day and seven-day program
- Operation with user prompts:
 - 3 preselected time programs, individually adjustable
 - Constant manual mode with adjustable set room temperature
 - Frost protection mode
 - Holiday program
- With selector keys for party and economy mode

Installation in the main living room on an internal wall opposite radiators. Never install inside shelving units, in recesses, or immediately by a door or heat source (e.g. direct sunlight, fireplace, TV set, etc.).

Operation independent of mains power supply

Control unit connection:

2-core lead with a cross-section of 0.75 mm² for 230 V~.

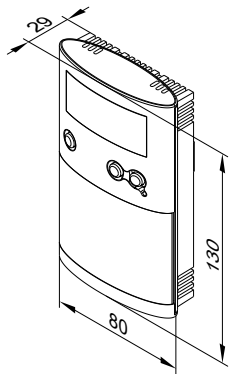

Specification

Rated voltage	3 V– 2 LR6/AA batteries
Rated breaking capacity of the floating contact	6(1) A, 230 V~ 1 mA, 5 V–
IP rating	IP 20 to EN 60529; ensure through design/installation
Function type	RS type 1B to EN 60730-1
Permissible ambient temperature	
– Operation	0 to +40 °C
– Storage and transport	–25 to +65 °C
Setting range	
– Comfort temperature	10 to 40 °C
– Setback temperature	10 to 40 °C
– Frost protection temperature	5 °C
Power reserve during battery change	3 min

Vitotrol 100, type UTDB-RF

Part no. Z007692

Room temperature controller with integral wireless transmitter and receiver

- With digital time switch
- With individual day and seven-day program
- Operation with user prompts:
 - 3 preselected time programs, individually adjustable
 - Constant manual mode with adjustable set room temperature
 - Frost protection mode
 - Holiday program
- With selector keys for party and economy mode

Installation in the main living room on an internal wall opposite radiators. Never install inside shelving units, in recesses, or immediately by a door or heat source (e.g. direct sunlight, fireplace, TV set, etc.). Room temperature controller operation independent of mains power supply (2 x 1.5 V Mignon alkaline batteries, type LR6/AA, battery life approx. 1.5 years).

Receiver with relay state indication.

Connection of the receiver to the control unit (subject to control unit type):

- 4-core cable with a cross-section of 1.5 mm² for 230 V~
or
- 3-core cable without green/yellow wire for 230 V~
or
- 2-core lead with a cross-section of 0.75 mm² for LV for the connection to the control unit, plus an additional 2-core cable for the 230 V~ power supply

Control unit (cont.)

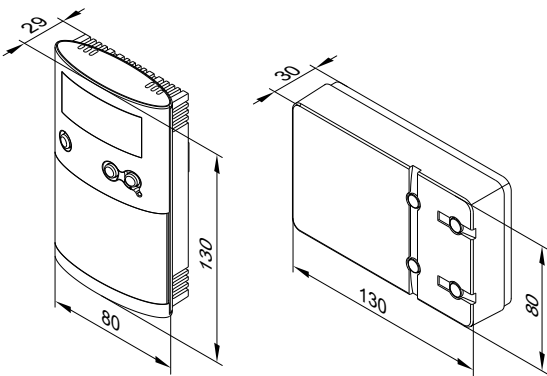

Specification, room temperature controller

Rated voltage	3 V-
Transmission frequency	868 MHz
Transmission	< 10 mW
Range	approx. 25 to 30 m inside buildings, subject to construction
IP rating	IP 20 to EN 60529 Ensure through design/installation

Function type	RS type 1B to EN 60730-1
Permissible ambient temperature	
– Operation	0 to +40 °C
– Storage and transport	–25 to +65 °C
Setting range	
– Comfort temperature	10 to 40 °C
– Setback temperature	10 to 40 °C
– Frost protection temperature	5 °C
Power reserve during battery change	3 min

Specification, receiver

Operating voltage	230 V~ ± 10 % 50 Hz
Rated breaking capacity of the floating contact	
– max.	6(1) A, 230 V~
– min.	1 mA, 5 V-
IP rating	IP 20 to EN 60529 Ensure through design/installation
Safety category	II to EN 60730-1 subject to correct installation
Permissible ambient temperature	
– Operation	0 to +40 °C
– Storage and transport	–25 to +65 °C

Vitotrol 100, type UTDB-RF

Part no. 7296064

- Room thermostat with integral wireless transmitter and separate receiver with 1 switching output for central heating and DHW heating (same switching times)
- With analogue time switch

- With individual day program
- With room thermostat, 3 V battery operation, receiver to be installed in the control unit

Vitotrol 100, type UTDB-RF

Part no. Z007695

- Room temperature controller with integral wireless transmitter and separate receiver with switching output (2-point output)
- With menu-guided operation
- With digital time switch

- With individual day and seven-day program
- With 3 preset time programs, individually adjustable
- Room temperature controller with 3 V battery operation, receiver with 230 V mains voltage

Vitotrol 100, type UTDB-RF2

Part no. Z011486

Room temperature controller with integral wireless transmitter and wireless receiver for installation in the control unit support

- With digital time switch
- With individual day and seven-day program
- Operation with user prompts:
 - 3 preselected time programs, individually adjustable
 - Constant manual mode with adjustable set room temperature
 - Frost protection mode
 - Holiday program
- With selector keys for party and economy mode

Installation in the main living room on an internal wall opposite radiators. Never install inside shelving units, in recesses, or immediately by a door or heat source (e.g. direct sunlight, fireplace, TV set, etc.). Operation independent of mains power supply
Wireless receiver with relay state indication.

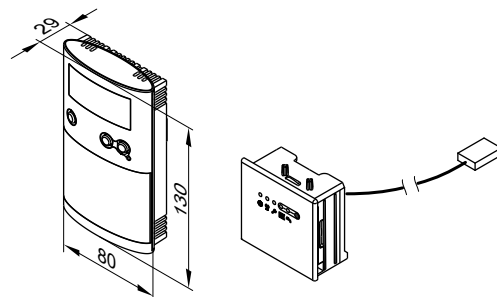

Specification, room temperature controller

Rated voltage	3 V- 2 LR6/AA batteries
Transmission frequency	868 MHz
Transmission	< 10 mW
Range	Approx. 25 to 30 m inside buildings, subject to construction
IP rating	IP 20 to EN 60529; ensure through design/installation
Function type	RS type 1B to EN 60730-1

Control unit (cont.)

Permissible ambient temperature	
– Operation	0 to +40 °C
– Storage and transport	–25 to +65 °C
Setting range	
– Comfort temperature	10 to 40 °C
– Setback temperature	10 to 40 °C
– Frost protection temperature	5 °C
Power reserve during battery change	3 min

Wireless receiver

- For installation in the control unit support
- With power cable and connector for connection to the control unit

OpenTherm modulating room temperature controller

Part no. Z014134

- With seven-day program
- With connecting lead
- Operation without batteries (power supplied by the boiler)

Contact temperature limiter

Part no. ZK04647

Can be used as a maximum temperature limiter for underfloor heating systems (only in conjunction with metal pipes).

The temperature limiter is fitted to the heating flow. If the flow temperature is too high, the temperature limiter switches off the heat generator.

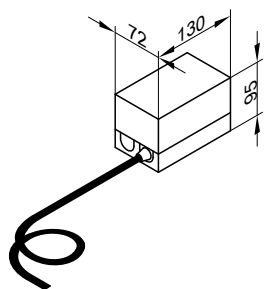

Specification

Lead length	1.5 m
Setting range	30 to 80 °C
Switching differential	6.5 K ±2.5 K
Breaking capacity	6(1.5) A, 250 V~
Setting scale	Inside the enclosure
Protection rating to EN 60529	IP 41

Outside temperature sensor

Part no. ZK04306

Installation location:

- North or north-west facing wall of the building
- 2 to 2.5 m above the ground; for multi storey buildings in the upper half of the second floor

Connection:

- 2-core lead, length up to 35 m with a cross-section of 1.5 mm² (copper)
- Never route this cable immediately next to 230/400 V cables.

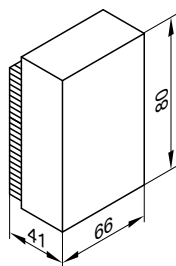

Specification

IP rating	IP 43 to EN 60529; ensure through design/installation.
Sensor type	Viessmann NTC 10 kΩ at 25 °C
Permissible ambient temperature during operation, storage and transport	–40 to +70 °C

Control unit (cont.)

Outside temperature sensor

Part no. Z006 506

Installation site:

- North or north-west facing wall of the building
- 2 to 2.5 m above the ground, for multi storey buildings in the upper half of the second floor

Connection:

- 2-core lead, length max. 35 m with a cross-section of 1.5 mm² copper.
- Never route this lead immediately next to 230/400 V cables

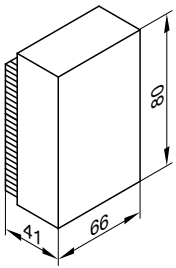

Specification

IP rating	IP 43 to EN 60529; ensure through design/installation
Sensor type	Viessmann NTC 10 k Ω , at 25 °C
Permissible ambient temperature during operation, storage and transport	-40 to +70 °C

Cylinder demand junction box

Part no. 7296968

- 230 V~
- For operation with a cylinder temperature sensor

Connectivity pack

Part no. ZK06130

For retrofitting WiFi in appliances without integral WiFi module. For operation and local access for service and commissioning via Viessmann apps (without active internet connection).

- WiFi module
- Connecting cable

Appendix

7.1 Regulations / Directives

Regulations and directives

We, Viessmann Climate Solutions SE, declare that the Vitodens gas condensing boilers have been tested and approved in accordance with the currently applicable directives/regulations, standards and technical rules.

Observe all engineering standards of the building authorities and statutory requirements applicable to the installation and operation of this system.

Installation, gas and flue gas connections, commissioning, electrical connections and general service/maintenance may only be carried out by a registered contractor.

The installation of a condensing boiler must be reported to and approved by the relevant gas supply utility.

In some regions, permits may be required for the flue system and condensate connection to the public waste water system.

The local flue gas inspector and water authorities must be informed prior to commencing installation.

We recommend that maintenance and cleaning procedures are performed annually. As part of the maintenance procedure, check the correct function of the entire system. Any faults that occur must be rectified.

Condensing boilers must only be operated with specially designed, tested and approved flues.

Only an authorised contractor may convert this boiler for use in countries other than those stated on the type plate. That contractor must also arrange approval in accordance with the statutes of the relevant country.

Keyword index

A		O	
Accessories		Open flue operation.....	33
– For installation.....	27	Outlet temperature sensor.....	51
Accessories for control unit.....	52	Outside temperature sensor.....	56, 57
Anti-corrosion agents.....	47	Overview of control accessories.....	52
C		P	
Cables.....	35	pH value.....	48, 49
Carbon monoxide.....	33, 34	Pre-installation.....	36
CO limiter.....	33, 34	Product description	
Comfort function.....	12	– Vitodens 050-W.....	4
Condensate.....	47	– Vitodens 100-W.....	14
Condensate connection.....	46	Programming unit.....	50
Conductivity.....	48	Protection.....	35
Contact temperature limiter.....	56	R	
Control unit.....	49	Replacing third party boilers.....	41
Cylinder temperature sensor.....	51	Room sealed operation.....	34
D		Room temperature controller.....	53, 54
DHW circulation.....	45	Room thermostat.....	53, 54, 55
DHW connection.....	44	S	
DHW cylinder below the boiler.....	21	Safety equipment.....	48
Dirt separator.....	49	Safety valve.....	45, 48
Dirt trap.....	49	Safety zone, electrical.....	35
Drain outlet set.....	30	Separating facility.....	49
Draw-off rate.....	12	Shock arrestors.....	45
Dual mode DHW cylinder.....	24	Siting conditions.....	33
E		Slope.....	51
Electrical conductivity.....	49	Softening.....	49
Electrical connection.....	35	Specification	
Electrical safety zone.....	35	– Control unit.....	52
Expansion vessel.....	49	– Vitodens 050-W.....	6
F		– Vitodens 100-W.....	15
Fill water.....	48	Specific system volume.....	48
Flow temperature sensor.....	51	Standby instantaneous water heater.....	12
Flushing water.....	49	SWKI guideline.....	49
Frost protection.....	48	System design.....	47
Frost protection function.....	51	T	
G		Temperature controller	
Gas connection.....	35	– Contact temperature.....	56
German Buildings Energy Act.....	50	Temperature sensors	
H		– Flow temperature sensor.....	51
Hardness.....	48	– Outside temperature sensor.....	56, 57
Heating curves.....	51	Thermally activated safety shut-off valve.....	35
Hydraulic connection.....	47	Top-up water.....	48
I		V	
Installation.....	36	VDI 2035.....	48, 49
Installation in unfinished buildings.....	36	Vitocell 100.....	21
Installation room.....	33	Vitocell 100-W.....	24
Instantaneous water heater.....	44	Vitocell 100-W adjacent to the boiler	
Interlock circuit.....	33	– Pressure drop on DHW side.....	25
L		Vitotrol 100	
Level.....	51	– UTA.....	53
Low water indicator.....	48	– UTDB.....	53, 54
M		– UTDB-RF.....	54, 55
Magnetite.....	49	– UTDB-RF2.....	55
Mounting frame.....	28	W	
N		Waste water system.....	49
Neutralisation.....	46	Water hardness.....	48
Neutralising system.....	47	Weather-compensated control	
		– Frost protection function.....	51
		Weather-compensated control unit	
		– Functions.....	50
		– Programming unit.....	50
		Wet room.....	35



Subject to technical modifications.

Viessmann Climate Solutions SE
35108 Allendorf / Germany
Telephone: +49 6452 70-0
Fax: +49 6452 70-2780
www.viessmann.com

Viessmann Limited
Hortonwood 30, Telford
Shropshire, TF1 7YP, GB
Telephone: +44 1952 675000
Fax: +44 1952 675040
E-mail: info-uk@viessmann.com

6176070