

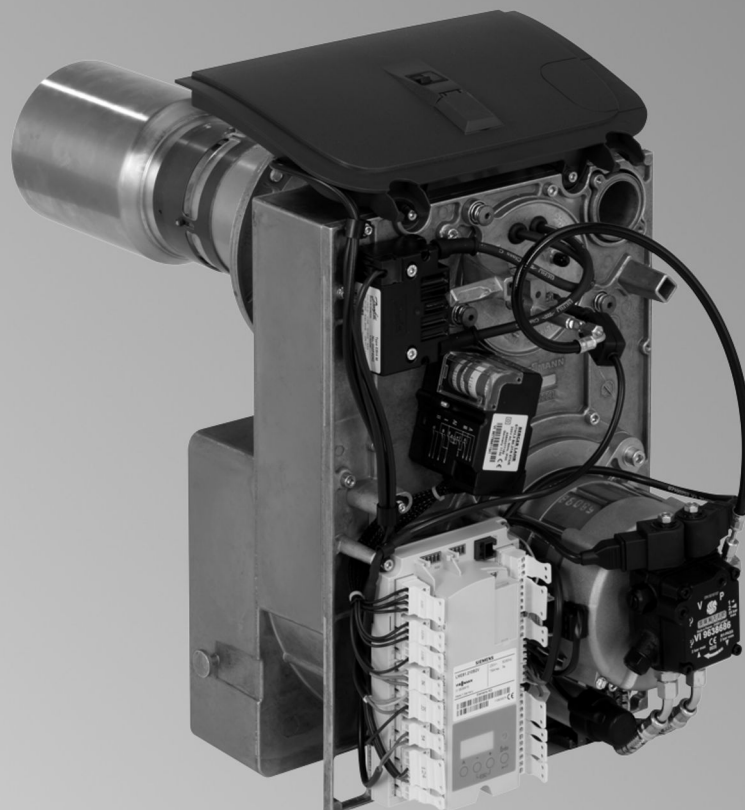

Vitoflame 300
Type VHG III
Pressure-jet oil burner
for the Vitorondens 200-T, 67.6 to 107.3 kW



VITOFLAME 300



Safety instructions

-  Please follow these safety instructions closely to prevent accidents and material losses.

Safety instructions explained

-  **Danger**
This symbol warns against the risk of injury.

Note
Details identified by the word "Note" contain additional information.

-  **Please note**
This symbol warns against the risk of material losses and environmental pollution.

Target group

These instructions are exclusively intended for qualified contractors.

- Work on electrical equipment may only be carried out by a qualified electrician.
- The system must be commissioned by the system installer or a qualified person authorised by the installer.

Regulations to be observed

- National installation regulations
- Statutory regulations for the prevention of accidents
- Statutory regulations for environmental protection
- Codes of practice of the relevant trade associations
- Relevant country-specific safety regulations

Safety instructions for working on the system

Working on the system

- Isolate the system from the power supply (e.g. by removing the separate fuse or by means of a mains isolator) and check that it is no longer live.
- Safeguard the system against reconnection.

-  **Danger**
Hot surfaces can cause burns.
- Before maintenance and service work, switch OFF the appliance and let it cool down.
 - Never touch hot surfaces on the boiler, burner, flue system or pipework.

Safety instructions (cont.)

- !** **Please note**
 Electronic assemblies can be damaged by electrostatic discharge. Prior to commencing any work, touch earthed objects such as heating or water pipes to discharge static loads.

Repair work

- !** **Please note**
 Repairing components that fulfil a safety function can compromise the safe operation of the system. Replace faulty components only with genuine Viessmann spare parts.



Auxiliary components, spare and wearing parts

- !** **Please note**
 Spare and wearing parts that have not been tested together with the system can compromise its function. Installing non-authorised components and making non-approved modifications or conversions can compromise safety and may invalidate our warranty. For replacements, use only original spare parts supplied or approved by Viessmann.

Safety instructions for operating the system**If you smell flue gas**

-  **Danger**
 Flue gas can lead to life threatening poisoning.
- Shut down the heating system.
 - Ventilate the installation site.
 - Close the doors to living spaces to prevent flue gases from spreading.

What to do if water escapes from the appliance

-  **Danger**
 If water escapes from the appliance there is a risk of electric shock. Switch OFF the heating system at the external isolator (e.g. fuse box, domestic distribution board).
-  **Danger**
 If water escapes from the appliance there is a risk of scalding. Never touch hot heating water.

Flue systems and combustion air

Ensure that flue systems are clear and cannot be sealed, for instance due to accumulation of condensate or other external causes. Ensure an adequate supply of combustion air. Instruct system users that subsequent modifications to the building characteristics are not permissible (e.g. cable/pipe-work routing, cladding or partitions).

-  **Danger**
 Leaking or blocked flue systems, or an inadequate supply of combustion air can cause life threatening poisoning from carbon monoxide in the flue gas. Ensure the flue system is in good working order. Vents for supplying combustion air must be non-sealable.

Safety instructions (cont.)

Extractors

Operating appliances that extract air to the outside (extractor hoods, extractors, air conditioning units, etc.) can create negative pressure. If the boiler is operated at the same time, this can lead to a reverse flow of flue gas.











Danger







The simultaneous operation of the boiler and appliances that extract air to the outside can result in life threatening poisoning due to a reverse flow of flue gas. Fit an interlock circuit or take suitable steps to ensure an adequate supply of combustion air.

Index		
1. Information	Symbols	6
	Spare parts lists	6
2. Commissioning, inspection, maintenance	Steps - commissioning, inspection and maintenance	7
3. Burner control unit	16
4. Troubleshooting	Diagnosis	19
	■ Faults with flash code indication	19
	■ Faults without flash code indication	20
5. Component overview	22
6. Connection and wiring diagram	24
7. Report	25
8. Specification	26
9. Standard values for burner adjustment	27
10. Appendix	Information on fuel oil	28
11. Keyword index	29

Symbols

Symbol	Meaning
	Reference to other document containing further information
	Step in a diagram: The numbers correspond to the order in which the steps are carried out.
	Warning of material losses and environmental pollution
	Live electrical area
	Pay particular attention.
	<ul style="list-style-type: none"> Component must audibly click into place. or Acoustic signal
	<ul style="list-style-type: none"> Fit new component. or In conjunction with a tool: Clean the surface.
	Dispose of component correctly.
	Dispose of component at a suitable collection point. Do not dispose of component in domestic waste.

The steps in connection with commissioning, inspection and maintenance are found in the "Commissioning, inspection and maintenance" section and identified as follows:

Symbol	Meaning
	Steps required during commissioning
	Not required during commissioning
	Steps required during inspection
	Not required during inspection
	Steps required during maintenance
	Not required during maintenance

Spare parts lists

Information about spare parts can be found on the Viessmann spare parts app.





Steps - commissioning, inspection and maintenance

			Page
		Commissioning steps	
		Inspection steps	
		Maintenance steps	
•		1. Commissioning the system.....	8
•	•	2. Checking the burner	
•	•	3. Checking the oil pressure and vacuum, adjusting the CO₂ value.....	8
•	• •	4. Checking the settings of the air damper servomotor.....	10
	• •	5. Cleaning and testing the flame monitor.....	11
	• •	6. Installing and adjusting the flame monitor (if available).....	11
	• •	7. Shutting down the system	
	• •	8. Checking the firm seating of electrical connections	
	• •	9. Cleaning the burner.....	12
	• •	10. Checking the impeller fixings	
	• •	11. Checking the flame tube fixings	
	• •	12. Replacing the nozzle.....	13
	• •	13. Checking and adjusting the ignition electrodes.....	13
	• •	14. Fitting the burner cover on the burner casing	
	• •	15. Cleaning the oil pump filter and replacing it if necessary.....	14
	• •	16. Replacing the filter element of the fuel oil filter	
•	• •	17. Commissioning the system	
•	• •	18. Checking the oil lines and connections for leaks	
	•	19. Re-testing the burner and entering the actual values into the report	





Commissioning the system

To obtain optimum combustion values, the burner must be adjusted with the boiler heated up (min. 60 °C). Also carry out tests at base load.



Boiler control unit service instructions

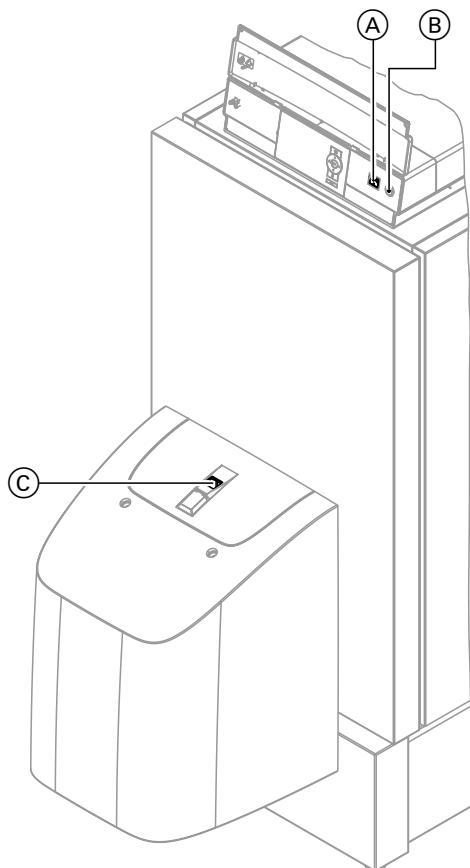

Fig. 1

Note

For fuel details, see chapter "Information on fuel oil".

1. Check the heating system pressure and the oil level in the tank.
2. Open the shut-off valves in the oil lines on the oil tank and on the filter.
3. Fill the oil suction line and the filter with fuel oil using a manual oil suction pump **before** switching the burner on.
4. Switch ON the mains isolator (outside the installation room).
5. Turn on system ON/OFF switch (B) at the control unit.
If fault indicator (A) on the control unit illuminates, press reset button (C) on the burner.



Checking the burner



Checking the oil pressure and vacuum, adjusting the CO₂ value

The oil pressure is factory-set according to the oil throughput.

When commissioning or using a sound insulation set (accessories), select the CO₂ value by adjusting the oil pressure.

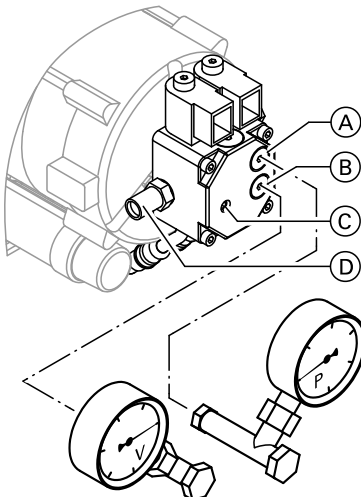

Fig. 2 Oil pump make: Danfoss

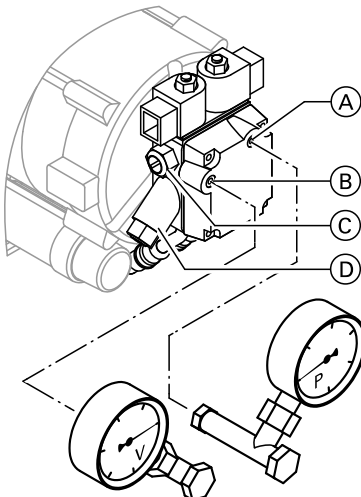

Fig. 3 Oil pump make: Suntec

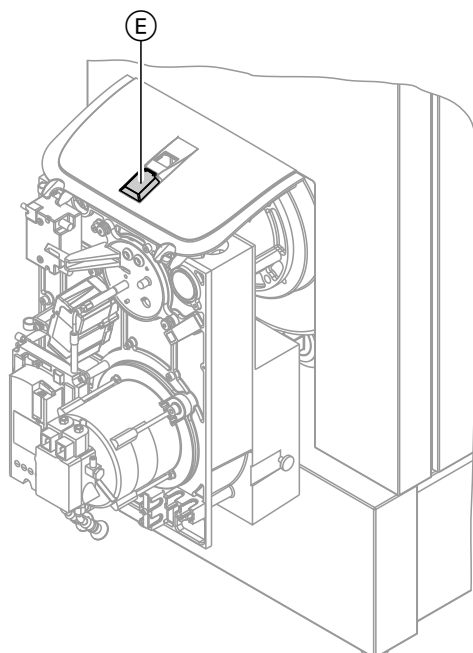

Fig. 4

1. Switch system OFF at mains isolator and safeguard against unauthorised reconnection.
2. Unscrew plug "P" (A) from the oil pump.
3. Unscrew plug "V" (B) from the oil pump.

Note

Oil may leak from the oil pump when doing this.

4. Insert a pressure gauge (measuring range 0-40 bar) and a vacuum gauge (measuring range 0-1 bar).

Note

Only seal in the pressure and vacuum gauges with copper or aluminium gaskets or with O-rings. Never use sealing tape.

5. Start the burner.

Note

The solenoid valve opens.

6. Read off the oil pressure and the vacuum of the pump on the relevant gauge (vacuum should be max. 0.35 bar at a height differential of 3 m between the oil pump and the bottom of the tank).

Note

If the vacuum pressure is higher than 0.35 bar, check the filter for contamination and check the pipe run.

7. If the CO₂ content is not between 13 to 14 % by vol., adjust it by regulating the oil pressure.

Note

Subject to pump type, the pressure adjusting screws may be located at the front or on the side of the oil pump.

- For burner stage 2, set the oil pressure at pressure adjusting screw (D). Service switch (E) is factory-set to setting 2.
- For burner stage 1, set service switch (E) to setting 1; open the flap to do so. Adjust the oil pressure by means of pressure adjusting screw (C).

Clockwise turn → pressure increases.

Anti-clockwise turn → pressure decreases.

Note

For standard values for burner adjustment, see page 27.



Checking the oil pressure and vacuum , adjusting... (cont.)

8. Test to check the actual emission values after adjusting the oil pressure.
9. Switch system OFF at mains isolator and safeguard against unauthorised reconnection.
10. Undo the pressure and vacuum gauges.
11. Check the plug seal rings for damage and replace if necessary.
Insert plugs "P" (A) and "V" (B).
12. Start the burner and check the plugs for leaks.



Checking the settings of the air damper servomotor

The air damper servomotor is factory-set and must only be adjusted in exceptional cases. Exceptions are the **replacement** of the air damper servomotor, **soot build-up** and the **altitude** above sea level of the installation site. The CO₂ value must only be adjusted by regulating the oil pressure.

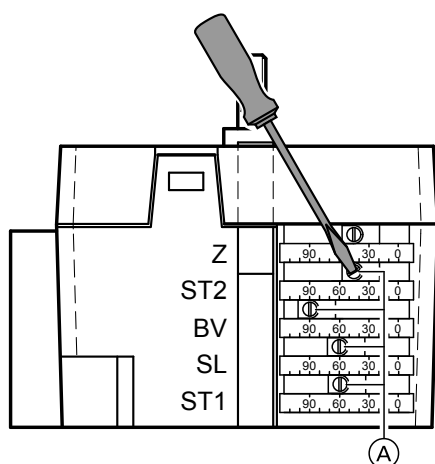

Fig. 5

The burner is equipped with an air damper servomotor with adjustable switch cams for the positioning of the air damper and the solenoid valve control. During a controlled shutdown, the burner air damper moves into the "closed" position. This reduces the cool-down losses.

The switch cams are located under the cover of the air damper servomotor. A scale ring is located adjacent to each switch cam, where the selected angle of the air damper can be checked.

The switch cams have the following functions:

Z Air damper closed (0°)

Never alter the setting of Z.

SL Ignition air setting

ST1 Air damper setting stage 1

ST2 Air damper setting stage 2

BV Solenoid valve stage 2

The switch cams for ignition air stage 1 and 2 are set at the factory. For factory settings, see chapter "Standard values for burner settings".

The switch cams are adjusted via slotted screws (A) in the cams. When doing this observe the following:

- The ignition air setting cannot be turned beyond the setting of stage 1 (turning further is blocked by cams).
- After adjusting the ignition air setting to match stage 1, always adjust the ignition air setting approx. 1-5° below stage 1.



Cleaning and testing the flame monitor

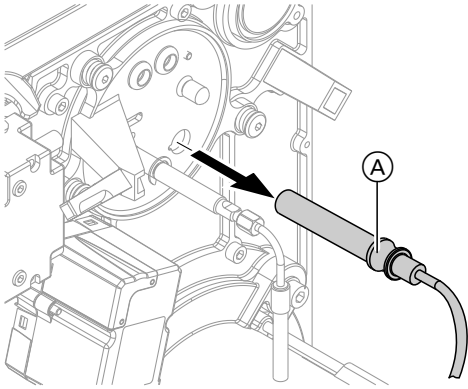

Fig. 6

Ⓐ Flame monitor

Safety check	Response
Burner start with darkened flame monitor	Fault shutdown at the end of the safety time Red flashing code, flashes 2x
Burner start with externally lit flame monitor	Fault shutdown after max. 40 s Flashes alternately green-red
Burner operation with simulated flame tear-off: Cover the flame monitor during operation and leave in this condition	Restart followed by a fault shutdown at the end of the safety time Red flashing code, flashes 2x



Installing and adjusting the flame monitor (if available)

Before fitting, check whether slider sleeve Ⓑ is pushed as far forward as it will go (x = max.).

Push-on restrictor Ⓐ must sit on flame monitor Ⓒ.

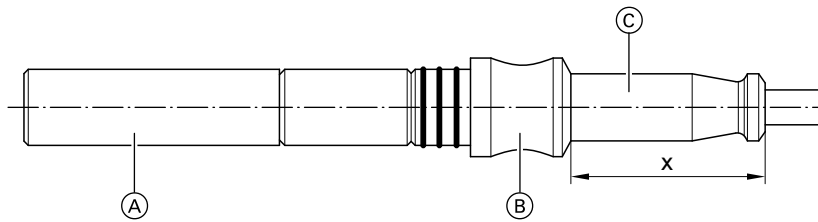

Fig. 7



Shutting down the system



Checking the firm seating of electrical connections



Cleaning the burner

 For cleaning the combustion chamber and flues, see boiler service instructions.

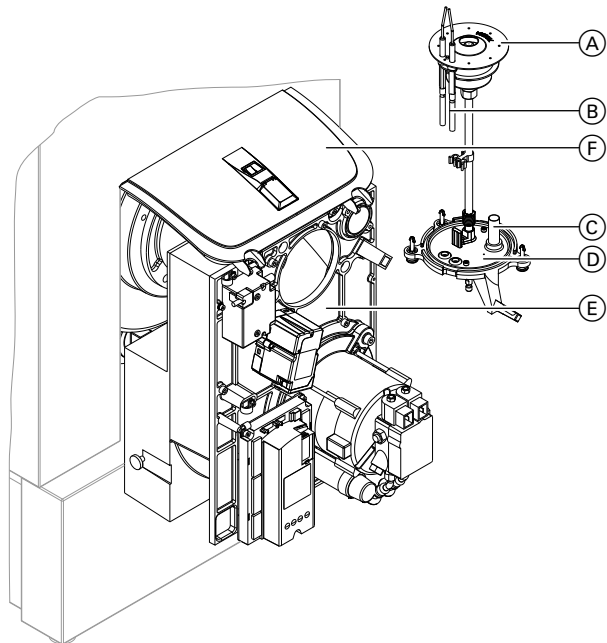

Fig. 8

1. Set the burner into its maintenance position. To do this, remove nozzle cover (D) with mixing device and slot it onto the burner casing with the blast tube connection pointing upwards or to the side.
2. Clean flame tube, sensor plate (A), ignition electrodes (B) and flame monitor (C).
3. If the burner pressure differs significantly: Remove burner cover (E) and clean casing with impeller; to do so, first remove hood adaptor (F).



Checking the impeller fixings



Checking the flame tube fixings



Replacing the nozzle

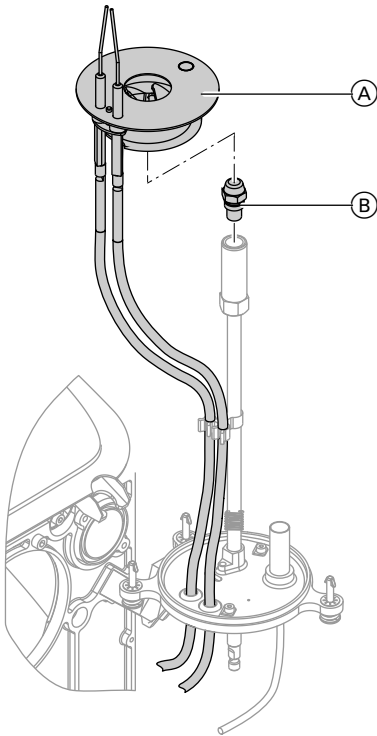

Fig. 9

1. Remove the nozzle cover with mixer device and slot it onto the burner casing with the blast tube connection pointing upwards (service position). This prevents the formation of bubbles in the blast tube connection.
2. Remove mixing assembly (A) from the blast tube connection.
3. Replace nozzle (B) (counterhold to prevent the blast tube connection from turning); during this step prevent air bubbles from forming in the blast tube connection.

Note

For the make and type of nozzle, see standard values for burner adjustment on page 27.

4. Mount mixing facility (A):
 - Position the nozzle in the centre of the sensor plate and note the distance between the sensor plate and the nozzle (see page 13).
 - Accurately position the ignition electrodes in the top centre (12 o'clock position).



Checking and adjusting the ignition electrodes

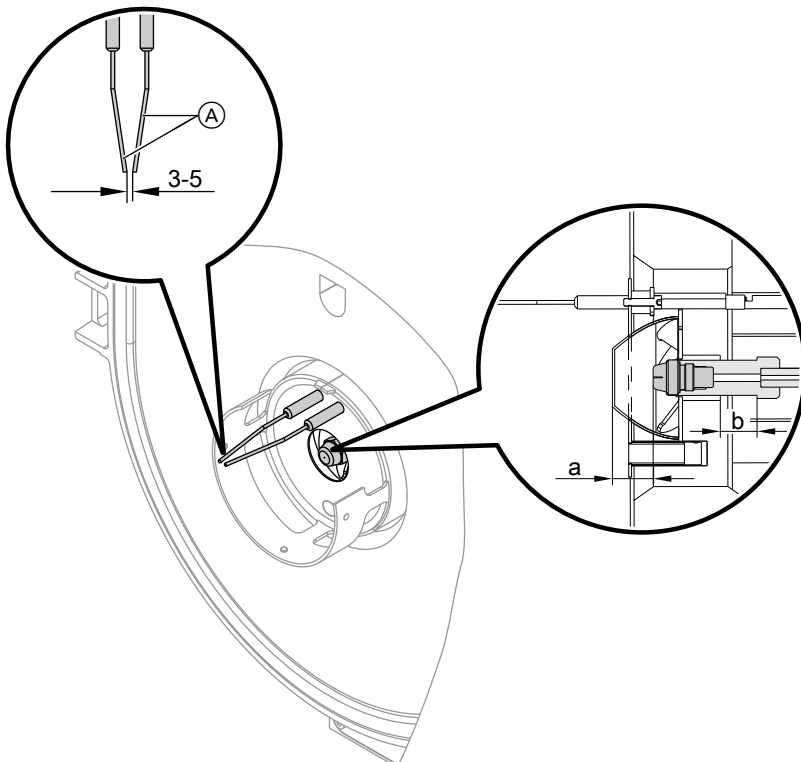

Fig. 10

1. Check ignition electrodes (A) for wear, contamination and size accuracy (see diagram), replace if necessary.
2. Clearance between mixing system and nozzle: Check either dim. a or dim. b and adjust if necessary.





Checking and adjusting the ignition electrodes (cont.)

Rated heating output	Dim. a	Dim. b
63/67.6 kW	5 mm	9.4 mm
80/85.8 kW		10.0 mm
100/107.3 kW		12.0 mm



Fitting the burner cover on the burner casing



Cleaning the oil pump filter and replacing it if necessary

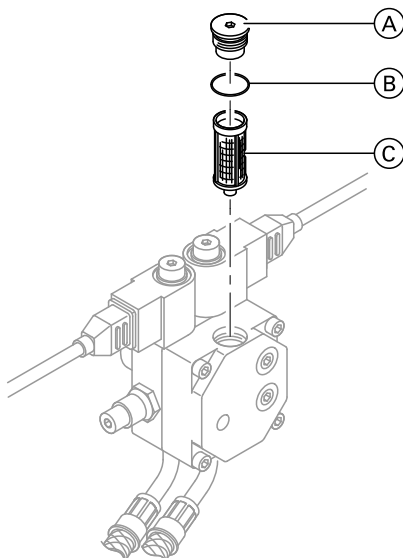

Fig. 11 Oil pump make: Danfoss

- (A) Filter plug
- (B) O-ring (replace)
- (C) Filter (replace)



Cleaning the oil pump filter and replacing it... (cont.)

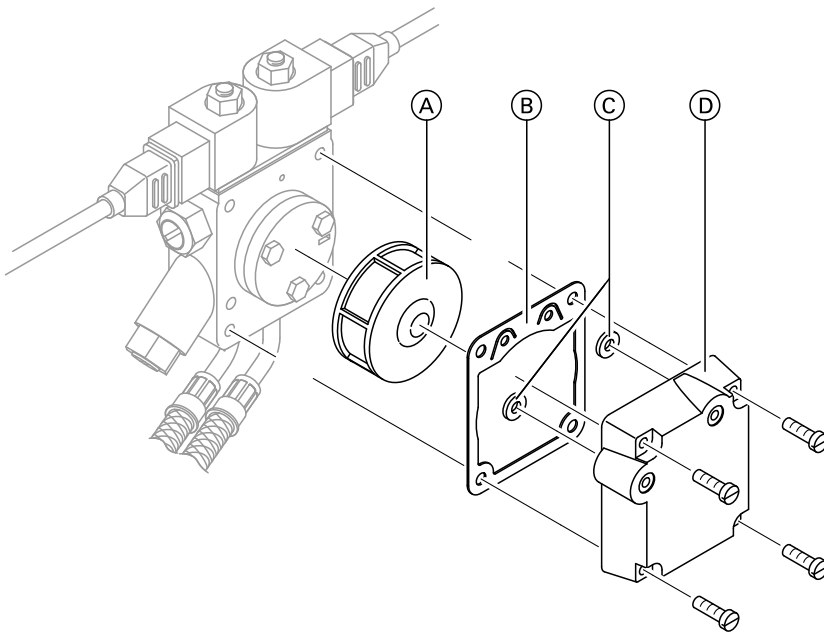

Fig. 12 Oil pump make: Suntec

- (A) Filter (clean or replace)
- (B) Flat gasket (replace)
- (C) O-rings (replace)
- (D) Cover



Replacing the filter element of the fuel oil filter



Commissioning the system



Checking the oil lines and connections for leaks



Re-testing the burner and entering the actual values into the report



Burner control unit

Program sequence during commissioning

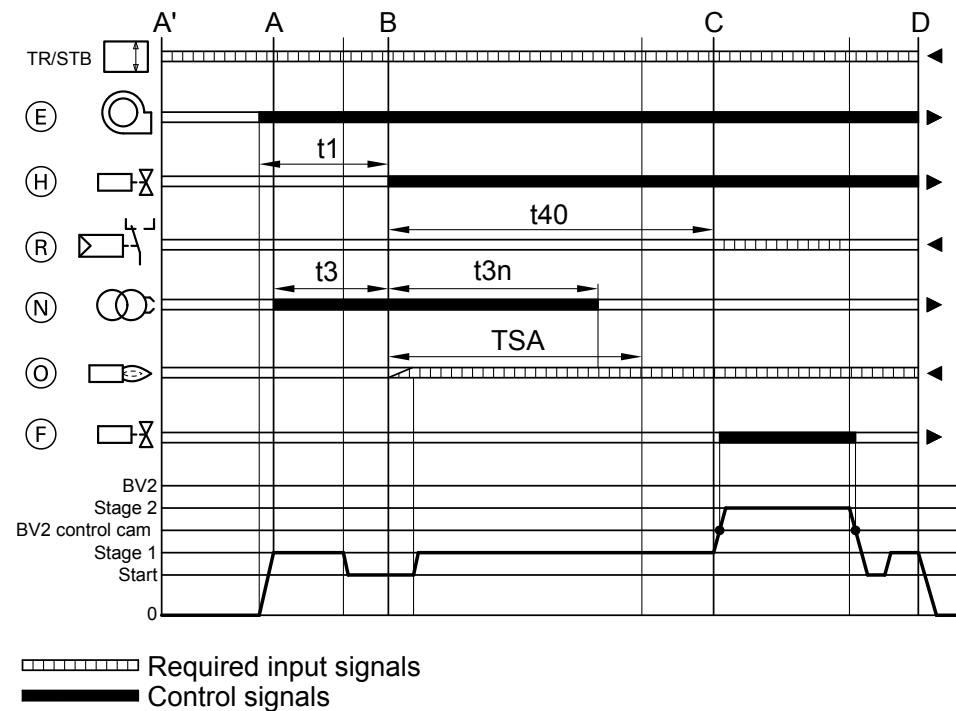

Fig. 13

Note

The output signal at the solenoid valve stage 2 (F) is dependent upon the switch position of the BV2 control cam of the solenoid valve stage 2 in the servomotor.

- A Start-up begins
- B Point of flame formation
- C Burner operating position

- D Controlled shutdown
- (E) Burner motor
- (F) Solenoid valve stage 2
- (H) Solenoid valve stage 1
- (N) Ignition transformer
- (O) Flame monitor
- (R) Output controller

t1	Pre-purge time	min. 20 s
t40	Delay time between enabling solenoid valve stage 1 and enabling controller input	approx. 11 s
t3	Pre-ignition time	approx. 20 s
t3n	Post-ignition time begins with flame (max. until end of "TSA")	max. 5 s
TSA	Start-up safety time	max. 5 s

Function and fault indications of the signal indicator (LED)

During standard operation, the operating conditions are indicated by LED signal indicator (A) through colour codes (see the following table).

After a fault shutdown, the indicator permanently illuminates red. In this condition, the optical fault cause indicator can be activated (see the following chapter "Burner fault sequence diagram").

Burner control unit (cont.)

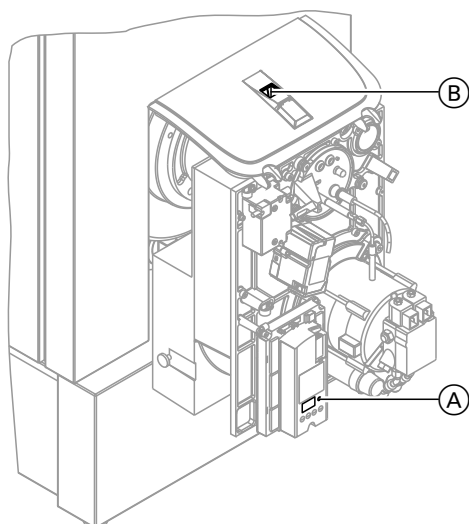
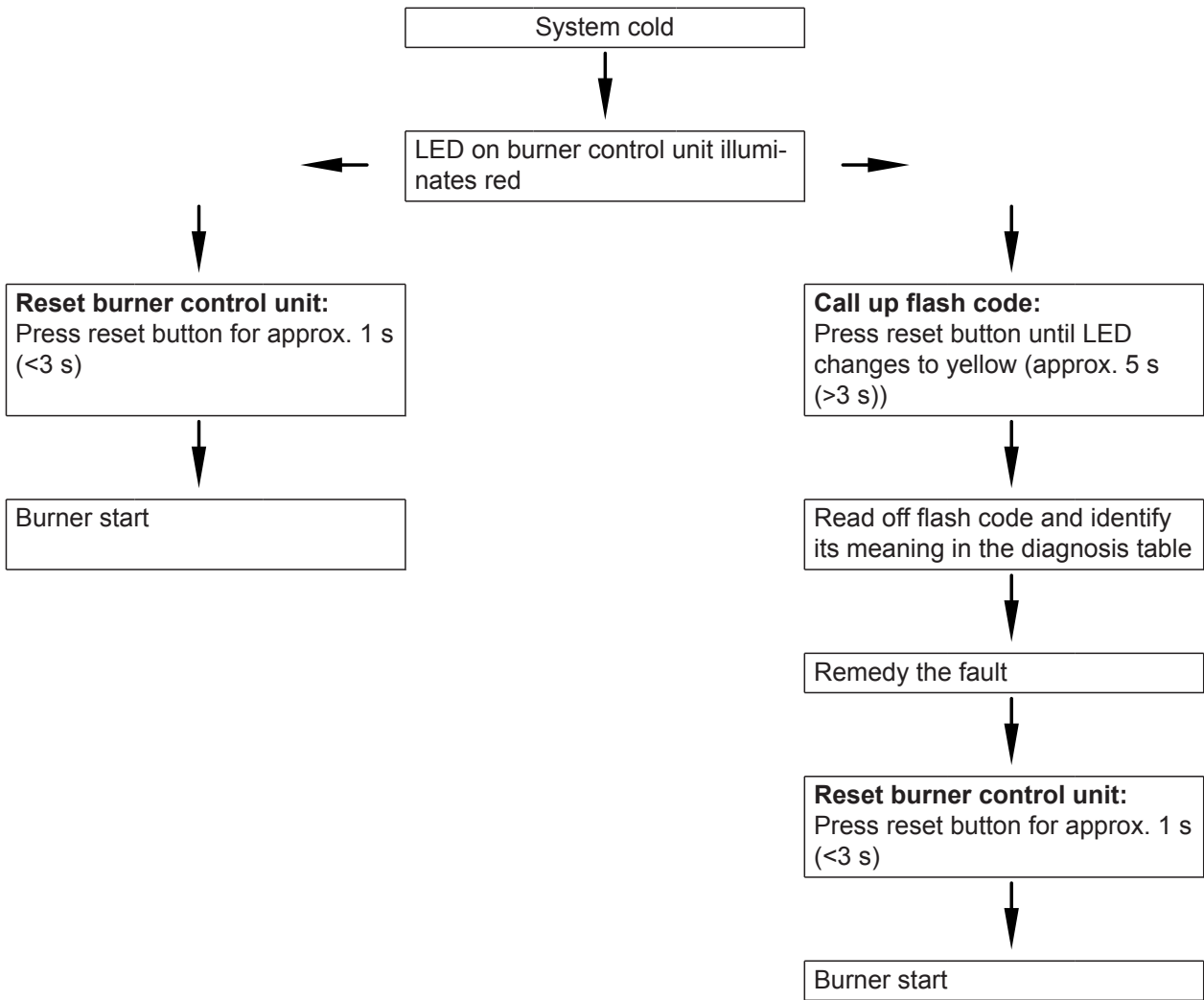

Fig. 14

1. Hold down reset button (B) for approx. 5 s (>3 s).
2. A flash code is then shown.
The number of flashes in a sequence indicates the type of fault. For an explanation, see the table in chapter "Faults with flash code indication".
3. To reset the burner and exit the fault indication, press the reset button for approx. 1 s (<3 s).

LED colour	Operating condition
Yellow, flashing	Ignition phase pre-purge, ignition activated
Green, continuous	Operation, flame stable
Green, flashing	Operation, poor flame stability
Yellow-red, flashing alternately	Undervoltage (<195 V)
Red, continuous	Fault, burner locked out
Red, flashing	Fault code indication (for an explanation, see chapter "Faults with flash code indication")
Green-red alternately	External light before burner start
Red, flickering	Interface diagnosis was activated accidentally. Pressing the reset button once (approx. 3 s) starts the burner in standard mode.

Burner fault flowchart



Parameter

Diagnosis

Faults with flash code indication

Fault	Red flash code	Cause of fault	Measure
Burner does not start (with fault indication), indicator illuminates	10 x	Wiring fault or internal burner fault; not all consumers were recognised; other error	Check the electrical connection
Burner does not start (with fault indication)	2 x	Motor faulty	Replace motor
	2 x	Coupling between motor and oil pump faulty	Replace coupling
	2 x	Oil pump seized up or sluggish	Clean the oil pump, or replace if necessary
	6 x	Servomotor faulty	Replace the servomotor
Burner starts, but no flame is formed	2 x	Ignition electrodes incorrectly adjusted	Set correctly (see chapter "Checking and adjusting the ignition electrodes")
	2 x	Ignition electrodes damp and contaminated	Clean ignition electrode block
	2 x	Insulation body of ignition electrodes cracked	Replace ignition electrode block
	2 x	Ignition transformer faulty	Replace ignition transformer
	2 x	Ignition cable faulty	Replace ignition cable
	2 x	Pump does not supply oil	Mount pressure and vacuum gauges at the pump and check build-up of pressure (see following paragraph)
Pump does not supply oil	2 x	Shut-off valves closed at filter or in oil line	Open valves
	2 x	Filter blocked	Clean filters (fuel oil filter and pump filter), replace if necessary
	2 x	Coupling between motor and pump faulty	Replace coupling
	2 x	Leak in suction line or filter bowl	Retighten fittings. Check the oil lines for leaks; seal if necessary.
	2 x	Oil flow and return hoses interchanged	Connect correctly acc. to markings on pump
	2 x	Vacuum in suction line too high (above 0.35 bar)	Check sizing of oil line cross-section. Replace filter. Check the external oil valve.
	2 x	External oil valve faulty	Check external oil valve and replace if necessary
Burner starts, but no oil is injected	2 x	Solenoid valve coil faulty	Replace solenoid valve coil
	2 x	Oil pump faulty	Replace oil pump
	2 x	Nozzle blocked	Replace nozzle
External light during the pre-purge phase	4 x	Oil pump solenoid valve fails to close	Replace oil pump
	4 x	Flame monitor faulty	Replace flame monitor
	4 x	Ignition electrodes incorrectly adjusted or worn	Check the ignition electrodes; replace if necessary



Diagnosis (cont.)

Fault	Red flash code	Cause of fault	Measure
Burner starts and flame builds, but burner enters fault state after safety time expires	2 x	Flame monitor contaminated	Clean flame monitor
	2 x	Flame monitor receives insufficient light	Clean sensor plate
	2 x	Flame monitor faulty	Replace flame monitor
	2 x	Burner control unit faulty	Replace burner control unit
	2 x	Carbon deposits on the flame tube or on the sensor plate	Clean the flame tube and sensor plate
Flame tears off more than 3 times during operation	7 x	Air in suction line	Seal line and filter
	7 x	Nozzle faulty	Replace nozzle
	7 x	Burner incorrectly adjusted	Set default values (see chapter "Standard values for burner adjustment")
	7 x	Sensor plate contaminated	Clean sensor plate
Ignition switches on during operation	7 x	Flame monitor contaminated	Clean flame monitor
	7 x	Sensor plate contaminated	Clean sensor plate
	7 x	Nozzle contaminated or faulty	Replace nozzle
Condensate backup in flue gas heat exchanger	7 x	Siphon or neutralising system contaminated	Clean siphon and neutralising system

Faults without flash code indication

Fault	Cause of fault	Measure
Burner does not start (no fault indication), indicator does not illuminate	No power	Check fuse or plug-in connector 150 in the control unit, the electrical connections, the setting of the ON/OFF switch on the control unit and the mains isolator
	High limit safety cut-out has responded	Press reset button at the boiler control unit
	The low water indicator has caused the system to shut down	Check the water level; top-up if necessary. Press the reset button on the burner.
	Servomotor faulty	Replace the servomotor
When changing from stage 1 to stage 2, the flame tears off and the burner starts again	Flame monitor contaminated	Clean flame monitor
	Inside of flame tube contaminated	Clean inside of flame tube
	Sensor plate contaminated	Clean sensor plate
	Faulty control unit	Replace control unit
	Solenoid valve stage 2 faulty	Replace solenoid coil
Burner sooty	Insufficient or excess air	Correct the settings. Check and clean impeller. Check fan pressure Check ventilation in installation room.
	Insufficient chimney draught	Check chimney and flue gas routing
	Nozzle faulty	Replace the nozzle, fit the correct nozzle (see chapter "Standard values for burner adjustment")
	The flame tube extension is missing	Install the flame tube extension
CO ₂ content too low	Incorrect setting	Check setting (see chapter "Standard values for burner adjustment")

Diagnosis (cont.)

Fault	Cause of fault	Measure
Excessive flue gas temperature	Excessive oil throughput	Match oil throughput to rated boiler heating output
	Boiler contaminated	Clean boiler and correct burner adjustment
	Air in flue gas heat exchanger	Vent flue gas heat exchanger
	Flue gas heat exchanger contaminated	Clean flue gas heat exchanger
	Not all consumers are connected to the flue gas heat exchanger	Connect consumers correctly
	Pump faulty: Insufficient throughput through the flue gas heat exchanger	Replace the pump.
Burner operates, constant red flickering light on the burner control unit	Not a fault; interface diagnosis was activated accidentally.	Press the reset button for >3 s until the LED illuminates yellow, then release
Condensate backup in flue gas heat exchanger	Siphon or neutralising system contaminated	Clean siphon and neutralising system

Component overview

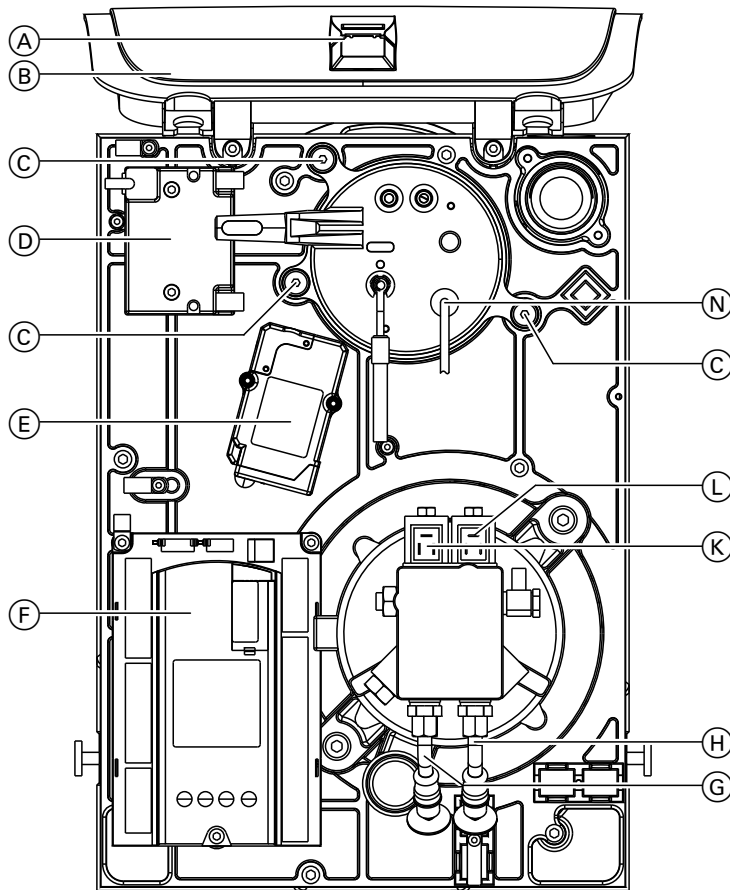

Fig. 15

- (A) Service switch (for burner adjustment)
- (B) Hood adaptor
- (C) Quick-action fastener
- (D) Electronic ignition
- (E) Servomotor
- (F) Burner control unit
- (G) Return line or suction line (differs subject to manufacturer)
- (H) Suction line or return line (differs subject to manufacturer)
- (K) Solenoid valve, stage 2
- (L) Solenoid valve, stage 1
- (N) Flame monitor

Component overview (cont.)

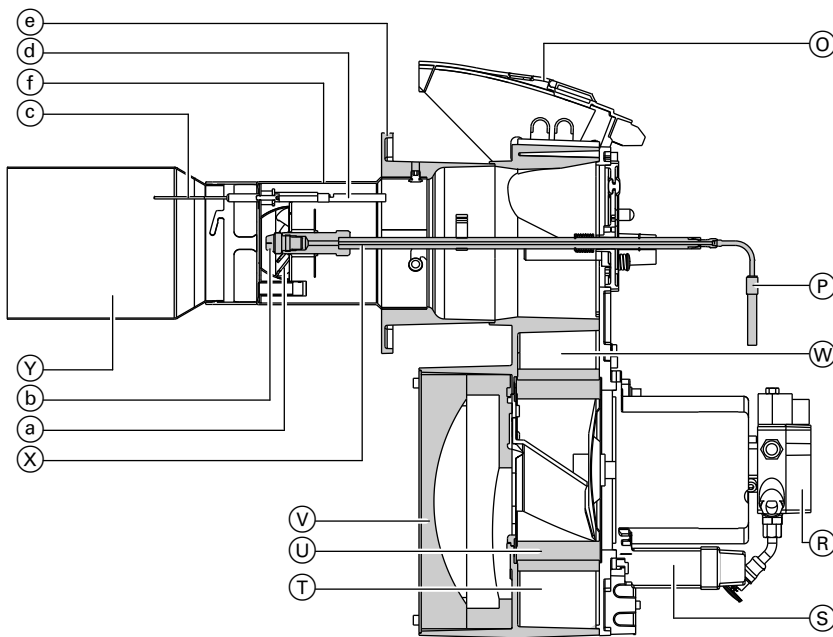

Fig. 16

- | | |
|------------------------|-------------------------|
| ⓪ Reset button | ⓧ Blast tube connection |
| Ⓟ Oil line | Ⓨ Flame tube |
| Ⓡ Oil pump | ⓐ Mixing device |
| Ⓢ Fan motor | ⓑ Oil burner nozzle |
| Ⓣ Fan casing | ⓒ Ignition electrodes |
| Ⓤ Impeller | ⓓ Ignition cable |
| Ⓥ Inlet air silencer | ⓔ Flange |
| Ⓦ Air regulating valve | ⓕ Adaptor pipe |

Connection and wiring diagram

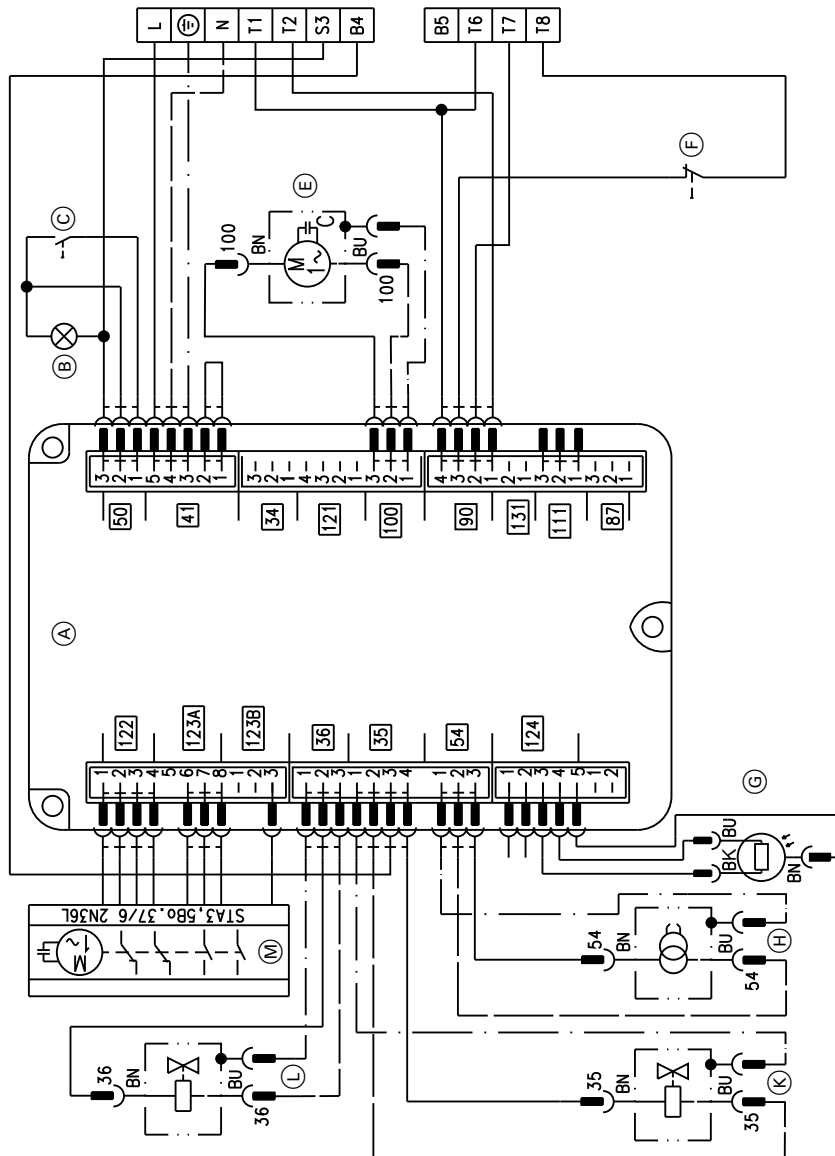

Fig. 17

- (A) Burner control unit (see chapter "Program sequence during commissioning")
- (B) Fault indicator
- (C) Reset button
- (E) Burner motor
- (F) Service switch (burner stage 2)
- (G) Flame monitor
- (H) Electronic ignition
- (K) Fuel valve (BV1)
- (L) Fuel valve (BV2)
- (M) Servomotor for rotary damper

Colour coding to DIN IEC 60757

BK	Black
BK*	Black wire with imprint
BN	Brown
BU	Blue
GN/YE	Green/yellow
RD	Red

Report			Commissioning	Maintenance/Service
Settings and test values (Set values, see chapter "Standard values for burner adjustment", page 27)				
Oil pressure				
▪ Stage 1	actual	bar		
	set	bar		
▪ Stage 2	actual	bar		
	set	bar		
Vacuum				
	actual	bar		
	after maintenance	bar		
Soot value				
▪ Stage 1	actual			
	after maintenance			
▪ Stage 2	actual			
	after maintenance			
Carbon dioxide content CO₂				
▪ Stage 1	actual	% by vol.		
	set	% by vol.		
▪ Stage 2	actual	% by vol.		
	set	% by vol.		
Oxygen content O₂				
▪ Stage 1	actual	% by vol.		
	set	% by vol.		
▪ Stage 2	actual	% by vol.		
	set	% by vol.		
Flue gas temperature (gross)				
▪ Stage 1	actual	°C		
	set	°C		
▪ Stage 2	actual	°C		
	set	°C		
Flue gas loss				
▪ Stage 1	actual	%		
	set	%		
▪ Stage 2	actual	%		
	set	%		
Draught (at the back of the boiler)				
	actual	hPa		
	set	hPa		
Hours run meter reading				
▪ Stage 1	actual	h		
▪ Stage 2	actual	h		

Specification

Specification

Rated boiler heating output				
$T_F/T_R = 50/30\text{ °C}$	kW	67.6	85.8	107.3
$T_F/T_R = 80/60\text{ °C}$	kW	63	80	100
Rated burner heat input stage 1/2^{*1}	kW	45.9/65.6	58.3/83.3	72.9/104.2
Burner type		VHG III-1	VHG III-2	VHG III-3
DIN registration no.		Applied for		
Voltage	V	230		
Frequency	Hz	50		
Power consumption	W	Stage 1: 585 Stage 2: 616		
Motor speed	rpm	2800		
Version		2-stage		
Oil pump rate	l/h	70		
Connections	R (female thread)	¾		
Suction and return line on the supplied oil hoses				
Max. permissible pre-charge pressure in the supply lines (with ring pipelines)		2		

^{*1} Corresponds to the rated heat input of the boiler.

Standard values for burner adjustment

Rated heating output of the boiler						
$T_F/T_R = 50/30$ °C	kW		67.6	85.8	107.3	
$T_F/T_R = 80/60$ °C	kW		63	80	100	
Oil burner nozzle						
Make: Danfoss	Type		80°H	80°H	80°H	
	Gph		1.0	1.35	1.75	
Oil pressure approx.^{*2}						
Stage 1	bar min.		12.5	11.0	12.5	
Stage 2	bar		24.0	21.0	20.0	
Oil throughput						
Stage 1	kg/h		3.6	4.9	6.2	
	l/h		4.6	5.7	7.2	
Stage 2	kg/h		5.5	7.0	8.8	
	l/h		6.5	8.2	10.3	
Position of the switching cams at the air damper servomotor^{*3}						
SL	°		8	11	10	
ST 1	°		9	12	11	
ST 2	°		50	50	50	
BV	°		30	30	30	
Inlet air aperture setting				5	5	5
Static burner pressure^{*4}	Stage 1	mbar	12.0	15.5	15.5	
	Stage 2	mbar	22.5	25.5	22.5	

^{*2} Due to nozzle tolerances and varying oil characteristics, the oil pressure may vary from the specified values.

^{*3} The air damper servomotor is factory-set and must only be adjusted in exceptional cases. Exceptions are the replacement of the air damper servomotor, soot build-up and the altitude above sea level of the installation site.
The CO₂ value must only be adjusted by regulating the oil pressure.

^{*4} Standard values for checking the burner adjustment

Information on fuel oil

Fuel oil quality

The Vitoflame oil burner is approved for the combustion of all commercially available fuel oils EL according to DIN 51603-1. Also for fuel oil DIN 51603-6 EL A Bio 10 (low sulphur with mixtures of up to 10 % bio-components).

A condensate neutralising system is not required (according to Code of Practice ATV-DVWK-A 251 [Germany]) when using low sulphur fuel according to DIN 51603.

Fuel oil additives

Fuel oil additives are substances that can be added providing they offer the following characteristics:

- Improvement of stability during fuel storage.
- Improvement of the thermal stability of the fuel.
- Reduction of odour development during tank filling.

! Please note

- Fuel oil additives can create residues and impair the safe operation of your heating system. The use of fuel oil additives that leave residues is not permitted.

Combustion improvers

Combustion improvers are additives for optimising fuel oil combustion.

Viessmann oil burners do not require combustion improvers, as these burners operate with clean and efficient combustion.

! Please note

- Combustion improvers can create residues and impair the safe operation of your heating system. The use of combustion improvers that leave residues is not permitted.

Biofuels

Biofuels are made from vegetable oil, e.g. sunflower or rape seed oil.

! Please note

- Biofuels can lead to damage to Viessmann oil burners. Their use is not acceptable.

Keyword index

A		Flame monitor, safety check.....	11
Additives for fuel oil.....	28	Flash code.....	19
Air damper position.....	10	Flowchart, burner faults.....	18
Air damper servomotor, checking settings.....	10	Fuel oil	
		– Additives.....	28
		– Quality.....	28
B		I	
Biofuels.....	28	Ignition air setting.....	10
Burner cleaning.....	12	Ignition electrodes, checking and adjusting.....	13
Burner control unit		N	
– Burner fault flowchart.....	18	Nozzle replacement.....	13
– Function and fault displays of signal indicator (LED)..	16	O	
– Program sequence during commissioning.....	16	Oil pressure, adjusting.....	8
Burner fault flowchart.....	18	Oil pump filter cleaning, and replacing if necessary...	14
C		R	
Combustion improvers.....	28	Report.....	25
Component overview.....	22	S	
Connection and wiring diagram.....	24	Specification.....	26, 27
D		Standard values for burner adjustment.....	27
Diagnosis		System commissioning.....	8
– Faults with flash code indication.....	19	V	
– Faults without flash code indication.....	20	Vacuum, checking.....	8
F			
Flame monitor			
– Installation and adjustment.....	11		
Flame monitor, cleaning and testing.....	11		





Viessmann Werke GmbH & Co. KG
D-35107 Allendorf
Telephone: +49 6452 70-0
Fax: +49 6452 70-2780
www.viessmann.com



Viessmann Limited
Hortonwood 30, Telford
Shropshire, TF1 7YP, GB
Telephone: +44 1952 675000
Fax: +44 1952 675040
E-mail: info-uk@viessmann.com

5834343 Subject to technical modifications.