



Delta HP VIP Installation Manual

For capacities 200, 250 and 300 litres

This cylinder is manufactured and approved in accordance with EN 12897 : 2006



142226-00 DGC 10-2016

Contents	Page no.
1. General information	2
2. Preparation of installation area.....	4
3. Pipe connections.....	4
4. Commissioning and filling up.....	5
5. Draining and Flushing.....	5
6. Electrical Installation.....	5
7. Safety and Servicing.....	9
8. Fault finding.....	10
9. Technical and Performance specs...	11
10. Log book.....	13



Thank-you for purchasing the Delta HP VIP unvented hot water cylinder.

Delta HP VIP is an unvented hot water cylinder in capacities 200, 250 and 300 litres. Its energy efficiency as defined by standing heat losses is the best in its class due to the use of vacuum insulated Panels (VIP) and will save the householder significant energy costs over the lifetime of the cylinder.

This manual gives detailed advice for installation and should be read carefully prior to fitting any unvented unit. OSO Delta HP VIP cylinders are not suitable for gravity fed primary systems. In known hard water regions, precautions should be taken to prevent limescale formation in hot water cylinders, in accordance with Building Regulation Part L, Domestic Heating Compliance Guide.

This OSO cylinder must be installed by a competent person and be installed in compliance with the OSO Installation and Maintenance Instructions, all current legislation, codes of practice and regulations governing the installation of unvented hot water cylinders in force at the date of installation.

PLEASE READ THIS MANUAL BEFORE INSTALLATION AND LEAVE WITH THE CYLINDER . THE MANUAL AND ATTACHED LOGBOOK SERVE AS THE CYLINDER GUARANTEE.

1. General information

1.1 Health and Safety regulations.

Handling Operations Regulations 1992 defines manual handling as: “any transporting or supporting of a load (including the lifting, putting down, pushing, pulling, carrying or moving thereof) by hand or bodily force” The Regulations set no specific requirements such as weight limits. However common sense still has to be used based on an ergonomic approach for each individual.

The Delta HP VIP should be transported and stored in a vertical position

1.2 Siting the Delta HP VIP .

There are few restrictions on the siting of the OSO Delta HP VIP, however it should not be sited anywhere open to frost attack. The unit should be placed on a stable flat surface capable of withstanding the weight of the cylinder when full (see technical data on page 11) and access must be allowed for maintenance purposes. If wall mounted with an OSO wall bracket, the wall should be capable of withstanding the forces generated by the weight of the full cylinder. Provision should also be allowed for the routing of the discharge pipe away from the cylinder to an outside point according to building regulation G3. (See page 10)

1.3 Component Check list

Components supplied with the unit in a separate accessory kit for site fitting:

Multibloc valve, includes pressure reducing valve, line strainer, balanced cold water take off,(for shower or bidet only) check and expansion valve.

Tundish

3/4” x 22mm Elbow / Drain Cock

Motorised valve

Expansion vessel.

1.4 Components factory fitted

Immersion heater

Thermostats / thermal cut-out

Temperature and pressure relief valve.

1.5 Documentation supplied - Installation manual & log book

1.6 Supply requirements

An uninterrupted 22mm cold water mains supply is recommended, however if only a 15mm supply is available, this may be used provided there is sufficient flow rate available, a minimum standing pressure of 2.5 bar and a flow rate of 20 litres per minute with a 1 bar dynamic pressure is recommended. The cylinder will operate at lower pressures and flow rates however the performance will be compromised. The OSO unvented unit is designed for use with supply pressure up to 10 bar. For pressures over 10 bar an additional pressure reducing valve must be fitted in the supply pipe to the unit.

1.7 Expansion vessels

The vessel accommodates expanded water when the cylinder is heated and prevents the cylinder reaching its maximum working pressure.

1.8 Compatible fittings and components

All thermostatically controlled boilers are compatible with indirect OSO cylinders. Heat sources to unvented hot water cylinders must be controlled by a thermal cut-out as well as a thermostat. The OSO Ecoline GEO is supplied with sensor bosses and pockets to house temperature sensors linked to the heat pump.

General Layout

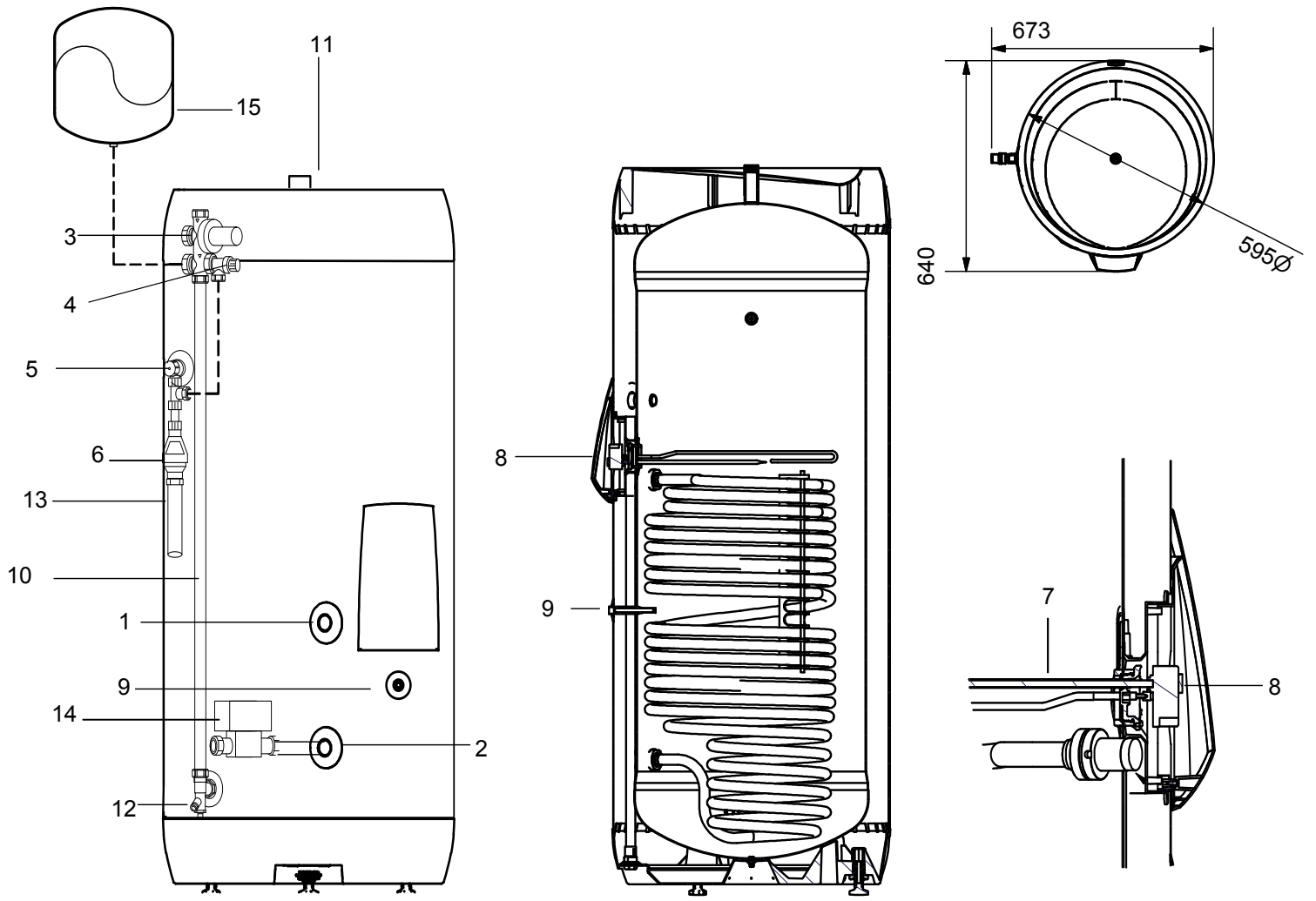

KEY

Part No.

1	Return 3/4" BSP Heat Pump	
2	Flow 3/4" BSP Heat Pump	
3	Pressure Reducing Valve Multibloc (3 bar) Includes Item 4	355030
4	Expansion relief valve (6 bar)	PRE355030
5	Temperature and Pressure Relief Valve	550853
6	Tundish	219005
7	Immersion Heater	71242
8	Immersion Heater Control Thermostat	80314
9	Indirect Control Thermostat	80345
10	Cold Feed Tube (Not supplied see Table 1)	

KEY

Part No.

11	Hot Water Outlet 3/4" BSP	
12	Elbow / Drain Cock	250445
13	Discharge Pipe (Not supplied)	
14	Motorised Valve (Not Factory Fitted)	92000
15	Expansion vessel	AX 18 or 24

TABLE 1

Size	Length of tube (ø22) mm	Exp. vessel pre charge/ size
200	940	3 bar/18 litre
250	1210	3 bar/24 litre
300	1420	3 bar/24 litre

2. Preparation of installation area

2.1 Positioning the unit

The water heater should be fitted level on a hard surface with sufficient load strength to take the full weight of the cylinder (see technical data table page 11). There are no limitations regarding the fitting distance from walls etc., but it is strongly recommended to ensure easy access to all pipe fittings etc. The Temperature and Pressure relief valve and immersion heater are positioned at 90° apart. The Delta HP VIP cylinder must be positioned to ensure that the tundish is visible and there is easy access to the thermostat and to remove the immersion heater if required.

2.2 Protection from frost

If the water heater is in danger of being exposed to frost while not operating under electric power, the unit must be drained to avoid damage. Make sure the electric power is turned off before draining, otherwise the heating elements can be damaged and the warranty is void. Draining instructions, see "Draining" on page 5.

3. Pipe Connections

3.1 Cold water supply

3.1.2 To obtain the best performance from your OSO unvented system it is advisable to feed the unit with an uninterrupted supply.

3.1.3 Before connecting to the multibloc, flush the cold supply pipework of all flux and debris.

3.1.4 Locate the water heater in a suitable position to facilitate the installation of the cold water supply, discharge fittings and pipework. Also take into account access to the immersion heater.

3.1.5 Fit the combined male elbow drain cock to cold supply point (12), so that the compression fitting is vertical.

3.1.6 Fit the length of copper tube 22mm specified in Table 1 to the cold feed elbow (see 3.1.5 above) to include a Tee piece if a secondary return is required.

3.1.7 Fit the Multibloc(3) to the top of the copper tube (see 3.1.6 above).

3.1.8 Connect 15mm copper tube from the expansion relief valve (4) and also from the T & P valve (5) and join together in a Tee as shown on page 3.

3.1.9 Fit the tundish (6) to the bottom connection of this tee.

3.1.10 Connect the cold supply to the multibloc(3).

3.1.11 Fit the expansion vessel to the wall close to the water heater using the enclosed mounting bracket. Connect the expansion vessel to the multibloc, as shown on page 3.

3.2 Hot water supply

Connect the hot water supply pipe to the outlet (11). Ensure connection is water tight.

3.3 Balanced cold water supply (optional).

If no balanced cold supply is required, tighten the supplied blanking cap. If a balanced mains pressure cold water supply is required to a shower or bidet (over rim type only, ascending spray type requires type AA,AB or AD air gap), remove blanking cap and connect to the shower or bidet cold supply on the multibloc valve (3).

(Major shower manufacturers advise fitting a mini expansion vessel in the balanced cold supply pipework to accommodate thermal expansion and prevent tightening of shower controls) Using the balanced cold connection to feed bath taps can reduce the flow available to the unvented cylinder.

3.4 Secondary return (optional)

Connect secondary return if required to the Tee piece in the cold feed tube see diagram on page 12

3.5 Discharge pipe

Connect the tundish outlet to the discharge pipe. Install the Tundish in a vertical position within a maximum of 600 mm from the Temperature and Pressure Relief Valve drain connection and away from electrical components. Ensure the expansion relief pipework discharges through the tundish. Tundish pipework must be 22 mm with a minimum vertical length of 300 mm below tundish. Maximum permitted length of 22 mm pipework is 9 m. Each bend or elbow is equivalent to 0.8 m of pipework. All pipework must have continuous fall and discharge in a safe, visible position. If any doubt, refer to Building Regulation G3. Discharge pipe must be dedicated to the cylinder and must not be used for any other purpose.

3.6 Primary Flow and Return and Motorised valve

3.6.1 The Heat Pump primary flow and return connections should be made connections 1 & 2. The motorized valve can be connected to either the primary flow or return pipe. The primary flow and return fittings are 3/4" BSP female. The valve has 22mm x copper connections. The direction of primary flow in the coil is bottom to top. The maximum operating temperature of the primary flow would typically be 82°C.

3.6.2 For electrical connection of the motorised valve and immersion heater, please read Electrical Installation Instructions. (Pages 5).

4. Commissioning and filling up

4.1 Commissioning

4.1.1 Check all connections for tightness.

4.1.2 Open hot water tap furthest away from the OSO water heater. Open the mains stop cock to fill the water heater. When water flows evenly from tap, allow to run for a few minutes to flush through any dirt, swarf or residue, then close the tap. Open successive hot taps to purge any remaining air.

4.1.3 Check all water connections for leaks and rectify if necessary.

Manually operate Expansion relief valve 4 (see page 3) to ensure free water flow through discharge pipe by turning knob counter-clockwise. To close continue to turn counter-clockwise until the valve shuts.

Manually operate Temperature and Pressure Relief Valve 5 (see page 3) to ensure free water flow through discharge pipe (Turn knob counter-clockwise).

Switch electrical power on.

5. Draining & flushing out the system.

5.1 Draining

Switch off the electrical power (Important to avoid damage to element). Isolate Heat Pump from OSO unit. Turn off the cold water supply valve. Open hot water tap. Open drain 12 (see page 3) at base of cylinder. The unit will drain. Draining process may be speeded up by opening the temperature and pressure relief valve. An internal $\varnothing 18$ mm hose can be applied to lead the water to a gully, sink or similar.

5.2 System flushing

This will not be necessary under normal circumstances as the line strainer will prevent ingress of foreign materials, however if flushing is required, run at least 50 litres of water from the cylinder at the highest possible flow rate. Close the taps and follow draining procedure (above).

6. Electrical installation - all wiring must conform to current IEE regulations

6.1 Immersion Heater Thermostat

The immersion heater is designed as an auxiliary heater as an emergency back-up. Power to immersion heaters should not be switched on until the unit is filled with water. All units are fitted with one 3 kW immersion heater which is located behind the electrical box. Alternative thermostats should not be used, regulations require immersion heaters on unvented cylinders to be connected with a thermal cut-out. Follow the wiring instructions below connecting the live, neutral and earth as indicated. The unit must be permanently connected to the electrical supply through a double-pole linked switch with a minimum break capacity of 13 amps. All internal wiring is factory mounted. Each immersion heater has a working thermostat adjustable between 18°C - 70°C (+/- 5°C). A safety cut-out is also incorporated within the thermostat and will operate at 87°C ($\pm 7^\circ\text{C}$). Should this happen, check reasons for thermal cut-out button being released and when satisfied press the reset button.

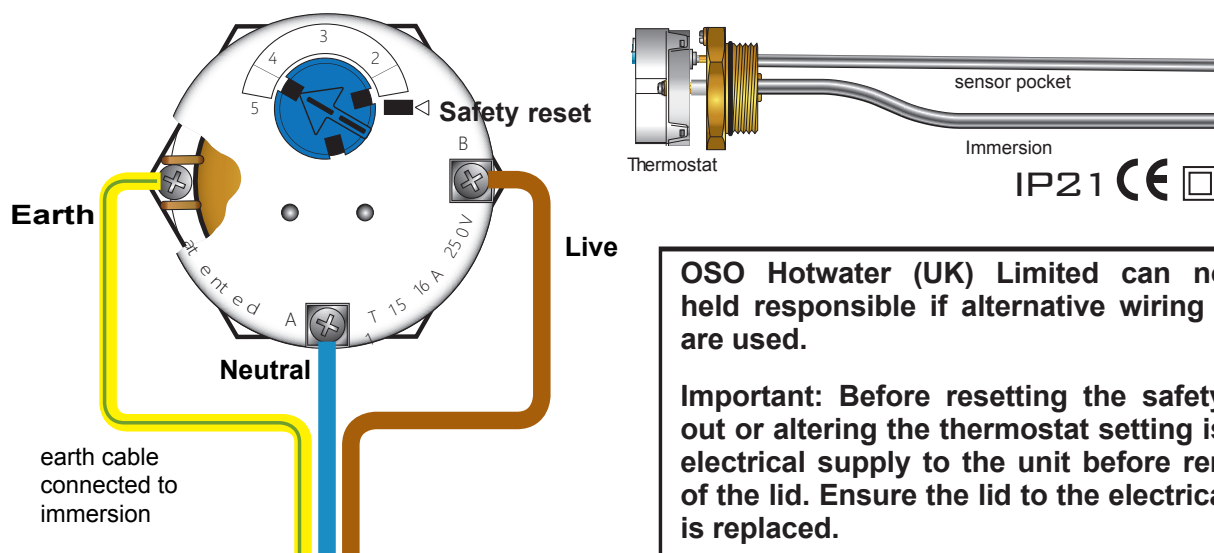

OSO Hotwater (UK) Limited can not be held responsible if alternative wiring plans are used.

Important: Before resetting the safety cut-out or altering the thermostat setting isolate electrical supply to the unit before removal of the lid. Ensure the lid to the electrical box is replaced.

Indirect Heating System

6.3 Motorised valve

To comply with regulations governing the installation of indirect unvented cylinders, a motorised valve must be fitted in the primary pipework. Your OSO unit has been supplied with a two port motorised valve, which will act as a positive energy cut-out should the safety cut-out operate. The motorised valve will also control the temperature of the domestic stored water via the cylinder thermostat, which is located in the electrical box. The unit can be installed on an "S" or "Y" plan system. Please follow the wiring instructions carefully.

6.4 Digital Dual Cylinder Thermostat

The Digital Dual Cylinder has real safety and energy saving benefits and provides accurate temperature control. It also features a clear and informative LCD display. Leave the cylinder thermostat set at 60°C in line with current government guidelines. Lowering the temperature will substantially reduce the amount of usable hot water available on a daily basis and could result in bacterial growth unless the legionella facility is activated (**THIS FUNCTION IS ACTIVATED AS STANDARD see label on side of thermostat, for commissioning purposes please disable this function selecting OF in display see 6.4.1 below**).

The legionella mode gives a weekly automatic one hour "boost" to above 60°C which kills any legionella bacteria, This function is adjustable allowing the duration of the legionella override to be adjusted from 1 to 7 days or completely disabled to operate as a conventional Dual Cylinder Thermostat. The LCD display shows the current water temperature and the user defined water temperature, while the red LED indicates that the unit is calling for heat. The sensitive electronic sensors operate at a far greater accuracy than conventional thermostats. The dial makes it easy to set the required controller temperature (between 25°C and 65°C). The second (limit) safety thermostat is pre-set to 80°C with a concealed manual reset, to comply with building regulations. Should the safety cut out be brought into operation, the motorised valve will operate and close down the primary flow to the cylinder. To reset the safety cut-out and the motorised valve the reset button must be pressed in.

Wiring Diagram

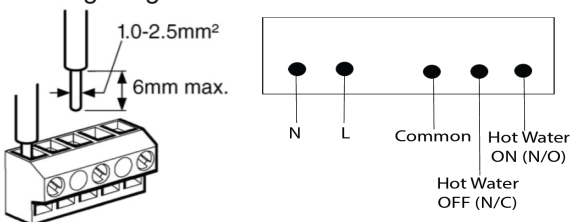

Also see S-Plan and Y Plan Wiring page 7 and 8

This product requires a fused permanent Live and Neutral supply.

6.4.1 Adjusting the 1 Hour Boost

The thermostat has user defined settings where the duration of the legionella Override/Boost can be adjusted from 1 to 7 days or completely disabled to operate as a conventional dual cylinder thermostat.

1. To disable or adjust the legionella override/boost turn the unit off by pressing and holding down the HOLIDAY button until an audible click is heard.
2. Release the button and after approx. 10 seconds press and hold the holiday button again until an audible click is heard and the **LCD display flashes**
3. Release the button and use the HOLIDAY button to choose between **disabling the override/Boost (OF in display)** or setting delay between boost/override from 1 - 7 days (1-7 in display)
4. Once selected release the button and the unit will return to the user set position within 5 seconds

6.4.2 Holiday Mode

This is the black button located under the display. Press and hold the holiday switch for a minimum of 10 seconds until you hear an audible click, and this switches the digital Dual Cylinder Thermostat off completely so there is no water heating and no weekly "boost" heating.

When in Holiday mode, the display is off. This feature should only be used when the property is vacant for extended periods and there is no requirement for water heating or for the weekly "boost". Pressing and holding the holiday switch again (for a minimum of 10 seconds until you hear an audible click) will restart the Electronic Dual Cylinder Thermostat, the display will show the cylinder temperature and the weekly

"boost" will immediately start, and recur every 7 days at the same time depending on the user set position.

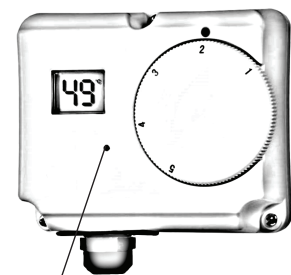

Holiday Mode

If using a 6-wire 28mm or 1" BSP V4043H on either circuit the white wire is not needed and must be made electrically safe.

OSO Hotwater (UK) Limited can not be responsible if alternative wiring plans are used. Important: Before resetting the safety cut-out or altering the thermostat setting isolate electrical supply to the unit before removal of the lid

S Plan Wiring

OSO Delta HP VIP cylinders can be fitted with all types of boilers. Standard Heat pumps operate using room and cylinder thermostats. Please follow upper diagram: 'Wiring for Standard Heat Pump'.

Thermistor controlled Heat Pumps Many popular Heat Pumps now use a thermistor principle. A thermistor temperature sensor is supplied with the Heat Pump to attach to the cylinder. Temperature information is relayed back to the Heat Pump control system. A Pocket is provided (see below to secure the sensor on the Delta HP VIP cylinder. The probe is run through a channel from base of cylinder to the immersion housing and housed there in a pocket. The thermistor cable should be secured using the supplied clamps in the bottom opening of the channel. The supplied motorised valve must be used in accordance with Building Regulation G3. This is wired from the supplied cylinder thermostat, wired as high limit stat. Please follow lower diagram: 'Wiring for Thermistor Controlled Heat Pump'.

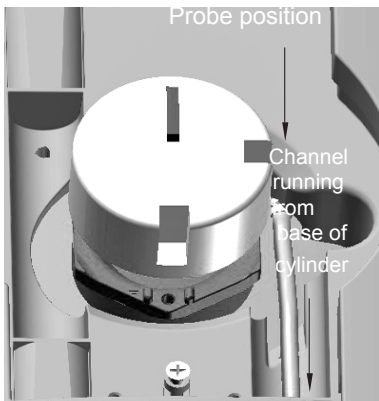

Using Cylinder Thermostat as high limit stat only - coil the grey temperature probe wire inside thermostat box and insert black probe into thermostat pocket of cylinder then turn dial on front to number 5

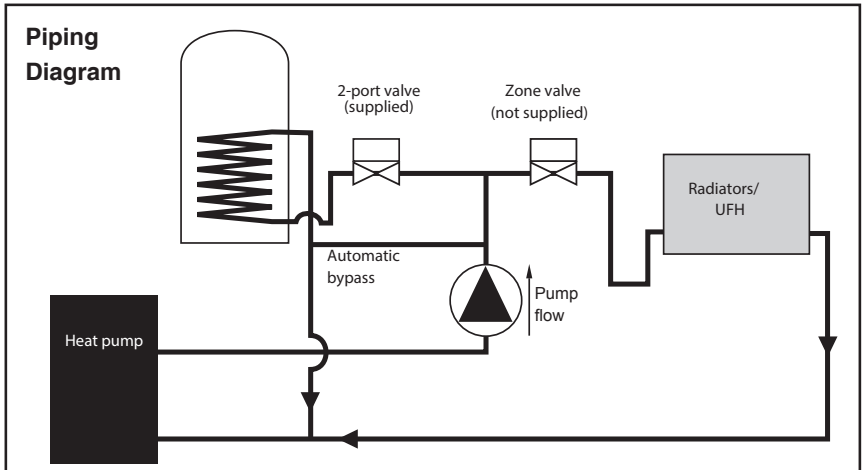
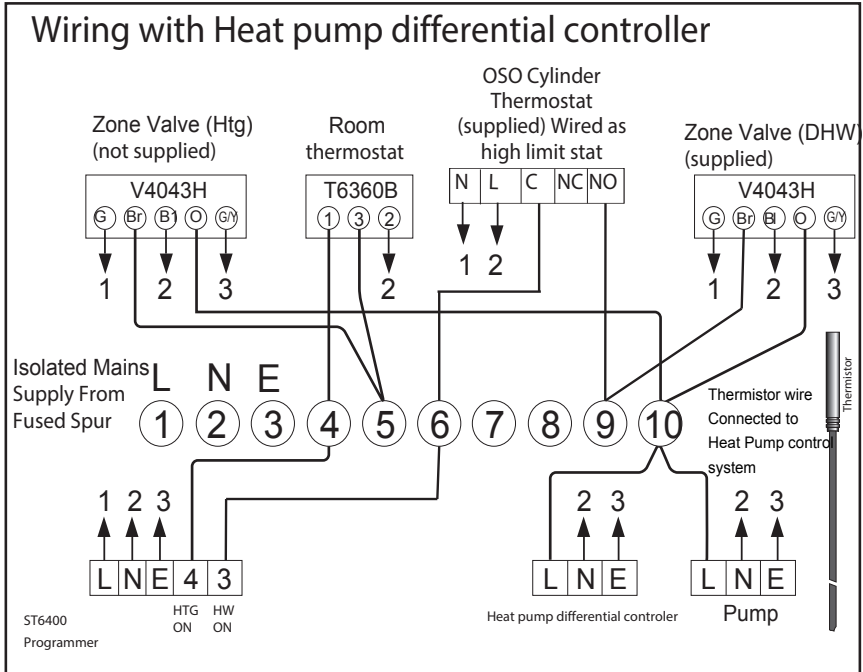
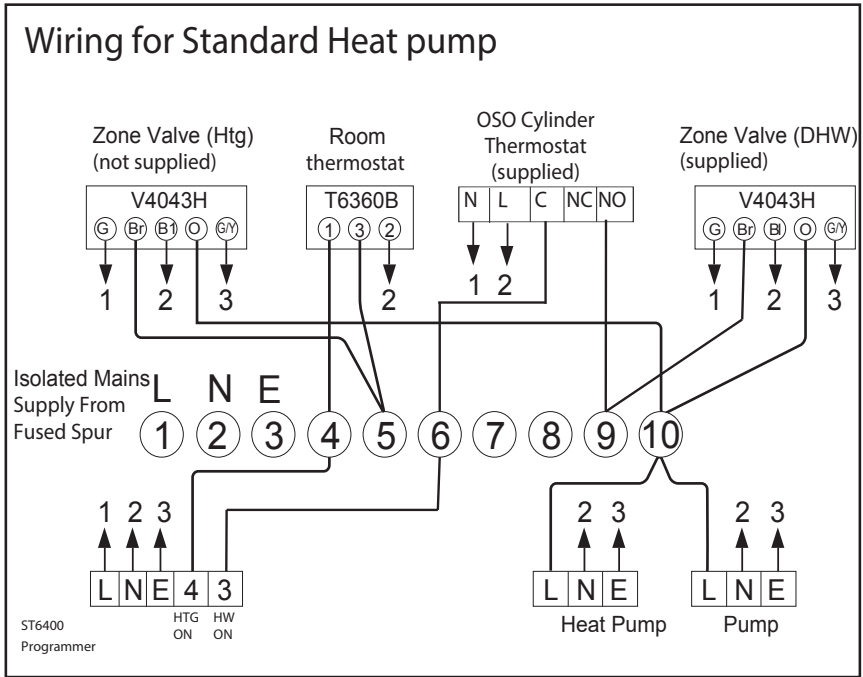

Y Plan Wiring

OSO Delta HP VIP cylinders can be fitted with all types of boilers. Standard boilers operate using room and cylinder thermostats. Please follow upper diagram: 'Wiring for Standard Heat Pump'.

Thermistor controlled boilers

Many popular Heat pumps now use a thermistor principle. A thermistor temperature sensor is supplied with the Heat Pump to attach to the cylinder. Temperature information is relayed back to the Heat Pump control system.

A Pocket is provided (see below to secure the sensor on the Delta HP VIP cylinder. The probe is run through a channel from base of cylinder to the immersion housing and housed there in a pocket. The thermistor cable should be secured using the supplied clamps in the bottom opening of the channel. The supplied motorised valve must be used in accordance with Building Regulation G3. This is wired from the supplied cylinder thermostat, wired as high limit stat. Please follow lower diagram: 'Wiring for Thermistor Controlled Heat Pump'.

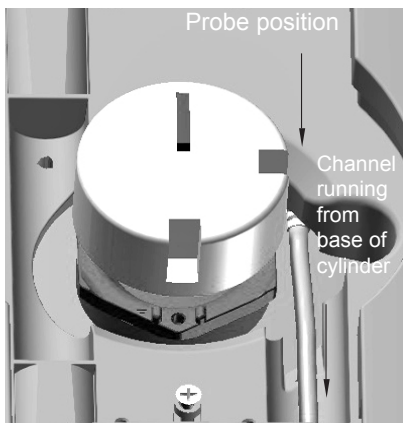

Using cylinder thermostat as high limit stat only - coil the grey temperature probe wire inside thermostat box and insert black probe into thermostat pocket of cylinder then turn dial on front to number 5

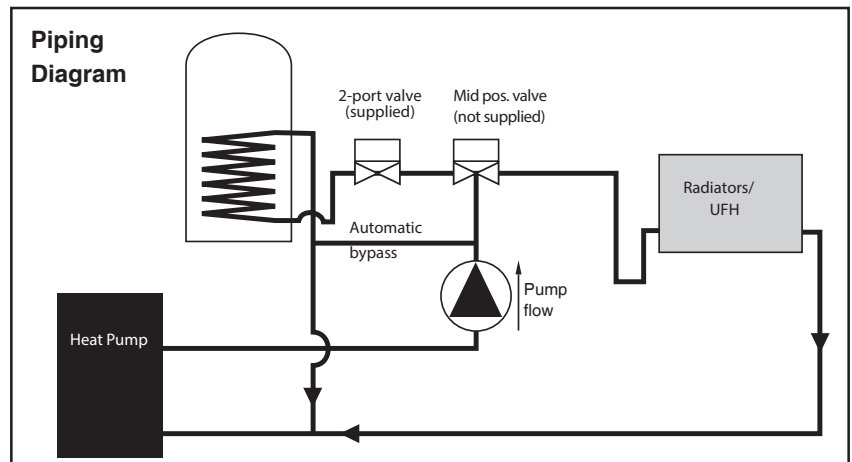
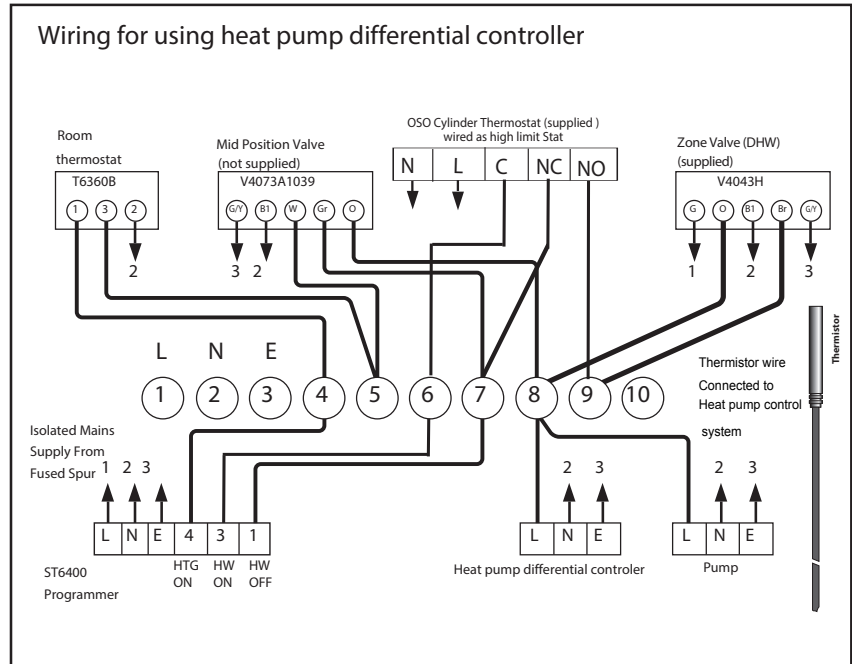
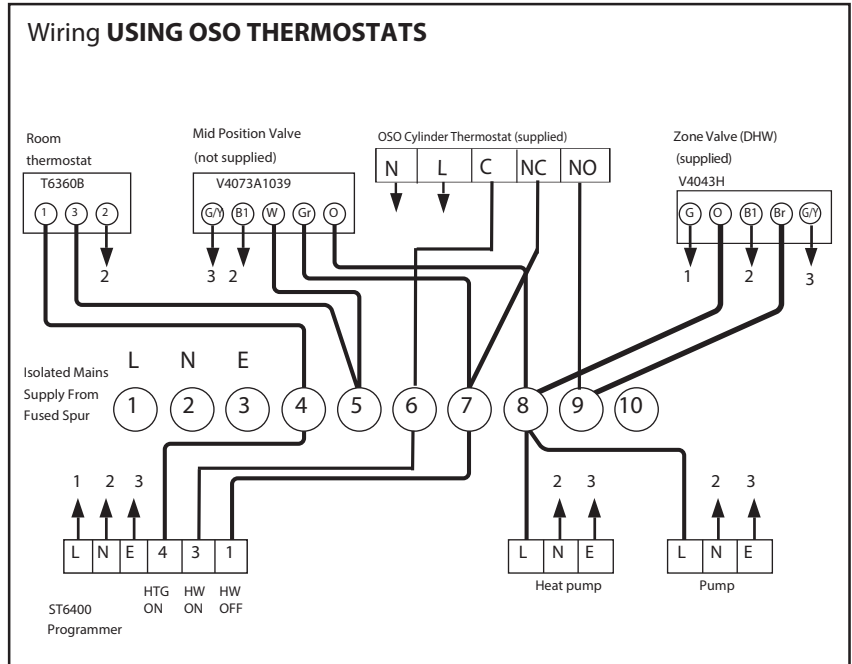

7. Safety and Servicing

Maintenance must be carried out by a competent person.

7.1 Safety Cut-out

The safety cut-out operates if:

1. Wiring is incorrect.
2. The immersion heater thermostat or cylinder thermostat fails.
3. Thermostat is set too high.
4. Remember before resetting the safety cut-out or altering the thermostat setting, isolate electrical supply to the unit prior to removal of the electrical box lid.
5. Reduce thermostat setting and press the reset button. After adjustments are completed, ensure the lid to the electrical box is replaced.
6. If still out of operation, contact installer.

7.2 Intermittent or slow discharge from tundish

1. Turn off the electrical supply to the immersion heaters.
2. Turn off cold water supply valve.
3. Open a hot tap.
4. Turn the knob on the Temperature and Pressure Relief Valve (5) to the left and hold in this position for thirty seconds.
5. Attach a foot pump with a schraeder (car type) valve to the expansion vessel.
6. Pump up to 3 bar
7. Open cold water supply valve.
8. When water flows through open tap, close tap
9. Turn on electrical supply to the immersion heaters.

7.3 Continuous very hot water discharge from tundish

This indicates a malfunction of a thermal cut-out, operating thermostat or the combined temperature and pressure relief valve. Turn off the electrical supply to the immersion heater and also isolate an indirect unit from the Heat Pump. Contact the installer or competent engineer.

7.4 Expansion vessel maintenance

The expansion vessels do not require annual maintenance and should not be tampered with unless an intermittent or slow discharge from the tundish occurs when water is being heated. In this situation, maintenance must be carried out by competent person and the precharge pressure must be restored to the original value. An annual visual inspection is recommended. Important: To check the precharge the expansion vessel must be completely empty of water. If the precharge pressure is different from the value shown on the label it must be restored to the original value.

Do not remove expansion vessel without depressurising the cylinder and draining 10 litres of water from the drain valve at the base of the cylinder.

7.5 Guarantee

Cylinder should be serviced annually and the log book should be updated in order to validate guarantee. The log book and service records act as guarantee document. For terms of guarantee please see the log book on page 15.

7.6 Servicing Procedure:

7.6.1 Expansion relief valve

Ensure that expansion relief valve works by manually opening to discharge water to tundish.

7.6.2 Pressure reducing valve

Isolate the cold water supply and open a ground floor cold tap. Unscrew the pressure reducing cartridge. Clean the filter mesh and the cartridge under running water. Replace cartridge ensuring that strainer is correctly located and reassemble the unit.

7.6.3 Expansion relief cartridge

Isolate the cold supply and open a ground floor cold tap. unscrew blue expansion relief headwork from valve body. Clean valve seat face and seating - do not scratch or damage either seat face or seating. Refit in reverse order. Do not overtighten.

7.6.4 Temperature and Pressure relief valve

Ensure that Temperature & Pressure Relief valve works by manually opening to discharge water to tundish.

7.6.5 Internal inspection

The immersion heater can be removed to provide visual inspection access to the cylinder.

8. OSO Fault Finding Guide

FAULT	POSSIBLE CAUSE	SOLUTION
No water flow from hot taps.	<ol style="list-style-type: none"> 1. Mains supply off. 2. Strainer blocked. 	<ol style="list-style-type: none"> 1. Check and open stopcock. 2. Turn off water supply. Remove strainer and clean (see Servicing Procedure page 9).
Water from hot taps is cold.	<ol style="list-style-type: none"> 1. Immersion heaters not switched on 9 (if in use) 2. Immersion heater thermal cut-out has operated (if in use) 3. Programmer set to central heating or not switched on. 4. Boiler not working. 5. Cylinder thermal cut-out has operated . 6. Motorised valve not operating correctly. 	<ol style="list-style-type: none"> 1. Check and switch on. 2. Check and reset button (under thermostat control knob) 3. Check and set to hot water. 4. Check Heat Pump operation. If fault suspected consult installer or Heat Pump manufacturer. 5. See 6.3 on page 7. 6. Check wiring and/or plumbing connections to motorised valve (see 3.6 on page 5 and wiring diagrams on page7 and 8.
Intermittent water discharge.	<ol style="list-style-type: none"> 1. Reduced expansion vessel charge. 	<ol style="list-style-type: none"> 1. Follow instruction page 9 "Intermittent or slow water discharge from tundish".
Continous water discharge.	<ol style="list-style-type: none"> 1. Thermal control failure (Note: Water will be hot). 2. Cold water inlet Pressure Reducing Valve not working. 3. Temperature and pressure relief valve faulty. 4. Expansion relief valve not working properly. 	<ol style="list-style-type: none"> 1. Switch off power to immersion heater and Heat Pump supply to the unit. When discharge has stopped, check thermal controls, replace if faulty. Contact a competent person. 2. Check pressure from valve, if greater than 3 bar replace (see page 9). 3. Replace valve (see page 9).

Important - note: Disconnect electrical supply before removing any electrical equipment covers.

Alternative Discharge

Discharge pipes should be in metal and dedicated to the unvented cylinder. The pipe should have a continuous fall and should terminate in a safe and visible place.

Downward discharges at low level, i.e. up to 100 mm above external surfaces such as car parks, hard standings, grassed areas etc. are acceptable providing that where children may play or otherwise come into contact with discharges, a wire cage or similar guard is positioned to prevent contact, whilst maintaining visibility.

Discharge at high level, i.e. into a metal hopper and metal down pipe with the end of the discharge pipe clearly visible (tundish visible or not) or onto a roof capable of withstanding high temperature discharges of water and 3 m from any plastics guttering system that would collect such discharges (tundish visible).

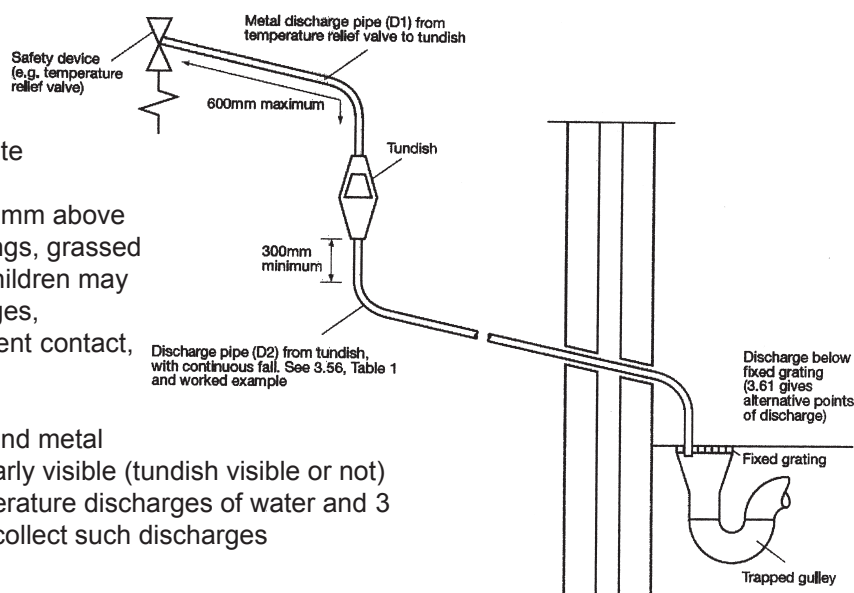

Where a single pipe serves a number of discharges, such as in blocks of flats, the number served should be limited to not more than 6 systems so that any installation discharging can be traced reasonably easily. The single common discharge pipe should be at least one pipe size larger than the largest individual discharge pipe to be connected. For further information contact your Building Control Office

Valve outlet size	Minimum size of discharge pipe D1*	Minimum size of discharge pipe D2* from tundish	Maximum resistance allowed, expressed as a length of straight pipe (i.e. no elbows or bends)	Resistance created by each elbow or bend
G1/2	15 mm	22 mm	up to 9 m	0.8 m
		28 mm	up to 18 m	1.0 m
		35 mm	up to 27 m	1.4 m
G3/4	22 mm	28 mm	up to 9 m	1.0 m
		35 mm	up to 18 m	1.4 m
		42 mm	up to 27 m	1.7 m
G1	28 mm	35 mm	up to 9 m	1.4 m
		42 mm	up to 18 m	1.7 m
		54 mm	up to 27 m	2.3 m

Technical Data - Delta Coil Heat Pump VIP

Description	Unit	DGC 200	DGC250	DGC300
Actual capacity of the water tank at 20°C	l	190,7	239,3	278,8
Outer diameter of the tank	mm	595	595	595
Height of the appliance	mm	1270	1540	1750
Gross weight of the appliance	kg	50	58	66
Net weight of the appliance	kg	47	54	62
Net weight of the appliance once filled with sanitary water	kg	246	306	351
Material of the tank / integrated heat exchanger	-	1.4521 / 1.4521	1.4521 / 1.4521	1.4521 / 1.4521
Material of element	-	incoloy 825	incoloy 825	incoloy 825
Thermal insulation material	-	PUR+VIP	PUR+VIP	PUR+VIP
Thermal insulation of the tank, average thickness	mm	50	50	50
IP classification	-	21	21	21
Standing heat loss /24hour	kWh/24h	1,03	1,12	1,18
Standing heat loss	Watts	43,0	46,8	49,0
Hot water capacity - mixed to 40°C	l	311	412	477
Heating time (upper Coil)	min	20,83	22,54	26,08
Reheat time (70%) (upper Coil)	min	14,6	15,8	18,3
Primary Heating Power (upper Coil)	kW	26	32	32
Primary flowrate for Reheat time and Primary heating power	l/h	900	900	900
Primary Heat exchanger pressure drop	mbar	100	120	120
Heat up time element	min	97	114	162
Reheat time (1) (70%) 1 element	min	68	79	114
ERP class	-	A	A	A
Pressure information				
Maximum design pressure of cylinder (rated pressure)	MPa /	1 / 10	1 / 10	1 / 10
Max. design pressure of heating coil	MPa /	1 / 10	1 / 10	1 / 10
operating pressure of cylinder	MPa /	3	3	3
operating pressure of heating coil	MPa /	2,5	2,5	2,5
Max. operating temperature of cylinder	°C	70	70	70
Max. operating temperature on the heating coil	°C	99	99	99
Expansion solution	-	Aquasystem 3 Bar	Aquasystem 3 Bar	Aquasystem 3 Bar
Expansion Vessel capacity	L	18	24	24
Exchanger information				
Primary Heat exchanger volume	l	7,7	9,9	9,9
Primary Heat exchanger surface area	m ²	1,4	1,8	1,8
∅ Int. et ∅ Ext.	mm/mm	∅20,4/∅22	∅20,4/∅22	∅20,4/∅22
Hydraulic connections				
Secondary return	mm	1/2"	1/2"	1/2"
Primary heat exchanger flow	inch	3/4"	3/4"	3/4"
Primary heat exchanger return	inch	3/4"	3/4"	3/4"
Cold water	inch	3/4"	3/4"	3/4"
Hot water	inch	3/4"	3/4"	3/4"
Immersion heater	inch	5/4"	5/4"	5/4"
Expansion Relief Valve	inch	1/2"	1/2"	1/2"
T & P Valve (Factory fitted)	inch	1/2"	1/2"	1/2"
Pressure reducing Valve	inch	3/4"	3/4"	3/4"
Temperature sensor sleeve diameter	mm	8	8	8
Electrical characteristics				
Supply voltage and frequency	V/Hz	230/50	230/50	230/50
Current	A	13	13	13
Power of the electrical resistance	W	3000	3000	3000
electrical installation	-	IEEE regs	IEEE regs	IEEE regs
Thermostat type - immersion/cylinder	-	Probe/Probe	Probe/Probe	Probe/Probe
Immersion capacity	Kw	3	3	3
Immersion Heater Phase	Phase	single	single	single
Immersion Heater - Voltage	Volt	230	230	230
immersion thermostat - temp range	°C	18-70	18-70	18-70
immersion thermostat - set temp	°C	60	60	60
Indirect thermostat - temp range	°C	25-65	25-65	25-65
Indirect thermostat - set temp	°C	60	60	60
Safety				
safety valve opening pressure +/- 5%	Bar	6	6	6
T & P Valve opening pressure/Temp	Bar/°C	10/90	10/90	10/90
safety thermostat cutout - immersion	°C	87	87	87
safety thermostat cutout - cylinder	°C	80	80	80
Packaging				
Width of Box	mm	610	610	610
Depth of Box	mm	610	610	610
Height of Box	mm	1320	1570	1780

Delta HP VIP Product Fiche

Data Reference	Supplier's Name	Model	ERP Class	Standing heat loss
200	OSO Hotwater	DGC200	A	43
250	OSO Hotwater	DGC250	A	48
300	OSO Hotwater	DGC300	A	52

Secondary Return

1. Secondary Return Fitting
2. Non Return Valve
3. Circulation Pump
4. Secondary Return Line
5. Hot water draw off to outlets

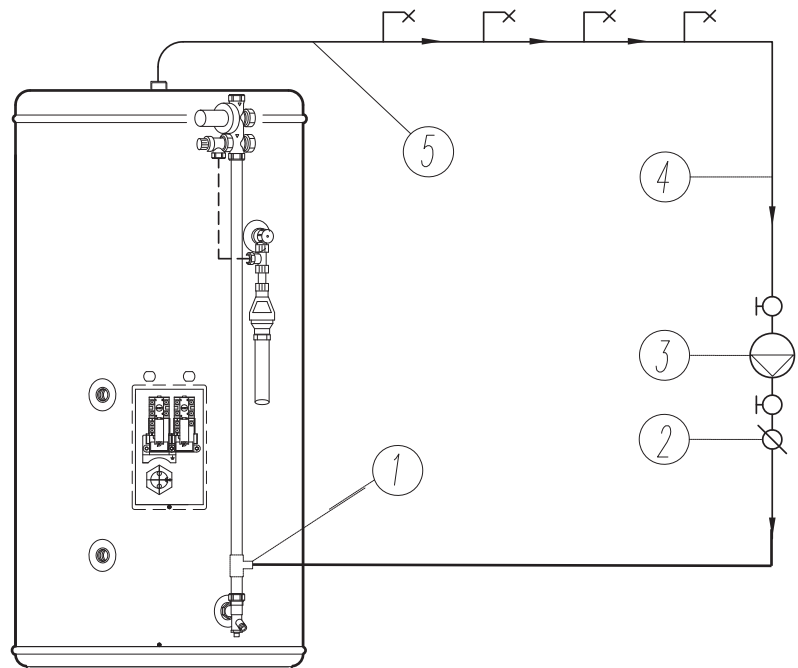

Description

Expansion valve
(Cartridge and seat)
Part No. 214005
6.0 Bar

Pressure reducing valve
Cartridge - Part No.
REDC 355030 - 3 bar

Expansion valve
6.0 Bar

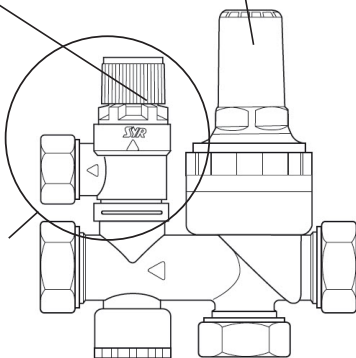

Expansion Relief Cartridge	214005
Expansion relief valve 8 bar	PRE355030
Multibloc	355030
Temperature & pressure relief valve	550853
Pressure Reducing Valve	REDC355030
Elbow Drain valve	250445
Immersion heater, Incoloy 3 kW	71242
Honeywell 2 port valve	92000
Fittings Kit	
Cylinder thermostat	80345
Immersion thermostat	80314
Expansion vessel	AX18, AX24

To obtain the address of a local stockist contact:

OSO HOTWATER (UK) LIMITED
 Endeavor House, Seventh Avenue, Team Valley
 Trading Estate, Gateshead, Tyne & Wear, NE11 0EF
 Phone: (0191) 482 0800 • Fax: (0191) 491 3655
 E-mail technical.uk@oso-hotwater.com
 E-mail spareparts.uk@oso-hotwater.com
 E-mail sales.uk@oso-hotwater.com

For Spares: www.oso-spares.co.uk

All replacement parts should be supplied by OSO HOTWATER (UK) LIMITED.

www.oso-spares.co.uk

IT IS THE RESPONSIBILITY OF THE INSTALLER TO COMPLETE THIS LOG BOOK AND PASS IT ON TO THE CUSTOMER. FAILURE TO DO SO MAY INVALIDATE THE CYLINDER GUARANTEE



The code of practice for the installation, commissioning & servicing of mains pressure hot water storage

Installation, Commissioning and Service Record Log Book

CUSTOMER DETAILS

NAME _____

ADDRESS _____

TEL No. _____

IMPORTANT

1. Please, keep the Log Book in a safe place for future reference.
2. This Log Book is to be completed in full by the competent person(s) who commissioned the equipment and then handed to the customer. When this is done, the Log Book is a commissioning certificate that can be accepted as evidence of compliance with the appropriate Building Regulations.
3. Failure to install and commission this appliance to the manufacturer's instructions may invalidate the guarantee.

The above does not affect your statutory rights.



© HEATING AND HOTWATER INFORMATION COUNCIL

HWA charter members agree to:

- To supply fit for purpose products clearly and honestly describe
- To supply products that meet, or exceed appropriate standards and building and water regulations
- To provide pre and post sales technical support
- To provide clear and concise warranty details to customers

For full details on the HWA charter please visit <http://www.hotwater.org.uk/>

INSTALLER & COMMISSIONING ENGINEER DETAILS

INSTALLER DETAILS

COMPANY NAME

DATE

ADDRESS

INSTALLER NAME

TEL No.

REGISTRATION DETAILS

REGISTERED OPERATIVE ID CARD No.
(IF APPLICABLE)

COMMISSIONING ENGINEER (IF DIFFERENT)

NAME

DATE

ADDRESS

TEL No.

REGISTRATION DETAILS

REGISTERED OPERATIVE ID CARD No.
(IF APPLICABLE)

GUARANTEE - OSO UNVENTED HOTWATER CYLINDER

The OSO stainless steel inner vessel is guaranteed against material defect or manufacturing faults for a period of 25 years from the date of purchase. All other parts including, but not limited to factory fitted electrical elements (damage caused by lime scale excluded), expansion vessel, thermostats and valves are guaranteed against material defects or manufacturing faults for 2 years from the date of purchase. In the event of a replacement component being required OSO Hotwater will supply such part(s) free of charge and freight paid, on condition that the defective component is delivered, freight paid to OSO Hotwater within 2 weeks of written notice being given to OSO Hotwater of the defect. Such replacement parts shall be guaranteed under the terms of this guarantee to the unexpired period of the aforementioned 2 year period.

This warranty is conditional upon the OSO cylinder being installed in compliance with the OSO Installation & Maintenance Instructions, all current legislation, codes of practice and regulations governing the installation of unvented hot water cylinders in force at the date of installation and provided that:

1. The water quality shall be in accordance with European Council Directive 98/83 EC, or revised version at the date of installation, and is not fed with water from a private supply.
Particular: Chloride content: Max. 250 mg/l
Sulphate content: Max. 250 mg/l
Combination Chloride/sulphate: Max. 300 mg/l (in total)
2. The OSO cylinder is filled with water before turning the electricity supply on to the heater elements.
3. The log book certificate is completed at the time of installation.
4. The OSO cylinder is serviced and maintained every 12 months and is marked as such in the logbook provided with the cylinder. Invoices for the maintenance work should be kept as proof of regular maintenance. Care should be taken of the logbook and invoices as they serve as the guarantee certificate for the cylinder.
5. If the newly fitted water heater is not in regular use then it must be flushed through with fresh water for at least 15 minutes Open at least one hot water tap once per week, during a period of at least 4 weeks.
6. The OSO unvented cylinder has not been modified in any way other than by OSO Hotwater and is only used for the storage of potable water.
7. No factory fitted parts have been removed for unauthorised repair or replacement.
8. Defects caused by frost, excess pressure, salt dehardner process, transient voltage, lightning strikes or incorrect installation, repair or use, are not covered by this warranty. A laboratory evaluation of possible defects can be ordered by the user, however the user must pay for this where the above mentioned conditions have not been fulfilled. Evidence of the purchase date and the date of supply must also be submitted with your claim.

This guarantee does not confer any rights other than those expressly set out above and does not cover any claims for consequential loss or damage. This guarantee is offered as an extra benefit and does not affect your statutory rights as a consumer.

IT IS THE RESPONSIBILITY OF THE INSTALLER TO COMPLETE THIS LOGBOOK AND PASS IT ON TO THE CUSTOMER. FAILURE TO DO SO MAY INVALIDATE THE CYLINDER GUARANTEE

APPLIANCE & TIME CONTROL DETAILS

MANUFACTURER OSO HOTWATER (UK)

MODEL

CAPACITY

litres

SERIAL No.

TYPE

UNVENTED

TIME CONTROL

PROGRAMMER

or

TIME SWITCH

COMMISSIONING PROCEDURE INFORMATION

Heat Pump PRIMARY SETTINGS (INDIRECT HEATING ONLY) ALL BOILERS

IS THE PRIMARY A SEALED OR OPEN VENTED SYSTEM?

SEALED

OPEN

WHAT IS THE Heat Pump FLOW TEMPERATURE?

°C

ALL MAINS PRESSURISED SYSTEMS

WHAT IS INCOMING STATIC COLD WATER PRESSURE AT THE INLET TO THE PRESSURE REDUCING VALVE?

bar

HAS STRAINER (IF FITTED) BEEN CLEANED OF INSTALLATION DEBRIS?

YES NO

HAS A WATER SCALE REDUCER BEEN FITTED?

YES NO

WHAT TYPE OF SCALE REDUCER HAS BEEN FITTED?

UNVENTED SYSTEMS

ARE COMBINED TEMPERATURE AND PRESSURE RELIEF VALVE AND EXPANSION VALVE FITTED AND DISCHARGE TESTED?

YES NO

IS PRIMARY ENERGY SOURCE CUT OUT FITTED (NORMALLY 2 PORT VALVE)?

YES NO

WHAT IS THE PRESSURE REDUCING VALVE SETTING (IF FITTED)?

bar

WHERE IS OPERATING PRESSURE REDUCING VALVE SITUATED?

YES NO

HAS THE EXPANSION VESSEL OR INTERNAL AIR SPACE BEEN CHECKED?

YES NO

WHAT IS THE HOT WATER TEMPERATURE AT THE NEAREST OUTLET?

°C

ALL PRODUCTS

DOES THE HOT WATER SYSTEM COMPLY WITH THE APPROPRIATE BUILDING REGULATIONS?

YES

HAS THE SYSTEM BEEN INSTALLED AND COMMISSIONED IN ACCORDANCE WITH THE MANUFACTURER'S INSTRUCTIONS?

YES

HAVE YOU DEMONSTRATED THE OPERATION OF THE SYSTEM CONTROLS TO THE CUSTOMER?

YES

HAVE YOU LEFT ALL THE MANUFACTURER'S LITERATURE WITH THE CUSTOMER?

YES

COMPETENT PERSON'S SIGNATURE

CUSTOMER'S SIGNATURE

(To confirm demonstrations of equipment and receipt of appliance instructions)

PLEASE FOLLOW THE INSTALLATION AND COMMISSIONING INSTRUCTIONS IN THE INSTALLATION MANUAL SUPPLIED WITH THE EQUIPMENT

SERVICE INTERVAL RECORD

It is recommended that your hot water system is serviced regularly and that your service engineer completes the appropriate Service Interval Record below.

SERVICE PROVIDER

Before completing the appropriate Service Interval Record below, please ensure you have carried out the service as described in the manufacturer's instructions and in compliance with all relevant codes of practice.

SERVICE 1	DATE:
ENGINEER NAME	
COMPANY NAME	
TEL No.	
COMMENTS	
SIGNATURE	

SERVICE 2	DATE:
ENGINEER NAME	
COMPANY NAME	
TEL No.	
COMMENTS	
SIGNATURE	

SERVICE 3	DATE:
ENGINEER NAME	
COMPANY NAME	
TEL No.	
COMMENTS	
SIGNATURE	

SERVICE 4	DATE:
ENGINEER NAME	
COMPANY NAME	
TEL No.	
COMMENTS	
SIGNATURE	

SERVICE 5	DATE:
ENGINEER NAME	
COMPANY NAME	
TEL No.	
COMMENTS	
SIGNATURE	

SERVICE 6	DATE:
ENGINEER NAME	
COMPANY NAME	
TEL No.	
COMMENTS	
SIGNATURE	

SERVICE 7	DATE:
ENGINEER NAME	
COMPANY NAME	
TEL No.	
COMMENTS	
SIGNATURE	

SERVICE 8	DATE:
ENGINEER NAME	
COMPANY NAME	
TEL No.	
COMMENTS	
SIGNATURE	

SERVICE 9	DATE:
ENGINEER NAME	
COMPANY NAME	
TEL No.	
COMMENTS	
SIGNATURE	

SERVICE 10	DATE:
ENGINEER NAME	
COMPANY NAME	
TEL No.	
COMMENTS	
SIGNATURE	

When all the above services have been completed, please contact your Service Engineer for an additional service interval record sheet.