

# Installation and service instructions

for contractors

# VIESSMANN

## Vitodens 100-W

Type **BPJA**, 6.5 to 25.0 kW

Wall mounted gas condensing boiler

Natural gas and LPG version

Gas Council no.: 41-819-30, 25 kW; 41-819-31, 29 kW

*For applicability, see the last page*



## VITODENS 100-W



## Safety instructions



Please follow these safety instructions closely to prevent accidents and material losses.

### Safety instructions explained



#### **Danger**

This symbol warns against the risk of injury.



#### **Please note**

This symbol warns against the risk of material losses and environmental pollution.

### **Note**

*Details identified by the word "Note" contain additional information.*

### **Target group**

These instructions are exclusively designed for qualified personnel.

- Work on gas equipment must only be carried out by a qualified gas fitter.
- Work on electrical equipment must only be carried out by a qualified electrician.
- The system must be commissioned by the system installer or a qualified person authorised by the installer.

### **Regulations**

Observe the following when working on this system

- all legal instructions regarding the prevention of accidents,
- all legal instructions regarding environmental protection,
- the Code of Practice of relevant trade associations,

- all current safety regulations as defined by DIN, EN, DVGW, TRGI, TRF, VDE and all locally applicable standards,
- Gas Safety (Installation & Use) Regulations
  - the appropriate Building Regulation either the Building regulations, the Building Regulation (Scotland), Building Regulations (Northern Ireland),
  - the Water Fittings Regulation or Water Bylaws in Scotland,
  - the current I.E.E. Wiring Regulations.

### **If you smell gas**



#### **Danger**

Escaping gas can lead to explosions which may result in serious injury.

- Never smoke. Prevent naked flames and sparks. Never switch lights or electrical appliances ON or OFF.
- Close the gas shut-off valve.
- Open windows and doors.
- Remove all people from the danger zone.
- Notify your gas or electricity supplier from outside the building.
- Shut off the electricity supply to the building from a safe place (outside the building).

## Safety instructions (cont.)

### If you smell flue gas



#### **Danger**

Flue gas can lead to life-threatening poisoning.

- Shut down the heating system.
- Ventilate the boiler room.
- Close all doors leading to the living space.

### Working on the system

- When using gas as fuel, also close the main gas shut-off valve and safeguard against unauthorised reopening.
- Isolate the system from the power supply and check that it is no longer 'live', e.g. by removing a separate fuse or by means of a main isolator.
- Safeguard the system against unauthorised reconnection.



#### **Please note**

Electronic modules can be damaged by electro-static discharges.

Touch earthed objects, such as heating or water pipes, to discharge static loads.

### Repair work



#### **Please note**

Repairing components which fulfil a safety function can compromise the safe operation of your heating system.

Replace faulty components only with original Viessmann spare parts.

### Ancillary components, spare and wearing parts



#### **Please note**

Spare and wearing parts which have not been tested together with the heating system can compromise its function. Installing non-authorised components and non-approved modifications/conversion can compromise safety and may invalidate our warranty. For replacements, use only original spare parts from Viessmann or those which are approved by Viessmann.

## Index

### Installation instructions

**Product information**..... 6

**Preparing for installation**..... 7

#### Installation sequence

Fitting the boiler and making connections..... 10

Opening the control unit casing..... 15

Electrical connections..... 16

### Service instructions

#### Commissioning, inspection, maintenance

Steps - commissioning, inspection and maintenance..... 19

Further details regarding the individual steps..... 20

#### Troubleshooting

Function sequence and possible faults..... 38

Fault messages on the display..... 39

Repairs..... 43

#### Gas type conversion

Converting from LPG to natural gas ..... 51

#### Designs

Connection and wiring diagram..... 53

#### Parts lists

Ordering parts..... 55

Overview of the assemblies..... 56

Sheet metal parts assembly..... 57

Heat cell assembly..... 58

Burner assembly..... 59

Hydraulic assembly..... 61

Combi hydraulic assembly..... 63

Control unit assembly..... 64

Miscellaneous assembly..... 65

**Specification**..... 66

#### Certificates

Declaration of conformity..... 67



**Index** (cont.)

**Keyword index**..... 68

## Product information

### Vitodens 100-W, type BPJA

Preset for operation with natural gas.  
Conversion to LPG P requires a gas conversion kit.

#### Conversion for other countries

The Vitodens 100-W should generally only be delivered to those countries specified on the type plate. For deliveries to alternative countries, an approved contractor, on his own initiative, must arrange individual approval in accordance with the law of the country in question.

#### Product description

The Vitodens 100-W is available as a gas condensing combi boiler with integral plate heat exchanger for DHW heating. For the connection of heating circuits and the DHW line, see from page 9.

The Vitodens 100-W is set up for operation with constant boiler water temperature.

The following are integrated: one sealed unvented hydraulic system with 2 connections for heating flow and return and 2 connections for DHW heating.

If the Vitodens 100-W is installed in an S plan or Y plan system, both of the internal connections must be sealed off, as they are not required.

The following components are integrated into the hydraulic system:

- Circulation pump
- 3-way diverter valve
- Safety valve
- Diaphragm expansion vessel
- Plate heat exchanger for DHW heating

#### Connection accessories

A time switch is connected with low voltage to the control unit.

## Preparing for installation

### Preparing for the boiler installation

#### Dimensions and connections

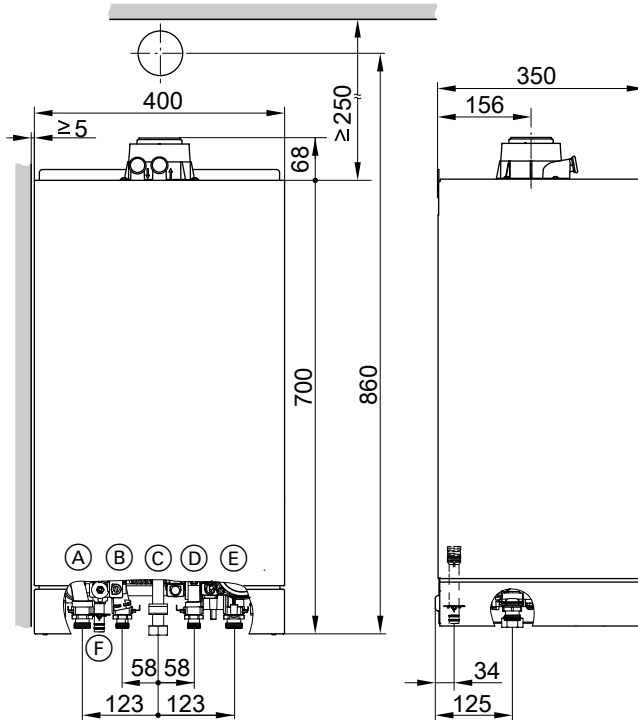

- (A) Heating flow  $\varnothing$  22 mm compression fitting
- (B) Hot water  $\varnothing$  15 mm compression fitting
- (C) Gas connection  $\varnothing$  22 mm
- (D) Cold water  $\varnothing$  15 mm compression fitting
- (E) Heating return  $\varnothing$  22 mm compression fitting
- (F) Condensate drain/safety valve drain: Plastic hose  $\varnothing$  22 mm

## Preparing for installation (cont.)

### Fitting the wall mounting bracket

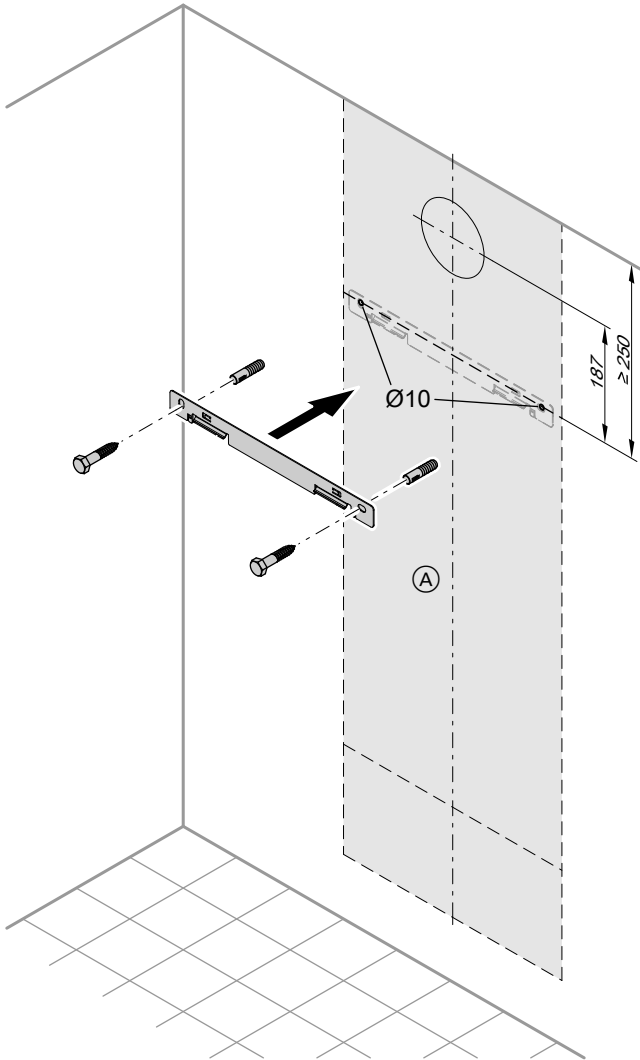

Ⓐ Vitodens installation template

## Preparing for installation (cont.)

1. Align the supplied installation template on the wall.
2. Mark out the rawl plug holes.
3. Drill  $\varnothing$  10 mm holes and insert the supplied rawl plugs.
4. Fit wall mounting bracket with screws supplied.

### Fit installation aid or mounting frame



Installation aid or mounting frame installation instructions

### Preparing the connections



#### **Please note**

To prevent equipment damage, install all pipework free of load and torque stresses.

1. Prepare the water connections. Flush the heating system.
2. Prepare the gas connection.
3. Prepare the electrical connections.
  - Power cable NYM-J 3 x 1.5 mm<sup>2</sup>.
  - Accessory cables: NYM-O 2-core min. 0.5 mm<sup>2</sup>.

## Fitting the boiler and making connections

### Removing the front panel and mounting the boiler

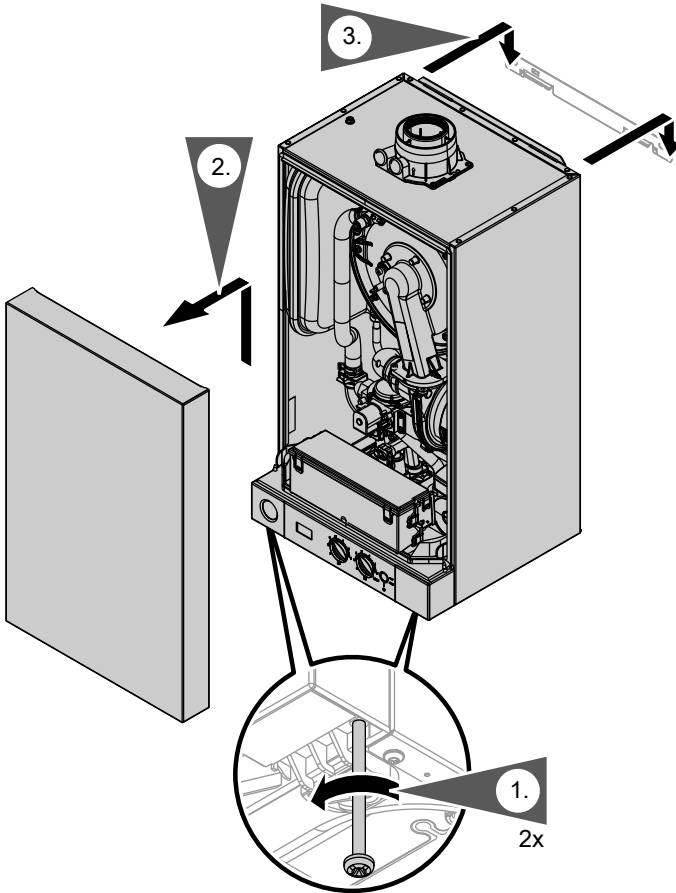

1. Undo screws at the bottom of the boiler; do not remove completely.

3. Hook the boiler into the wall mounting bracket.

2. Remove front panel.

## Fitting the boiler and making connections (cont.)

### Making connections on the water side

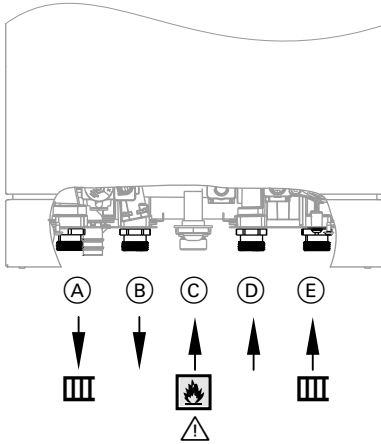

- (A) Heating flow G $\frac{3}{4}$
- (B) Hot water G $\frac{1}{2}$

- (C) Gas connection G $\frac{3}{4}$
- (D) Cold water G $\frac{1}{2}$
- (E) Heating return G $\frac{3}{4}$

 For fittings on the heating water side and DHW side, see separate installation instructions.

### Gas connection

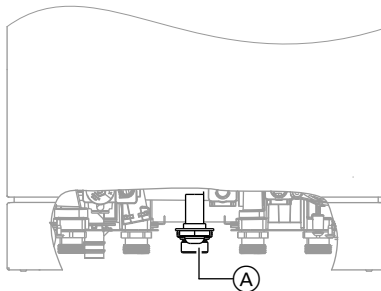

1. Connect gas shut-off valve to connection (A).



## Fitting the boiler and making connections (cont.)

2. Carry out a tightness test.

### **Note**

*For the tightness test, use only suitable and approved leak detecting agents (EN 14291) and devices.*

*Leak detecting agents with unsuitable contents (e.g. nitrites, sulphides) can result in material losses.*

*Remove residues of the leak detecting agent after testing.*



### **Please note**

Excessive test pressure may damage the boiler and the gas valve.

Max. test pressure 150 mbar.

Where higher pressure is required for tightness tests, separate the boiler and the gas valves from the gas supply pipe (undo the fitting).

3. Vent the gas line.



## Fitting the boiler and making connections (cont.)

### Connection, safety valve and condensate drain

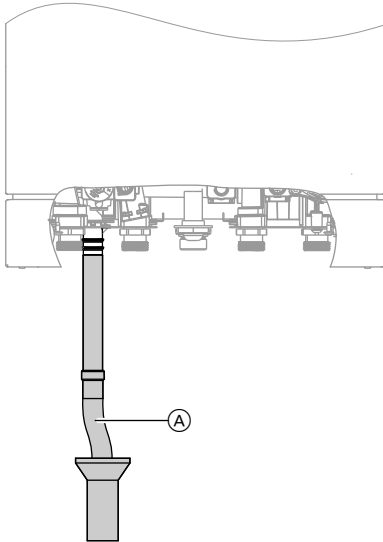

- The condensate line is connected with the safety valve discharge pipe. The condensate hose supplied meets the temperature requirements that are part of the CE certification.
- Connecting the condensate hose internally to the domestic waste water system, either directly or via a drip water funnel (tundish) is recommended.

- If the condensate line is routed outside the building, use a pipe of at least  $\varnothing$  30 mm and insulate it against frost. Avoid long external pipelines.



#### Please note

A frozen condensate pipe can result in faults and boiler damage. Always insulate condensate lines against frost.

- Observe the local building regulations. Connect condensate line (A) with a constant fall and a pipe vent to the public sewage system. Observe the local waste water regulations.

#### Note

*Fill the siphon with water before commissioning.*

## Fitting the boiler and making connections (cont.)

### Filling the siphon with water

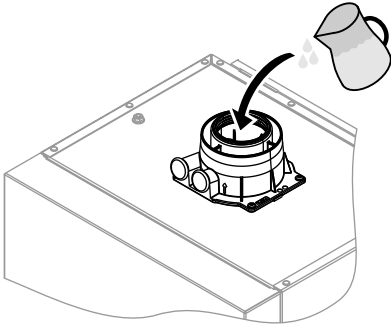

Fill a minimum of 0.3 l of water into the flue outlet.



#### **Please note**

At commissioning, flue gas may be emitted from the condensate drain.

Fill the siphon with water before commissioning.

### Balanced flue connection

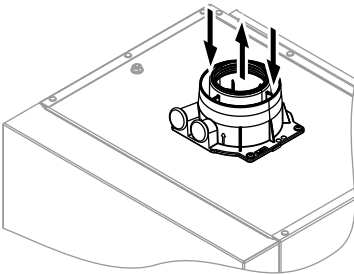

Connect the balanced flue.  
During installation and positioning of the flue system, observe Part L and BS 5440 building regulations.



Flue system installation instructions.

## Opening the control unit casing

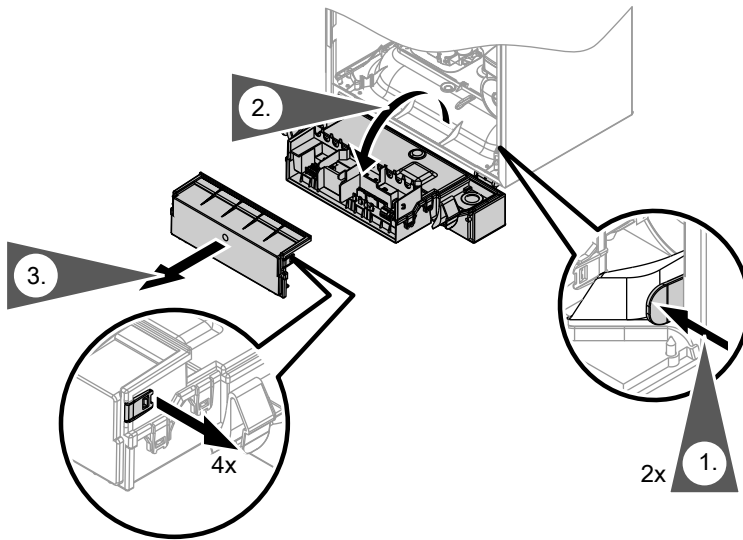

### Please note

Electronic assemblies can be damaged by electrostatic discharge.

Before beginning work, touch earthed objects, such as heating or water pipes, to discharge static loads.

## Electrical connections

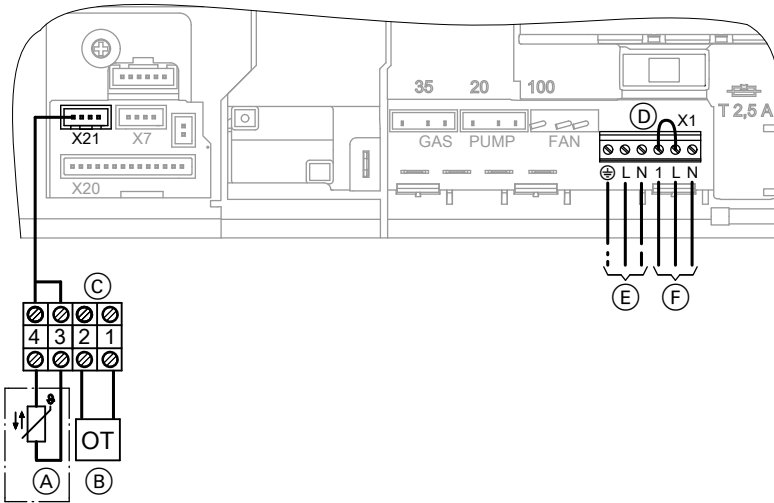

- (A) Only for weather-compensated mode:  
Outside temperature sensor (accessory)
- (B) OpenTherm device
- (C) Connecting cable (accessory)
- (D) Jumper
- (E) Power supply (230 V, 50 Hz).  
See page 17.
- (F) Vitotrol 100 or on-site room temperature controller (230 V switched input)  
Remove jumper (D) when making this connection.



### Information on connecting accessories

For this connection, observe the separate installation instructions provided with the accessories.



Separate installation instructions

## Electrical connections (cont.)

### Cable entry

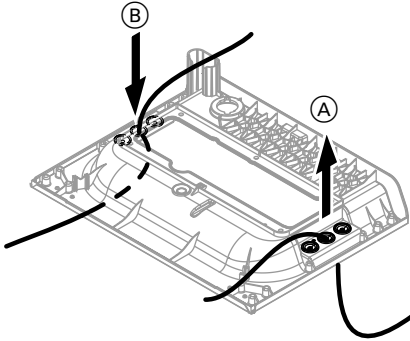

- (A) Power cable, remote control connecting cable
- (B) LV leads (sensor leads)

### Power supply

#### Regulations and Directives



#### Danger

Incorrect electrical installations can result in injuries from electrical current and in appliance damage.

Connect the power supply and implement all safety measures (e.g. RCD circuit) in accordance with the following regulations:

- IEC 60364-4-41
- VDE regulations [IEE or local regulations]
- Connection requirements specified by your local power supply utility

Install an isolator in the power supply line that simultaneously isolates all non-earthed conductors from the mains with at least 3 mm contact separation. We additionally recommend installing an AC/DC-sensitive RCD (RCD class B ) for DC (fault) currents that can occur with energy efficient equipment. Protect the power cable with an external 3 A fuse to BS 1362.



#### Danger

Incorrect core allocation can result in serious injury and damage to the appliance. Take care **not** to interchange wires "L1" and "N".

## Electrical connections (cont.)



### Danger

The absence of component earthing in the system can lead to serious injury from electrical current if an electrical fault occurs.

Connect the appliance and pipework to the equipotential bonding of the building in question.

## Routing connecting cables and closing the control unit



### Please note

Power cables will be damaged if they contact hot components. When routing and securing cables/leads on site, ensure that the maximum permissible temperatures for these cables/leads are not exceeded.

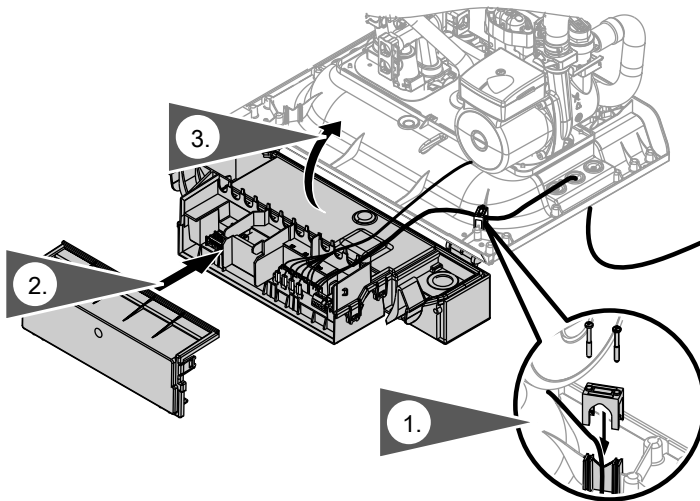

## Steps - commissioning, inspection and maintenance

For further information regarding the individual steps, see the page indicated

				Page
			Commissioning steps	
			Inspection steps	
			Maintenance steps	
•	•	•	<b>1. Filling the heating system.....</b>	20
•	•	•	<b>2. Venting the boiler by flushing.....</b>	22
•	•	•	<b>3. Changing to operation with LPG.....</b>	22
•			<b>4. Matching the burner output to the flue system.....</b>	23
•			<b>5. Adjusting the circulation pump to the heating system</b>	24
•	•	•	<b>6. Checking the static and supply pressure.....</b>	25
•			<b>7. Checking the CO<sub>2</sub> content.....</b>	27
	•	•	<b>8. Burner removal .....</b>	30
	•	•	<b>9. Checking the burner gasket and burner gauze assembly.....</b>	31
	•	•	<b>10. Checking and adjusting electrodes.....</b>	32
	•	•	<b>11. Cleaning the heat exchanger.....</b>	33
	•	•	<b>12. Checking the condensate drain and cleaning the siphon.....</b>	33
	•	•	<b>13. Burner installation .....</b>	34
	•	•	<b>14. Checking the diaphragm expansion vessel and system pressure.....</b>	35
•	•	•	<b>15. Checking all connections on the heating water side and DHW side for leaks</b>	
•	•	•	<b>16. Checking firm seating of electrical connections</b>	
•	•	•	<b>17. Checking gas equipment for tightness at operating pressure .....</b>	36
	•	•	<b>18. Fitting the front panel.....</b>	36
•			<b>19. Instructing the system user.....</b>	37

## Further details regarding the individual steps

### Filling the heating system



#### Please note

Unsuitable fill water increases the level of deposits and corrosion and may lead to boiler damage.

- Thoroughly flush the entire heating system prior to filling it.
- Only fill with water of potable quality.

- Soften fill water harder than 300 ppm.
- An antifreeze additive suitable for heating systems can be added to the fill water.

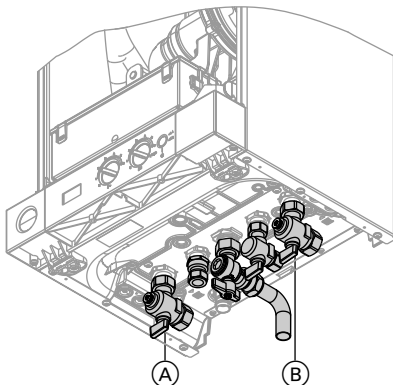
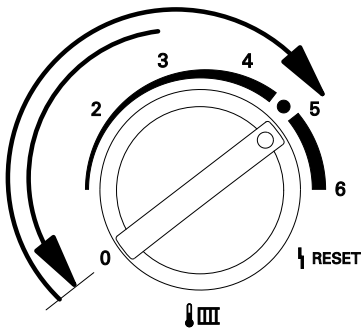

1. Close the gas shut-off valve.
2. Switch ON the power supply.
3. Turn rotary selector "III" fully anti-clockwise for less than 2 s and then clockwise back to the control range. The display shows "SERV", "III" and "🔌". The filling function has been activated. This function will end automatically after 20 min or after the ON/OFF switch has been turned off.
4. Open shut-off valves (A) and (B).



## Further details regarding the individual steps (cont.)

5. Fill heating system. (System pressure 0.8 to 1.2 bar).  
The system can be filled using a separate filling point fitted at a convenient position on the heating circuit. The connection must be removed when filling is completed. Where local Water Authority regulation does not allow temporary connection, a sealed system filler pump with break tank must be used. The heating system will not be filled automatically from the domestic hot water side. Alternative methods of filling sealed systems are given in BS 5449.

**Further details regarding the individual steps (cont.)**

**Venting the boiler by flushing**

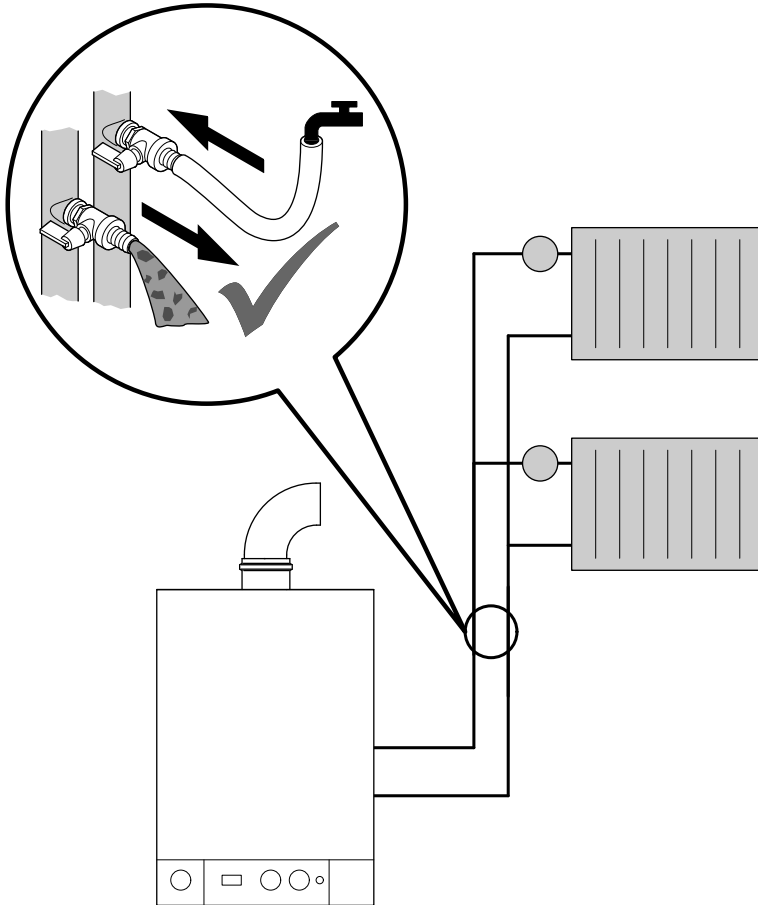

**Changing to operation with LPG**

In the delivered condition, the boiler is set up for operation with natural gas. For operation with LPG, change the gas nozzle and convert the gas type in the control unit.



Separate installation instructions.

Changing from LPG to natural gas - see page 51.

**Further details regarding the individual steps (cont.)**

**Matching the burner output to the flue system**

To match the burner output to the system's flue pipe length, a correction factor can be set.

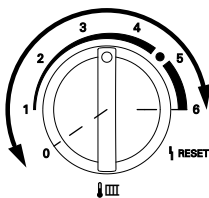
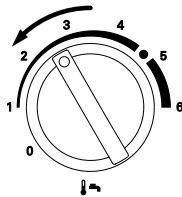
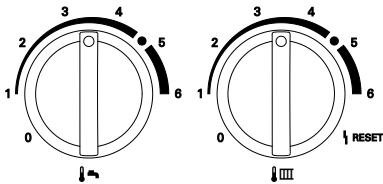

1. Turn ON/OFF switch on.
2. Turn both rotary selectors "🔥" and "🔧" simultaneously into their centre position.  
"SERV" appears on the display.
3. Refer to the following table for the correction factor required for the connected flue system.
4. Within 2 s, turn rotary selector "🔧" to the top left range.  
The display then shows "🔧", "🔥", "➡" and the selected correction factor begins to flash.  
In the delivered condition, factor 0 has been set.
5. Within 15 s, set rotary selector "🔧" to the required correction factor.
6. The set correction factor is saved when the value stops flashing, and the control unit returns to standard mode.

Correction factor		1	2	3	4	5	6
Flue system	Rated heating output (kW)	Max. run length (m)					
		Open flue operation $\varnothing$ 60 mm	21	4	10	16	22
	25	2	8	13.5	18.5	22	25

## Further details regarding the individual steps (cont.)

Correction factor		1	2	3	4	5	6
Balanced flue operation	21	2	6	10	13	16	19
Ø 60/100 mm coaxial	25	1	4	7	10	12	13.5

Observe max. flue lengths. A calculated performance verification is required if the max. flue lengths in the table are exceeded.

## Adjusting the circulation pump to the heating system

In the delivered condition, the circulation pump in heating mode is set to stage 1. If necessary to suit the heating system, the circulation pump can be changed over to stage 2.

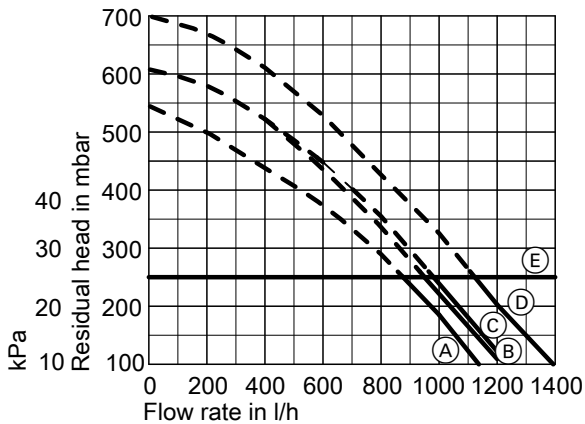

- (A) Gas condensing combi boiler 26 kW, pump stage 1
- (B) Gas condensing combi boiler 30 and 35 kW, pump stage 1
- (C) Gas condensing combi boiler 26 kW, pump stage 2
- (D) Gas condensing combi boiler 30 and 35 kW, pump stage 2
- (E) Upper operational limit

1. Turn ON/OFF switch on.

**Further details regarding the individual steps (cont.)**

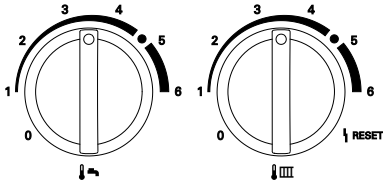

2. Turn both rotary selectors "🔥" and "🔧" simultaneously into their centre position.  
"SERV" appears on the display.

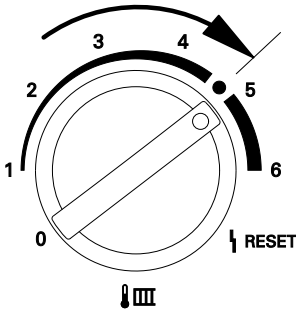

3. Within 2 s, turn rotary selector "🔧" to the top right range.  
"🔧" is displayed and the set value flashes.

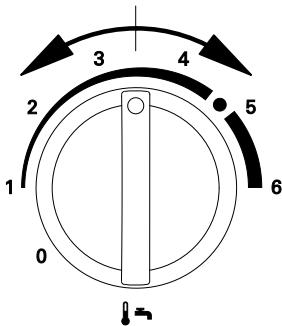

4. Adjust the control unit to stage 1 or 2 by turning rotary selector "🔧".  
The display shows:
  - "1" for operation with stage 1  
or
  - "2" for operation with stage 2.
5. The set operating mode is saved when the value stops flashing, and the control unit returns to standard mode.

**Checking the static and supply pressure**



**Danger**

CO build-up as a result of incorrect burner adjustment can have serious health implications. Carry out a CO test before and after work on gas appliances.

**Operation with LPG**

*Flush the LPG tank twice during commissioning or replacement. Vent the tank and gas supply line thoroughly after flushing.*

## Further details regarding the individual steps (cont.)

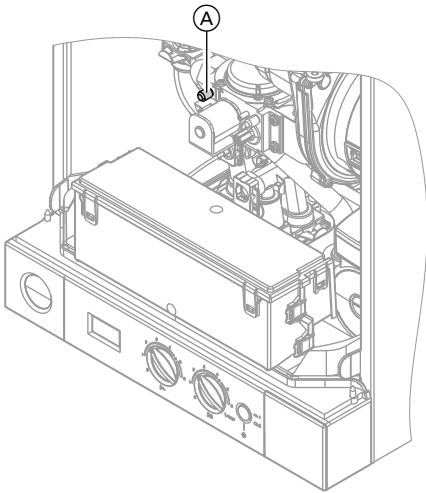

1. Close the gas shut-off valve.
2. Undo screw (A) inside test nipple "IN" on the gas train but do not remove it, and connect the pressure gauge.
3. Open the gas shut-off valve.
4. Check the static pressure.  
Set value: max. 57.5 mbar
5. Start the boiler.

### **Note**

*During commissioning, the boiler can enter a fault state because of airlocks in the gas line. After approx. 5 s press **RESET** to reset the burner.*

6. Check the supply (flow) pressure.

Set value:

- Natural gas: 20 mbar
- LPG: 37 mbar

### **Note**

*Use a suitable measuring device with a resolution of at least 0.1 mbar to check the supply pressure.*

7. Record the actual value in the report on page.  
Take the action shown in the following table.
8. Shut down the boiler, close the gas shut-off valve, remove the pressure gauge and close test nipple (A) with the screw.
9. Open the gas shut-off valve and start the appliance.



### **Danger**

Gas escaping from the test nipple leads to a risk of explosion.

Check gas tightness at test nipple (A).

## Further details regarding the individual steps (cont.)

Supply pressure (flow pressure)		Action
for natural gas	for LPG	
Below 17.4 mbar	Below 25 mbar	Do not start the boiler. Notify your gas supply utility or LPG supplier.
17.4 to 25 mbar	25 to 47 mbar	Start the boiler.
Above 25 mbar	Above 47 mbar	Install a separate gas pressure governor upstream of the system and regulate the pre-charge pressure to 20 mbar for natural gas or 37 mbar for LPG. Notify your gas supply utility or LPG supplier.

## Checking the CO<sub>2</sub> content

Vitodens 100-W is factory-set for natural gas. During commissioning or maintenance, the CO<sub>2</sub> and CO have to be measured at the boiler flue adaptor test point to check the flue integrity. Subject to the Wobbe index, the CO<sub>2</sub> content fluctuates between 7.4 % and 10.5 %. CO of up to 500 ppm is acceptable during start-up.

We recommend measuring O<sub>2</sub> as the value is unmistakable regarding lambda (air/gas). The O<sub>2</sub> content fluctuates between 7.5 % and 3.2 %. The CO/CO<sub>2</sub> ratio has to be less than 0.004.

If the actual CO<sub>2</sub> or O<sub>2</sub> and CO values deviate from the stated range, check the balanced flue systems for leaks. If flue installation is o.k., change the gas valve.

### Note

*Operate the appliance with uncontaminated combustion air to prevent operating faults and damage.*

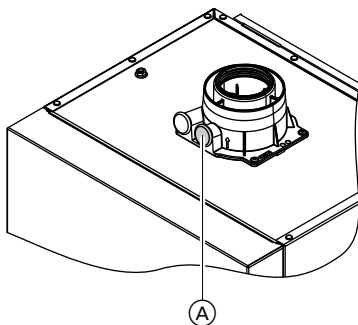

1. Connect a flue gas analyser to flue gas port (A) on the boiler flue connection.
2. Start the boiler and check for leaks.



### Danger

Escaping gas leads to a risk of explosion.

Check gas equipment for tightness.



## Further details regarding the individual steps (cont.)

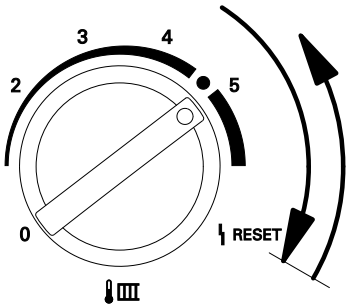

3. Turn rotary selector "🌡️ IIII" fully clockwise for less than 2 s and then back to the control range on the right. The display shows "SERV", "👁️" and the boiler water temperature is shown.

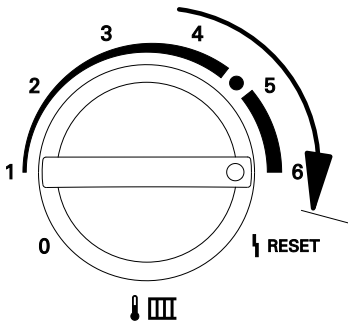

4. Adjust the upper heating output: Turn rotary selector "🌡️ IIII" to the control range on the right until the display shows 5 bars for the upper heating output.

5. Measure the CO<sub>2</sub> content for upper heating output. The CO<sub>2</sub> content must be between 7.0 and 10.5 %.

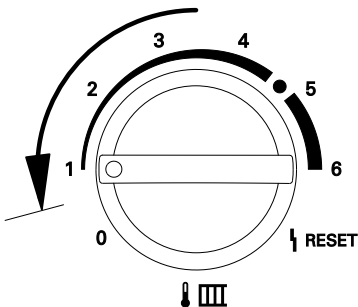

6. Adjust the lower heating output: Turn rotary selector "🌡️ IIII" to the control range on the left until the display shows 1 bar for the lower heating output.
7. Test the CO<sub>2</sub> content for lower heating output. The CO<sub>2</sub> content must be between 0.3 and 0.9 % below the value for the upper heating output.



**Further details regarding the individual steps (cont.)**

8. ■ If the CO<sub>2</sub> content is within the given range, continue with point 10.
  - If the CO<sub>2</sub> content is **outside** the given range, check the flue gas/ventilation air system for tightness; remove any leaks. Replace gas train if required.
9. Test the CO<sub>2</sub> content for upper and lower heating output again.
10. Shut the boiler down, remove flue gas analyser and close flue gas port (A).
11. Turn both rotary selectors "🔧" and "🔧" simultaneously into their original positions.

## Further details regarding the individual steps (cont.)

### Burner removal

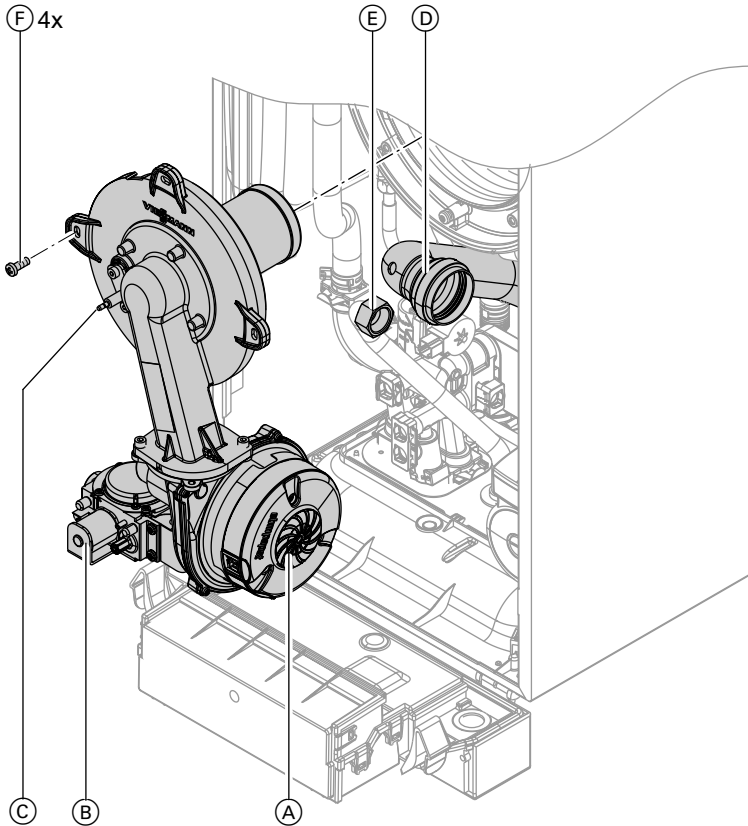

1. Switch off the power.
2. Shut off the gas supply.
3. Pull power cables from fan motor (A), gas valve (B) and electrodes (C).
4. Pull the venturi extension (D) from the fan.
5. Undo gas supply pipe fitting (E).
6. Undo four screws (F) and remove the burner.



#### Please note

Prevent damage.  
Never rest the burner on the burner gauze assembly.

## Further details regarding the individual steps (cont.)

### Checking the burner gasket and burner gauze assembly

Check burner gasket (A) for damage and replace if required.

Replace the burner gauze assembly if it is damaged.

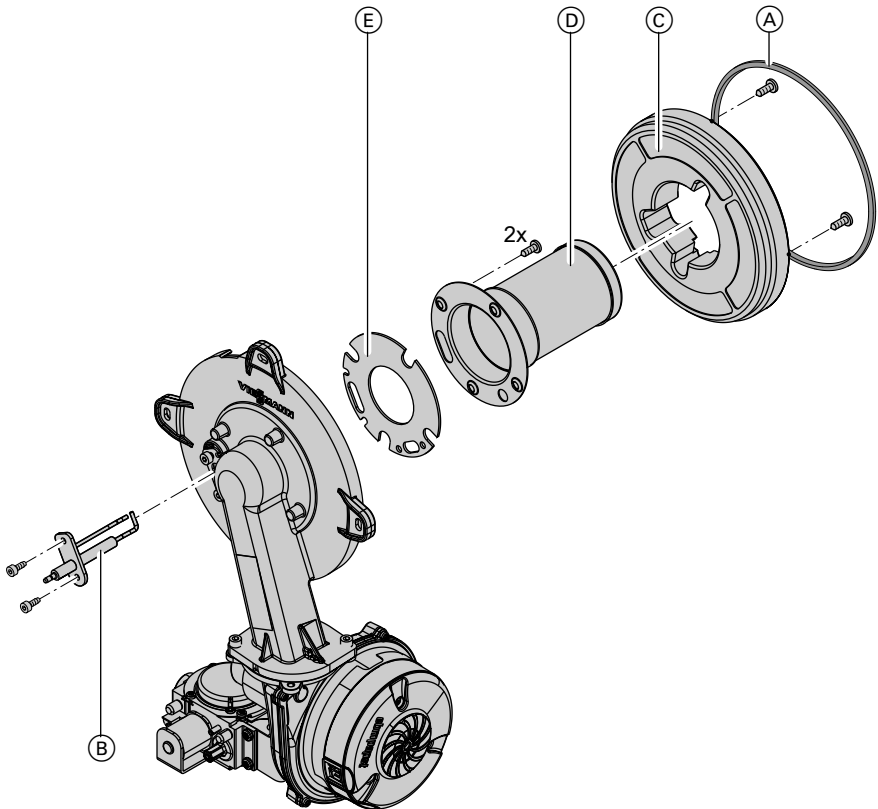

1. Remove electrode (B).
2. Undo two Torx screws and remove thermal insulating ring (C).
3. Undo two Torx screws and remove burner gauze assembly (D) with its gasket (E).
4. Insert a new gasket (E) into the new burner gauze assembly (D) and secure.



#### Please note

Tighten screws far enough to prevent damage to components and to ensure the function is guaranteed.

## Further details regarding the individual steps (cont.)

### 5. Fit thermal insulation ring (C).



**Please note**

Tighten screws far enough to prevent damage to components and to ensure the function is guaranteed.

### 6. Fit electrode (B).



**Please note**

Tighten screws far enough to prevent damage to components and to ensure the function is guaranteed.

## Checking and adjusting electrodes

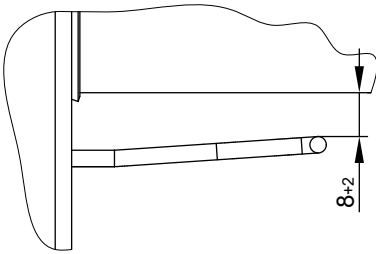

2. Clean the electrode with a small brush (not with a wire brush) or sandpaper.

3. Check the electrode gaps. If the gaps are not as specified or the electrode is damaged, replace and align the electrode together with a new gasket. Tighten electrode fixing screws.

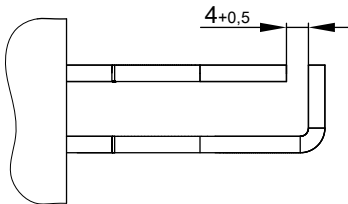

1. Check the electrode for wear and contamination.



**Please note**

Tighten screws far enough to prevent damage to components and to ensure the function is guaranteed.

## Further details regarding the individual steps (cont.)

### Cleaning the heat exchanger

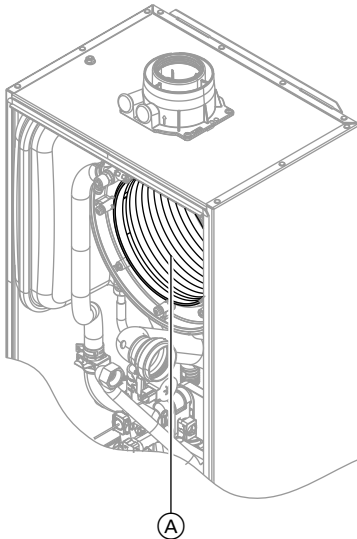

- !** **Please note**  
Scratches on parts that are in contact with flue gas can lead to corrosion.  
**Never use brushes to clean the heat exchanger.**

Use a vacuum cleaner to remove residues from heat exchanger (A) inside the combustion chamber.

- If required, spray slightly acidic, chloride-free cleaning agents based on phosphoric acid onto heat exchanger (A) and let the solution soak in for at least 20 min.
- Thoroughly flush heat exchanger (A) with water.

### Checking the condensate drain and cleaning the siphon

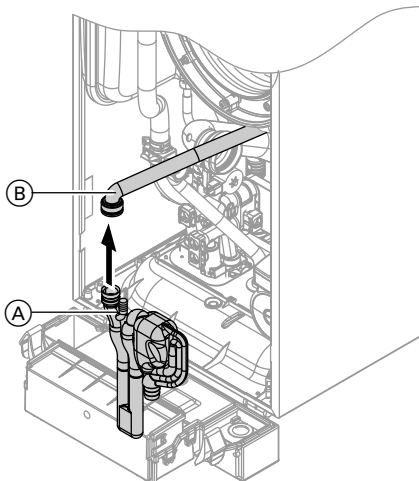

- Pull siphon (A) upwards out of the drain connection.
- Detach supply hose (B) from siphon (A).
- Clean siphon (A).
- Reconnect supply hose (B).
- Refit siphon (A) to the drain connection.
- Fill siphon (A) with water by pouring about 0.3 l of water into the combustion chamber.





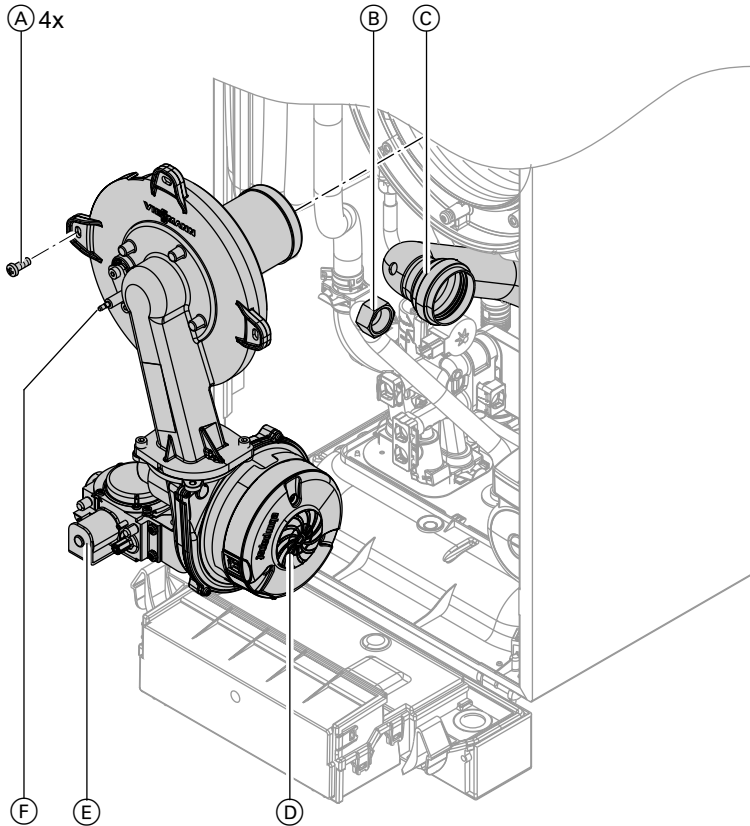

**Further details regarding the individual steps (cont.)**

7. Check that condensate can drain freely and that the connections are tight.

**Burner installation**



## Further details regarding the individual steps (cont.)

1. Fit the burner and tighten four screws  across.
2. Insert new gasket and tighten the fittings on gas supply pipe .
3. Plug the venturi extension  into the fan.
4. Fit electrical cables to fan motor , gas valve  and ignition unit .
5. Reopen gas supply and switch on power supply.
6. Check the gas connections for tightness.



### Please note

Tighten screws far enough to prevent damage to components and to ensure the function is guaranteed.



### Danger

Escaping gas leads to a risk of explosion.  
Check all fittings for gas tightness.



### Please note

The use of leak detection spray can result in incorrect functions.  
Leak detection spray must not reach electrical contacts or seal diaphragm openings on the gas valve.

## Checking the diaphragm expansion vessel and system pressure

### Note

*The diaphragm expansion vessel can lose some charge pressure over a time in use. When the boiler heats up, the pressure gauge will indicate a higher pressure of 2 or 3 bar. The safety valve too can respond and discharge excess pressure.*

Check whether the installed diaphragm expansion vessel is adequate for the system water volume.  
Carry out this test on a cold system.

1. Drain the system or close the cap valve on the diaphragm expansion vessel and reduce the pressure until the pressure gauge indicates "0".
2. If the pre-charge pressure of the diaphragm expansion vessel is lower than the static system pressure, top up with nitrogen until the pre-charge pressure is raised by 0.1 to 0.2 bar.
3. Top up with water until the charge pressure of the cooled system is at least 1.0 bar and 0.1 to 0.2 bar higher than the pre-charge pressure of the diaphragm expansion vessel.  
Permiss. operating pressure: 3 bar

## Further details regarding the individual steps (cont.)

### Checking gas equipment for tightness at operating pressure



**Danger**

Escaping gas leads to a risk of explosion.  
Check gas equipment for tightness.



**Please note**

The use of leak detection spray can result in incorrect functions. Leak detection spray must not reach electrical contacts or seal diaphragm openings on the gas valve.

### Fitting the front panel

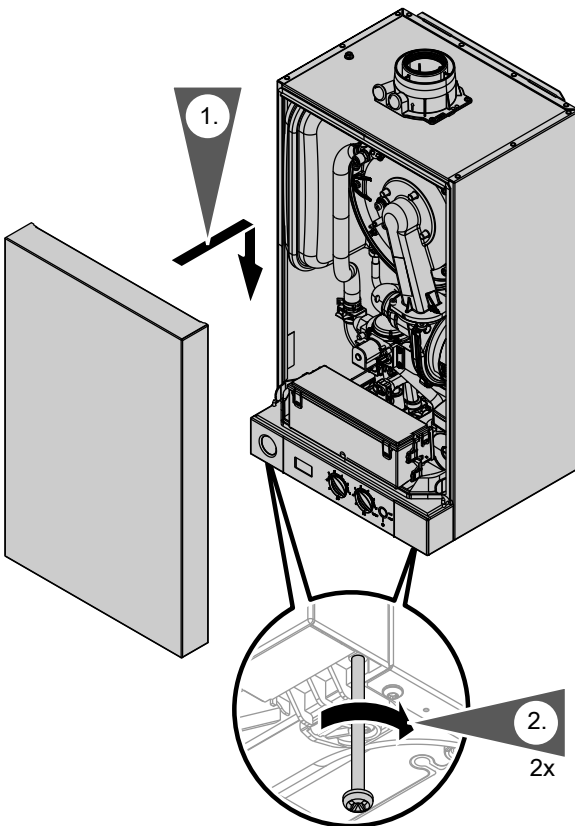

1. Hook the front panel into place.

2. Tighten screws at the bottom.



## Further details regarding the individual steps (cont.)

### Instructing the system user

The system installer must hand the operating instructions to the system user and instruct the user in the operation of the system.

## Function sequence and possible faults

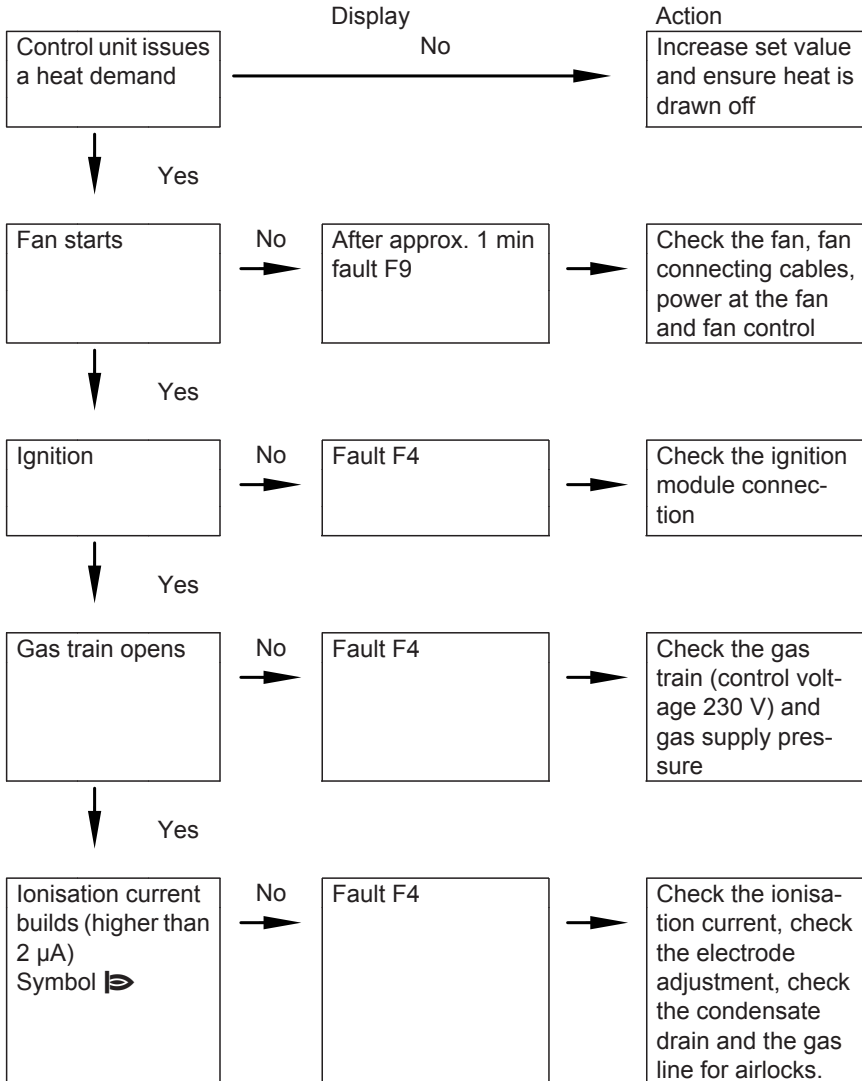

**Function sequence and possible faults (cont.)**

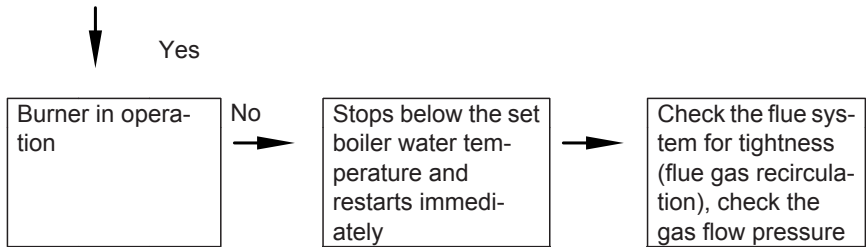

**Fault messages on the display**



Faults are indicated by a flashing fault code with fault symbol "F" on the display. For fault code explanations see the following table.

Displayed fault code	System characteristics	Cause	Measures
30	Burner blocked	Short circuit, boiler water temperature sensor	Check the boiler water temperature sensor (see page 44).
38	Burner blocked	Lead break, boiler water temperature sensor	Check the boiler water temperature sensor (see page 44).
51	No DHW heating	Short circuit, outlet temperature sensor	Check the sensor (see page 46).
52	Burner blocked	Short circuit, flow sensor	Check connections and lead; replace sensor if required.
59	No DHW heating	Lead break, outlet temperature sensor	Check the sensor (see page 46).
5A	Burner blocked	Lead break, flow sensor	Check connections and lead; replace sensor if required.

**Fault messages on the display** (cont.)

<b>Displayed fault code</b>	<b>System characteristics</b>	<b>Cause</b>	<b>Measures</b>
b0	Burner blocked	Short circuit, flue gas temperature sensor	Check the sensor (see page 47).
b8	Burner blocked	Lead break, flue gas temperature sensor	Check the sensor (see page 47).
E3	Burner in a fault state	Fault in safety chain.	Check the temperature limiter and connecting leads (see page 45). Check the control unit, and replace if required.
E5	Burner blocked	Internal fault	Check the ionisation electrode and connecting cables. Press "Reset" (see page 42).
F0	Burner blocked	Internal fault	Replace control unit.
F1	Burner in a fault state	Max. flue gas temperature exceeded	Check heating system fill level. Check circulation pump. Vent the system. Press "Reset" (see page 42).
F2	Burner in a fault state	The temperature limiter has responded	Check heating system fill level. Check circulation pump. Vent the system. Check the temperature limiter and connecting leads (see page 45). Press "Reset" (see page 42).
F3	Burner in a fault state	Flame signal is already present at burner start	Check ionisation electrode and connecting cable. Press "Reset" (see page 42).

**Fault messages on the display (cont.)**

<b>Displayed fault code</b>	<b>System characteristics</b>	<b>Cause</b>	<b>Measures</b>
F4	Burner in a fault state	No flame signal detected	Check the ionisation electrode and cables, check the gas pressure, check the gas train, ignition, ignition module and condensate drain. Press "Reset" (see page 42).
F8	Burner in a fault state	Fuel valve closes too late	Check gas train. Check both control paths. Press "Reset" (see page 42).
F9	Burner in a fault state	Fan speed too low during burner start	Check fan, fan connecting cables and power supply; check fan control. Press "Reset" (see page 42).
FA	Burner in a fault state	Fan not at standstill	Check fan, fan connecting cables and fan control. Press "Reset" (see page 42).
FC	Burner blocked	Electrical fan control (control unit) faulty	Check fan connecting cable; if required, replace or replace control unit



**Fault messages on the display (cont.)**

Displayed fault code	System characteristics	Cause	Measures
Fd	Burner blocked	Fault, burner control unit	<p>Check ignition electrodes and connecting cables. Check whether a strong interference (EMC) field exists near the appliance.</p> <p>Press "Reset" (see page 42). Replace control unit if fault persists.</p>
FF	Burner blocked	Fault, burner control unit	<p>Check ignition electrodes and connecting cables. Check whether a strong interference (EMC) field exists near the appliance.</p> <p>Press "Reset" (see page 42). Replace control unit if fault persists.</p>

**Press reset**

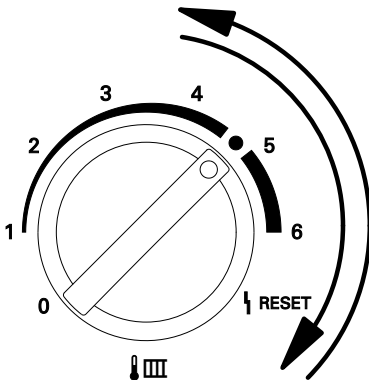

Turn rotary selector "🔥" less than 2 s to "⏏️RESET", then back to the control range.

Repairs

Removing the front panel

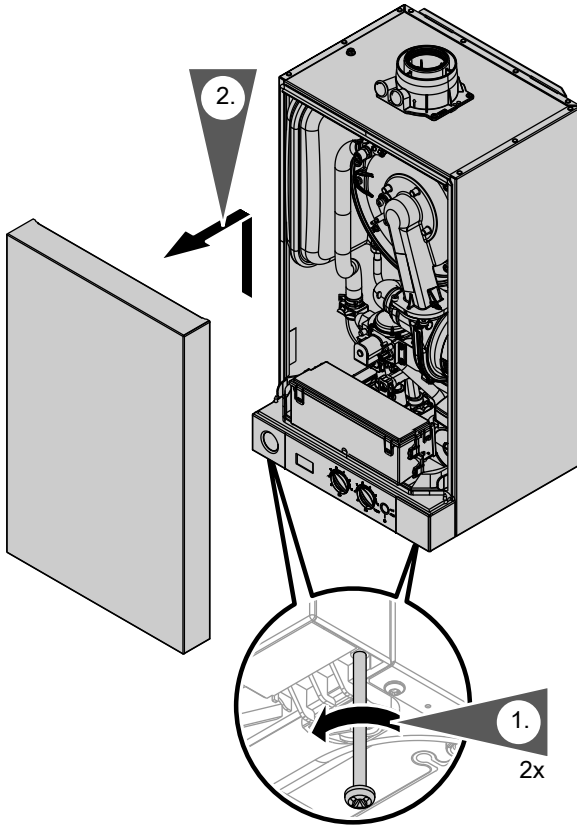

1. Release screws at the bottom of the boiler; do not remove completely.
2. Remove front panel.

## Repairs (cont.)

### Boiler water temperature sensor

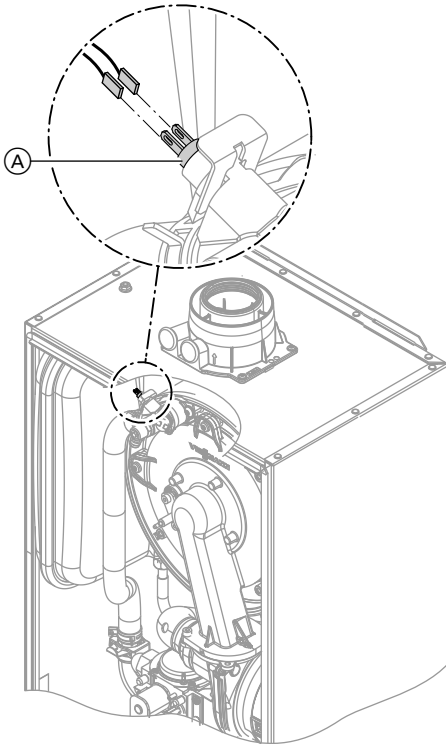

1. Pull the leads off boiler water temperature sensor (A) and check the resistance.



## Repairs (cont.)

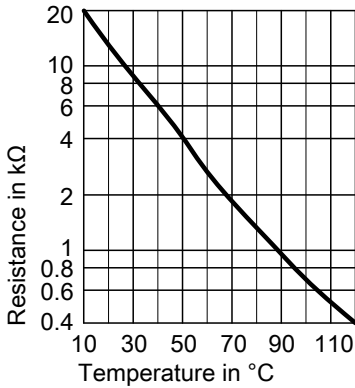

2. Check the sensor resistance and compare it with the curve.
3. In the case of severe deviation, drain boiler on the heating water side and replace the sensor.



### Danger

The boiler water temperature sensor is immersed in the heating water (risk of scalding).

Drain the boiler before replacing the sensor.

## Checking the temperature limiter

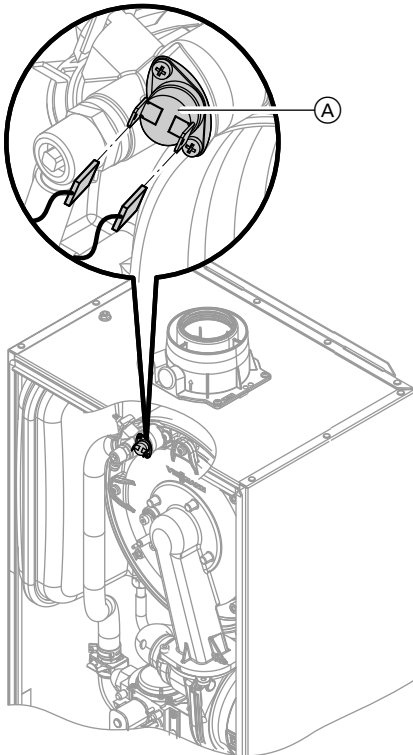

If the burner control unit cannot be reset after a fault shutdown, although the boiler water temperature is below approx. 95 °C, check the temperature limiter.

1. Pull the leads from temperature limiter (A).
2. Check the continuity of the temperature limiter with a multimeter.
3. Remove the faulty temperature limiter.
4. Install a new temperature limiter.
5. Press "Reset" at the control unit (see page 42).

## Repairs (cont.)

### Checking the outlet temperature sensor

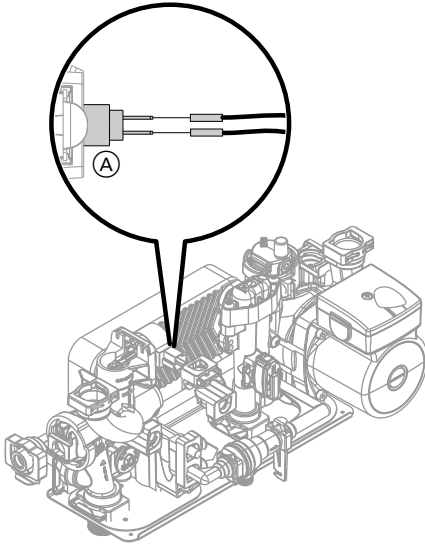

1. Pull the leads from outlet temperature sensor (A) .
2. Check the sensor resistance and compare it with the curve.

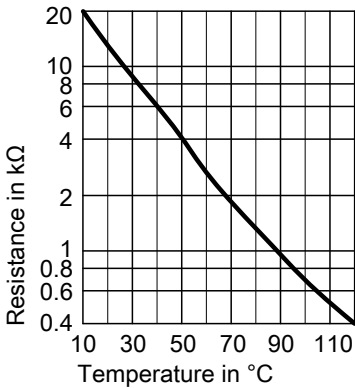

3. Replace the sensor in the case of severe deviation.

**Note**

*Water can leak when replacing the outlet temperature sensor. Shut off the cold water supply. Drain the DHW line and the plate heat exchanger (DHW side).*

## Repairs (cont.)

### Check flue gas temperature sensor

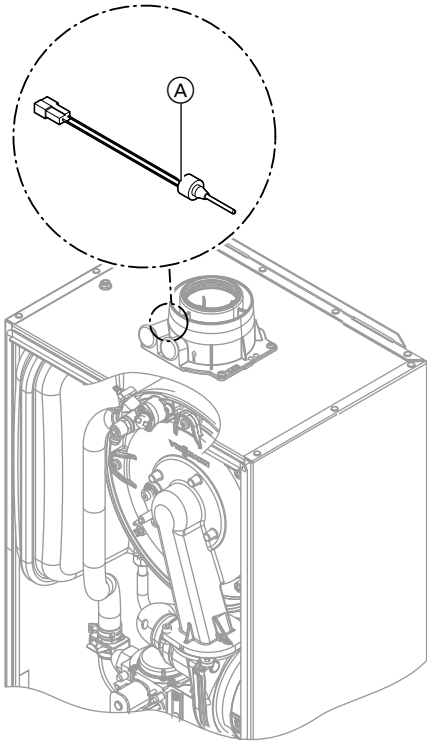

1. Pull leads from flue gas temperature sensor (A) .
2. Check the sensor resistance and compare it with the curve.

## Repairs (cont.)

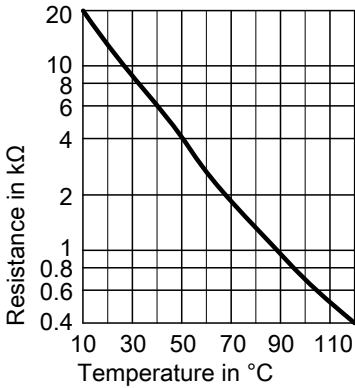

3. Replace the sensor in the case of severe deviation.

## Replacing flow limiter

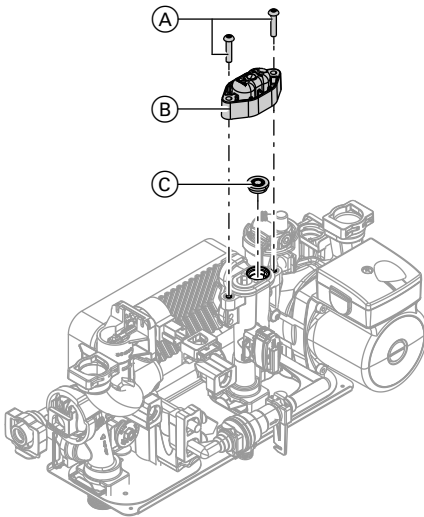

1. Drain the boiler from the DHW side.
2. Pivot the control unit downwards.
3. Undo screws (A).
4. Remove cap (B).
5. Remove faulty flow limiter (C).
6. Select a new flow limiter (C) from the following table.

Flow rate l/min	Colour
12	Red

7. Insert new flow limiter (C).
8. Fit new cap (B) supplied.

Repairs (cont.)

Checking or replacing the plate heat exchanger

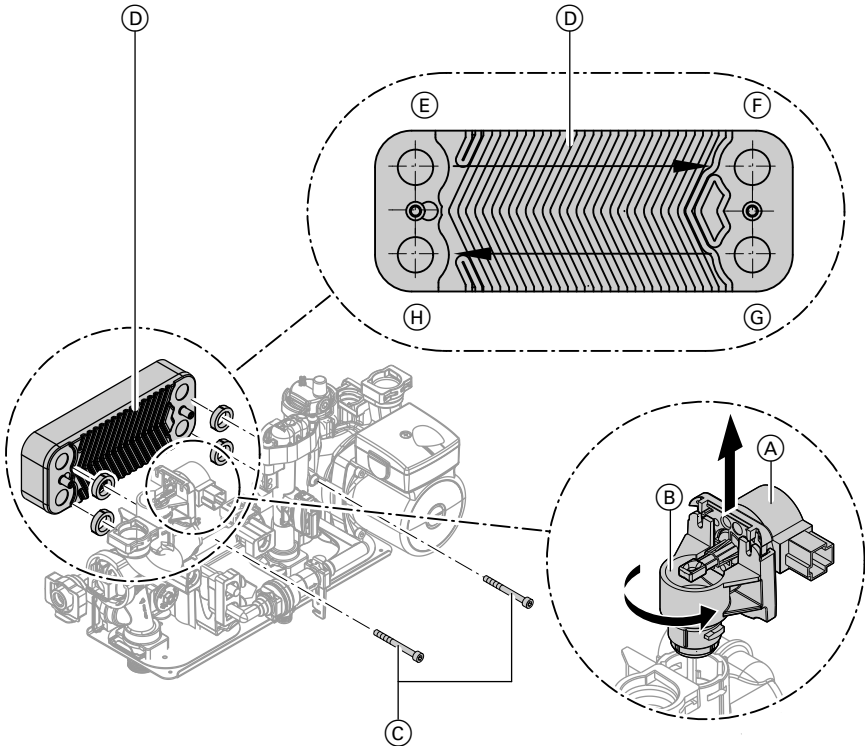

- (E) Heating water flow
- (F) Heating water return

- (G) Cold water
- (H) DHW

1. Shut off and drain the boiler on the heating water and the DHW side.
2. Flip down control unit.
3. Push servomotor (A) slightly upwards.
4. Turn adaptor (B) with servomotor (A) 1/8 of a turn anticlockwise and remove.
5. Remove two screws (C) from the plate heat exchanger and remove plate heat exchanger (D) with gas-kets.

**Note**

*During removal, small amounts of water may trickle out and escape from the plate heat exchanger.*

## Repairs (cont.)

6. Check the DHW side for scaling and if required clean or replace the plate heat exchanger.
7. Check the heating water side for contamination and if required clean or replace the plate heat exchanger.
8. Install in reverse order with new gaskets.

### Note

*During installation, ensure that fixing holes are aligned and gaskets seated correctly. Install the plate heat exchanger with the correct orientation.*

## Checking the fuse

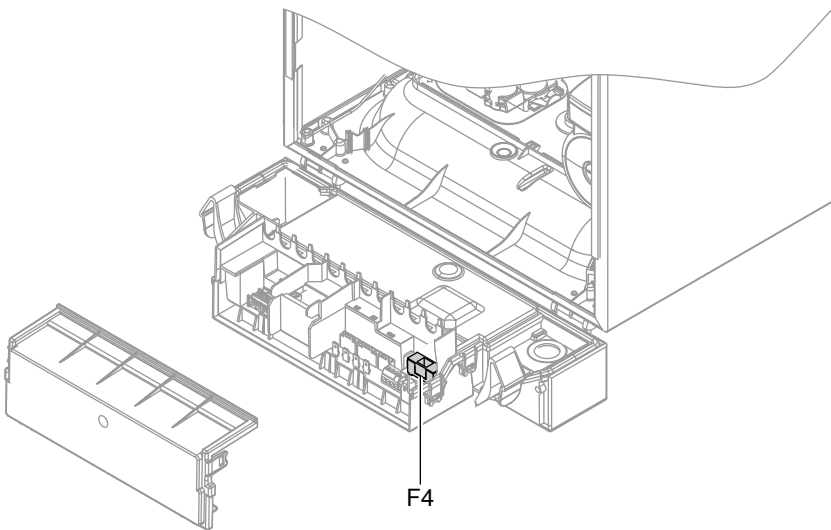

1. Switch off the power.
2. Open control unit casing (see page 15).
3. Check fuse F4.

## Converting from LPG to natural gas

### Removing gas restrictor

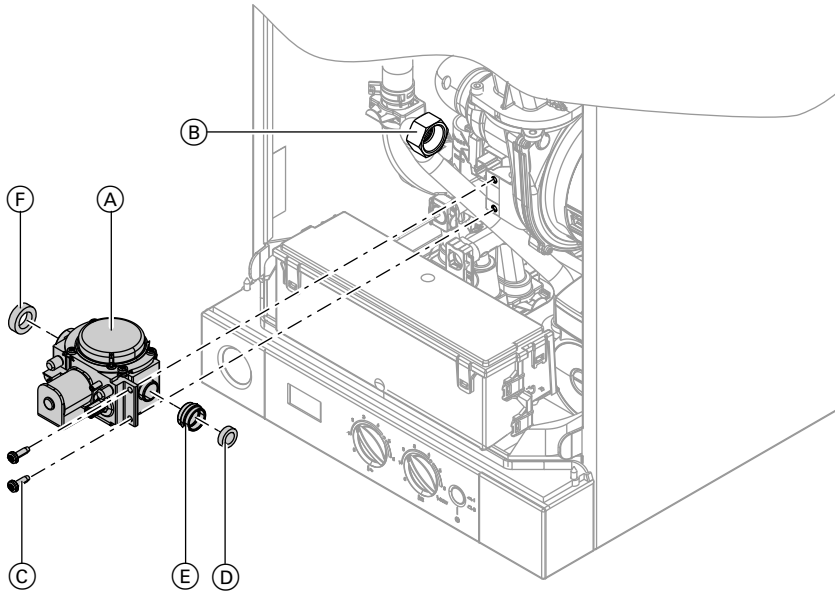

1. Pull power cable from gas train (A).
2. Undo union nut (B).
3. Undo two screws (C) and remove gas train (A).
4. Remove gas restrictor (D) from gas train (A).
5. Fit gas train (A) with new gaskets (E) and (F).
6. Remove or void gas type sticker on the top of the boiler (next to the type plate).
7. Start the boiler and check for leaks.



#### Danger

Escaping gas leads to a risk of explosion.  
Check gas equipment for tightness.



#### Please note

Tighten screws far enough to prevent damage to components and to ensure the function is guaranteed.

## Converting from LPG to natural gas (cont.)

### Changing the gas type at the control unit

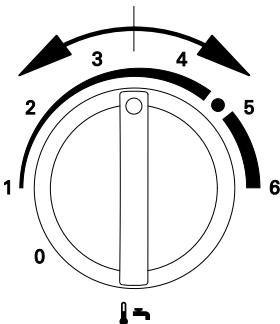
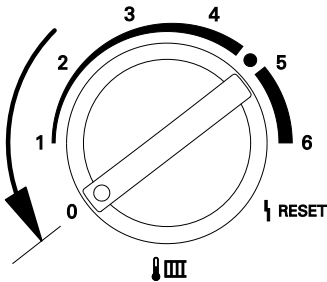
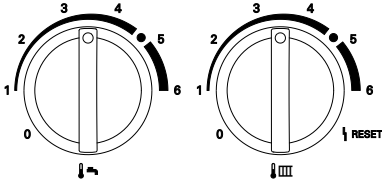

1. Turn ON/OFF switch on.
2. Turn both rotary selectors "🔥🔌" and "🔥📊" simultaneously into their centre position.  
"SERV" appears on the display.
3. Turn rotary selector "🔥📊" fully anti-clockwise within 2 s.  
"👁️" and the new selected value flash on the display.
4. Adjust the control unit to natural gas or LPG by turning the rotary selector "🔥🔌".  
The display shows:
  - "0" for operation with natural gas  
or
  - "1" for operation with LPG.
5. The set operating mode is saved when the value stops flashing, and the control unit returns to standard mode.

### Checking the CO<sub>2</sub> content

See page.



## Connection and wiring diagram

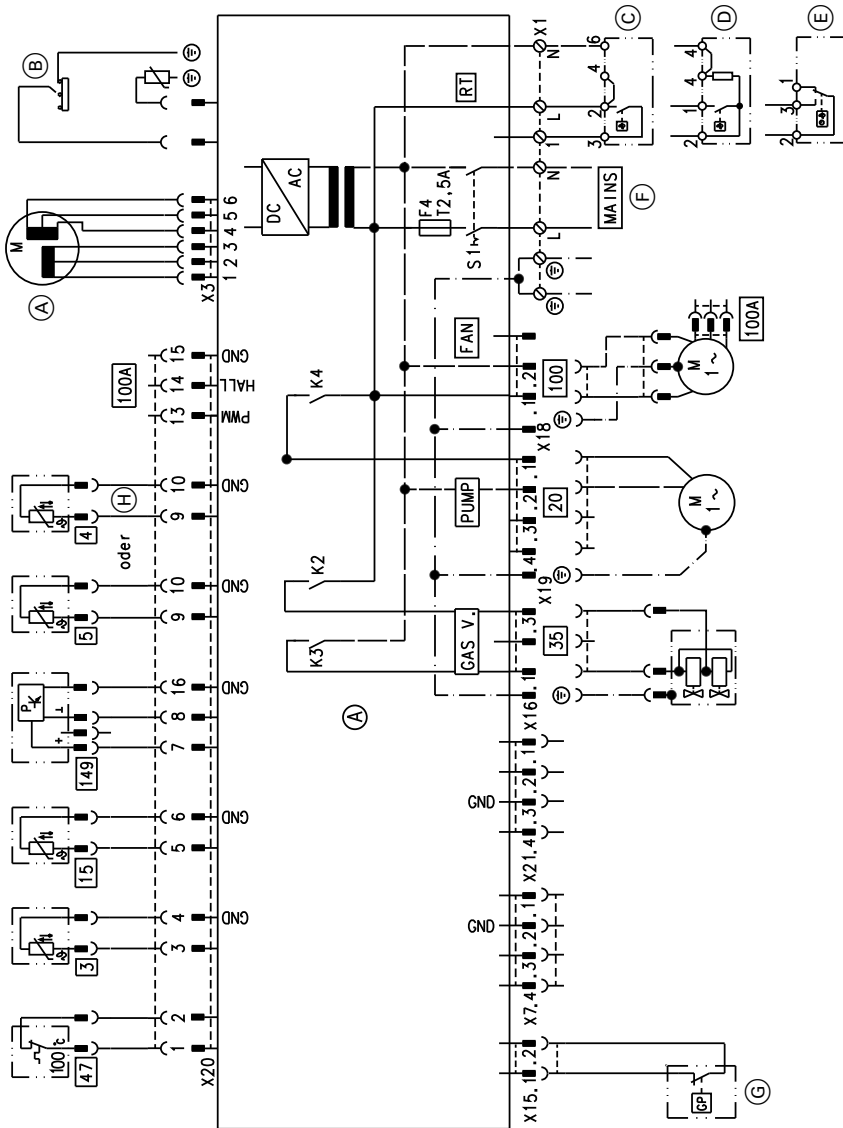

(A) Stepper motor diverter valve  
 (B) Ignition/ionisation

(C) Vitotrol 100, type UTA or on-site room temperature controller (switched 230 V input)

**Connection and wiring diagram (cont.)**

<p>Ⓓ Vitotrol 100, type RT or on-site room temperature controller (switched 230 V input)</p> <p>Ⓔ Vitotrol 100, type UTDB or on-site room temperature controller (switched 230 V input)</p> <p>Ⓕ Power input 230 V/50 Hz</p> <p>Ⓖ Gas pressure switch (Open-Therm appliance)</p> <p>Ⓗ PCB inside the control unit</p> <p>X ... Electrical interface</p>	<p>3</p> <p>4</p> <p>5</p> <p>15</p> <p>20</p> <p>35</p> <p>47</p> <p>100</p> <p>100A</p> <p>149</p>	<p>Boiler water temperature sensor</p> <p>Outlet temperature sensor</p> <p>No function</p> <p>Flue gas temperature sensor</p> <p>Circulation pump 230 V~</p> <p>Gas solenoid valve</p> <p>Temperature limiter</p> <p>Fan motor 230 V~</p> <p>Fan control</p> <p>Flow sensor</p>
---	--	---

## Ordering parts

**The following information is required:**

- Serial no. (see type plate (A))
- Assembly (from this parts list)
- Position number of the individual part within the assembly (from this parts list)

Standard parts are available from your local supplier.

## Overview of the assemblies

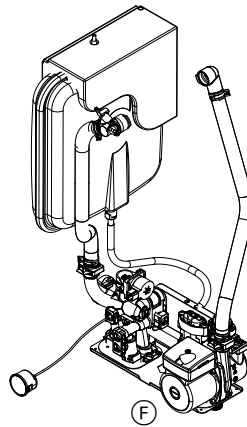
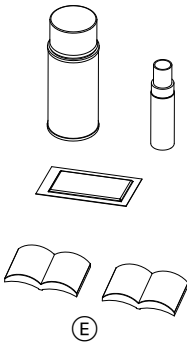
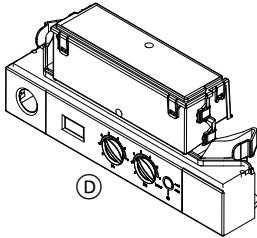
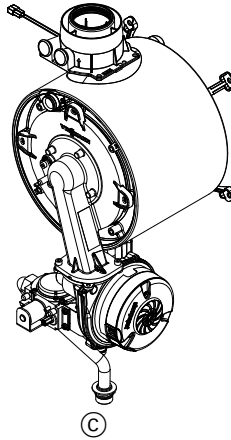
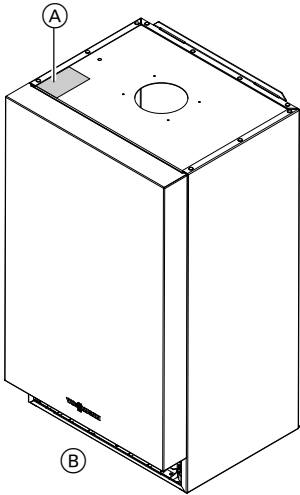

- (A) Type plate
- (B) Sheet metal parts assembly
- (C) Heat cell assembly

- (D) Control unit assembly
- (E) Miscellaneous assembly
- (F) Hydraulic assembly

## Sheet metal parts assembly

- |      |                          |      |                          |
|------|--------------------------|------|--------------------------|
| 0001 | Front panel              | 0005 | Air box floor            |
| 0002 | Profiled seal            | 0006 | Diaphragm grommets (set) |
| 0003 | Logo                     | 0007 | Wall mounting bracket    |
| 0004 | Strain relief upper part |      |                          |

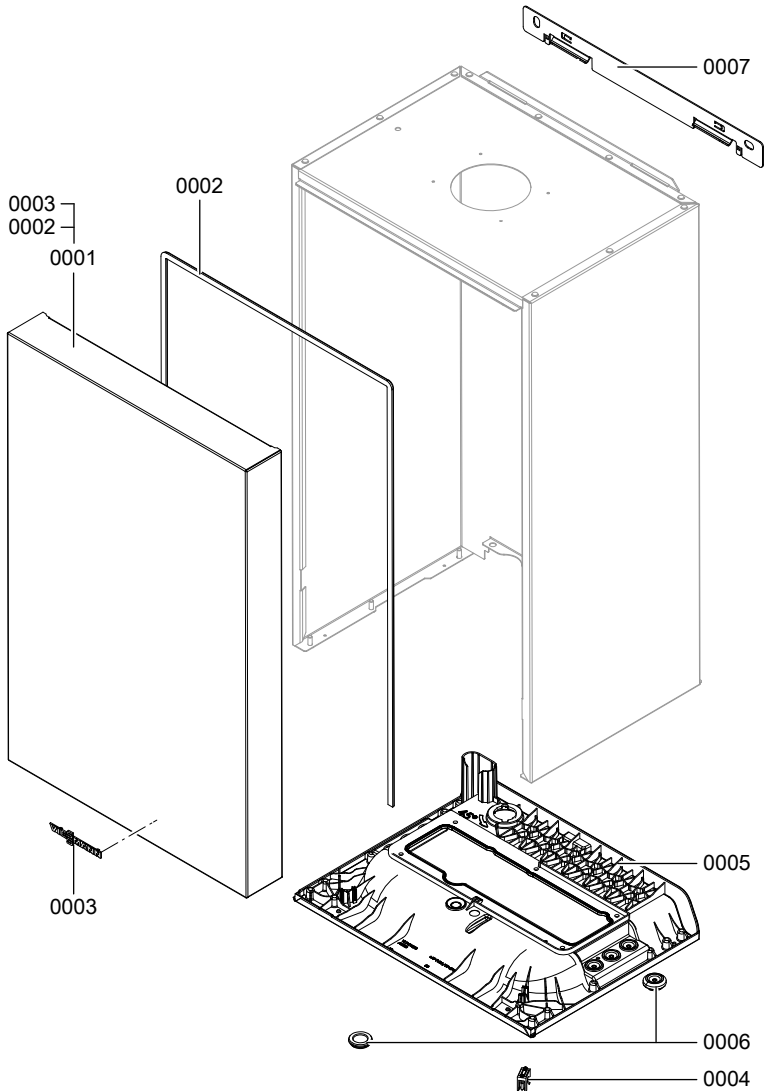

## Heat cell assembly

- |      |                             |      |                               |
|------|-----------------------------|------|-------------------------------|
| 0001 | Gasket DN 60                | 0009 | Tee                           |
| 0002 | Boiler flue connection      | 0010 | Gas pipe                      |
| 0003 | Boiler flue connection plug | 0011 | Gasket 17 x 24 x 2 (set)      |
| 0004 | Flue gas gasket             | 0012 | Burner                        |
| 0005 | Flue gas temperature sensor | 0013 | Thermal insulation block      |
| 0006 | Heat exchanger              | 0014 | Heat exchanger mounting (set) |
| 0007 | Condensate hose             | 0015 | O-ring gasket set 20.6 x 2.6  |
| 0008 | Siphon                      | 0016 | Condensate hose 400 mm long   |

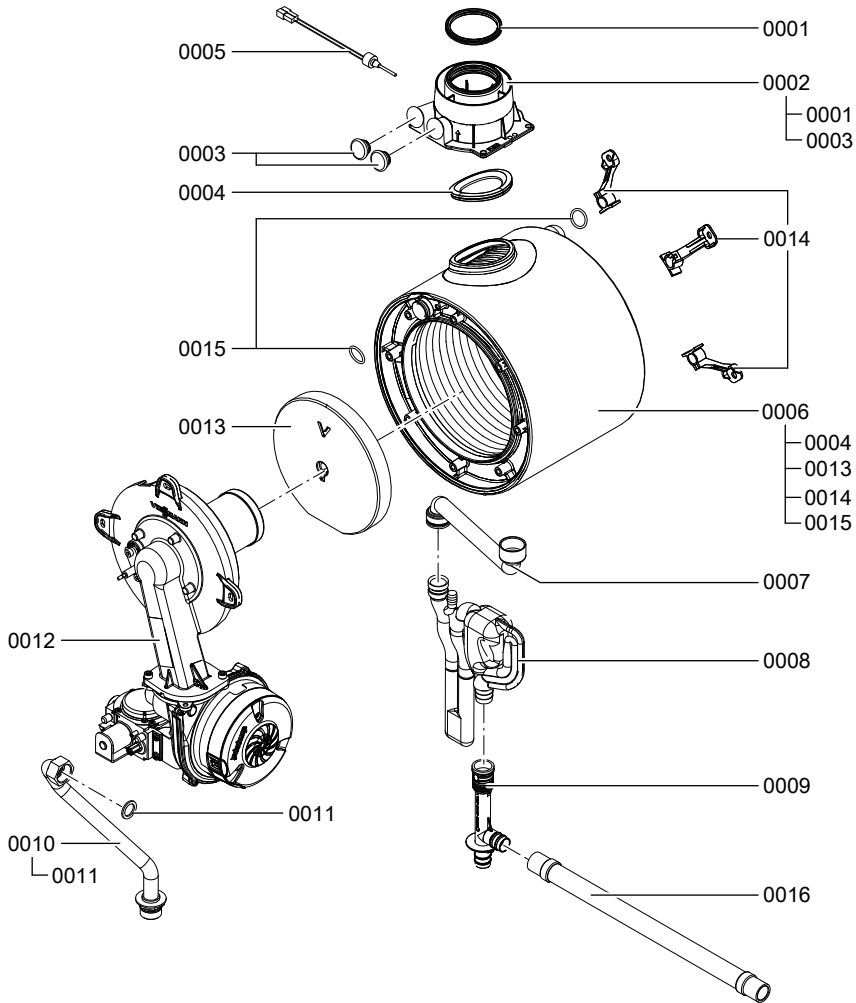

**Burner assembly**

0001	Burner gasket	0008	Burner door flange gasket
0002	Thermal insulation ring	0009	Radial fan
0003	Cylinder burner gauze assembly	0010	Gas valve
0004	Burner gauze assembly gasket	0012	Venturi extension
0005	Burner door	0013	Gasket set
0006	Ionisation electrode gasket	0014	Conversion kit G2.350/G27
0007	Ignition and ionisation electrode		

**Burner assembly (cont.)**

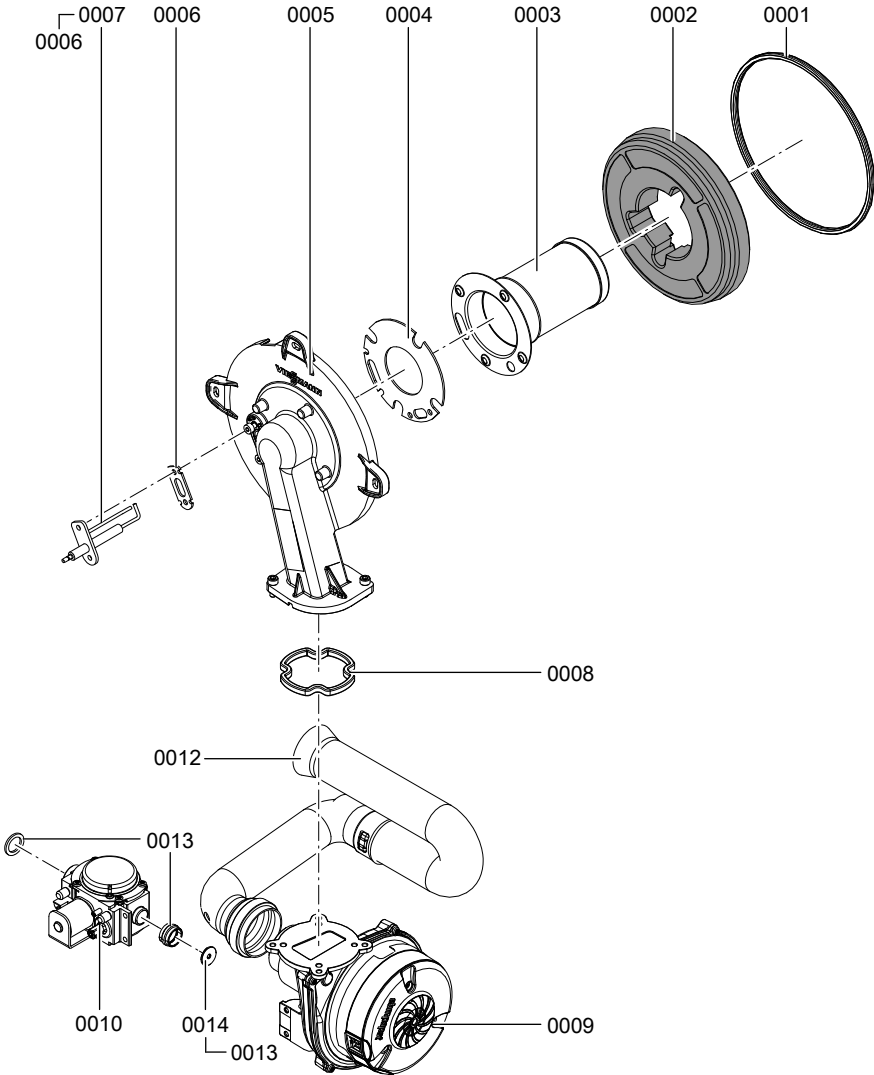



## Hydraulic assembly

0001	Diaphragm expansion vessel	0010	O-ring gasket set 20.6 x 2.6
0002	Support block, diaphragm expansion vessel	0011	Temperature sensor
0003	Gasket A 10 x 15 x 1.5 (set)	0012	Round sealing ring 8 x 2 (5 pce)
0004	Connection line; diaphragm expansion vessel	0013	Moulded hose heating water flow
0005	Heating water return connection elbow	0014	Clip Ø 18 (5 pce)
0006	Moulded hose heating water return	0015	O-ring 17 x 4 (5 pce)
0007	Hose clip DN 25	0016	Pressure gauge
0008	Clip Ø 10 (5 pce)	0017	Clip Ø 8 (5 pce)
0009	Clip Ø 8 (5 pce)	0018	Hose connector adaptor
		0019	Thermal circuit breaker
		0020	Heating water flow connection elbow
		0021	Hydraulics

**Hydraulic assembly (cont.)**

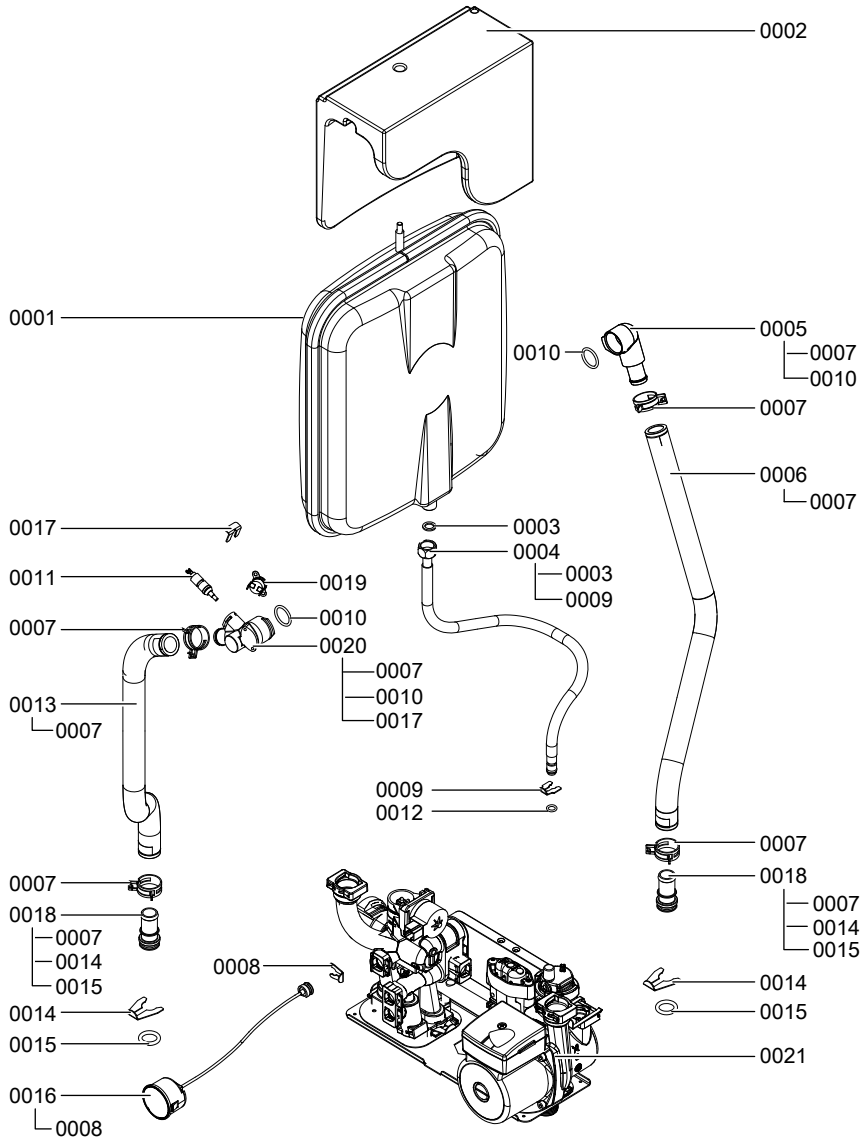

## Combi hydraulic assembly

- |                                       |                                       |
|---------------------------------------|---------------------------------------|
| 0001 Air vent valve                   | 0013 Expansion tank                   |
| 0002 O-ring 34 x 3 (5 pce)            | 0014 Stepper motor adaptor            |
| 0003 Plate heat exchanger             | 0015 Linear stepper motor             |
| 0004 Gasket set, plate heat exchanger | 0016 Oval cap seal (5 pce)            |
| 0005 Safety valve                     | 0017 Water volume controller          |
| 0006 Clip Ø 8 (5 pce)                 | 0018 Temperature sensor               |
| 0007 Safety valve clip (5 pce)        | 0020 Hydraulics                       |
| 0008 Pump motor                       | 0021 Round sealing ring 8 x 2 (5 pce) |
| 0009 Bypass cartridge                 | 0022 O-ring 16 x 3 (5 pce)            |
| 0010 Flow sensor                      | 0023 Check valve                      |
| 0011 Clip Ø 10 (5 pce)                | 0024 Clip Ø 18 (5 pce)                |
| 0012 Clip Ø 16 (5 pce)                |                                       |

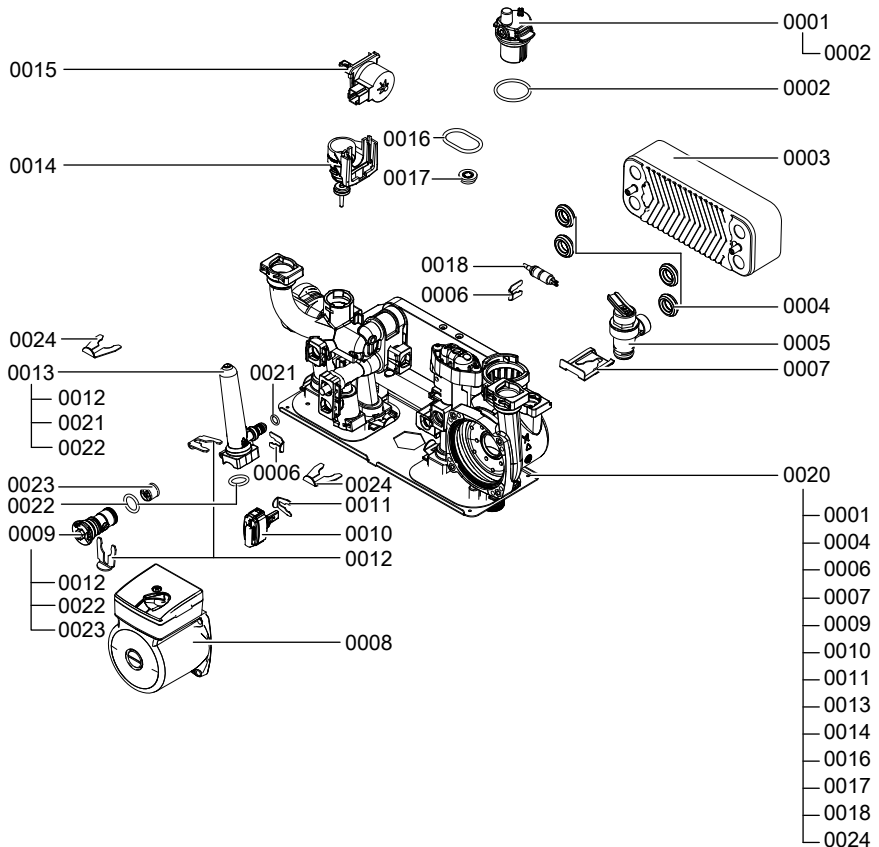

## Control unit assembly

- 0001 Cover, wiring chamber
- 0002 Clip hinge
- 0003 Profiled seal
- 0004 Control unit
- 0005 Cable harness X20
- 0006 Ignition cable with angle plug  
5 k $\Omega$
- 0007 Gas valve connecting cable
- 0008 Fan connecting cable
- 0009 Cable harness stepper motor
- 0010 Fuse 2.5 A (slow) 250 V

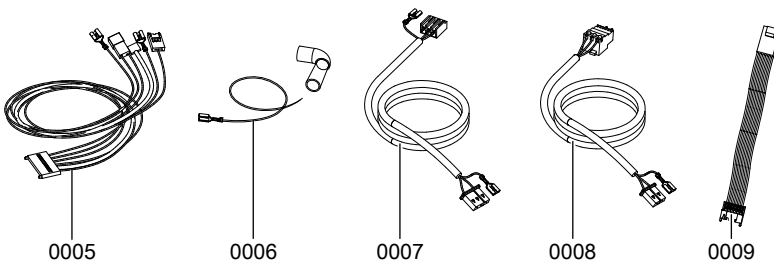
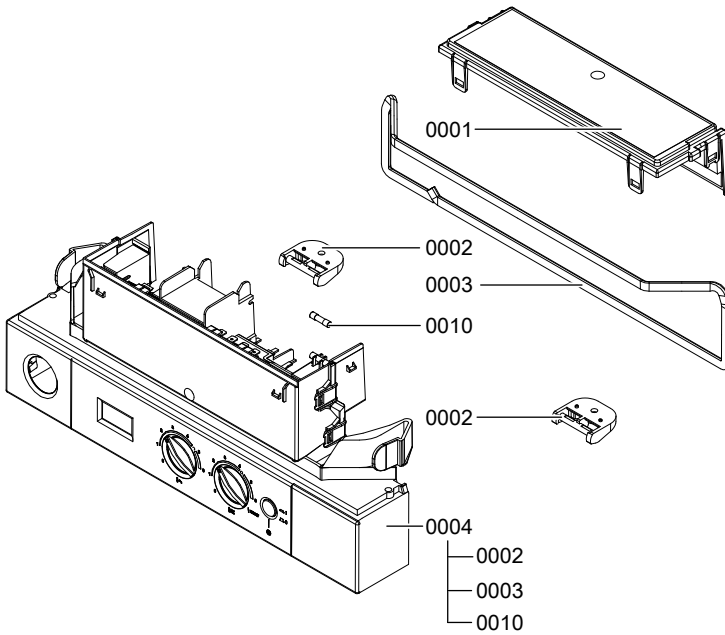

**Miscellaneous assembly**

- 0001 Touch-up spray paint, white
- 0002 Touch-up paint stick, white
- 0003 Special grease

- 0004 Operating instructions
- 0005 Installation and service instructions

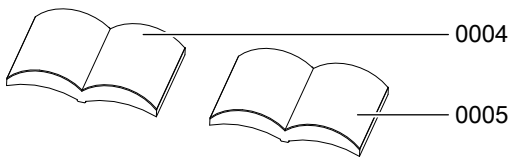
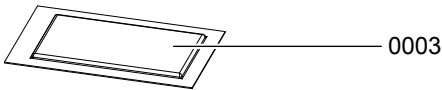
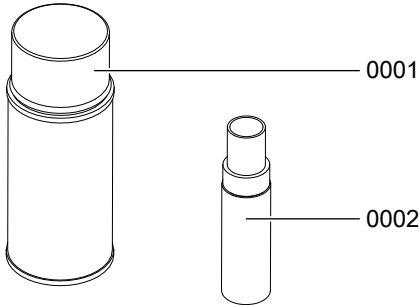

## Specification

### Specification

Rated voltage:	230 V~	Temperature limiter setting:	100 °C (fixed)
Rated frequency:	50Hz	Backup fuse (power supply):	3A
Rated current:	2.0 A~		
Safety category:	I		
IP rating:	IP X4 to EN 60529		

Permissible ambient temperature

- during operation: 0 to +40 °C
- during storage and transport: -20 to +65 °C

### Gas boiler, category II<sub>2H3P</sub>

<b>Rated heating output range in heating mode</b>			
<b>T<sub>V</sub>/T<sub>R</sub> 50/30 °C</b>	<b>kW</b>	<b>6.5 – 21</b>	<b>6.5 – 25</b>
<b>T<sub>V</sub>/T<sub>R</sub> 80/60 °C</b>	<b>kW</b>	<b>5.9 – 19.1</b>	<b>5.9 – 22.8</b>
<b>Rated heating output range for DHW heating</b>	<b>kW</b>	<b>5.9 – 25</b>	<b>5.9 – 29</b>
<b>Rated heat input range</b>	<b>kW</b>	<b>6.1 – 19.6</b>	<b>6.1 – 23.4</b>
<b>Connection values<sup>*1</sup></b>			
relative to the max. load with:			
- Natural gas E	m <sup>3</sup> /h	2.1	2.5
- LPG P	kg/h	1.5	1.8
<b>Power consumption (max.)</b>	<b>W</b>	<b>97</b>	<b>97</b>
<b>DHW heating</b>			
Permissible operating pressure	bar	10	10
Rated water volume at ΔT 35 K (to EN 13203)	l/min	10.2	11.3
Set flow rate (max.)	l/min	12	12
<b>Product ID</b>		<b>CE-0085BT0029</b>	

<sup>\*1</sup> The connection values are only for documentation purposes (e.g. in the gas contract application) or to estimate a supplementary volumetric settings check. Due to the factory settings, the gas pressure must not be altered from these values. Reference: 15 °C, 1013 mbar.

## Declaration of conformity

### Declaration of Conformity for the Vitodens 100-W

We, Viessmann Werke GmbH & Co KG, D-35107 Allendorf, confirm as sole responsible body that the product **Vitodens100-W** complies with the following standards:

EN 297	EN 55 014-2
EN 483	EN 60 335-1
EN 625	EN 60 332-2-102
EN 677	EN 61 000-3-2
EN 806	EN 61 000-3-3
EN 12 897	EN 62 223
EN 55 014-1	

In accordance with the following Directives, this product is designated with **CE-0085**:

92/42/EEC	2006/95/EC
2004/108/EC	2009/142/EC

This product complies with the requirements of the Efficiency Directive (92/42/EEC) for **condensing boilers**.

Allendorf, 01 January 2012

Viessmann Werke GmbH&Co KG



pp. Manfred Sommer

## Keyword index

### B

Boiler water temperature sensor .....	44
Burner gasket.....	31
Burner gauze assembly.....	31
Burner installation.....	34
Burner removal.....	30

### C

Combustion chamber cleaning.....	33
Commissioning.....	20
Condensate.....	13
Condensate drain.....	13, 33
Connection diagram.....	53
Connections.....	11
Control unit, opening.....	15

### D

Declaration of Conformity.....	67
--------------------------------	----

### E

Electrical connections.....	16
-----------------------------	----

### F

Fault code.....	39
Fault messages.....	39
Filling function.....	20
Filling the system.....	20, 21
Flow limiter.....	48
Flue gas temperature sensor.....	47
Flue pipe.....	14
Function sequence.....	38
Fuse.....	50

### G

Gas connection.....	11
Gas supply pressure.....	26
Gas train .....	26
Gas type conversion .....	51
■ LPG.....	22
■ Natural gas.....	51

### H

Heat exchanger cleaning.....	33
------------------------------	----

### I

Ignition.....	32
Ignition electrodes.....	32
Ionisation electrode.....	32

### O

Outlet temperature sensor.....	46
Output matching	
■ Flue pipe length.....	23

### P

Plate heat exchanger.....	49
Power supply.....	17
Pump stage 2.....	24

### R

Reset.....	42
------------	----

### S

Safety chain .....	45
Safety valve.....	13
Siphon.....	14, 33
Specification .....	66
Static pressure.....	26
Supply pressure.....	25
System pressure.....	21

### T

Temperature limiter.....	45
Troubleshooting.....	43

### V

Ventilation air pipe.....	14
Venting.....	22

### W

Wall mounting.....	8
Water connections.....	11



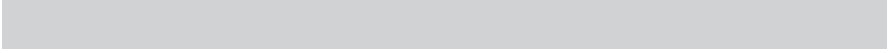





## Applicability

**These service instructions apply for appliances with the following serial numbers (see type plate):**

7501297

7501298

7501823

7501824

Viessmann Werke GmbH&Co KG  
D-35107 Allendorf  
Telephone: +49 6452 70-0  
Fax: +49 6452 70-2780  
[www.viessmann.com](http://www.viessmann.com)

Viessmann Limited  
Hortonwood 30, Telford  
Shropshire, TF1 7YP, GB  
Telephone: +44 1952 675000  
Fax: +44 1952 675040  
E-mail: [info-uk@viessmann.com](mailto:info-uk@viessmann.com)

5609 913 GB Subject to technical modifications.