

Technical guide



VITOCAL 150-A

Type AWO(-M)-E-AC/AWO(-M)-E-AC-AF 151.A

Air source heat pump with electric drive in monoblock design with outdoor and indoor unit

- For room heating, room cooling and DHW heating in heating systems
- Indoor unit with control unit, high efficiency circulation pump for the secondary circuit, instantaneous heating water heater, 4/3-way valve, integral heating water buffer cylinder, expansion vessel and safety assembly

Type AWO(-M)-E-AC/AWO(-M)-E-AC-AF 151.A SP

Equipment as above, with central 230 V~ power supply on the indoor unit

VITOCAL 151-A

Type AWOT(-M)-E-AC/AWOT(-M)-E-AC-AF 151.A

Compact air source heat pump with electric drive in monoblock design with outdoor and indoor unit

- For room heating, room cooling and DHW heating in heating systems
- Indoor unit with control unit, integral 190 l DHW cylinder, high efficiency circulation pump for the secondary circuit, instantaneous heating water heater, 4/3-way valve, integral heating water buffer cylinder, expansion vessel and safety assembly

Type AWOT(-M)-E-AC/AWOT(-M)-E-AC-AF 151.A SP

Equipment as above, with central 230 V~ power supply on the indoor unit

Index

1. Product type designations	5
2. Vitocal 150-A		
2. 1 Product description	6
■ Benefits	6
■ Delivered condition	6
■ Type overview	7
2. 2 Specification	8
■ Specification	8
■ Dimensions – indoor unit	14
■ Outdoor unit dimensions	15
■ Application limits to EN 14511	15
■ Residual heads of the integral circulation pump	15
3. Vitocal 151-A		
3. 1 Product description	16
■ Benefits	16
■ Delivered condition	17
■ Type overview	17
3. 2 Specification	18
■ Specification	18
■ Dimensions – indoor unit	25
■ Outdoor unit dimensions	26
■ Application limits to EN 14511	26
■ Residual heads of integral circulation pump	26
4. Outdoor unit		
4. 1 Product description	27
■ Benefits	27
■ Dimensions	28
5. Curves		
5. 1 Performance graph, outdoor unit type 151.A10, 230 V~	29
■ Heating	29
■ Cooling	31
5. 2 Performance graph, outdoor unit type 151.A10, 400 V~	32
■ Heating	32
■ Cooling	34
5. 3 Performance graph, outdoor unit type 151.A13, 230 V~	35
■ Heating	35
■ Cooling	37
5. 4 Performance graph, outdoor unit type 151.A13, 400 V~	38
■ Heating	38
■ Cooling	40
5. 5 Performance graph, outdoor unit type 151.A16, 230 V~	41
■ Heating	41
■ Cooling	43
5. 6 Performance graph, outdoor unit type 151.A16, 400 V~	44
■ Heating	44
■ Cooling	46
6. Installation accessories		
6. 1 DHW heating with Vitocell 100-V/100-W, type CVWA/CVWB (300 l/390 l/500 l)	47
■ Vitocell 100-V/100-W, type CVWA/CVWB, Vitoppearlwhite	47
■ Immersion heater EHE	51
■ Immersion heater EHE	52
■ Solar heat exchanger set	52
■ Impressed current anode	53
6. 2 DHW heating with Vitocell 100-W, type CVAB (300 l)	53
■ Vitocell 100-W, type CVAB, Vitoppearlwhite	53
■ Immersion heater EHE	58
■ Impressed current anode	59
6. 3 DHW heating with Vitocell 100-W, type CVBC, (300 l)	59
■ Vitocell 100-W, type CVBC, Vitoppearlwhite	59
■ Immersion heater EHE	65
■ Impressed current anode	66
7. Design information		
7. 1 Power supply and tariffs	66
■ Application procedure	66
7. 2 Siting the outdoor unit	66
■ Requirements of the installation location	66
■ Siting	67
■ Types of installation	67
■ Floorstanding installation	67

■ Wall mounting	67
■ Flat roof installation	67
■ Weather influences	68
■ Condensate	68
■ Structure-borne noise insulation and vibration isolation between the building and outdoor unit	68
■ Weight of outdoor units	69
■ Safety zone	69
■ Outdoor unit minimum clearances	70
■ Foundation for installation with support for floorstanding installation (accessories)	71
■ Foundation for installation with anti-vibration feet (accessories)	71
■ Draining condensate via a soakaway	72
■ Draining condensate via waste water system	73
■ Floorstanding installation with support: Line entry above ground level	74
■ Floorstanding installation with support: Line entry below ground level	75
■ Wall mounting with bracket set for wall mounting	76
7. 3 Siting the indoor unit	76
■ Installation room requirements	76
■ Siting requirements	76
■ Minimum room height Vitocal 151-A	77
■ Minimum installation height of Vitocal 150-A	77
■ Minimum clearances Vitocal 150-A	78
■ Minimum clearances Vitocal 151-A	78
■ Pressure points for Vitocal 151-A	79
7. 4 Connection between the indoor and outdoor units	79
■ Cable entry through the wall	79
■ Cable entry through the floor plate	79
7. 5 Electrical connections	80
■ Electrical installation requirements	80
7. 6 Noise emissions	82
■ Principles	82
■ Sound pressure level at different distances to the appliance	83
■ Information on reducing sound emissions	85
7. 7 Sizing the heat pump	85
■ Mono mode operation	85
■ Supplement for DHW heating in mono mode operation	86
■ Supplement for setback mode	86
■ Mono energetic operation	86
7. 8 Hydraulic conditions for the secondary circuit	87
■ Minimum flow rate and minimum system volume	87
■ Systems with an external buffer cylinder connected in parallel	87
■ Systems without external buffer cylinder	87
■ Max. hydraulic system pressure	87
7. 9 Design guide for the secondary circuit	87
■ Further hydraulic data	88
7.10 Water quality	88
■ Heating water	88
7.11 Connection on the DHW side	89
■ Vitocal 150-A	89
■ Vitocal 151-A	90
■ Safety valve	90
■ Automatic thermostatic mixing valve	90
7.12 DHW cylinder selection	90
■ System examples	92
7.13 Cooling mode	92
7.14 Leak test on the refrigerant circuit	93
7.15 Intended use	93
8. Heat pump control unit	
8. 1 Layout and functions	93
■ Modular design	93
■ Functions	95
■ Information on the PlusBus subscribers	95
■ Frost protection function	95
■ Setting the heating curves (slope and level)	95
■ Systems with external buffer cylinder	95
■ Outside temperature sensor	96
8. 2 Specification, heat pump control unit	96
9. Control unit accessories	
9. 1 Overview	97
9. 2 Photovoltaics	97
■ 3-phase electricity meter	97

Index (cont.)

■ 3-phase electricity meter	97
9. 3 Bus cables	97
■ Bus communication cables	97
■ Bus connecting cable	97
9. 4 Sensors	98
■ Immersion temperature sensor	98
9. 5 Heating circuit control unit extension	98
■ Contact thermostat	98
■ Contact thermostat	98
■ Immersion thermostat	99
■ EM-MX mixer extension kit with integral mixer motor	99
■ EM-M1 mixer extension kit for separate mixer motor	100
10. Keyword index	101

Product type designations

Vitocal 151-A, type

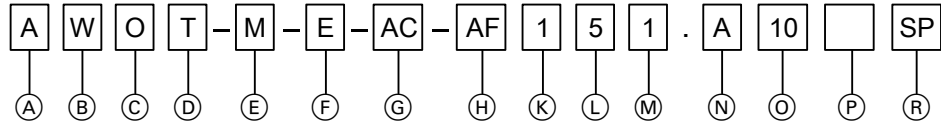

Pos.	Value	Meaning
Ⓐ	Medium, primary circuit	
	A	Air
	B	Brine
	HA	Hybrid Air
Ⓑ	W	Water
	Medium, secondary circuit	
Ⓒ	Model, part 1	
	B	Refrigerant circuit in split version (Bi -block)
	C	Circulation pumps and/or 3-way diverter valve installed (Compact)
	H	High temperature version (High temperature)
	O	Outdoor installation (Outdoor)
	S	Heat pump, stage 2 without heat pump control unit (Slave)
Ⓓ	T	Compact heat pump (Tower)
	Model, part 2	
	I	Indoor installation (Indoor)
Ⓔ	T	Compact heat pump (Tower)
	Outdoor unit power supply	
	M	230 V/50 Hz (Monophase)
Ⓕ	Empty	400 V/50 Hz
	Electric instantaneous heating water heater	
	E	Electric heating built into heat pump
Ⓖ	Empty	Not built-in
	Cooling function	
	AC	Active cooling
Ⓗ	NC	Natural cooling

Pos.	Value	Meaning
Ⓖ	Ribbon heater for condensate pan	
	AF	Built into outdoor unit (Anti Freeze)
	Empty	Not built-in
Ⓚ	Viessmann product segment	
	1	100
	2	200
	3	300
Ⓛ	Flow temperature and DHW cylinder	
	0	Normal flow temperature, separate DHW cylinder required
	1/2/3	Normal flow temperature, built-in DHW cylinder
	4	Normal flow temperature, built-in DHW cylinder, with solar DHW heating
	5	High flow temperature, with built-in DHW cylinder, or separate DHW cylinder required
Ⓜ	Heat pumps: Number of compressors in refrigerant circuit	
	1	1 compressor
	2	2 compressors (connected in parallel)
	Hybrid appliances: Number of heat sources	
Ⓝ	2	2 heat sources, e.g. 1 compressor and 1 burner
	A to ...	Product generation
Ⓞ	Output class, similar to max. output in kW at A7/W35	
	Hydraulics, indoor unit	
	2C	2 integral heating/cooling circuits
Ⓟ	Empty	1 integral heating/cooling circuit
	Indoor unit equipment	
	SP	Central power supply 1/N/PE 230 V/50 Hz
Ⓡ	NEV	No expansion vessel

2.1 Product description

Benefits

Indoor unit

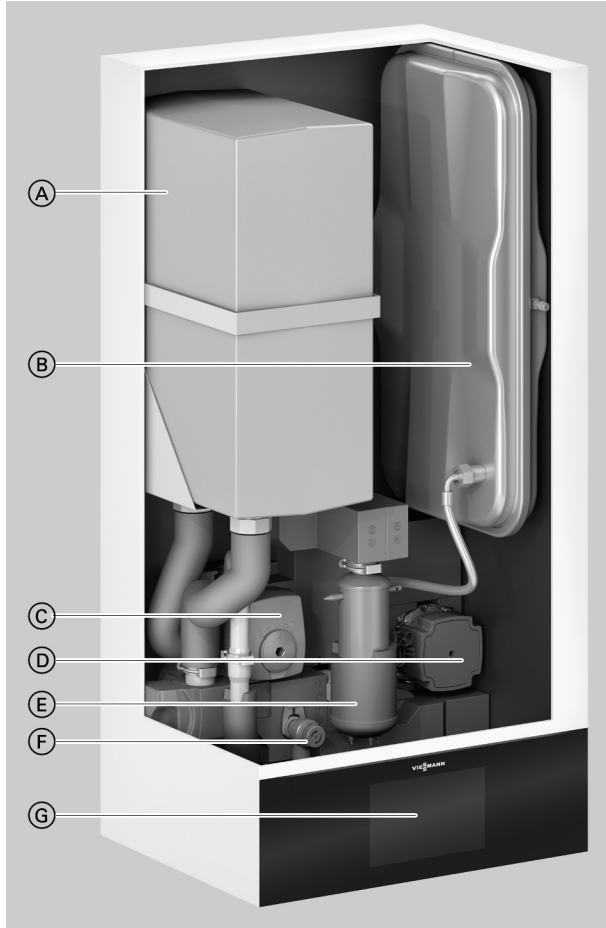

- Ⓐ Heating water buffer cylinder
- Ⓑ Expansion vessel
- Ⓒ 4/3-way valve
- Ⓓ Secondary pump (high efficiency circulation pump)
- Ⓔ Instantaneous heating water heater
- Ⓕ Safety valve
- Ⓖ Heat pump control unit

- Low running costs thanks to high COP (coefficient of performance) to EN 14511: Up to 5.0 at A7/W35
- Output control and DC inverter for high efficiency in partial load operation
- Maximum flow temperature of up to 70 °C at an outside temperature of -10 °C enables use in both new build and modernisation projects.
- Self-optimising control of the flow rate via Viessmann Hydro Auto-Control
- Environmentally responsible, natural refrigerant R290 with a particularly low GWP of 0.02 (GWP = Global Warming Potential)

- Convenient reversible design for heating and cooling
- Quiet operation thanks to Advanced Acoustic Design (AAD)
- Web-enabled through integral WiFi or service link
- Operation, optimisation, maintenance and service via ViCare app and Vitoguide
- Guided commissioning via Vitoguide
- Individual room control with components from ViCare Smart Climate

Delivered condition

Indoor unit

- Integral 4/3-way valve for central heating/DHW heating/bypass
- Integral high efficiency circulation pump for the secondary circuit or heating/cooling circuit 1
- Integral instantaneous heating water heater
- Integral 16 l buffer cylinder
- Integral safety valve and digital pressure gauge
- Weather-compensated heat pump control unit with outside temperature sensor
- Flow sensor

- Wall mounting bracket, standard connection pipes
- Expansion vessel 10 l

- Type ...SP
Central 230 V~ power supply with line protection



Outdoor unit



- Inverter-controlled compressor, 4-way diverter valve, electronic expansion valve, evaporator, condenser, EC fan
- Factory-filled with refrigerant R290
- Heating water filter upstream of condenser
- Transport aid for outdoor unit

Vitocal 150-A (cont.)

- Type AWO(-M)-E-AC-AF:
With integral electric ribbon heater for the condensate pan

Type overview

Type	Heating/cooling circuits		Rated voltage			Central indoor unit power supply	Condensate pan heating
	Internal hydraulics	External buffer cylinder					
AWO-E-AC 151.A	1	1 to 4	230 V~	400 V~/ 230 V~	400 V~	—	—
AWO-M-E-AC 151.A	1	1 to 4	230 V~	400 V~/ 230 V~	230 V~	—	—
AWO-M-E-AC 151.A SP	1	1 to 4	230 V~	230 V~	230 V~	X	—
AWO-E-AC-AF 151.A	1	1 to 4	230 V~	400 V~/ 230 V~	400 V~	—	X
AWO-M-E-AC-AF 151.A	1	1 to 4	230 V~	400 V~/ 230 V~	230 V~	—	X
AWO-M-E-AC-AF 151.A SP	1	1 to 4	230 V~	230 V~	230 V~	X	X

-  Control unit/PCB, indoor unit
-  Outdoor unit
-  Instantaneous heating water heater

2.2 Specification

Specification

Heat pumps with 400 V~ outdoor unit

Type AWO-E-AC/AWO-E-AC-AF	151.A10	151.A13	151.A16	
Heating performance data to EN 14511 (A2/W35)				
Rated heating output	kW	5.8	6.7	7.6
Power consumption	kW	1.41	1.76	2.00
Coefficient of performance ϵ (COP) in heating mode		4.1	3.8	3.8
Output control	kW	2.2 to 11.0	2.6 to 12.3	3.0 to 13.7
Heating performance data to EN 14511 (A7/W35, 5 K spread)				
Rated heating output	kW	7.3	8.1	9.1
Fan speed	rpm	430	440	567
Air flow rate	m ³ /h	4045	4188	5393
Power consumption	kW	1.46	1.65	1.86
Coefficient of performance ϵ (COP) in heating mode		5.0	4.9	4.9
Output control	kW	2.6 to 12.0	3.0 to 13.4	3.3 to 14.9
Heating performance data to EN 14511 (A-7/W35)				
Rated heating output	kW	9.7	11.1	12.4
Power consumption	kW	3.23	3.96	4.4
Coefficient of performance ϵ (COP) in heating mode		3.0	2.8	2.8
Air intake temperature				
Cooling mode				
– Min.	°C	10	10	10
– Max.	°C	45	45	45
Heating mode				
– Min.	°C	–20	–20	–20
– Max.	°C	40	40	40
Heating water (secondary circuit)				
Capacity excl. expansion vessel	l	18	18	18
Heat pump circuit minimum flow rate (defrosting)	l/h	1000	1000	1000
Max. flow temperature	°C	70	70	70
Outdoor unit electrical values				
Rated voltage		3/N/PE 400 V/50 Hz		
Max. operating current	A	11.5	11.5	11.5
Cos ϕ		0.92	0.92	0.92
Compressor starting current, inverter controlled	A	< 10	< 10	< 10
Starting current, compressor with stalled armature	A	< 10	< 10	< 10
Fuse protection		B16A	B16A	B16A
IP rating		IP X4	IP X4	IP X4
Indoor unit electrical values				
PCB				
– Rated voltage		1/N/PE 230 V/50 Hz		
– Power supply fuse protection		1 x B16A	1 x B16A	1 x B16A
– Internal fuse protection		6.3 A H (slow)/250 V~		
Instantaneous heating water heater				
– Rated voltage		3/N/PE 400 V/50 Hz		
– Heating output	kW	8	8	8
– Power supply fuse protection		3 x B16A	3 x B16A	3 x B16A
Max. power consumption				
Fan	W	2 x 140	2 x 140	2 x 140
Outdoor unit	kW	4.8	5.4	5.4
Secondary pump (PWM)	W	60	60	60
Control unit/PCB, indoor unit	W	65	65	65
Control unit/PCB power, indoor unit	W	1000	1000	1000



Vitocal 150-A (cont.)

Type AWO-E-AC/AWO-E-AC-AF		151.A10	151.A13	151.A16
Mobile data transfer				
WiFi				
– Transfer standard		IEEE 802.11 b/g/n	IEEE 802.11 b/g/n	IEEE 802.11 b/g/n
– Frequency range	MHz	2000 to 2483.5	2000 to 2483.5	2000 to 2483.5
– Max. transmission power	dBm	+15	+15	+15
Low power radio				
– Transfer standard		IEEE 802.15.4	IEEE 802.15.4	IEEE 802.15.4
– Frequency range	MHz	2000 to 2483.5	2000 to 2483.5	2000 to 2483.5
– Max. transmission power	dBm	+6	+6	+6
Service link				
– Transfer standard		LTE-CAT-NB1	LTE-CAT-NB1	LTE-CAT-NB1
– Frequency range band 3	MHz	1710 to 1785	1710 to 1785	1710 to 1785
– Frequency range band 8	MHz	880 to 915	880 to 915	880 to 915
– Frequency range band 20	MHz	832 to 862	832 to 862	832 to 862
– Max. transmission power	dBm	+23	+23	+23
Refrigerant circuit				
Refrigerant				
		R290	R290	R290
– Safety group		A3	A3	A3
– Charge weight	kg	2	2	2
– Global warming potential (GWP) ^{*3}		0.02	0.02	0.02
– CO ₂ equivalent	t	0.00004	0.00004	0.00004
Compressor (hermetically sealed)				
– Oil in compressor	Type	Twin rotary	Twin rotary	Twin rotary
– Oil volume in compressor	Type	HAF68	HAF68	HAF68
Permissible operating pressure	l	1.150 ±0.020	1.150 ±0.020	1.150 ±0.020
– High pressure side	bar	30.3	30.3	30.3
	MPa	3.03	3.03	3.03
– Low pressure side	bar	30.3	30.3	30.3
	MPa	3.03	3.03	3.03
Outdoor unit dimensions				
Total length	mm	600	600	600
Total width	mm	1144	1144	1144
Total height	mm	1382	1382	1382
Indoor unit dimensions				
Total length	mm	360	360	360
Total width	mm	450	450	450
Total height	mm	920	920	920
Total weight				
Indoor unit				
– Empty	kg	48	48	48
– Filled (max.)	kg	74	74	74
Outdoor unit	kg	197	197	197
Permissible operating pressure on the secondary side				
	bar	3	3	3
	MPa	0.3	0.3	0.3
Connections with connection pipes supplied				
Heating water flow/return, heating/cooling circuits or heating water buffer cylinder	mm	Cu 28 x 1.0	Cu 28 x 1.0	Cu 28 x 1.0
Heating water flow/return, DHW cylinder	mm	Cu 22 x 1.0	Cu 22 x 1.0	Cu 22 x 1.0
Outdoor unit heating water flow/return	mm	Cu 28 x 1.0	Cu 28 x 1.0	Cu 28 x 1.0
Length of connection line indoor unit — outdoor unit (hydraulic connection set)	m	5 to 20	5 to 20	5 to 20
Sound power of the outdoor unit at rated heating output (Measurements with reference to EN 12102/EN ISO 9614-2)				
Assessed total sound power level at A7/W55				
– ErP	dB(A)	56	56	56
– Max.	dB(A)	66	66	66
– In night mode	dB(A)	59	59	59
Energy efficiency class to Commission Regulation (EU) No 813/2013				
Heating, average climatic conditions				
– Low temperature application (W35)		A+++	A+++	A+++
– Medium temperature application (W55)		A++	A++	A++

Vitocal 150-A (cont.)

Type AWO-E-AC/AWO-E-AC-AF	151.A10	151.A13	151.A16
Heating performance data to Commission Regulation (EU) No. 813/2013 (average climatic conditions)			
Low temperature application (W35)			
– Energy efficiency η_s	%	190	178
– Rated heating output P_{rated}	kW	9.8	12.4
– Seasonal coefficient of performance (SCOP)		4.825	4.52
Medium temperature application (W55)			
– Energy efficiency η_s	%	145	141
– Rated heating output P_{rated}	kW	9.37	12.1
– Seasonal coefficient of performance (SCOP)		3.7	3.6
Heat pumps with 230 V~ outdoor unit			
Type AWO-M-E-AC/AWO-M-E-AC-AF	151.A10	151.A13	151.A16
Heating performance data to EN 14511 (A2/W35)			
Rated heating output	kW	5.8	6.7
Power consumption	kW	1.41	1.76
Coefficient of performance ϵ (COP) in heating mode		4.1	3.8
Output control	kW	2.2 to 11.0	2.6 to 12.3
Heating performance data to EN 14511 (A7/W35, 5 K spread)			
Rated heating output	kW	7.3	8.1
Fan speed	rpm	430	440
Air flow rate	m ³ /h	4045	4188
Power consumption	kW	1.46	1.65
Coefficient of performance ϵ (COP) in heating mode		5.0	4.9
Output control	kW	2.6 to 12.0	3.0 to 13.4
Heating performance data to EN 14511 (A–7/W35)			
Rated heating output	kW	9.7	11.1
Power consumption	kW	3.23	3.96
Coefficient of performance ϵ (COP) in heating mode		3.0	2.8
Air intake temperature			
Cooling mode			
– Min.	°C	10	10
– Max.	°C	45	45
Heating mode			
– Min.	°C	–20	–20
– Max.	°C	40	40
Heating water (secondary circuit)			
Capacity excl. expansion vessel	l	18	18
Heat pump circuit minimum flow rate (defrosting)	l/h	1000	1000
Max. flow temperature	°C	70	70
Outdoor unit electrical values			
Rated voltage		1/N/PE 230 V/50 Hz	
Max. operating current	A	21	23
Cos ϕ		0.92	0.92
Compressor starting current, inverter controlled	A	< 10	< 10
Starting current, compressor with stalled armature	A	< 10	< 10
Fuse protection		B25A	B25A
IP rating		IP X4	IP X4
Indoor unit electrical values			
PCB			
– Rated voltage		1/N/PE 230 V/50 Hz	
– Power supply fuse protection		1 x B16A	1 x B16A
– Internal fuse protection		6.3 A H (slow)/250 V~	
Instantaneous heating water heater			
– Rated voltage		3 x 1/N/PE 400 V/50 Hz	
– Heating output	kW	8	8
– Power supply fuse protection		3 x B16A	3 x B16A
Max. power consumption			
Fan	W	2 x 140	2 x 140
Outdoor unit	kW	4.8	5.4
Secondary pump (PWM)	W	60	60
Control unit/PCB, indoor unit	W	65	65
Control unit/PCB power, indoor unit	W	1000	1000

Vitocal 150-A (cont.)

Type AWO-M-E-AC/AWO-M-E-AC-AF		151.A10	151.A13	151.A16
Mobile data transfer				
WiFi				
– Transfer standard		IEEE 802.11 b/g/n	IEEE 802.11 b/g/n	IEEE 802.11 b/g/n
– Frequency range	MHz	2000 to 2483.5	2000 to 2483.5	2000 to 2483.5
– Max. transmission power	dBm	+15	+15	+15
Low power radio				
– Transfer standard		IEEE 802.15.4	IEEE 802.15.4	IEEE 802.15.4
– Frequency range	MHz	2000 to 2483.5	2000 to 2483.5	2000 to 2483.5
– Max. transmission power	dBm	+6	+6	+6
Service link				
– Transfer standard		LTE-CAT-NB1	LTE-CAT-NB1	LTE-CAT-NB1
– Frequency range band 3	MHz	1710 to 1785	1710 to 1785	1710 to 1785
– Frequency range band 8	MHz	880 to 915	880 to 915	880 to 915
– Frequency range band 20	MHz	832 to 862	832 to 862	832 to 862
– Max. transmission power	dBm	+23	+23	+23
Refrigerant circuit				
Refrigerant				
		R290	R290	R290
– Safety group		A3	A3	A3
– Charge weight	kg	2	2	2
– Global warming potential (GWP) ^{*3}		0.02	0.02	0.02
– CO ₂ equivalent	t	0.00004	0.00004	0.00004
Compressor (hermetically sealed)				
– Oil in compressor	Type	Twin rotary	Twin rotary	Twin rotary
– Oil volume in compressor	Type	HAF68	HAF68	HAF68
Permissible operating pressure	l	1.150 ±0.020	1.150 ±0.020	1.150 ±0.020
– High pressure side	bar	30.3	30.3	30.3
	MPa	3.03	3.03	3.03
– Low pressure side	bar	30.3	30.3	30.3
	MPa	3.03	3.03	3.03
Outdoor unit dimensions				
Total length	mm	600	600	600
Total width	mm	1144	1144	1144
Total height	mm	1382	1382	1382
Indoor unit dimensions				
Total length	mm	360	360	360
Total width	mm	450	450	450
Total height	mm	920	920	920
Total weight				
Indoor unit				
– Empty	kg	48	48	48
– Filled (max.)	kg	74	74	74
Outdoor unit	kg	191	191	191
Permissible operating pressure on the secondary side				
	bar	3	3	3
	MPa	0.3	0.3	0.3
Connections with connection pipes supplied				
Heating water flow/return, heating/cooling circuits or heating water buffer cylinder	mm	Cu 28 x 1.0	Cu 28 x 1.0	Cu 28 x 1.0
Heating water flow/return, DHW cylinder	mm	Cu 22 x 1.0	Cu 22 x 1.0	Cu 22 x 1.0
Outdoor unit heating water flow/return	mm	Cu 28 x 1.0	Cu 28 x 1.0	Cu 28 x 1.0
Length of connection line indoor unit — outdoor unit (hydraulic connection set)	m	5 to 20	5 to 20	5 to 20
Sound power of the outdoor unit at rated heating output (Measurements with reference to EN 12102/EN ISO 9614-2)				
Assessed total sound power level at A7/W55				
– ErP	dB(A)	56	56	56
– Max.	dB(A)	66	66	66
– In night mode	dB(A)	59	59	59
Energy efficiency class to Commission Regulation (EU) No 813/2013				
Heating, average climatic conditions				
– Low temperature application (W35)		A+++	A+++	A+++
– Medium temperature application (W55)		A++	A++	A++

Vitocal 150-A (cont.)

Type AWO-M-E-AC/AWO-M-E-AC-AF	151.A10	151.A13	151.A16
Heating performance data to Commission Regulation (EU) No. 813/2013 (average climatic conditions)			
Low temperature application (W35)			
– Energy efficiency η_s	%	190	178
– Rated heating output P_{rated}	kW	9.8	12.4
– Seasonal coefficient of performance (SCOP)		4.825	4.52
Medium temperature application (W55)			
– Energy efficiency η_s	%	145	141
– Rated heating output P_{rated}	kW	9.37	12.1
– Seasonal coefficient of performance (SCOP)		3.7	3.6
Heat pumps with 230 V~ outdoor unit			
Type AWO-M-E-AC/AWO-M-E-AC-AF	151.A10 SP	151.A13 SP	151.A16 SP
Heating performance data to EN 14511 (A2/W35)			
Rated heating output	kW	5.8	6.7
Power consumption	kW	1.41	1.76
Coefficient of performance ϵ (COP) in heating mode		4.1	3.8
Output control	kW	2.2 to 11.0	2.6 to 12.3
Heating performance data to EN 14511 (A7/W35, 5 K spread)			
Rated heating output	kW	7.3	8.1
Fan speed	rpm	430	440
Air flow rate	m ³ /h	4045	4188
Power consumption	kW	1.46	1.65
Coefficient of performance ϵ (COP) in heating mode		5.0	4.9
Output control	kW	2.6 to 12.0	3.0 to 13.4
Heating performance data to EN 14511 (A–7/W35)			
Rated heating output	kW	9.7	11.1
Power consumption	kW	3.23	3.96
Coefficient of performance ϵ (COP) in heating mode		3.0	2.8
Air intake temperature			
Cooling mode			
– Min.	°C	10	10
– Max.	°C	45	45
Heating mode			
– Min.	°C	–20	–20
– Max.	°C	40	40
Heating water (secondary circuit)			
Capacity excl. expansion vessel	l	18	18
Heat pump circuit minimum flow rate (defrosting)	l/h	1000	1000
Max. flow temperature	°C	70	70
Outdoor unit electrical values			
Rated voltage		1/N/PE 230 V/50 Hz	
Max. operating current	A	21	23
Cos ϕ		0.92	0.92
Compressor starting current, inverter controlled	A	< 10	< 10
Starting current, compressor with stalled armature	A	< 10	< 10
Fuse protection		B25A	B25A
IP rating		IP X4	IP X4
Indoor unit electrical values			
PCB			
– Rated voltage		1/N/PE 230 V/50 Hz	
– Internal fuse protection		6.3 A H (slow)/250 V~	
Instantaneous heating water heater			
– Heating output	kW	4.8	4.8
Power supply, indoor unit			
– Rated voltage		1/N/PE 230 V/50 Hz	
– Power supply fuse protection		1 x B32A	1 x B32A
Max. power consumption			
Fan	W	2 x 140	2 x 140
Outdoor unit	kW	4.8	5.4
Secondary pump (PWM)	W	60	60
Control unit/PCB, indoor unit	W	65	65
Control unit/PCB power, indoor unit	W	1000	1000

Vitocal 150-A (cont.)

Type AWO-M-E-AC/AWO-M-E-AC-AF		151.A10 SP	151.A13 SP	151.A16 SP
Mobile data transfer				
WiFi				
– Transfer standard		IEEE 802.11 b/g/n	IEEE 802.11 b/g/n	IEEE 802.11 b/g/n
– Frequency range	MHz	2000 to 2483.5	2000 to 2483.5	2000 to 2483.5
– Max. transmission power	dBm	+15	+15	+15
Low power radio				
– Transfer standard		IEEE 802.15.4	IEEE 802.15.4	IEEE 802.15.4
– Frequency range	MHz	2000 to 2483.5	2000 to 2483.5	2000 to 2483.5
– Max. transmission power	dBm	+6	+6	+6
Service link				
– Transfer standard		LTE-CAT-NB1	LTE-CAT-NB1	LTE-CAT-NB1
– Frequency range band 3	MHz	1710 to 1785	1710 to 1785	1710 to 1785
– Frequency range band 8	MHz	880 to 915	880 to 915	880 to 915
– Frequency range band 20	MHz	832 to 862	832 to 862	832 to 862
– Max. transmission power	dBm	+23	+23	+23
Refrigerant circuit				
Refrigerant				
– Safety group		R290 A3	R290 A3	R290 A3
– Charge weight	kg	2	2	2
– Global warming potential (GWP) ^{*3}		0.02	0.02	0.02
– CO ₂ equivalent	t	0.00004	0.00004	0.00004
Compressor (hermetically sealed)				
– Oil in compressor	Type	Twin rotary	Twin rotary	Twin rotary
– Oil volume in compressor	l	HAF68 1.150 ±0.020	HAF68 1.150 ±0.020	HAF68 1.150 ±0.020
Permissible operating pressure				
– High pressure side	bar	30.3	30.3	30.3
	MPa	3.03	3.03	3.03
– Low pressure side	bar	30.3	30.3	30.3
	MPa	3.03	3.03	3.03
Outdoor unit dimensions				
Total length	mm	600	600	600
Total width	mm	1144	1144	1144
Total height	mm	1382	1382	1382
Indoor unit dimensions				
Total length	mm	360	360	360
Total width	mm	450	450	450
Total height	mm	920	920	920
Total weight				
Indoor unit				
– Empty	kg	47	47	47
– Filled (max.)	kg	74	74	74
Outdoor unit	kg	191	191	191
Permissible operating pressure on the secondary side				
	bar	3	3	3
	MPa	0.3	0.3	0.3
Connections with connection pipes supplied				
Heating water flow/return, heating/cooling circuits or heating water buffer cylinder	mm	Cu 28 x 1.0	Cu 28 x 1.0	Cu 28 x 1.0
Heating water flow/return, DHW cylinder	mm	Cu 22 x 1.0	Cu 22 x 1.0	Cu 22 x 1.0
Outdoor unit heating water flow/return	mm	Cu 28 x 1.0	Cu 28 x 1.0	Cu 28 x 1.0
Length of connection line indoor unit — outdoor unit (hydraulic connection set)	m	5 to 20	5 to 20	5 to 20
Sound power of the outdoor unit at rated heating output (Measurements with reference to EN 12102/EN ISO 9614-2) Assessed total sound power level at A7/W55				
– ErP	dB(A)	56	56	56
– Max.	dB(A)	66	66	66
– In night mode	dB(A)	59	59	59
Energy efficiency class to Commission Regulation (EU) No 813/2013				
Heating, average climatic conditions				
– Low temperature application (W35)		A+++	A+++	A+++
– Medium temperature application (W55)		A++	A++	A++

Vitocal 150-A (cont.)

Type AWO-M-E-AC/AWO-M-E-AC-AF	151.A10 SP	151.A13 SP	151.A16 SP
Heating performance data to Commission Regulation (EU) No. 813/2013 (average climatic conditions)			
Low temperature application (W35)			
– Energy efficiency η_s	%	190	178
– Rated heating output P_{rated}	kW	9.8	12.4
– Seasonal coefficient of performance (SCOP)		4.825	4.52
Medium temperature application (W55)			
– Energy efficiency η_s	%	145	141
– Rated heating output P_{rated}	kW	9.37	12.1
– Seasonal coefficient of performance (SCOP)		3.7	3.6

Dimensions – indoor unit

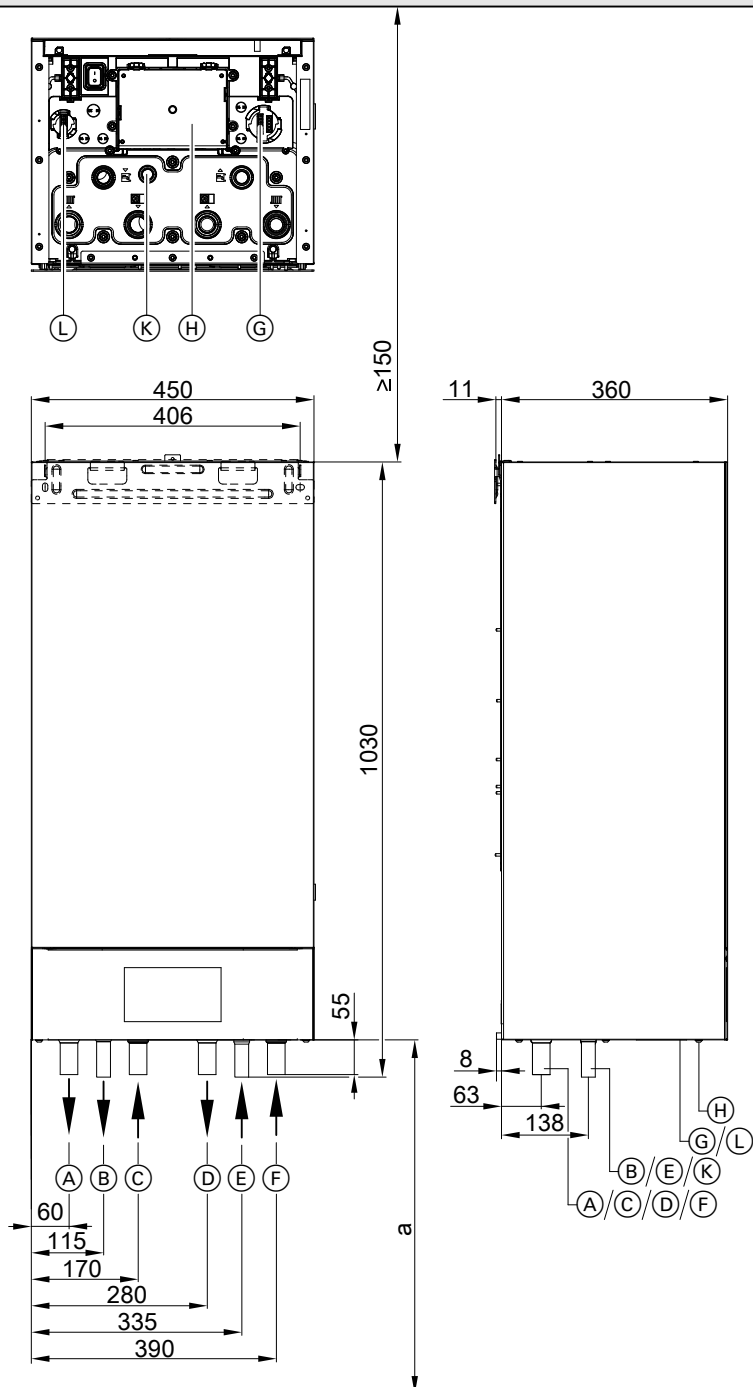

Vitocal 150-A (cont.)

- a Min. installation height
Depends on whether the programming unit is fitted below or above.
- (A) Secondary circuit flow (heating/cooling circuit 1 / heating water buffer cylinder), connection Cu 28 x 1.0 mm
 - (B) DHW cylinder flow (on the heating water side), connection Cu 22 x 1.0 mm
 - (C) Outdoor unit flow (indoor unit heating water inlet), connection Cu 28 x 1.0 mm
 - (D) Outdoor unit return (indoor unit heating water outlet), connection Cu 28 x 1.0 mm
 - (E) DHW cylinder return (on the heating water side), connection Cu 22 x 1.0 mm
 - (F) Secondary circuit return (heating/cooling circuit 1/heating water buffer cylinder), connection Cu 28 x 1.0 mm
 - (G) Extra low voltage (ELV) connection sockets < 42 V
 - (H) Junction box 230 V~
 - (K) Drain hose safety valve
 - (L) Extra low voltage (ELV) connection socket < 42 V

Outdoor unit dimensions

See page 28 onwards.

Application limits to EN 14511

Heating

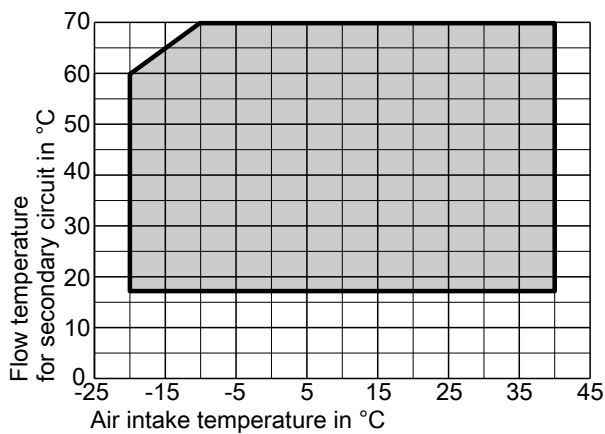

Cooling

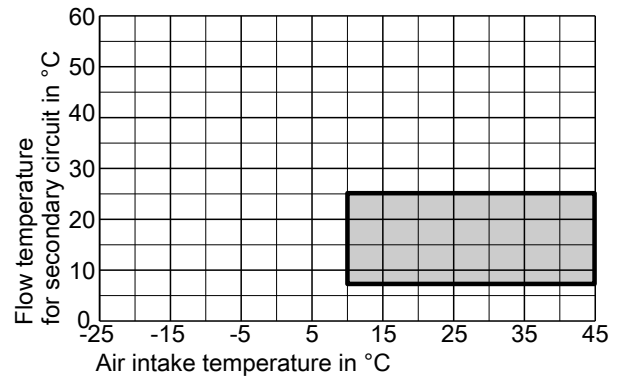

Residual heads of the integral circulation pump

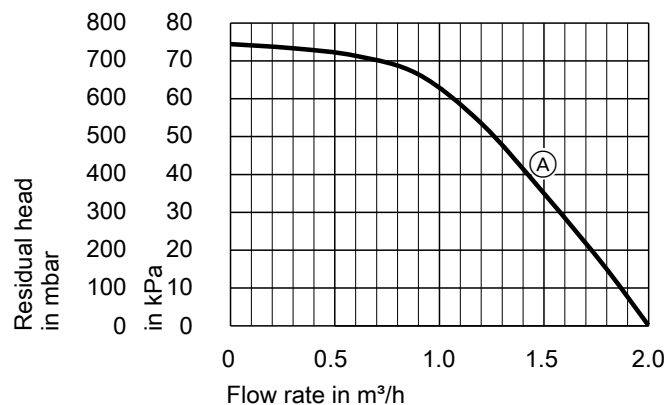

- (A) Secondary pump/circulation pump for heating/cooling circuit 1

3.1 Product description

Benefits

Indoor unit

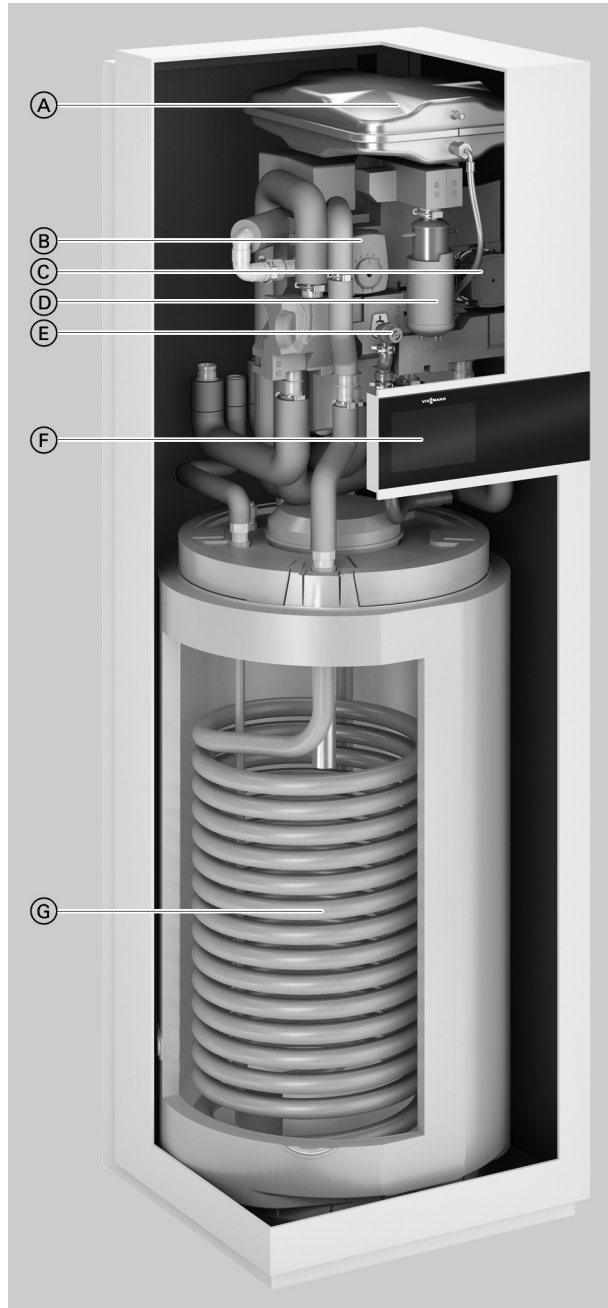

- Ⓐ Expansion vessel
- Ⓑ 4/3-way valve
- Ⓒ Secondary pump (high efficiency circulation pump)
- Ⓓ Instantaneous heating water heater
- Ⓔ Safety valve
- Ⓕ Heat pump control unit
- Ⓖ DHW cylinder 190 l

- Integral 190 l DHW cylinder
- Low running costs thanks to high COP (coefficient of performance) to EN 14511: Up to 5.0 at A7/W35
- Output control and DC inverter for high efficiency in partial load operation
- Maximum flow temperature of up to 70 °C at an outside temperature of -10 °C enables use in both new build and modernisation projects.
- Self-optimising control of the flow rate via Viessmann Hydro Auto-Control

- Environmentally responsible, natural refrigerant R290 with a particularly low GWP of 0.02 (GWP = Global Warming Potential)
- Convenient reversible design for heating and cooling
- Quiet operation thanks to Advanced Acoustic Design (AAD)
- Web-enabled through integral WiFi or service link
- Operation, optimisation, maintenance and service via ViCare app and Vitoguide
- Guided commissioning via Vitoguide
- Individual room control with components from ViCare Smart Climate

Vitocal 151-A (cont.)

Delivered condition

Indoor unit

- Integral steel DHW cylinder with Ceraprotect enamel coating, protected from corrosion by a protective magnesium anode, with thermal insulation
- Integral 4/3-way valve for central heating/DHW heating/bypass
- Integral high efficiency circulation pump for the secondary circuit or heating/cooling circuit 1
- Integral instantaneous heating water heater
- Integral 16 l buffer cylinder
- Integral safety valve and digital pressure gauge
- Weather-compensated heat pump control unit with outside temperature sensor



- Flow sensor
- Expansion vessel 10 l



- Type ...**SP**
Central 230 V~ power supply with line protection

Outdoor unit

- Inverter-controlled compressor, 4-way diverter valve, electronic expansion valve, evaporator, condenser, EC fan
- Factory-filled with refrigerant R290
- Heating water filter upstream of condenser
- Transport aid for outdoor unit
- Type AWOT(-M)-E-AC-**AF**:
With integral electric ribbon heater for the condensate pan

Type overview

Type	Heating/cooling circuits		Rated voltage			Central indoor unit power supply	Condensate pan heating
	Internal hydraulics	External buffer cylinder					
AWOT-E-AC 151.A	1	1 to 4	230 V~	400 V~/ 230 V~	400 V~	—	—
AWOT-M-E-AC 151.A	1	1 to 4	230 V~	400 V~/ 230 V~	230 V~	—	—
AWOT-M-E-AC 151.A SP	1	1 to 4	230 V~	230 V~	230 V~	X	—
AWOT-E-AC-AF 151.A	1	1 to 4	230 V~	400 V~/ 230 V~	400 V~	—	X
AWOT-M-E-AC-AF 151.A	1	1 to 4	230 V~	400 V~/ 230 V~	230 V~	—	X
AWOT-M-E-AC-AF 151.A SP	1	1 to 4	230 V~	230 V~	230 V~	X	X

-  Control unit/PCB, indoor unit
-  Outdoor unit
-  Instantaneous heating water heater

3.2 Specification

Specification

Heat pumps with 400 V~ outdoor unit

Type AWOT-E-AC	151.A10	151.A13	151.A16	
Heating performance data to EN 14511 (A2/W35)				
Rated heating output	kW	5.8	6.7	7.6
Air flow rate				
Power consumption	kW	1.41	1.76	2.00
Coefficient of performance ϵ (COP) in heating mode		4.1	3.8	3.8
Output control	kW	2.2 to 11.0	2.6 to 12.3	3.0 to 13.7
Heating performance data to EN 14511 (A7/W35, 5 K spread)				
Rated heating output	kW	7.3	8.1	9.1
Fan speed	rpm	430	440	567
Air flow rate	m ³ /h	4045	4188	5393
Power consumption	kW	1.46	1.65	1.86
Coefficient of performance ϵ (COP) in heating mode		5.0	4.9	4.9
Output control	kW	2.6 to 12.0	3.0 to 13.4	3.3 to 14.9
Heating performance data to EN 14511 (A-7/W35)				
Rated heating output	kW	9.7	11.1	12.4
Power consumption	kW	3.23	3.96	4.4
Coefficient of performance ϵ (COP) in heating mode		3.0	2.8	2.8
Air intake temperature				
Cooling mode				
– Min.	°C	10	10	10
– Max.	°C	45	45	45
Heating mode				
– Min.	°C	-20	-20	-20
– Max.	°C	40	40	40
Heating water (secondary circuit)				
Capacity excl. expansion vessel	l	10	10	10
Heat pump circuit minimum flow rate (defrosting)	l/h	1000	1000	1000
Max. flow temperature	°C	70	70	70
Outdoor unit electrical values				
Rated voltage, compressor		3/N/PE 400 V/50 Hz		
Max. operating current, compressor	A	11.5	11.5	11.5
Cos ϕ		0.92	0.92	0.92
Compressor starting current, inverter controlled	A	< 10	< 10	< 10
Starting current, compressor with stalled armature	A	< 10	< 10	< 10
Fuse protection		B16A	B16A	B16A
IP rating		IP X4	IP X4	IP X4
Indoor unit electrical values				
PCB				
– Rated voltage		1/N/PE 230 V/50 Hz		
– Power supply fuse protection		1 x B16A	1 x B16A	1 x B16A
– Internal fuse protection		6.3 A H (slow)/250 V~		
Instantaneous heating water heater				
– Rated voltage		3/N/PE 400 V/50 Hz		
– Heating output	kW	8	8	8
– Power supply fuse protection		3 x B16A	3 x B16A	3 x B16A
Max. power consumption				
Fan	W	2 x 140	2 x 140	2 x 140
Outdoor unit	kW	4.8	5.4	5.4
Secondary pump (PWM)	W	60	60	60
Control unit/PCB, indoor unit	W	65	65	65
Control unit/PCB power, indoor unit	W	1000	1000	1000



Vitocal 151-A (cont.)

Type AWOT-E-AC		151.A10	151.A13	151.A16
Mobile data transfer				
WiFi				
– Transfer standard		IEEE 802.11 b/g/n	IEEE 802.11 b/g/n	IEEE 802.11 b/g/n
– Frequency range	MHz	2000 to 2483.5	2000 to 2483.5	2000 to 2483.5
– Max. transmission power	dBm	+15	+15	+15
Low power radio				
– Transfer standard		IEEE 802.15.4	IEEE 802.15.4	IEEE 802.15.4
– Frequency range	MHz	2000 to 2483.5	2000 to 2483.5	2000 to 2483.5
– Max. transmission power	dBm	+6	+6	+6
Service link				
– Transfer standard		LTE-CAT-NB1	LTE-CAT-NB1	LTE-CAT-NB1
– Frequency range band 3	MHz	1710 to 1785	1710 to 1785	1710 to 1785
– Frequency range band 8	MHz	880 to 915	880 to 915	880 to 915
– Frequency range band 20	MHz	832 to 862	832 to 862	832 to 862
– Max. transmission power	dBm	+23	+23	+23
Refrigerant circuit				
Refrigerant				
		R290	R290	R290
– Safety group		A3	A3	A3
– Charge weight	kg	2	2	2
– Global warming potential (GWP) ^{*4}		0.02	0.02	0.02
– CO ₂ equivalent	t	0.00004	0.00004	0.00004
Compressor (hermetically sealed)	Type	Twin rotary	Twin rotary	Twin rotary
– Oil in compressor	Type	HAF68	HAF68	HAF68
– Oil volume in compressor	l	1.150 ±0.020	1.150 ±0.020	1.150 ±0.020
Permissible operating pressure				
– High pressure side	bar	30.3	30.3	30.3
	MPa	3.03	3.03	3.03
– Low pressure side	bar	30.3	30.3	30.3
	MPa	3.03	3.03	3.03
Integral DHW cylinder				
Capacity	l	190	190	190
Outdoor unit dimensions				
Total length	mm	600	600	600
Total width	mm	1144	1144	1144
Total height	mm	1382	1382	1382
Indoor unit dimensions				
Total length	mm	597	597	597
Total width	mm	600	600	600
Total height	mm	1900	1900	1900
Total weight				
Indoor unit with 1 integrated heating/cooling circuit				
– Empty	kg	170	170	170
– With filled buffer cylinder	kg	386	386	386
Outdoor unit	kg	197	197	197
Permissible operating pressure, secondary side				
	bar	3	3	3
	MPa	0.3	0.3	0.3
Connections with connection pipes supplied				
Heating water flow/return, heating circuits or heating water buffer cylinder	mm	Cu 28 x 1.0	Cu 28 x 1.0	Cu 28 x 1.0
Heating water flow/return, DHW cylinder	mm	Cu 22 x 1.0	Cu 22 x 1.0	Cu 22 x 1.0
Outdoor unit heating water flow/return	mm	Cu 28 x 1.0	Cu 28 x 1.0	Cu 28 x 1.0
Length of connection line indoor — outdoor unit (hydraulic connection set)				
	m	5 to 20	5 to 20	5 to 20
Sound power of the outdoor unit at rated heating output (Measurements with reference to EN 12102/EN ISO 9614-2)				
Assessed total sound power level at A7/W55				
– ErP	dB(A)	56	56	56
– Max.	dB(A)	66	66	66
– In night mode	dB(A)	59	59	59
Energy efficiency class to Commission Regulation (EU) No. 813/2013				
Heating, average climatic conditions				
– Low temperature application (W35)		A+++	A+++	A+++
– Medium temperature application (W55)		A++	A++	A++

Vitocal 151-A (cont.)

Type AWOT-E-AC	151.A10	151.A13	151.A16
Heating performance data to Commission Regulation (EU) No. 813/2013 (average climatic conditions)			
Low temperature application (W35)			
– Energy efficiency η_s	%	190	178
– Rated heating output P_{rated}	kW	9.8	12.4
– Seasonal coefficient of performance (SCOP)		4.825	4.525
Medium temperature application (W55)			
– Energy efficiency η_s	%	145	141
– Rated heating output P_{rated}	kW	9.37	12.1
– Seasonal coefficient of performance (SCOP)		3.7	3.6
Heat pumps with 230 V~ outdoor unit			
Type AWOT-M-E-AC	151.A10	151.A13	151.A16
Heating performance data to EN 14511 (A2/W35)			
Rated heating output	kW	5.8	6.7
Power consumption	kW	1.41	1.76
Coefficient of performance ϵ (COP) in heating mode		4.1	3.8
Output control	kW	2.2 to 11.0	2.6 to 12.3
Heating performance data to EN 14511 (A7/W35, 5 K spread)			
Rated heating output	kW	7.3	8.1
Fan speed	rpm	430	440
Air flow rate	m ³ /h	4045	4188
Power consumption	kW	1.46	1.65
Coefficient of performance ϵ (COP) in heating mode		5.0	4.9
Output control	kW	2.6 to 12.0	3.0 to 13.4
Heating performance data to EN 14511 (A–7/W35)			
Rated heating output	kW	9.7	11.1
Power consumption	kW	3.23	3.96
Coefficient of performance ϵ (COP) in heating mode		3.0	2.8
Air intake temperature			
Cooling mode			
– Min.	°C	10	10
– Max.	°C	45	45
Heating mode			
– Min.	°C	–20	–20
– Max.	°C	40	40
Heating water (secondary circuit)			
Capacity excl. expansion vessel	l	18	18
Heat pump circuit minimum flow rate (defrosting)	l/h	1000	1000
Max. flow temperature	°C	70	70
Outdoor unit electrical values			
Rated voltage, compressor		1/N/PE 230 V/50 Hz	
Max. operating current, compressor	A	21	23
Cos ϕ		0.92	0.92
Compressor starting current, inverter controlled	A	< 10	< 10
Starting current, compressor with stalled armature	A	< 10	< 10
Fuse protection	A	B25A	B25A
IP rating		IP X4	IP X4
Indoor unit electrical values			
PCB			
– Rated voltage		1/N/PE 230 V/50 Hz	
– Power supply fuse protection		1 x B16A	1 x B16A
– Internal fuse protection		6.3 A H (slow)/250 V~	
Instantaneous heating water heater			
– Rated voltage		3/N/PE 400 V/50 Hz	
– Heating output	kW	8	8
– Power supply fuse protection		3 x B16A	3 x B16A
Max. power consumption			
Fan	W	2 x 140	2 x 140
Outdoor unit	kW	4.8	5.4
Secondary pump (PWM)	W	60	60
Control unit/PCB, indoor unit	W	65	65
Control unit/PCB power, indoor unit	W	1000	1000

Vitocal 151-A (cont.)

Type AWOT-M-E-AC		151.A10	151.A13	151.A16
Mobile data transfer				
WiFi				
– Transfer standard		IEEE 802.11 b/g/n	IEEE 802.11 b/g/n	IEEE 802.11 b/g/n
– Frequency range	MHz	2000 to 2483.5	2000 to 2483.5	2000 to 2483.5
– Max. transmission power	dBm	+15	+15	+15
Low power radio				
– Transfer standard		IEEE 802.15.4	IEEE 802.15.4	IEEE 802.15.4
– Frequency range	MHz	2000 to 2483.5	2000 to 2483.5	2000 to 2483.5
– Max. transmission power	dBm	+6	+6	+6
Service link				
– Transfer standard		LTE-CAT-NB1	LTE-CAT-NB1	LTE-CAT-NB1
– Frequency range band 3	MHz	1710 to 1785	1710 to 1785	1710 to 1785
– Frequency range band 8	MHz	880 to 915	880 to 915	880 to 915
– Frequency range band 20	MHz	832 to 862	832 to 862	832 to 862
– Max. transmission power	dBm	+23	+23	+23
Refrigerant circuit				
Refrigerant				
		R290	R290	R290
– Safety group		A3	A3	A3
– Charge weight	kg	2	2	2
– Global warming potential (GWP) ^{*5}		0.02	0.02	0.02
– CO ₂ equivalent	t	0.00004	0.00004	0.00004
Compressor (hermetically sealed)	Type	Twin rotary	Twin rotary	Twin rotary
– Oil in compressor	Type	HAF68	HAF68	HAF68
– Oil volume in compressor	l	1.150 ±0.020	1.150 ±0.020	1.150 ±0.020
Permissible operating pressure				
– High pressure side	bar	30.3	30.3	30.3
	MPa	3.03	3.03	3.03
– Low pressure side	bar	30.3	30.3	30.3
	MPa	3.03	3.03	3.03
Integral DHW cylinder				
Capacity	l	190	190	190
Outdoor unit dimensions				
Total length	mm	600	600	600
Total width	mm	1144	1144	1144
Total height	mm	1382	1382	1382
Indoor unit dimensions				
Total length	mm	597	597	597
Total width				
– With 1 integrated heating/cooling circuit	mm	600	600	600
Total height	mm	1900	1900	1900
Total weight				
Indoor unit with 1 integrated heating/cooling circuit				
– Empty	kg	170	170	170
– With filled buffer cylinder	kg	386	386	386
Outdoor unit	kg	191	191	191
Permissible operating pressure, secondary side				
	bar	3	3	3
	MPa	0.3	0.3	0.3
Connections with connection pipes supplied				
Heating water flow/return, heating circuits or heating water buffer cylinder	mm	Cu 28 x 1.0	Cu 28 x 1.0	Cu 28 x 1.0
Heating water flow/return, DHW cylinder	mm	Cu 22 x 1.0	Cu 22 x 1.0	Cu 22 x 1.0
Outdoor unit heating water flow/return	mm	Cu 28 x 1.0	Cu 28 x 1.0	Cu 28 x 1.0
Length of connection line indoor — outdoor unit (hydraulic connection set)				
	m	5 to 20	5 to 20	5 to 20
Sound power of the outdoor unit at rated heating output (Measurements with reference to EN 12102/EN ISO 9614-2)				
Assessed total sound power level at A7/W55				
– ErP	dB(A)	56	56	56
– Max.	dB(A)	66	66	66
– In night mode	dB(A)	59	59	59
Energy efficiency class to Commission Regulation (EU) No. 813/2013				
Heating, average climatic conditions				
– Low temperature application (W35)		A+++	A+++	A+++
– Medium temperature application (W55)		A++	A++	A++

Vitocal 151-A (cont.)

Type AWOT-M-E-AC	151.A10	151.A13	151.A16
Heating performance data to Commission Regulation (EU) No. 813/2013 (average climatic conditions)			
Low temperature application (W35)			
– Energy efficiency η_s	%	190	178
– Rated heating output P_{rated}	kW	9.8	12.4
– Seasonal coefficient of performance (SCOP)		4.825	4.525
Medium temperature application (W55)			
– Energy efficiency η_s	%	145	141
– Rated heating output P_{rated}	kW	9.37	12.1
– Seasonal coefficient of performance (SCOP)		3.7	3.6

Heat pumps with 230 V~ outdoor unit

Type AWOT-M-E-AC	151.A10 SP	151.A13 SP	151.A16 SP
Heating performance data to EN 14511 (A2/W35)			
Rated heating output	kW	5.8	6.7
Power consumption	kW	1.41	1.76
Coefficient of performance ϵ (COP) in heating mode (tolerance $\pm 5\%$)		4.1	3.8
Output control	kW	2.2 to 11.0	2.6 to 12.3
Heating performance data to EN 14511 (A7/W35, 5 K spread)			
Rated heating output	kW	7.3	8.1
Fan speed	rpm	430	440
Air flow rate	m ³ /h	4045	4188
Power consumption	kW	1.46	1.65
Coefficient of performance ϵ (COP) in heating mode (tolerance $\pm 5\%$)		5.0	4.9
Output control	kW	2.6 to 12.0	3.0 to 13.4
Heating performance data to EN 14511 (A–7/W35)			
Rated heating output	kW	9.7	11.1
Power consumption	kW	3.23	3.96
Coefficient of performance ϵ (COP) in heating mode		3.0	2.8
Air intake temperature			
Cooling mode			
– Min.	°C	10	10
– Max.	°C	45	45
Heating mode			
– Min.	°C	–20	–20
– Max.	°C	40	40
Heating water (secondary circuit)			
Capacity excl. expansion vessel	l	18	18
Heat pump circuit minimum flow rate	l/h	1000	1000
Max. flow temperature	°C	70	70
Outdoor unit electrical values			
Rated voltage, compressor		1/N/PE 230 V/50 Hz	
Max. operating current, compressor	A	21	23
Cos ϕ		0.92	0.92
Compressor starting current, inverter controlled	A	< 10	< 10
Starting current, compressor with stalled armature	A	< 10	< 10
Fuse protection	A	B25A	B25A
IP rating		IP X4	IP X4
Indoor unit electrical values			
PCB			
– Rated voltage		1/N/PE 230 V/50 Hz	
– Internal fuse protection		6.3 A H (slow)/250 V~	
Instantaneous heating water heater			
– Heating output	kW	4.8	4.8
Power supply, indoor unit			
– Rated voltage		1/N/PE 230 V/50 Hz	
– Power supply fuse protection		1 x B32A	1 x B32A
Max. power consumption			
Fan	W	2 x 140	2 x 140
Outdoor unit	kW	4.8	5.4
Secondary pump (PWM)	W	60	60
Control unit/PCB, indoor unit	W	65	65
Control unit/PCB power, indoor unit	W	1000	1000

Vitocal 151-A (cont.)

Type AWOT-M-E-AC	151.A10 SP	151.A13 SP	151.A16 SP
Mobile data transfer			
WiFi			
– Transfer standard	IEEE 802.11 b/g/n	IEEE 802.11 b/g/n	IEEE 802.11 b/g/n
– Frequency range MHz	2000 to 2483.5	2000 to 2483.5	2000 to 2483.5
– Max. transmission power dBm	+15	+15	+15
Low power radio			
– Transfer standard	IEEE 802.15.4	IEEE 802.15.4	IEEE 802.15.4
– Frequency range MHz	2000 to 2483.5	2000 to 2483.5	2000 to 2483.5
– Max. transmission power dBm	+6	+6	+6
Service link			
– Transfer standard	LTE-CAT-NB1	LTE-CAT-NB1	LTE-CAT-NB1
– Frequency range band 3 MHz	1710 to 1785	1710 to 1785	1710 to 1785
– Frequency range band 8 MHz	880 to 915	880 to 915	880 to 915
– Frequency range band 20 MHz	832 to 862	832 to 862	832 to 862
– Max. transmission power dBm	+23	+23	+23
Refrigerant circuit			
Refrigerant			
– Safety group	R290 A3	R290 A3	R290 A3
– Charge weight kg	2	2	2
– Global warming potential (GWP)* ⁶	0.02	0.02	0.02
– CO ₂ equivalent t	0.00004	0.00004	0.00004
Compressor (hermetically sealed)			
– Oil in compressor Type	Twin rotary	Twin rotary	Twin rotary
– Oil volume in compressor l	HAF68 1.150 ±0.020	HAF68 1.150 ±0.020	HAF68 1.150 ±0.020
Permissible operating pressure			
– High pressure side bar	30.3	30.3	30.3
MPa	3.03	3.03	3.03
– Low pressure side bar	30.3	30.3	30.3
MPa	3.03	3.03	3.03
Integral DHW cylinder			
Capacity l	190	190	190
Outdoor unit dimensions			
Total length mm	600	600	600
Total width mm	1144	1144	1144
Total height mm	1382	1382	1382
Indoor unit dimensions			
Total length mm	597	597	597
Total width mm	600	600	600
Total height mm	1900	1900	1900
Total weight			
Indoor unit with 1 integrated heating/cooling circuit			
– Empty kg	170	170	170
– With filled buffer cylinder kg	386	386	386
Outdoor unit kg	191	191	191
Permissible operating pressure, secondary side			
bar	3	3	3
MPa	0.3	0.3	0.3
Connections with connection pipes supplied			
Heating water flow/return, heating circuits or heating water buffer cylinder mm	Cu 28 x 1.0	Cu 28 x 1.0	Cu 28 x 1.0
Heating water flow/return, DHW cylinder mm	Cu 22 x 1.0	Cu 22 x 1.0	Cu 22 x 1.0
Outdoor unit heating water flow/return mm	Cu 28 x 1.0	Cu 28 x 1.0	Cu 28 x 1.0
Length of connection line indoor — outdoor unit (hydraulic connection set)			
m	5 to 20	5 to 20	5 to 20
Sound power of the outdoor unit at rated heating output (Measurements with reference to EN 12102/EN ISO 9614-2)			
Assessed total sound power level at A7/W55			
– ErP dB(A)	56	56	56
– Max. dB(A)	66	66	66
– In night mode dB(A)	59	59	59
Energy efficiency class to Commission Regulation (EU) No. 813/2013			
Heating, average climatic conditions			
– Low temperature application (W35)	A+++	A+++	A+++
– Medium temperature application (W55)	A+++	A++	A++

Vitocal 151-A (cont.)

Type AWOT-M-E-AC	151.A10 SP	151.A13 SP	151.A16 SP
Heating performance data to Commission Regulation (EU) No. 813/2013 (average climatic conditions)			
Low temperature application (W35)			
– Energy efficiency η_s	%	190	178
– Rated heating output P_{rated}	kW	9.8	12.4
– Seasonal coefficient of performance (SCOP)		4.825	4.525
Medium temperature application (W55)			
– Energy efficiency η_s	%	145	141
– Rated heating output P_{rated}	kW	9.37	12.1
– Seasonal coefficient of performance (SCOP)		3.7	3.6

Dimensions – indoor unit

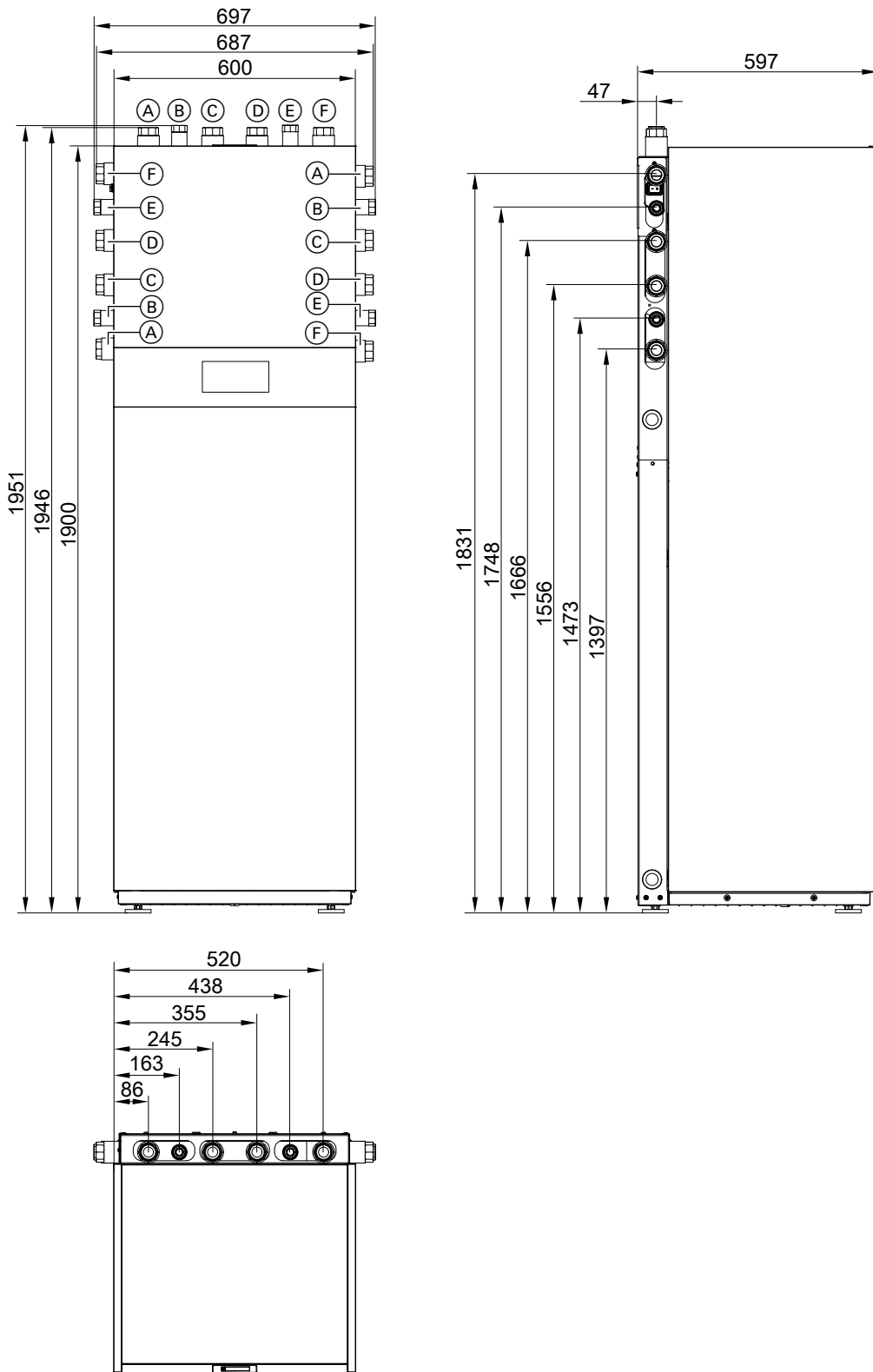

- (A) Secondary circuit flow (heating/cooling circuit 1 / heating water buffer cylinder), connection Cu 28 x 1.0 mm
- (B) Cold water, connection Cu 22 x 1.0 mm
- (C) Outdoor unit flow (indoor unit heating water inlet), connection Cu 28 x 1.0 mm
- (D) Outdoor unit return (indoor unit heating water outlet), connection Cu 28 x 1.0 mm
- (E) DHW, connection Cu 22 x 1.0 mm
- (F) Secondary circuit return (heating/cooling circuit 1/heating water buffer cylinder), connection Cu 28 x 1.0 mm

6179959

Outdoor unit dimensions

See page 28 onwards.

Application limits to EN 14511

Heating

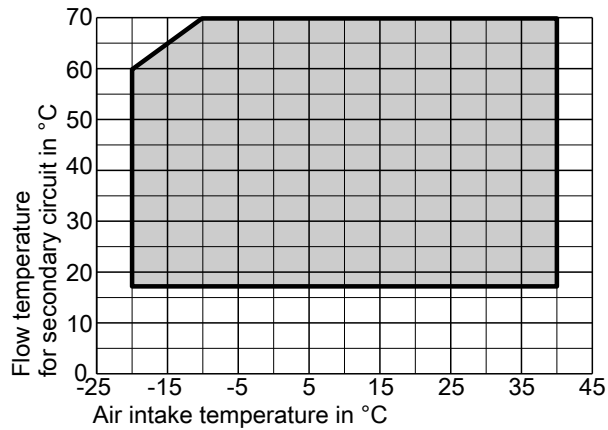

Cooling

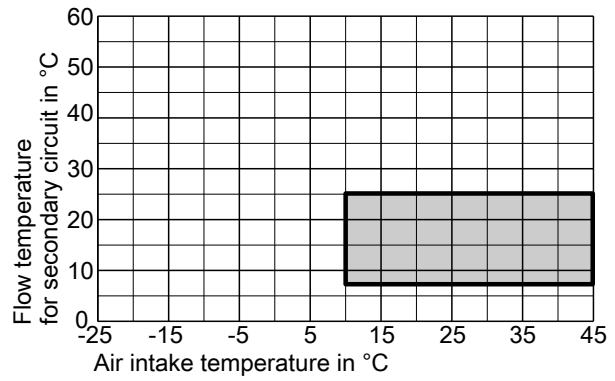

Residual heads of integral circulation pump

Residual heads of the integral circulation pump

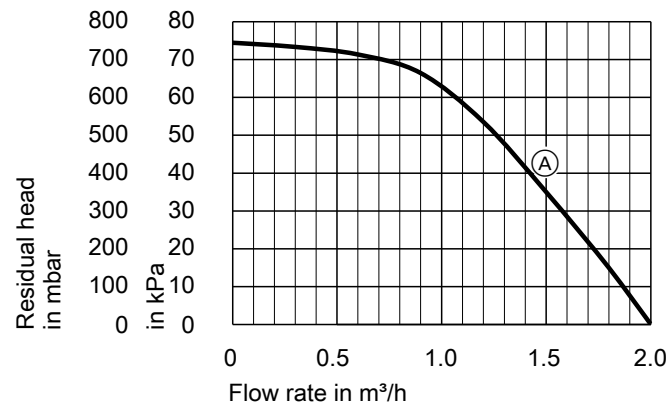

(A) Secondary pump/circulation pump for heating/cooling circuit 1

3

Outdoor unit

4.1 Product description

Benefits



- Ⓐ Power saving variable speed EC fan
- Ⓑ Coated evaporator with corrugated fins for higher efficiency
- Ⓒ Safety valve
- Ⓓ Condenser
- Ⓔ Inverter
- Ⓕ Suction gas cooler inverter
- Ⓖ 4-way diverter valve
- Ⓗ Hermetically sealed twin rotary compressor with output-dependent control

Outdoor unit (cont.)

Dimensions

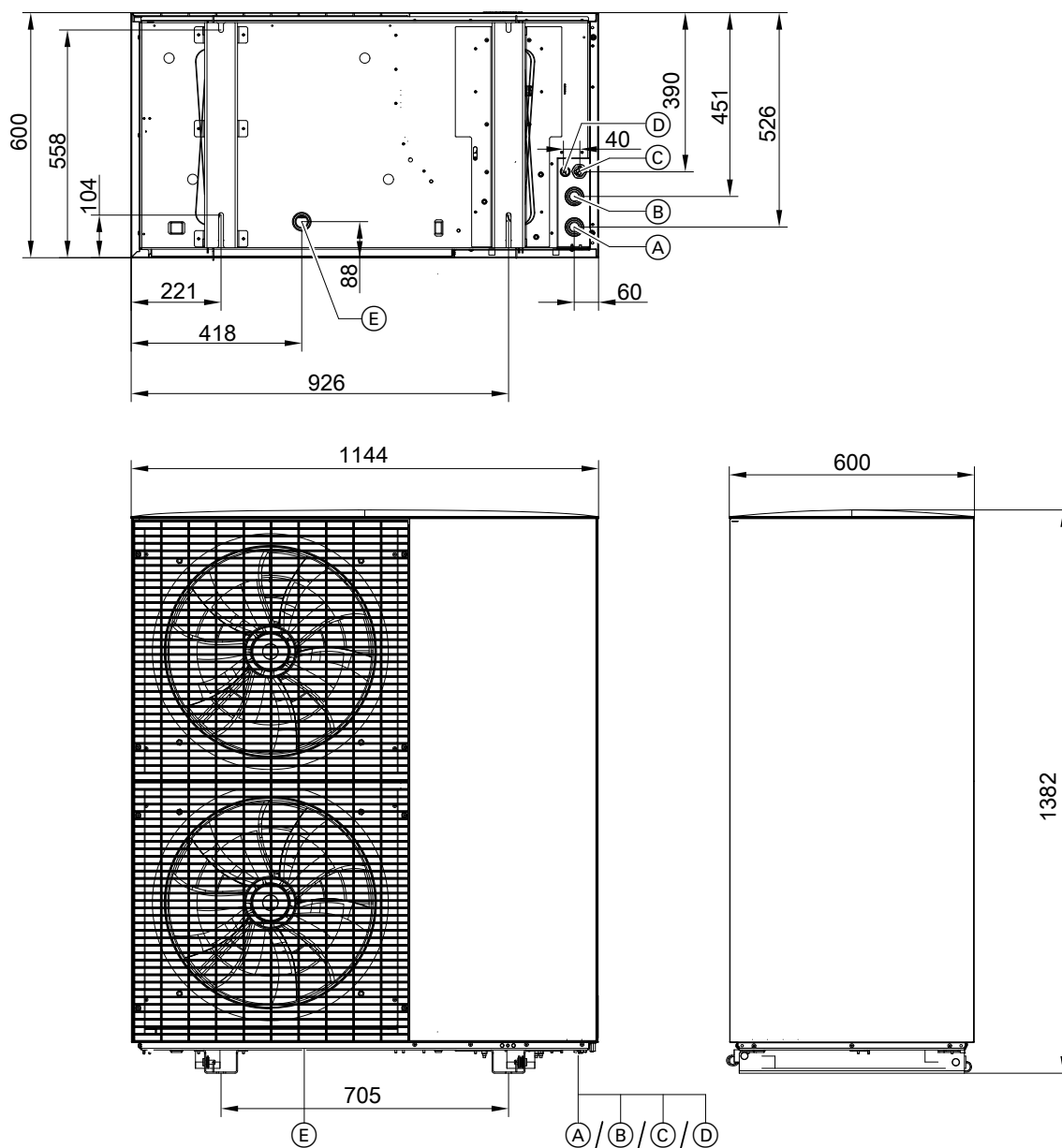

- (A) Outdoor unit flow (heating water outlet): Plug-in connection for Cu 28 x 1.0 mm
- (B) Outdoor unit return (heating water inlet): Plug-in connection for Cu 28 x 1.0 mm
- (C) Power cable plug
- (D) CAN bus communication cable plug (accessories)
- (E) Condensate drain

Curves

5.1 Performance graph, outdoor unit type 151.A10, 230 V~

Heating

Heating output at flow temperatures of 35 °C, 45 °C, 55 °C, 65 °C, 70 °C

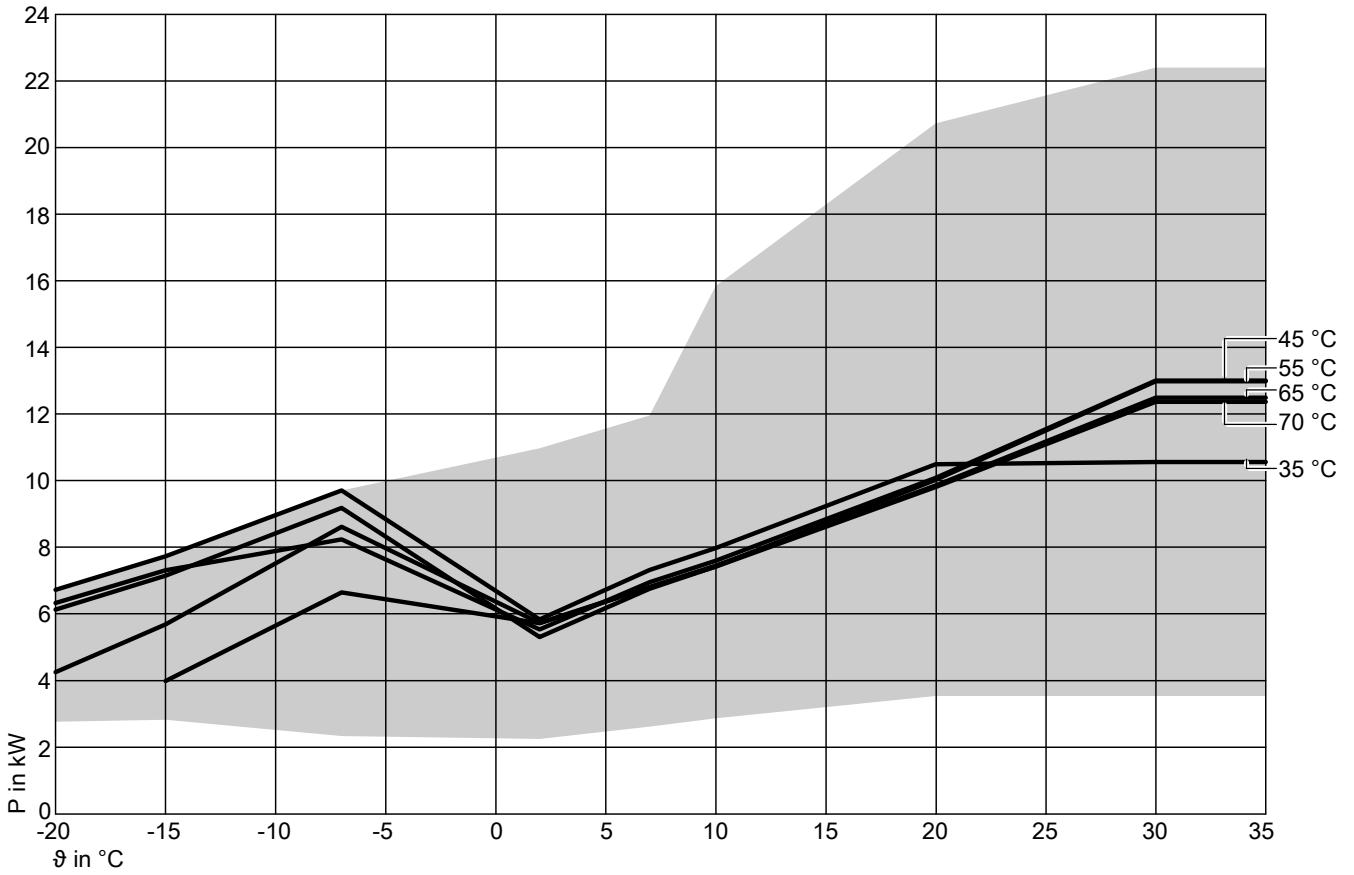

Possible output range

Power consumption for heating at flow temperatures of 35 °C, 45 °C, 55 °C, 65 °C, 70 °C

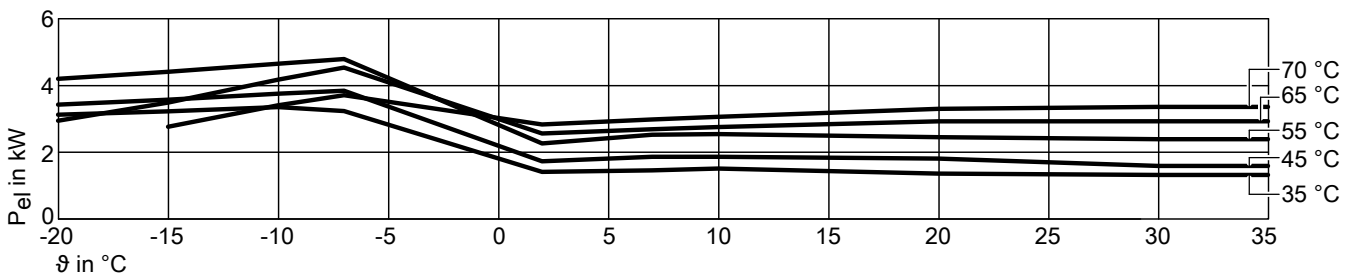

Curves (cont.)

Coefficient of performance (COP) at flow temperatures of 35 °C, 45 °C, 55 °C, 65 °C, 70 °C

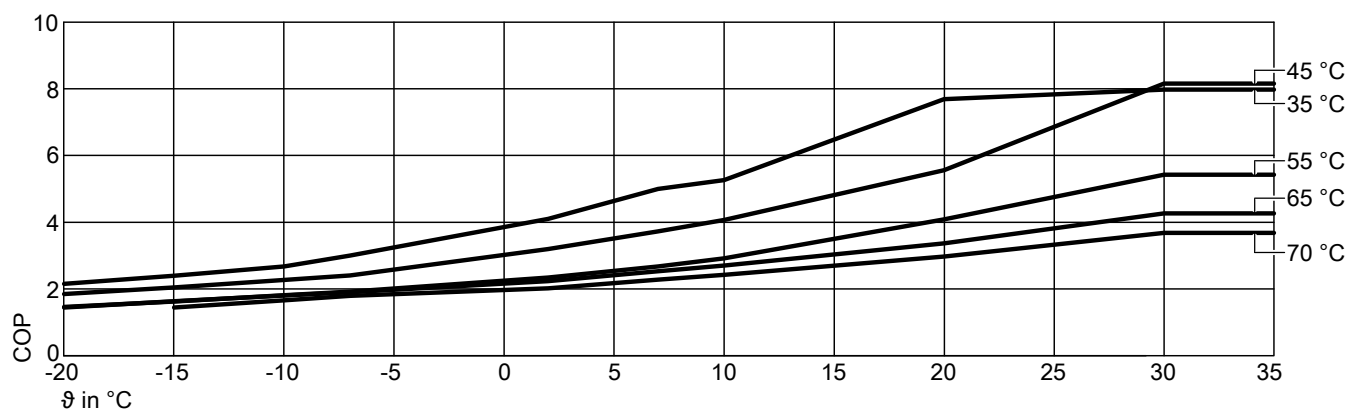

θ Air intake temperature
P Heating output
P_{el} Power consumption
COP Performance factor

Note

- The COP data in the tables and graphs was calculated with reference to EN 14511.
- Performance characteristics apply to new appliances with clean plate heat exchangers.

Operating point	W A	°C °C	35									
			-20	-15	-10	-7	2	7	10	20	30	35
Max. heating output		kW	6.72	7.72	8.96	9.70	10.97	11.95	15.84	20.73	22.40	22.40
Rated heating output		kW	6.72	7.72	8.96	9.70	5.80	7.30	7.97	10.49	10.56	10.56
Power consumption		kW	3.12	3.22	3.35	3.23	1.41	1.46	1.51	1.36	1.32	1.32
Coefficient of performance ε (COP)			2.15	2.39	2.67	3.00	4.10	5.00	5.27	7.70	7.98	7.98
Min. heating output		kW	2.75	2.81	2.51	2.32	2.24	2.61	2.86	3.53	3.53	3.53

Operating point	W A	°C °C	45									
			-20	-15	-10	-7	2	7	10	20	30	35
Max. heating output		kW	6.32	7.30	7.88	8.23	9.86	10.72	13.22	20.24	22.96	23.19
Rated heating output		kW	6.32	7.30	7.88	8.23	5.53	6.95	7.59	10.08	13.00	13.00
Power consumption		kW	3.43	3.57	3.47	3.42	1.73	1.87	1.87	1.81	1.59	1.59
Coefficient of performance ε (COP)			1.85	2.04	2.27	2.40	3.20	3.73	4.07	5.56	8.16	8.16
Min. heating output		kW	2.5	2.55	2.26	2.09	2.00	2.34	2.57	3.49	4.32	4.32

Operating point	W A	°C °C	55									
			-20	-15	-10	-7	2	7	10	20	30	35
Max. heating output		kW	6.12	7.14	8.41	9.18	10.86	11.86	15.16	19.69	21.88	22.16
Rated heating output		kW	6.12	7.14	8.41	9.18	5.30	6.75	7.42	10.02	12.98	12.98
Power consumption		kW	4.20	4.41	4.65	4.79	2.26	2.53	2.54	2.45	2.39	2.39
Coefficient of performance ε (COP)			1.46	1.62	1.81	1.92	2.34	2.67	2.92	4.09	5.43	5.43
Min. heating output		kW	2.30	2.35	2.08	1.93	2.64	3.12	3.44	4.68	5.62	5.62

Operating point	W A	°C °C	65									
			-20	-15	-10	-7	2	7	10	20	30	35
Max. heating output		kW	4.24	5.68	7.51	8.61	10.87	11.84	14.84	18.25	21.03	21.03
Rated heating output		kW	4.24	5.68	7.51	8.61	5.72	6.80	7.44	9.85	12.49	12.49
Power consumption		kW	2.94	3.49	4.17	4.53	2.56	2.69	2.76	2.93	2.93	2.93
Coefficient of performance ε (COP)			1.44	1.63	1.80	1.90	2.23	2.53	2.70	3.37	4.27	4.27
Min. heating output		kW	2.20	2.24	2.42	2.52	3.50	4.23	4.69	6.48	8.05	8.05

Operating point	W A	°C °C	70									
			-20	-15	-10	-7	2	7	10	20	30	35
Max. heating output		kW			5.64	6.64	9.33	10.78	13.76	16.83	20.74	20.78
Rated heating output		kW			5.64	6.64	5.71	6.79	7.41	9.80	12.36	12.36
Power consumption		kW			3.41	3.71	2.83	2.98	3.06	3.30	3.36	3.36
Coefficient of performance ε (COP)					1.66	1.79	2.02	2.28	2.42	2.97	3.68	3.68
Min. heating output		kW			2.75	3.05	4.22	5.01	5.55	7.57	9.08	9.08

Curves (cont.)

Cooling

Cooling capacity at flow temperature of 18 °C

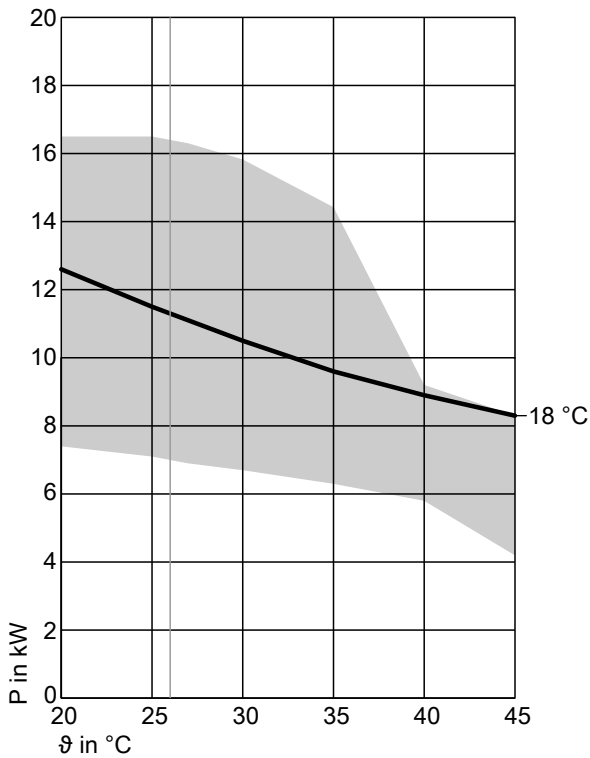

Possible output range

Power consumption for cooling at flow temperature of 18 °C

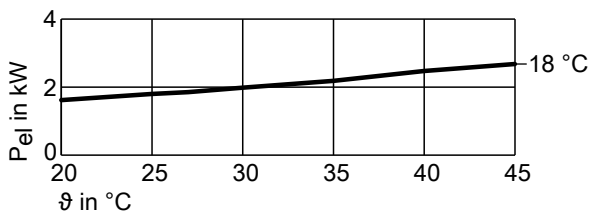

Energy efficiency ratio (EER) at flow temperature of 18 °C

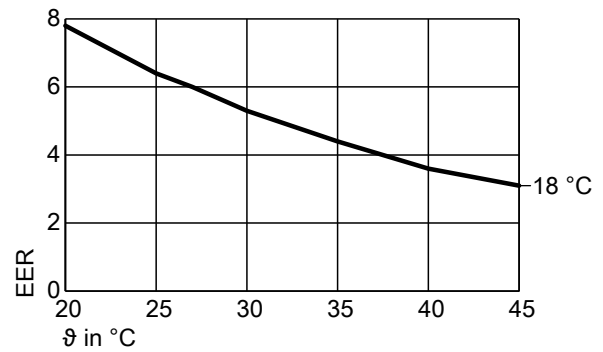

ϑ Air intake temperature
P Cooling capacity
P_{el} Power consumption
EER Performance factor

Note

- The EER data in the tables and graphs was calculated with reference to EN 14511.
- Performance characteristics apply to new appliances with clean plate heat exchangers.

Operating point	W A	°C °C	18						
			20	25	27	30	35	40	45
Max. cooling capacity		kW	16.50	16.50	16.30	15.80	14.40	9.30	8.30
Cooling capacity		kW	12.60	11.50	11.10	10.50	9.60	8.90	8.30
Power consumption		kW	1.62	1.80	1.85	1.98	2.18	2.47	2.68
Energy efficiency ratio EER			7.80	6.40	6.00	5.30	4.40	3.60	3.10
Min. cooling capacity		kW	7.40	7.10	6.90	6.70	6.30	5.80	4.20

5.2 Performance graph, outdoor unit type 151.A10, 400 V~

Heating

Heating output at flow temperatures of 35 °C, 45 °C, 55 °C, 65 °C, 70 °C

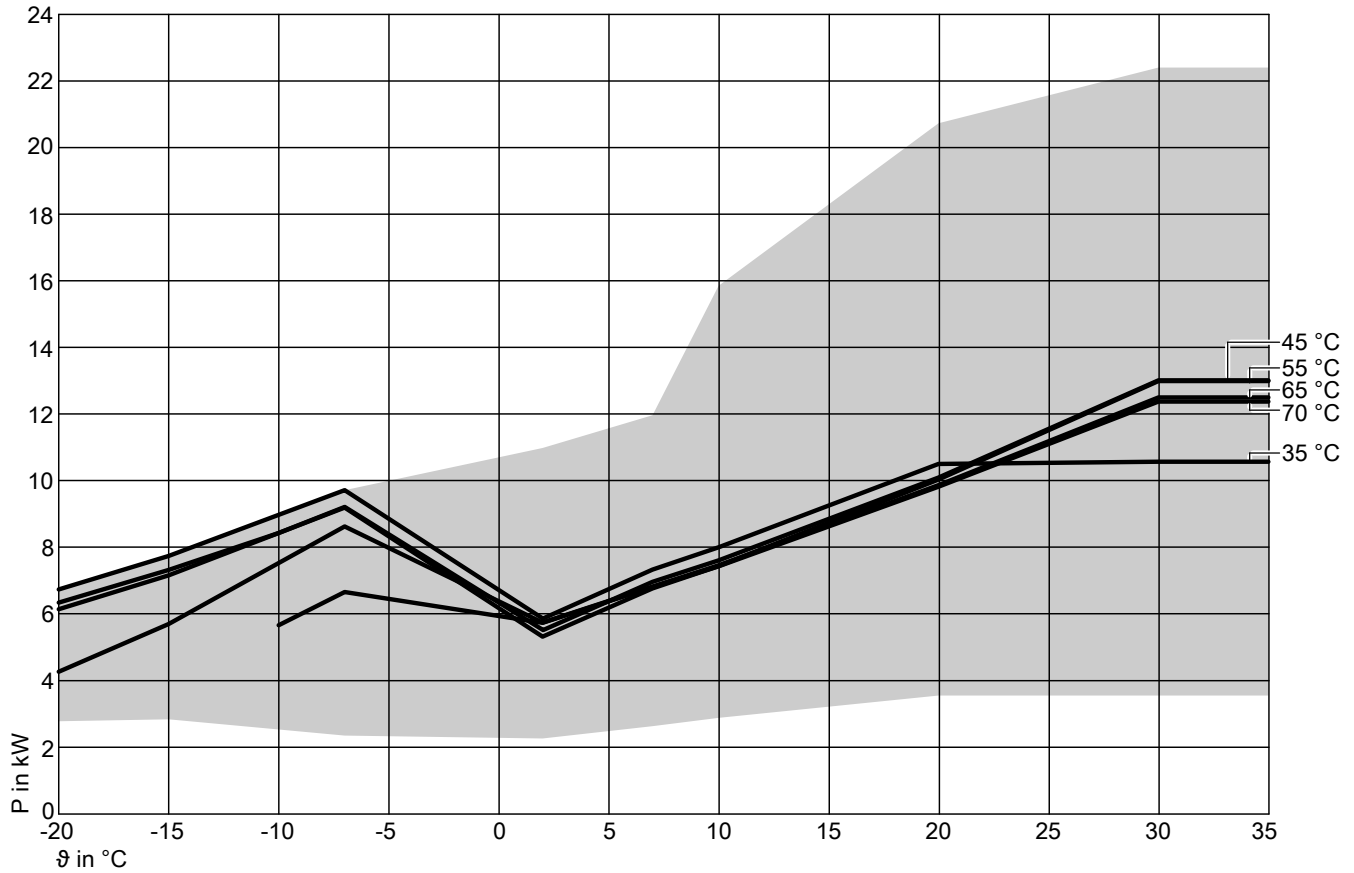

Possible output range

Power consumption for heating at flow temperatures of 35 °C, 45 °C, 55 °C, 65 °C, 70 °C

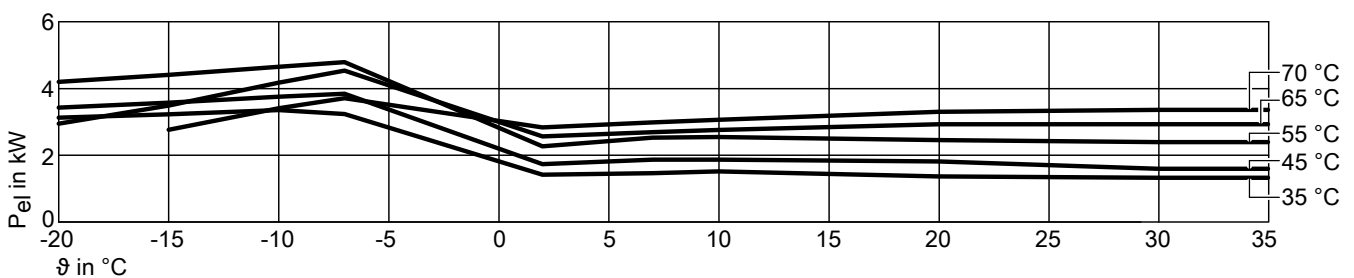

Curves (cont.)

Coefficient of performance (COP) at flow temperatures of 35 °C, 45 °C, 55 °C, 65 °C, 70 °C

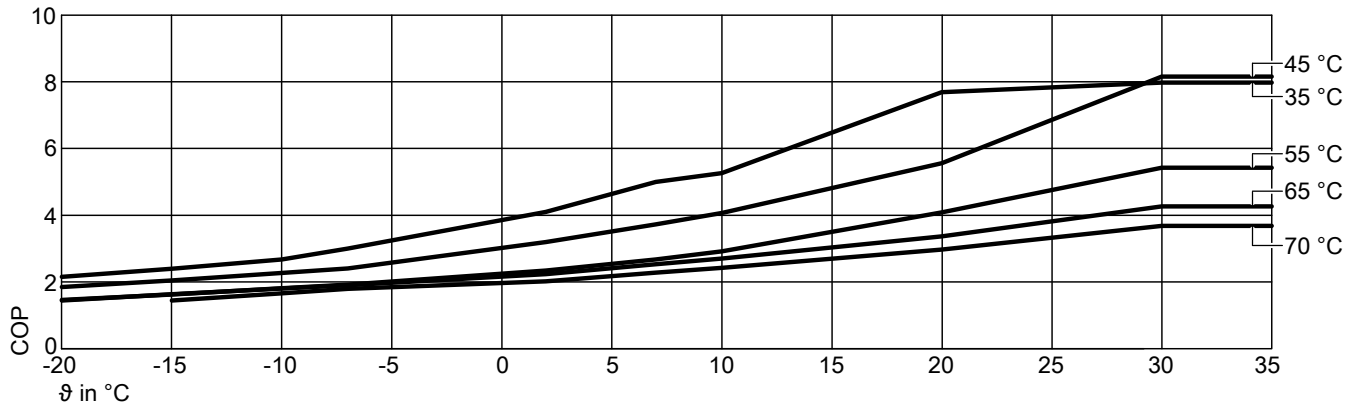

ϑ Air intake temperature
P Heating output
P_{el} Power consumption
COP Performance factor

Note

- The COP data in the tables and graphs was calculated with reference to EN 14511.
- Performance characteristics apply to new appliances with clean plate heat exchangers.

Operating point	W A	°C °C	35									
			-20	-15	-10	-7	2	7	10	20	30	35
Max. heating output		kW	6.72	7.72	8.96	9.70	10.97	11.95	15.84	20.73	23.40	23.40
Rated heating output		kW	6.72	7.72	8.96	9.70	5.80	7.30	7.97	10.49	10.56	10.56
Power consumption		kW	3.12	3.22	3.35	3.23	1.41	1.46	1.51	1.36	1.32	1.32
Coefficient of performance ε (COP)			2.15	2.39	2.67	3.00	4.10	5.00	5.27	7.70	7.98	7.98
Min. heating output		kW	2.75	2.81	2.51	2.32	2.24	2.61	2.86	3.53	3.53	3.53

Operating point	W A	°C °C	45									
			-20	-15	-10	-7	2	7	10	20	30	35
Max. heating output		kW	6.32	7.30	8.51	9.23	10.86	11.72	13.02	20.24	22.96	23.19
Rated heating output		kW	6.32	7.30	8.51	9.23	5.53	6.95	7.59	10.08	13.00	13.00
Power consumption		kW	3.43	3.57	3.75	3.84	1.73	1.87	1.87	1.81	1.59	1.59
Coefficient of performance ε (COP)			1.85	2.04	2.27	2.40	3.20	3.73	4.07	5.56	8.16	8.16
Min. heating output		kW	2.50	2.55	2.26	2.09	2.00	2.34	2.57	3.49	4.32	4.32

Operating point	W A	°C °C	55									
			-20	-15	-10	-7	2	7	10	20	30	35
Max. heating output		kW	6.12	7.14	8.41	9.18	10.86	11.86	15.16	19.69	21.88	22.16
Rated heating output		kW	6.12	7.14	8.41	9.18	5.30	6.75	7.42	10.02	12.98	12.98
Power consumption		kW	4.20	4.41	4.65	4.79	2.26	2.53	2.54	2.45	2.39	2.39
Coefficient of performance ε (COP)			1.46	1.62	1.81	1.92	2.34	2.67	2.92	4.09	5.43	5.43
Min. heating output		kW	2.30	2.35	2.08	1.93	2.64	3.12	3.44	4.68	5.62	5.62

Operating point	W A	°C °C	65									
			-20	-15	-10	-7	2	7	10	20	30	35
Max. heating output		kW	4.24	5.68	7.51	8.61	10.87	11.84	14.84	18.25	21.03	21.03
Rated heating output		kW	4.24	5.68	7.51	8.61	5.72	6.80	7.44	9.85	12.49	12.49
Power consumption		kW	2.94	3.49	4.17	4.53	2.56	2.69	2.76	2.93	2.93	2.93
Coefficient of performance ε (COP)			1.44	1.63	1.80	1.90	2.23	2.53	2.70	3.37	4.27	4.27
Min. heating output		kW	2.20	2.24	2.42	2.52	3.50	4.23	4.69	6.48	8.05	8.05

Operating point	W A	°C °C	70									
			-20	-15	-10	-7	2	7	10	20	30	35
Max. heating output		kW			5.64	6.64	8.83	10.78	13.76	16.83	20.74	20.78
Rated heating output		kW			5.64	6.64	5.71	6.79	7.41	9.80	12.36	12.36
Power consumption		kW			3.41	3.71	2.83	2.98	3.06	3.30	3.36	3.36
Coefficient of performance ε (COP)					1.66	1.79	2.02	2.28	2.42	2.97	3.68	3.68
Min. heating output		kW			2.75	3.05	4.22	5.01	5.55	7.57	9.08	9.08

Curves (cont.)

Cooling

Cooling capacity at flow temperature of 18 °C

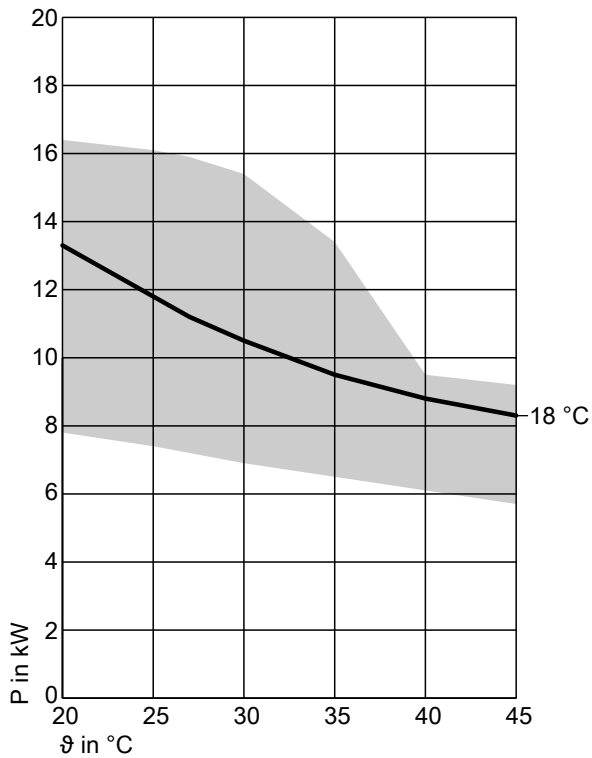

Energy efficiency ratio (EER) at flow temperature of 18 °C

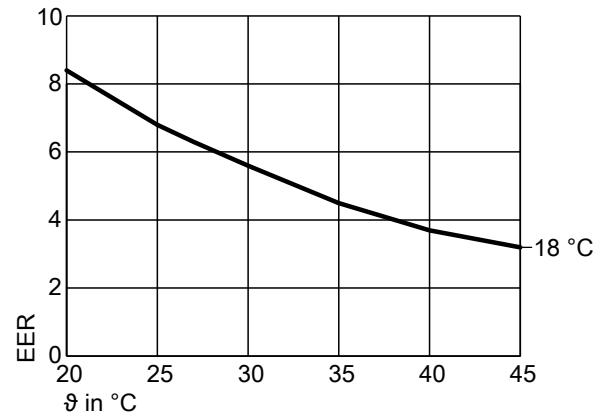

ϑ Air intake temperature
 P Cooling capacity
 P_{el} Power consumption
 EER Performance factor

Note

- The EER data in the tables and graphs was calculated with reference to EN 14511.
- Performance characteristics apply to new appliances with clean plate heat exchangers.

Possible output range

Power consumption for cooling at flow temperature of 18 °C

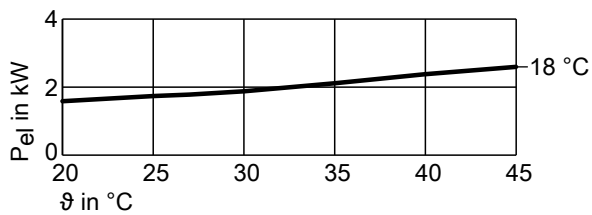

Operating point	W A	°C °C	18						
			20	25	27	30	35	40	45
Max. cooling capacity		kW	16.40	16.10	15.90	15.40	13.40	9.50	9.20
Cooling capacity		kW	13.30	11.80	11.20	10.50	9.50	8.80	8.30
Power consumption		kW	1.58	1.74	1.78	1.88	2.11	2.38	2.59
Energy efficiency ratio EER			8.40	6.80	6.30	5.60	4.50	3.70	3.20
Min. cooling capacity		kW	7.80	7.40	7.20	6.90	6.50	6.10	5.70

5.3 Performance graph, outdoor unit type 151.A13, 230 V~

Heating

Heating output at flow temperatures of 35 °C, 45 °C, 55 °C, 65 °C, 70 °C

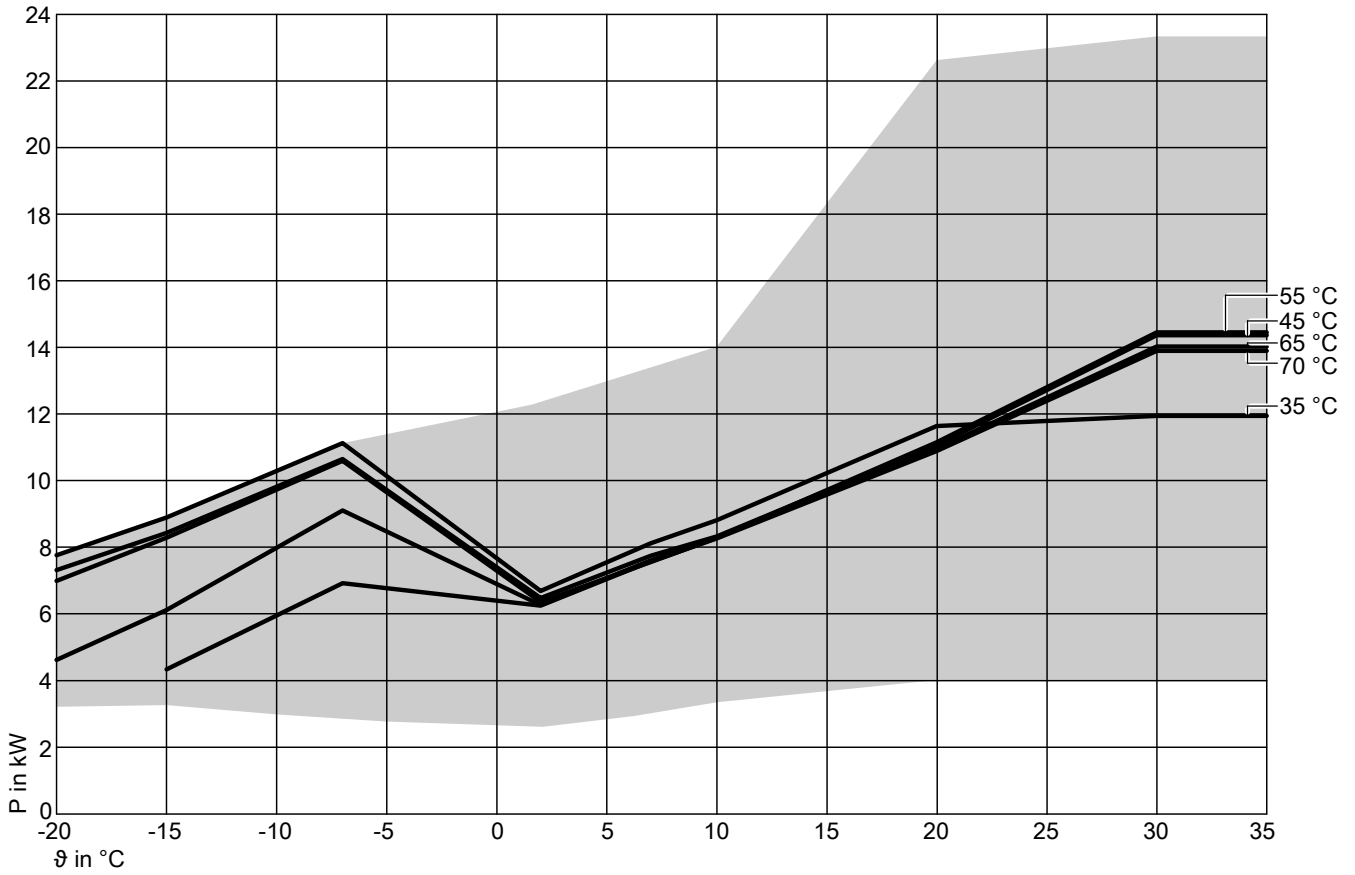

Possible output range

Power consumption for heating at flow temperatures of 35 °C, 45 °C, 55 °C, 65 °C, 70 °C

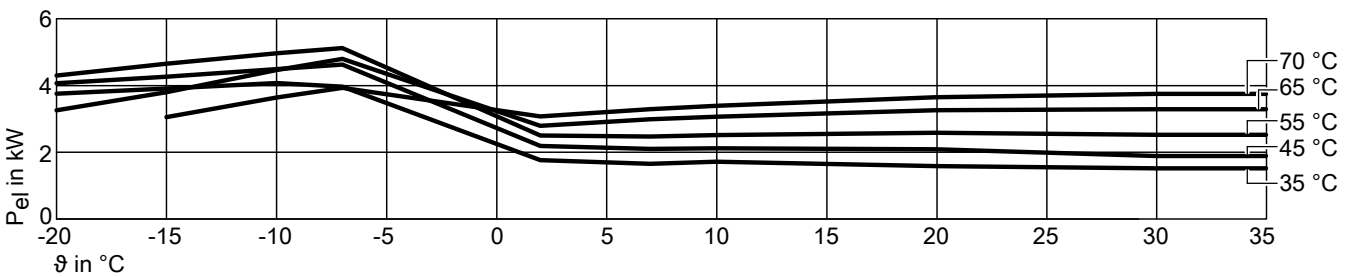

Curves (cont.)

Coefficient of performance (COP) at flow temperatures of 35 °C, 45 °C, 55 °C, 65 °C, 70 °C

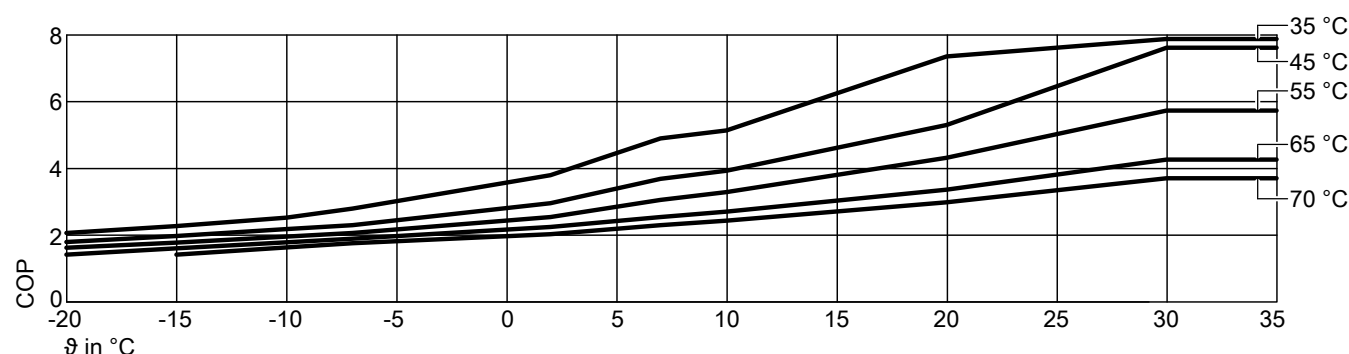

θ Air intake temperature
P Heating output
P_{el} Power consumption
COP Performance factor

Note

- The COP data in the tables and graphs was calculated with reference to EN 14511.
- Performance characteristics apply to new appliances with clean plate heat exchangers.

Operating point	W A	°C °C	35									
			-20	-15	-10	-7	2	7	10	20	30	35
Max. heating output		kW	7.77	8.90	10.30	11.13	12.34	13.40	14.02	22.63	23.34	23.34
Rated heating output		kW	7.77	8.90	10.30	11.10	6.70	8.10	8.82	11.65	11.95	11.95
Power consumption		kW	3.75	3.91	4.07	3.96	1.76	1.65	1.72	1.58	1.52	1.52
Coefficient of performance ε (COP)			2.07	2.28	2.53	2.80	3.80	4.90	5.14	7.35	7.88	7.88
Min. heating output		kW	3.22	3.27	2.99	2.82	2.61	3.00	3.35	4.02	4.02	4.02

Operating point	W A	°C °C	45									
			-20	-15	-10	-7	2	7	10	20	30	35
Max. heating output		kW	7.32	8.44	9.82	10.66	12.10	13.18	13.82	22.03	23.65	24.24
Rated heating output		kW	7.32	8.44	9.82	10.66	6.48	7.75	8.33	11.07	14.37	14.37
Power consumption		kW	4.07	4.26	4.49	4.63	2.19	2.10	2.12	2.09	1.89	1.89
Coefficient of performance ε (COP)			1.80	1.98	2.19	2.30	2.96	3.69	3.93	5.30	7.61	7.61
Min. heating output		kW	2.72	2.77	2.49	2.32	2.24	2.61	2.85	3.52	4.52	4.52

Operating point	W A	°C °C	55									
			-20	-15	-10	-7	2	7	10	20	30	35
Max. heating output		kW	7.00	8.29	9.74	10.60	12.28	13.33	17.27	20.65	22.88	23.20
Rated heating output		kW	7.00	8.29	9.74	10.60	6.37	7.56	8.28	11.16	14.46	14.46
Power consumption		kW	4.30	4.65	4.96	5.12	2.50	2.47	2.51	2.58	2.52	2.52
Coefficient of performance ε (COP)			1.63	1.78	1.96	2.07	2.55	3.06	3.29	4.32	5.73	5.73
Min. heating output		kW	2.70	2.74	2.48	2.32	3.03	3.51	3.84	5.07	6.10	6.10

Operating point	W A	°C °C	65									
			-20	-15	-10	-7	2	7	10	20	30	35
Max. heating output		kW	4.63	6.12	7.99	9.11	12.16	12.77	15.78	19.25	22.01	22.03
Rated heating output		kW	4.63	6.12	7.99	9.11	6.28	7.61	8.30	10.97	14.03	14.03
Power consumption		kW	3.26	3.80	4.46	4.80	2.79	2.99	3.06	3.26	3.29	3.29
Coefficient of performance ε (COP)			1.42	1.61	1.79	1.90	2.25	2.55	2.71	3.37	4.27	4.27
Min. heating output		kW	2.62	2.67	2.83	2.93	3.85	4.60	5.05	6.81	8.44	8.44

Operating point	W A	°C °C	70									
			-20	-15	-10	-7	2	7	10	20	30	35
Max. heating output		kW			5.96	6.93	9.83	11.78	14.76	17.83	21.74	21.78
Rated heating output		kW			5.96	6.93	6.25	7.58	8.27	10.90	13.90	13.90
Power consumption		kW			3.64	3.93	3.07	3.29	3.39	3.65	3.75	3.75
Coefficient of performance ε (COP)					1.64	1.76	2.03	2.30	2.44	2.99	3.71	3.71
Min. heating output		kW			3.15	3.43	4.57	5.36	5.88	7.97	9.48	9.48

Curves (cont.)

Cooling

Cooling capacity at flow temperature of 18 °C

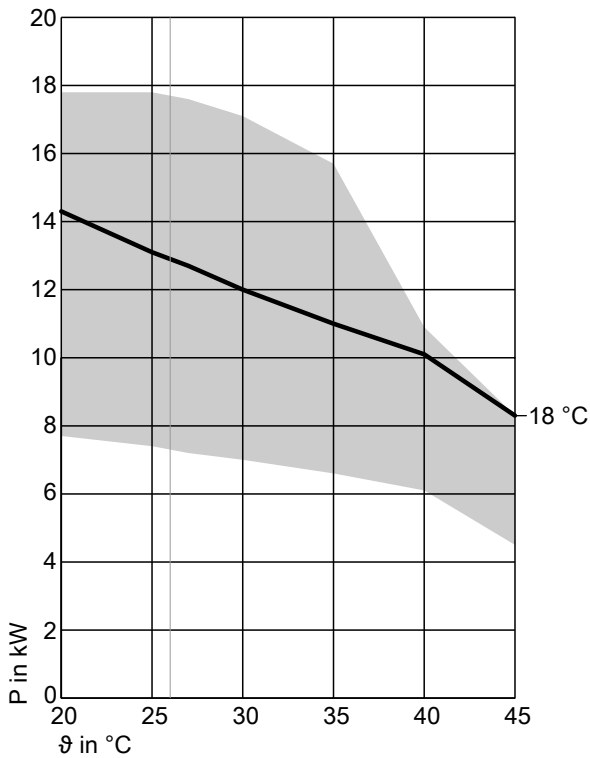

Possible output range

Power consumption for cooling at flow temperature of 18 °C

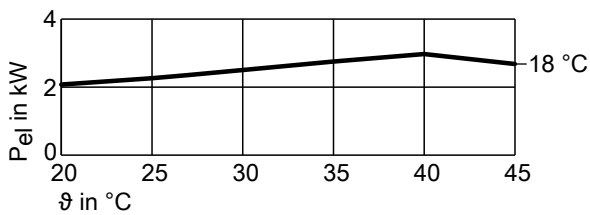

Energy efficiency ratio (EER) at flow temperature of 18 °C

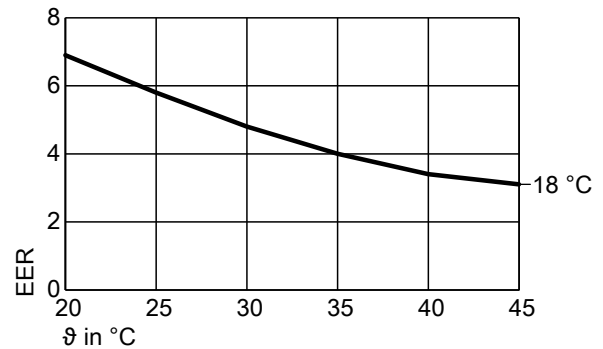

ϑ Air intake temperature

P Cooling capacity

P_{el} Power consumption

EER Performance factor

Note

- The EER data in the tables and graphs was calculated with reference to EN 14511.
- Performance characteristics apply to new appliances with clean plate heat exchangers.

Operating point	W A	°C °C	18						
			20	25	27	30	35	40	45
Max. cooling capacity		kW	17.80	17.80	17.60	17.10	15.70	10.60	8.30
Cooling capacity		kW	14.30	13.10	12.70	12.00	11.00	10.10	8.30
Power consumption		kW	2.07	2.26	2.35	2.50	2.75	2.97	2.68
Energy efficiency ratio EER			6.90	5.80	5.40	4.80	4.00	3.40	3.10
Min. cooling capacity		kW	7.70	7.40	7.20	7.00	6.60	6.10	4.50

5.4 Performance graph, outdoor unit type 151.A13, 400 V~

Heating

Heating output at flow temperatures of 35 °C, 45 °C, 55 °C, 65 °C, 70 °C

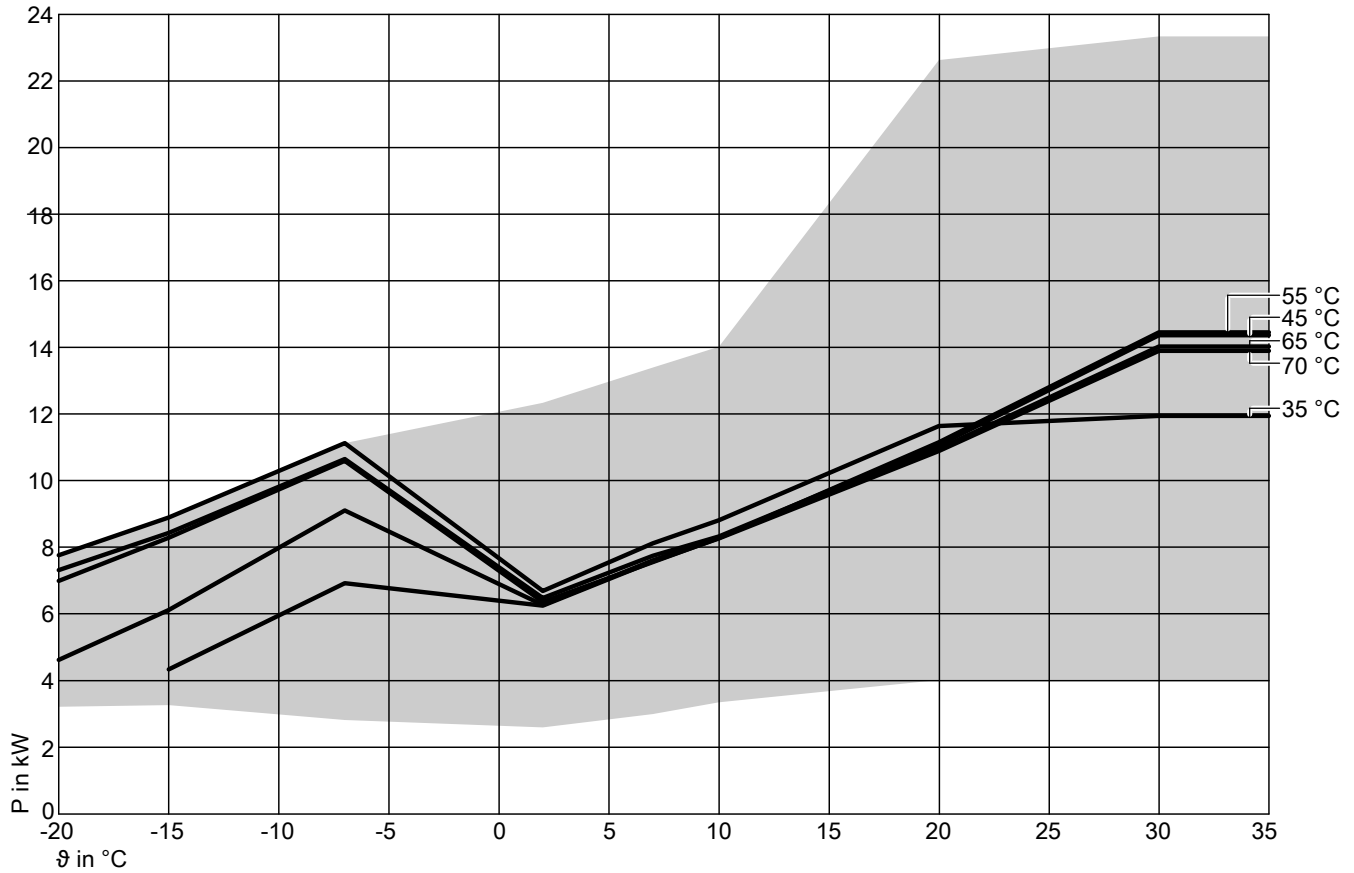

Possible output range

Power consumption for heating at flow temperatures of 35 °C, 45 °C, 55 °C, 65 °C, 70 °C

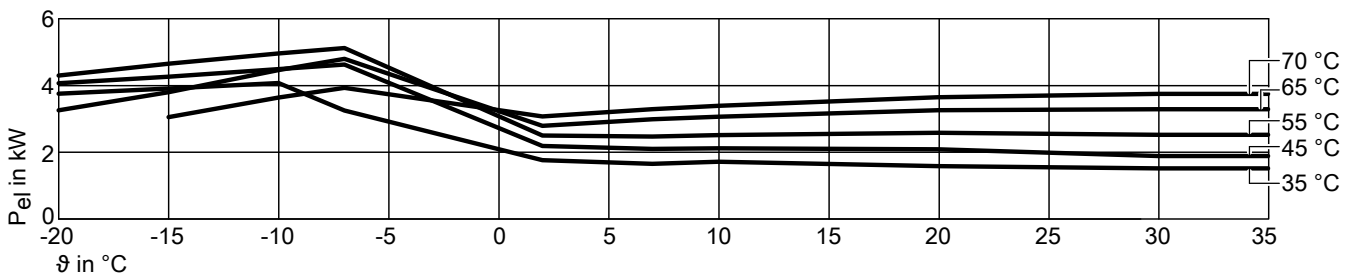

Curves (cont.)

Coefficient of performance (COP) at flow temperatures of 35 °C, 45 °C, 55 °C, 65 °C, 70 °C

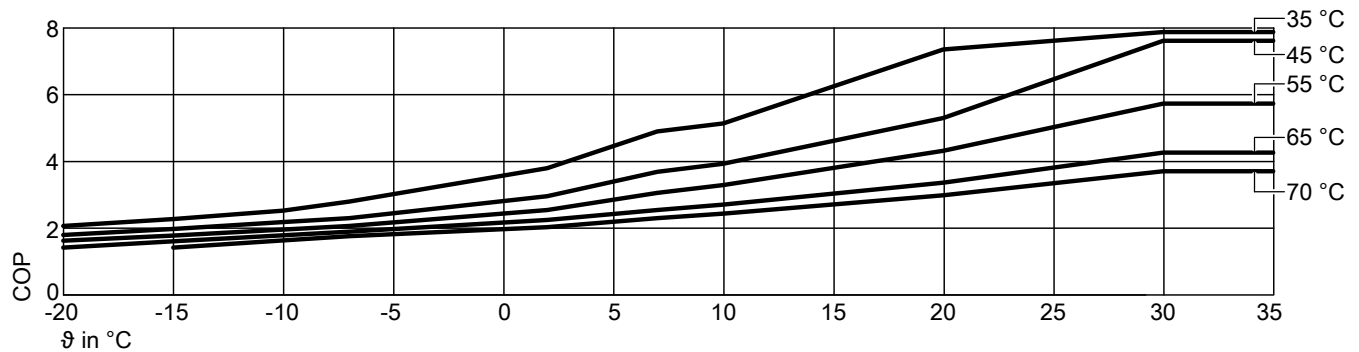

θ Air intake temperature
P Heating output
P_{el} Power consumption
COP Performance factor

Note

- The COP data in the tables and graphs was calculated with reference to EN 14511.
- Performance characteristics apply to new appliances with clean plate heat exchangers.

Operating point	W A	°C °C	35									
			-20	-15	-10	-7	2	7	10	20	30	35
Max. heating output		kW	7.77	8.90	10.30	11.13	12.34	13.40	14.02	22.63	23.34	23.34
Rated heating output		kW	7.77	8.90	10.30	11.10	6.70	8.10	8.82	11.65	11.95	11.95
Power consumption		kW	3.75	3.91	4.07	3.96	1.76	1.65	1.72	1.58	1.52	1.52
Coefficient of performance ε (COP)			2.07	2.28	2.53	2.80	3.80	4.90	5.14	7.35	7.88	7.88
Min. heating output		kW	3.22	3.27	2.99	2.82	2.61	3.00	3.35	4.02	4.02	4.02

Operating point	W A	°C °C	45									
			-20	-15	-10	-7	2	7	10	20	30	35
Max. heating output		kW	7.32	8.44	9.82	10.66	12.10	13.18	13.82	22.03	23.65	24.24
Rated heating output		kW	7.32	8.44	9.82	10.66	6.48	7.75	8.33	11.07	14.37	14.37
Power consumption		kW	4.07	4.26	4.49	4.63	2.19	2.10	2.12	2.09	1.89	1.89
Coefficient of performance ε (COP)			1.80	1.98	2.19	2.30	2.96	3.69	3.93	5.30	7.61	7.61
Min. heating output		kW	2.72	2.77	2.49	2.32	2.24	2.61	2.85	3.52	4.52	4.52

Operating point	W A	°C °C	55									
			-20	-15	-10	-7	2	7	10	20	30	35
Max. heating output		kW	7.00	8.29	9.74	10.60	12.28	13.33	17.27	20.65	22.88	23.20
Rated heating output		kW	7.00	8.29	9.73	10.60	6.37	7.56	8.28	11.16	14.46	14.46
Power consumption		kW	4.30	4.65	4.96	5.12	2.50	2.47	2.51	2.58	2.52	2.52
Coefficient of performance ε (COP)			1.63	1.78	1.96	2.07	2.55	3.06	3.29	4.32	5.73	5.73
Min. heating output		kW	2.70	2.74	2.48	2.32	3.03	3.51	3.84	5.07	6.10	6.10

Operating point	W A	°C °C	65									
			-20	-15	-10	-7	2	7	10	20	30	35
Max. heating output		kW	4.63	6.12	7.99	9.11	12.16	12.77	15.78	19.25	22.01	22.03
Rated heating output		kW	4.63	6.12	7.99	9.11	6.28	7.61	8.30	10.97	14.03	14.03
Power consumption		kW	3.26	3.80	4.46	4.80	2.79	2.99	3.06	3.26	3.29	3.29
Coefficient of performance ε (COP)			1.42	1.61	1.79	1.90	2.25	2.55	2.71	3.37	4.27	4.27
Min. heating output		kW	2.62	2.67	2.83	2.93	3.85	4.60	5.05	6.81	8.44	8.44

Operating point	W A	°C °C	70									
			-20	-15	-10	-7	2	7	10	20	30	35
Max. heating output		kW			5.96	6.93	9.83	11.78	14.76	17.83	21.74	21.78
Rated heating output		kW			5.96	6.93	6.25	7.58	8.27	10.90	13.90	13.90
Power consumption		kW			3.64	3.93	3.07	3.29	3.39	3.65	3.75	3.75
Coefficient of performance ε (COP)					1.64	1.76	2.03	2.30	2.44	2.99	3.71	3.71
Min. heating output		kW			3.15	3.43	4.57	5.36	5.88	7.97	9.48	9.48

Curves (cont.)

Cooling

Cooling capacity at flow temperature of 18 °C

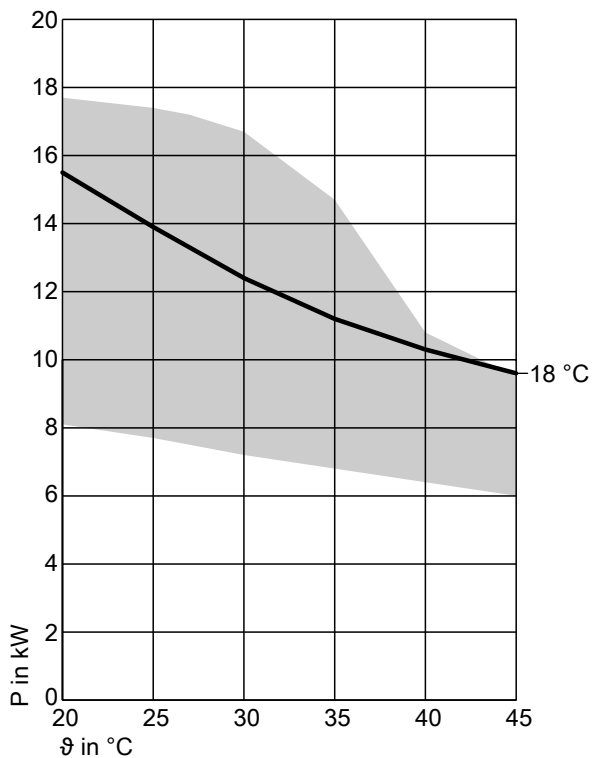

Energy efficiency ratio (EER) at flow temperature of 18 °C

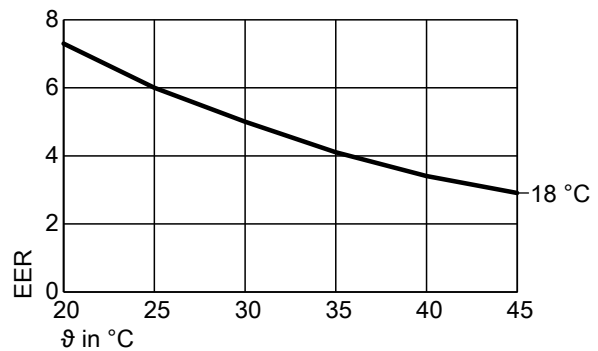

ϑ Air intake temperature

P Cooling capacity

P_{el} Power consumption

EER Performance factor

Note

- The EER data in the tables and graphs was calculated with reference to EN 14511.
- Performance characteristics apply to new appliances with clean plate heat exchangers.

Possible output range

5

Power consumption for cooling at flow temperature of 18 °C

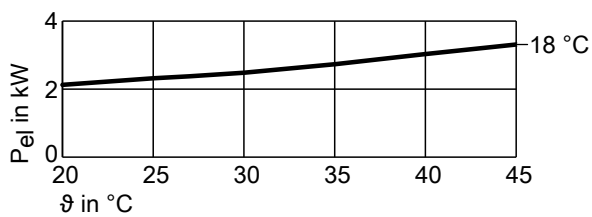

Operating point	W A	°C °C	18						
			20	25	27	30	35	40	45
Max. cooling capacity		kW	17.70	17.40	17.20	16.70	14.70	10.80	9.60
Cooling capacity		kW	15.50	13.90	13.30	12.40	11.20	10.30	9.60
Power consumption		kW	2.12	2.32	2.38	2.48	2.73	3.03	3.31
Energy efficiency ratio EER			7.30	6.00	5.60	5.00	4.10	3.40	2.90
Min. cooling capacity		kW	8.10	7.70	7.50	7.20	6.80	6.40	6.00

5.5 Performance graph, outdoor unit type 151.A16, 230 V~

Heating

Heating output at flow temperatures of 35 °C, 45 °C, 55 °C, 65 °C, 70 °C

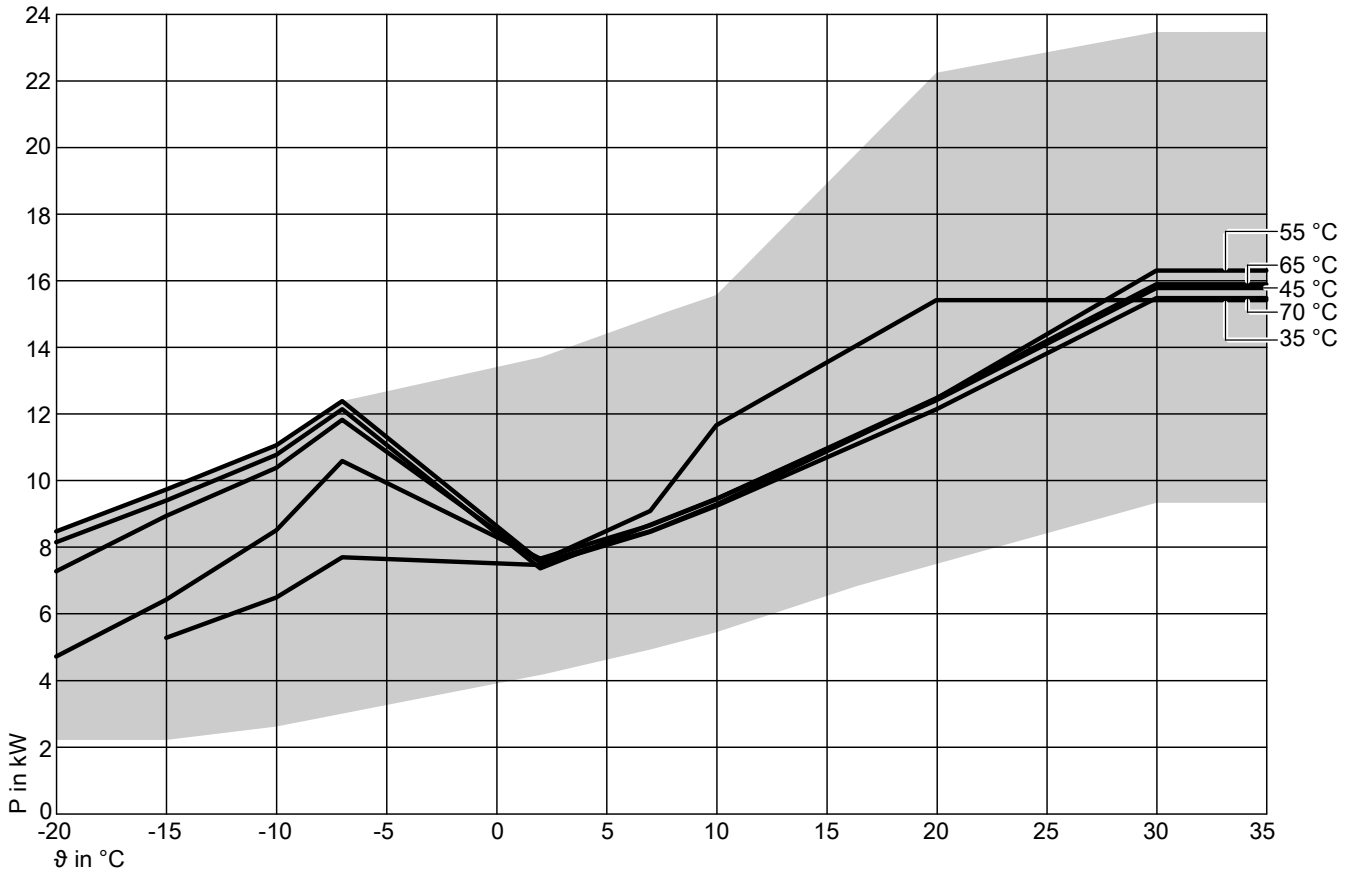

Possible output range

Power consumption for heating at flow temperatures of 35 °C, 45 °C, 55 °C, 65 °C, 70 °C

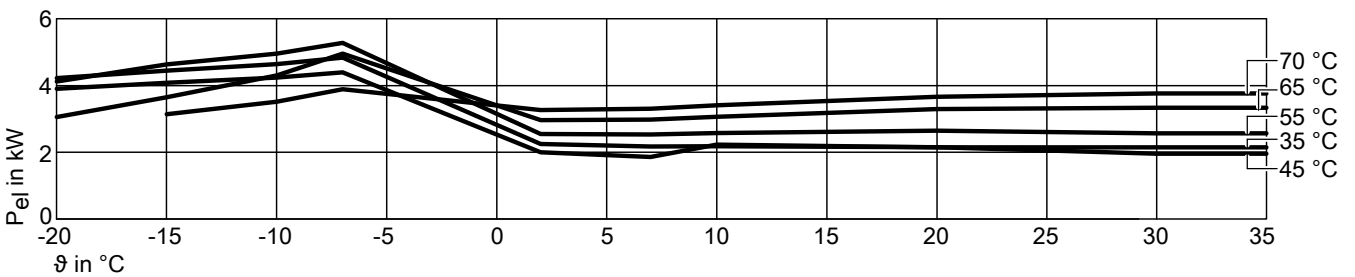

Curves (cont.)

Coefficient of performance (COP) at flow temperatures of 35 °C, 45 °C, 55 °C, 65 °C, 70 °C

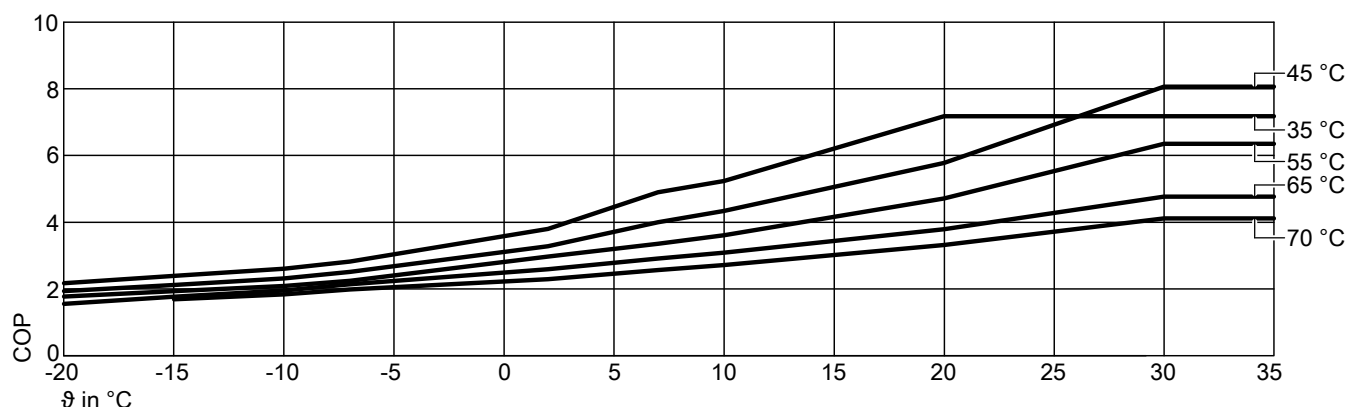

θ Air intake temperature
P Heating output
P_{el} Power consumption
COP Performance factor

Note

- The COP data in the tables and graphs was calculated with reference to EN 14511.
- Performance characteristics apply to new appliances with clean plate heat exchangers.

Operating point	W A	°C °C	35									
			-20	-15	-10	-7	2	7	10	20	30	35
Max. heating output		kW	8.49	9.74	11.07	12.39	13.70	14.90	15.57	22.24	23.46	23.46
Rated heating output		kW	8.49	9.74	11.07	12.39	7.59	9.10	11.67	15.42	15.42	15.42
Power consumption		kW	3.90	4.08	4.24	4.39	2.00	1.86	2.23	2.15	2.15	2.15
Coefficient of performance ε (COP)			2.17	2.39	2.61	2.82	3.80	4.90	5.24	7.18	7.18	7.18
Min. heating output		kW	3.00	3.00	3.00	3.00	3.00	3.30	3.30	3.55	3.55	3.55

Operating point	W A	°C °C	45									
			-20	-15	-10	-7	2	7	10	20	30	35
Max. heating output		kW	8.16	9.41	10.78	12.15	13.62	14.89	19.58	21.78	24.01	24.01
Rated heating output		kW	8.16	9.41	10.78	12.15	7.38	8.68	9.46	12.42	15.79	15.79
Power consumption		kW	4.22	4.45	4.64	4.84	2.25	2.17	2.18	2.15	1.96	1.96
Coefficient of performance ε (COP)			1.93	2.12	2.31	2.51	3.28	4.00	4.34	5.78	8.07	8.07
Min. heating output		kW	2.52	2.56	2.34	2.11	2.03	2.37	2.60	3.49	4.14	4.14

Operating point	W A	°C °C	55									
			-20	-15	-10	-7	2	7	10	20	30	35
Max. heating output		kW	7.29	8.95	10.39	11.83	13.74	14.58	18.48	21.59	23.35	23.02
Rated heating output		kW	7.29	8.95	10.39	11.83	7.56	8.49	9.29	12.47	16.31	16.31
Power consumption		kW	4.12	4.63	4.96	5.28	2.55	2.53	2.57	2.65	2.57	2.57
Coefficient of performance ε (COP)			1.77	1.93	2.09	2.24	2.97	3.35	3.61	4.71	6.36	6.36
Min. heating output		kW	2.31	2.35	2.14	1.93	2.64	3.13	3.44	4.69	5.56	5.56

Operating point	W A	°C °C	65									
			-20	-15	-10	-7	2	7	10	20	30	35
Max. heating output		kW	4.73	6.44	8.52	10.60	13.44	13.31	16.11	19.67	22.48	22.07
Rated heating output		kW	4.73	6.44	8.52	10.60	7.67	8.67	9.45	12.48	15.90	15.90
Power consumption		kW	3.06	3.65	4.30	4.96	2.96	2.98	3.06	3.29	3.33	3.33
Coefficient of performance ε (COP)			1.55	1.77	1.95	2.14	2.59	2.91	3.09	3.79	4.77	4.77
Min. heating output		kW	2.21	2.27	2.42	2.56	3.54	4.16	4.65	6.38	7.83	7.83

Operating point	W A	°C °C	70									
			-20	-15	-10	-7	2	7	10	20	30	35
Max. heating output		kW			6.50	7.71	10.87	12.66	15.01	18.17	22.12	21.79
Rated heating output		kW			6.50	7.71	7.48	8.47	9.25	12.15	15.48	15.48
Power consumption		kW			3.51	3.89	3.26	3.30	3.41	3.66	3.76	3.76
Coefficient of performance ε (COP)					1.83	1.98	2.29	2.57	2.72	3.32	4.12	4.12
Min. heating output		kW			2.63	3.04	4.18	4.94	5.46	7.63	9.34	9.34

Curves (cont.)

Cooling

Cooling capacity at flow temperature of 18 °C

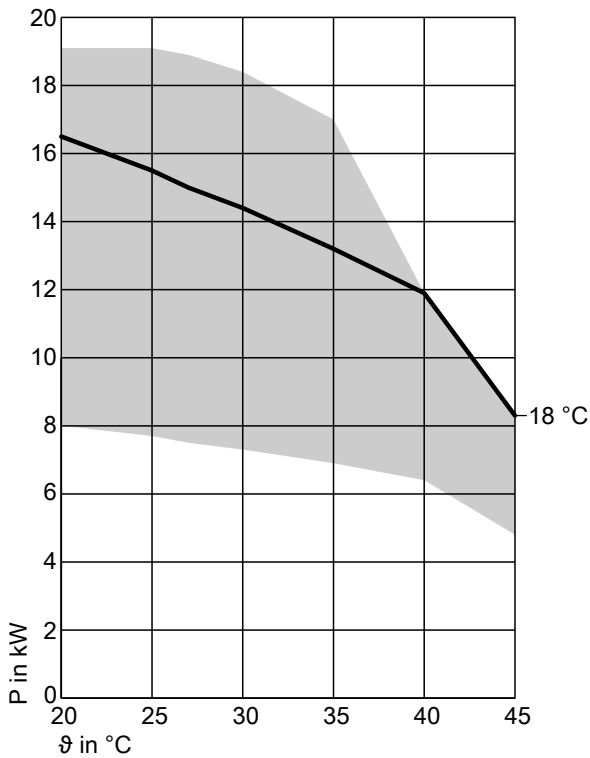

█ Possible output range

Power consumption for cooling at flow temperature of 18 °C

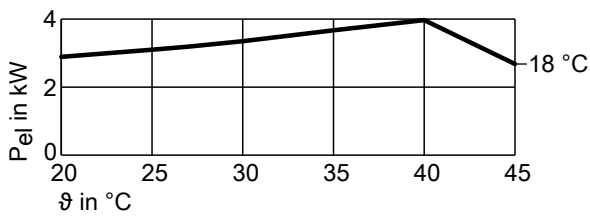

Energy efficiency ratio (EER) at flow temperature of 18 °C

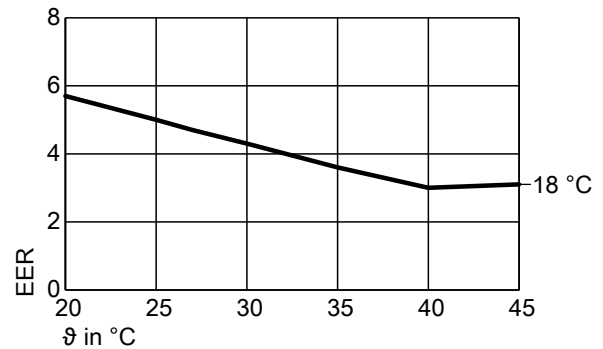

ϑ Air intake temperature

P Cooling capacity

P_{el} Power consumption

EER Performance factor

Note

- The EER data in the tables and graphs was calculated with reference to EN 14511.
- Performance characteristics apply to new appliances with clean plate heat exchangers.

Operating point	W A	°C °C	18						
			20	25	27	30	35	40	45
Max. cooling capacity		kW	19.10	19.10	18.90	18.40	17.00	11.90	8.30
Cooling capacity		kW	16.50	15.50	15.00	14.40	13.20	11.90	8.30
Power consumption		kW	2.89	3.10	3.19	3.35	3.62	3.97	2.68
Energy efficiency ratio EER			5.70	5.00	4.70	4.30	3.65	3.00	3.10
Min. cooling capacity		kW	8.00	7.70	7.50	7.30	6.90	6.40	4.80

5.6 Performance graph, outdoor unit type 151.A16, 400 V~

Heating

Heating output at flow temperatures of 35 °C, 45 °C, 55 °C, 65 °C, 70 °C

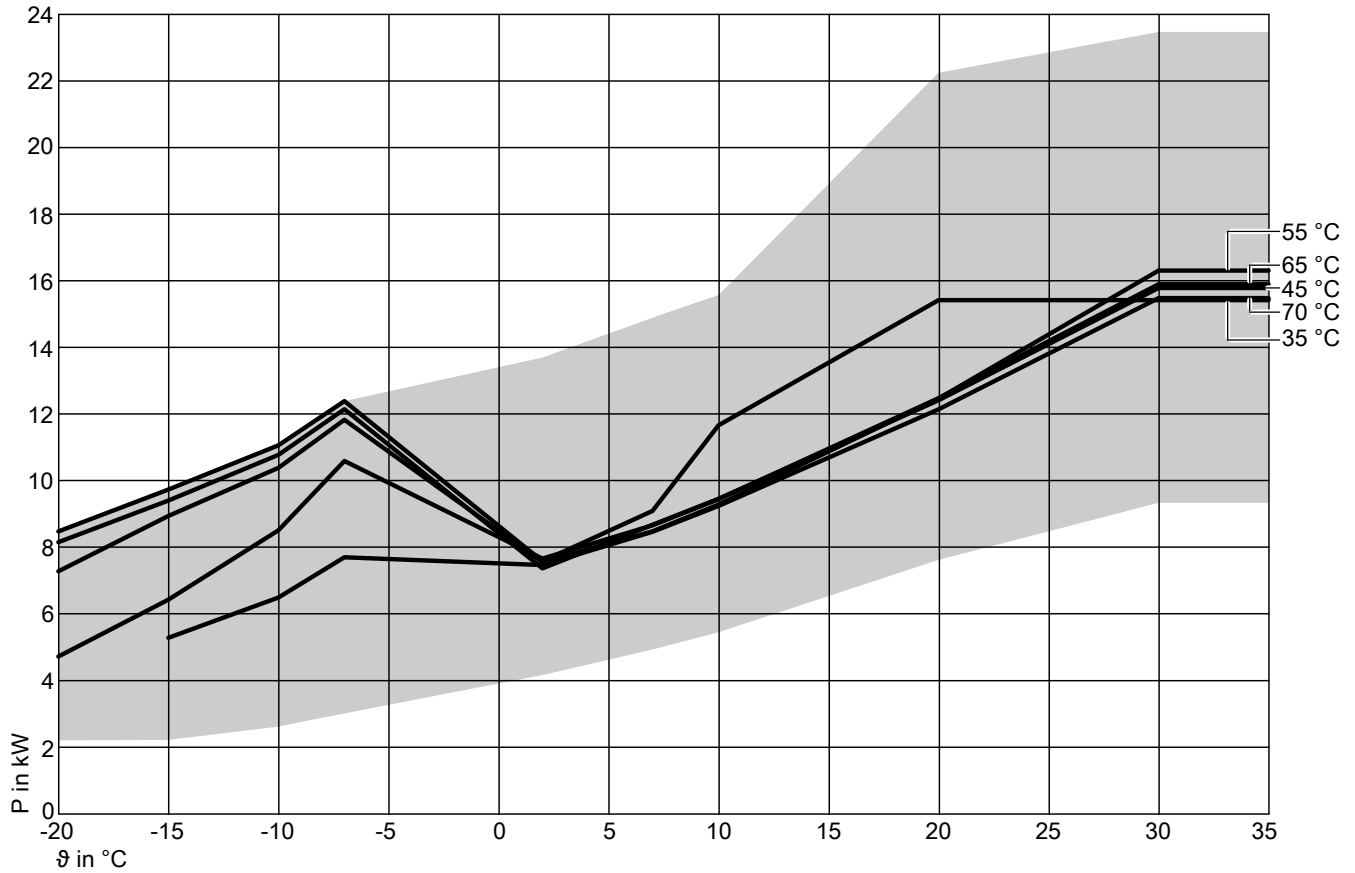

Possible output range

Power consumption for heating at flow temperatures of 35 °C, 45 °C, 55 °C, 65 °C, 70 °C

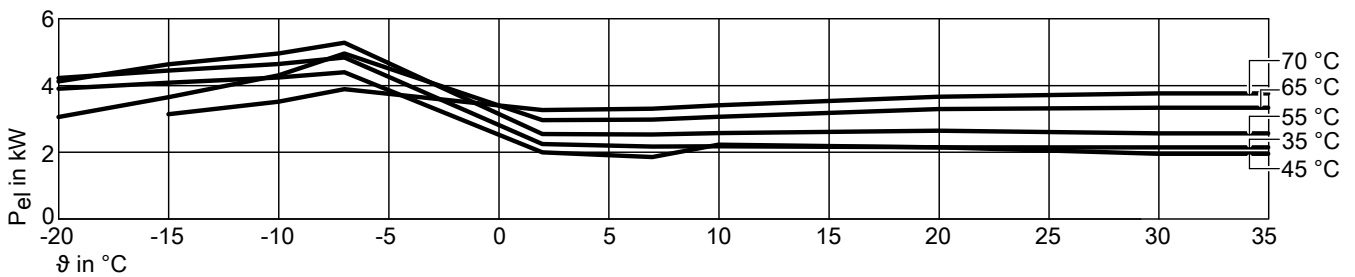

Curves (cont.)

Coefficient of performance (COP) at flow temperatures of 35 °C, 45 °C, 55 °C, 65 °C, 70 °C

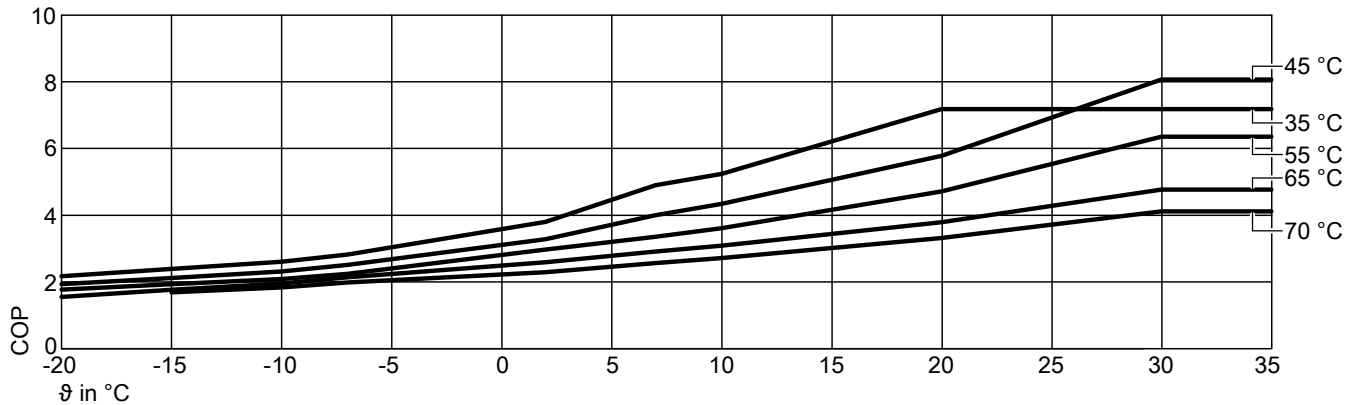

ϑ Air intake temperature
P Heating output
P_{el} Power consumption
COP Performance factor

Note

- The COP data in the tables and graphs was calculated with reference to EN 14511.
- Performance characteristics apply to new appliances with clean plate heat exchangers.

Operating point	W A	°C °C	35									
			-20	-15	-10	-7	2	7	10	20	30	35
Max. heating output		kW	8.49	9.74	11.07	12.39	13.70	14.90	15.57	22.24	23.46	23.46
Rated heating output		kW	8.49	9.74	11.07	12.39	7.59	9.10	11.67	15.42	15.42	15.42
Power consumption		kW	3.90	4.08	4.24	4.39	2.00	1.86	2.23	2.15	2.15	2.15
Coefficient of performance ε (COP)			2.17	2.39	2.61	2.82	3.80	4.90	5.24	7.18	7.18	7.18
Min. heating output		kW	2.75	2.80	2.58	2.35	2.27	2.64	2.88	3.55	3.55	3.55

Operating point	W A	°C °C	45									
			-20	-15	-10	-7	2	7	10	20	30	35
Max. heating output		kW	8.16	9.41	10.78	12.15	13.62	14.89	19.58	21.78	24.01	24.01
Rated heating output		kW	8.16	9.41	10.78	12.15	7.38	8.68	9.46	12.42	15.79	15.79
Power consumption		kW	4.22	4.45	4.64	4.84	2.25	2.17	2.18	2.15	1.96	1.96
Coefficient of performance ε (COP)			1.93	2.12	2.31	2.51	3.28	4.00	4.34	5.78	8.07	8.07
Min. heating output		kW	2.52	2.56	2.34	2.11	2.03	2.37	2.60	3.49	4.14	4.14

Operating point	W A	°C °C	55									
			-20	-15	-10	-7	2	7	10	20	30	35
Max. heating output		kW	7.29	8.95	10.39	11.83	13.74	14.58	18.48	21.59	23.35	23.02
Rated heating output		kW	7.29	8.95	10.39	11.83	7.56	8.49	9.29	12.47	16.31	16.31
Power consumption		kW	4.12	4.63	4.96	5.28	2.55	2.53	2.57	2.65	2.57	2.57
Coefficient of performance ε (COP)			1.77	1.93	2.09	2.24	2.97	3.35	3.61	4.71	6.36	6.36
Min. heating output		kW	2.31	2.35	2.14	1.93	2.64	3.13	3.44	4.69	5.56	5.56

Operating point	W A	°C °C	65									
			-20	-15	-10	-7	2	7	10	20	30	35
Max. heating output		kW	4.73	6.44	8.52	10.60	13.44	13.31	16.11	19.67	22.48	22.07
Rated heating output		kW	4.73	6.44	8.52	10.60	7.67	8.67	9.45	12.48	15.90	15.90
Power consumption		kW	3.06	3.65	4.30	4.96	2.96	2.98	3.06	3.29	3.33	3.33
Coefficient of performance ε (COP)			1.55	1.77	1.95	2.14	2.59	2.91	3.09	3.79	4.77	4.77
Min. heating output		kW	2.21	2.27	2.42	2.56	3.54	4.16	4.65	6.38	7.83	7.83

Operating point	W A	°C °C	70									
			-20	-15	-10	-7	2	7	10	20	30	35
Max. heating output		kW			6.50	7.71	10.87	12.66	15.01	18.17	22.12	21.79
Rated heating output		kW			6.50	7.71	7.48	8.47	9.25	12.15	15.48	15.48
Power consumption		kW			3.51	3.89	3.26	3.30	3.41	3.66	3.76	3.76
Coefficient of performance ε (COP)					1.83	1.98	2.29	2.57	2.72	3.32	4.12	4.12
Min. heating output		kW			2.63	3.04	4.18	4.94	5.46	7.63	9.34	9.34

Curves (cont.)

Cooling

Cooling capacity at flow temperature of 18 °C

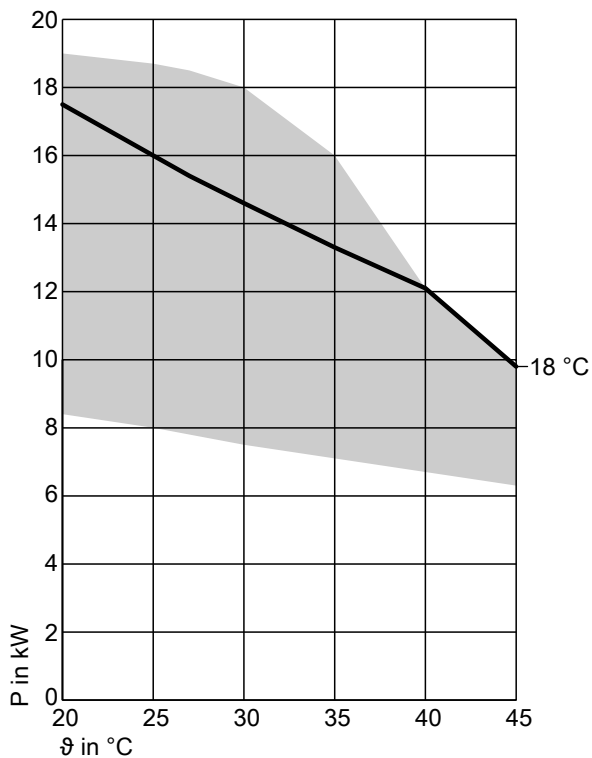

Energy efficiency ratio (EER) at flow temperature of 18 °C

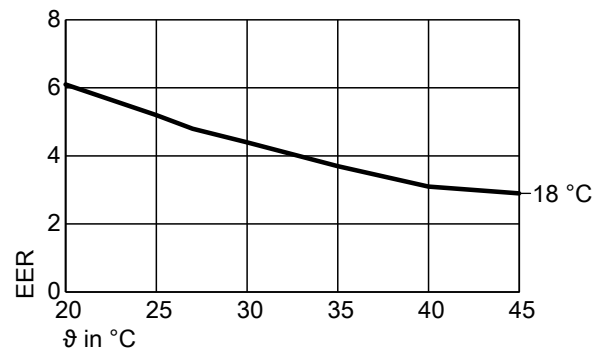

ϑ Air intake temperature
 P Cooling capacity
 P_{el} Power consumption
 EER Performance factor

Note

- The EER data in the tables and graphs was calculated with reference to EN 14511.
- Performance characteristics apply to new appliances with clean plate heat exchangers.

Possible output range

Power consumption for cooling at flow temperature of 18 °C

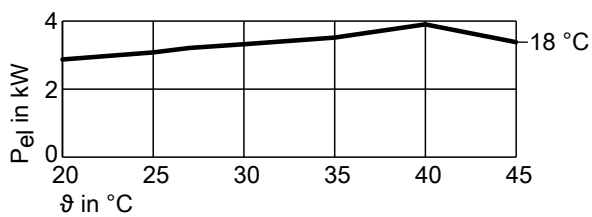

Operating point	W A	°C °C	18						
			20	25	27	30	35	40	45
Max. cooling capacity		kW	19.00	18.70	18.50	18.00	16.00	12.10	9.80
Cooling capacity		kW	17.50	16.00	15.40	14.60	13.30	12.10	9.80
Power consumption		kW	2.87	3.08	3.21	3.32	3.59	3.90	3.38
Energy efficiency ratio EER			6.10	5.20	4.80	4.40	3.70	3.10	2.90
Min. cooling capacity		kW	8.40	8.00	7.80	7.50	7.10	6.70	6.30

Installation accessories

6.1 DHW heating with Vitocell 100-V/100-W, type CVWA/CVWB (300 l/390 l/500 l)

For Vitocal 150-A

Vitocell 100-V/100-W, type CVWA/CVWB, Vitopearlwhite

Observe the information on sizing DHW cylinders: See page 90 onwards.

Part no.	Cylinder type	Cylinder capacity
Z021898	CVWB	300 l
Z021899	CVWA	390 l
Z021900	CVWA	500 l

Observe the information on sizing DHW cylinders: See page 90 onwards.

Information on continuous output

When designing systems with the specified or calculated continuous output, allow for a matching circulation pump. The stated continuous output is achieved only if the heat generator's rated heating output is \geq continuous output.

Sizing entry points

The actual dimensions of the DHW cylinder may vary slightly due to manufacturing tolerances.

Specification

Type		CVWB	CVWA		
Cylinder capacity (AT: Actual water capacity)	l	300	390	500	
Heating water capacity	l	22	27	40	
Gross volume	l	322	417	540	
DIN registration no.		Applied for	9W173-13MC/E		
Continuous output at heating water flow rate stated below					
– For DHW heating from 10 to 45 °C and following heating water flow temperatures					
	90 °C	kW	85	98	118
		l/h	2093	2422	2896
	80 °C	kW	71	82	99
		l/h	1749	2027	2428
	70 °C	kW	57	66	79
		l/h	1399	1623	1950
	60 °C	kW	42	49	59
		l/h	1033	1202	1451
	50 °C	kW	25	29	36
		l/h	617	723	881
– For DHW heating from 10 to 60 °C and following heating water flow temperatures					
	90 °C	kW	73	85	102
		l/h	1255	1458	1754
	80 °C	kW	58	67	81
		l/h	995	1159	1399
	70 °C	kW	41	48	59
		l/h	710	830	1008
Heating water flow rate for the stated continuous outputs	m ³ /h		3.0	3.0	3.0
Draw-off rate	l/min		15	15	15
Drawable water volume without reheating					
– Cylinder content heated to 45 °C					
	l		210	285	350
Water at t = 45 °C (constant)					
– Cylinder content heated to 55 °C					
	l		210	285	350
Water at t = 55 °C (constant)					
Heat-up time if connected to a heat pump with 16 kW rated heating output and a heating water flow temperature of 55 or 65 °C					
– For DHW heating from 10 to 45 °C					
	min		50	60	66
– For DHW heating from 10 to 55 °C					
	min		60	76	85
Max. connectible heat pump output at 65 °C heating water flow and 55 °C DHW temperature and the specified heating water flow rate					
	kW		12	15	17
Max. aperture area that can be connected to the solar heat exchanger set (accessories)					
– Vitosol-T					
	m ²		—	6	6
– Vitosol-F					
	m ²		—	11.5	11.5
Performance factor N_L in conjunction with a heat pump					
Cylinder storage temperature					
	45 °C		1.7	2.5	3.5
	50 °C		1.9	2.8	3.9
Standby heat loss	kWh/24 h		1.62	1.80	1.90

Installation accessories (cont.)

Type		CVWB	CVWA	
Cylinder capacity (AT: Actual water capacity)	I	300	390	500
Permissible temperatures				
– Heating water side	°C	110	110	110
– DHW side	°C	95	95	95
– Solar side	°C	140	140	140
Permissible operating pressure				
– Heating water side	bar	10	10	10
	MPa	1.0	1.0	1.0
– DHW side	bar	10	10	10
	MPa	1.0	1.0	1.0
– Solar side	bar	10	10	10
	MPa	1.0	1.0	1.0
Dimensions				
Length a (∅)				
– Incl. thermal insulation	mm	668	859	859
– Excl. thermal insulation	mm	—	650	650
Total width b				
– Incl. thermal insulation	mm	714	923	923
– Excl. thermal insulation	mm	—	881	881
Height c				
– Incl. thermal insulation	mm	1687	1624	1948
– Excl. thermal insulation	mm	—	1522	1844
Height when tilted				
– Incl. thermal insulation	mm	1790	—	—
– Excl. thermal insulation	mm	—	1550	1860
Total weight incl. thermal insulation	kg	150	190	200
Heating surface	m ²	3.0	4.0	5.5
Connections				
Heating water flow and return (male thread)	R	1¼	1¼	1¼
Cold water, DHW (male thread)	R	1	1¼	1¼
Solar heat exchanger set (male thread)	R	—	¾	¾
DHW circulation (male thread)	R	¾	¾	¾
Immersion heater (female thread)	Rp	1½	1½	1½
Energy efficiency class		B	B	B
Colour				
– Vitocell 100-V		Vitosilver	Vitosilver or Vitopearlwhite	
– Vitocell 100-W		Vitopearlwhite	—	

Installation accessories (cont.)

Measurements, type CVWB, 300 l capacity

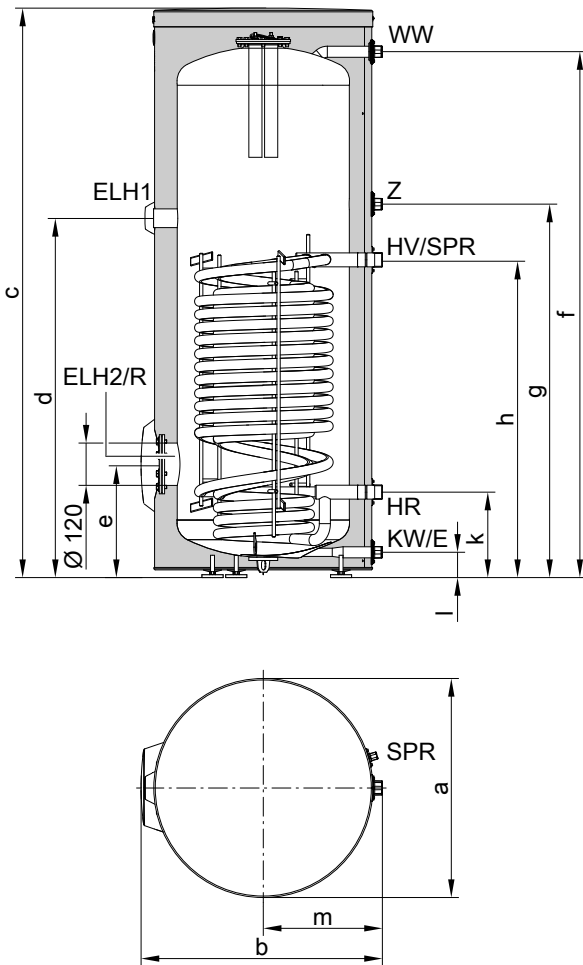

- E Drain
- ELH1 Connector for immersion heater
- ELH2 Flanged aperture for immersion heater
- HR Heating water return
- HV Heating water flow
- KW Cold water
- R Inspection and cleaning aperture with flange cover
- SPR Clamping device for securing immersion temperature sensors to the cylinder jacket, with fixing points for 3 immersion temperature sensors
- WW DHW
- Z DHW circulation

Dimensions of type CVWB

Cylinder capacity		I	300
Length (∅)	a	mm	668
Width	b	mm	714
Height	c	mm	1687
	d	mm	1100
	e	mm	351
	f	mm	1607
	g	mm	1143
	h	mm	974
	k	mm	266
	l	mm	83
	m	mm	362

Measurements, type CVWA, 390, 500 l capacity

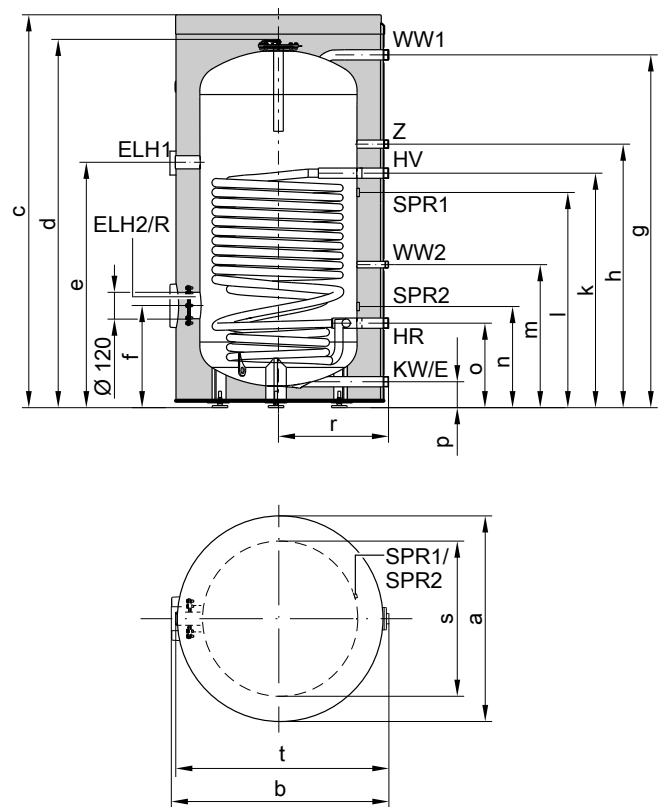

- E Drain
- ELH1 Connector for immersion heater
- ELH2 Flanged aperture for immersion heater
- HR Heating water return
- HV Heating water flow
- KW Cold water
- R Inspection and cleaning aperture with flange cover
- SPR1 Clamping device for securing immersion temperature sensors to the cylinder jacket, with fixing points for 3 immersion temperature sensors
- SPR2 Clamping device for securing immersion temperature sensors to the cylinder jacket, with fixing points for 3 immersion temperature sensors
- WW1 DHW
- WW2 DHW from solar heat exchanger set
- Z DHW circulation

Dimensions of type CVWA

Cylinder capacity		I	390	500
Length (∅)	a	mm	859	859
Width	b	mm	923	923
Height	c	mm	1624	1948
	d	mm	1522	1844
	e	mm	1000	1307
	f	mm	403	442
	g	mm	1439	1765
	h	mm	1070	1370
	k	mm	950	1250
	l	mm	816	1116
	m	mm	572	572
	n	mm	366	396
	o	mm	330	330
	p	mm	88	88
	r	mm	455	455
	s	mm	650	650
	t	mm	881	881

Installation accessories (cont.)

Performance factor N_L to DIN 4708

Cylinder capacity	l	300	390	500
Performance factor N_L				
Heating water flow temperature				
90 °C		9.5	12.6	16.5
80 °C		8.5	11.3	14.9
70 °C		7.5	10.0	13.3

- The performance factor N_L depends on the cylinder storage temperature T_{cyl} .
- Cylinder storage temperature T_{cyl} = cold water inlet temperature + 50 K ^{+5 K/-0 K}

Standard values for performance factor N_L

- $T_{cyl} = 60\text{ °C} \rightarrow 1.0 \times N_L$
- $T_{cyl} = 55\text{ °C} \rightarrow 0.75 \times N_L$
- $T_{cyl} = 50\text{ °C} \rightarrow 0.55 \times N_L$
- $T_{cyl} = 45\text{ °C} \rightarrow 0.3 \times N_L$

Peak output over 10 min, relative to performance factor N_L

Cylinder capacity	l	300	390	500
Peak output for heating the DHW from 10 to 45 °C				
Heating water flow temperature				
90 °C	l/10 min	415	540	690
80 °C	l/10 min	400	521	667
70 °C	l/10 min	357	455	596

Max. draw-off rate over 10 min., relative to performance factor N_L

Cylinder capacity	l	300	390	500
Max. draw-off rate for DHW heating from 10 to 45 °C, with reheating				
Heating water flow temperature				
90 °C	l/min	41	54	69
80 °C	l/min	40	52	66
70 °C	l/min	35	46	59

Pressure drop on the DHW side

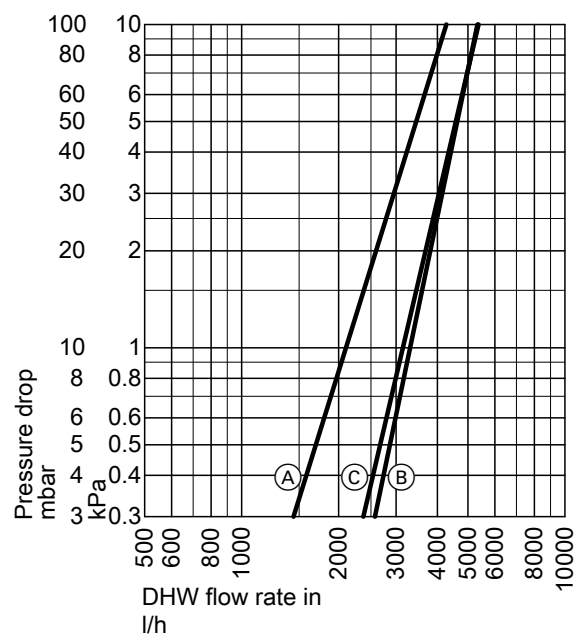

- (A) Cylinder capacity 300 l
- (B) Cylinder capacity 390 l
- (C) Cylinder capacity 500 l

Pressure drop on the heating water side

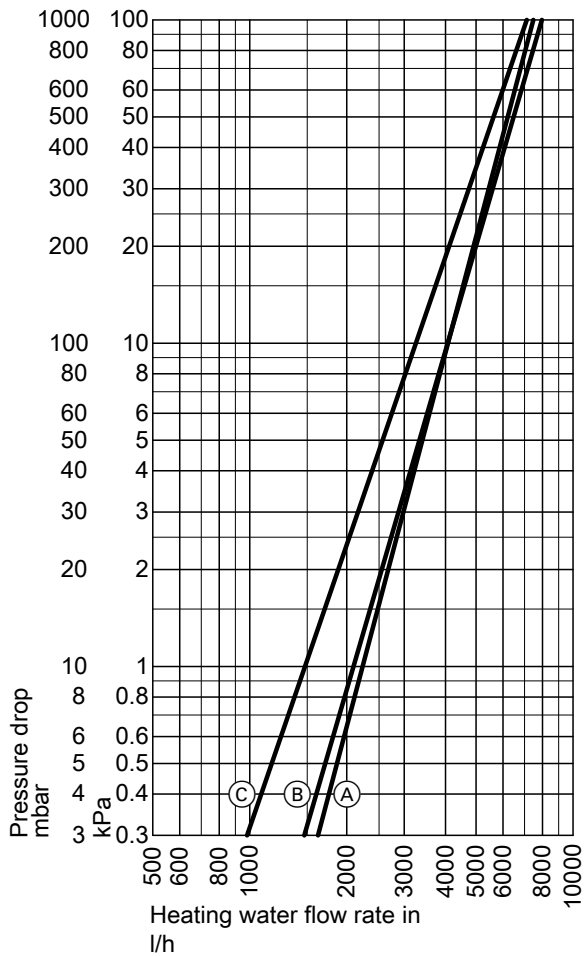

- (A) Cylinder capacity 300 l
- (B) Cylinder capacity 390 l
- (C) Cylinder capacity 500 l

Immersion heater EHE

Part no. Z012684

For installation in the connector in the **upper** part of the Vitocell 100-V/100-W, type CVWA/CVWB with cylinder volume of **300 l/390 l/500 l**

- Use the immersion heater only with soft to medium hard water up to 14 °dH (hardness level 2, up to 2.5 mol/m³)
- The heating output can be selected: 2, 4 or 6 kW

Components:

- High limit temperature cut-out device
- Temperature controller

Note

- A contactor relay, part no. 7814681, is required to control the immersion heater via the heat pump.
- The immersion heater is not intended for operation with 230 V~. If no 400 V connection is available, use commercially available immersion heaters.

Specification

Output	kW	2	4	6
Rated voltage		3/N/PE 400 V/50 Hz		
IP rating		IP 45	IP 45	IP 45
Rated current	A	8.7	8.7	8.7
Heat-up time from 10 to 60 °C				
– Cylinder volume 300 l	h	2.90	1.45	1.00
– Cylinder volume 390 l	h	3.74	1.87	1.25
– Cylinder volume 500 l	h	3.86	1.93	1.29
Content that can be heated by the immersion heater				
– Cylinder volume 300 l	l	101	101	101
– Cylinder volume 390 l	l	129	129	129
– Cylinder volume 500 l	l	133	133	133

Installation accessories (cont.)

Immersion heater EHE

■ **Part no. Z021936:**

For installation in the flanged aperture on the **lower** part of the 100-W. type CVWB with cylinder volume of **300 l**

■ **Part no. Z021937:**

For installation in the connector in the **lower** part of the 100-W. type CVWA with cylinder volume of **390 l** and **500 l**

- Use the immersion heater only with soft to medium hard water with a calcium hardness up to 14 °dH (hardness level 2, up to 2.5 mol/m³)

- The heating output can be selected: 2, 4 or 6 kW

Components:

- High limit temperature cut-out device
- Temperature controller
- Flange
- Colour of flange cover: Vitopearlwhite
- Gasket

Note

- A contactor relay, part no. 7814681, is required for switching the immersion heater via the heat pump.
- The immersion heaters are not designed for 230 V~ operation. If no 400 V connection is available, use commercially available immersion heaters.

Specification

Output	kW	2	4	6
Rated voltage		3/N/PE 400 V/50 Hz		
IP rating		IP 45	IP 45	IP 45
Rated current	A	8.7	8.7	8.7
Heat-up time from 10 to 60 °C				
– Cylinder volume 300 l	h	6.80	3.40	2.30
– Cylinder volume 390 l	h	8.73	4.36	2.91
– Cylinder volume 500 l	h	10.82	5.41	3.61
Content that can be heated by the immersion heater				
– Cylinder volume 300 l	l	236	236	236
– Cylinder volume 390 l	l	301	301	301
– Cylinder volume 500 l	l	373	373	373

Solar heat exchanger set

Part no. 7186663

For connecting the solar collectors to the DHW cylinder (390 and 500 l capacity)

Suitable for systems to DIN 4753. Up to a total water hardness of 20 °dH (3.6 mol/m³)

Max. collector surface area that can be connected:

- 11.5 m² flat-plate collectors
- 6 m² tube collectors

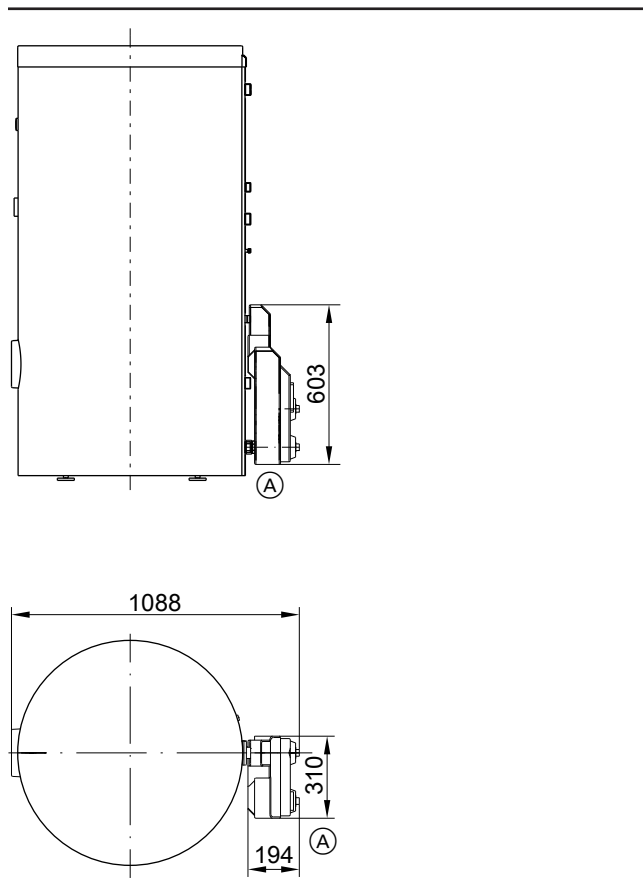

Ⓐ Solar heat exchanger set

Installation accessories (cont.)

Specification

Permissible temperatures	
Solar side	140 °C
Heating water side	110 °C
DHW side	
– For boiler operation	95 °C
– For solar operation	60 °C
Permissible operating pressure	
Solar side, heating and DHW side	10 bar (1.0 MPa)
Test pressure	
Solar side, heating and DHW side	13 bar (1.3 MPa)
Minimum wall clearance	
For installation of the solar heat exchanger set	350 mm
Circulation pump	
Power supply	230 V/50 Hz
IP rating	IP 42

Impressed current anode

Part no. Z004247

- Maintenance-free
- For installation in the Vitocell 100-V/100-W, type CVWA/CVWB in place of the protective magnesium anode supplied

6.2 DHW heating with Vitocell 100-W, type CVAB (300 l)

For Vitocal 150-A

Vitocell 100-W, type CVAB, Vitopearlwhite

Part no. Z021912

Observe the information on sizing DHW cylinders: See page 90 onwards.

Sizing entry points

The actual dimensions of the DHW cylinder may vary slightly due to manufacturing tolerances.

Information on continuous output

When designing systems with the specified or calculated continuous output, allow for a matching circulation pump. The stated continuous output is achieved only if the heat generator's rated heating output is \geq continuous output.

Specification

Type		CVAB	CVA	CVAA	
Cylinder capacity	l	300	500	750	950
(AT: Actual water capacity)					
Heating water capacity	l	10.0	12.5	29.7	33.1
Gross volume	l	310.0	512.5	779.7	983.1
DIN registration number		Applied for	9W241/11–13 MC/E		
Continuous output at heating water flow rate stated below					
– For DHW heating from 10 to 45 °C and following heating water flow temperatures					
90 °C	kW	53	70	109	116
	l/h	1302	1720	2670	2861
80 °C	kW	44	58	91	98
	l/h	1081	1425	2236	2398
70 °C	kW	33	45	73	78
	l/h	811	1106	1794	1926
60 °C	kW	23	32	54	58
	l/h	565	786	1332	1433
50 °C	kW	18	24	33	35
	l/h	442	589	805	869
– For DHW heating from 10 to 60 °C and following heating water flow temperatures					
90 °C	kW	45	53	94	101
	l/h	774	911	1613	1732
80 °C	kW	34	44	75	80
	l/h	584	756	1284	1381
70 °C	kW	23	33	54	58
	l/h	395	567	923	995

Installation accessories (cont.)

Type		CVAB	CVA	CVAA	
Cylinder capacity (AT: Actual water capacity)	l	300	500	750	950
Heating water flow rate for the stated continuous outputs	m ³ /h	3.0	3.0	3.0	3.0
Standby heat loss	kWh/24 h	1.65	1.95	2.28	2.48
Permissible temperatures					
– Heating water side	°C	160	160	160	160
– DHW side	°C	95	95	95	95
Permissible operating pressure					
– Heating water side	bar	25	25	25	25
	MPa	2.5	2.5	2.5	2.5
– DHW side	bar	10	10	10	10
	MPa	1.0	1.0	1.0	1.0
Dimensions					
Length a (∅)					
– Incl. thermal insulation	mm	668	859	1062	1062
– Excl. thermal insulation	mm	—	650	790	790
Width b					
– Incl. thermal insulation	mm	706	923	1110	1110
– Excl. thermal insulation	mm	—	837	1005	1005
Height c					
– Incl. thermal insulation	mm	1687	1948	1897	2197
– Excl. thermal insulation	mm	—	1844	1817	2123
Height when tilted					
– Incl. thermal insulation	mm	1790	—	—	—
– Excl. thermal insulation	mm	—	1860	1980	2286
Total weight incl. thermal insulation	kg	115	181	301	363
Heating surface	m ²	1.5	1.9	3.5	3.9
Connections (male thread)					
Heating water flow and return	R	1	1	1¼	1¼
Cold water, DHW	R	1	1¼	1¼	1¼
DHW circulation	R	1	1	1¼	1¼
Energy efficiency class		B	B	—	—
Colour					
– Vitocell 100-V		Vitosilver	Vitosilver or Vitopearlwhite	Vitosilver	
– Vitocell 100-W		Vitopearlwhite	—	—	

Installation accessories (cont.)

Dimensions of type CVAB, 300 l capacity

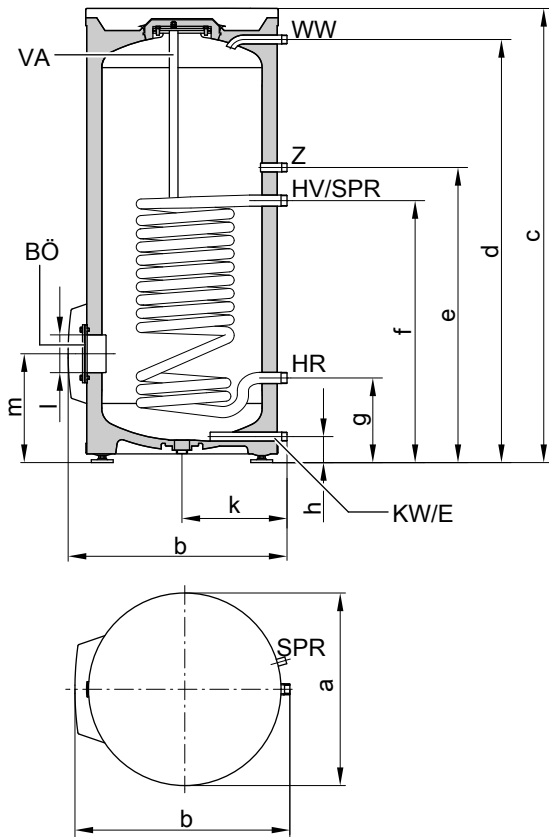

- BÖ Inspection and cleaning aperture
- E Drain
- HR Heating water return
- HV Heating water flow
- KW Cold water
- SPR Clamping device for securing immersion temperature sensors to the cylinder jacket, with fixing points for 3 immersion temperature sensors
- VA Protective magnesium anode
- WW DHW
- Z DHW circulation

Dimensions of type CVAB

Cylinder capacity		I	300
Length (∅)	a	mm	668
Width	b	mm	706
Height	c	mm	1687
	d	mm	1607
	e	mm	1122
	f	mm	882
	g	mm	267
	h	mm	83
	k	mm	362
	l	mm	∅ 100
	m	mm	340

Measurements, type CVA, 500 l capacity

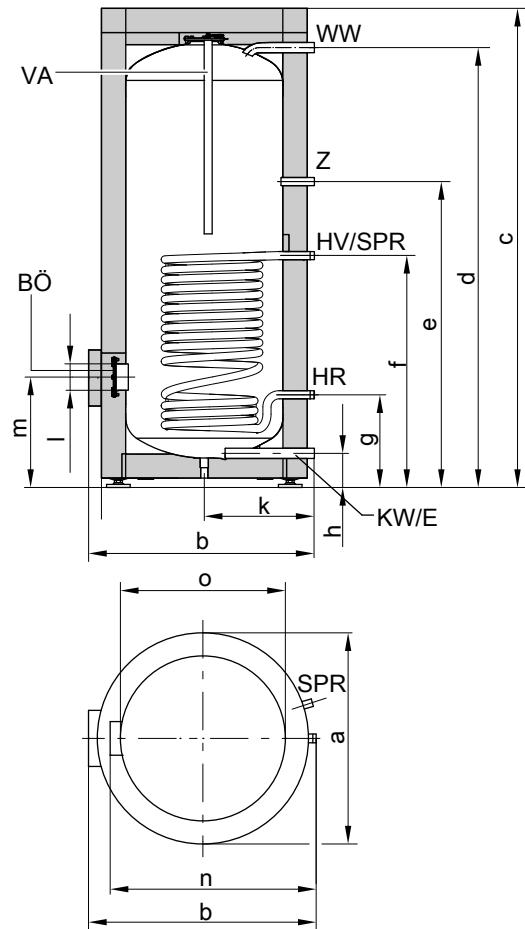

- BÖ Inspection and cleaning aperture
- E Drain
- HR Heating water return
- HV Heating water flow
- KW Cold water
- SPR Cylinder temperature sensor of the cylinder temperature controller or temperature controller (internal diameter of sensor well 16 mm)
- VA Protective magnesium anode
- WW DHW
- Z DHW circulation

Dimensions of type CVA

Cylinder capacity		I	500
Length (∅)	a	mm	859
Width	b	mm	923
Height	c	mm	1948
	d	mm	1784
	e	mm	1230
	f	mm	924
	g	mm	349
	h	mm	107
	k	mm	455
	l	mm	∅ 100
	m	mm	422
Excl. thermal insulation	n	mm	837
Excl. thermal insulation	o	mm	∅ 650

Installation accessories (cont.)

Measurements, type CVAA, 750 and 950 l capacity

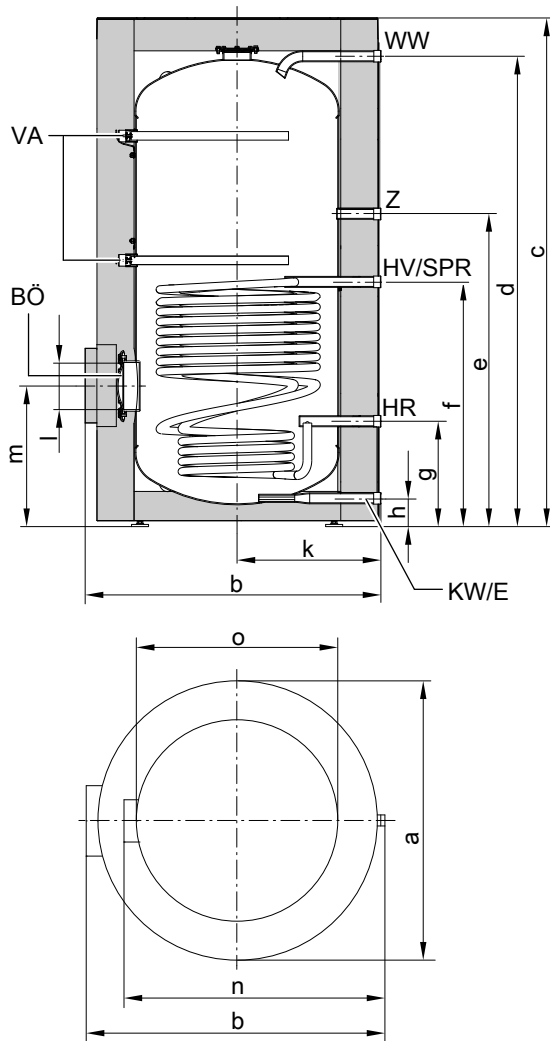

- HR Heating water return
- HV Heating water flow
- KW Cold water
- SPR Clamping device for securing immersion temperature sensors to the cylinder jacket; fixing points for 3 immersion temperature sensors per clamping device
- VA Protective magnesium anode
- WW DHW
- Z DHW circulation

Dimensions of type CVAA

Cylinder capacity		l	750	950
Length (∅)	a	mm	1062	1062
Width	b	mm	1110	1110
Height	c	mm	1897	2197
	d	mm	1788	2094
	e	mm	1179	1283
	f	mm	916	989
	g	mm	377	369
	h	mm	79	79
	k	mm	555	555
	l	mm	∅ 180	∅ 180
	m	mm	513	502
Excl. thermal insulation	n	mm	1005	1005
Excl. thermal insulation	o	mm	∅ 790	∅ 790

- BÖ Inspection and cleaning aperture
- E Drain

Performance factor N_L to DIN 4708

Cylinder capacity	l	300	500	750	950
Performance factor N_L					
Heating water flow temperature					
90 °C		9.7	21.0	38.0	44.0
80 °C		9.3	19.0	32.0	42.0
70 °C		8.7	16.5	25.0	39.0

- The performance factor N_L depends on the cylinder storage temperature T_{cyl} .
- Cylinder storage temperature $T_{cyl} = \text{cold water inlet temperature} + 50 \text{ K} \text{ }^{+5 \text{ K}/-0 \text{ K}}$

Standard values for performance factor N_L

- $T_{cyl} = 60 \text{ °C} \rightarrow 1.0 \times N_L$
- $T_{cyl} = 55 \text{ °C} \rightarrow 0.75 \times N_L$
- $T_{cyl} = 50 \text{ °C} \rightarrow 0.55 \times N_L$
- $T_{cyl} = 45 \text{ °C} \rightarrow 0.3 \times N_L$

Peak output over 10 min, relative to performance factor N_L

Cylinder capacity	l	300	500	750	950
Peak output for heating the DHW from 10 to 45 °C					
Heating water flow temperature					
90 °C	l/10 min	407	618	850	937
80 °C	l/10 min	399	583	770	915
70 °C	l/10 min	385	540	665	875

Installation accessories (cont.)

Max. draw-off rate over 10 min., relative to performance factor N_L

Cylinder capacity	l	300	500	750	950
Max. draw-off rate for DHW heating from 10 to 45 °C, with reheating					
Heating water flow temperature					
90 °C	l/min	41	62	85	94
80 °C	l/min	40	58	77	92
70 °C	l/min	39	54	67	88

Drawable water volume

Cylinder capacity	l	300	500	750	950
Draw-off rate for cylinder volume heated to 60 °C	l/min	15	15	20	20
Drawable water volume without reheating	l	240	420	615	800
Water at $t = 60$ °C (constant)					

Heat-up time

The specified heat-up times will be achieved when the maximum continuous output of the DHW cylinder is made available at the relevant heating water flow temperature and when DHW is heated from 10 to 60 °C.

Cylinder capacity	l	300	500	750	950
Heat-up time					
Heating water flow temperature					
90 °C	min	23	28	23	35
80 °C	min	31	36	31	45
70 °C	min	45	50	45	70

Pressure drop on the DHW side

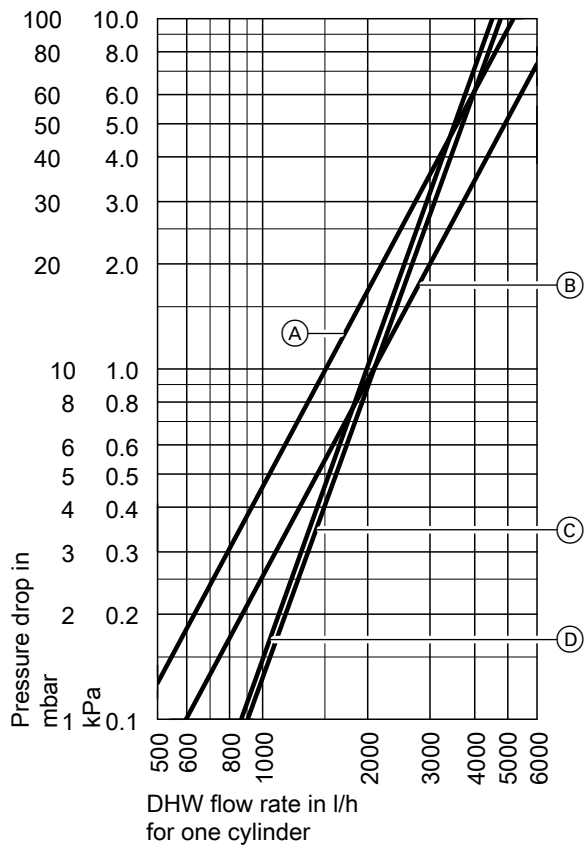

- (A) Cylinder capacity 300 l
- (B) Cylinder capacity 500 l
- (C) Cylinder capacity 750 l
- (D) Cylinder capacity 950 l

Pressure drop on the heating water side

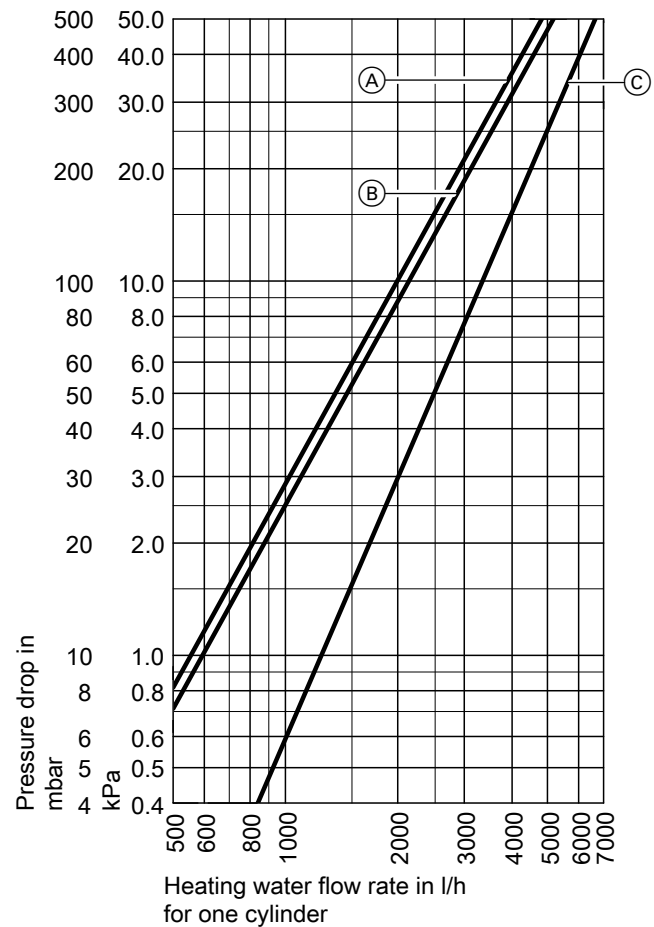

- (A) Cylinder capacity 500 l
- (B) Cylinder capacity 300 l
- (C) Cylinder capacity 750 l and 950 l

Immersion heater EHE

Part no. Z021939

- For cylinder capacity of **300 l**
- For installation into the **lower** flanged aperture
- Use the immersion heater only with soft to medium hard water with a calcium hardness up to 14 °dH (hardness level 2, up to 2.5 mol/m³)
- The heating output can be selected: 2, 4 or 6 kW

Components:

- High limit temperature cut-out device
- Temperature controller
- Flange
- Colour of flange cover: Vitoppearlwhite
- Gasket

Note

- A contactor relay, part no. 7814681, is required for switching the immersion heater via the heat pump.
- The immersion heater is not intended for operation with 230 V~. If no 400 V connection is available, use commercially available immersion heaters.

Specification

Output	kW	2	4	6
Rated voltage		3/N/PE 400 V/50 Hz		
IP rating		IP 44	IP 44	IP 44
Rated current	A	8.7	8.7	8.7
Heat-up time from 10 to 60 °C		7.4	3.7	2.5
Content that can be heated by the immersion heater	l	254	254	254

Impressed current anode

Part no. 7265008

- Maintenance free
- Install in place of the magnesium anode supplied

6.3 DHW heating with Vitocell 100-W, type CVBC, (300 I)

For Vitocal 150-A

Vitocell 100-W, type CVBC, Vitopearlwhite

Part no. Z021914

Observe the information on sizing DHW cylinders: See page 90 onwards.

Information on the upper indirect coil

The upper indirect coil is designed for connection to a heat generator.

Information on the lower indirect coil

The lower indirect coil is intended for connecting solar collectors or heat pumps.

To install the cylinder temperature sensor, use the threaded elbow with sensor well included in the standard delivery.

Information on continuous output

When designing systems with the specified or calculated continuous output, allow for a matching circulation pump. The stated continuous output is achieved only if the heat generator's rated heating output is \geq continuous output.

Sizing entry points

The actual dimensions of the DHW cylinder may vary slightly due to manufacturing tolerances.

Specification

Type	CVBC		CVB		CVB		CVBB		CVBB		
Cylinder capacity (AT: Actual water capacity)	300		400		500		750		950		
Internal indirect coil	Top	Bottom	Top	Bottom	Top	Bottom	Top	Bottom	Top	Bottom	
Heating water capacity	6	10	6.5	10.5	9	12.5	13.8	29.7	18.6	33.1	
Gross volume	316	316	417	417	521.5	521.5	795.5	795.5	1001.7	1001.7	
DIN registration no.	Applied for		9W242/11-13 MC/E				Applied for				
Continuous output at heating water flow rate stated below											
– For DHW heating from 10 to 45 °C and following heating water flow temperatures											
90 °C	kW	31	53	42	63	47	70	76	114	90	122
	l/h	761	1302	1032	1548	1154	1720	1866	2790	2221	2995
80 °C	kW	26	44	33	52	40	58	63	94	75	101
	l/h	638	1081	811	1278	982	1425	1546	2311	1840	2482
70 °C	kW	20	33	25	39	30	45	49	73	58	78
	l/h	491	811	614	958	737	1106	1200	1794	1428	1926
60 °C	kW	15	23	17	27	22	32	35	52	41	56
	l/h	368	565	418	663	540	786	853	1275	1015	1369
50 °C	kW	11	18	10	13	16	24	26	39	31	42
	l/h	270	442	246	319	393	589	639	955	760	1026
– For DHW heating from 10 to 60 °C and following heating water flow temperatures											
90 °C	kW	23	45	36	56	36	53	59	79	67	85
	l/h	395	774	619	963	619	911	1012	1359	1157	1465
80 °C	kW	20	34	27	42	30	44	49	66	56	71
	l/h	344	584	464	722	516	756	840	1128	960	1216
70 °C	kW	15	23	18	29	22	33	37	49	42	53
	l/h	258	395	310	499	378	567	630	846	720	912
Heating water flow rate for the stated continuous outputs	m ³ /h	3.0		3.0		3.0		3.0		3.0	
Max. connectible heat pump output	kW	10		12		14		21		23	
At 55 °C heating water flow temperature and 45 °C DHW temperature at the specified heating water flow rate (both internal indirect coils connected in series)											

6179959

Installation accessories (cont.)

Type		CVBC	CVB	CVB	CVBB	CVBB
Cylinder capacity (AT: Actual water capacity)	l	300	400	500	750	950
Standby heat loss	kWh/ 24 h	1.65	1.80	1.95	2.28	2.48
Standby capacity V_{aux}	l	127	167	231	365	500
Solar capacity V_{sol}	l	173	233	269	385	450
Permissible temperatures						
– Heating water side	°C	160	160	160	160	160
– DHW side	°C	95	95	95	95	95
– Solar side	°C	160	160	160	160	160
Permissible operating pressure						
– Heating water side	bar	10	10	10	10	10
	MPa	1.0	1.0	1.0	1.0	1.0
– DHW side	bar	10	10	10	10	10
	MPa	1.0	1.0	1.0	1.0	1.0
– Solar side	bar	10	10	10	10	10
	MPa	1.0	1.0	1.0	1.0	1.0
Dimensions						
Length a (∅)						
– Incl. thermal insulation	mm	668	859	859	1062	1062
– Excl. thermal insulation	mm	–	650	650	790	790
Total width b						
– Incl. thermal insulation	mm	714	923	923	1110	1110
– Excl. thermal insulation	mm	–	881	881	1005	1005
Height c						
– Incl. thermal insulation	mm	1687	1624	1948	1897	2197
– Excl. thermal insulation	mm	–	1518	1844	1797	2103
Height when tilted						
– Incl. thermal insulation	mm	1790	—	—	—	—
– Excl. thermal insulation	mm	—	1550	1860	1980	2286
Total weight incl. thermal insulation	kg	126	167	205	320	390
Total weight in operation incl. immersion heater	kg	428	569	707	1072	1342
Heating surface	m ²	0.9 1.5	1.0 1.5	1.4 1.9	1.6 3.5	2.2 3.9
Connections (male thread)						
Upper indirect coil	R	1	1	1	1	1
Lower indirect coil	R	1	1	1	1¼	1¼
Cold water, DHW	R	1	1¼	1¼	1¼	1¼
DHW circulation	R	1	1	1	1¼	1¼
Connections (female thread)						
Immersion heater	Rp	1½	1½	1½	—	—
Energy efficiency class		B	B	B	—	—
Colour						
– Vitocell 100-B		Vitosilver	Vitopearlwhite	Vitopearlwhite	Vitopearlwhite	Vitopearlwhite
– Vitocell 100-W		Vitopearlwhite	—	—	—	—

Installation accessories (cont.)

Measurements, type CVBC, 300 l capacity

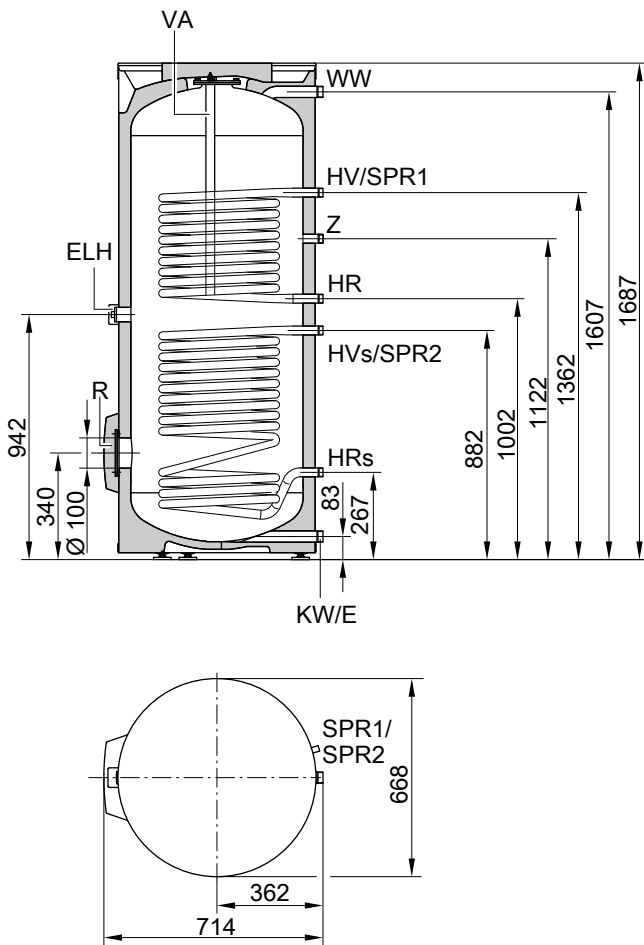

- E Drain
- ELH Immersion heater
- HR Heating water return
- HR_s Heating water return, solar thermal system
- HV Heating water flow
- HV_s Heating water flow, solar thermal system
- KW Cold water
- R Inspection and cleaning aperture with flange cover (also suitable for installation of an immersion heater)
- SPR1 Clamping device for securing immersion temperature sensors to the cylinder jacket, with fixing points for 3 immersion temperature sensors
- SPR2 Clamping device for securing immersion temperature sensors to the cylinder jacket, with fixing points for 3 immersion temperature sensors
- TH Thermometer (accessories)
- VA Protective magnesium anode
- WW DHW
- Z DHW circulation

Measurements, type CVB, 400 and 500 l capacity

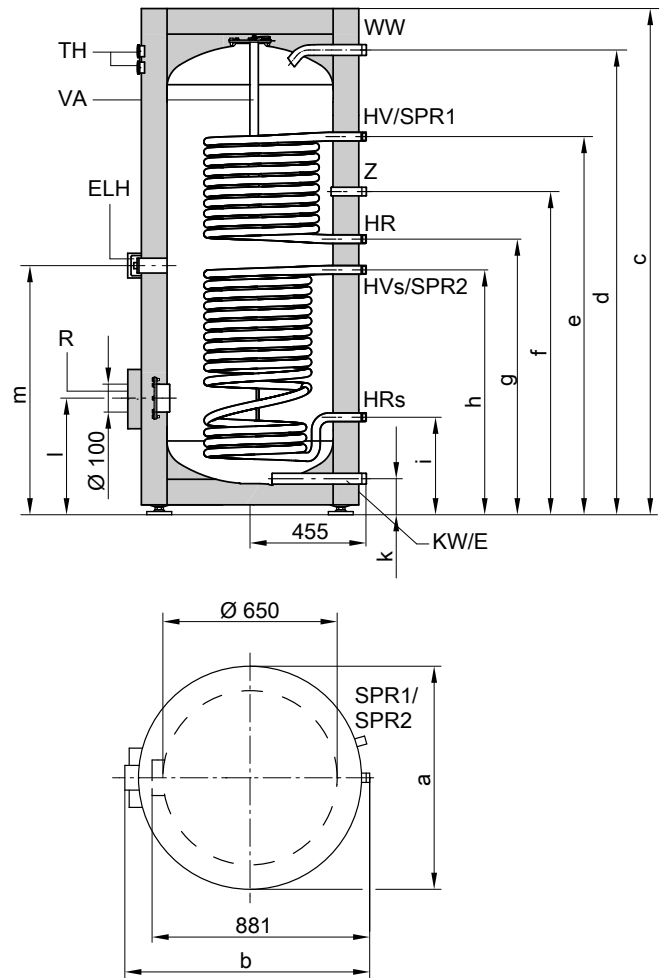

- E Drain
- ELH Connector for immersion heater
- HR Heating water return
- HR_s Heating water return, solar
- HV Heating water flow
- HV_s Heating water flow, solar
- KW Cold water
- R Inspection and cleaning aperture with flange cover (also suitable for installation of an immersion heater)
- SPR1 Cylinder temperature sensor for cylinder temperature controller (internal diameter 16 mm)
- SPR2 Temperature sensors/thermometers (internal diameter 16 mm)
- TH Thermometer (accessories)
- VA Protective magnesium anode
- WW DHW
- Z DHW circulation

Installation accessories (cont.)

Dimensions of type CVB

Cylinder capacity	l	400	500
a	mm	∅ 859	∅ 859
b	mm	923	923
c	mm	1624	1948
d	mm	1458	1784
e	mm	1204	1444
f	mm	1044	1230
g	mm	924	1044
h	mm	804	924
i	mm	349	349
k	mm	107	107
l	mm	422	422
m	mm	864	984

Measurements, type CVBB, 750 and 950 l capacity

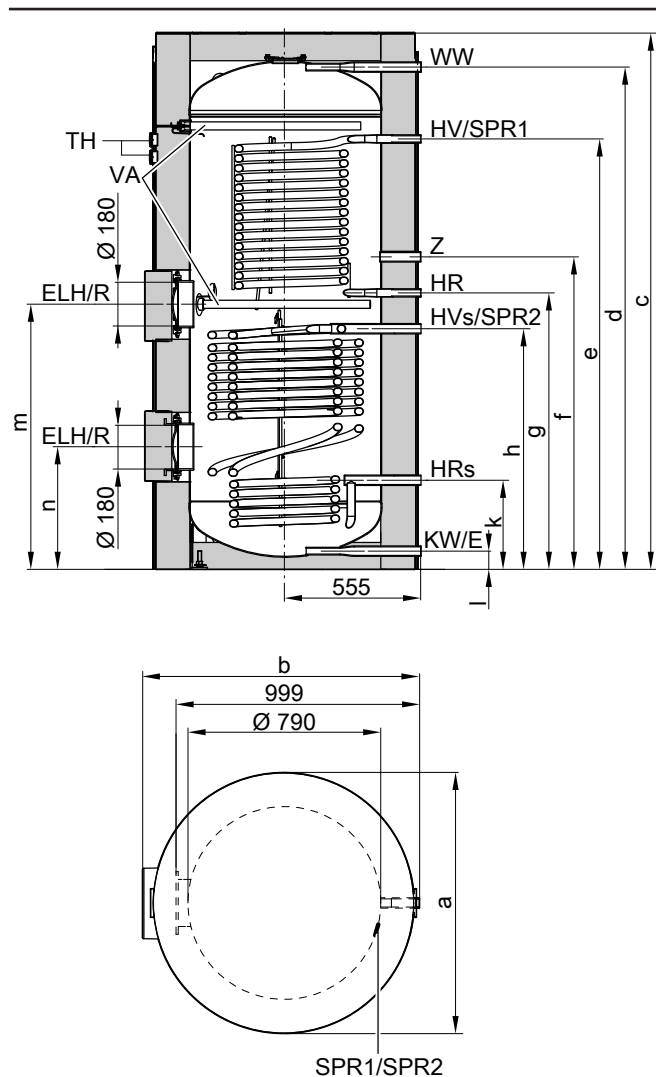

HR	Heating water return
HR _s	Heating water return, solar thermal system
HV	Heating water flow
HV _s	Heating water flow, solar thermal system
KW	Cold water
R	Inspection and cleaning aperture with flange cover
SPR1	Clamping device for securing immersion temperature sensors to the cylinder jacket, with fixing points for 3 immersion temperature sensors
SPR2	Clamping device for securing immersion temperature sensors to the cylinder jacket, with fixing points for 3 immersion temperature sensors
TH	Thermometer (accessories)
VA	Protective magnesium anode
WW	DHW
Z	DHW circulation

Dimensions of type CVBB

Cylinder capacity	l	750	950
a	mm	1062	1062
b	mm	1110	1110
c	mm	1897	2197
d	mm	1749	2054
e	mm	1464	1760
f	mm	1175	1278
g	mm	1044	1130
h	mm	912	983
k	mm	373	363
l	mm	74	73
m	mm	975	1084
n	mm	509	501

Cylinder temperature sensor for solar operation

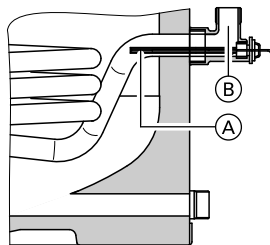

Arrangement of cylinder temperature sensor in the heating water return HR_s

- (A) Cylinder temperature sensor (standard delivery of solar control unit)
- (B) Threaded elbow with sensor well (standard delivery, internal diameter 6.5 mm)

E Drain
ELH Immersion heater or heating lance

Installation accessories (cont.)

Performance factor N_L to DIN 4708, upper internal indirect coil

Cylinder capacity	l	300	400	500	750 ^{*7}	950 ^{*7}
Performance factor N_L						
Heating water flow temperature						
90 °C		1.6	3.0	6.0	8.0	11.0
80 °C		1.5	3.0	6.0	8.0	11.0
70 °C		1.4	2.5	5.0	7.0	10.0

- The performance factor N_L changes in line with the cylinder storage temperature T_{cyl} .
- Cylinder storage temperature T_{cyl} = cold water inlet temperature + 50 K ^{+5 K/-0 K}

- $T_{cyl} = 50\text{ °C} \rightarrow 0.55 \times N_L$
- $T_{cyl} = 45\text{ °C} \rightarrow 0.3 \times N_L$

Standard values for performance factor N_L

- $T_{cyl} = 60\text{ °C} \rightarrow 1.0 \times N_L$
- $T_{cyl} = 55\text{ °C} \rightarrow 0.75 \times N_L$

Peak output over 10 min, relative to performance factor N_L

Cylinder capacity	l	300	400	500	750 ^{*7}	950 ^{*7}
Peak output for heating the DHW from 10 to 45 °C						
Heating water flow temperature						
90 °C	l/10 min	173	230	319	438	600
80 °C	l/10 min	168	230	319	438	600
70 °C	l/10 min	164	210	299	400	550

Max. draw-off rate over 10 min., relative to performance factor N_L

Cylinder capacity	l	300	400	500	750 ^{*7}	950 ^{*7}
Max. draw-off rate for DHW heating from 10 to 45 °C, with reheating						
Heating water flow temperature						
90 °C	l/min	17	23	32	44	60
80 °C	l/min	17	23	32	44	60
70 °C	l/min	16	21	30	40	55

Drawable water volume

Cylinder capacity	l	300	400	500	750 ^{*7}	950 ^{*7}
Draw-off rate for cylinder volume heated to 60 °C						
	l/min	15	15	15	15	15
Drawable water volume without reheating						
	l	110	120	220	330	420
Water at $t = 60\text{ °C}$ (constant)						

Heat-up time

The specified heat-up times will be achieved when the maximum continuous output of the DHW cylinder is made available at the relevant heating water flow temperature and when DHW is heated from 10 to 60 °C.

Cylinder capacity	l	300	400	500	750 ^{*7}	950 ^{*7}
Heat-up time						
Heating water flow temperature						
90 °C	min	16	17	19	17	18
80 °C	min	22	23	24	21	22
70 °C	min	30	36	37	26	28

Pressure drop on the DHW side

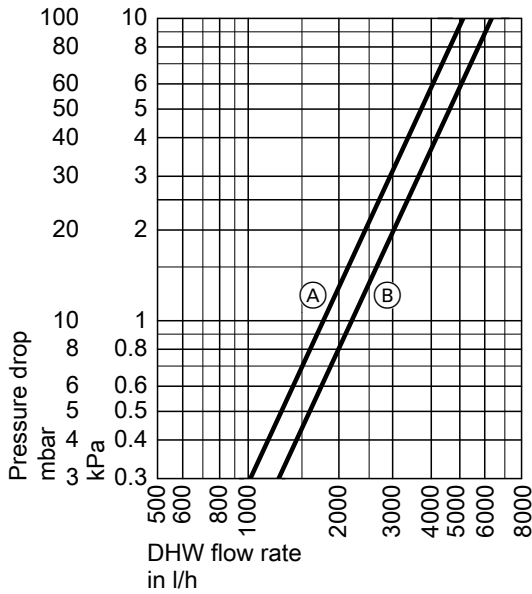

- (A) Cylinder capacity 300 l
- (B) Cylinder capacity 400 and 500 l

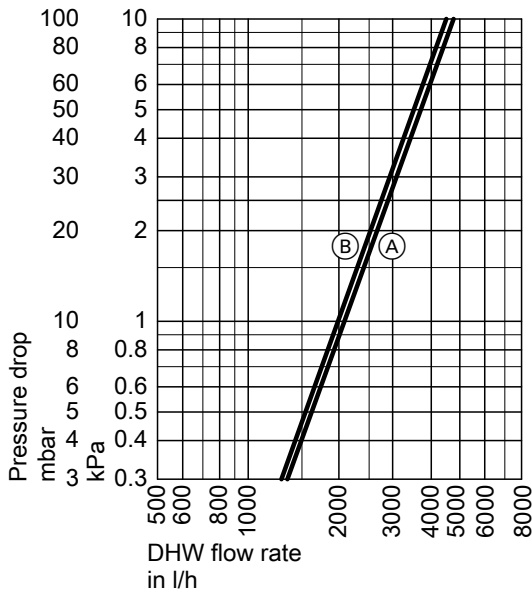

- (A) Cylinder capacity 750 l
- (B) Cylinder capacity 950 l

Pressure drop on the heating water side

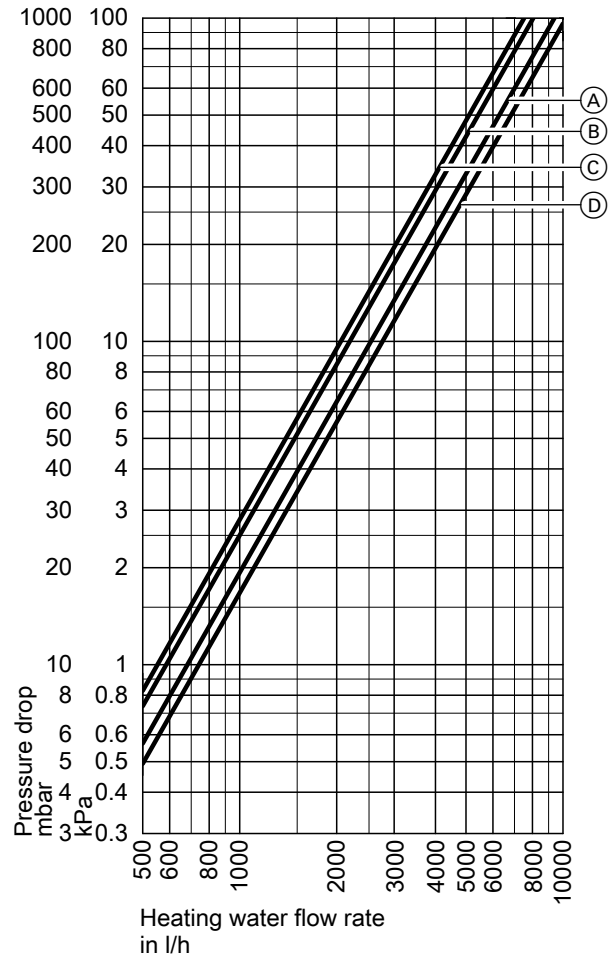

- (A) Cylinder capacity 300 l (upper indirect coil)
- (B) Cylinder capacity 300 l (lower indirect coil)
- (C) Cylinder capacity 400 and 500 l (upper indirect coil)
- (D) Cylinder capacity 500 l (lower indirect coil)
- (D) Cylinder capacity 400 l (lower indirect coil)

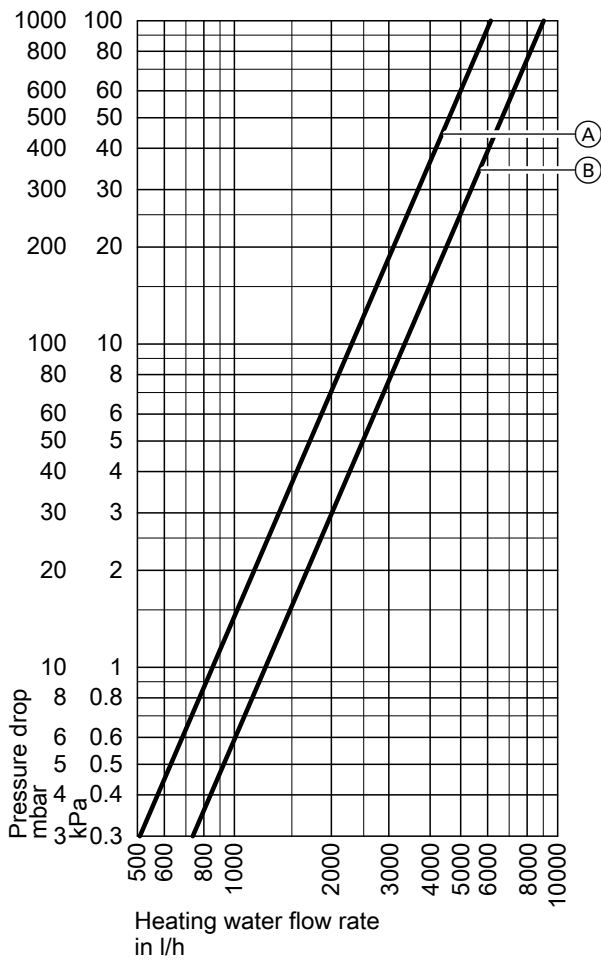

- (A) Cylinder capacity 750 and 950 l (upper indirect coil)
- (B) Cylinder capacity 750 and 950 l (lower indirect coil)

Immersion heater EHE

Part no. Z021939

- For cylinder capacity of **300 l**
- For installation into the **lower** flanged aperture
- Use the immersion heater only with soft to medium hard water with a calcium hardness up to 14 °dH (hardness level 2, up to 2.5 mol/m³)
- The heating output can be selected: 2, 4 or 6 kW

Components:

- High limit temperature cut-out device
- Temperature controller
- Flange
- Colour of flange cover: Vitopearlwhite
- Gasket

Note

- A contactor relay, part no. 7814681, is required for switching the immersion heater via the heat pump.
- The immersion heater is not intended for operation with 230 V~. If no 400 V connection is available, use commercially available immersion heaters.

Specification

Output	kW	2	4	6
Rated voltage		3/N/PE 400 V/50 Hz		
IP rating		IP 44	IP 44	IP 44
Rated current	A	8.7	8.7	8.7
Heat-up time from 10 to 60 °C		7.4	3.7	2.5
Content that can be heated by the immersion heater	l	254	254	254

Impressed current anode

Part no. 7265008

- Maintenance free
- Install in place of the magnesium anode supplied

Design information

7.1 Power supply and tariffs

According to current Federal tariffs [Germany], the electrical demand for heat pumps is considered domestic usage. Where heat pumps are used to heat buildings, the local power supply company must first give permission [check with your local power supply company]. Check the connection conditions specified by your local power supply utility for the stated equipment details. It is crucial to establish whether a mono-mode and/or mono-energetic heat pump operation is feasible in the supply area.

It is also important to obtain information about standing charges and energy tariffs, about the options for utilising off-peak electricity during the night and about any power-off periods.

Address any questions relating to these issues to your customer's local power supply utility.

Application procedure

The following details are required to assess the effect of the heat pump operation on the grid of your local power supply utility:

- User address
- Location where the heat pump is to be used
- Type of demand in accordance with general tariffs (domestic, agricultural, commercial, professional and other use)
- Intended heat pump operating mode
- Heat pump manufacturer
- Type of heat pump
- Connected load in kW (from rated voltage and rated current)
- Max. starting current in A
- Max. heat load of the building in kW

7.2 Siting the outdoor unit

The outdoor units are painted with UV resistant paint.

Note

When the heat pump is installed in a corrosive atmosphere, the ambient air and the air drawn in by the heat pump contain substances such as ammonia, sulphur, chloride, salts, etc. These substances can cause internal and external damage to the heat pump.

Viessmann heat pumps for outdoor installation are designed for operation in moderately aggressive atmospheres. This makes them suitable for installation in urban and industrial environments as well as in coastal areas.

Higher corrosive loads can cause visual defects on the casing or affect operation. The service life of the heat pump may be shortened.

Requirements of the installation location

- Maximum geographical height of the installation location: 1500 m above sea level
- Select a site with good air circulation, so that the cooled air can dissipate and be replaced by warm air.
- Do not install in recesses or between walls. This could result in an "air short circuit" between the air being discharged and the air being drawn in.
 - An "air short circuit" during **heating mode** will result in the cooled, discharged air re-entering the unit. This can result in reduced heat pump efficiency and defrosting problems.
 - An air short circuit during **cooling mode** will result in the heated, discharged air re-entering the unit. This can lead to high pressure faults.
- If siting the appliance in a location that is exposed to wind, ensure that the wind cannot influence the fan area. Strong wind can have a negative influence on the air flow through the evaporator.
- Select an installation location where the evaporator cannot be blocked by leaves, snow, etc.
- Select the installation location giving due consideration to the physical laws concerning the propagation and reflection of sound.
- Do not install above cellar shafts or floor troughs.
- Do not install near windows or bedrooms.
- To avoid increased wind loads, maintain 1 m distance from building edges and corners.
- Maintain a clearance of at least 3 m to pathways, downpipes or sealed surfaces. The cooled air in the discharge area creates a risk of ice forming when outside temperatures are below 10 °C.
- The installation location must be easily accessible, for example for maintenance work: See "Minimum clearances".

Additional requirements for flat roof installation:

- Never install the outdoor unit on a flat roof immediately next to or above living rooms or bedrooms.
- Do not locate in front of windows, or keep a distance of 1 m from them.
- Because of the increased wind loads, keep a distance of 5 m from building edges.

Siting

- In accordance with EN 378-3:2016, the outdoor unit should only be installed in the open air.
- The refrigerant circuit in the outdoor unit contains easily flammable refrigerant in safety group A3 according to ANSI/ASHRAE Standard 34.
Therefore a safety zone is defined in the immediate vicinity of the outdoor unit, in which special requirements apply: See chapter "Safety zone".
- Observe the information regarding noise levels.
Sound emission regulations (TA-Lärm in Germany) must be observed.
- When siting the heat pump, always take into account the distances to neighbouring properties in accordance with local building regulations.
- Do not install with the discharge side facing towards the house wall or the main wind direction.
- During defrosting, cool vapour escapes from the outdoor unit air discharge vents. This vapour discharge must be taken into consideration during installation (choosing the installation location, orientation of the heat pump).
- Provide wall outlets and protective conduits for the hydraulic connection lines and electrical connecting cables without moulded parts or changes of direction.
All wall outlets must be made **gas-tight**. This also includes wall outlets that **lie below ground level in the safety zone**.
- Provide equipment for the protection of the outdoor unit against mechanical damage e.g. Impact damage from footballs.
- Take environmental and weather influences into account in the selection of the installation location, e.g. flooding, wind, snow, ice damage, etc. Install suitable protection equipment if required.

Siting in garages, multi-storey car parks and car parking areas:

- Prior to installation, it must be established for the case in question whether the installation is permissible under local garage and parking area regulations (German regulations GaStellV, GaStplVO, BetrVO).
- Provide systems with refrigerants in safety group A3 with impact protection. This impact protection must be designed so that a strike by a vehicle at the applicable maximum speed does not result in damage to the refrigerant circuit.
- Mark the outdoor unit safety zone with prohibition notices to identify ignition sources.
- Siting in underground car parks is **not** permissible.

Siting in coastal areas: Distance < 1000 m

- In coastal areas salt and sand particles in the air increase the likelihood of corrosion:
Site the heat pump where it is protected from direct onshore wind.
- If required, provide a wind break on site. Observe the minimum clearances to the heat pump: See the following chapter.

Types of installation

- Floorstanding installation with line entry above ground level
- Floorstanding installation with line entry below ground level
- Wall mounting
- Flat roof installation

Note

We only recommend installing the outdoor unit on a flat roof if installation on the floor or ground is not possible due to the site conditions.

Floorstanding installation

Particularly in adverse climatic environments (minus temperatures, snow and humidity) a distance to the substrate of at least 300 mm is required.

- Secure the outdoor unit with supports for floorstanding installation (accessories) onto a concrete foundation.
Use ground anchors with a tensile force of at least 2.5 kN to secure the support to the foundation.
- If the supports cannot be used, site the outdoor unit on a concrete foundation ≥ 250 mm high using anti-vibration feet (accessories).

If the outdoor unit is installed under a snow-free awning, (e.g. a carport) a lower plinth can be used.

- Take into account the weight of the outdoor unit: See chapter "Weight of outdoor units".

Wall mounting

- Use the wall mounting bracket set (accessories).
- The wall must meet the structural requirements.
Use suitable fixing materials, depending on the wall structure.

Flat roof installation

Note

Due to the higher static loads (roof/wind load) and the higher acoustic requirements for flat roof installation, the structural calculations and sound concept require input from specialist design engineers.

Design information (cont.)

If the outdoor unit is to be installed on a flat roof, in addition to the requirements for floor and wall installation, the following planning measures to be taken into account include:

- As the outdoor unit is located higher up when installed on a flat roof, operating noise propagation is more intense than when the unit is installed on the ground. Roof surfaces are normally more reverberant than areas on the ground. To prevent noise nuisance, install the outdoor unit at a sufficient distance from neighbouring buildings. If required, provide suitable noise reduction measures. Take into account sound reflection from the surfaces of buildings when analysing sound propagation: See technical guide.
- Provide on-site wind protection measures if required, e.g. screens, walls, etc.
- Check to ensure that the installed height of the outdoor unit does not exceed the permissible building height, e.g. as specified in outline planning restrictions.

- Provide easy, year-round access to the outdoor unit for service and maintenance. Provide sufficient maintenance areas. Install suitable protection equipment, e.g. anchorage points.
- We recommend installing the heat pump on a steel-reinforced concrete ceiling.
- Installation on flat roofs with a low weight per unit area (e.g. roofs made from timber rafters or trapezoidal sheet metal) is **not permissible**.
- With flat roof installation, considerable wind loads may occur, depending on the relevant wind zone and the height of the building. Have the substructure designed according to DIN 1991-1-4 by a specialist design engineer.
- The higher roof and wind loads must be taken into account in the structural calculations and the fixture system of the outdoor unit.

Weather influences

- Observe wind loads when installing the unit on sites exposed to the wind.
- Fit the pipework exposed to the outdoor air outside the support for floorstanding installation (accessories) with adequately thick thermal insulation in accordance with the German Buildings Energy Act (GEG): See the following table.

Pipework internal \varnothing	Min. thickness of thermal insulation layer with $\lambda = 0.035 \text{ W/(m}\cdot\text{K)}$
$\leq 22 \text{ mm}$	40 mm
$> 22 \text{ mm}$	60 mm

λ Thermal conductivity

- If a design casing for the support for floorstanding installation (accessories) is used: For pipework inside the support, use the thermal insulation supplied.
- Incorporate the outdoor unit into the lightning protection system.
- Note the heat absorbed (heating mode) and heat emitted (cooling mode) by the appliance when designing weatherproofing measures or an enclosure.

Condensate

In regions where the outside temperature is often below 0 °C, we recommend installing an electrical ribbon heater (accessories) for the condensate pan of the outdoor unit. For types ...-AF an electric ribbon heater is factory-fitted.

Floorstanding installation:

- Ensure that condensate can drain freely.
- Allow condensate to soak away into a gravel bed or into a deep seepage layer, or direct it into the waste water system: See chapter "Draining condensate via a soakaway".

Note

If refrigerant gets into the waste water system (e.g. as a result of a leak in the refrigerant circuit), there is a risk of explosion.

Therefore, only connect the condensate drain to the waste water system via a trap.

Wall mounting:

- Ensure that condensate can drain freely.
- Allow condensate to soak away into a gravel bed: See chapter "Draining condensate via a soakaway".

Flat roof installation:

- Allowing the condensate to drain freely onto the roof surface is not permissible, as this may result in the formation of layers of ice. Layers of ice on the roof may prevent further condensate from draining freely, resulting in increased roof loads.
- Use an electric ribbon heater for the condensate pipe (accessories).
- To drain the condensate, connect the condensate hose on the outdoor unit to an insulated condensate pipe. The condensate pipe is part of the standard delivery of the electric ribbon heater for the condensate pipe. If required, insert the condensate hose via a trap insert.

Structure-borne noise insulation and vibration isolation between the building and outdoor unit

- Route cables/leads between the indoor and outdoor units so they are not stressed.
- Installation only on walls with a high weight per unit area ($> 250 \text{ kg/m}^2$); in other words not on lightweight walls, roof structures, etc.
- Vibration isolation components are included in the standard delivery of the wall mounting bracket.

- Do not use additional anti-vibration mounts, springs, rubber mounts, etc.

- When installing the outdoor unit on roof surfaces, there is a risk that structure-borne noise and vibrations will be transmitted into the building.

If the outdoor unit is installed on freestanding garages, insufficient structure-borne noise insulation and vibration isolation can cause excessive noise due to resonance amplification.

See chapter "Information on reducing sound emissions" on page 85.

Design information (cont.)

Weight of outdoor units

Outdoor unit	Weight in kg
Outdoor unit 230 V~	215
Outdoor unit 400 V~	221

Safety zone

The refrigerant circuit in the outdoor unit contains easily flammable refrigerant in safety group A3 according to ISO 817 and ANSI/ASHRAE Standard 34.

Therefore a safety zone is defined in the immediate vicinity of the outdoor unit, in which special requirements apply.

The following conditions must not be present or occur within the safety zone:

- Building openings, e.g. windows, doors, light wells, flat roof windows, etc.
- Outdoor air and exhaust air apertures from ventilation and air conditioning systems
- Property boundaries, neighbouring properties, footpaths and driveways
- Pump shafts, inlets to waste water systems, downpipes and waste water shafts, etc.
- Other slopes, troughs, depressions, shafts
- Electrical house supply connections
- Electrical systems, sockets, lamps, light switches
- Snowfall from roofs

Do not introduce ignition sources into the safety zone:

- Naked flames or burner gauze assemblies
- Grills
- Tools that generate sparks
- Electrical devices not free of ignition sources, mobile devices with integrated batteries (e.g. mobile phones, fitness watches, etc.)
- Objects with temperatures above 360 °C

Note

The particular safety zone is dependent on the surroundings of the outdoor unit.

- The safety zones below are shown with floorstanding installation. These safety zones also apply to other types of installation.
- In the case of wall installation, the requirements listed above also apply to the area **below** the outdoor unit, down to the ground.

Freestanding positioning of the outdoor unit

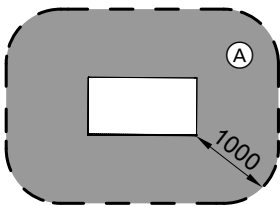

(A) Safety zone

Siting the outdoor unit in front of an external wall

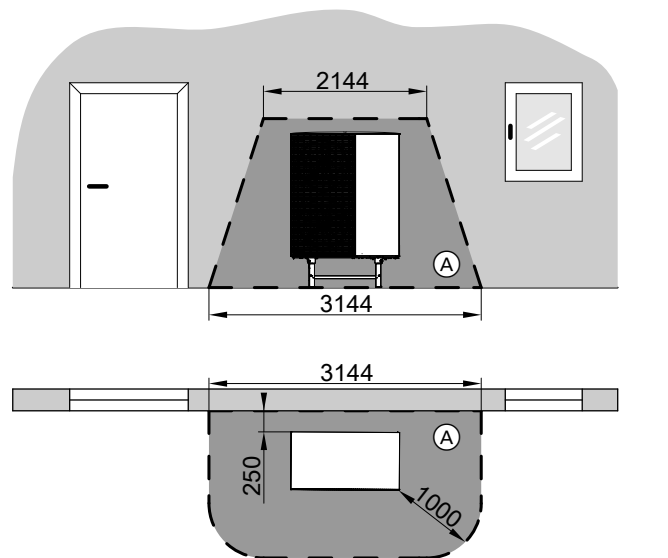

(A) Safety zone

Corner positioning of the outdoor unit, right

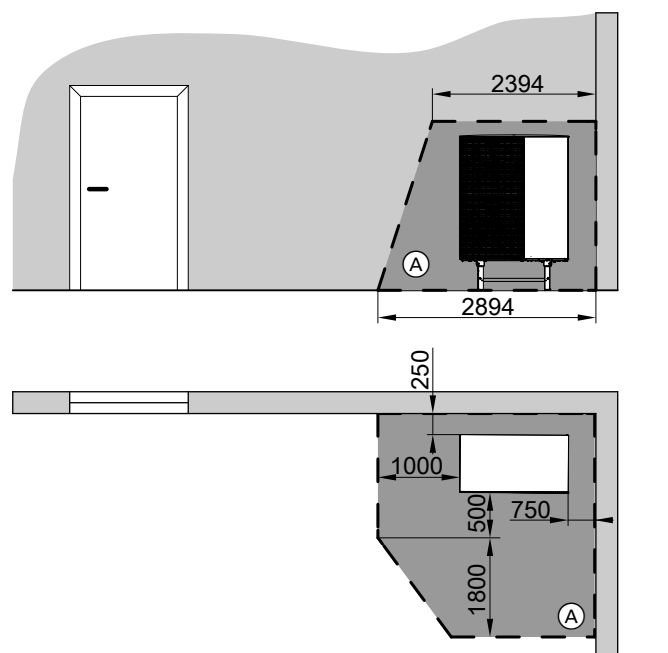

(A) Safety zone

Design information (cont.)

Corner positioning of the outdoor unit, left

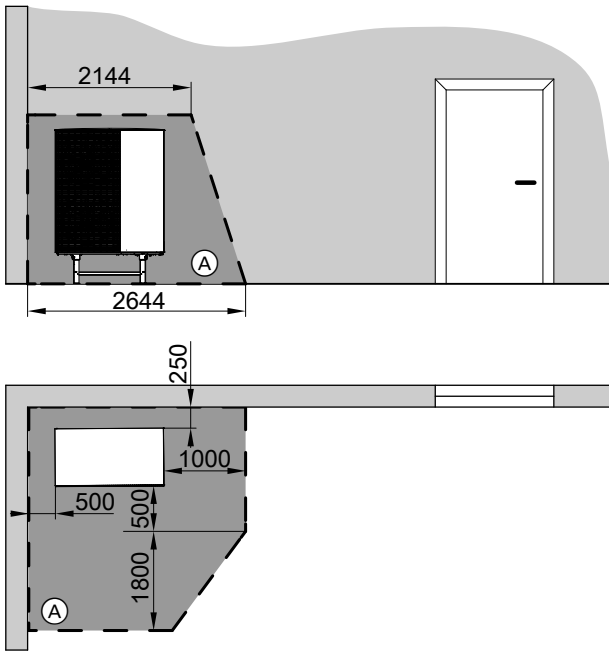

(A) Safety zone

Outdoor unit minimum clearances

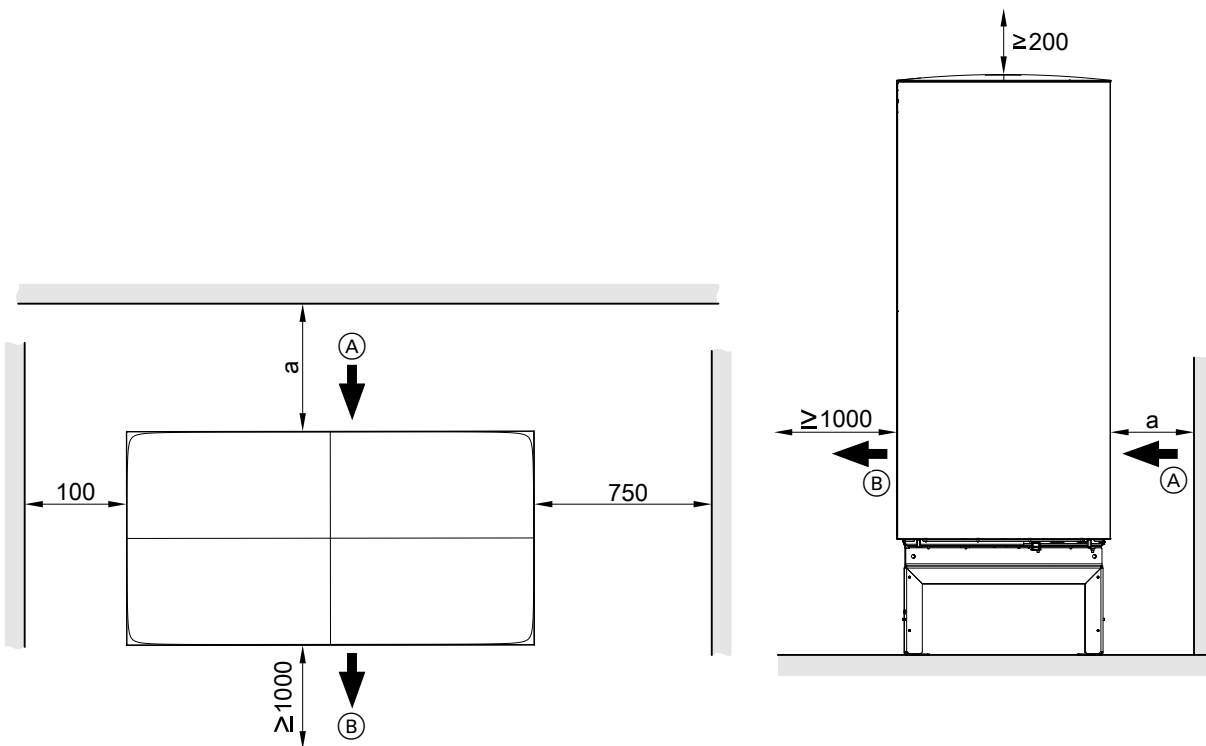

Design information (cont.)

- (A) Air intake
- (B) Air discharge
- a ■ Line entry above ground level:
 - ≥ 250 mm
- Line entry below ground level:
 - ≥ 450 mm

Foundation for installation with support for floorstanding installation (accessories)

Provide 2 horizontal foundation strips.

- Max. tilting angle: $\pm 2^\circ$

We recommend the construction of concrete foundations in accordance with the following diagram. The stated thickness of the layers represents an average value. These values should be adjusted to suit the local conditions. Observe the standard rules of building engineering.

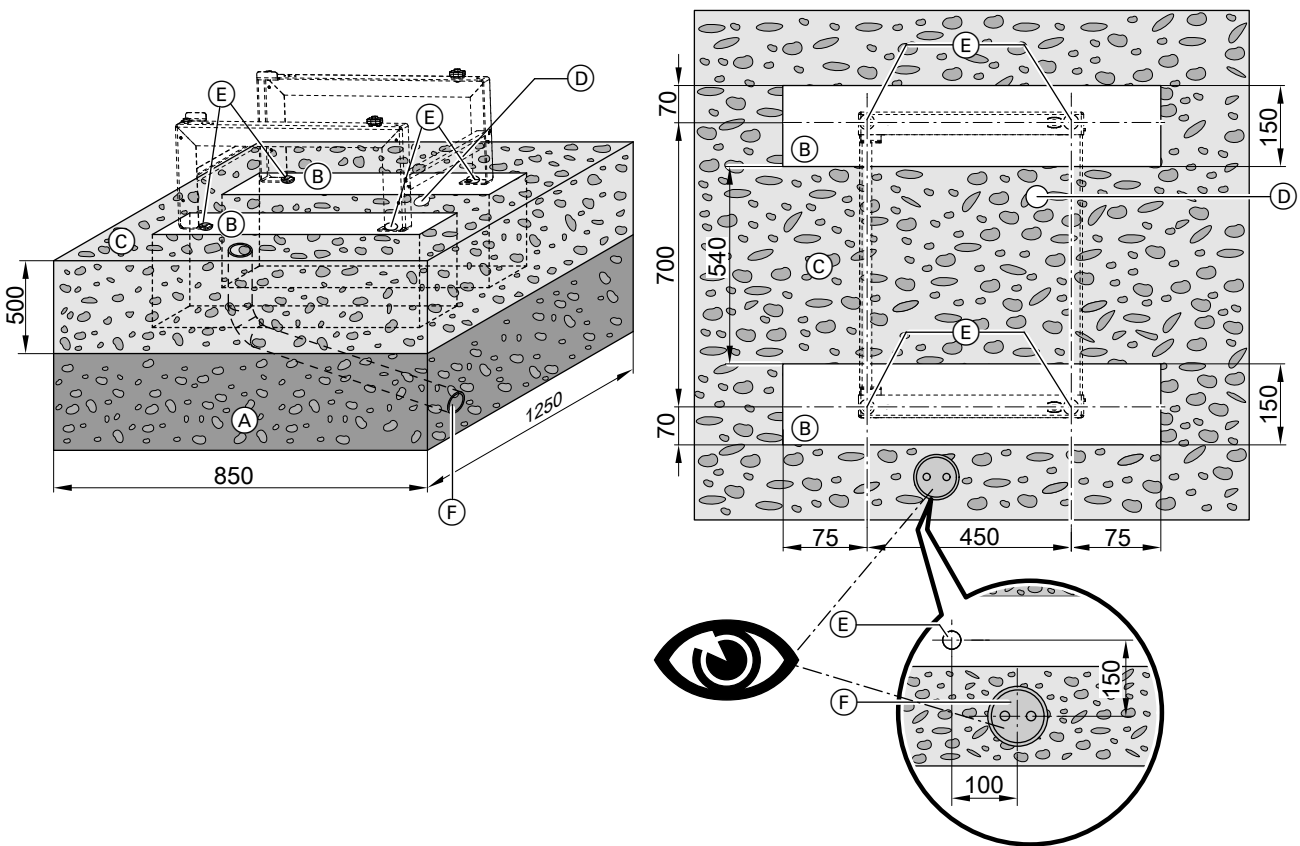

- (A) Frost protection for foundations (compacted crushed stone, e.g. 0 to 32/56 mm); thickness of layer subject to local requirements and building regulations
- (B) Foundation strip
- (C) For free drainage of condensate: Gravel bed as soakaway
- (D) Conduit (min. DN 40) for draining condensate via waste water system or seepage layer
- (E) Fixing points for support: Use ground anchors with a tensile force of at least 2.5 kN.
- (F) Only for line entry below ground level: Hydraulic connection set (accessories)

Note

So that the floorstanding installation connection set (accessories) can be used, align both lines of the hydraulic connection set flush with and parallel to the edge of the foundation: See previous illustration.

Foundation for installation with anti-vibration feet (accessories)

Provide 2 horizontal foundation strips.

- Max. tilting angle: $\pm 2^\circ$

We recommend the construction of concrete foundations in accordance with the following diagram. The stated thickness of the layers represents an average value. These values should be adjusted to suit the local conditions. Observe the standard rules of building engineering.

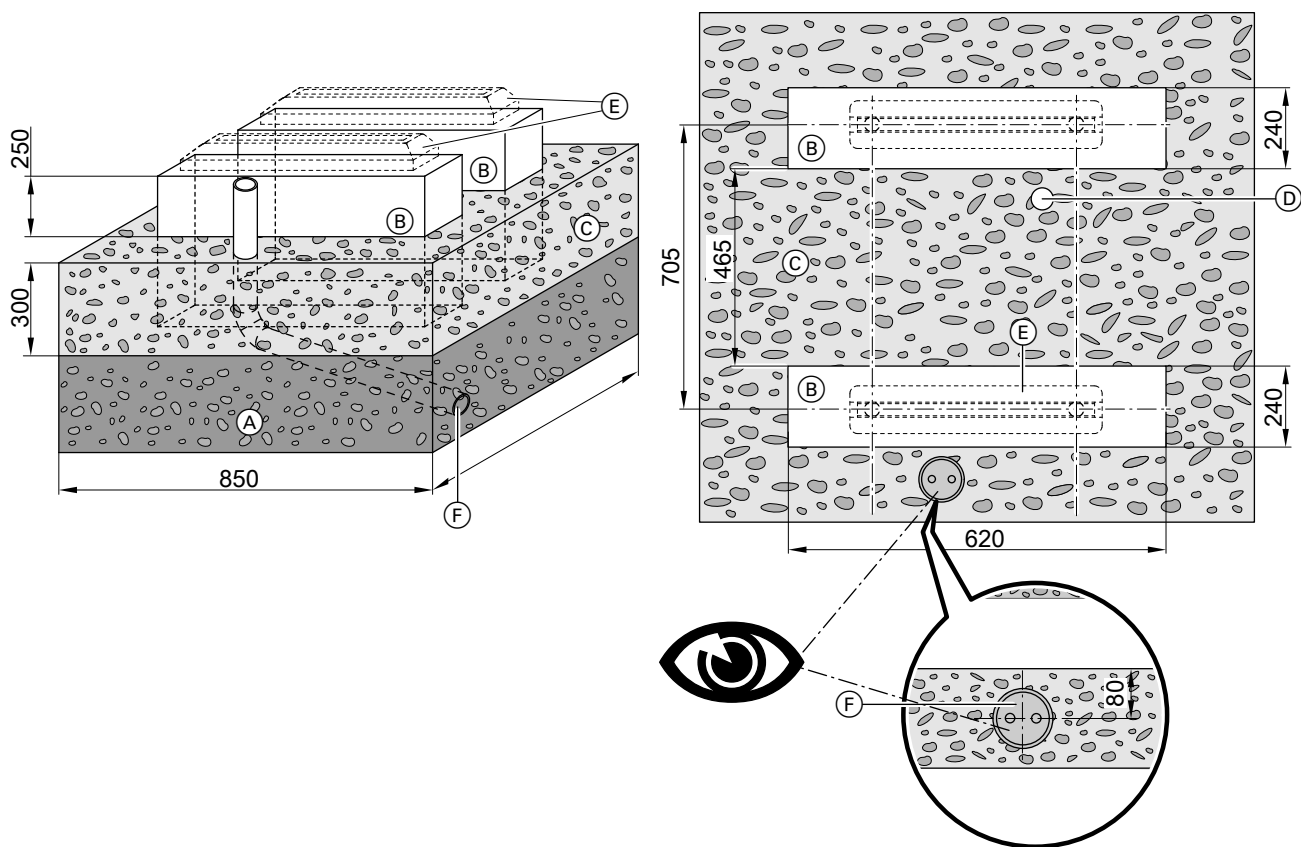

- (A) Frost protection for foundations (compacted crushed stone, e.g. 0 to 32/56 mm); thickness of layer subject to local requirements and building regulations
- (B) Foundation strip
- (C) For free drainage of condensate: Gravel bed as soakaway

- (D) Conduit (min. DN 40) for draining condensate via waste water system or seepage layer
- (E) Anti-vibration feet (accessories): Align the anti-vibration feet centrally on the foundation.
- (F) Only for line entry below ground level: Hydraulic connection set (accessories)

Note

So that the floorstanding installation connection set (accessories) can be used, align both lines of the hydraulic connection set flush with and parallel to the edge of the foundation: See previous illustration.

Draining condensate via a soakaway

- Allow the condensate to drain away freely **without** a drain pipe into a gravel bed beneath the outdoor unit.
Or
- Allow the condensate to drain away via a **drain pipe** into a seepage layer (only for floorstanding installation): See following diagram.

Note

To ensure correct function of the condensate drain even at low temperatures, provide a ribbon heater in the drain pipe (accessories).

Design information (cont.)

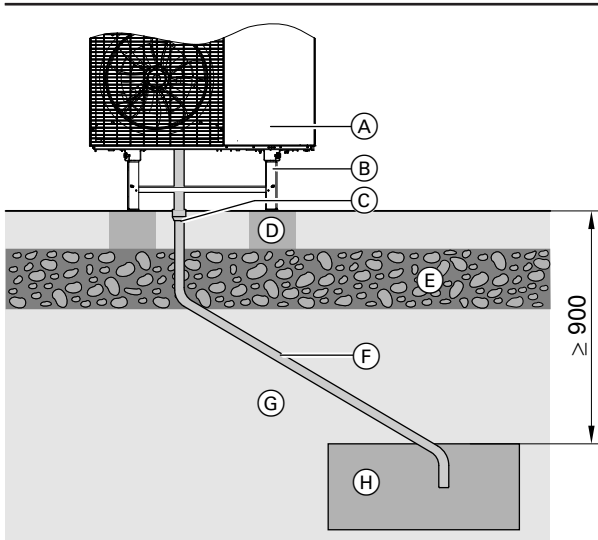

- (C) Condensate drain connector
- (D) Foundation
- (E) Frost protection (compacted crushed stone)
- (F) Drain pipe with ribbon heater (at least DN 40)
- (G) Ground
- (H) Seepage layer for removal of condensate

- (A) Outdoor unit
- (B) Support for floorstanding installation (accessories)

Draining condensate via waste water system

Note

To ensure correct function of the condensate drain even at low temperatures, provide a ribbon heater in the drain pipe (accessories).

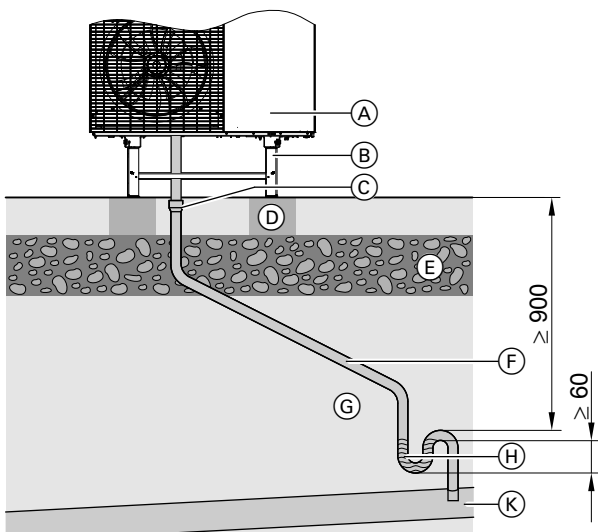

- (C) Condensate drain connector
- (D) Foundation
- (E) Frost protection (compacted crushed stone)
- (F) Drain pipe with ribbon heater (at least DN 40)
- (G) Ground
- (H) Stench trap in an area free from the risk of frost
- (K) Drain

- (A) Outdoor unit
- (B) Support for floorstanding installation (accessories)

Design information (cont.)

Floorstanding installation with support: Line entry above ground level

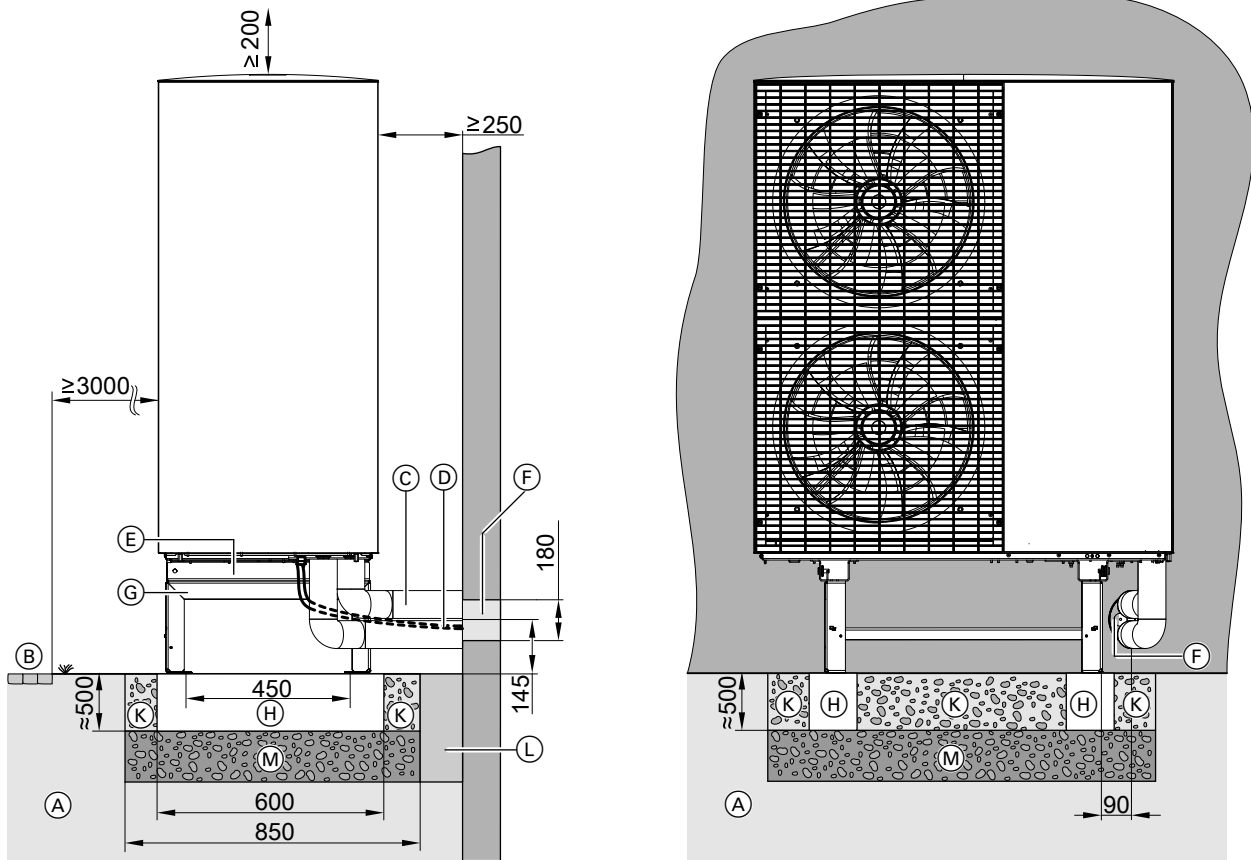

- (A) Ground
- (B) Pathway, patio
- (C) Hydraulic connection lines, indoor/outdoor unit
- (D) Indoor/outdoor unit CAN bus communication cable and outdoor unit power cable:
Route the cables free of stress.
- (E) Condensate drain in the base plate:
Do not connect anything if the condensate can drain freely.
- (F) Gas-tight wall outlet (accessories) for electrical cables and hydraulic lines
- (G) Support for floorstanding installation (accessories), illustration without design casing (accessories)
- (H) Foundation strip
- (K) For free drainage of condensate: Gravel bed as soakaway
- (L) Flexible separating layer between the foundations and the building
- (M) Frost protection for foundations (compacted crushed stone, e.g. 0 to 32/56 mm); thickness of layer subject to local requirements and building regulations

Note

- Provide thermal insulation of sufficient thickness on the pipework to the outdoor air: See table on page 68.
- Protect the pipework against damage. Avoid trip hazards.

Design information (cont.)

Floorstanding installation with support: Line entry below ground level

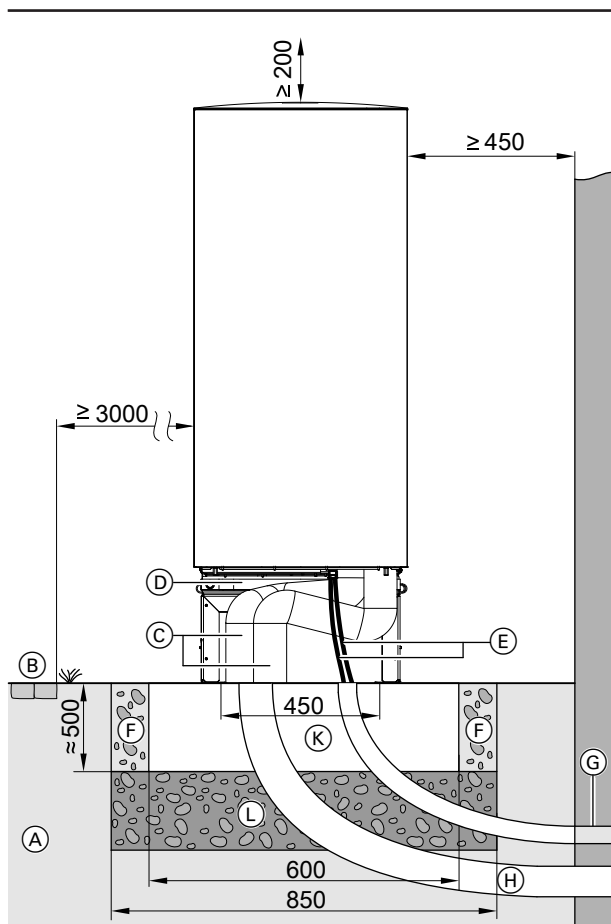

- Ⓒ Connection set, floorstanding installation (accessories)
- Ⓓ Support for floorstanding installation (accessories)
- Ⓔ Indoor/outdoor unit CAN bus communication cable and outdoor unit power cable:
Route the cables free of stress.
- Ⓕ For free drainage of condensate: Gravel bed as soakaway
- Ⓖ Gas-tight wall outlet for CAN bus communication cable, indoor/outdoor unit and outdoor unit power cable (accessories)
- Ⓗ Hydraulic connection set (accessories):
Make the wall outlet into the building gas-tight.
- Ⓚ Foundation strip
- Ⓛ Frost protection for foundations (compacted crushed stone, e.g. 0 to 32/56 mm); thickness of layer subject to local requirements and building regulations

Note

- Provide thermal insulation of sufficient thickness on the pipework to the outdoor air: See table on page 68.
- Protect the pipework against damage. Avoid trip hazards.

- Ⓐ Ground
- Ⓑ Pathway, patio

Wall mounting with bracket set for wall mounting

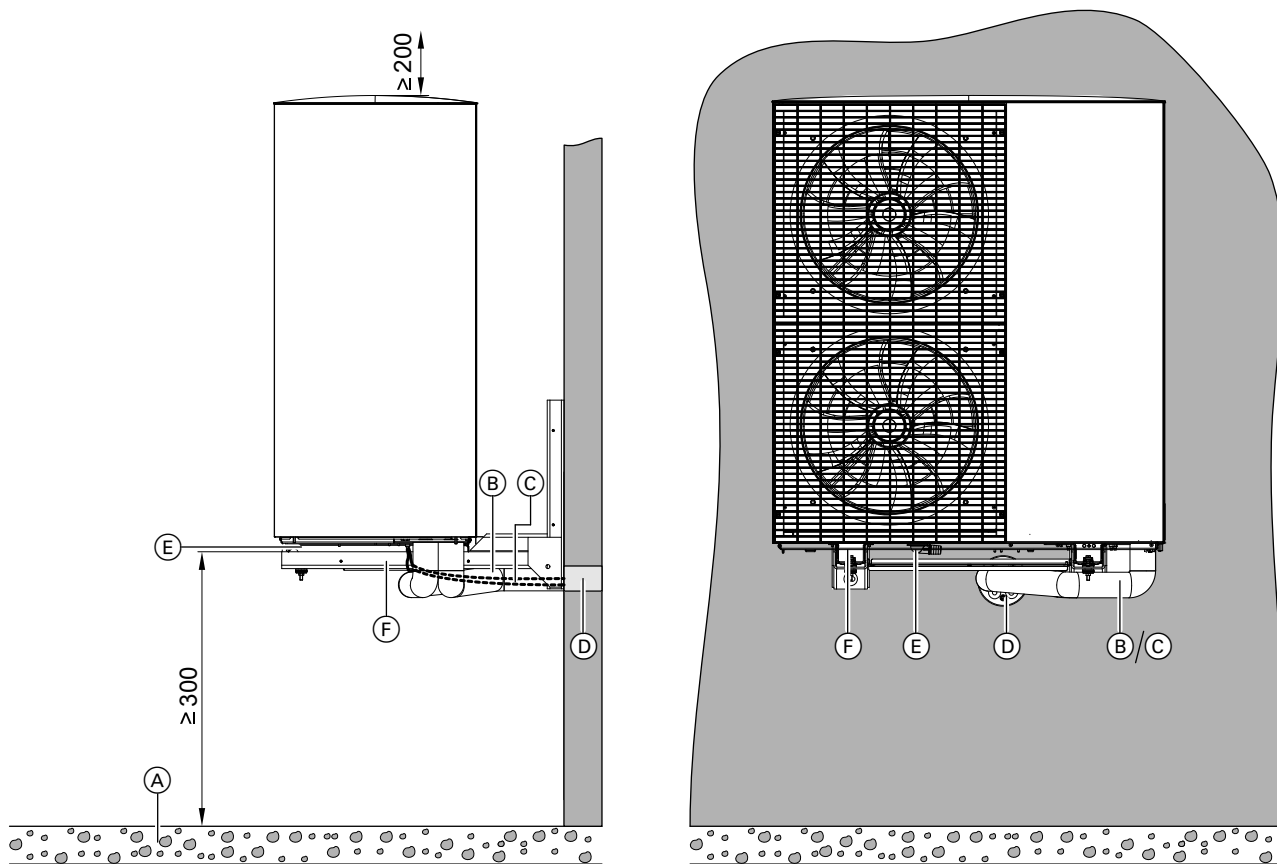

- (A) Gravel bed as condensate soakaway
- (B) Connection set for wall mounting bracket (accessories)
- (C) Indoor/outdoor unit CAN bus communication cable and outdoor unit power cable:
Route the cables free of stress.

- (D) Gas-tight wall outlet (accessories) for electrical cables and hydraulic lines
- (E) Condensate drain in the base plate:
Do not seal the opening.
- (F) Bracket for wall mounting (accessories)

Note

- For precise marking of the drill holes, a drilling template is supplied with the wall mounting bracket.
- Provide thermal insulation of sufficient thickness on the pipework to the outdoor air: See table on page 68.

7.3 Siting the indoor unit

Installation room requirements

- The installation room must be dry and free from the risk of frost.
- Ensure ambient temperatures between 0 and 35 °C.
- Max. 70 % relative humidity: Corresponding to an absolute humidity of approx. 25 g water vapour/kg of dry air at 35 °C.
- Avoid dust, gases and vapours due to a risk of explosion in the installation room.

Siting requirements

- Provide a drain connection for the safety valve.
Connect the safety valve drain hose to the waste water system with a fall and a pipe vent.
- Provide shut-off equipment for heating water flow, heating water return and DHW cylinder return.

Design information (cont.)

Minimum room height Vitocal 151-A

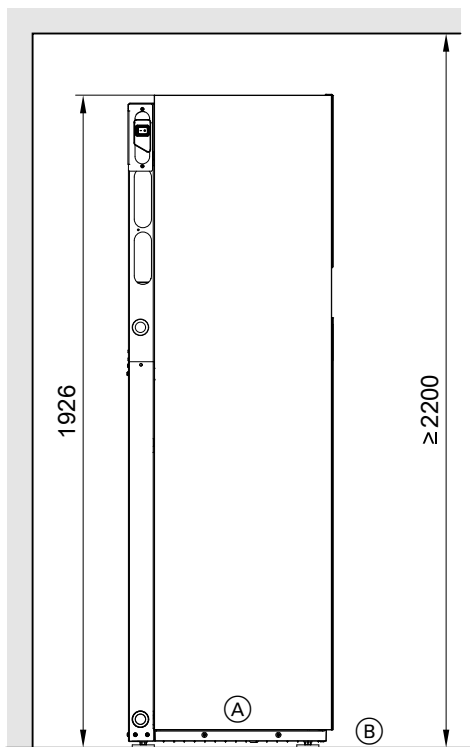

- (A) Indoor unit with integral DHW cylinder
- (B) Finished floor level or top edge of platform for unfinished floors

Minimum installation height of Vitocal 150-A

In the delivered condition, the programming unit is located at the bottom. For easier access, the programming unit can be fitted at the top, e.g. for lower installation heights.

Recommended dimensions

		a	b
Without pre-plumbing jig for surface mounting	mm	≥ 600	≥ 500
With pre-plumbing jig for surface mounting (accessories)	mm	≥ 680	≥ 680

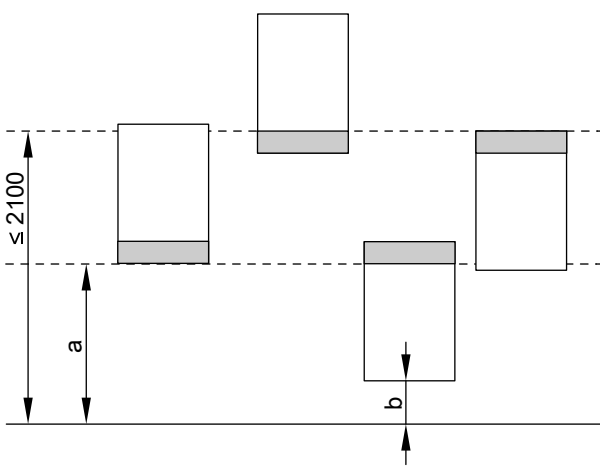

Design information (cont.)

Minimum clearances Vitocal 150-A

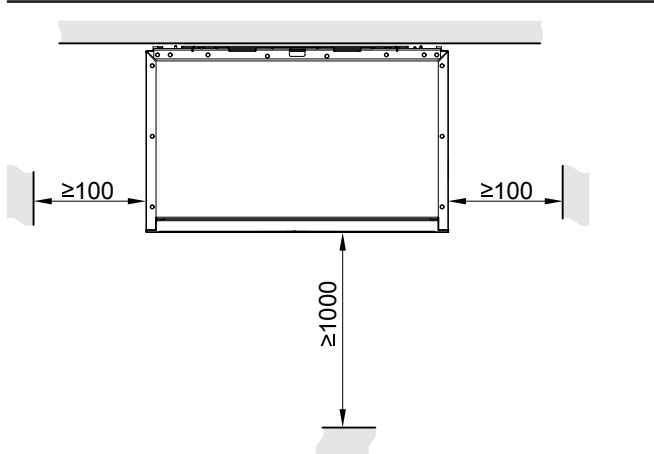

Minimum clearances Vitocal 151-A

Secondary circuit connections, left/top

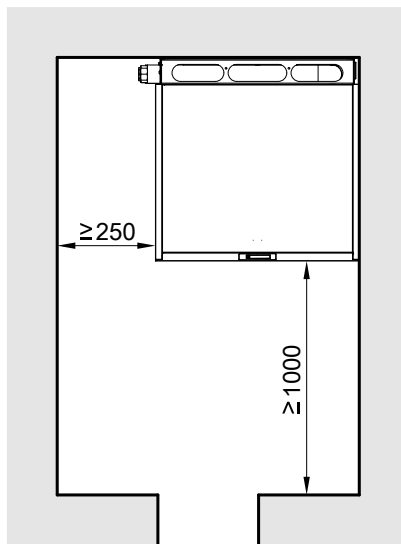

Secondary circuit connections, right/top

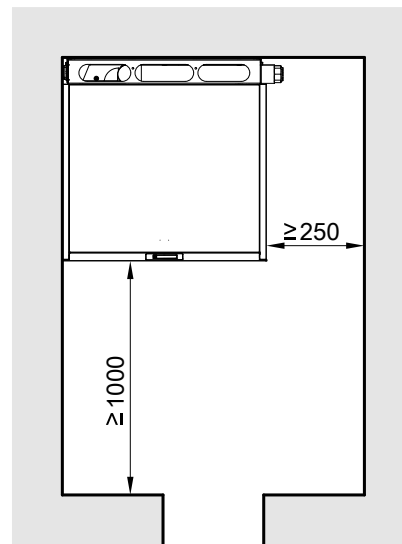

Design information (cont.)

Pressure points for Vitocal 151-A

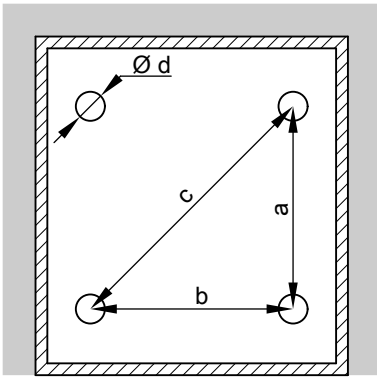

- a 478 mm
- b 478 mm
- c 677 mm
- d 64 mm

Note

- Observe the permissible floor load.
- Level the appliance horizontally.
- If the adjustable feet are used to compensate for an uneven floor (max. 10 mm), distribute the pressure load on the individual feet evenly.
- The total weight of the indoor unit with filled DHW cylinder and 1 integral heating/cooling circuit is 386 kg. Each pressure point (each with an area of 3217 mm²) is subject to a load of up to 96.5 kg.
- The total weight of the indoor unit with filled DHW cylinder and 2 integral heating/cooling circuits is 426 kg. Each pressure point (each with an area of 3217 mm²) is subject to a load of up to 109 kg.

7.4 Connection between the indoor and outdoor units

Cable entry through the wall

Suitable as wall sealing flange for brickwork

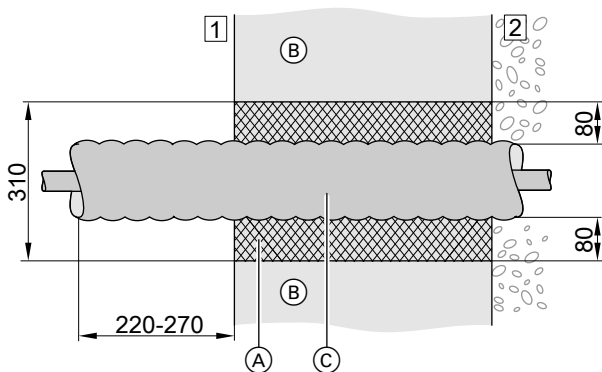

- Ⓒ Hydraulic connection set (accessories)
- 1 Inside the building
- 2 Outside the building

- Ⓐ Expanding mortar
- Ⓑ External wall

Note

Make the cable entry gas-tight.

Cable entry through the floor plate

Note

If the connections on the building side are positioned at ground level (see the diagram on the right) then we recommend that the required connection lines and inlets should be positioned **before** the foundation slab is constructed.

Any retrofitted installation will be very expensive.

Design information (cont.)

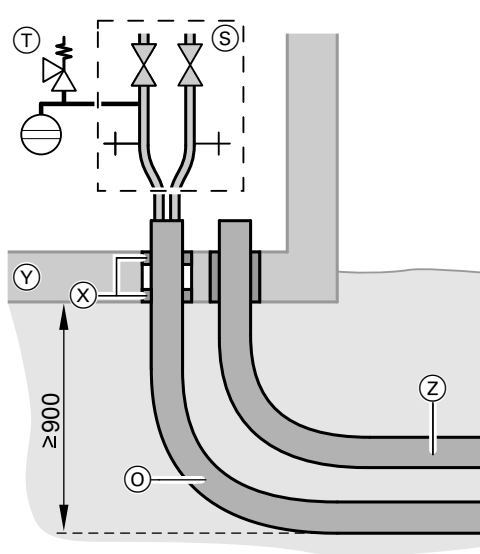

Connections on the building side at ground level

- ⓪ Hydraulic connection set (accessory)
- Ⓢ Drain & fill facility (for draining with compressed air)
- Ⓣ Expansion vessel with safety assembly (accessories)
- ⓧ Moisture-proof and waterproof wall duct (on site)
- Ⓨ Foundation slab of the building
- Ⓩ DN 100 KG conduit for external connections, control unit/heat pump (on site, with state-of-the-art building seal)

Note

Make the cable entry gas-tight.

7.5 Electrical connections

Electrical installation requirements

- Observe the technical connection requirements specified by your local power supply utility.
- Your local power supply utility will provide you with details regarding the required metering and switching equipment.
- Provide a separate electricity meter for the heat pump.

Mains voltage

The heat pumps are operated with 230 V~ or 400 V~, depending on type:

Vitocal 150-A

Type	Compressor	
	230 V~	400 V~
AWO-M-E-AC 151.A	X	
AWO-M-E-AC 151.A SP		
AWO-M-E-AC-AF 151.A		
AWO-M-E-AC-AF 151.A SP		
AWO-E-AC 151.A		X
AWO-E-AC-AF 151.A		

Vitocal 151-A

Type	Compressor	
	230 V~	400 V~
AWOT-M-E-AC 151.A	X	
AWOT-M-E-AC 151.A SP		
AWOT-M-E-AC-AF 151.A		
AWOT-M-E-AC-AF 151.A SP		
AWOT-E-AC 151.A		X
AWOT-E-AC-AF 151.A		

- The fan fuses are located in the outdoor unit.
- The instantaneous heating water heater is operated with 400 V~ or 230 V~. The instantaneous heating water heater is located in the indoor unit.
- The control circuit requires a power supply of 230 V~. The fuses for the control circuit (6.3 A) are located in the indoor unit.

Power-OFF

If economy tariffs are available, the power supply utility can switch off the compressor and instantaneous heating water heater (if present) at certain times of day via an external switching contact. This must **not** shut off the power supply to the heat pump control unit.

Wiring diagram

Vitocal 150-A

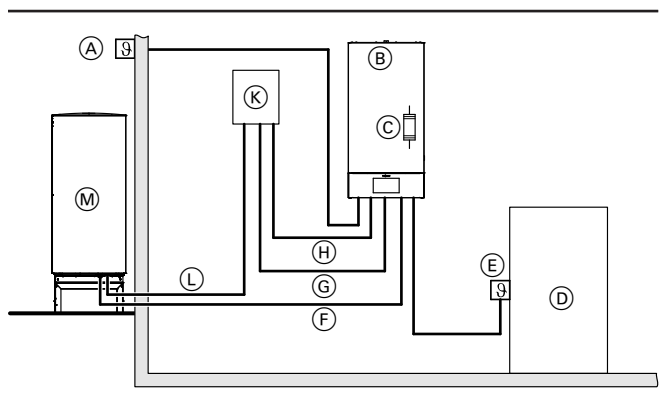

- Ⓐ Outside temperature sensor, sensor lead: 2 x 1.5 mm²
- Ⓑ Indoor unit

Design information (cont.)

- (C) Instantaneous heating water heater
- (D) DHW cylinder
- (E) Cylinder temperature sensor with sensor lead (accessory)
- (F) CAN bus cable for indoor/outdoor unit (accessory or supplied on site): See chapter "CAN bus cable for indoor/outdoor unit (on site)".
- (G) Power cable for heat pump control unit: See chapter "Recommended power cables".
- (H) Power cable for instantaneous heating water heater: See chapter "Recommended power cables".
- (K) Electricity meter/mains
- (L) Compressor power cable, 230 V~ or 400 V~: See chapter "Recommended power cables".
- (M) Outdoor unit

Vitocal 151-A

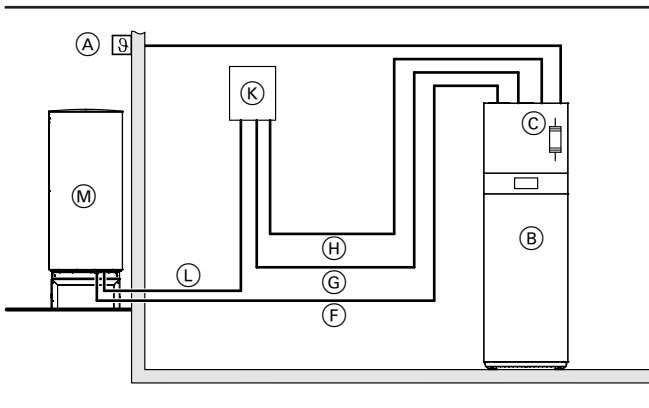

- (A) Outside temperature sensor, sensor lead: 2 x 1.5 mm²
- (B) Indoor unit
- (C) Instantaneous heating water heater
- (F) CAN bus cable for indoor/outdoor unit (accessory or supplied on site): See chapter "CAN bus cable for indoor/outdoor unit (on site)".
- (G) Power cable for heat pump control unit: See chapter "Recommended power cables".
- (H) Power cable for instantaneous heating water heater: See chapter "Recommended power cables".
- (K) Electricity meter/mains
- (L) Compressor power cable, 230 V~ or 400 V~: See chapter "Recommended power cables".
- (M) Outdoor unit

Note

For the external buffer cylinder and the heating/cooling circuits connected to it, additional power supply cables, control cables and sensor cables must be factored in. Check the power cable cross-sections. Enlarge if necessary.

Recommended power cables

Indoor unit

Power supply	Cable	Max. cable length
Control unit/PCB 230 V~	– Without power-OFF	3 x 1.5 mm ² 50 m
	– With power-OFF	5 x 1.5 mm ² 50 m
Instantaneous heating water heater	– 400 V~	5 x 2.5 mm ² 25 m
	– 230 V~	7 x 2.5 mm ² 25 m

For central power supply on types ... SP

Power supply	Cable	Max. cable length
Indoor unit 230 V~	3 x 6.0 mm ²	30 m

Cable lengths in the indoor unit

Vitocal 150-A

Connection cables	Cable lengths in the indoor unit
– 230 V~, e.g. for circulation pumps	0.5 m
Note Route the cables to the HPMU electronics module so they are flexible.	
– < 42 V, e.g. for sensors	0.7 m

Note

- Some connection areas, e.g. for power supply and the CAN bus communication cable, are located on the underside of the indoor unit.
- The electrical cables/leads required for operation of the outdoor unit are connected only to the **outside** of the outdoor unit.

Vitocal 151-A

Connection cables	Cable lengths in the indoor unit
– 230 V~, e.g. for circulation pumps	1.3 m
Note Route the cables to the HPMU electronics module so they are flexible.	
– < 42 V, e.g. for sensors	0.8 m

Note

The electrical cables/leads required for operation of the outdoor unit are connected only to the **outside** of the outdoor unit.

CAN bus communication cable to indoor/outdoor unit

Recommended connection cable (accessory)

Fully wired, shielded CAN bus communication cable between the outdoor and indoor unit; length 5 m, 10 m or 30 m (accessories)

On-site cables

Twisted pair cable, shielded, to ISO 11898-2 (recommended)

Cable cross-section	0.34 to 0.6 mm ²
Characteristic impedance	95 to 140 Ω
Max. length	200 m

CAT5 cable, shielded, 2-core (alternative)

Max. length	50 m
-------------	------

Design information (cont.)

Outdoor units

Power supply	Cable	Max. cable length
Outdoor unit 230 V~	3 x 2.5 mm ²	20 m
	3 x 4.0 mm ²	32 m
Outdoor unit 400 V~	5 x 2.5 mm ²	30 m

7.6 Noise emissions

Principles

Sound power level L_W

This describes the entire sound emissions in all directions emanating from the heat pump. It does **not** depend on the surrounding conditions (reflections) and is a value that can be used for direct comparisons of sound sources (heat pumps).

Sound pressure level L_p

The sound pressure level is a measure to assist orientation regarding the volume of noise perceived by the ear at a specific location. The sound pressure level is substantially influenced by the distance and ambient conditions. The sound pressure level is thus dependent on the measuring location, which is often at a distance of 1 m. Standard measuring microphones measure the sound pressure directly.

The sound pressure level is the variable that is used to assess immissions from individual systems.

Sound reflection and sound pressure level (directivity Q)

The sound pressure level increases exponentially with the number of adjacent, vertical, fully reflective surfaces (e.g. walls) compared to installation in a free field ($Q =$ directivity), as sound projection is restricted compared to installation in a free field.

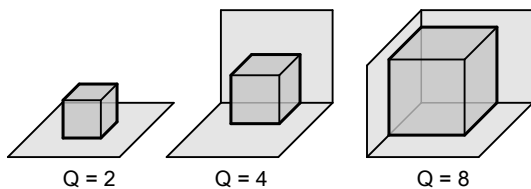

Q Directivity

Q=2: Freestanding outdoor unit at a large distance from the building

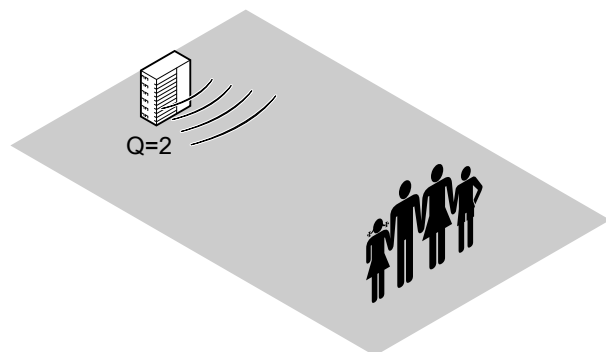

Q=4: Outdoor unit close to a house wall

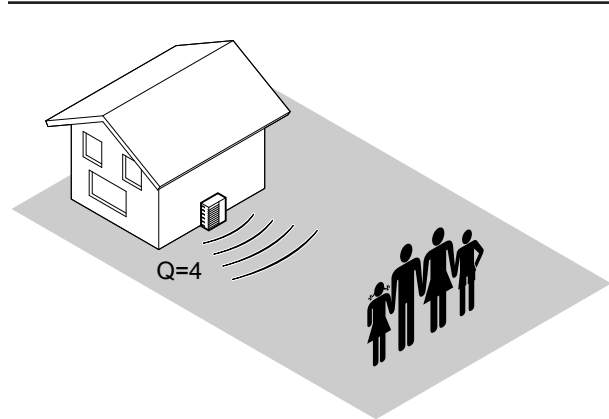

Q=8: Outdoor unit close to a house wall, next to a projecting wall corner

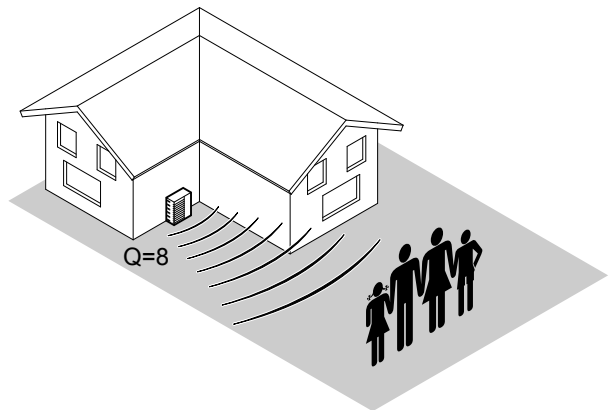

The following table shows the extent to which the sound pressure level L_p changes according to directivity Q and the distance from the appliance in relation to the sound power level L_W measured directly at the appliance or at the air discharge. The values listed in the table were calculated according to the following formula:

$$L = L_W + 10 \cdot \log \left(\frac{Q}{4 \cdot \pi \cdot r^2} \right)$$

L	=	Sound level at the receiver
L_W	=	Sound power level at the sound source
Q	=	Directivity
r	=	Distance between receiver and sound source

Design information (cont.)

The legal requirements concerning sound propagation apply under the following idealised conditions:

- The sound source is a point source of sound.
- Installation and operating conditions for the heat pump correspond to the conditions when determining the sound power.
- At Q=2, sound is emitted in a free field, no surrounding reflective objects/buildings.
- At Q=4 and Q=8, full reflection on adjacent surfaces is assumed.
- Unrelated noise from other surrounding sources is not taken into account.

Directivity Q, calculated on site	Distance from the sound source in m								
	1	2	4	5	6	8	10	12	15
	Energy-equivalent duration of sound pressure level L_p of the heat pump in relation to the sound power level L_w measured at the appliance/air duct in dB(A)								
2	-8.0	-14.0	-20.0	-22.0	-23.5	-26.0	-28.0	-29.5	-31.5
4	-5.0	-11.0	-17.0	-19.0	-20.5	-23.0	-25.0	-26.5	-28.5
8	-2.0	-8.0	-14.0	-16.0	-17.5	-20.0	-22.0	-23.5	-25.5

Note

- In practice, actual values may differ from those shown here due to sound reflection or sound absorption as a result of local conditions. Therefore, the situations described by Q=4 and Q=8, for example, often give only an approximate picture of the actual conditions at the emission site.
- If the heat pump sound pressure level as calculated approximately from the table is less than 3 dB(A) different from the permissible standard value given by the TA Lärm, a precise sound immissions prognosis must be produced (consult an acoustic engineer).

Standard values for assessing the sound pressure level to TA Lärm (measured outside the building)

Area/object ^{*8}	Standard immissions value (sound pressure level) in dB(A) ^{*9}	
	During the day	At night
Area with a mix of commercial installations and residential units where neither commercial installations nor residential units dominate.	60	45
Areas with predominantly residential units.	55	40
Areas with only residential units.	50	35
Residential units that are structurally connected to the heat pump system	40	30

Note

- Sound emission (TA-Lärm) regulations must be observed [in Germany].
- When siting the heat pump, always take into account the distances to neighbouring property in accordance with local building regulations.

Sound pressure level at different distances to the appliance

Outdoor unit type 151.A10, 230 V~

Fan speed	Sound power level L_w in dB(A) ^{*10}	Directivity Q	Distance from the outdoor unit in m								
			1	2	4	5	6	8	10	12	15
			Sound pressure level L_p in dB(A) ^{*11}								
Night	59	2	51	45	39	37	35	33	31	29	27
		4	54	48	42	40	38	36	34	32	31
		8	57	51	45	43	41	39	37	35	34
Max.	66	2	58	52	46	44	42	40	38	36	34
		4	61	55	49	47	45	43	41	39	38
		8	64	58	52	50	48	46	44	42	41

^{*8} Determined according to outline planning restrictions; check with local authorities.

^{*9} Valid for the sum of all sounds that have an influence.

^{*10} Total sound power level measurement performed with reference to EN ISO 12102/EN ISO 9614-2, accuracy category 2 under the following conditions: $A 7^{\pm 3} K/W 55^{\pm 2} K$

^{*11} Determined by calculation on the basis of the actual effective total sound power level, in accordance with the formula in chapter "Principles"

Design information (cont.)

Outdoor unit type 151.A13, 230 V~

Fan speed	Sound power level L_W in dB(A) ^{*10}	Directivity Q	Distance from the outdoor unit in m								
			1	2	4	5	6	8	10	12	15
			Sound pressure level L_p in dB(A) ^{*11}								
Night	59	2	51	45	39	37	35	33	31	29	27
		4	54	48	42	40	38	36	34	32	31
		8	57	51	45	43	41	39	37	35	34
Max.	66	2	58	52	46	44	42	40	38	36	34
		4	61	55	49	47	45	43	41	39	38
		8	64	58	52	50	48	46	44	42	41

Outdoor unit type 151.A16, 230 V~

Fan speed	Sound power level L_W in dB(A) ^{*10}	Directivity Q	Distance from the outdoor unit in m								
			1	2	4	5	6	8	10	12	15
			Sound pressure level L_p in dB(A) ^{*11}								
Night	59	2	51	45	39	37	35	33	31	29	27
		4	54	48	42	40	38	36	34	32	31
		8	57	51	45	43	41	39	37	35	34
Max.	66	2	58	52	46	44	42	40	38	36	34
		4	61	55	49	47	45	43	41	39	38
		8	64	58	52	50	48	46	44	42	41

Outdoor unit type 151.A10, 400 V~

Fan speed	Sound power level L_W in dB(A) ^{*10}	Directivity Q	Distance from the outdoor unit in m								
			1	2	4	5	6	8	10	12	15
			Sound pressure level L_p in dB(A) ^{*11}								
Night	59	2	51	45	39	37	35	33	31	29	27
		4	54	48	42	40	38	36	34	32	31
		8	57	51	45	43	41	39	37	35	34
Max.	66	2	58	52	46	44	42	40	38	36	34
		4	61	55	49	47	45	43	41	39	38
		8	64	58	52	50	48	46	44	42	41

Outdoor unit type 151.A13, 400 V~

Fan speed	Sound power level L_W in dB(A) ^{*10}	Directivity Q	Distance from the outdoor unit in m								
			1	2	4	5	6	8	10	12	15
			Sound pressure level L_p in dB(A) ^{*11}								
Night	59	2	51	45	39	37	35	33	31	29	27
		4	54	48	42	40	38	36	34	32	31
		8	57	51	45	43	41	39	37	35	34
Max.	66	2	58	52	46	44	42	40	38	36	34
		4	61	55	49	47	45	43	41	39	38
		8	64	58	52	50	48	46	44	42	41

Outdoor unit type 151.A16, 400 V~

Fan speed	Sound power level L_W in dB(A) ^{*10}	Directivity Q	Distance from the outdoor unit in m								
			1	2	4	5	6	8	10	12	15
			Sound pressure level L_p in dB(A) ^{*11}								
Night	59	2	51	45	39	37	35	33	31	29	27
		4	54	48	42	40	38	36	34	32	31
		8	57	51	45	43	41	39	37	35	34
Max.	66	2	58	52	46	44	42	40	38	36	34
		4	61	55	49	47	45	43	41	39	38
		8	64	58	52	50	48	46	44	42	41

*10 Total sound power level measurement performed with reference to EN ISO 12102/EN ISO 9614-2, accuracy category 2 under the following conditions: A 7[±]3K/W 55[±]2K

*11 Determined by calculation on the basis of the actual effective total sound power level, in accordance with the formula in chapter "Principles"

Design information (cont.)

Note

In practice, actual values may differ from those shown here due to sound reflection or absorption as a result of local conditions. Therefore, the situations described for example by $Q=4$ and $Q=8$ often give only an approximate picture of the actual conditions at the emission site.

Information on reducing sound emissions

- Do not site the outdoor unit immediately next to/above living/bedrooms or their windows.
- Structure-borne noise insulation of the outdoor unit to the building structure must be ensured by on-site measures.
- Line entries through ceilings, walls and roofs must have sound insulation. Use suitable insulating materials to prevent the transmission of airborne and structure-borne noise: See the information about siting the indoor unit on page 76 onwards.
- Do not site the outdoor unit immediately next to neighbouring buildings or properties. See the information about siting the outdoor unit on page 66 onwards.
- The sound pressure level can increase if the outdoor unit is sited in unfavourable physical positions.
In this context, please observe the following:
 - Avoid surroundings with reverberant floors (e.g. concrete or paving), as the sound pressure level can be increased through reflection. Surroundings where the ground is covered with vegetation (e.g. a lawn) can noticeably reduce the sound pressure level.
 - Site the outdoor unit with as much space around it as possible: See page 82.
- If the requirements of the TA Lärm [Germany] are not observed, suitable building measures (e.g. additional planting) must be employed to reduce the sound pressure level to acceptable levels: See page 82.

7.7 Sizing the heat pump

First establish the standard heat load Φ_{HL} of the building. For discussions with customers and for the preparation of a quotation, in most cases estimating the heat load is adequate.

As with all heating systems, determine the standard heat load of the building to EN 12831 before ordering the appropriate heat pump.

Mono mode operation

According to EN 12831, the heat pump in a mono mode system, as the sole heat generator, must be able to cover the entire heat demand of the building.

For mono mode operation, take into account the likely primary inlet temperatures at the installation site and the heat pump application limits:

For minimum primary inlet temperature and minimum secondary circuit flow temperature: See chapter "Application limits to EN 14511". Please also note that, in mono mode, the heat pump heating output and the maximum secondary circuit flow temperature are influenced by the primary inlet temperature. This can result in comfort losses, for DHW heating in particular.

Therefore please note the following design points:

- Check whether the maximum heat pump flow temperature, achieved at the prevailing primary inlet temperatures, fulfils the local DHW heating requirements.
- During commissioning or service, the secondary circuit temperature may lie below the required minimum heat pump flow temperature. The heat pump compressor does not then start independently.
- If frost protection mode is permanently enabled (e.g. in a holiday home), the secondary circuit temperature can drop below the minimum heat pump flow temperature. The heat pump compressor does not then start independently.

As a result, even with a mono mode heat pump design, an additional heat generator must always be included in the design; e.g. an instantaneous heating water heater.

If the heat pump **cannot** meet the heat demand in mono mode, it must be operated in **mono energetic mode** (with instantaneous heating water heater) or in **dual mode** (with external heat generator). Otherwise there is a risk of the condenser freezing, causing significant damage to the heat pump.

Sizing is of particular relevance to heat pump systems that are to be operated in mono mode, since oversized equipment frequently incurs disproportionate system costs. Oversizing should therefore be avoided!

When sizing the heat pump, observe the following:

- Take into account supplements to the heat load of the building to cover power-OFF periods. [In Germany] the power supply utility may interrupt the power supply of heat pumps for up to 3 x 2 hours within a period of 24 hours.
Observe additional individual arrangements for customers with special tariffs.
- The building inertia means that 2 hours of power-OFF time are generally not taken into consideration.

Design information (cont.)

Note

The ON periods between 2 power-OFF times must be at least as long as the preceding power-OFF time.

Estimate of the heat load based on the heated area

The heated surface area (in m²) is multiplied by the following specific heat demand:

Passive house	10 W/m ²
Low energy house	40 W/m ²
New build (to EnEV)	50 W/m ²
House (built prior to 1995 with standard thermal insulation)	80 W/m ²
Older house (without thermal insulation)	120 W/m ²

Theoretical sizing with power-OFF time of 3 × 2 hours or when used in Smart Grid

Example:

Low energy house (40 W/m²) and a heated area of 180 m²

■ Estimated heat load: 7.2 kW

■ Maximum blocking time of 3 × 2 hours at a minimum outside temperature in accordance with EN 12831

24 h, therefore, result in a daily heat volume of:

■ 7.2 kW · 24 h = 173 kWh

To cover the maximum daily heat volume, only 18h/day are available on account of the times when the power supply is blocked. The building inertia means that 2 hours of the period during which power is blocked are not taken into consideration.

■ 173 kWh / (18 + 2) h = 8.65 kW

In other words, the heat pump heating output would need to be increased by 20 % if the power supply were blocked for a maximum of 3 × 2 hours per day.

Frequently, blocking times are only invoked if there is a need to do so. Please contact the customer's power supply utility to enquire about blocking times.

Supplement for DHW heating in mono mode operation

Note

In dual mode heat pump operation, the heating output available is generally so high that this supplement does not need to be taken into consideration.

For a general residential building, a max. DHW demand of approx. 50 l per person per day at approx. 45 °C is assumed.

■ This demand represents an additional heat load of approx. 0.25 kW per person given a heat-up time of 8 h.

■ This supplement will only be taken into consideration if the sum total of the additional heat load exceeds 20 % of the heat load calculated to EN 12831.

	DHW demand at a DHW temperature of 45 °C in l per person/day	Specific available heat in Wh per person/day	Recommended heat load supplement for DHW heating* ¹² in kW/person
Low demand	15 to 30	600 to 1200	0.08 to 0.15
Standard demand* ¹³	30 to 60	1200 to 2400	0.15 to 0.30

Or

	DHW demand at a DHW temperature of 45 °C in l per person/day	Specific available heat in Wh per person/day	Recommended heat load supplement for DHW heating* ¹² in kW/person
Apartment (billing according to demand)	30	Approx. 1200	Approx. 0.150
Apartment (flat rate billing)	45	Approx. 1800	Approx. 0.225
Detached house* ¹³ (average demand)	50	Approx. 2000	Approx. 0.250

Supplement for setback mode

As the heat pump control unit is equipped with a temperature limiter for setback mode, the supplement for setback mode to EN 12831 can be ignored.

In addition, the control unit is equipped with start optimisation, which means that there is also no need for a supplement for heating up from setback mode.

Both functions must be enabled in the control unit. If any of the supplements are omitted because of the activated control unit functions then this must be documented when the system is handed over to the operator.

If, irrespective of the above mentioned control options, these supplements are nevertheless to be taken into account, the calculation should be made with reference to EN 12831.

Mono energetic operation

In heating mode, the heat pumps are supported by the integral instantaneous heating water heater. The control unit switches the instantaneous heating water heater on, subject to the outside temperature (dual mode temperature) and heat load.

Sizing for a typical system configuration:

- Size the heating output of the heat pump to approx. 70 to 85 % of the maximum required building heat load to EN 12831.
- The heat pump covers approx. 95 % of the annual heat load.
- Blocking times do not need to be taken into consideration.

Note

That part of the electric power drawn by the instantaneous heating water heater will generally **not** be charged at special tariffs.

*¹² With a DHW cylinder heat-up time of 8 h.

*¹³ Select a higher supplement if the actual DHW demand exceeds the stated values.

Design information (cont.)

Note

The reduced size of the heat pump, compared to mono mode operation, means that the runtime will increase.

7.8 Hydraulic conditions for the secondary circuit

Minimum flow rate and minimum system volume

To ensure fault-free operation of an air source heat pump, a minimum flow rate and minimum system volume must be observed.

For the air source heat pumps described in these instructions, both requirements are ensured by the factory-fitted Hydro AutoControl. Hydro AutoControl includes, among others, a factory-fitted buffer cylinder in the indoor unit and an electronically controlled overflow valve. This means the required defrost energy and the minimum flow rate of the system are always available.

Systems with an external buffer cylinder connected in parallel

In addition to the buffer cylinder built into the indoor unit, the heat pump can also supply an external buffer cylinder connected in parallel.

Benefits

- Heating circuits with mixer can be supplied with a different flow temperature to a heating circuit without mixer.
- The system can be supplied by additional heat sources:
 - External buffer cylinder heating via solar central heating backup
 - External buffer cylinder heating via the heat pump, if electrical energy is provided by self-generated power from the photovoltaic system.
- Bridging power-OFF times:
Subject to the electricity tariff, heat pumps can be switched off at peak times by the power supply utility. The external buffer cylinder supplies the heating circuits even during this power-OFF time.
- An additional external buffer cylinder can significantly extend the runtime of the heat pump. This prevents frequent starting and stopping (cycling) of the heat pump.

Implementation instructions

- When sizing the external buffer cylinder, note whether underfloor and/or radiator heating circuits are connected.
- Due to the large volume of water and possible separate shut-off equipment for the heat generator, allow for a second or a larger expansion vessel.
- Set up the safety equipment for the system according to EN 12828.
- The volumetric flow rate of the secondary pump must be greater than that of the heating circuit pumps.
- In conjunction with an underfloor heating circuit, a temperature limiter must be installed to limit the maximum temperature of underfloor heating (part no. 7151728 or 7151729).

Systems without external buffer cylinder

Through Hydro AutoControl, the minimum system volume and minimum flow rate are always available. The heat pump can therefore safely defrost at any time

To prevent the building from cooling down, fit an external buffer cylinder with a minimum volume of 200 l under the following conditions:

- The system is operated solely with radiators.
And
- The selected electricity tariff includes a power-OFF period.

Max. hydraulic system pressure

The maximum system pressure on the heating water side is 3 bar (0.3 MPa). Do not exceed this hydraulic pressure!





7.9 Design guide for the secondary circuit

Through Hydro AutoControl, the minimum system volume and minimum flow rate are always available.



The following table gives an overview of the components used to supply the connected heating/cooling circuits reliably and safely.

- Pipework cross-sections in secondary circuit
- Integral buffer cylinder (factory-installed)
- External buffer cylinder connected in parallel to the heat pump

Design information (cont.)

Sizing	\dot{V}_{min} in l/h	\varnothing_{pipes}	Buffer cylinder (recommended minimum)		
			 or 	 + PSU	 +  + PSU
New build	1000	DN 32	Integrated buffer cylinder	Vitocell 100-E, 200 l	
Modernisation	1000	DN 20	Integrated buffer cylinder	Vitocell 100-E, 200 l	

Icons:

- \dot{V}_{min} Minimum flow rate, secondary circuit
- \varnothing_{pipes} Minimum diameter of pipes in secondary circuit
-  Underfloor heating circuit
-  Radiator heating circuit
- PSU Electricity tariff with power-OFF period

Note

The minimum flow rate \dot{V}_{min} shown in the table relates to the hydraulic circuit between the indoor and outdoor units. This minimum flow rate is ensured by Hydro AutoControl under the following conditions:

- The pipework uses DN 32 pipes.
And
- The maximum length of the pipework between the indoor and outdoor units is 20 m.

Pipework volume

Pipe	Nominal diameter	Dimension x wall thickness in mm	Volume in l/m
Copper pipe	DN 20	22 x 1	0.31
	DN 25	28 x 1	0.53
	DN 32	35 x 1	0.84
	DN 40	42 x 1	1.23
	DN 50	54 x 2	2.04
	DN 60	64 x 2	2.83
Threaded pipes	¾	26.9 x 2.65	0.37
	1	33.7 x 3.25	0.58
	1¼	42.4 x 3.25	1.01
	1½	48.3 x 3.25	1.37
	2	60.3 x 3.65	2.21
Composite pipes	DN 20	26 x 3.0	0.31
	DN 25	32 x 3.0	0.53
	DN 32	40 x 3.5	0.86
	DN 40	50 x 4.0	1.39
	DN 50	63 x 6.0	2.04
Hydraulic connection lines	DN 32	40 x 3.7	0.84
	DN 40	50 x 4.6	1.31

Note

If the heat pump is also used for cooling, the heating water flow and heating water return must be thermally insulated with vapour diffusion-proof material.

Further hydraulic data

Circulation pump	Factory-fitted
Residual heads with integral circulation pump	See pages 15 and 26.

7.10 Water quality

Heating water

Unsuitable fill and top-up water increases the level of deposits and corrosion. This can lead to system damage.

Hard water can also cause damage to the instantaneous heating water heater in particular.

Observe VDI 2035 regarding quality and amount of heating water, including fill and top-up water.

- Flush the heating system thoroughly before filling.
- Only fill with water of potable quality.
- Only use fill and top-up water with a hardness of < 3 °dH.
- Do not use antifreeze (e.g. water/glycol mixture) in the heating water.
- Do not use chemical additives in the system.

For further information about fill and top-up water: See technical guide "Heat pump principles".

Dirt and magnetite separator

Particularly with existing systems, contaminated heating water can lead to increased wear or faults with individual components, e.g. pumps and valves.

Particles of rust and dirt can reduce the efficiency of the heat pump and block the condenser. Consequently, the system cannot be guaranteed to operate without faults at all times.

The ingress of oxygen (for example via compression fittings) can also cause corrosion in new systems, e.g. on the heat exchanger in the DHW cylinder.

Design information (cont.)

We therefore recommend installing a dirt separator with magnet in both existing and new heating systems: See Vitoset pricelist.

7.11 Connection on the DHW side

For connecting the DHW side, observe EN 806, DIN 1988 and DIN 4753 (CH: SVGW regulations). Observe other country-specific standards as applicable.

Vitocal 150-A

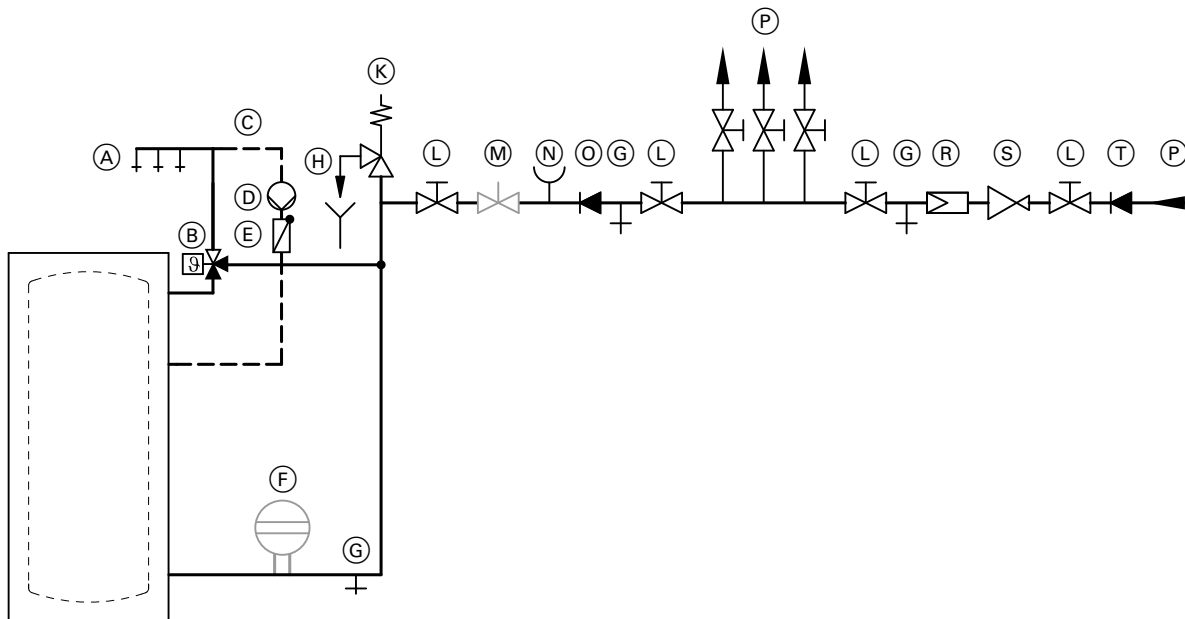

Example with Vitocell 100-V/100-W, type CVWA/CVWB

- | | |
|---|---|
| Ⓐ DHW | Ⓛ Shut-off valve |
| Ⓑ Automatic thermostatic mixing valve | Ⓜ Flow regulating valve
(installation recommended) |
| Ⓒ DHW circulation pipe | Ⓝ Pressure gauge connection |
| Ⓓ DHW circulation pump | Ⓞ Non-return valve |
| Ⓔ Spring-loaded check valve | Ⓟ Cold water |
| Ⓕ Expansion vessel, suitable for drinking water | Ⓡ Drinking water filter |
| Ⓖ Drain | Ⓢ Pressure reducer to DIN 1988-200:2012-05 |
| Ⓗ Visible discharge pipe outlet point | Ⓣ Non-return valve/pipe separator |
| Ⓚ Safety valve | |

Vitocal 151-A

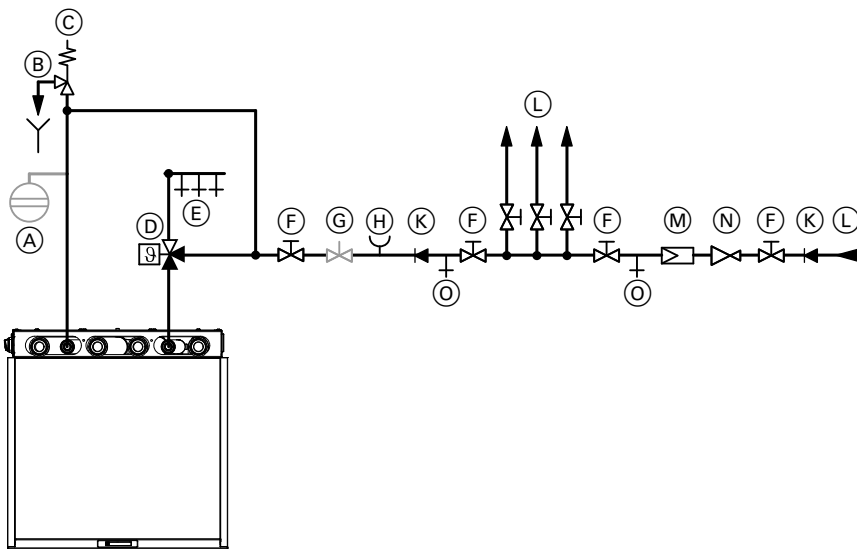

- | | |
|---|--|
| (A) Expansion vessel, suitable for drinking water | (K) Non-return valve/pipe separator |
| (B) Visible discharge pipe outlet point | (L) Cold water |
| (C) Safety valve | (M) Drinking water filter |
| (D) Automatic thermostatic mixing valve | (N) Pressure reducer to DIN 1988-200:2012-05 |
| (E) DHW | (O) Drain valve |
| (F) Shut-off valve | (P) Cold water |
| (G) Flow regulating valve | (R) Drinking water filter |
| (H) Pressure gauge connection | (S) Pressure reducer to DIN 1988-200:2012-05 |

Safety valve

The DHW cylinder **must** have a safety valve to protect against unduly high pressure.
 Recommendation: Install safety valve above top edge of cylinder. This means the DHW cylinder will not need to be drained when working on the safety valve.

CH: According to W3 "Principles for creating potable water installations", safety valves must be drained directly via a visible unrestricted drain or via a short outlet line to the drain network.

Automatic thermostatic mixing valve

With appliances that heat DHW to temperatures above 60 °C, an automatic thermostatic mixing valve must be installed in the DHW line as protection against scalding.

This also particularly applies when connecting solar thermal systems.

7.12 DHW cylinder selection

For systems with Viessmann heat pumps, we recommend using only the approved Viessmann DHW cylinders listed in this technical guide.

For the best possible system operation and efficiency, the following design information and calculation principles must be taken into account when sizing the DHW cylinder.

Note

- If a Viessmann DHW cylinder is **not** being used, it is the personal responsibility of the specialist design engineer to guarantee that the following design information and calculation principles are applied when sizing the DHW cylinder.
- Any local requirements regarding DHW heating should be taken into account in the design process.

Heat exchanger surface area

To enable the heat pump to transfer heat to the water, the DHW cylinder must have a sufficiently large heat exchanger surface area. If the surface area is too small, the return temperature will exceed the permitted value during cylinder heating and the heat pump will switch off. Cylinder heating will consequently stop before the set cylinder temperature programmed at the heat pump control unit is reached. As a result, the heat pump will switch on and off frequently while heating the cylinder and the set cylinder temperature will not be reached.

In the case of Viessmann DHW cylinders, the heat exchanger surface area required for heat pump operation has already been taken into account at the development stage. As a result, approved combinations of heat pump and DHW cylinder have been devised.

For third party cylinders, an approximate calculation of the required heat exchanger surface area may be obtained as follows:

$$A_{\min} = P \times 0.3 \text{ m}^2/\text{kW}$$

Design information (cont.)

A_{\min} Min. heat exchanger surface area in m^2

P Rated heating output of the heat pump in kW for operating point with the highest primary inlet temperature

This calculation prevents the heat pump from switching off prematurely even when the primary inlet temperature is high, e.g. in summer.

Note

- In the case of heat pumps with inverter and output-dependent control, the rated heating output can be used for the calculation, since the cylinder is heated under partial load.
- The heat exchanger surface area of third party cylinders can be found in the relevant documents provided by the manufacturer.

Max. cylinder temperature

The max. achievable cylinder temperature is influenced by the following factors:

- Secondary circuit flow temperature
- Temperature spread between secondary circuit flow and return

Flow temperature in the secondary circuit

The max. achievable flow temperature in the secondary circuit is dependent on the primary inlet temperature: See chapter "Application limits".

If the heat pump cannot achieve the required cylinder temperature in mono mode operation, it must be operated in mono energetic mode (with instantaneous heating water heater) or dual mode (with external heat generator).

Temperature spread between secondary circuit flow and return

For fault-free heat pump operation, there needs to be a sufficient temperature spread between the secondary circuit flow and return.

Vitocal 150-A

Heat pump operating mode	3 to 5 occupants DHW cylinder		6 to 8 occupants DHW cylinder	
		Capacity		Capacity
Mono mode	Vitocell 100-W, type CVAB	300 l	Vitocell 100-V, type CVA	500 l
	Vitocell 100-V/100-W, type CVWA/CVWB	300 l 390 l	Vitocell 100-V, type CVWA	500 l
			Vitocell 100-L, type CVL + cylinder loading system	500 l
Dual mode	Vitocell 100-W, type CVBC	300 l	Vitocell 100-B, type CVBB	500 l

To ensure the DVGW Code of Practice is fulfilled, an instantaneous heating water heater or second heat generator should be installed, so that DHW temperatures reach $> 60\text{ }^{\circ}\text{C}$. Equipping the heat pump with an instantaneous heating water heater fulfils this requirement.

Particularly with heat pumps with a fixed heating output, a high temperature spread enables the cylinder to be efficiently heated up to the set cylinder temperature.

Standard values for the temperature spread for adjustment of the flow rate at the start of cylinder heating:

- Heat pumps with fixed heating output: 5 to 8 K
- Heat pumps with inverter and output-dependent control: 4 to 5 K

Lines to the DHW cylinder

For highly efficient DHW heating, we recommend taking the following into account:

- Observe the minimum diameter for the lines connecting the DHW cylinder to the heat pump: See chapter "Design guide for the secondary circuit"
- Keep the lines between heat pump and DHW cylinder as short as possible and keep changes of direction to a minimum.

Maximum cylinder storage temperature with Vitocal 150-A

The maximum cylinder storage temperature depends on the selected DHW cylinder and on the heat exchanger that is installed in it. Depending on the DHW cylinder, the maximum cylinder storage temperature will be between $50\text{ }^{\circ}\text{C}$ and $60\text{ }^{\circ}\text{C}$.

Note

- The stated cylinder storage temperature can only be achieved in the temperature range within the application limits to EN 14511 in which the heat pump reaches the max. flow temperature.
- The cylinder sizes listed in the following table are **standard values**. They are based on the following DHW demand: 50 l per person per day at a DHW temperature of $45\text{ }^{\circ}\text{C}$

Specification – DHW cylinder

See technical guides for DHW cylinders.

System examples

DHW cylinder with internal indirect coils

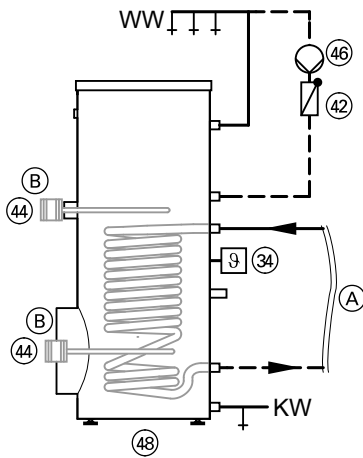

Hydraulic diagram when using Vitocell 100-V/100-W, type CVWA/CVWB

- (A) Heat pump connection
- (B) Immersion heater EHE can be installed in top or bottom section
- KW Cold water
- WW DHW

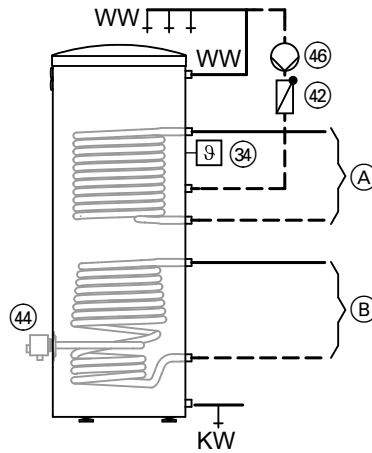

Hydraulic diagram when using Vitocell 100-B, type CVBC or Vitocell 100-W, type CVBC, 300 I (as dual mode system) or Vitocell 100-W, type CVAB, 300 I

- (A) External heat generator connection
- (B) Heat pump connection
- KW Cold water
- WW DHW

Equipment required

Pos.	Description	Quantity	Part no.
(34)	Cylinder temperature sensor	1	7438702
(42)	Spring-loaded check valve	1	On site
(44)	Immersion heater EHE	1	See Viessmann pricelist.
(46)	DHW circulation pump	1	See Vitoset pricelist.
(48)	DHW cylinder	1	See Viessmann pricelist.

7.13 Cooling mode

For cooling, the heat pumps operate in reverse mode. This means that the heat pump cycle is reversed.

System configurations for room cooling

Depending on the system configuration, cooling mode is possible via one or via several heating/cooling circuits simultaneously.

- Cooling mode is possible via the heating/cooling circuits directly connected to the indoor unit.
- Cooling is **not** possible via a heating circuit connected to an external buffer cylinder.

For detailed information on system examples with room cooling: www.viessmann-schemes.com

Cooling circuits

Cooling is provided via a heating/cooling circuit e.g. an underfloor heating circuit. Suitable thermostatic valves must be used for cooling via an underfloor heating circuit. Ensure that the thermostatic valves can be opened via the AC signal or manually to enable cooling operation during the cooling period. Radiators, panel radiators and similar are not suitable for cooling mode.

To prevent the formation of condensate, all visible components e.g. pipes, pumps, etc. must be thermally insulated with vapour diffusion-proof material.

Note

For cooling mode in the following cases, a room temperature sensor must be installed and enabled:

- Room temperature-dependent cooling mode
- Weather-compensated cooling mode with room influence

Weather-compensated cooling mode

In weather-compensated cooling mode, the set flow temperature is calculated from the relevant set room temperature and the current outside temperature (long term average) according to the cooling curve. Its level and slope are adjustable.

Room temperature-dependent cooling mode

The set flow temperature is calculated from the differential of the set room temperature and the actual room temperature.

Cooling with an underfloor heating system

The underfloor heating system can be used for heating and for cooling buildings and rooms.

Surface temperature limits must be maintained to observe comfort criteria and to prevent condensation. Therefore, the surface temperature of an underfloor heating system in cooling mode must not fall below 20 °C.

Design information (cont.)

To prevent the formation of condensate on the surface of underfloor heating systems, install a contact humidistat (accessories) into the underfloor heating system flow. This safely prevents the formation of condensate, even if weather conditions change quite rapidly (e.g. during a thunderstorm).

The underfloor heating system should be sized in accordance with a flow/return temperature pair of approx. 14/18 °C.

The following table can be used to estimate the possible cooling capacity of an underfloor heating system.

The following applies in general:

The minimum flow temperature for cooling with an underfloor heating system and the minimum surface temperature are subject to the prevailing climatic conditions in the room (air temperature and relative humidity). These conditions must therefore also be taken into consideration during the engineering stage.

Estimated cooling capacity of an underfloor heating system depending on the floor covering and pipe spacing (assumed flow temperature approx. 16 °C, return temperature approx. 20 °C)

Flooring	Installation spacing	Tiles			Carpet		
		75	150	300	75	150	300
Cooling capacity with pipe diameter							
	-10 mm	40	31	20	27	23	17
	-17 mm	41	33	22	28	24	18
	-25 mm	43	36	25	29	26	20

Details accurate for

Room temperature 26 °C

Relative humidity 50 %

Dew point temperature 15 °C

7.14 Leak test on the refrigerant circuit

Heat pump refrigerant circuits containing a refrigerant with a CO₂ equivalent of 5 t or more must be tested regularly for tightness in accordance with EU Regulation No. 517/2014. In the case of hermetically sealed refrigerant circuits, this regular testing is required for a CO₂ equivalent of 10 t or more.

The intervals at which the refrigerant circuits will need to be tested depend on the level of CO₂ equivalent. If leak detection facilities are available on site, the test intervals are extended.

The Vitocal 150-A and Vitocal 151-A heat pumps have hermetically sealed refrigerant circuits. The CO₂ equivalent is below 10 t for all appliances.

A regular leak test of the refrigerant circuit is therefore **not** required.

7.15 Intended use

The appliance is only intended to be installed and operated in sealed unvented heating systems that comply with EN 12828, with due attention paid to the associated installation, service and operating instructions.

Depending on the version, the appliance can only be used for the following purposes:

- Central heating
- Central cooling
- DHW heating

The range of functions can be extended with additional components and accessories.

Intended use presupposes that a fixed installation in conjunction with permissible, system-specific components has been carried out.

Commercial or industrial usage for a purpose other than central heating/cooling or DHW heating shall be deemed inappropriate.

Incorrect usage or operation of the appliance (e.g. the appliance being opened by the system user) is prohibited and will result in an exclusion of liability. Incorrect usage also occurs if the components in the heating system are modified from their intended function.

Note

The appliance is intended exclusively for domestic or semi-domestic use, i.e. even users who have not had any instruction are able to operate the appliance safely.

Heat pump control unit

8.1 Layout and functions

Modular design

The control unit is integrated into the indoor unit.

Heat pump control unit (cont.)

The control unit comprises electronics modules and the HMI programming unit:

- HMI programming unit with 7-inch touchscreen and integral TCU communication module
- HPMU electronics module:
 - Connection of actuators
 - Connection of components and accessories via PlusBus and CAN bus
 - Power supply to accessories
- EHCU electronics module for instantaneous heating water heater and contact humidistat
- Status indicator (Lightguide) for operating and fault display

Programming unit

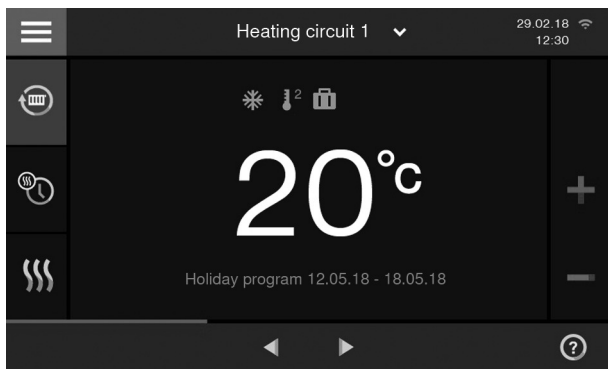

The control unit can be set to the following operating modes:

- Weather-compensated operation
 - The outside temperature sensor must be connected.
- Room temperature-dependent operation
- Easy operation through:
 - Touchscreen with graphic display and plain text
 - Large font and colour depiction for good contrast
 - Context-sensitive help texts
- Connectivity via:
 - Integral WiFi interface
 - Access point mode
 - Low power radio
- With digital time switch
- Touchscreen for:
 - Navigation
 - Settings
 - Confirmation
 - Help and additional information
 - Menu
- Adjustment of:
 - Set room temperature
 - Reduced
 - Normal
 - Comfort
 - Set cylinder temperature
 - One-off DHW heating
 - Operating programs for central heating and DHW heating
 - Time programs for central heating, DHW heating and DHW circulation
 - Comfort mode
 - Holiday program
 - Holiday at home
 - Heating curves
 - Hygiene function (increased DHW hygiene)
 - Parameter
 - Actuator tests
 - Test mode

- Display of:
 - Outside temperature
 - Heat generator flow temperature
 - Flow temperature, heating/cooling circuit with mixer
 - Set flow temperature
 - Cylinder temperature
 - Operating data
 - Energy consumption values (in the energy cockpit)
 - Diagnostic data
 - Fault messages
- Available languages:
 - Deutsch
 - Czech
 - Danish
 - English
 - French
 - Italian
 - Dutch
 - Polish
 - Slovak
 - Swedish
 - Estonian
 - Croatian
 - Latvian
 - Lithuanian
 - Norwegian
 - Bulgarian
 - Portuguese
 - Romanian
 - Russian
 - Serbian
 - Slovenian
 - Spanish
 - Finnish
 - Ukrainian
 - Hungarian

Heat pump control unit (cont.)

Functions

- Weather-compensated control of the flow temperature
- Control of 1 or 2 directly connected heating/cooling circuits without mixer
 - Or
 - In conjunction with external buffer cylinder:
 - Control of 1 heating/cooling circuit without mixer **and** up to 3 heating/cooling circuits with mixer
- Electronic maximum and minimum temperature limit
- Demand-dependent heating/cooling circuit pump and compressor shutdown
- Variable heating limit setting
- Automatic winter/summertime changeover
- Individually programmable switching times for heating/cooling operation and DHW heating:
 - Up to 4 time phases per day
- Frost protection monitoring for the system
- Integral diagnostic system
- Service indicator
- Commissioning via commissioning assistant
- Cylinder temperature controller with priority control
- Hygiene function for DHW heating (short term heating to a higher temperature)
- Screed drying program simultaneously for all heating/cooling circuits (selection of 6 stored programs)
- External heating circuit hook-up (weather-compensated control of flow temperature for up to 4 heating/cooling circuits in conjunction with room thermostat)
- Optimised energy management, e.g. in conjunction with photovoltaic system, power storage system
- Setting of low-noise mode for the outdoor unit
- Connection option for extension modules

Information on the PlusBus subscribers

Up to 3 EM-M1 or EM-MX extensions (ADIO electronics module) can be connected to the control unit.

PlusBus cable (unshielded)

- 2-core
- Cable cross-section: 0.34 mm²
- Max. total length: 50 m

Frost protection function

- The frost protection function will start when the outside temperature falls below approx. +1 °C.
 - With active frost protection, the secondary pump is switched on. The reduced flow temperature is set.
- If the cylinder temperature is < 5 °C, the DHW cylinder is heated to 20 °C. If the system is set to weather-compensated control with room temperature hook-up, the frost protection function will not be active for the heating circuits (if the contact is not assigned). In such cases, frost protection for the heating circuit must be provided on site.
- The frost protection function will stop when the outside temperature exceeds approx. +3 °C.

Setting the heating curves (slope and level)

The flow temperature of the heating/cooling circuits without mixer **and** the flow temperature of the heating/cooling circuits with mixer (in conjunction with mixer extension kit) are weather-compensated. The flow temperature of the heat pump is therefore automatically regulated to between 0 to 40 K above the currently required set flow temperature (delivered condition 8 K).

The flow temperature required to reach a specific room temperature depends on the heating system and the thermal insulation of the building to be heated.

By adjusting the heating curves, the flow temperature in the secondary circuit is matched to these conditions.

The flow temperature is restricted at the upper end of the scale by the temperature limiter and the maximum temperature set at the electronic maximum temperature limiter.

The flow temperature in the heating/cooling circuits cannot exceed the heat pump flow temperature.

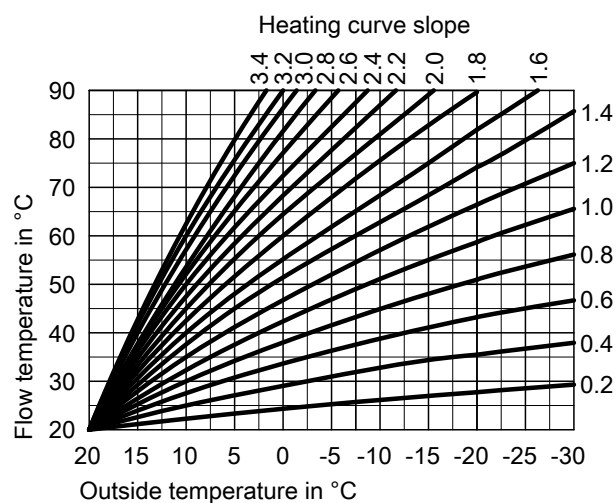

Systems with external buffer cylinder

When using an external buffer cylinder, a buffer temperature sensor must be installed. This buffer temperature sensor is connected to the heat pump control unit.

Heat pump control unit (cont.)

Outside temperature sensor

Installation location

- North or north-west facing wall of the building
- 2 to 2.5 m above the ground; for multi storey buildings in the upper half of the second floor

Connection

- 2-core lead, length up to 35 m with a cross-section of 1.5 mm² (copper)
- Never route this cable immediately next to 230/400 V cables.

Specification

IP rating	IP 43 to EN 60529; ensure through design/installation.
Sensor type	Viessmann NTC 10 kΩ at 25 °C
Permissible ambient temperature during operation, storage and transport	-40 to +70 °C

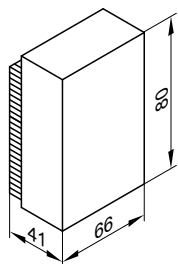

8.2 Specification, heat pump control unit

Rated voltage	230 V~
Rated frequency	50 Hz
Rated current	6 A
Protection class	I
Permissible ambient temperature	
- Operation	5 to +35 °C Installation in living spaces or boiler rooms (standard ambient conditions)
- Storage and transport	-20 to +65 °C
Electronic temperature limiter setting (heating mode)	91 °C (cannot be changed)
Setting range for DHW temperature	10 to 60 °C: On indoor units with integral DHW cylinder, up to 70 °C
Setting range for heating curve	
Slope	0.2 to 3.5
Level	-13 to 40 K
Communication module (integral)	
WiFi frequency band	2400 to 2483.5 MHz
Max. transmission power	+ 17 dBm
Zigbee frequency band	2400 - 2483.5 MHz
Max. transmission power	+ 10 dBm
Supply voltage	24 V _{DC}
Power consumption	4 W

Control unit accessories

9.1 Overview

Accessories	Part no.	Vitocal 150-A	Vitocal 151-A
Photovoltaics: See page 97 onwards.			
3-phase electricity meter			
– Balancing	ZK06026	X	X
– Non-balancing	ZK06027	X	X
Bus cables: See page 97 onwards.			
Bus communication cable, indoor/outdoor unit			
– Length 5 m	ZK06216	X	X
– Length 15 m	ZK06217	X	X
– Length 30 m	ZK06218	X	X
Bus cable for networking bus subscribers			
– Length 5 m	ZK06219	X	X
– Length 15 m	ZK06220	X	X
– Length 30 m	ZK06221	X	X
Sensors: See page 98 onwards.			
Immersion temperature sensor (NTC 10 kΩ)	7438702	X	X
Extension for heating circuit control unit: See page 98 onwards.			
Contact thermostat	ZK04647	X	X
Contact thermostat	7151729	X	X
Immersion thermostat	7151728	X	X
EM-MX mixer extension kit (mixer mounting)	Z017409	X	X
EM-M1 mixer extension kit (wall mounting)	Z017410	X	X

Note

The following description of control unit accessories lists all functions and connections of each control unit accessory. Not all of these functions and connections are available for every heat pump.

9.2 Photovoltaics

3-phase electricity meter

Part no. ZK06026

Phase-balancing bidirectional meter

- With CAN bus interface
- To ensure the heat pump makes optimum use of the power generated on site by the photovoltaic system

3-phase electricity meter

Part no. ZK06027

Non-balancing bidirectional meter: The currents in the same metering direction are totalled.

- With CAN bus interface
- To ensure the heat pump makes optimum use of the power generated on site by the photovoltaic system

9.3 Bus cables

Bus communication cables

Length	Part no.
5 m	ZK06217
15 m	ZK06218
30 m	ZK06219

Fully wired, shielded CAN bus communication cable between the outdoor and indoor unit

Bus connecting cable

Length	Part no.
5 m	ZK06219
15 m	ZK06220
30 m	ZK06221

Fully wired, shielded CAN bus connecting cable for networking bus subscribers in the system network, e.g. Vitoair, Vitocal, Vitocharge, etc.

9.4 Sensors

Immersion temperature sensor

Part no. 7438702

- To capture the temperature in a sensor well
- For installation in a DHW cylinder or heating water buffer cylinder

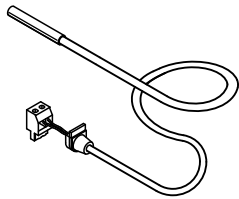

Specification

Lead length	5.8 m, fully wired
IP rating	IP 32 to EN 60529; ensure through design/installation
Sensor type	Viessmann NTC 10 kΩ at 25 °C
Permissible ambient temperature	
– Operation	0 to +90 °C
– Storage and transport	–20 to +70 °C

9.5 Heating circuit control unit extension

Contact thermostat

Part no. ZK04647

Can be used as a maximum temperature limiter for underfloor heating systems (only in conjunction with metal pipes). The temperature limiter is fitted to the heating flow. If the flow temperature is too high, the temperature limiter switches off the heat generator.

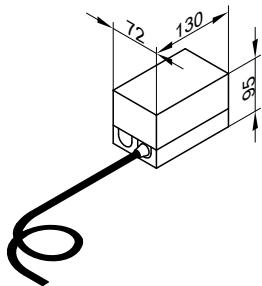

Specification

Lead length	1.5 m
Setting range	30 to 80 °C
Switching differential	6.5 K ±2.5 K
Breaking capacity	6(1.5) A, 250 V~
Setting scale	Inside the enclosure
Protection rating to EN 60529	IP 41

Contact thermostat

Part no. 7151729

May be used as a maximum temperature limiter for underfloor heating systems (only in conjunction with metal pipes). The temperature limiter is integrated into the heating flow. If the flow temperature is too high, the temperature limiter switches off the heating circuit pump.

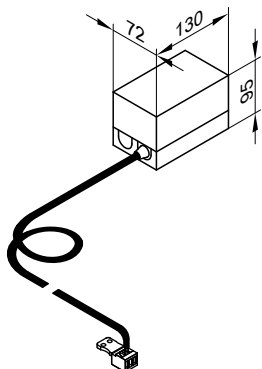

Specification

Lead length	4.2 m, fully wired
Setting range	30 to 80 °C
Switching differential	Max. 14 K
Breaking capacity	6(1.5) A, 250 V~
Setting scale	Inside the casing
DIN reg. no.	DIN TR 1168

Immersion thermostat

Part no. 7151728

May be used as a maximum temperature limiter for underfloor heating systems.

The temperature limiter is integrated into the heating flow. If the flow temperature is too high, the temperature limiter switches off the heating circuit pump.

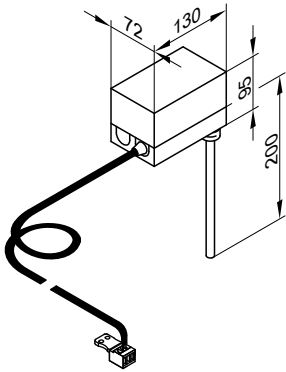

Specification

Cable length	4.2 m, fully wired
Setting range	30 to 80 °C
Switching differential	Max. 11 K
Breaking capacity	6(1.5) A, 250 V~
Setting scale	Inside the enclosure
Stainless steel sensor well (male thread)	R ½ x 200 mm
DIN reg. no.	DIN TR 1168

EM-MX mixer extension kit with integral mixer motor

Part no. Z017409

PlusBus subscriber

Components:

- Mixer PCB (ADIO electronics module) with mixer motor for Viessmann mixer DN 20 to DN 50 and R ½ to R 1¼
- Flow temperature sensor (contact temperature sensor) with connecting lead and plug
- Plug for connecting the heating circuit pump
- Power cable (3.0 m long) with plug
- PlusBus connecting lead (3.0 m long) with plug
- Option to connect immersion temperature sensor low loss header (separate accessory)

The mixer motor is mounted directly onto the Viessmann mixer DN 20 to DN 50 and R ½ to R 1¼.

Mixer PCB with mixer motor

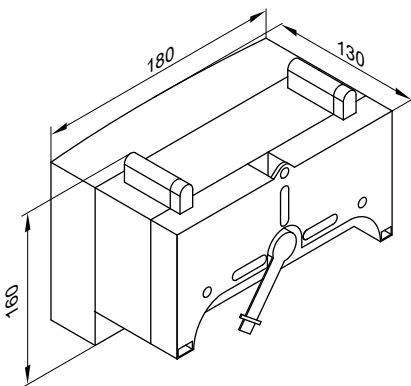

Specification - Mixer PCB with mixer motor

Rated voltage	230 V~
Rated frequency	50 Hz
Rated current	2 A
Power consumption	5.5 W
IP rating	IP 20D to EN 60529; ensure through design/installation.
Protection class	I
Permissible ambient temperature	
– Operation	0 to +40 °C
– Storage and transport	–20 to +65 °C
Rated relay output breaking capacity	
– Heating circuit pump [20]	1 A, 230 V~
– Mixer motor [52]	0.1 A, 230 V~
Torque	3 Nm
Required runtime of the mixer motor for 90° <	Approx. 120 s

Flow temperature sensor (contact temperature sensor)

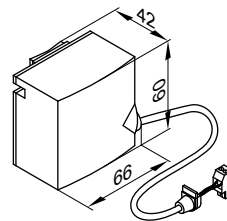

Secured with a tie.

Flow temperature sensor specification

Lead length	2.0 m, fully wired
IP rating	IP 32D to EN 60529; ensure through design/installation.
Sensor type	Viessmann NTC 10 kΩ at 25 °C
Permissible ambient temperature	
– Operation	0 to +120 °C
– Storage and transport	–20 to +70 °C

EM-M1 mixer extension kit for separate mixer motor

Part no. Z017410

PlusBus subscriber

For connecting a separate mixer motor

Components:

- Mixer PCB (ADIO electronics module) for connecting a separate mixer motor
- Flow temperature sensor (contact temperature sensor) with connecting lead and plug
- Plug for connecting the heating circuit pump and the mixer motor
- Power cable (3.0 m long) with plug
- PlusBus connecting lead (3.0 m long) with plug
- Option to connect immersion temperature sensor low loss header (separate accessory)

Mixer PCB

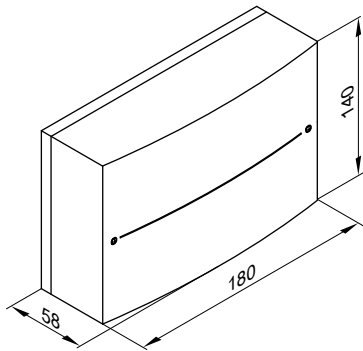

Mixer PCB specification

Rated voltage	230 V~
Rated frequency	50 Hz
Rated current	2 A
Power consumption	1.5 W

IP rating	IP 20D to EN 60529; ensure through design/installation.
Protection class	I
Permissible ambient temperature	
– Operation	0 to +40 °C
– Storage and transport	–20 to +65 °C
Rated relay output breaking capacity	
– Heating circuit pump [20]	1 A, 230 V~
– Mixer motor [52]	0.1 A, 230 V~
Required runtime of the mixer motor for 90° <	Approx. 120 s

Flow temperature sensor (contact temperature sensor)

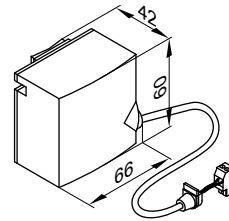

Secured with a tie.

Flow temperature sensor specification

Lead length	5.8 m, fully wired
IP rating	IP 32D to EN 60529; ensure through design/installation.
Sensor type	Viessmann NTC 10 kΩ at 25 °C
Permissible ambient temperature	
– Operation	0 to +120 °C
– Storage and transport	–20 to +70 °C

Keyword index

4		D	
4-way diverter valve.....	27	Delivered condition	
A		– Vitocal 150-A.....	6
Accessories		– Vitocal 151-A.....	17
– DHW heating.....	47, 53	Design casing.....	74
ADIO electronics module.....	95	Design guide.....	87
Advanced Acoustic Design+.....	6, 16	Design information.....	66
Air discharge.....	71	DHW circulation pump.....	89
Air intake.....	71	DHW connection.....	89
Air intake temperature.....	8, 10, 12	DHW cylinders.....	90
Air short circuit.....	66	DHW demand.....	86, 91
Ambient temperatures.....	76	DHW heating system examples.....	92
Anti-vibration feet.....	67, 71	Dimensions	
Anti-vibration mounts.....	68	– Indoor unit.....	9, 11, 13, 19, 21, 23
Application.....	93	– Indoor unit, Vitocal 150-A.....	14
Application limits		– Indoor unit, Vitocal 151-A.....	25
– Vitocal 150-A.....	15	– Outdoor unit.....	9, 11, 13, 19, 21, 23
– Vitocal 151-A.....	26	– Vitocal 150-A.....	14, 15
Application procedure (details).....	66	– Vitocal 150-A outdoor unit.....	15
Automatic thermostatic mixing valve.....	90	– Vitocal 151-A.....	25, 26
B		– Vitocal 151-A outdoor unit.....	26
Blocking time.....	86	Directivity.....	82
Bracket for wall mounting.....	76	Drain & fill facility.....	80
Bracket set.....	67	Drain for condensate.....	76
Buffer cylinder.....	87	Drain hose safety valve.....	15
Bus cables.....	97	Drain valve.....	90
Bus communication cables.....	97	Drinking water filter.....	89, 90
C		Duel mode operation.....	91
Cable entry.....	79	E	
Cable entry through the floor plate.....	79	EC fan.....	27
Cable length.....	81, 82	Electrical connections.....	80
CAN bus, communication cable.....	28	Electrical demand.....	66
Cellar shaft.....	66	Electrical values	
Check valve.....	89	– Indoor unit.....	8, 10, 12, 18, 20, 22
CO ₂ equivalent.....	93	– Outdoor unit.....	8, 10, 12, 18, 20, 22
Coastal siting.....	67	Electric cables.....	74, 75, 76
Compressor.....	27	Electricity meter.....	80, 81
Condensate.....	68, 93	Electricity meter 3-phase.....	97
Condensate drain.....	28, 76	Electric ribbon heater.....	68
– Via soakaway.....	72	Energy efficiency class.....	9, 11, 13
– Via waste water system.....	73	Evaporator.....	27
Condenser.....	27	Expansion vessel.....	6, 16
Connecting cables.....	74, 75, 76	F	
Connecting cables for indoor/outdoor unit.....	81	Fan.....	27
Connection, indoor/outdoor units.....	79	Federal tariffs [Germany].....	66
Connection cables.....	81	Fill & drain facility.....	80
Connections.....	9, 11, 13	Fill water.....	88
Connection set.....	79, 80	Finished floor.....	77
Contact humidistat.....	93	Fixing materials.....	67
Contact thermostat.....	97, 98	Flat roof installation.....	67
Control circuit.....	80	Floor load.....	79
Control unit.....	93	Floorstanding installation.....	67
Control unit accessories.....	97	Flow	
Cooling capacity for underfloor heating systems.....	93	– DHW cylinder.....	15, 25
Cooling mode.....	92	– Outdoor unit.....	15, 25, 28
– Room temperature-dependent.....	92	– Secondary circuit.....	15, 25
– Weather-compensated.....	92	Flow regulating valve.....	89, 90
Cooling with underfloor heating.....	92	Flow temperature.....	6, 16
Cylinder temperature.....	91	– Secondary circuit.....	91
		Foundation.....	71, 72, 74, 75
		Frost protection for foundations.....	71, 72, 74, 75
		Frost protection function.....	95
		Fuses.....	80
		G	
		Gravel bed for condensate.....	71, 72, 74, 75, 76

Keyword index

H		O	
Heat exchanger surface area.....	90	Operation.....	91
Heating curves.....	95	– Mono energetic.....	86
Heating output.....	85	– Mono mode.....	85
Heating water.....	8, 10, 12	Outdoor unit	
Heating water buffer cylinder.....	6	– Cable lengths.....	81
– Connected in parallel.....	87	– Dimensions.....	9, 11, 13, 19, 21, 23
Heating water flow.....	9, 11, 13, 19, 21, 23	– Electrical values.....	8, 10, 12, 18, 20, 22
Heating water quality.....	88	– Floorstanding installation with support.....	74, 75
Heating water return.....	9, 11, 13, 19, 21, 23	– Wall mounting with bracket.....	76
Heat load.....	85	– Weight.....	69
Heat pump control unit.....	6, 16, 93	Outdoor unit floorstanding installation.....	74, 75
– Power cable.....	81	Outdoor unit installation	
Heat pump sizing.....	85	– Supports for floorstanding installation.....	67
High pressure fault.....	66	Outside temperature sensor.....	80, 81, 96
Hydraulic conditions, secondary circuit.....	87	Oversizing.....	85
Hydraulic connections.....	9, 11, 13	Overview	
Hydraulic connection set.....	79	– Control unit accessories.....	97
Hydro AutoControl.....	87		
I		P	
Immersion heater.....	51, 52, 58, 65	Performance data, heating.....	8, 10, 12, 18, 20, 22
Immersion thermostat.....	97, 99	Performance graph.....	29, 32
Impressed current anode.....	53, 59, 66	Permissible operating pressure.....	9, 11, 13
Indoor unit		Pipe separator.....	90
– Cable lengths.....	81	Pipe spacing in underfloor heating systems.....	93
– Dimensions.....	9, 11, 13, 19, 21, 23	Platform for unfinished floors.....	77
– Electrical values.....	8, 10, 12, 18, 20, 22	PlusBus.....	95
– Installation height.....	77	Power cable.....	28, 81
Installation, outdoor unit		– Indoor unit.....	81
– Bracket set for wall mounting.....	67	– Outdoor unit.....	82
Installation location.....	66	Power consumption.....	8, 10, 12, 18, 20, 22
Installation types.....	67	Power-OFF.....	66, 80, 81, 85
Instantaneous heating water heater.....	6, 16, 80	Power-OFF period.....	66
– Power cable.....	81	Power-OFF time.....	85, 86
– Specification.....	8, 10, 12, 18, 20, 22	Power supply.....	66
Integral DHW cylinder.....	19, 21, 23	Power tariffs.....	66
Intended use.....	93	Pressure gauge connection.....	89, 90
Inverter.....	27	Pressure points.....	79
		Pressure reducer.....	89, 90
L		Primary inlet temperature.....	91
Leak detection.....	93	Product information	
Leak test.....	93	– Accessories.....	47
Level.....	95	– Vitocal 150-A.....	6
Lightning protection.....	68	– Vitocal 151-A.....	16
Likelihood of corrosion.....	67	Product types.....	5
		Programming unit.....	94
M		R	
Max. connection line length.....	19, 21, 23	Recommended power cables.....	81
Minimum clearances		Refrigerant.....	6, 16
– Indoor unit.....	78	Refrigerant circuit.....	9, 11, 13, 19, 21, 23
– Outdoor unit.....	70	Requirements	
Minimum flow rate.....	87, 88	– Electrical installation.....	80
Minimum pipe diameters.....	88	– Installation room.....	76
Minimum room height.....	77	– Siting.....	76
Minimum system volume.....	87	Residual head.....	15, 26
Mixer extension		– Vitocal 151-A.....	26
– Integral mixer motor.....	99	Return	
– Separate mixer motor.....	100	– DHW cylinder.....	15, 25
Mixer extension kit.....	97	– Outdoor unit.....	15, 25, 28
– Integral mixer motor.....	99	– Secondary circuit.....	15, 25
– Separate mixer motor.....	100	Return, DHW cylinder.....	9, 11, 13, 19, 21, 23
Mobile data transfer.....	9, 11, 13	Reversible cooling mode.....	92
Mono energetic operation.....	86, 91	Room height.....	77
Mono mode operation.....	85, 91	Room temperature-dependent cooling mode.....	92
		Room temperature sensor	
N		– Cooling mode.....	92
Noise.....	85		
Noise emissions.....	82		
Non-return valve.....	89, 90		

Keyword index

S

Safety valve.....	6, 16, 27, 89, 90
Safety zone.....	69
Secondary pump.....	6, 16
Selecting a DHW cylinder.....	90
Sensors.....	98
Service link.....	6, 16
Siting.....	67
– Between walls.....	66
– Indoor unit.....	76
– In recesses.....	66
– Outdoor unit.....	66
Sizing DHW cylinders.....	90
Sizing heat pump.....	85
Sizing the heat pump.....	85
Slope.....	95
Smart Grid.....	86
Solar heat exchanger set.....	52
Sound absorption.....	83
Sound emission.....	82
Sound emissions.....	85
Sound power.....	9, 11, 13, 19, 21, 23
Sound power level.....	82
Sound pressure level.....	82, 83
Sound propagation.....	66
Sound reflection.....	82, 83
Sound reflections.....	66
Sound source.....	82
Specification	
– Control unit.....	96
– Vitocal 150-A.....	8
– Vitocal 200-A.....	18
Standard heat load of the building.....	85
Structure-borne noise.....	85
Suction gas cooler.....	27
Supplement for DHW heating.....	86
Supplement for setback mode.....	86
Support.....	71
Support for floorstanding installation.....	67

T

Technical connection requirements.....	80
Temperature sensors	
– Outside temperature sensor.....	96
Temperature spread.....	91
Thermostat	
– Contact temperature.....	98
– Immersion temperature.....	99
Thermostatic mixing valve, automatic.....	89, 90
Top-up water.....	88
Total weight.....	9, 11, 13, 19, 21, 23
Type overview.....	7, 17

V

Valve, 4/3-way.....	6, 16
Vibration isolation.....	68
ViCare.....	6, 16

W

Wall duct.....	80
Wall mounting.....	76
Wall sealing flange.....	79
Water quality.....	88
Weather-compensated control	
– Frost protection function.....	95
Weather-compensated control unit	
– Functions.....	95
– Programming unit.....	94
Weather-compensated cooling mode.....	92
Weather influences.....	68
Weatherproofing.....	68
Weight.....	69
Wind direction.....	67
Wind loads.....	68
Wiring diagram.....	80

Subject to technical modifications.

Viessmann Climate Solutions SE
35108 Allendorf / Germany
Telephone: +49 6452 70-0
Fax: +49 6452 70-2780
www.viessmann.com

Viessmann Limited
Hortonwood 30, Telford
Shropshire, TF1 7YP, GB
Telephone: +44 1952 675000
Fax: +44 1952 675040
E-mail: info-uk@viessmann.com

6179959