

# OWNER'S MANUAL

How to operate your Demand Controlled  
Water Softener

# VIESSMANN

**Model VS 34**  
**Model VS 74**  
**Model VS 87**  
**Model VS 124**

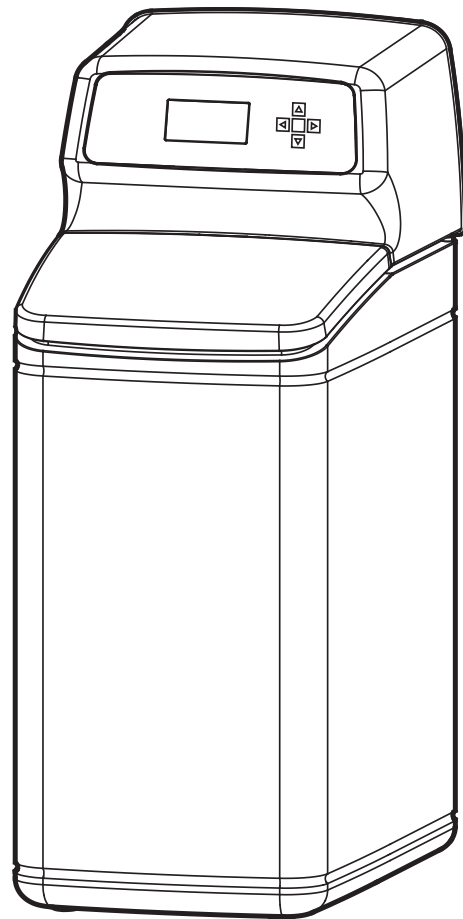

	Page
English <b>Owner's Manual</b> <b>Viessmann</b> <b>Water Softener</b> . . . . .	1
Français <b>Guide d'utilisation</b> <b>Adoucisseur d'eau</b> <b>Viessmann</b> . . . . .	33
Nederlands <b>Gebruikershandleiding</b> <b>Viessmann</b> <b>Waterontharder</b> . . . . .	65
Italiano <b>Manuale dell'utente</b> <b>Addolcitore d'acqua</b> <b>Viessmann</b> . . . . .	97

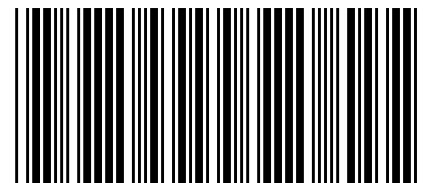

# Specifications & Dimensions

Model	VS 34	VS 74	VS 87	VS 124
Model Code	VS34	VS74	VS87	VS124
Rated Softening Capacity (mol @ kg Salt Dose)	2.4 @ 0.4 3.4 @ 0.7 4.5 @ 1.3	4.4 @ 0.65 7.4 @ 1.3 10.3 @ 3.6	5.8 @ 0.84 8.7 @ 1.4 11.7 @ 2.6	6.82 @ 1.09 12.4 @ 2.1 18.0 @ 3.9
Rated Efficiency (mol per kg @ Min. Salt Dose)	6.00	6.77	6.90	6.26
Service Flow Rate (L/min.)	15	24	28	27
Pressure Drop at Service Flow Rate (bar)	0.23	0.71	1	1
Intermittent Flow Rate (L/min.) @ 1 bar	33	28	28	27
Amount of High Capacity Resin (liters)	8.9	14.2	17.2	23.1
Water Used during Recharge @ Min. Salt Dose (liters)	47	66	104	114
Water Used during Recharge @ Max. Salt Dose (liters)	44	68	106	103
Water Supply Max. Clear Water Iron (ppm)	3	4	5	5
Min.-Max. Working Pressure (bar)	1.4 - 8.5			
Min.-Max. Operating Temperature (°C)	4 - 49			
Max. Flow Rate (L/min.) to Drain during Recharge	6.8			

**Variable Salt Dose:** The salt dose is selected by the electronic controls at regeneration time based on the amount needed.

Model	Nominal Resin Tank Size	Salt Storage Capacity	Dimension A	Dimension B	Dimension C
VS 34	22.9 x 35.6 cm	19 kg	41.5 cm	29.1 cm	55 cm
VS 74	20.3 x 63.5 cm	25 kg	70 cm	58.4 cm	83.8 cm
VS 87	20.3 x 88.9 cm	68 kg	94 cm	83.8 cm	106.7 cm
VS 124	20.3 x 101.6 cm	79 kg	105.4 cm	95.3 cm	119.4 cm

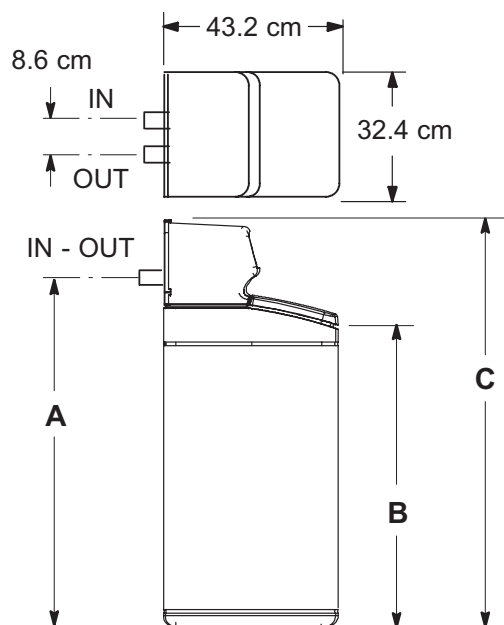

**FIG. 1**

# Installation Requirements

## LOCATION REQUIREMENTS

Consider all of the following when selecting an installation location for the water softener.

- Do not locate the water softener where freezing temperatures occur. Do not attempt to treat water over 49°C. Freezing temperatures or hot water damage voids the warranty.
- To condition all water in the home, install the water softener close to the water supply inlet, and upstream of all other plumbing connections, except outside water pipes. Outside faucets should remain on hard water to avoid wasting conditioned water and salt.
- A nearby drain is needed to carry away recharge drain water. Use a floor drain, laundry tub, sump, standpipe, or other options (check your local codes). See "Air Gap Requirements" and "Valve Drain Requirements" sections.
- The water softener works on 24V DC electrical power, supplied by a direct plug-in power supply (included). Provide a nearby a 220-240V, 50 Hz electrical outlet, in accordance with national and local codes.
- Always install the water softener between the water inlet and water heater. Any other installed water conditioning equipment should be installed between the water inlet and water softener (See Figure 3 below).
- Avoid installing in direct sunlight. Excessive sun heat may cause distortion or other damage to non-metallic parts.

## PLUMBING CODES

All plumbing must be completed in accordance with national, state and local plumbing codes.

## AIR GAP REQUIREMENTS

A drain is needed for recharge water (See Figure 2). A floor drain, close to the water softener, is preferred. A laundry tub, standpipe, etc. are other drain options. Secure valve drain hose in place. Leave an air gap of 4 cm between the end of the hose and the drain. This gap is needed to prevent backflow of sewer water into the water softener. Do not put the end of the drain hose into the drain.

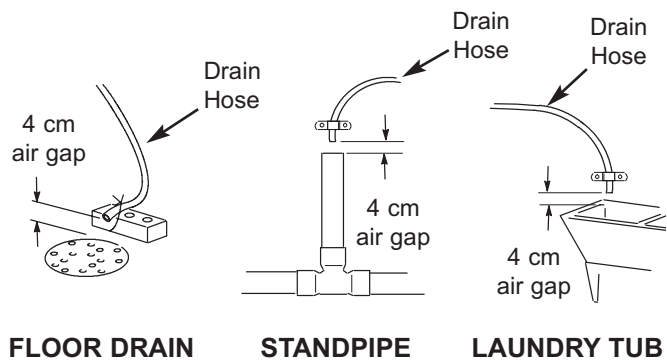

FIG. 2

## THE PROPER ORDER TO INSTALL WATER TREATMENT EQUIPMENT

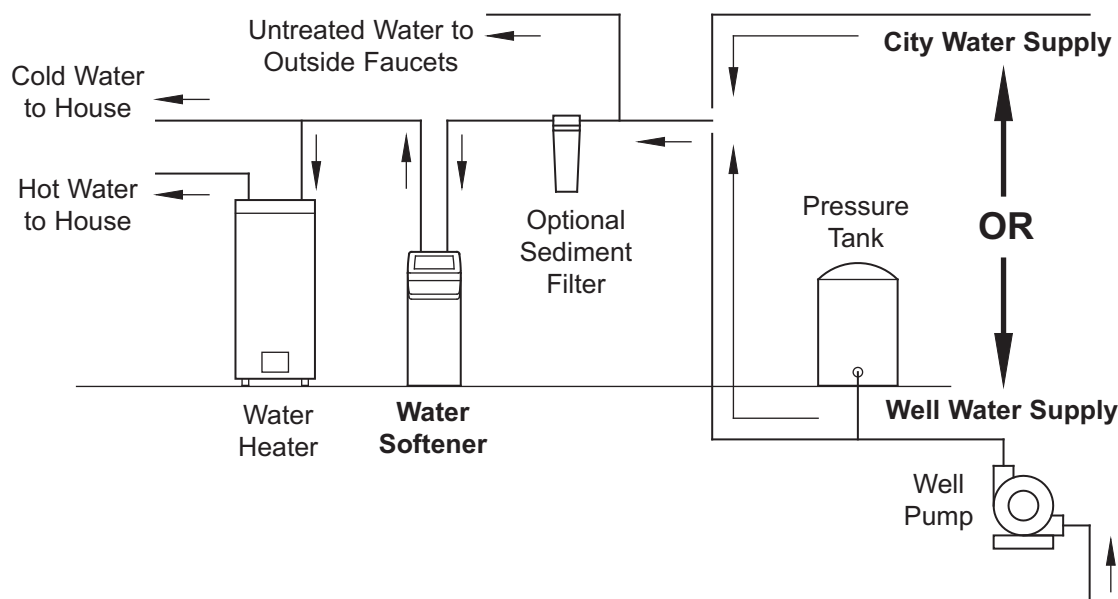

FIG. 3

# Installation Requirements

## VALVE DRAIN REQUIREMENTS

Using the flexible drain hose (included), measure and cut to the length needed. Flexible drain hose is not allowed in all localities (check your plumbing codes). If local codes do not allow use of a flexible drain hose, a rigid valve drain run must be used. Purchase a compression fitting (1/4 NPT x 1.25 cm minimum tube) and 1.25 cm tubing from your local hardware store. Plumb a rigid drain as needed (See Figure 5).

**NOTE:** Avoid drain hose runs longer than 9 meters.  
Avoid elevating the hose more than 2.5 meters above the floor. Make the valve drain line as short and direct as possible.

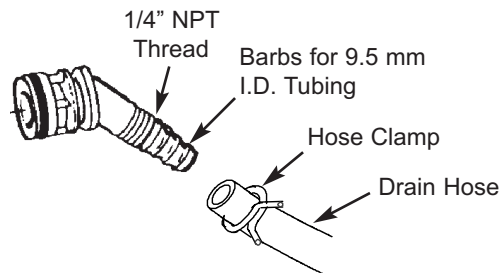

FIG. 4

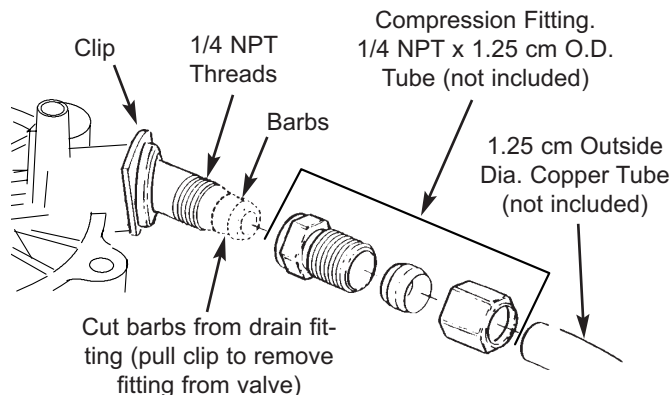

FIG. 5

## INLET / OUTLET PLUMBING OPTIONS

Always install either a single bypass valve (provided), as shown in Figure 6, or, if desired, parts for a 3 valve bypass system (not included) can be purchased and assembled, as shown in Figure 7. Bypass valves allow you to turn off water to the softener for maintenance if needed, but still have water in house pipes. Pipe fittings must be 1.9 cm minimum.

Use:

- Copper pipe
- Threaded pipe
- PEX (Crosslinked Polyethylene) pipe
- CPVC plastic pipe
- Other pipe approved for use with potable water

**IMPORTANT:** Do not solder with plumbing attached to installation adaptors and single bypass valve. Soldering heat will damage the adaptors and valve.

### SINGLE BYPASS VALVE

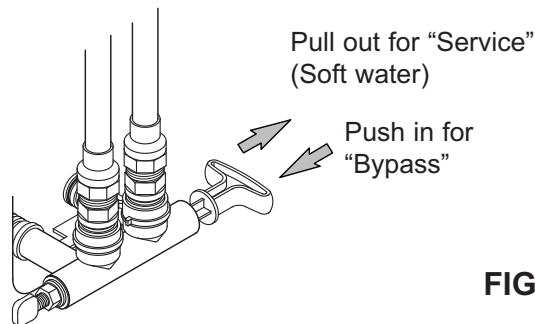

FIG. 6

### 3 VALVE BYPASS

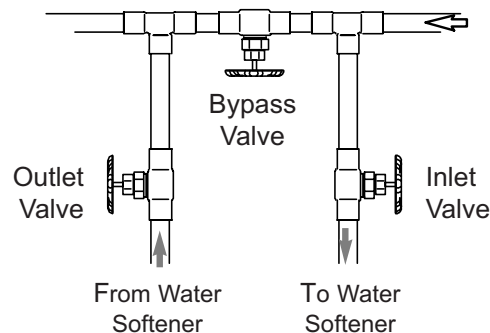

FIG. 7

# Installation Instructions

## TYPICAL INSTALLATION

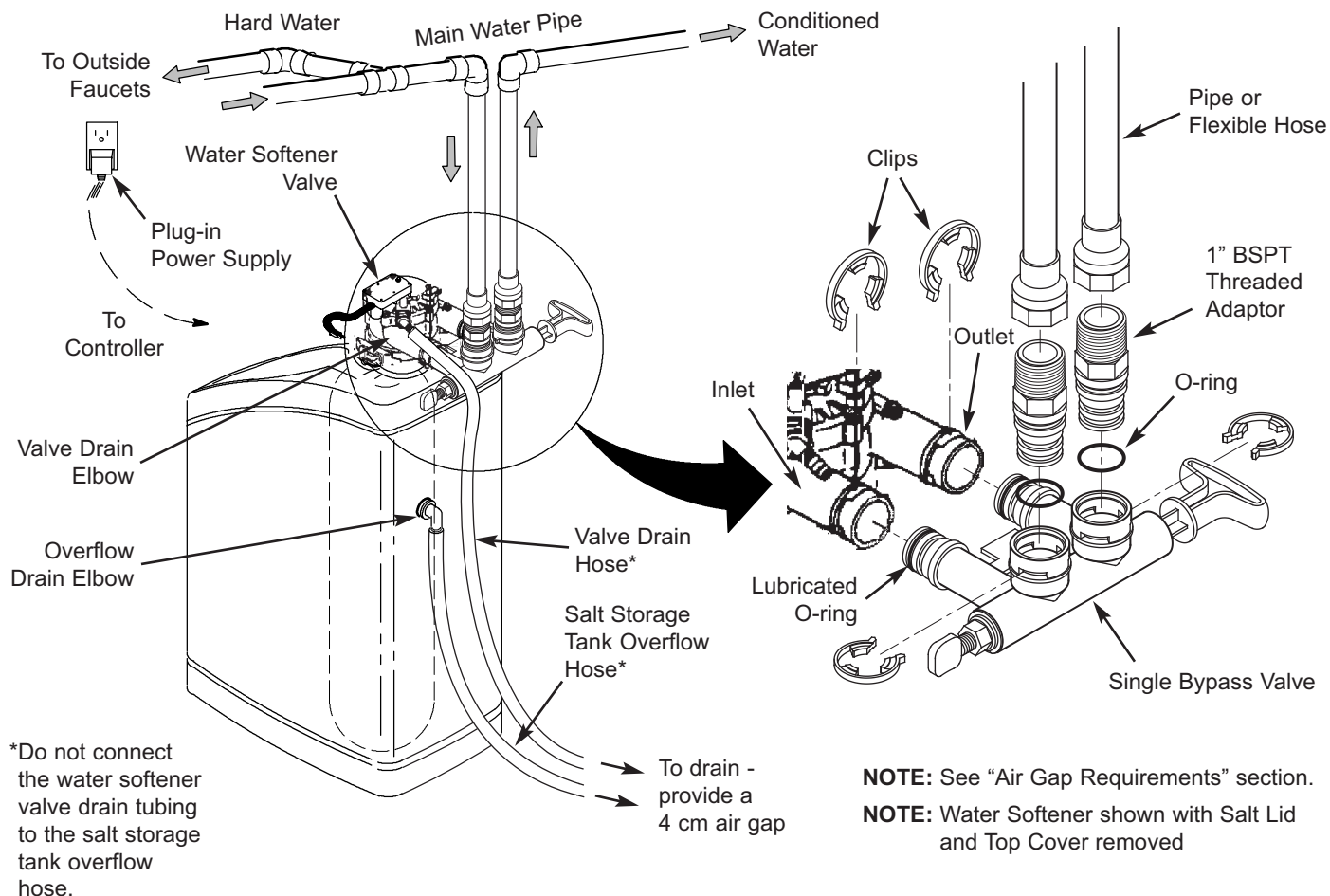

FIG. 8

## TURN OFF WATER SUPPLY

1. Close the main water supply valve, located near the well pump or water meter.
2. Shut off the electric or fuel supply to the water heater.
3. Open all faucets to drain all water from house pipes.

**NOTE:** Be sure not to drain water from the water heater, as damage to the water heater elements could result.

## ASSEMBLY

1. Viessmann softeners are factory assembled. During installation, remove the salt lid and set it aside to prevent damage. Check the brinewell to be sure it is secured and vertical (See Figure 11). Slide the faceplate cover forward to expose the softener valve assembly.

2. Lift the brine valve out of the brinewell. Make sure the float stem is parallel to the stand tube so the seals will seat properly during operation. Place the brine valve back into the bottom of the brinewell and reinstall the brinewell cover.
3. Install the brine tank overflow grommet and elbow into the 2 cm diameter hole in the back of the salt storage tank wall.

## MOVE THE UNIT INTO PLACE

1. Move the water softener into the desired location. Set it on a solid, level surface.

**IMPORTANT:** Do not place shims directly under the salt storage tank to level the softener. The weight of the tank, when full of water and salt, may cause the tank to fracture at the shim.

continued on next page

# Installation Instructions

continued from previous page

2. Visually check and remove any debris from the water softener valve inlet and outlet ports.
3. Make sure the turbine assembly spins freely in the "out" port of the valve (See Figure 9).
4. If not already done, put a light coating of silicone grease on the single bypass valve o-rings.
5. Push the single bypass valve into the softener valve as far as it will go. Snap the two large holding clips into place, from the top down as shown in Figures 12 & 13.

**IMPORTANT:** Be sure the clips snap firmly into place so the single bypass valve will not pull out.

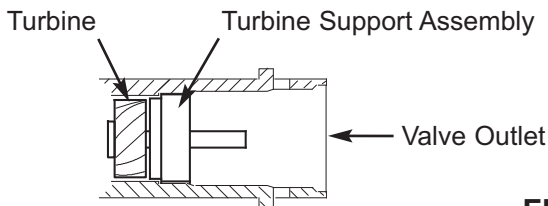

**FIG. 9**

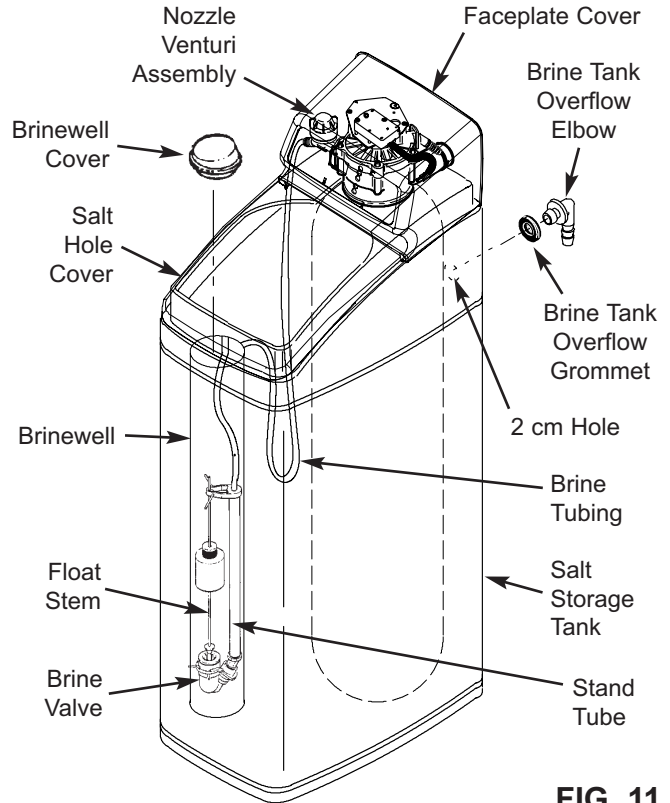

**FIG. 11**

## COMPLETE INLET AND OUTLET PLUMBING

Measure, cut, and loosely assemble pipe and fittings from the main water pipe to the inlet and outlet ports of the water softener valve. Be sure to keep fittings fully together, and pipes squared and straight.

Be sure hard water supply pipe goes to the water softener valve inlet side.

**NOTE:** Inlet and outlet are marked on the water softener valve. Trace the water flow direction to be sure hard water is to inlet.

**IMPORTANT:** Be sure to fit, align and support all plumbing to prevent putting stress on the water softener valve inlet and outlet. Undue stress from misaligned or unsupported plumbing may cause damage to the valve.

Complete the inlet and outlet plumbing for the type of pipes you will be using.

## ALTERNATE BYPASS VALVE INSTALLATION

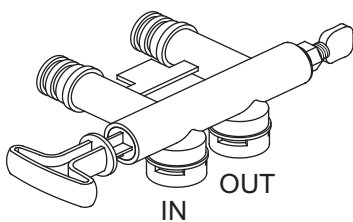

If connecting to floor level plumbing, install the bypass valve turned downward, as shown.

**FIG. 10**

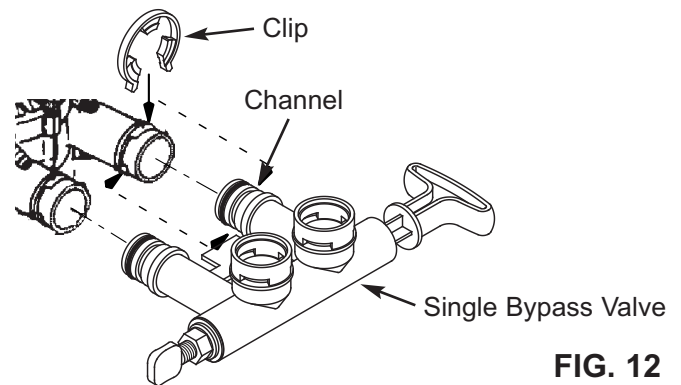

**FIG. 12**

### Correct Assembly

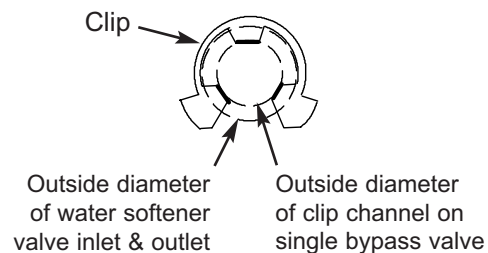

**FIG. 13**

**NOTE:** Be sure all 3 tabs of the clip go through the matching holes on the water softener valve inlet or outlet, and fully into the channel on the single bypass valve. Make sure that the tabs are fully seated.

# Installation Instructions

## COLD WATER PIPE GROUNDING

**CAUTION:** The house cold water pipe (metal only) is often used as a ground for the house electrical system. The 3-valve bypass type of installation, shown in Figure 7, will maintain ground continuity. If you use a plastic bypass valve at the unit, continuity is broken. To restore the ground, do the following:

1. Install a #4 copper wire across the removed section of main water pipe, securely clamping it at both ends (See Figure 14) - parts not included.

**NOTE:** Check local plumbing and electrical codes for proper installation of the ground wire. The installation must conform to them. Consult with your licensed plumber.

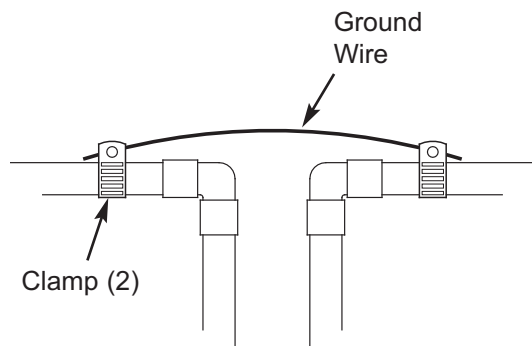

FIG. 14

## INSTALL VALVE DRAIN HOSE

**NOTE:** See valve drain options on pages 3 & 4.

1. Measure, cut to needed length and connect the 9.5 mm drain line (provided) to the water softener valve drain fitting. Use a hose clamp to hold the hose in place.

**IMPORTANT:** If codes require a rigid drain line see "Valve Drain requirements" section.

2. Run the drain hose (or a rigid line) to the floor drain. Secure drain hose. This will prevent "whipping" during recharges. **Be sure to provide a 4 cm minimum air gap to prevent possible sewer water backup.** See "Air Gap Requirements" section.

**NOTE:** In addition to a floor drain, you can use a laundry tub or standpipe as a good drain point for this hose. Avoid long drain hose runs, or elevating the hose more than 2.5 meters above the floor.

## INSTALL SALT STORAGE TANK OVERFLOW HOSE

1. Measure, cut to needed length and connect the 9.5 mm drain line (provided) to the salt storage tank overflow elbow and secure in place with a hose clamp.
2. Route the hose to the floor drain, or other suitable drain point no higher than the drain fitting on the salt storage tank (This is a gravity drain). If the tank overfills with water, the excess water flows to the drain point. Cut the drain line to the desired length and route it neatly out of the way.

**IMPORTANT:** For proper operation of the water softener, do not connect the water softener valve drain tubing to the salt storage tank overflow hose.

## TEST FOR LEAKS

To prevent air pressure in the water softener and plumbing system, complete the following steps in order:

1. Fully open two or more softened cold water faucets close to the water softener, located downstream from the water softener.
2. Place the bypass valve (single or 3 valve) into the "bypass" position. See Figures 6 & 7 on Page 4.
3. Slowly open the main water supply valve. Run water until there is a steady flow from the opened faucets, with no air bubbles.
4. Place bypass valve(s) in "service" or soft water position as follows:
  - Single bypass valve: Slowly move the valve stem toward "service," pausing several times to allow the water softener to fill with water.
  - 3 valve bypass: Fully close the bypass valve and open the outlet valve. Slowly open the inlet valve, pausing several times to allow the water softener to fill with water.
5. After about three minutes, open a hot water faucet until there is a steady flow and there are no air bubbles, then close this faucet.
6. Close all cold water faucets and check for leaks at the plumbing connections that you made.
7. Check for leaks around clips at softener's inlet and outlet. If a leak occurs at a clip, depressurize the plumbing (turn off the water supply and open faucets) before removing clip. When removing clips at the softener's inlet or outlet, push the single bypass valve body toward the softener (See Figure 15). Improper removal may damage clips. Do not reinstall damaged clips.

# Installation Instructions

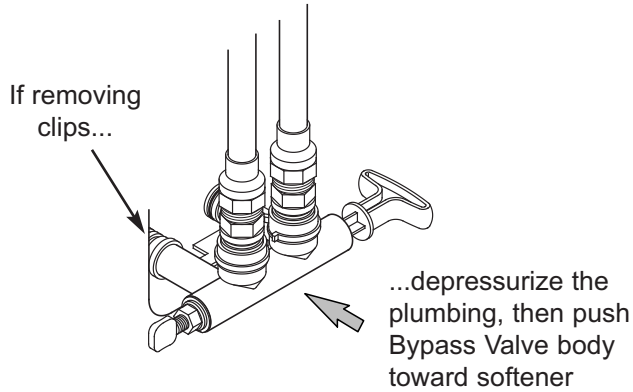

FIG. 15

## ADD WATER AND SALT TO THE SALT STORAGE TANK

1. Using a container, add about three gallons of clean water into the salt storage tank.
2. Add salt to the storage tank. Use salt which indicates it complies with European Standard "EN 973".

## INSTALL AND PLUG IN THE POWER SUPPLY

During installation, the water softener wiring may be moved or jostled from place. Check to be sure all leadwire connectors are secure on the back of the electronic board and be sure all wiring is away from the valve gear and motor area, which rotates during recharges.

1. Remove the power supply from its packaging and snap the appropriate modular plug (Europe or UK) into place.
2. At the other end of the wires are two small connectors. Plug these into the power wire harness coming from the back of the electronic control board (See Schematic on Page 22).
3. Plug the power supply into an electrical outlet that is not controlled by a switch and is approved by local codes. The unit works on 24V DC. Do not connect without the power supply.

## PROGRAM THE CONTROLLER

1. Install the softener's top cover and salt lid.
2. Complete the programming steps on Page 10.

## SANITIZE THE WATER SOFTENER / SANITIZE AFTER SERVICE

Care is taken at the factory to keep your unit clean and sanitary. Materials used to make the unit will not infect or contaminate your water supply, and will not cause bacteria to form or grow. However, during shipping, storage, installation and operation, bacteria could get into the unit. For this reason, sanitizing as follows is suggested\* when installing.

1. Slide open the salt lid, remove the brinewell cover and pour about 90 ml (6 tablespoons) of household bleach into the softener brinewell. Replace the brinewell cover.
2. Make sure the bypass valve(s) is in the "service" (open) position.
- 3 **Start a recharge:** Press the RECHARGE button and hold for 3 seconds, until "Recharge Now" begins to flash in the display. This recharge draws the sanitizing bleach into and through the water softener. Any air remaining in the unit is purged to the drain.
4. After the recharge has completed, fully open a cold water faucet, downstream from the softener, and allow 190 liters of water to pass through the system. This should take at least 20 minutes. Close the faucet.

\*Recommended by the Water Quality Association. On some water supplies, the unit may need periodic disinfecting.

## RESTART THE WATER HEATER

1. Turn on the electricity or fuel supply to the water heater and relight the pilot, if applicable.

**NOTE:** The water heater is filled with hard water and, as hot water is used, it refills with conditioned water. In a few days, the hot water will be fully conditioned. To have fully conditioned hot water immediately, wait until the initial recharge (previous step) is over. Then, drain the water heater (following instructions for water heater) until water runs cold.



# Bypass Blending Valve

The bypass blending valve works as a typical push-pull bypass valve, but has the added ability to finely adjust hardness of the treated water leaving the water softener. If slightly harder water is desired than is normally output by the water softener, this bypass blending valve can divert a small stream of hard water before it enters the water softener and blend it with the exiting softened water. The amount of water diverted is controlled by turning a blend adjusting knob on the end cap of the valve stem (See Figure 16).

1. When the bypass valve is in service position (normal softener operation), with handle pulled all the way out (See Figure 16), **increase hardness** of treated water by turning the blend adjusting knob **counterclockwise** up to 6 turns from the fully closed position. While adjusting this knob, hold the bypass valve handle to prevent the stem from rotating.
2. Do not continue to turn the knob counterclockwise beyond 6 turns from the fully closed position, as this would eventually pull the screw's internal o-rings out of their seat and water would leak from the bypass valve.
3. **Decrease hardness** of treated water by turning the blend adjusting knob **clockwise** while holding the bypass handle. When the knob will not turn any more, hard water is no longer being blended with treated water.
4. Once the desired hardness is achieved, the adjustment knob may be locked in place by tightening the hex nut clockwise against the end cap using an adjustable wrench. Hold the bypass valve handle to prevent the stem from rotating, or else use another wrench to grip the stem on the flats between the end cap and the bypass valve body. Loosen the hex nut (turn it counterclockwise) before readjusting the hardness or closing the diversion path for servicing (see next step)
5. If the water softener is to be serviced or disconnected from the bypass valve, the blend adjusting knob must be turned all the way clockwise to close the diversion path and prevent water leaking from the softener valve inlet of the bypass valve.

## SERVICE POSITION (Normal Softener Operation)

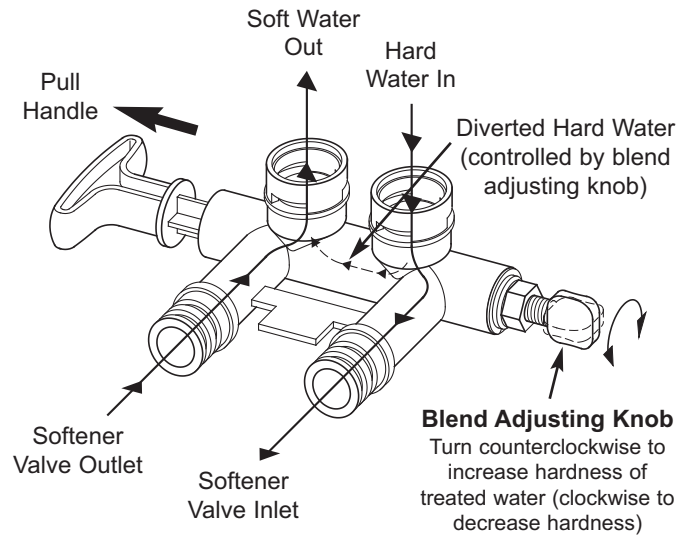

FIG. 16

## BYPASS POSITION

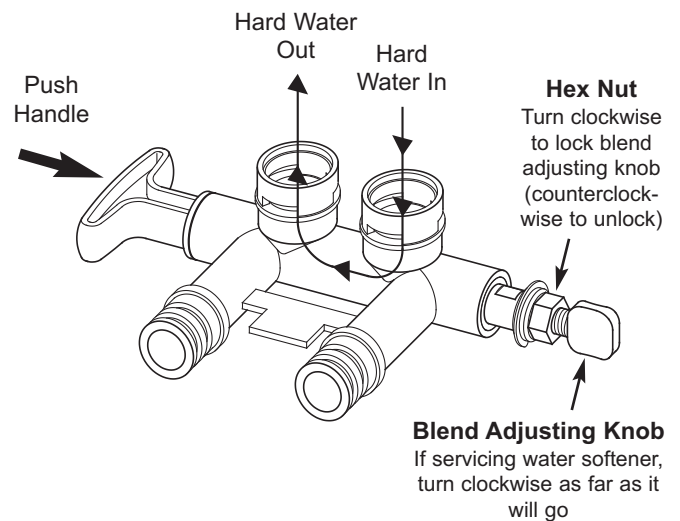

FIG. 17

# Programming the Water Softener

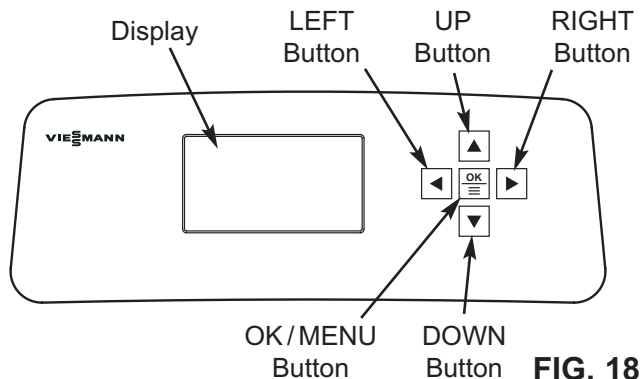

FIG. 18

## SETUP PROCEDURE

When the water softener is plugged in for the first time, a beep sounds and the display briefly shows model information. Next, a series of “wizard” screens prompts you to enter basic operating information:

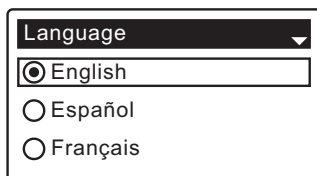

FIG. 19

- 1. LANGUAGE** If the desired language already has a black dot next to it (See Figure 19), go to Step 2. Otherwise, press the softener’s DOWN ▼ or UP ▲ buttons to scroll to the desired language, then press the OK/MENU button to choose it.
- Press the OK/MENU button to advance to the next “wizard” screen.

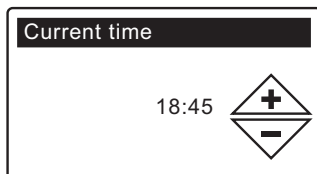

FIG. 20

- 3. CURRENT TIME** Press the DOWN ▼ or UP ▲ buttons to set the current time (See Figure 20). Hold the button down to rapidly advance.
- Press the OK/MENU button.

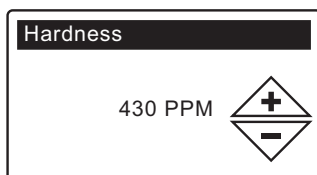

FIG. 21

- 5. HARDNESS** Press the UP ▲ or DOWN ▼ buttons to set the value of your water’s hardness (See Figure 21).

**NOTE:** Do not increase the hardness setting to compensate for iron in your water. The electronic control compensates automatically after you set the iron level in Step 9.

- Press the OK/MENU button.

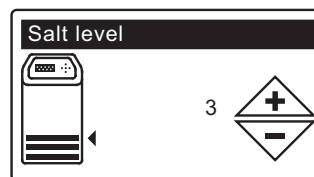

FIG. 22

- 7. SALT LEVEL** Press the UP ▲ or DOWN ▼ buttons to set the salt level (See Figure 22). It should match the lowest number visible on the brinewell above the salt.
- Press the OK/MENU button.

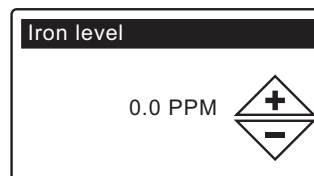

FIG. 23

- 9. IRON LEVEL** Press the UP ▲ or DOWN ▼ buttons to set the value for iron in your water (See Figure 23).
- Press the OK/MENU button. The screen will show “Setup complete!” (See Figure 24).

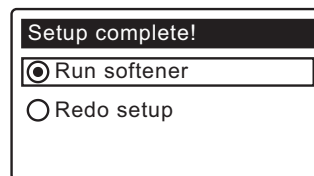

FIG. 24

- If, at this point, you want to go back and make changes, press the DOWN ▼ button to scroll to **Redo setup**, then press the OK/MENU button twice to repeat the “wizard” screens.
- If no changes are desired, make sure **Run softener** has a black dot next to it (See Figure 24) and press the OK/MENU button. The unit begins normal operation, described on the next page.

# Programming the Water Softener

## SOFTENER STATUS SCREENS

During normal operation, the water softener's display shows up to four status screens (Page 16 explains how individual screens can be turned on or off). Each is shown for six seconds, in a rolling sequence (See Figure 25).

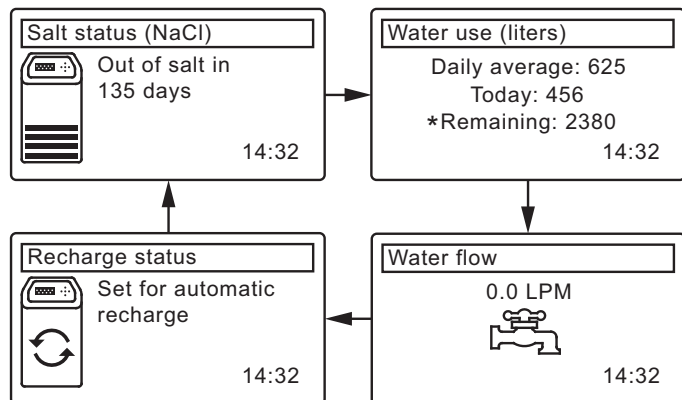

\*Water remaining before the next recharge.

**FIG. 25**

Pressing the softener's RIGHT ► button manually advances to the next screen in the sequence. Pressing the LEFT ◀ button manually returns to the previous status screen. If no buttons are pressed for 30 seconds, the automatic rolling sequence resumes.

## OTHER MESSAGES, ALERTS & REMINDERS

The softener status screens described above will not be displayed in a rolling sequence when one of the following items is displayed:

- **Recharge status** (Displayed during recharges, showing valve position and time remaining)
- **Add salt or Out of salt** (See Page 23)
- **Current time** setting screen instead of status screens indicates time has been lost, perhaps after a long power loss. Set the time (See Page 14).
- **Error detected** (Contact service technician)

## FLASHING BACKLIGHT

The softener's display is backlit to make it easy to read. The backlight will flash on and off when one or more of the following conditions occurs:

- Salt needs to be added
- Time needs to be set (Time has been lost)
- Error condition

The flashing will stop after any key is pressed. However, it will start again at Midnight if the underlying condition (e.g. low salt level) has not been addressed.

# Programming the Water Softener

## MAIN MENU

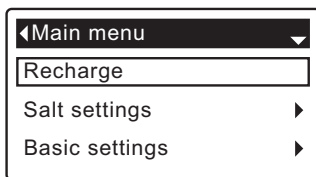

FIG. 26

During normal operation (status screens rolling), press the softener's OK/MENU button to display the Main menu (See Figure 26). This menu and its subsidiary screens are used to control these operations:

- **Recharge** (See Page 14)
- **Salt settings**
  - **Salt level** (See Page 13)
  - **Low salt alarm** (See Page 13)
- **Basic settings**
  - **Current time** (See Page 14)
  - **Hardness** (See Page 15)
  - **Iron level** (See Page 15)
  - **Recharge time** (See Page 15)
  - **Rolling screens** (See Page 16)
- **User preferences**
  - **Language** (See Page 16)
  - **Hardness units** (See Page 17)
- **System information**
  - **Model information** (See Page 18)
  - **Water available** (See Page 18)
  - **Daily avg. water used** (See Page 18)
  - **Water used today** (See Page 18)
  - **Total water used** (See Page 18)
  - **Current water flow** (See Page 18)
  - **Days powered up** (See Page 18)
  - **Last recharge** (See Page 18)
  - **Total recharges** (See Page 18)
- **Advanced settings**
  - **Cycle times**
    - **Backwash time** (See Page 19)
    - **2nd backwash (On/Off)** (See Page 19)
    - **2nd backwash time** (See Page 19)
    - **Fast rinse time** (See Page 19)
  - **Special features**
    - **Efficiency mode** (See Page 20)
    - **Max. days between recharges** (See Page 20)
    - **97% feature** (See Page 20)
  - **Troubleshooting**
    - **Diagnostics** (See Page 21)
    - **Setup changes** (See Page 22)

## LONG DISPLAY SCREEN MESSAGES

Most messages in the softener's display screens are short enough to be shown as a single line. Longer messages will be truncated (See Figure 27 for an example) until you highlight them.

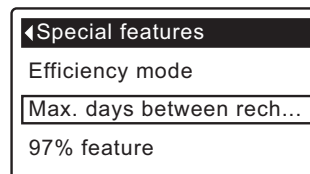

FIG. 27

One second after being highlighted, the viewing box expands (See Figure 28) to show the entire message. After three seconds the view resets (Figure 27).

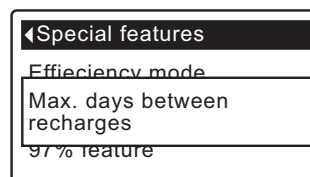

FIG. 28

# Programming the Water Softener

## SETTING SALT LEVEL

Use this feature when adding salt to the softener.

1. From any of the rolling status screens, press the OK/MENU button to display the **Main menu**.
2. Press the DOWN ▼ button to scroll through the menu options until **Salt settings** is highlighted (See Figure 29).

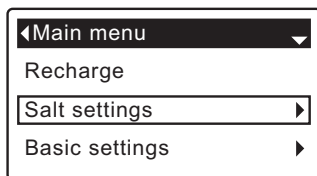

FIG. 29

3. Press the OK/MENU button to display the Salt settings menu (See Figure 30).

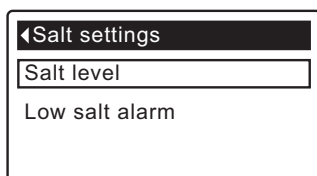

FIG. 30

4. Make sure **Salt level** is highlighted.
5. Press the OK/MENU button to display the Salt level screen (See Figure 31). This screen will not automatically exit for 15 minutes.

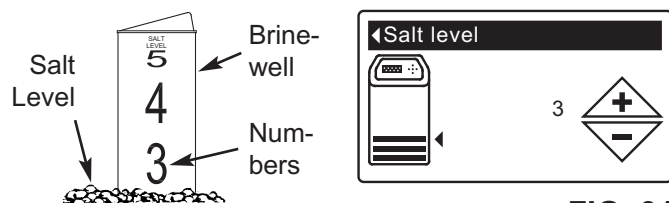

FIG. 31

6. After adding and leveling salt, observe the numbered scale on the brine well (See Figure 31). Press UP ▲ or DOWN ▼ to change the salt level to match the lowest number visible above the salt.
7. Press the OK/MENU button. The display will go back to the Salt settings menu (Figure 30).
8. Press the LEFT ◀ button twice to return to the rolling status screens. It will also exit automatically if no buttons are pressed for four minutes.

## LOW SALT ALARM

Use this feature to program when the electronic control will display a low salt alarm. The number of days can be customized, or the feature can be turned off. The default is 20 days.

- 1-3. Go to the **Salt settings** menu by following Steps 1-3 in "Setting Salt Level" at left.
4. Press the DOWN ▼ button to scroll through the menu options until **Low salt alarm** is highlighted.
5. Press the OK/MENU button to display the Low salt alarm screen (See Figure 32).

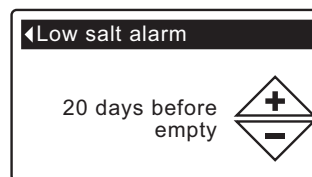

FIG. 32

6. Press the UP ▲ or DOWN ▼ buttons to change the number of days. Set the number of days to provide enough time to purchase salt and avoid running into hard water. Setting the number of days below 1 turns the alarm feature off.
7. Press the OK/MENU button. The display will go back to the Salt settings menu.
8. Press the LEFT ◀ button twice to return to the rolling status screens.

# Programming the Water Softener

## RECHARGING THE SOFTENER

This feature may be used to assure an adequate supply of softened water at times of unusually high water use. For example, if you have guests and the “Water available” screen (See Page 18) is at or below 50%, you could deplete softened water capacity before the next automatic recharge. Initiating a manual recharge will restore 100% softened water capacity after complete.

1. From any of the rolling status screens, press the OK/MENU button to display the **Main menu**.

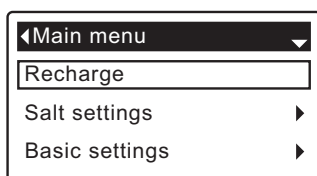

FIG. 33

2. Make sure **Recharge** is highlighted (See Figure 33).
3. Press the OK/MENU button to display the Recharge menu (See Figure 34).

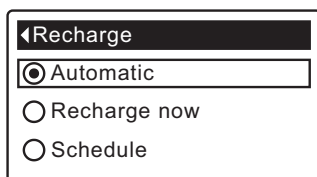

FIG. 34

4. If the desired option already has a black dot next to it (See Figure 34), go to Step 5. Otherwise, press the DOWN ▼ or UP ▲ buttons to scroll to the desired option, then press OK/MENU to choose it.

- **Automatic** cancels a manually scheduled recharge (if it has not already begun) and lets the electronic control determine when to recharge next.

- **Recharge now** begins a recharge immediately after the OK/MENU button is pushed again in Step 5.

- **Schedule** sets a recharge to begin at the preset recharge time (set according to the instructions on Page 15).

5. Press the OK/MENU button. If **Recharge now** is selected, the display immediately goes to the Recharge status screen (See Figure 35). If **Automatic** or **Schedule** are selected, the display goes back to the Main menu (Figure 33).

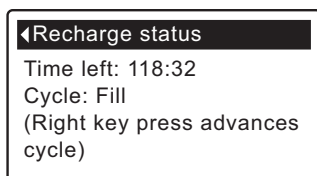

FIG. 35

6. Press the LEFT ◀ button (twice from the Recharge status screen) to return to the rolling status screens.

## SETTING THE CURRENT TIME

When the softener's electronic control is first powered up, a “wizard” screen prompts you to set the current time (See Page 10). To change the time at a later date, such as after a long power loss:

1. From any of the rolling status screens, press the OK/MENU button to display the **Main menu**.
2. Press the DOWN ▼ button to scroll through the menu options until **Basic settings** is highlighted (See Figure 36).

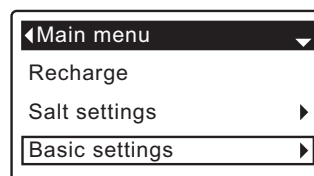

FIG. 36

3. Press the OK/MENU button to display the Basic settings menu (See Figure 37).

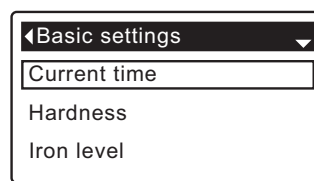

FIG. 37

4. Make sure **Current time** is highlighted.
5. Press the OK/MENU button to display the Current time screen (See Figure 38).

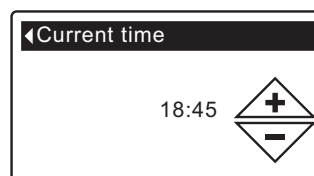

FIG. 38

6. Press the UP ▲ or DOWN ▼ buttons to change the time. Hold the button down to rapidly advance. Be sure that AM or PM is correct (unless softener is set for a 24-hour clock).
7. Press the OK/MENU button. The display will go back to the Basic settings menu (Figure 37).
8. Press the LEFT ◀ button twice to return to the rolling status screens.

# Programming the Water Softener

## SETTING RECHARGE TIME

When the softener's electronic control is first powered up, the default time for starting an automatic recharge is 02:00. This is a good time in most households because water is not being used. To change this time:

1. From any of the rolling status screens, press the OK/MENU button to display the **Main menu**.
2. Press the DOWN ▼ button to scroll through the menu options until **Basic settings** is highlighted (See Figure 39).

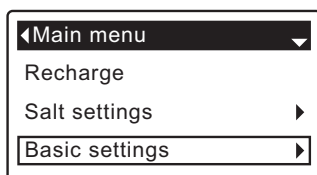

FIG. 39

3. Press the OK/MENU button to display the Basic settings menu (See Figure 40).

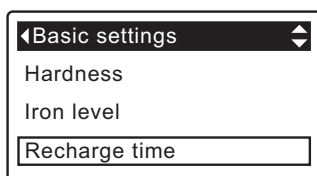

FIG. 40

4. Press the DOWN ▼ button to scroll through the menu options until **Recharge time** is highlighted.
5. Press the OK/MENU button to display the Recharge time screen (See Figure 41).

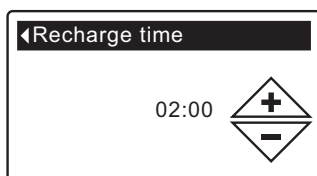

FIG. 41

6. Press the UP ▲ or DOWN ▼ buttons to change the recharge time in 1 hour increments. Hold the button down to rapidly advance. Be sure that AM or PM is correct (unless softener is set for a 24-hour clock).
7. Press the OK/MENU button. The display will go back to the Basic settings menu (Figure 40).
8. Press the LEFT ◀ button twice to return to the rolling status screens.

## SETTING HARDNESS

When the softener's electronic control is first powered up, a "wizard" screen prompts you to enter your water's hardness (See Page 10). To change it:

- 1-3. Go to the **Basic settings** menu by following Steps 1-3 in "Setting Recharge Time" at left.
4. Press the DOWN ▼ button to scroll through the menu options until **Hardness** is highlighted.
5. Press the OK/MENU button to display the Hardness screen (See Figure 42).

1 grain = 1°dH  
10 ppm = 1°f

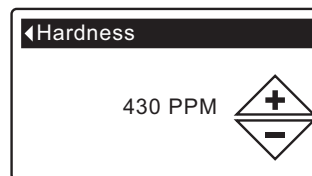

FIG. 42

6. Press the UP ▲ or DOWN ▼ buttons to set the value for your water's hardness. Hold the button down to rapidly advance.

**NOTE:** Do not increase the hardness setting to compensate for iron in your water. The electronic control compensates automatically after you set the iron level, below.

7. Press the OK/MENU button. The display will go back to the Basic settings menu.
8. Press the LEFT ◀ button twice to return to the rolling status screens.

## SETTING IRON LEVEL

When the softener's electronic control is first powered up, a "wizard" screen prompts you to enter your water's iron level (See Page 10). To change:

- 1-3. Go to the **Basic settings** menu by following Steps 1-3 in "Setting Recharge Time" at left.
4. Press the DOWN ▼ button to scroll through the menu options until **Iron level** is highlighted.
5. Press the OK/MENU button to display the Iron level screen (See Figure 43).

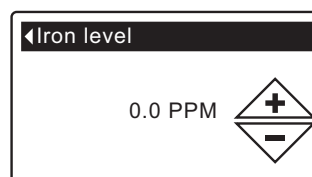

FIG. 43

6. Press the UP ▲ or DOWN ▼ buttons to set the value for iron in your water. Hold the button down to rapidly advance.
7. Press the OK/MENU button. The display will go back to the Basic settings menu.
8. Press the LEFT ◀ button twice to return to the rolling status screens.

# Programming the Water Softener

## MODIFYING ROLLING SCREENS

During normal softener operation, four status screens are shown in sequence (See “Softener Status Screens” on Page 11). When the softener’s electronic control is first powered up, the default is to show all four. You can turn on/off individual screens\*:

1. From any of the rolling status screens, press the OK/MENU button to display the **Main menu**.
2. Press the DOWN ▼ button to scroll through the menu options until **Basic settings** is highlighted (See Figure 44).

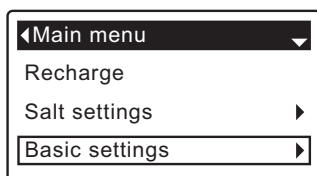

FIG. 44

3. Press the OK/MENU button to display the Basic settings menu (See Figure 45).

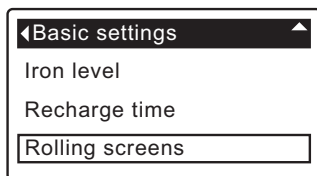

FIG. 45

4. Press the DOWN ▼ button to scroll through the menu options until **Rolling screens** is highlighted.
5. Press the OK/MENU button to display the Rolling screens menu (See Figure 46).

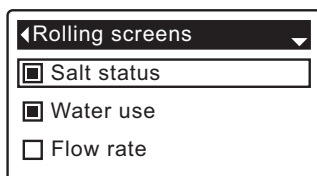

FIG. 46

6. Press the DOWN ▼ or UP ▲ buttons to scroll through the list. Items with a black square next to them will be displayed during normal operation.
7. To un-select a screen, make sure its name is highlighted in a box. Then press the OK/MENU button. The black square will disappear. Pressing OK/MENU again makes the black square reappear and re-selects the highlighted item. At least one screen must be selected/highlighted.
8. When selections are complete, exit this menu by pressing the LEFT ◀ button. The display will go back to the Basic settings menu (Figure 45).
9. Press the LEFT ◀ button twice to return to the rolling status screens.

\*This does not include, errors, alerts or Recharge status screens.

## SETTING THE LANGUAGE

When the softener’s electronic control is first powered up, a “wizard” screen prompts you to set the language (See Page 10). To change the language:

1. From any of the rolling status screens, press the OK/MENU button to display the **Main menu**.
2. Press the DOWN ▼ button to scroll through the menu options until **User preferences** is highlighted (See Figure 47).

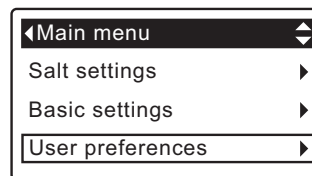

FIG. 47

3. Press the OK/MENU button to display the User preferences menu (See Figure 48).

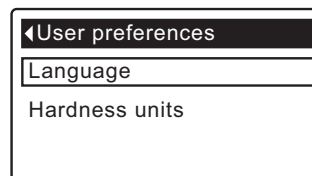

FIG. 48

4. Make sure **Language** is highlighted.
5. Press the OK/MENU button to display the Language menu (See Figure 49).

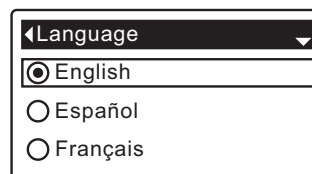

FIG. 49

6. If the desired language already has a black dot next to it (See Figure 49), go to Step 7. Otherwise, press the DOWN ▼ or UP ▲ buttons to scroll to the desired language, then press OK/MENU to choose it. The choices are: English, Spanish, French, Italian, German, Dutch, Turkish or Greek.
7. Press the OK/MENU button. The display will go back to the User preferences menu (Figure 48).
8. Press the LEFT ◀ button twice to return to the rolling status screens.

### TO RESET TO YOUR NATIVE LANGUAGE IF ANOTHER LANGUAGE IS DISPLAYED:

From the rolling status screens, press OK/MENU. Press DOWN ▼ three times, then press OK/MENU twice. Press DOWN ▼ or UP ▲ to scroll to your native language, then press OK/MENU twice. Press LEFT ◀ twice to exit all menus.



---

# Programming the Water Softener

## SETTING HARDNESS UNITS

Use this feature to select grains or parts per million (ppm) as hardness units.

1. From any of the rolling status screens, press the OK/MENU button to display the **Main menu**.
2. Press the DOWN ▼ button to scroll through the menu options until **User preferences** is highlighted (See Figure 50).

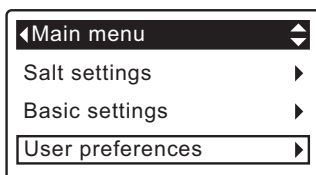

FIG. 50

3. Press the OK/MENU button to display the User preferences menu (See Figure 51).

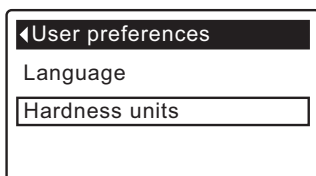

FIG. 51

4. Press the DOWN ▼ button to scroll through the menu options until **Hardness units** is highlighted.
5. Press the OK/MENU button to display the Hardness units menu (See Figure 52).

1 grain = 1°dH  
10 ppm = 1°f

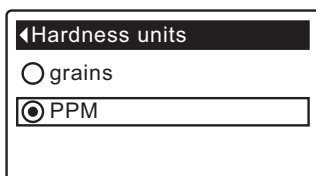

FIG. 52

6. If the desired hardness unit already has a black dot next to it (See Figure 52), go to Step 7. Otherwise, press the DOWN ▼ or UP ▲ buttons to scroll to the other hardness unit, then press OK/MENU to choose it.
7. Press the OK/MENU button. The display will go back to the User preferences menu.
8. Press the LEFT ◀ button twice to return to the rolling status screens.

# Programming the Water Softener

## SYSTEM INFORMATION

Use these features to look up the following information about the softener and its operations:

- **Model information** (model number and software version)
- **Water available** (softened water ready for use)
- **Daily average water used**
- **Water used today**
- **Total water used** (explained in Step 6, below)
- **Current water flow**
- **Days powered up**
- **Last recharge**
- **Total recharges**

To display one of these screens:

1. From any of the rolling status screens, press the OK/MENU button to display the **Main menu**.
2. Press the DOWN ▼ button to scroll through the menu options until **System information** is highlighted (See Figure 53).

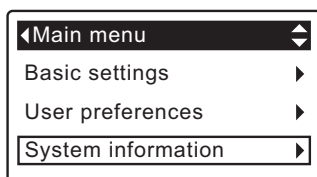

FIG. 53

3. Press the OK/MENU button to display the System information menu (See Figure 54).

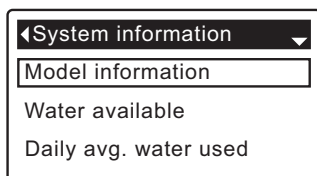

FIG. 54

4. Press the DOWN ▼ button to scroll through the menu options until the desired option is highlighted (See list at the top of this column).
5. Press the OK/MENU button to display the desired information screen (See Figures 55-63).
6. The **Total water used** screen (See Figure 59) shows the volume of water used since it was last reset (it works like the trip odometer in a car). To reset the value to 0, press the RIGHT ► button while this screen is displayed.
7. When finished viewing an information screen, press the OK/MENU button. The display will go back to the System information menu (Figure 54). It will also exit automatically if no buttons are pressed for four minutes.
8. Press the LEFT ◀ button twice to return to the rolling status screens.

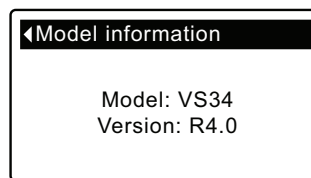

FIG. 55



FIG. 56



FIG. 57

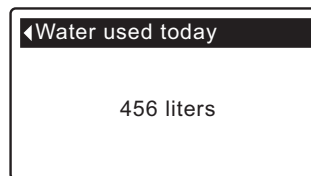

FIG. 58

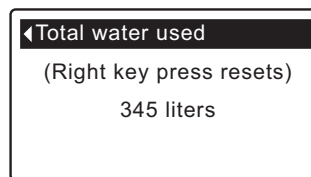

FIG. 59

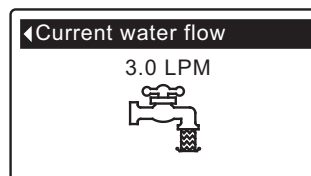

FIG. 60

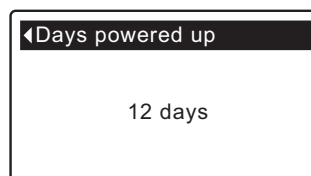

FIG. 61

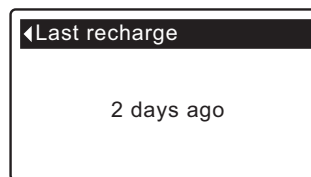

FIG. 62

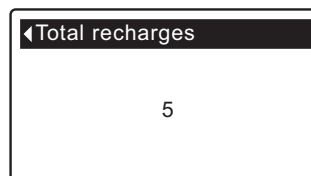

FIG. 63

# Programming the Water Softener

## CYCLE TIMES

Use these features to change the following softener operations:

- Backwash time
- Second backwash (On/Off)
- Second backwash time
- Fast rinse time

To display these screens:

1. From any of the rolling status screens, press the OK/MENU button to display the **Main menu**.
2. Press the DOWN ▼ button to scroll through the menu options until **Advanced settings** is highlighted (See Figure 64).

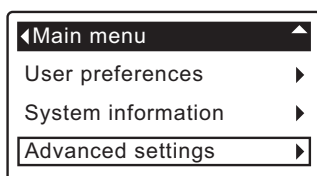

FIG. 64

3. Press the OK/MENU button to display the Advanced settings menu (See Figure 65).

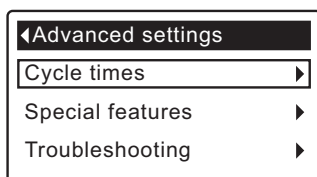

FIG. 65

4. Make sure **Cycle times** is highlighted.
5. Press the OK/MENU button to display the Cycle times menu (See Figure 66).

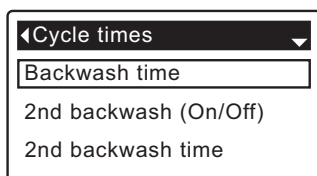

FIG. 66

6. Press the DOWN ▼ button to scroll through the menu options until the desired option is highlighted (See list at the top of this column).
7. Press the OK/MENU button to display the desired information screen (See Figures 67-70).
8. See the right column on this page for specific instructions on each cycle time screen.

9. Press the OK/MENU button. The display will go back to the Cycle times menu (Figure 66).
10. Press the LEFT ◀ button three times to return to the rolling status screens.

- 8a. **Backwash time:** Press the UP ▲ or DOWN ▼ buttons to change the backwash time. Hold the button down to rapidly advance. The backwash time can be set as high as 30 minutes\* (See Figure 67).



FIG. 67

- 8b. **Second backwash (On/Off):** If the desired option already has a black dot next to it (See Figure 68), go to Step 9. Otherwise, press the DOWN ▼ or UP ▲ buttons to scroll to the other option, then press OK/MENU to choose it. Setting this feature On adds a second backwash and rinse at the beginning of the recharge cycle. Default is Off. Set this feature On if your water supply contains a lot of sediment or iron.

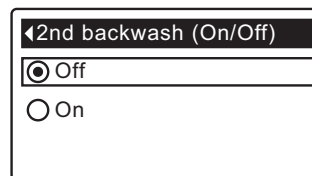

FIG. 68

- 8c. **Second backwash time:** Press the UP ▲ or DOWN ▼ buttons to change the second backwash time. Hold the button down to rapidly advance. The time can be set as high as 30 minutes (See Figure 69).

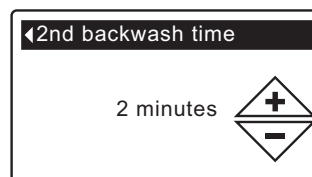

FIG. 69

- 8d. **Fast rinse time:** Press the UP ▲ or DOWN ▼ buttons to change the fast rinse time. Hold the button down to rapidly advance. The fast rinse time can be set as high as 30 minutes\* (See Figure 70).



FIG. 70

\*Reducing the backwash and fast rinse times below a softener model's default settings can result in salty water after recharges.

# Programming the Water Softener

## SPECIAL FEATURES

Use these features to change the following operations:

- **Efficiency mode**
- **Maximum days between recharges**
- **97% feature**

To display one these screens:

1. From any of the rolling status screens, press the OK/MENU button to display the **Main menu**.
2. Press the DOWN ▼ button to scroll through the menu options until **Advanced settings** is highlighted (See Figure 71).

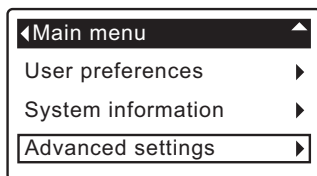

FIG. 71

3. Press the OK/MENU button to display the Advanced settings menu (See Figure 72).

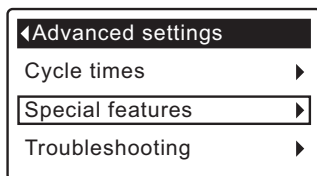

FIG. 72

4. Press the DOWN ▼ button to scroll through the menu options until **Special features** is highlighted.
5. Press the OK/MENU button to display the Special features menu (See Figure 73).

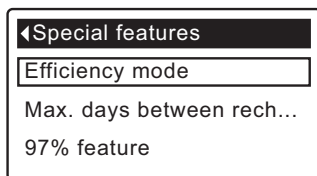

FIG. 73

6. Press the DOWN ▼ button to scroll through the menu options until the desired option is highlighted (See list at the top of this column).
7. Press the OK/MENU button to display the desired information screen (See Figures 74-76).
8. **See the right column on this page for specific instructions on each cycle time screen.**
9. Press the OK/MENU button. The display will go back to the Special features menu (Figure 73).
10. Press the LEFT ◀ button three times to return to the rolling status screens.

- 8a. **Efficiency mode:** If the desired efficiency mode already has a black dot next to it (See Figure 74), go to Step 9. Otherwise, press the DOWN ▼ or UP ▲ buttons to scroll to the desired efficiency mode, then press OK/MENU to choose it.

- **Salt efficient** limits available salt doses to maintain 4 mol/kg of salt efficiency. Units may recharge more frequently.

- **Auto adjusting** is the default. It automatically adjusts salt doses to target a 3-4 day interval between recharges. Recommended.

- **High capacity** is for applications where very low “bleed” (less than 1.5 ppm) of hardness can be tolerated. Such applications include water for boilers. This setting will consume higher quantities of salt.

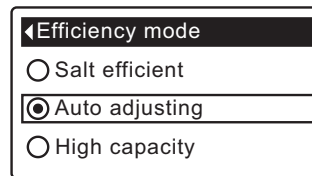

FIG. 74

- 8b. **Maximum days between recharges:** Press the UP ▲ or DOWN ▼ buttons to change the number of days (See Figure 75). The feature can be set from 1 to 15 days. Setting the number of days below 1 turns the feature off and defaults to automatic control of recharging. Default is Auto.

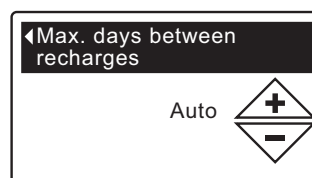

FIG. 75

- 8c. **97% feature:** If the desired option already has a black dot next to it (See Figure 76), go to Step 9. Otherwise, press the DOWN ▼ or UP ▲ buttons to scroll to the other option, then press OK/MENU to choose it. If this feature is On, the softener will automatically recharge when 97% of capacity is used, at any time of day. Default is Off.

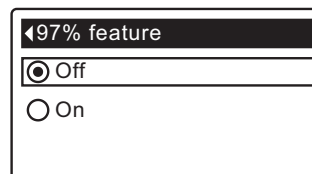

FIG. 76

# Programming the Water Softener

## DIAGNOSTICS

This feature allows a service technician to check the operating state of individual components in the softener (e.g. valve position) to troubleshoot problems. **If an error code is displayed in place of the rolling status screens, contact a service technician.**

To view the Diagnostics screen:

1. If an error code is displayed, skip Steps 2-7 and go directly to Step 8.
2. To display the Diagnostics screen from any of the rolling status screens (when an error code is not displayed), press the OK/MENU button to display the **Main menu**.
3. Press the DOWN ▼ button to scroll through the menu options until **Advanced settings** is highlighted (See Figure 77).

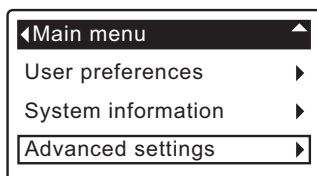

FIG. 77

4. Press the OK/MENU button to display the Advanced settings menu (See Figure 78).

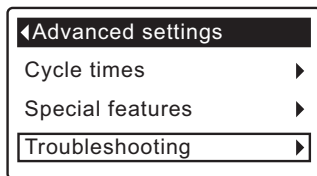

FIG. 78

5. Press the DOWN ▼ button to scroll through the menu options until **Troubleshooting** is highlighted.
6. Press the OK/MENU button to display the Troubleshooting menu (See Figure 79).

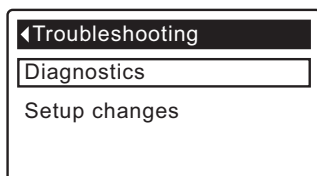

FIG. 79

7. Make sure **Diagnostics** is highlighted.
8. Press the OK/MENU button to display the Diagnostics screen (See Figure 80).

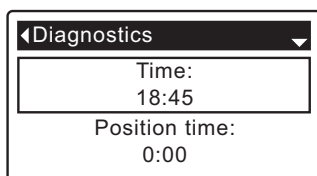

FIG. 80

9. Press the DOWN ▼ or UP ▲ buttons to scroll through the list. The following items are displayed:
  - **Time** (current)
  - **Position time** (counts down the time remaining in the current valve position)
  - **Current position** (of the valve: service, fill, brine, backwash, fast rinse or moving)
  - **Requested position** (of the valve)
  - **Motor state** (on or off)
  - **Valve position switch** (open or closed)
  - **Turbine count** (if changing, indicates water flow)
  - **Tank light switch** (open or closed)
  - **Error code** (call for service if a number is displayed)
10. When finished viewing the Diagnostics screen, press the OK/MENU button. The display will go back to the Troubleshooting menu (Figure 79).
11. Press the LEFT ◀ button three times to return to the rolling status screens (or error code screen if an error condition exists).

# Programming the Water Softener

## SETUP CHANGES

This feature allows a service technician to repeat the setup procedure (See Page 10) or restore the softener's default operating values.

1. From any of the rolling status screens, press the OK/MENU button to display the **Main menu**.
2. Press the DOWN ▼ button to scroll through the menu options until **Advanced settings** is highlighted.
3. Press the OK/MENU button to display the Advanced settings menu.
4. Press the DOWN ▼ button to scroll through the menu options until **Troubleshooting** is highlighted.
5. Press the OK/MENU button to display the Troubleshooting menu.
6. Press the DOWN ▼ button to scroll through the menu options until **Setup changes** is highlighted.
7. Press the OK/MENU button to display the Setup changes menu (See Figure 81).

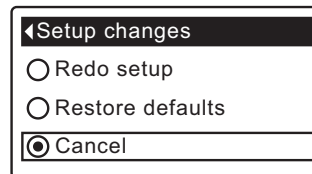

FIG. 81

8. If the desired option already has a black dot next to it (See Figure 81), go to Step 9. Otherwise, press the DOWN ▼ or UP ▲ buttons to scroll to the desired option, then press OK/MENU to choose it.
  - **Redo setup** allows you to select a different model code (intended to be used for upgrades or retrofits of existing softener). Model codes are listed on Page 2.
  - **Restore defaults** will reset all customizable settings to their default values and take you through the "wizard" screen setup procedure (See Page 10).
  - **Cancel** will return to the Troubleshooting menu.
9. Press the OK/MENU button.

## AUXILIARY OUTPUT

The electronic controller's auxiliary output is used to operate a chlorine generator. It provides a 24V DC, up to 500 mA, current from terminal J8 on the electronic

control board (see schematic below). This current is on during the brine draw portion of the softener's regeneration cycle.

## WIRING SCHEMATIC

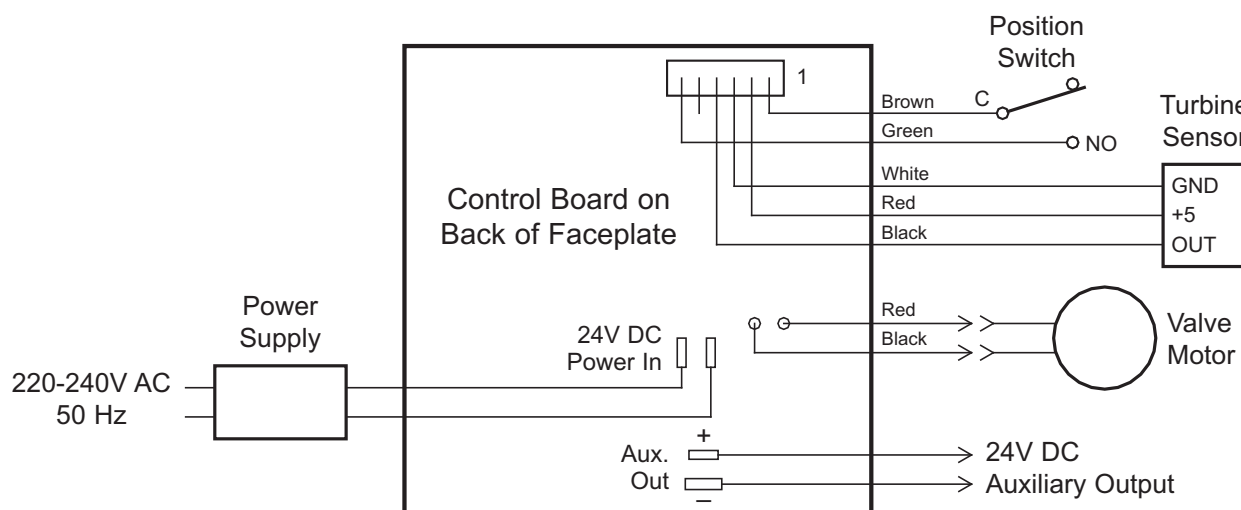

FIG. 82

# Routine Maintenance

## REFILLING WITH SALT

If the softener uses all the salt before more is added, hard water will result. Lift the brine tank lid and check the salt level frequently. The softener can also be programmed to display a Low Salt Alarm a certain number of days before salt is estimated to run out (See Page 13).

Be sure that the brinewell cover is on when adding salt. After adding and leveling salt, always set the salt level on the electronic controller, as described on Page 13.

**NOTE:** In humid areas it is best to keep the salt level less than half full and refill more often.

**RECOMMENDED SALT:** Use salt which indicates it complies with European Standard "EN 973".

**SALT NOT RECOMMENDED:** Rock salt high in impurities, block, granulated, table, ice melting, or ice cream making salts, etc., are not recommended.

**SALT WITH IRON REMOVING ADDITIVE:** Some salts have an additive to help a water softener handle iron in the water supply. Although this may help keep the resin bed clean, it may also release corrosive fumes that will weaken and shorten the life of some water softener electronic parts.

## BREAKING A SALT BRIDGE

Sometimes a hard crust or salt "bridge" forms in the brine tank. This is usually caused by high humidity or the wrong kind of salt. When the salt bridges, an empty space forms between the water and the salt. Then salt will not dissolve in the water to make brine. Without brine, the resin bed is not recharged and hard water will result.

If the storage tank is full of salt, it is difficult to tell whether there is a salt bridge. A bridge may be underneath loose salt. The following is the best way to check for a salt bridge:

Salt should be loose all the way to the bottom of the tank. Hold a broom handle, or like tool, up to the softener, as shown in Figure 83. Make a pencil mark on the handle 3 - 5 cm below the top of the rim. Then, carefully push it straight down into the salt. If a hard object is felt before the pencil mark is even with the top, it is most likely a salt bridge. Carefully push into the bridge in several places to break it. **Do not try to break the salt bridge by pounding on the outside of the salt tank. You may damage the tank.**

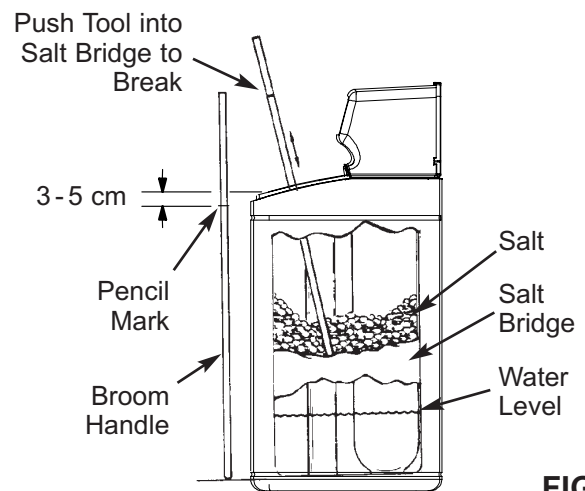

FIG. 83

# Routine Maintenance

## CLEANING THE NOZZLE & VENTURI

A clean nozzle & venturi (See Figure 84) is necessary for the water softener to work properly. This small unit creates the suction to move brine from the brine tank into the resin tank. If it should become plugged with dirt, silt, sand, etc., the softener will not work and hard water will result.

To get access to the nozzle & venturi, remove the softener's top cover. Put the bypass valve(s) into the bypass position. Be sure the softener is in the service cycle (no water pressure at the nozzle & venturi). Then, holding the nozzle & venturi housing with one hand, turn the cap to remove it. Do not lose the o-ring seal. Lift out the screen support and screen. Then, remove the nozzle & venturi. Wash the parts in warm, soapy water and rinse in fresh water. If needed, use a small brush to remove iron or dirt. Be careful not to scratch, misshape, etc., surfaces of the nozzle & venturi. Also, check and clean the gasket and flow plug(s) if dirty.

Carefully replace all parts in the correct order. Lubricate the o-ring seal with silicone grease and put in place. Install and tighten the cap, by hand only. Do not overtighten, which could break the cap or housing. Put the bypass valve(s) into service (softened water) position.

## RESIN BED CLEANING

If the water supply contains clear water iron, regular resin bed cleaning is needed to keep the bed from coating with iron. Use resin bed cleaner, following directions on the container. Clean the resin every six months, or more often if iron appears in the softened water supply.

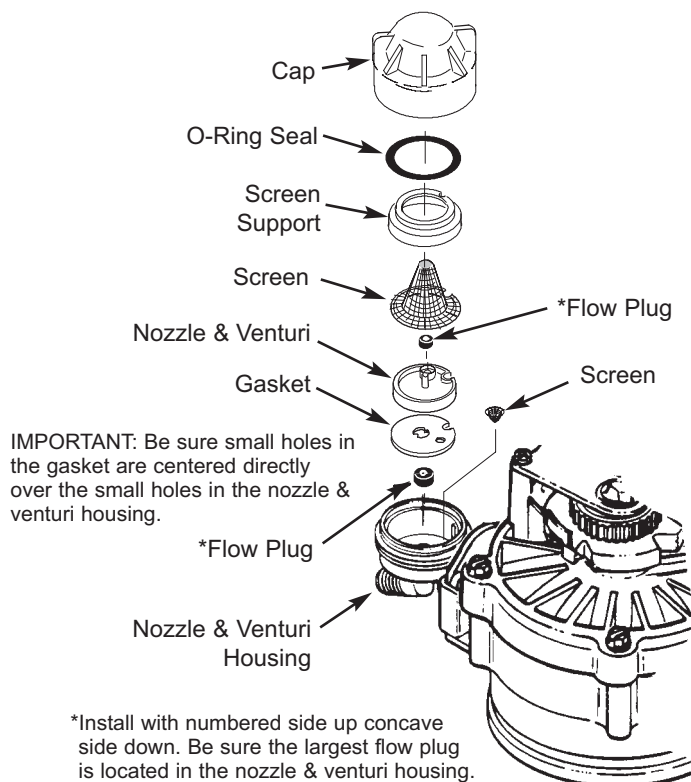

FIG. 84



# Troubleshooting Guide

PROBLEM	CAUSE	CORRECTION
<b>No soft water</b>	No salt in the storage tank.	Add salt (See Page 23) and then initiate a "Recharge now," as shown on Page 14.
	Salt is "bridged."	Break salt bridge (See Page 23) and then initiate a "Recharge now," as shown on Page 14.
	If display is blank, power supply may be unplugged at wall outlet, power cable leads may be disconnected from the electronic control board, fuse may be blown, circuit breaker may be popped, or power supply may be plugged into a switched outlet which is "off."	Check for power loss due to any of these and correct. When power is restored, if the display shows the "Current Time" setting screen (Figure 38 on Page 14), it means time was lost during the outage. Set the current time. Other settings such as hardness are retained in memory during a power loss.
	Bypass valve(s) in bypass position.	Place bypass valve(s) in service position.
	Dirty, plugged or damaged nozzle & venturi.	Take apart, clean and inspect the nozzle & venturi assembly, as shown on Page 24.
	Valve drain hose plugged or restricted.	Drain hose must not have any kinks, sharp bends, or be raised too high above the softener.
<b>Water hard sometimes</b>	Bypassed hard water being used during recharge, due to current time or recharge time settings being incorrect.	Check the current time displayed. If not correct, refer to "Set Current Time" on Page 14. Check the recharge time, as described on Page 15.
	Hardness number setting is too low.	Referring to "Setting Hardness" on Page 15, check the current hardness setting and increase if needed.
	Hot water being used when softener is recharging.	Avoid using hot water during recharges, because water heater refills with hard water.
	Increase in actual hardness of water supply.	Have unsoftened water sample tested. Referring to Page 15, check the current hardness setting and increase if needed.
	Turbine is not turning freely.	Check turbine, as described on Page 26.
<b>Motor stalled or clicking</b>	Motor malfunction or internal valve fault causing high torque on motor.	Contact a service technician.
<b>Error code E1, E3 or E4 displayed.</b>	Fault in wiring harness, connections to position switch, switch, valve or motor.	Contact a service technician.
<b>Error code E5 displayed.</b>	Electronic control malfunction.	Contact a service technician.

## TROUBLESHOOTING - INITIAL CHECKS

### Always make these initial checks first:

1. Is display blank? Check power source.
2. Is Error code displayed? If so, go to "Automatic Electronic Diagnostics" on the next page.
3. Is correct time displayed? If not, recharges occur at the wrong time. Set current time (See Page 14.)
4. Is there salt in the brine tank? If not, refill.
5. Is salt "bridged" (See Page 23)?
6. Are plumbing bypass valve(s) in service position?
7. Are inlet and outlet pipes connected to the water softener inlet and outlet respectively?
8. Is valve drain hose free of kinks and sharp bends, and not elevated over 2 meters above the floor.
9. Is the brine tube connected?
10. Check the hardness setting (See "Setting Hardness" on Page 15). Be sure it is correct for the household's water supply. Perform a hardness test on a raw water sample to compare with the setting.
11. Perform a hardness test on a softened water sample to determine whether a problem exists.

If no problem is found after making the initial checks, proceed to "Troubleshooting - Manual Diagnostics" and "Manual Advance Recharge Check" on the next two pages.

# Troubleshooting

## AUTOMATIC ELECTRONIC DIAGNOSTICS

This softener has a self-diagnostic function for the electrical system (except for input power and/or water meter). The controller monitors electronic components and circuits for correct operation. If a malfunction occurs, an **Error code** is displayed (See Figure 85).

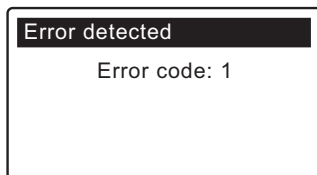

FIG. 85

The troubleshooting chart on the previous page shows the error codes that could appear, and the possible malfunctions for these codes.

When an error code appears in the display, pressing OK/MENU will display the **Diagnostics** screen (See Page 21), so a service technician can further isolate the problem.

## REMOVING ERROR CODE

1. Unplug power supply from electrical outlet.
2. Correct problem.
3. Plug in power supply.
4. Wait for eight minutes while controller operates valve through an entire cycle. The error code will return if the problem was not corrected.

## TROUBLESHOOTING - MANUAL DIAGNOSTICS

1. Display the **Diagnostics** screen, following the procedure on Page 21.
2. Press the DOWN ▼ or UP ▲ buttons to scroll through the list. The following items are displayed:
  - **Time** (current)
  - **Position time** (counts down the time remaining in the current valve position)
  - **Current position** (of the valve: service, fill, brine, backwash, fast rinse or moving) See "Manual Advance Recharge Check" on next page for position verification.
  - **Requested position** (of the valve)
  - **Motor state** (on or off)
  - **Valve position switch** (open or closed)
  - **Turbine count** (indicates water flow) See following section for turbine diagnostics.
  - **Tank light switch** (open or closed)
  - **Error code**

## CHECKING THE TURBINE

1. Display the **Diagnostics** screen, following the procedure on Page 21.
2. Press the DOWN ▼ button to scroll through the list until **Turbine Count** is displayed (See Figure 86).

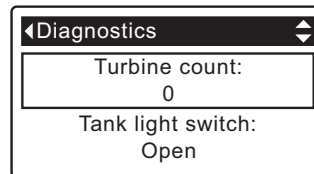

FIG. 86

3. A steady display of "0" (zero) indicates no water flow through the meter (i.e. no softened water being used).
4. Open a nearby softened water faucet.
5. The number in the display should count upward from 0 to 199 for each gallon of flow. 1 gallon = 3.78 liters.
6. If the display reading does not change with the faucet open, pull the wire harness from the valve outlet port (See Figure 87).

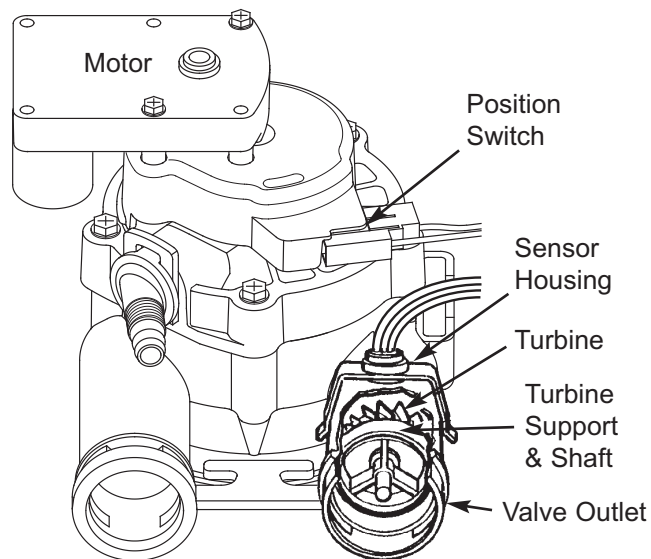

FIG. 87

7. Pass a small magnet back and forth in front of the sensor.
  - 8a. If the displayed **Turbine Count** does count upward with each pass of the magnet, disconnect the outlet plumbing and check the turbine for binding.
  - 8b. If the displayed **Turbine Count** does not count upward with each pass of the magnet, the sensor is probably faulty.

# Troubleshooting

## TROUBLESHOOTING - MANUAL ADVANCE RECHARGE CHECK

This check verifies proper operation of the position switch, gear motor, brine tank fill, brine draw, recharge flow rates, and other controller functions. Always make the Initial Checks (See Page 25) and the Manual Diagnostics (See Page 26) first.

1. Display the **Diagnostics** screen, following the procedure on Page 21.
2. Press the DOWN ▼ button to scroll through the list until **Valve position switch** is displayed (See Figure 88).

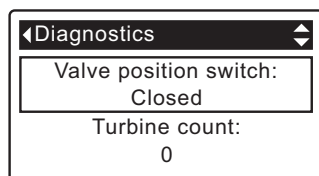

FIG. 88

3. Verify that when the switch plunger is down (into one of the detents on the valve motor cam), this screen reads **Open**. When the valve cam is rotating (for example, after Step 8, below), the switch plunger will be up and this screen should read **Closed**.
4. Press the UP ▲ button to scroll through the list until **Current position** is displayed (See Figure 89).

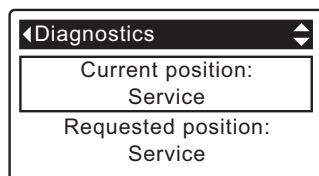

FIG. 89

6. Verify that the valve position indicator on the motor cam agrees with the position displayed on the screen
7. Remove the brinewell cover.
8. With the Diagnostics screen displayed, press the RIGHT ► button once to advance the valve from **Service** to **Fill**.
9. Shine a flashlight into the brinewell and observe fill water entering the tank.
10. If water does not enter the tank, look for an obstructed nozzle / venturi, fill flow plug or brine tube (See Figure 84 on Page 24).
11. After verifying fill, press the RIGHT ► button once to move the valve into **Brine\***. A slow flow of water to the drain will begin. Verify brine draw from the brine tank by shining the flashlight into the brinewell to observe a noticeable drop in the liquid level.

\* If the 2nd Backwash option is set (See Page 19), the valve will enter backwash and fast rinse before brine.

12. If the unit does not draw brine, check for:
  - Dirty or defective nozzle / venturi (See Page 24)
  - Nozzle / venturi not seated on the gasket or gasket not sealing properly
  - Restriction in valve drain, causing back pressure (bends, kinks, elevated too high, etc.)
  - Obstruction in valve or brine tubing
  - Internal valve fault (obstructed outlet disc, wave washer faulty etc.)
13. With the Diagnostics screen displayed, once again press the RIGHT ► button to advance the valve to **Backwash**.
14. Look for a fast flow of water from the drain hose. If flow is slow, check for a plugged top distributor, backwash flow plug or drain hose
15. With the Diagnostics screen displayed, once again press the RIGHT ► button to advance the valve to **Fast rinse**.
16. Again, look for a fast flow of water from the drain hose. Allow the unit to rinse for several minutes to flush out any brine that may remain from the brine cycle test.
17. With the Diagnostics screen displayed, once again press the RIGHT ► button to return the valve to the **Service** position.

**IMPORTANT:** Always return the valve to the **Service** position before exiting this procedure.

## OTHER SERVICE

**Hard Water Bypass** (Hard water “bleeds” into softened water supply):

1. Faulty inlet disc, seal or wave washer (See Pages 30 & 31).
2. Missing or faulty o-ring(s) at valve connection to riser pipe.

**Water Leaks from Drain Hose** during service:

1. Faulty inlet disc, seal or wave washer.
2. Faulty o-ring on inlet disc shaft.
3. Faulty outlet disc, seal or wave washer.

**Flooded Salt Tank:**

1. Nozzle / venturi plugged.
2. Faulty valve seals.
3. Restricted or plugged backwash / fast rinse controls.
4. Restricted or plugged drain line.

**Water Has Salty Taste:**

1. House water pressure low. Adjust well pump.
2. Partially restricted valve drain hose, top distributor, backwash flow plug, resin tank internal riser pipe, or bottom distributor.
3. Backwash and fast rinse times have been reduced from default settings.
4. Wrong model code.

# Softener Exploded View

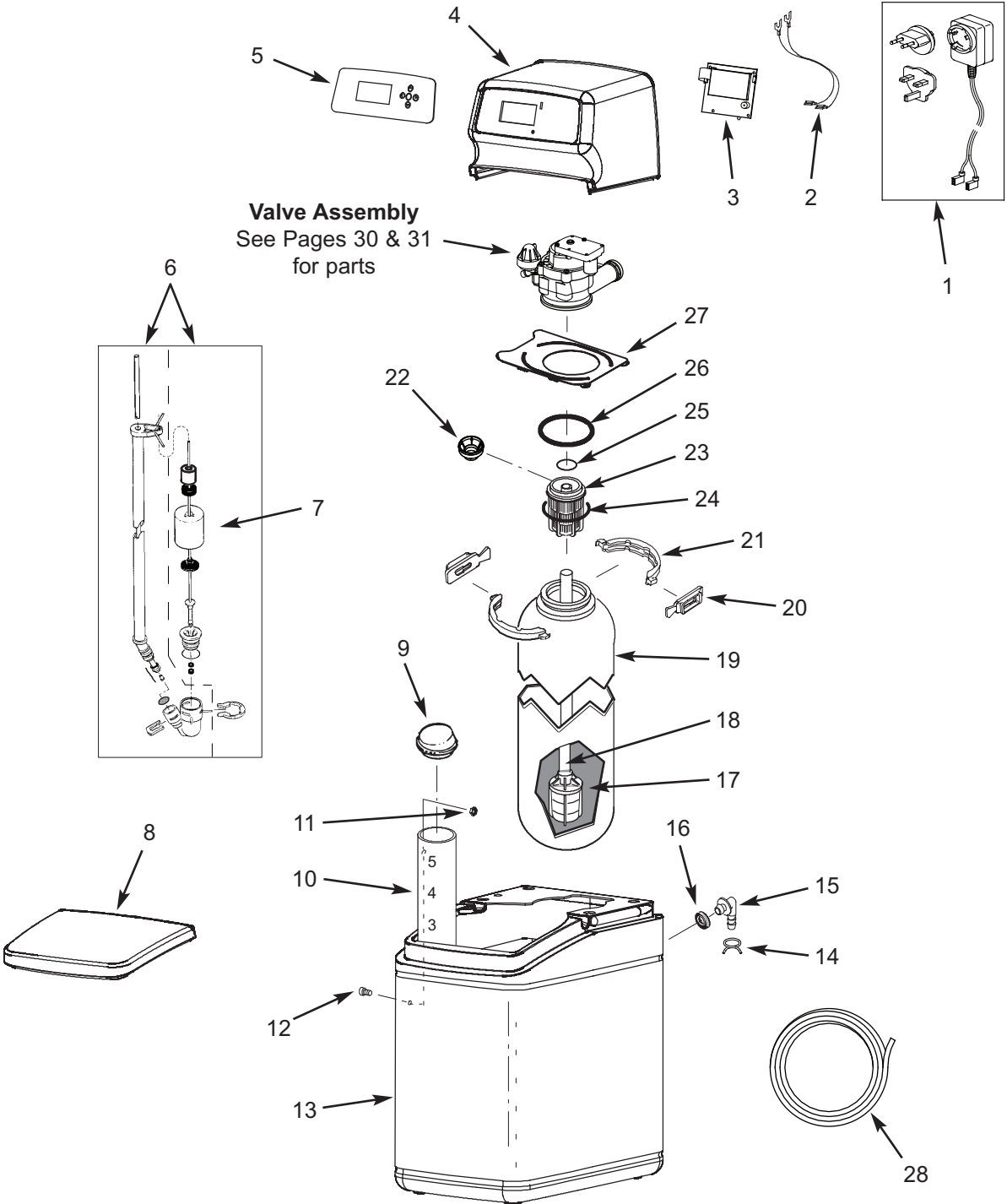

# Softener Parts List

Key No.	Part No.	Description
1	7366130	Power Supply, 24V DC, with Snap-in Plugs for Europe & UK
2	7250826	Power Cable
3	7388491	Repl. Electronic Controller (PWA)
4	7351876	Top Cover / Faceplate
5	7351884	Faceplate Decal / Keypad
6	7310113	Brine Valve Assembly, (Model VS 34)
	7310163	Brine Valve Assembly, (Model VS 74)
	7310202	Brine Valve Assembly, (Models VS 87 & VS 124)
7	7269516	Float, Stem & Guide Assembly (Model VS 34)
	7293395	Float, Stem & Guide Assembly (Model VS 74)
	7327568	Float, Stem & Guide Assembly (Models VS 87 & VS 124)
8	7337301	Salt Lid
9	0500283	Cover, Brinewell (Model VS 34)
	7155115	Cover, Brinewell (Models VS 74, VS 87 & VS 124)
10	7267043	Brinewell Assembly, including salt level decal (Model VS 34)
	7267027	Brinewell Assembly, including salt level decal (Model VS 74)
	7214375	Brinewell Assembly, including salt level decal (Model VS 87)
	7137824	Brinewell Assembly, including salt level decal (Model VS 124)
-	7331672	Brinewell Mounting Hardware Kit, Model VS 34 (includes Key Nos. 11-12)
-	7331698	Brinewell Mounting Hardware Kit, Models VS 74, VS 87 & VS 124 (includes Key Nos. 11 & 12)
11	↑	Nut (Model VS 34) or Washer (other VS models)
■	↑	Spacer (Model VS 34 only)
12	↑	Screw

■ Not illustrated

Key No.	Part No.	Description
13	7268918	Repl. Brine Tank (Model VS 34)
	7268934	Repl. Brine Tank (Model VS 74)
	7337424	Repl. Brine Tank (Model VS 87)
	7337408	Repl. Brine Tank (Model VS 124)
-	7331258	Overflow Hose Adaptor Kit (includes Key Nos. 14-16)
14	↑	Hose Clamp
15	↑	Adaptor Elbow
16	↑	Grommet
17	RMH001	Resin, per liter
	30437	Resin, 25 liter bag
18	7105047	Repl. Bottom Distributor
19	7268950	Resin Tank, 22.9 cm dia. x 35.6 cm (Model VS 34)
	7264037	Resin Tank, 20.3 cm dia. x 63.5 cm (Model VS 74)
	7114787	Resin Tank, 20.3 cm dia. x 88.9 cm (Model VS 87)
	7113058	Resin Tank, 20.3 cm dia. x 101.6 cm (Model VS 124)
-	7331177	Tank Neck Clamp Kit (includes 2 ea. of Key Nos. 20 & 21)
20	↑	Retainer Clip (2 req.)
21	↑	Clamp Section (2 req.)
22	7265025	Screen (Model VS 34 only)
23	7088855	Top Distributor (Model VS 34)
	7077870	Top Distributor (Models VS 74, VS 87 & VS 124)
-	7112963	Distributor O-Ring Kit (includes Key Nos. 24-26)
24	↑	O-Ring, 69.9 x 76.2 mm
25	↑	O-Ring, 20.6 x 27.0 mm
26	↑	O-Ring, 73.0 x 82.6 mm
27	7225499	Locking Plate
28	7139999	Drain Hose, 6 meters

# Valve Exploded View

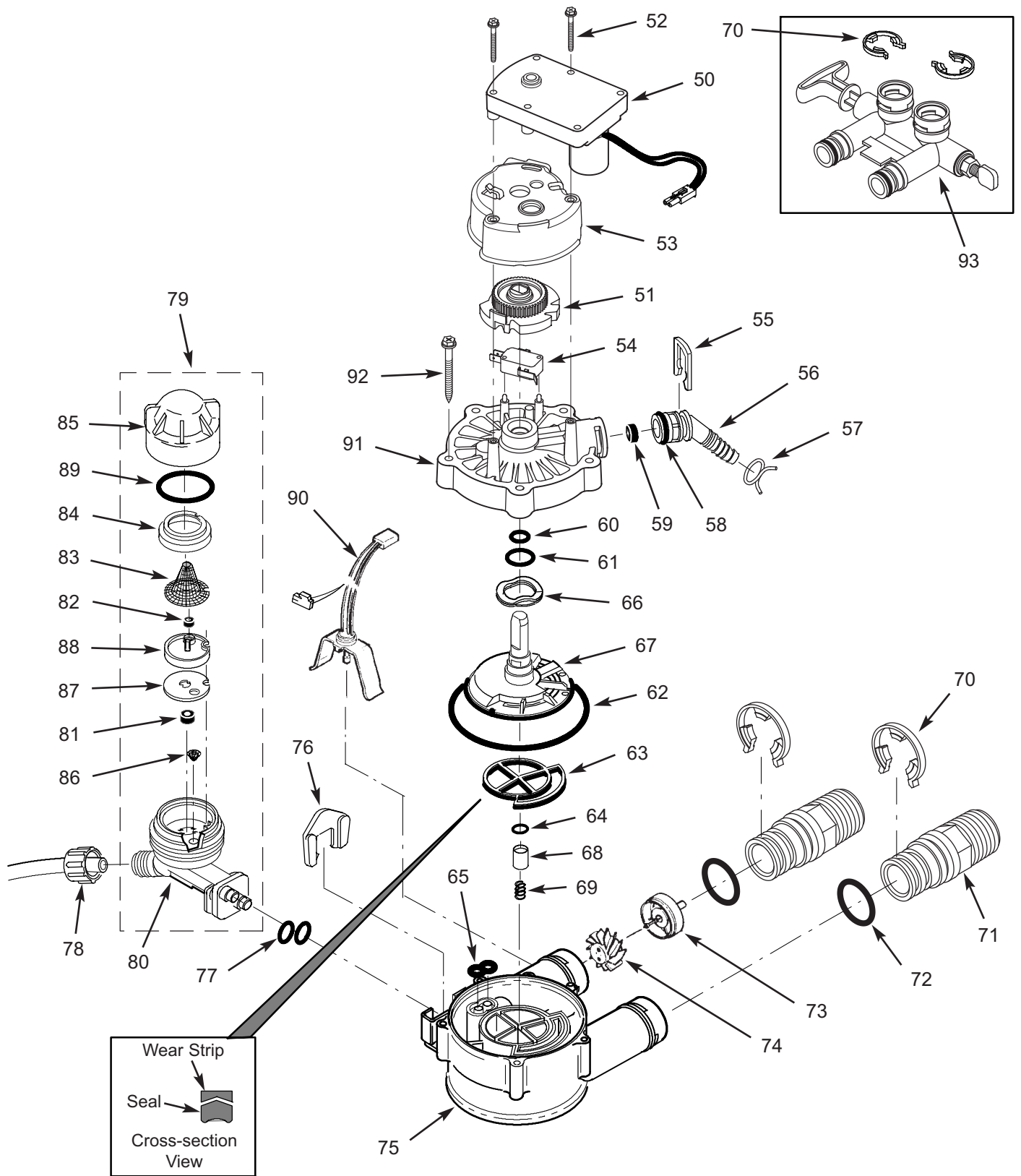

# Valve Parts List

Key No.	Part No.	Description
-	7384683	Motor, Cam & Gear Kit, 3/4" (includes Key Nos. 50-52)
50	↑	Motor
51	↑	Cam & Gear
52	7338111	Screw, #6-19 x 3.5 cm (2 req.)
53	7337474	Motor Mount
54	7030713	Switch
-	7331185	Drain Hose Adaptor Kit (includes Key Nos. 55-59)
55	↑	Clip, Drain
56	↑	Drain Hose Adaptor
57	↑	Hose Clamp
58	↑	O-Ring, 15.9 x 20.6 mm
59	↑	Flow Plug, 6.8 lpm
-	7129716	Seal Kit (includes Key Nos. 60-65)
60	↑	O-Ring, 11.1 x 15.9 mm
61	↑	O-Ring, 19.1 x 23.8 mm
62	↑	O-Ring, 85.7 x 92.1 mm
63	↑	Repl. Rotor Seal
64	↑	O-Ring, 9.5 x 14.3 mm
65	↑	Seal, Nozzle & Venturi
66	7082087	Wave Washer
67	7199232	Repl. Rotor & Disc
-	7342665	Drain Plug Kit, 3/4" (includes Key Nos. 64, 68 & 69)
68	↑	Plug, Drain Seal
69	↑	Spring
70	7337563	Clip, 3/4", pack of 4
71	7362110	Installation Adaptor, for 3/4" Valve, 1" BSPT, pack of 2, including 2 Clips, O-Rings & Silicone Grease (See Key Nos. 70 & 72)
72	7390668	O-Ring, 23.8 x 30.2 mm, pack of 2, including Silicone Grease
	7337571	O-Ring, 23.8 x 30.2 mm, pack of 4
-	7113040	Turbine & Support Assembly, including 2 O-Rings (See Key No. 72) & 1 ea. of Key Nos. 73 & 74
73	↑	Turbine Support & Shaft
74	↑	Turbine

Key No.	Part No.	Description
75	7082053	Valve Body
76	7081201	Retainer, Nozzle & Venturi
77	7342649	O-Ring, 6.4 x 9.5 mm, pack of 2
78	1202600	Nut - Ferrule
79	7268421	Nozzle & Venturi Assembly, Model VS 34 (includes Key Nos. 80-89)
	7238450	Nozzle & Venturi Assembly, Models VS 74, VS 87 & VS 124 (includes Key Nos. 76, 77 & 80-89)
80	7081104	Housing, Nozzle & Venturi
81	7084607	Fill Flow Plug, .57 lpm, (Model VS 34)
	1148800	Fill Flow Plug, 1.1 lpm, (Models VS 74, VS 87 & VS 124)
82	0521829	Flow Plug, .38 lpm
83	7146043	Screen
84	7167659	Screen Support
85	7199729	Cap
-	7298549	Repl. Nozzle, Venturi & Gasket Kit, Model VS 34 (includes Key Nos. 86-89)
	7290957	Repl. Nozzle, Venturi & Gasket Kit, Models VS 74, VS 87 & VS 124 (includes Key Nos. 86-89)
86	↑	Cone Screen
87	↑	Gasket, Nozzle & Venturi
88	↑	Disc, Nozzle & Venturi, White (Model VS 34)
	↑	Disc, Nozzle & Venturi, Red (Models VS 74, VS 87 & VS 124)
89	↑	O-Ring, 28.6 x 34.9 mm
90	7309803	Wire Harness, Position Switch
91	7337466	Valve Cover
92	7342657	Screw, #10-14 x 5 cm, pack of 5
93	7327631	Blending Bypass Valve, 3/4", Clip Style
■	7328051	Blending Bypass Valve, 3/4", Threaded ★

■ Not illustrated

★ Not included with softener