

Vitoflame 300

Type VHG, 18 to 33 kW

Pressure-jet oil burner

- With oil preheating
- For Vitoladens 300-T and Vitorondens 200-T/222-F

VITOFLAME 300

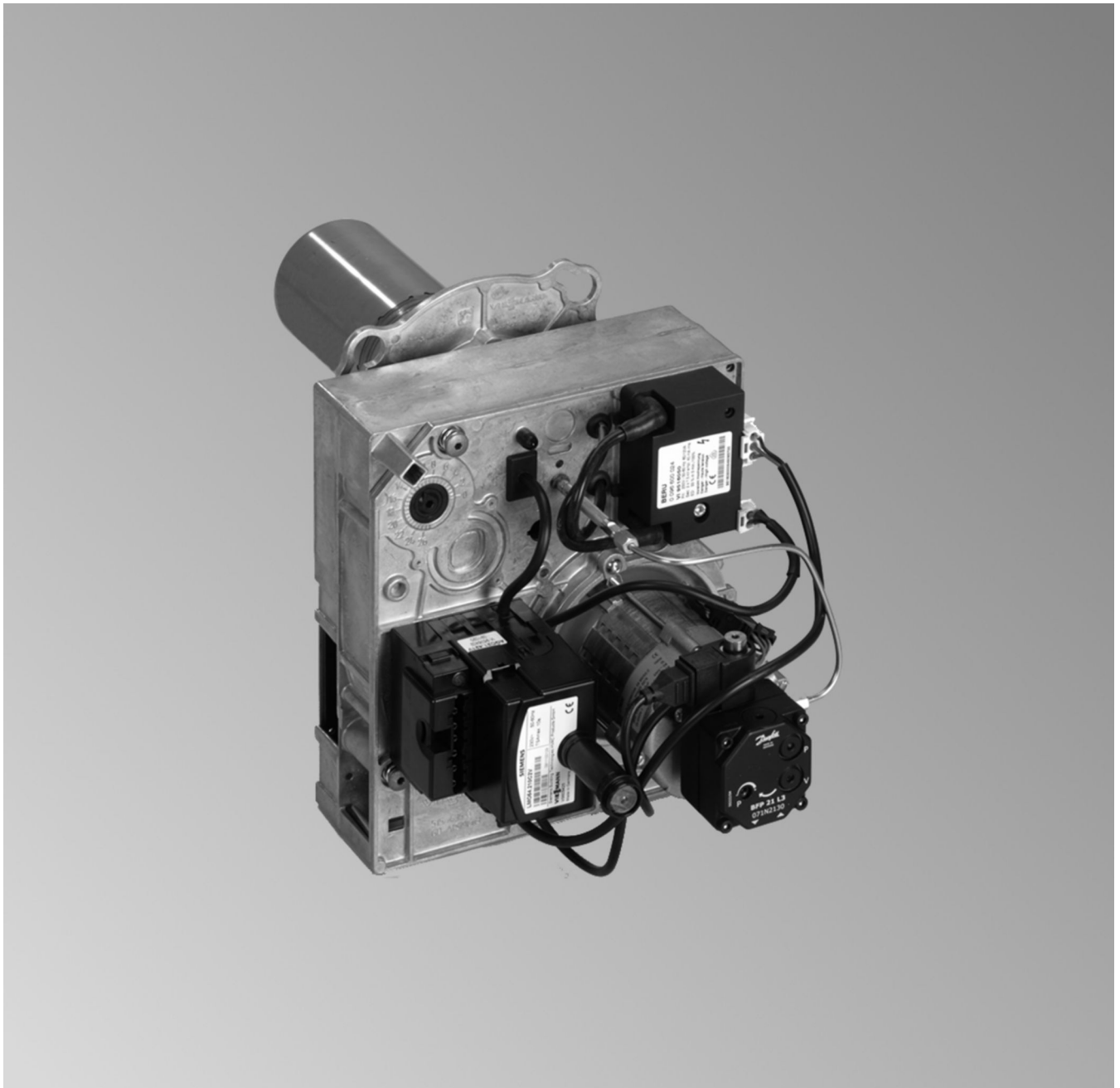

Safety instructions

-  Please follow these safety instructions closely to prevent accidents and material losses.

Safety instructions explained

-  **Danger**
This symbol warns against the risk of injury.

Note
Details identified by the word "Note" contain additional information.

-  **Please note**
This symbol warns against the risk of material losses and environmental pollution.

Target group

These instructions are exclusively intended for qualified contractors.

- Work on electrical equipment may only be carried out by a qualified electrician.
- The system must be commissioned by the system installer or a qualified person authorised by the installer.

Regulations to be observed

- National installation regulations
- Statutory regulations for the prevention of accidents
- Statutory regulations for environmental protection
- Codes of practice of the relevant trade associations
- Relevant country-specific safety regulations

Safety instructions for working on the system

Working on the system

- Isolate the system from the power supply (e.g. by removing the separate fuse or by means of a mains isolator) and check that it is no longer live.
- Safeguard the system against reconnection.

-  **Danger**
Hot surfaces can cause burns.
- Before maintenance and service work, switch OFF the appliance and let it cool down.
 - Never touch hot surfaces on the boiler, burner, flue system or pipework.

Safety instructions (cont.)

- !** **Please note**
 Electronic assemblies can be damaged by electrostatic discharge. Prior to commencing any work, touch earthed objects such as heating or water pipes to discharge static loads.

Repair work

- !** **Please note**
 Repairing components that fulfil a safety function can compromise the safe operation of the system. Replace faulty components only with genuine Viessmann spare parts.

Auxiliary components, spare and wearing parts

- !** **Please note**
 Spare and wearing parts that have not been tested together with the system can compromise its function. Installing non-authorised components and making non-approved modifications or conversions can compromise safety and may invalidate our warranty. For replacements, use only original spare parts supplied or approved by Viessmann.

Safety instructions for operating the system**If you smell flue gas**

- !** **Danger**
 Flue gas can lead to life threatening poisoning.
- Shut down the heating system.
 - Ventilate the installation site.
 - Close the doors to living spaces to prevent flue gases from spreading.

What to do if water escapes from the appliance

- !** **Danger**
 If water escapes from the appliance there is a risk of electric shock. Switch OFF the heating system at the external isolator (e.g. fuse box, domestic distribution board).
- !** **Danger**
 If water escapes from the appliance there is a risk of scalding. Never touch hot heating water.

Flue systems and combustion air

Ensure that flue systems are clear and cannot be sealed, for instance due to accumulation of condensate or other external causes. Ensure an adequate supply of combustion air. Instruct system users that subsequent modifications to the building characteristics are not permissible (e.g. cable/pipe-work routing, cladding or partitions).

- !** **Danger**
 Leaking or blocked flue systems, or an inadequate supply of combustion air can cause life threatening poisoning from carbon monoxide in the flue gas. Ensure the flue system is in good working order. Vents for supplying combustion air must be non-sealable.

Safety instructions (cont.)

Extractors

Operating appliances that extract air to the outside (extractor hoods, extractors, air conditioning units, etc.) can create negative pressure. If the boiler is operated at the same time, this can lead to a reverse flow of flue gas.











Danger







The simultaneous operation of the boiler and appliances that extract air to the outside can result in life threatening poisoning due to a reverse flow of flue gas. Fit an interlock circuit or take suitable steps to ensure an adequate supply of combustion air.

Index		
1. Information	Symbols	6
	Spare parts lists	6
2. Commissioning, inspection, maintenance	Steps - commissioning, inspection and maintenance	7
3. Burner control unit	Burner control unit LMO 64.301	14
	■ Program sequence during commissioning	14
	■ Function and fault indication by indicator light (LED)	15
	■ Burner fault flowchart	17
4. Troubleshooting	Diagnosis	18
	■ Fault indication with flash code	18
	■ Faults without flash code indication	19
5. Component overview	Component overview	22
6. Connection and wiring diagram	24
7. Standard values for burner adjustment	Standard values for burner adjustment	25
	■ Notes regarding burner settings for room sealed operation	25
8. Commissioning/service reports	Report	27
9. Specification	28
10. Final decommissioning	Final decommissioning and disposal	29
11. Keyword index	30

Symbols

Symbol	Meaning
	Reference to other document containing further information
	Step in a diagram: The numbers correspond to the order in which the steps are carried out.
	Warning of material losses and environmental pollution
	Live electrical area
	Pay particular attention.
	<ul style="list-style-type: none"> ▪ Component must audibly click into place. or ▪ Acoustic signal
	<ul style="list-style-type: none"> ▪ Fit new component. or ▪ In conjunction with a tool: Clean the surface.
	Dispose of component correctly.
	Dispose of component at a suitable collection point. Do not dispose of component in domestic waste.

The steps in connection with commissioning, inspection and maintenance are found in the "Commissioning, inspection and maintenance" section and identified as follows:

Symbol	Meaning
	Steps required during commissioning
	Not required during commissioning
	Steps required during inspection
	Not required during inspection
	Steps required during maintenance
	Not required during maintenance

Spare parts lists

Information about spare parts can be found on the Viessmann spare parts app.





Steps - commissioning, inspection and maintenance

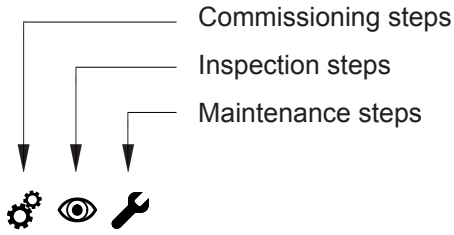

Page

•		1. Commissioning the system.....	8
•	•	2. Adjusting the air volume.....	8
•	•	3. Adjusting the oil pressure and checking the vacuum.....	8
•	•	4. Testing the burner and entering the actual values into the report.....	10
•	•	5. Shutting down the system	
•	•	6. Checking the firm seating of electrical connections	
•	•	7. Cleaning the burner.....	10
•	•	8. Checking the impeller fixings	
•	•	9. Checking the flame tube fixings	
•	•	10. Replacing the nozzle.....	11
•	•	11. Checking and adjusting the mixing assembly.....	11
•	•	12. Fitting the burner cover on the burner casing	
•	•	13. Cleaning the oil pump filter and replacing it if required.....	12
•	•	14. Replacing the filter element of the fuel oil filter	
•	•	15. Commissioning the system	
•	•	16. Checking the oil lines and connections for leaks	
•	•	17. Re-testing the burner and entering the actual values into the report	





Commissioning the system

To obtain optimum combustion values, it is essential to adjust the burner with the boiler at operating temperature (min. 60 °C).

ⒸH: The limits of the Swiss Clean Air Regulations LRV 92 must be maintained.

 Boiler control unit service instructions

Note

The Vitoflame 300 pressure-jet oil burner features very good combustion values which are achieved without the use of fuel oil additives (combustion improvers). The use of combustion improvers that leave residues is not permissible.

1. Check the heating system pressure and the oil level in the tank.

2. Open the shut-off valves in the oil lines on the oil tank and on the filter.
3. Fill the oil suction line and the filter with fuel oil using a manual oil suction pump **before** switching the burner on.
4. Switch ON the mains isolator (outside the installation room).
5. Switch ON the system ON/OFF switch at the control unit.
If the fault indicator on the control unit illuminates, press the reset button on the burner (see chapter "Function and fault indication by indicator light (LED)").



Adjusting the air volume

The air volume is preset at the factory. Readjust the air volume if necessary.

When commissioning the burner, some fine adjustment may be required.

Before making adjustments, check whether inlet air aperture Ⓒ inside the casing is set to "8.0" (factory setting).

1. Check the static burner pressure at test connector Ⓑ; to do so, remove the plastic cap.

Note

The actual static burner pressure must not vary from the standard values: See chapter "Standard values for burner adjustment".

2. If required: Adjust the static burner pressure at air damper Ⓐ:

Anti-clockwise turn:

- Higher static burner pressure
- More air
- Lower CO₂ content

Clockwise turn:

- Lower static burner pressure
- Less air
- Higher CO₂ content

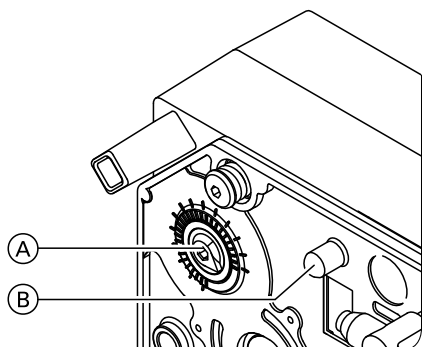

Fig. 1

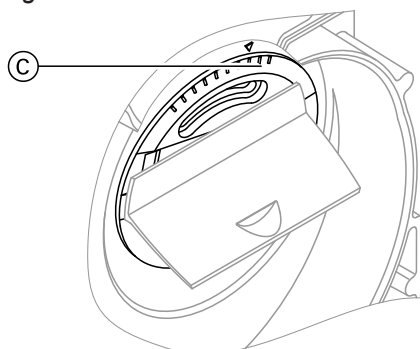

Fig. 2



Adjusting the oil pressure and checking the vacuum

The oil pressure is factory-set according to the oil throughput. Readjust the oil pressure if necessary.



Adjusting the oil pressure and checking the... (cont.)

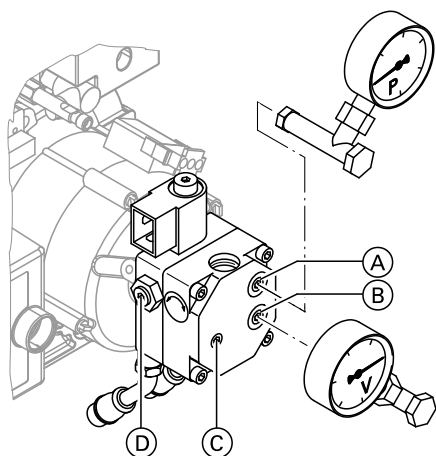

Fig. 3 Danfoss oil pump, type BFP 21 LE or LES, or BFP 31 LE

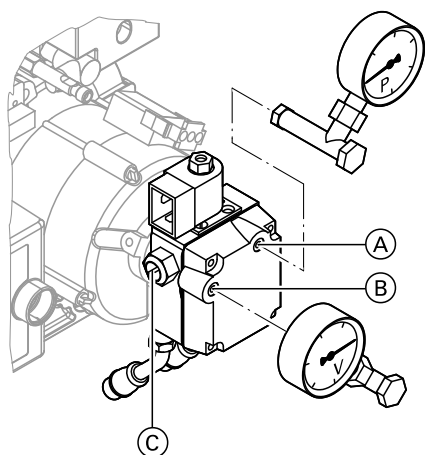

Fig. 4 Suntec oil pump, type ALE 35

1. Switch off at mains isolator and safeguard against reconnection.
2. Unscrew plug "P" (A) from the oil pump.
3. Unscrew plug "V" (B) from the oil pump.

Note

Place a suitable container below, to catch any oil that may leak out.

4. Insert pressure gauge (measuring range 0 to 25 bar/2.5 MPa) and vacuum gauge (measuring range 0 to 1 bar/0.1 MPa).

Note

Only seal in the pressure gauge and vacuum gauge with copper or aluminium gaskets or with O-rings. Never use sealing tape.

5. Start the burner.

Note

The solenoid valve opens.

6. Read off the oil pressure and vacuum of the pump at the pressure gauge and vacuum gauge. The vacuum must not exceed 0.3 bar/0.03 MPa at a height difference of 3 m between the oil pump and the bottom of the tank.

Note

Vacuum greater than 0.3 bar/0.03 MPa: Check the filter for contamination and check the pipe run.

7. If necessary, adjust the oil pressure at oil pump pressure setting screw (C).
 - Clockwise turn: Pressure rises
 - Anti-clockwise turn: Pressure falls

Note

Only with Danfoss oil pump, type BFP 21 LE or BFP 31 LE:

The LE nozzle shut-off function must be adjusted at LE setting screw (D) (LE = ON), located on the l.h. side of the oil pump.

Note

For standard values for burner adjustment, see the chapter with the same title.

8. Test to check the actual emission values after adjusting the oil pressure.
9. Switch system OFF at mains isolator and safeguard against unauthorised reconnection.
10. Undo the pressure and vacuum gauges.



Adjusting the oil pressure and checking the... (cont.)

11. Check the plug seal rings for damage and replace if necessary.
Insert plugs "P" (A) and "V" (B).
12. Start the burner and check the plugs for leaks.



Testing the burner and entering the actual values into the report

Note

In the case of room sealed operation, observe the information regarding burner adjustments in the chapter with the same title.



Shutting down the system



Checking the firm seating of electrical connections



Cleaning the burner

 For cleaning the combustion chamber and flues, see boiler service instructions.

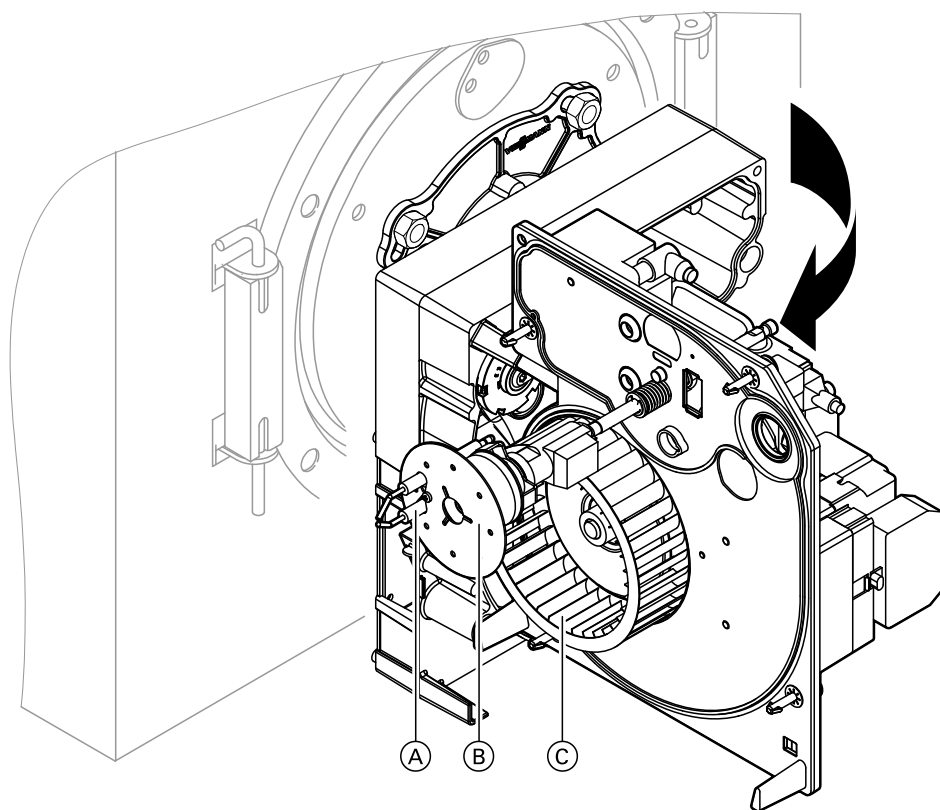

Fig. 5

1. Bring the burner into its maintenance position.
2. Clean casing, flame tube, mixing assembly (B), ignition electrodes (A) and impeller (C).



Checking the impeller fixings



Checking the flame tube fixings



Replacing the nozzle

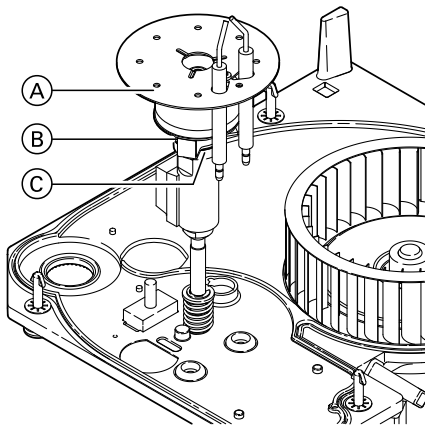

Fig. 6

1. Place the burner cover with the blast tube connection facing upward on the burner casing (service position). This prevents the formation of bubbles in the blast tube connection.
2. Turn fixing screw (B) through two full turns to undo.
3. Remove mixing assembly (A) from the blast tube connection.
4. Replace the nozzle (counterholding the blast tube connection).

Note

For the make and type of nozzle, see Standard values for burner adjustment in the chapter of the same title.

5. Push mixing assembly (A) onto the blast tube connection as far as end-stop (C) (spacers) of the oil preheater.
6. Use suitably sized spacers (C) to adjust distance "a" between the nozzles, in line with the table in chapter "Checking and adjusting the mixing assembly"
7. Retighten fixing screw (B).

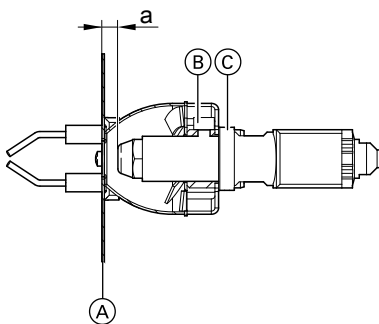

Fig. 7



Checking and adjusting the mixing assembly

Check ignition electrodes (A) for wear, contamination and dimensional accuracy (see diagram), and replace if necessary.

Prior to installation, check sealing face (D) of baffle plate (B) to the flame tube for damage and contamination.

   **Checking and adjusting the mixing assembly (cont.)**

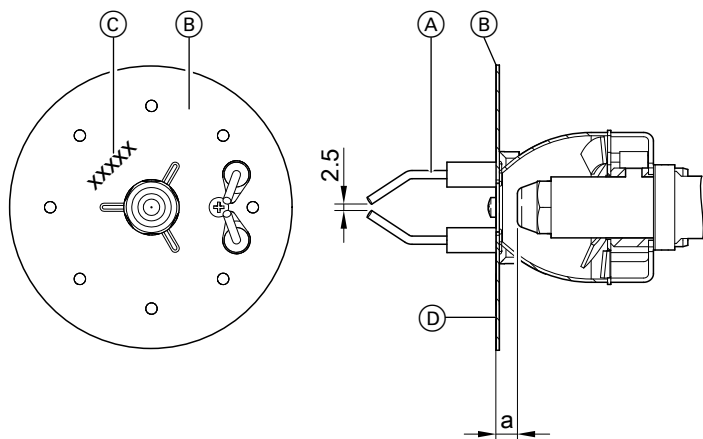



Fig. 8

Rated heating output	kW	18	22	27	33
Designation ©		VHG I-2	VHG I-3	VHG I-4	VHG I-5
Dimension a	mm	2.5	6.5	2.0	5.0

   **Fitting the burner cover on the burner casing**

   **Cleaning the oil pump filter and replacing it if required**

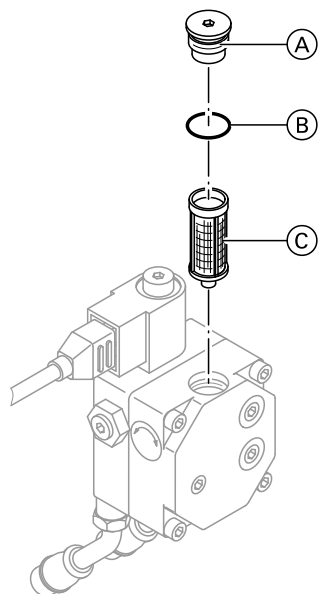

Fig. 9 Danfoss oil pump, type BFP 21 LE / LES or BFP 31 LE

- (A) Filter plug
- (B) O-ring (replace)
- (C) Filter (replace)



Cleaning the oil pump filter and replacing it... (cont.)

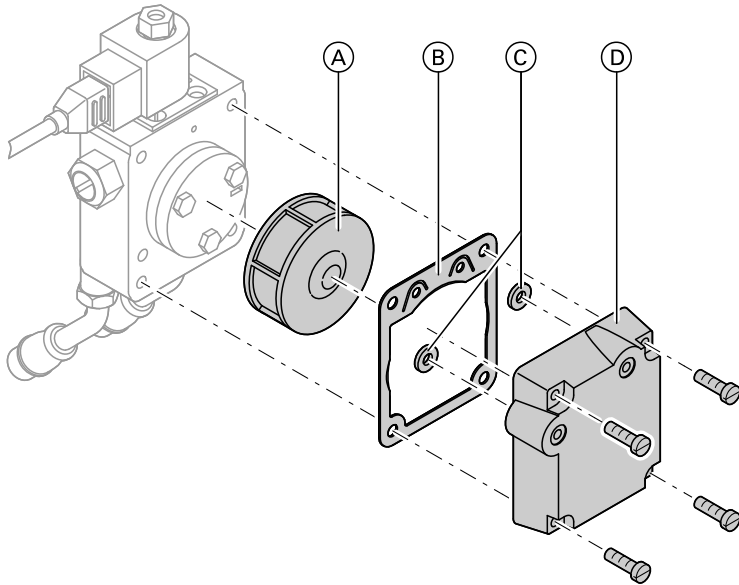

Fig. 10 Suntec oil pump, type ALE 35

- | | |
|-------------------------------|-----------------------|
| (A) Filter (clean or replace) | (C) O-rings (replace) |
| (B) Flat gasket (replace) | (D) Cover |



Replacing the filter element of the fuel oil filter



Commissioning the system



Checking the oil lines and connections for leaks



Re-testing the burner and entering the actual values into the report

Burner control unit LMO 64.301

! Please note
 An incorrect burner control unit prevents the burner from switching off when the set boiler water temperature has been reached and can cause damage to the burner. The burner is locked out if the high limit safety cut-out responds.
 Only use **burner control unit LMO 64.301**.

Program sequence during commissioning

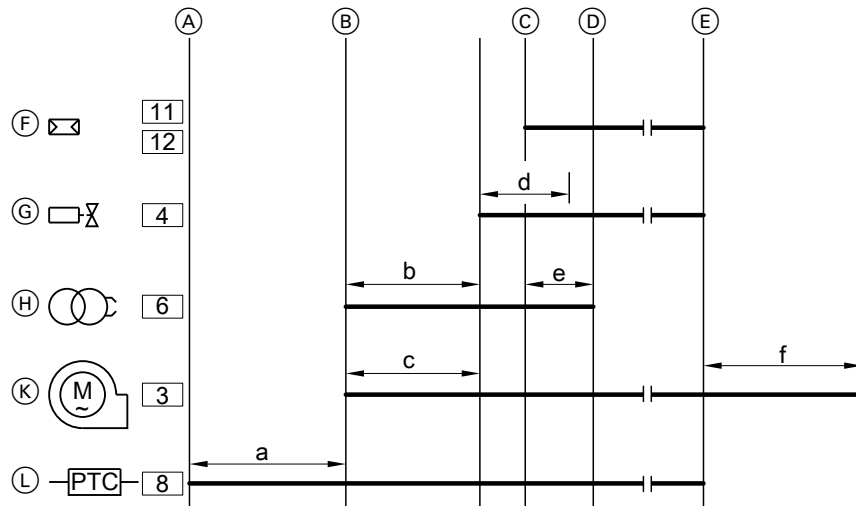

Fig. 11

- (A) Start of oil preheat time
- (B) Start-up begins
- (C) Point of flame formation
- (D) Operating position
- (E) Controlled shutdown
- [3] to [12] Screwless terminals at the burner control unit
- (F) Flame monitor
- (G) Solenoid valve on the oil pump
- (H) HF ignition unit
- (K) Burner motor
- (L) Oil preheater

a	Oil preheat time	up to 2 min ^{*1}
b	Pre-ignition time	approx. 15 s
c	Pre-flushing time	approx. 15 s
d	Safety time	max. 10 s
e	Post-ignition time when flame is established	approx. 3 s
f	Post-flushing time	approx. 90 s

Note
 If power supply is 2 × 127 V and red flash code: 10 x flashing (see chapter "Faults with flash code indication"), contact your local Viessmann sales office.

Controlled intermittent operation

After a maximum of 24 hours non-stop operation, the burner control unit initiates an automatic safety shutdown with subsequent restart.

Flame monitor sensor current

- Min. required 45 µA
- Max. permissible without flame 5.5 µA

Control sequence in the event of faults

If a fault shutdown occurs, the outputs for the fuel valves and the ignition system are immediately switched off (< 1 s).

Undervoltage

If the mains voltage drops below 165 V~, the burner control unit initiates a safety shutdown. The system restarts when the mains voltage rises above approx. 175 V~.

^{*1} Subject to the temperature of the fuel oil supplied.

Burner control unit LMO 64.301 (cont.)

Cause	Response
After a power failure	Restart
After falling below the undervoltage level	Restart
If there is a premature, faulty flame signal during pre-flush time c	Fault shutdown at the end of pre-flush time c
If there is a premature, faulty flame signal during oil preheat time a	Starting is prevented, fault shutdown after max. 40 s
If the burner does not light within the safety time TSA	Fault shutdown at the end of the safety time TSA
If the flame fails during operation	Max. 3 restarts, then fault shutdown
No heating or enabling of oil preheater within 10 min	Fault shutdown

Fault shutdown

After a fault shutdown, the burner control unit remains locked out (non-modifiable fault shutdown) and the red indicator light illuminates. This state is also maintained if the power supply fails.

Resetting the burner control unit

The system can be immediately reset after a fault shutdown. Hold down the reset button for approx. 1 s (< 3 s).

Ignition sequence

If the flame fails within the safety time, the system re-ignites, but only until the end of the maximum safety time. This allows several ignition attempts within the safety time; see the above program sequence.

Repeat limitation

In the event of flame failure during operation, up to 3 re-ignition attempts can be made. The fourth flame failure during operation triggers a fault shutdown.

Counting of the repeats begins anew with each of the following controlled starts:

- Via temperature controller or pressure regulator
- Via temperature limiter or pressure switch
- Via safety limiter

Function and fault indication by indicator light (LED)

During standard operation, the operating conditions are indicated by colour codes at the end of reset button **A** (see the following table). The indicator permanently illuminates red after a fault shutdown. In this condition, the visual fault cause indication can be activated (see the following chapter "Burner fault flow-chart").

Burner control unit LMO 64.301 (cont.)

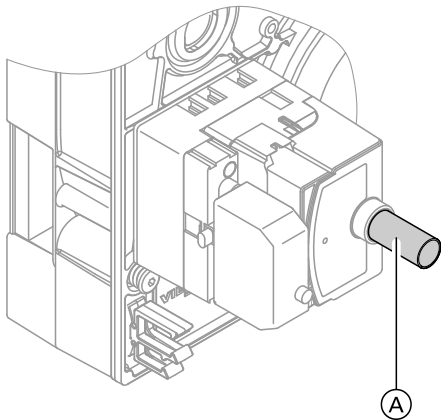

Fig. 12

1. Press reset button (A) for approx. 5 s (> 3 s) until the signal lamp illuminates yellow.
2. A flash code is then shown as fault indication. Meaning of the flash code: See the table in chapter "Faults with flash code indication".
3. To reset the burner and exit the fault indication function, press the reset button for approx. 1 s (< 3 s).

LED colour	Operating condition
Constant yellow	Oil preheater active, oil preheat time a
Flashing yellow	Ignition phase pre-purge, ignition activated
Constant green	Operation, flame stable
Flashing green	Operation, poor flame stability
Flashing yellow-red alternately	Undervoltage (< 165 V)
Constant red	Fault, burner locked out
Flashing red	Fault indication with flash code (for meaning see chapter "Fault indication with flash code")
Green-red alternately	External light before burner start
Flickering red	Interface diagnosis For diagnosis with interface adaptor (accessories)

Burner control unit LMO 64.301 (cont.)

Burner fault flowchart

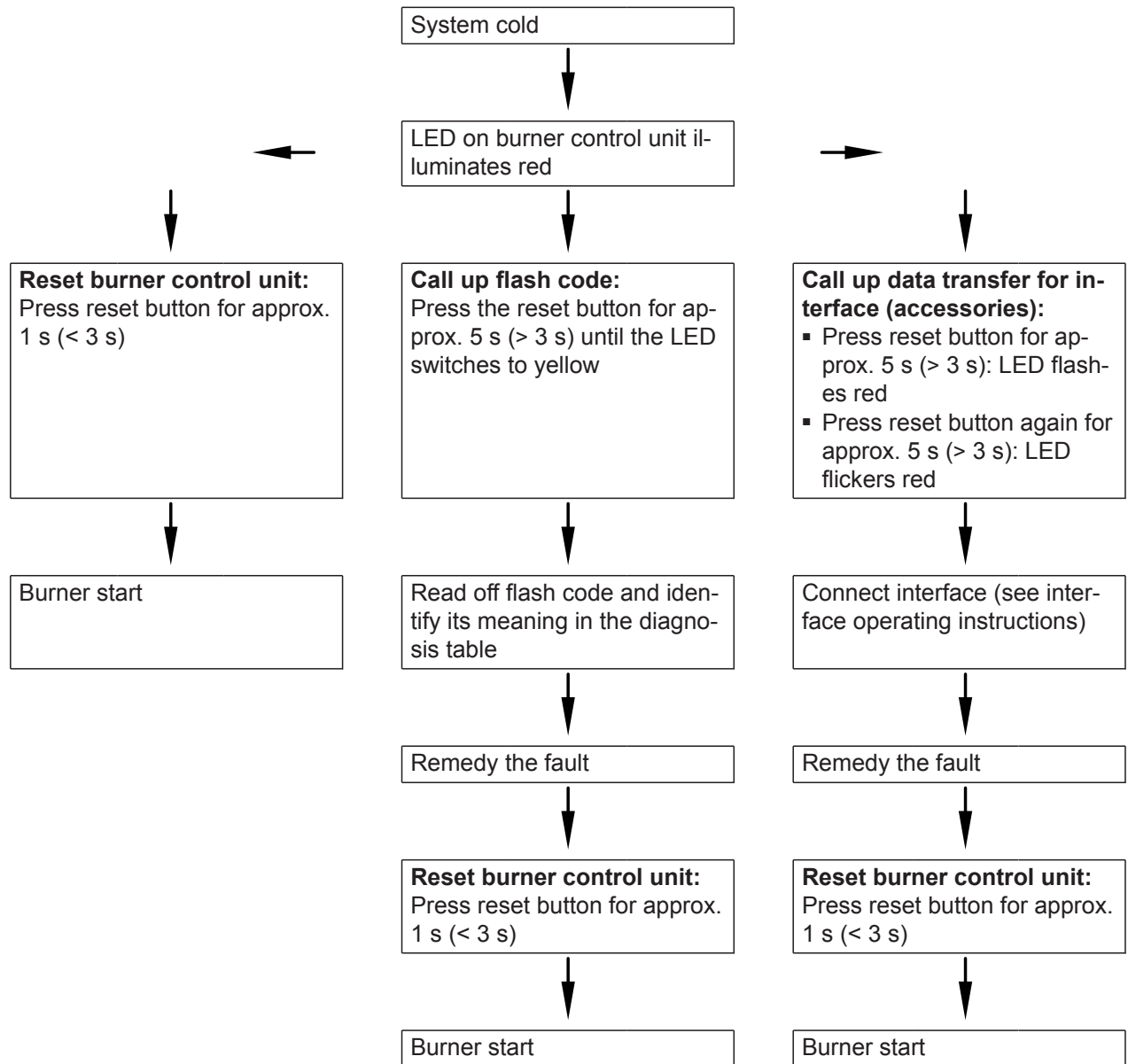

Functions

Diagnosis

Fault indication with flash code

Fault	Red flash code	Cause of fault	Measure
Burner does not start (with fault indication), indicator light illuminates.	10 x	Electrical connection faulty, wires "L 1" and "N" interchanged or burner control unit faulty.	Check the electrical connection. If phases are correctly connected, replace burner control unit.
	10 x	External voltage at "S3" or "B4"	Check the electrical connection (see chapter "Connection and wiring diagram").
Burner does not start (with fault indication).	2 x	Motor faulty	Replace motor.
	2 x	Coupling between motor and oil pump faulty	Replace coupling.
	2 x	Oil pump seized up or sluggish.	Clean oil pump or replace it.
	8 x	Oil preheater faulty	Replace oil preheater.
Burner starts, but no flame is formed.	2 x	Ignition electrodes incorrectly adjusted	Adjust correctly (see chapter "Checking and adjusting the mixing assembly").
	2 x	Ignition electrodes damp and contaminated	Clean ignition electrode block.
	2 x	Insulation body of ignition electrodes cracked	Replace ignition electrode block.
	2 x	Ignition transformer faulty	Replace ignition transformer.
	2 x	Ignition cable faulty	Replace ignition cable.
	2 x	Pump does not supply oil.	Mount pressure gauge and vacuum gauge at the pump and check build-up of pressure (see following paragraph).
Burner starts; flame extinguishes during the start phase	2 x	Timer is faulty. Fan motor does not temporarily switch off when the solenoid valve switches on.	Check the timer is working; replace if necessary.
	2 x	Recirculation gap set incorrectly	Set recirculation gap correctly (see chapter "Checking the recirculation gap" if included).
Pump does not supply oil.	2 x	Shut-off valves closed at filter or in oil line	Open valves.
	2 x	Filter blocked	Clean filters (fuel oil filter and pump filter), replace if necessary.
	2 x	Coupling between motor and pump faulty	Replace coupling.
	2 x	Leak in suction line or filter bowl	Retighten fittings. Check oil lines and connections for leaks and tighten if required.
	2 x	Oil flow and return hoses interchanged.	Correct the connections in line with the marking on the pump.
	2 x	Vacuum in suction line too high (above 0.3 bar)	Check sizing of oil line cross-section. Replace filter. Check external fuel oil valve.
	2 x	External anti-lift valve is faulty.	Check external anti-lift valve; replace if necessary.

Diagnosis (cont.)

Fault	Red flash code	Cause of fault	Measure
Fan motor faulty	2 x	Fan motor occasionally does not start, due to faulty auxiliary winding or capacitor.	Replace the motor or capacitor.
Burner starts, but no oil is injected.	2 x	Solenoid valve coil is faulty.	Replace solenoid valve coil.
	2 x	Oil pump is faulty.	Replace oil pump.
	2 x	Nozzle is blocked.	Replace nozzle.
External light during the pre-purge phase	4 x	Oil pump solenoid valve fails to close.	Replace oil pump.
	4 x	Ignition electrodes incorrectly adjusted or worn	Check ignition electrodes; replace if necessary.
Burner starts and flame builds, but burner enters fault state after safety time expires.	2 x	Burner control unit faulty	Replace burner control unit.
	2 x	Carbon deposits on flame tube or mixing assembly	Clean flame tube and mixing assembly.
Flame tears off during operation	7 x	Air in suction line	Seal line and filter.
	7 x	Flue gas recirculation	Check the flue. Carry out annular gap test.
	7 x	Condensate backup	Check condensate drain.
	7 x	Nozzle faulty	Replace nozzle.
	7 x	Incorrect burner setting	Check the default settings in line with chapter "Standard values for burner adjustment".
	7 x	Sensor plate contaminated	Clean sensor plate.
Ignition switches on during operation	7 x	Sensor plate contaminated	Clean sensor plate.
	7 x	Nozzle contaminated or faulty	Replace nozzle.
	7 x	Condensate backup in flue gas heat exchanger	Clean siphon and neutralising system.
	7 x	Heating surfaces of flue gas heat exchanger are contaminated	Clean the heating surfaces of the flue gas heat exchanger.

! Please note
 An incorrect burner control unit prevents the burner from switching off when the set boiler water temperature has been reached and can cause damage to the burner. The burner is locked out if the high limit safety cut-out responds.
 Only use **burner control unit LMO 64.301**.

Faults without flash code indication

Fault	Cause of fault	Measure
Burner does not start (no fault indication), indicator light does not illuminate.	No power	Check fuse or plug-in connector 150 in the control unit, check electrical connections, check position of the system ON/OFF switch on the control unit and of the mains isolator.
	High limit safety cut-out has responded.	Press the reset button at the boiler control unit.



Diagnosis (cont.)

Fault	Cause of fault	Measure
Flame pulsates, tears off.	Fan pressure too high	Check the static burner pressure at the test connector on top of the fan casing (U-tube pressure gauge). Adjust the air damper and blast tube connection so that the lower static burner pressure (see chapter "Standard values for burner adjustment") is not exceeded.
	CO ₂ content too low	Check the setting.
	Excessive oil throughput	Set the oil pressure correctly (see chapter "Standard values for burner adjustment").
	Condensate backup in flue gas heat exchanger	Clean siphon and neutralising system.
	On-site condensate drain blocked	Clean condensate drain.
	Condensate lifting pump (if installed) faulty	Replace condensate lifting pump.
	Heating surfaces of boiler or flue gas heat exchanger dirty	Clean heating surfaces of boiler or flue gas heat exchanger.
	In balanced flue operation, flue gas is drawn in via the annular gap in the flue system.	Test annular gap (measure directly at burner connection adaptor). If flue gas is detected, remedy the leak in the flue system. Immediate remedy: Temporarily operate the burner in open flue mode.
	If other combustion equipment is connected to the same chimney, flue gas may also be drawn in.	Observe installation regulations.
	Flue gas from other combustion equipment is drawn in via annular gap.	Extend flue on site, for example.
Burner sooty; higher CO concentration in flue gas.	Nozzle faulty	Replace nozzle.
	Insufficient or too much air	Correct the settings. Check and clean impeller. Check ventilation in installation room.
	Insufficient chimney draught	Check chimney and flue gas routing.
	Nozzle faulty	Replace the nozzle, fit the right nozzle (see chapter "Standard values for burner adjustment").
	Flue gas in the combustion air supply	Check the flue system for tightness.
	Insufficient combustion air supply	Check combustion air supply.
	In balanced flue operation, flue gas is drawn in as well.	Check flue system.
Condensate backup in flue gas heat exchanger	Clean siphon and neutralising system.	
CO ₂ content too low	Incorrect setting	Check setting (see chapter "Standard values for burner adjustment").
	Infiltrating air	Seal flue pipe at boiler flue connection. Retighten screws on the boiler door and on the flue outlet cover.

Diagnosis (cont.)

Fault	Cause of fault	Measure
Excessive flue gas temperature	Excessive oil throughput	Match oil throughput to rated boiler heating output.
	Boiler and flue gas heat exchanger dirty	Clean boiler and flue gas heat exchanger; correct burner settings.
	Air in flue gas heat exchanger	Vent flue gas heat exchanger.
	Insufficient circulation volume due to faulty heating circuit pump	Check the heating circuit pump; replace if necessary.
	Incorrect hydraulic connection; not all heating circuits are connected to the flue gas heat exchanger.	Connect all heating circuits to the flue gas heat exchanger.
Burner operates, constantly flickering red light on burner control unit.	No fault, interface diagnosis	Press reset button > 3 s.

Component overview

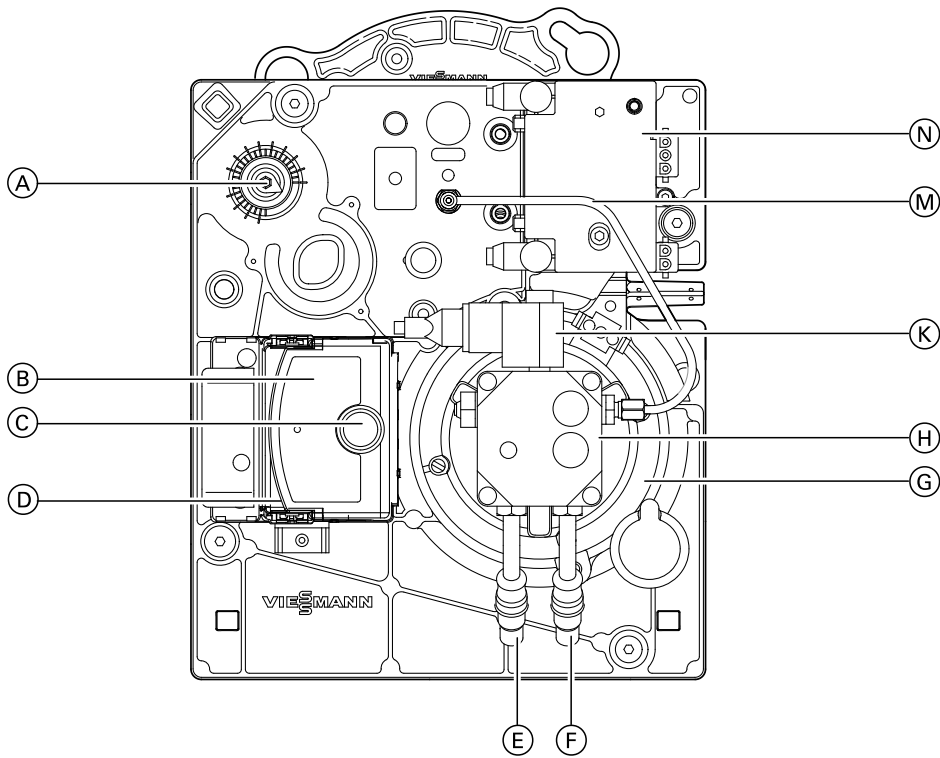

Fig. 13

- | | |
|-------------------------------|---|
| Ⓐ Air regulating valve | Ⓒ Fan motor |
| Ⓑ Burner control unit | Ⓓ Oil pump |
| Ⓒ Reset button with extension | Ⓔ Solenoid valve |
| Ⓓ Connection panel | Ⓕ Oil line |
| Ⓔ Return line | Ⓖ HF ignition unit
(with flame monitoring) |
| Ⓕ Suction line | |

Component overview (cont.)

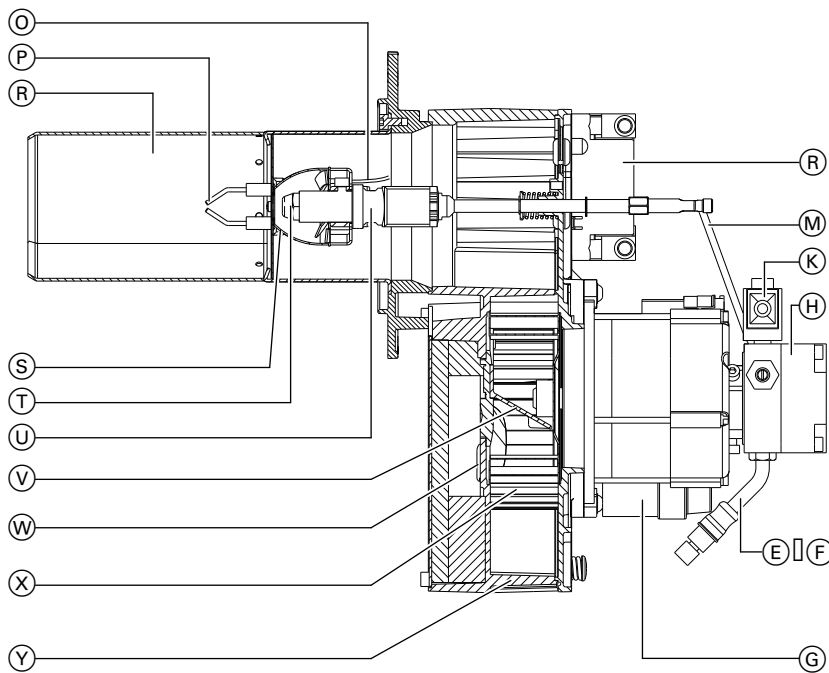

Fig. 14

- | | |
|---|--|
| (E) Return line | (P) Ignition electrodes |
| (F) Suction line | (R) Flame tube |
| (G) Fan motor | (S) Mixing device |
| (H) Oil pump | (T) Oil burner nozzle |
| (K) Solenoid valve | (U) Blast tube connection with oil preheater |
| (M) Oil line | (V) Air routing |
| (N) HF ignition unit
(with flame monitoring) | (W) Air intake |
| (O) Ignition cable | (X) Impeller |
| | (Y) Burner casing |

! **Please note**

An incorrect burner control unit prevents the burner from switching off when the set boiler water temperature has been reached and can cause damage to the burner. The burner is locked out if the high limit safety cut-out responds.

Only use **burner control unit LMO 64.301**.

Connection and wiring diagram

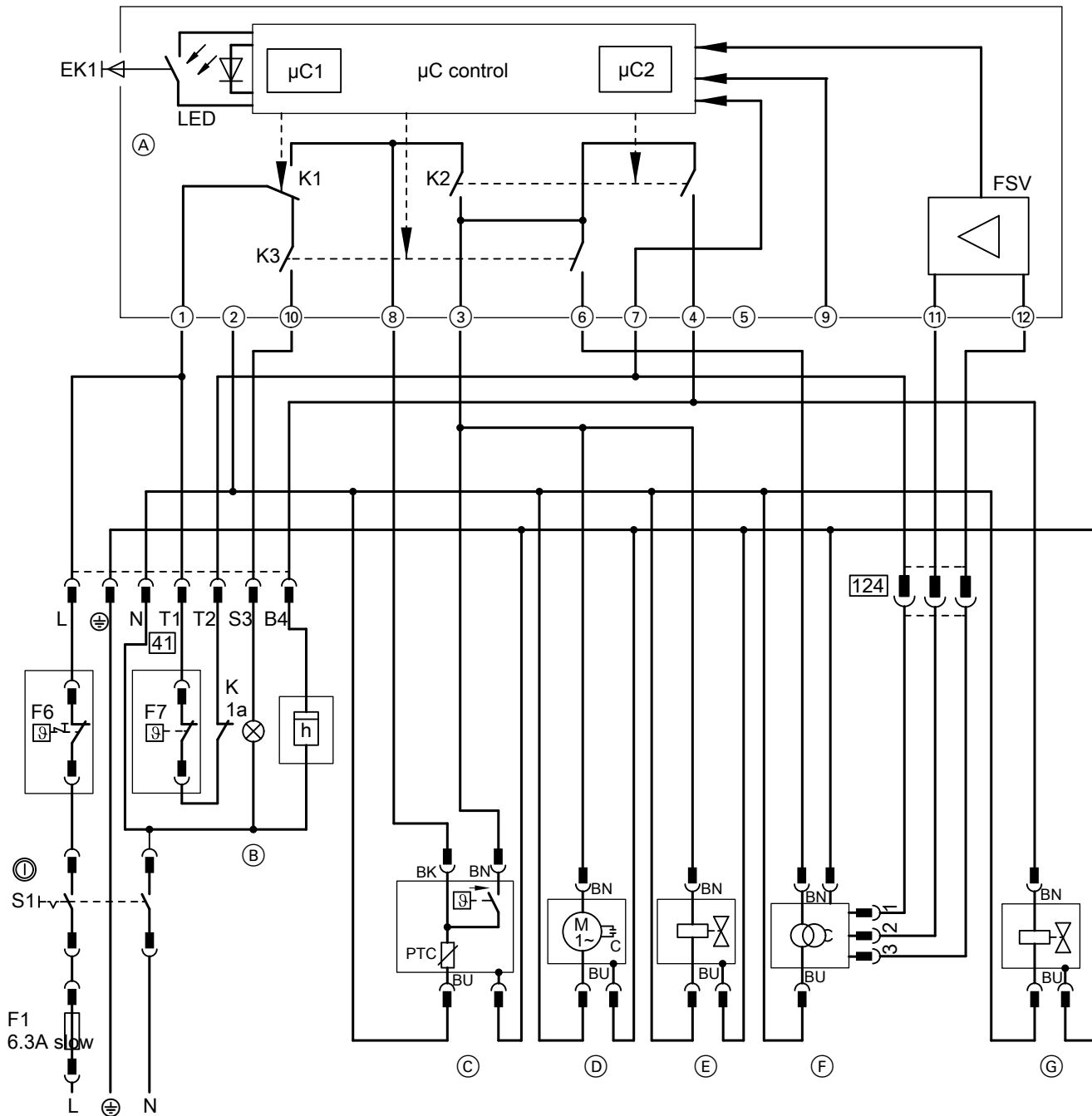

Fig. 15

Note
 This wiring diagram only applies in conjunction with Viessmann products.

- 41 Burner plug at the control unit
- F1 Fuse in the control unit
- F6 High limit safety cut-out
- F7 Temperature controller
- S1 ON/OFF switch on the control unit
- S2 Reset button
- K1-K3 Relay contacts
- K1a Control unit relay contact
- 1 - 12 Screwless terminals at the burner control unit
- A Burner control unit (see chapter "Program sequence during commissioning")
- B Fault indicator on the control unit

- C Oil preheater
- D Burner motor
- E Solenoid valve for external connection via separate adaptor
- F HF ignition unit with flame monitor
- G Solenoid valve on the oil pump

Colour coding to IEC 60757

BK	Black
BN	Brown
BU	Blue

Standard values for burner adjustment

Notes regarding burner settings for room sealed operation

The burner must be adjusted with all associated pipes adapted and connected (e.g. ventilation air, flue gas).

Once it has been adjusted, no further pipes may be connected and existing pipes may not be removed or altered.

If using room sealed or coaxial ventilation air and flue systems

To adjust the burner settings, the boiler water temperature must be at least 60 °C.

If using separate or parallel ventilation air and flue systems

If, at the time when burner settings are made, the outside air temperature is not +15 °C, we recommend adjusting the CO₂ value by regulating the air volume in accordance with the following table. For the adjustment procedure, see chapter "Adjusting the air volume"; standard values for air damper and blast tube connection settings can vary slightly on account of geodetic height, air pressure and temperature.

When making the adjustments, also take account of the **average** local air pressure.

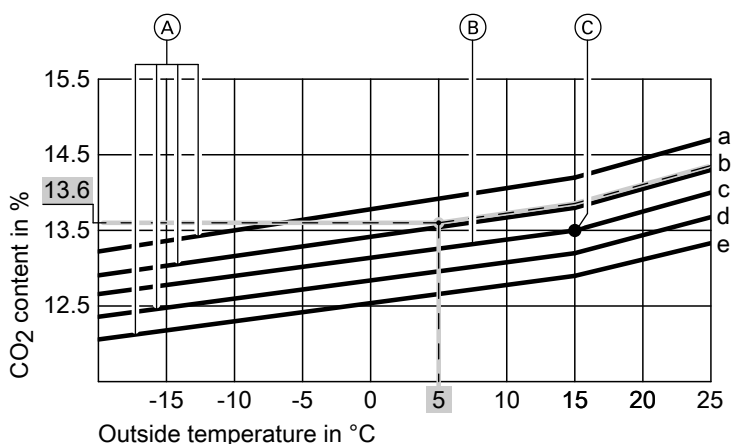

Fig. 16

- (A) Actual air pressure
- (B) Assumed average air pressure
- (C) Reference point outside temperature/CO₂ content

Assumptions relevant to the table:

- Length of the ventilation air pipe (Ø 80 mm) in the building: 5 m
- Boiler room temperature: 18 to 22 °C

Air pressure at geodetic height	m	up to 300	up to 600	up to 1000
a	mbar	940	905	860
b	mbar	960	925	880

Air pressure at geodetic height	m	up to 300	up to 600	up to 1000
c	mbar	980	945	900
d	mbar	1000	965	920
e	mbar	1020	985	940

Standard values for burner adjustment

Standard values for burner adjustment (cont.)

Example: Geodetic height 600 m above sea level
 Outside temperature 5 °C
 Air pressure 925 mbar

Result: Adjust CO₂ content to 13.6 %.

Rated heating output	kW	18	22	27	33
Oil burner nozzle					
Make: Danfoss ²	Type		80° S-LE		
	Gph	0.4	0.5	0.5	0.6
Oil pressure approx. ^{*3}	bar	14.0-17.0	12.5-15.5	18.0-25.0	16.0-19.0
Oil throughput	kg/h	1.7	2.0	2.5	2.9
	l/h	2.0	2.4	2.9	3.4
Air damper setting		9.0	6.5	15.5	10.0
Inlet air aperture position		8.0			
Static burner pressure ^{*4}	mbar	13.0	10.0	11.0	12.0

^{*2} The requirements for the eco-label were verified only with the nozzles specified.

^{*3} Due to nozzle tolerances and varying oil quality, the oil pressure may vary from the values shown.

^{*4} For checking the burner settings.

Report			Commissioning	Maintenance/service
Settings and test values	actual	<i>bar</i>		
	set	<i>bar</i>		
Oil pressure	actual	<i>bar</i>		
	after maintenance	<i>bar</i>		
Vacuum	actual	<i>bar</i>		
	after maintenance	<i>bar</i>		
Soot value	actual			
	after maintenance			
Carbon dioxide content CO₂	actual	<i>% by vol.</i>		
	set	<i>% by vol.</i>		
Carbon monoxide content CO	actual	<i>ppm</i>		
	set	<i>ppm</i>		
Oxygen content O₂	actual	<i>% by vol.</i>		
	set	<i>% by vol.</i>		
Flue gas temperature (gross)	actual	<i>°C</i>		
	set	<i>°C</i>		
Flue gas loss	actual	<i>%</i>		
	set	<i>%</i>		
Draught	actual	<i>hPa</i>		
	set	<i>hPa</i>		
Distance between nozzles (external)	actual	<i>mm</i>		
	set	<i>mm</i>		
Air damper setting	actual			
	set			

Specification

Specification

Rated boiler heating output	kW	18	22	27	33
Burner type		VHG I-2	VHG I-3	VHG I-4	VHG I-5
DIN reg. no. to EN 267		5G999/S			
Voltage	V	230			
Frequency	Hz	50			
Power consumption includes 4 ignition processes per hour	W	220	220	235	250
Motor speed	rpm	2800			
Version		Single stage			
Oil pump rate	l/h	45			
Connections Suction and return line on the supplied oil hoses	Rp	$\frac{3}{8}$			

Final decommissioning and disposal

Viessmann products can be recycled. Components and substances from the system are not part of ordinary household waste.

For decommissioning the system, isolate the system from the power supply and allow components to cool down where appropriate.

All components must be disposed of correctly.

Keyword index

A		I	
Adjusting the air volume.....	8	Inlet air aperture, setting.....	8
Adjusting the oil pressure and checking the vacuum... 8		Inlet air aperture position.....	26
Air damper setting.....	26		
B		L	
Burner		LE nozzle shut-off function.....	9
– Adjusting.....	25	LE setting screw.....	9
– Cleaning.....	10		
Burner control unit		N	
– Burner fault flowchart.....	17	Nozzle replacement.....	11
– Function and fault indication by indicator light (LED).....	15	Nozzle spacing adjustment.....	11
– Program sequence during commissioning.....	14		
Burner fault flowchart.....	17	O	
Burner pressure, static.....	8, 26	Oil burner nozzle.....	26
		Oil pressure.....	26
		Oil pump pressure setting screw.....	9
		Oil throughput.....	26
C			
Checking and adjusting the mixing assembly.....	11	P	
Cleaning the oil pump filter and replacing it if required..	12	Position of inlet air aperture.....	26
Component overview.....	22		
Connection and wiring diagram.....	24	R	
		Report.....	27
D			
Diagnosis		S	
– Faults with flash code indication.....	18	Setting for inlet air aperture.....	8
– Faults without flash code indication.....	19	Standard values for burner adjustment.....	25
		Symbols.....	6
		System commissioning.....	8
F			
Flame monitoring.....	22		
Flash code.....	18		
Flowchart, burner faults.....	17		



Viessmann Werke GmbH & Co. KG
D-35107 Allendorf
Telephone: +49 6452 70-0
Fax: +49 6452 70-2780
www.viessmann.com



Viessmann Limited
Hortonwood 30, Telford
Shropshire, TF1 7YP, GB
Telephone: +44 1952 675000
Fax: +44 1952 675040
E-mail: info-uk@viessmann.com

5777267 Subject to technical modifications.