

Installation and service instructions for contractors

VIESSMANN

Vitodens 111-W

Type B1LD, 4.7 to 35.0 kW

Gas condensing storage combi boiler

Natural gas and LPG version

Gas Council Number: 47-819-43, 47-819-44

For applicability, see the last page



VITODENS 111-W



Safety instructions

Safety instructions



Please follow these safety instructions closely to prevent accidents and material losses.

Safety instructions explained



Danger

This symbol warns against the risk of injury.



Please note

This symbol warns against the risk of material losses and environmental pollution.

Note

Details identified by the word "Note" contain additional information.

Target group

These instructions are exclusively intended for qualified contractors.

- Work on gas installations may only be carried out by a registered gas fitter.
- Work on electrical equipment may only be carried out by a qualified electrician.
- The system must be commissioned by the system installer or a qualified person authorised by the installer.

Regulations to be observed

- National installation regulations
- Statutory regulations for the prevention of accidents
- Statutory regulations for environmental protection
- Codes of practice of the relevant trade associations
- All current safety regulations as defined by DIN, EN, DVGW, TRGI, TRF, VDE and all locally applicable standards
- Ⓐ ÖNORM, EN, ÖVGW G K directives, ÖVGW-TRF and ÖVE
- Ⓒ SEV, SUVA, SVGW, SVTI, SWKI, VKF and EKAS guideline 1942: LPG, part 2

Safety instructions for working on the system

Working on the system

- Where gas is used as the fuel, close the main gas shut-off valve and safeguard it against unintentional reopening.
- Isolate the system from the power supply, e.g. by removing the separate fuse or by means of a mains isolator, and check that it is no longer live.
- Safeguard the system against reconnection.
- Wear suitable personal protective equipment when carrying out any work.



Danger

Hot surfaces can cause burns.

- Before maintenance and service work, switch OFF the appliance and let it cool down.
- Never touch hot surfaces on the boiler, burner, flue system or pipework.



Please note

Electronic assemblies can be damaged by electrostatic discharge.

Prior to commencing work, touch earthed objects such as heating or water pipes to discharge static loads.

Repair work



Please note

Repairing components that fulfil a safety function can compromise the safe operation of the system.

Replace faulty components only with genuine Viessmann spare parts.

Safety instructions (cont.)**Auxiliary components, spare and wearing parts****Please note**

Spare and wearing parts that have not been tested together with the system can compromise its function. Installing non-authorized components and making non-approved modifications or conversions can compromise safety and may invalidate our warranty.

For replacements, use only original spare parts supplied or approved by Viessmann.

Safety instructions for operating the system**If you smell gas****Danger**

Escaping gas can lead to explosions which may result in serious injury.

- Do not smoke. Prevent naked flames and sparks. Never switch lights or electrical appliances on or off.
- Close the gas shut-off valve.
- Open windows and doors.
- Evacuate any people from the danger zone.
- Notify your gas or electricity supply utility from outside the building.
- Have the power supply to the building shut off from a safe place (outside the building).

If you smell flue gas**Danger**

Flue gas can lead to life threatening poisoning.

- Shut down the heating system.
- Ventilate the installation site.
- Close doors to living spaces to prevent flue gases from spreading.

What to do if water escapes from the appliance**Danger**

If water escapes from the appliance there is a risk of electrocution.

Switch OFF the heating system at the external isolator (e.g. fuse box, domestic distribution board).

**Danger**

If water escapes from the appliance there is a risk of scalding.

Never touch hot heating water.

Condensate**Danger**

Contact with condensate can be harmful to health.

Never let condensate touch your skin or eyes and do not swallow it.

Flue systems and combustion air

Ensure that flue systems are clear and cannot be sealed, for instance due to accumulation of condensate or other external causes.

Avoid continuous condensate disposal with a wind protector.

Ensure an adequate supply of combustion air.

Inform system users that subsequent modifications to the building characteristics are not permissible (e.g. cable/pipework routing, cladding or partitions).

**Danger**

Leaking or blocked flue systems, or an inadequate supply of combustion air can cause life threatening poisoning from carbon monoxide in the flue gas.

Ensure the flue system is in good working order. Vents for supplying combustion air must be non-sealable.

Extractors

Operating appliances that exhaust air to the outside (extractor hoods, extractors, air conditioning units, etc.) can create negative pressure. If the boiler is operated at the same time, this can lead to a reverse flow of flue gas.

**Danger**

The simultaneous operation of the boiler and appliances that exhausts air to the outside can result in life threatening poisoning due to a reverse flow of flue gas.

Fit an interlock circuit or take suitable steps to ensure an adequate supply of combustion air.

1. Information	Disposal of packaging	6
	Symbols	6
	Intended use	7
	Product information	7
	■ Vitodens 111-W, type B1LD	7
	Product description	7
	■ Connecting accessories	7
2. Installation information	Preparing for boiler installation	8
	■ Dimensions and connections	8
	■ Preparing the connections	8
3. Installation sequence	Fitting the wall mounting bracket	10
	Mounting the boiler and making connections	11
	■ Removing the front panel and mounting the boiler	11
	■ Fitting the connections on the water side	11
	■ Gas connection	13
	■ Condensate drain connection	13
	■ Filling the trap with water	13
	■ Balanced flue connection	14
	Opening the control unit enclosure	15
	Electrical connections	15
	■ Connecting accessories	16
	■ Power supply	16
	■ Routing cables/leads and closing the control unit enclosure	17
4. Commissioning, inspection, maintenance	Steps - commissioning, inspection and maintenance	18
5. Changing the gas type	Changing from operation with LPG to operation with natural gas	39
6. Troubleshooting	Function sequence and possible faults	40
	Fault display	40
	Repairs	43
	■ Removing the front panel	43
	■ Outside temperature sensor	44
	■ Boiler water temperature sensor	45
	■ Checking the cylinder temperature sensor	46
	■ Checking the outlet temperature sensor	46
	■ Checking the temperature limiter	47
	■ Checking the flue gas temperature sensor	48
	■ Checking and cleaning the plate heat exchanger	48
	■ Checking the fuse	49
7. Parts lists	Overview of assemblies	51
	Casing assembly	52
	Heat cell assembly	54
	Burner assembly	56
	Hydraulic assembly	58
	Aqua-plate assembly	60
	Control unit assembly	62
	Cylinder module assembly	64
	Cylinder assembly	66
	Miscellaneous assembly	68
8. Control unit	Functions and operating conditions in weather-compensated mode	70
	■ Heating mode	70
	■ DHW heating	70

Index (cont.)

9. Connection and wiring diagram	72
10. Reports	73
11. Specification	74
12. Disposal	Final decommissioning and disposal	75
13. Certificates	Declaration of conformity	76
	■ Manufacturer's declaration	76
14. Keyword index	77

Disposal of packaging









Please dispose of packaging waste in line with statutory regulations.

DE: Use the disposal system organised by Viessmann.







AT: Use the ARA statutory disposal system (Altstoff Recycling Austria AG, licence number 5766).

CH: Packaging waste is disposed of by the HVAC contractor.

Symbols

Symbol	Meaning
	Reference to other document containing further information
	Step in a diagram: The numbers correspond to the order in which the steps are carried out.
	Warning of material losses and environmental pollution
	Live electrical area
	Pay particular attention.
	<ul style="list-style-type: none"> ▪ Component must audibly click into place. or ▪ Acoustic signal
	<ul style="list-style-type: none"> ▪ Fit new component. or ▪ In conjunction with a tool: Clean the surface.
	Dispose of component correctly.
	Dispose of component at a suitable collection point. Do not dispose of component in domestic waste.

The steps in connection with commissioning, inspection and maintenance are found in the "Commissioning, inspection and maintenance" section and identified as follows:

Symbol	Meaning
	Steps required during commissioning
	Not required during commissioning
	Steps required during inspection
	Not required during inspection
	Steps required during maintenance
	Not required during maintenance

Intended use

The appliance is intended solely for installation and operation in sealed unvented heating systems that comply with EN 12828, with due attention paid to the associated installation, service and operating instructions. It is only designed for heating up heating water that is of potable water quality.

Intended use presupposes that a fixed installation in conjunction with permissible, system-specific components has been carried out.

Commercial or industrial usage for a purpose other than heating the building or DHW shall be deemed inappropriate.

Any usage beyond this must be approved by the manufacturer in each individual case.

Incorrect usage or operation of the appliance (e.g. the appliance being opened by the system user) is prohibited and will result in an exclusion of liability. Incorrect usage also occurs if the components in the heating system are modified from their intended use (e.g. if the flue gas and ventilation air paths are sealed).

Product information

Vitodens 111-W, type B1LD

Preset for operation with natural gas

The Vitodens 111-W may only be delivered to the countries specified on the type plate. For deliveries to other countries, approved contractors must arrange individual approval on their own initiative and in accordance with the law of the country in question. The type plate is located behind the front panel (see page 51).

Product description

The Vitodens 111-W is equipped with a cylinder and an integral plate heat exchanger as a cylinder loading system for DHW heating. For the connection of heating circuits and the DHW line, see page 11 onwards. In the delivered condition, the Vitodens 111-W is set up for operation with a constant boiler water temperature. By connecting an outside temperature sensor (accessories), the boiler can be operated in weather-compensated mode.

The appliance is equipped with a sealed unvented hydraulic system with 2 connections for the heating flow and return and 2 connections for DHW heating.

The following components are integrated into the hydraulic system:

- Circulation pump
- 3-way diverter valve
- Safety valve
- Heating water expansion vessel and DHW expansion vessel
- Cylinder and plate heat exchanger for DHW heating

Connecting accessories

Outside temperature sensor and time switch are connected with low voltage to the control unit.

Preparing for boiler installation

Dimensions and connections

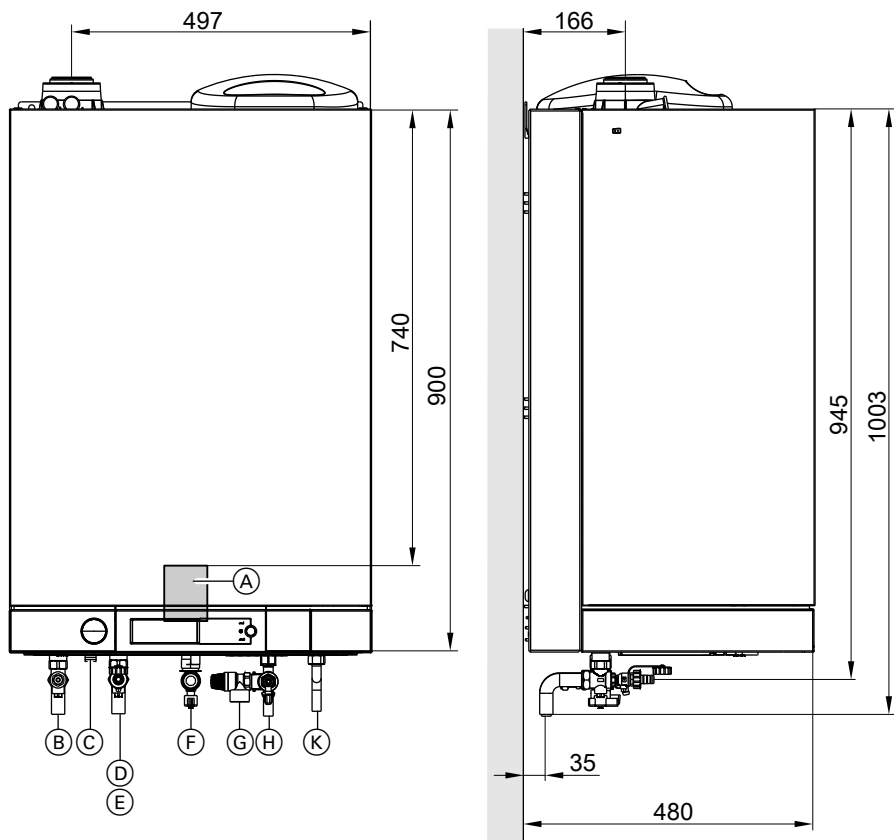

Fig. 1

- | | |
|--|--|
| (A) Area for electrical connections | (F) Gas connection \varnothing 22 mm |
| (B) Heating flow \varnothing 22 mm | (G) Safety valve (DHW side) |
| (C) Condensate drain | (H) Cold water \varnothing 15 mm |
| (D) Heating return \varnothing 22 mm | (K) DHW \varnothing 15 mm |
| (E) Filling/draining | |

Preparing the connections

Note

This boiler (IP rating: IP X4) is approved for installation in wet rooms inside safety zone 1 in accordance with IEEE Wiring Regulations, providing the occurrence of hosed water can be ruled out. Observe the IEEE Wiring Regulations.

1. Prepare the water connections. Flush the heating system.
2. Prepare the gas connection.
3. Prepare the electrical connections.
 - Power cable: A flexible cable 3 x 1.5 mm², approx. 1.5 m long is connected in the delivered condition.
 - Cables for accessories: 2-core sheathed cable min. 0.5 mm² for low voltage

Preparing for boiler installation (cont.)

Safety assembly to DIN 1988 and EN 806 at the cold water connection

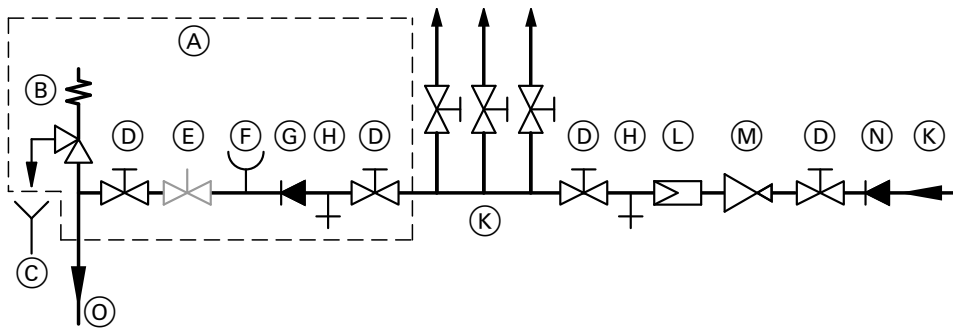

Fig. 2

- | | |
|--|---|
| (A) Safety assembly (accessories for connection sets for unfinished walls) | (H) Drain |
| (B) Safety valve | (K) Cold water |
| (C) Visible discharge pipe outlet point (tundish) | (L) Drinking water filter |
| (D) Shut-off valve | (M) Pressure reducer to DIN 1988-2, Dec. 1988 issue |
| (E) Flow regulating valve (installation recommended) | (N) Non-return valve/pipe separator |
| (F) Pressure gauge connection | (O) Cold water connection at connection set (accessories) |
| (G) Non-return valve | |

Combination inlet group

Combines elements (A), (M) and (N)

- Pressure reducing valve
This must be installed near the cylinder. The cold water supply to any mixer taps/showers must be taken from the cold water tapping of this valve to ensure balanced hot and cold pressures. This valve is factory set to ensure the correct operating pressure.
- Non-return valve
This is integral to the pressure-reducing valve to prevent the backflow of hot water towards cold water draw-off points.
- Cold water expansion relief valve
This safety device is preset at the factory and will relieve excess cold water pressure resulting from a fault condition.

Fitting the wall mounting bracket

Note

The installation surface must be vertical and level.

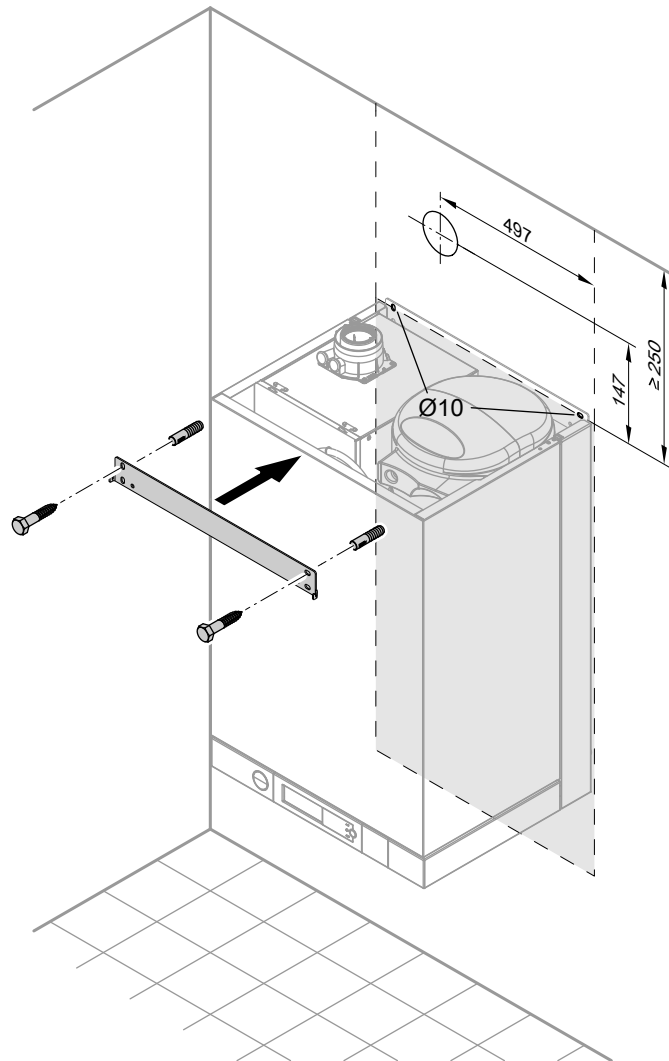

Fig. 3

1. Mark out the rawl plug holes.
2. Drill $\varnothing 10$ mm holes and insert the rawl plugs supplied.
3. Fit the wall mounting bracket with the screws supplied.

Note

The supplied rawl plugs are suitable for the following materials:

- Concrete
- Vertically perforated bricks
- Hollow concrete breeze blocks
- Hollow brick and concrete ceilings
- Perforated sand lime bricks
- Solid sand lime bricks
- Natural stone with dense structure
- Porous concrete
- Solid gypsum panels
- Solid concrete breeze blocks
- Solid bricks

Mounting the boiler and making connections

Removing the front panel and mounting the boiler

Note

When mounting on a wall, please note: Weight without packaging is approx. 65 kg.

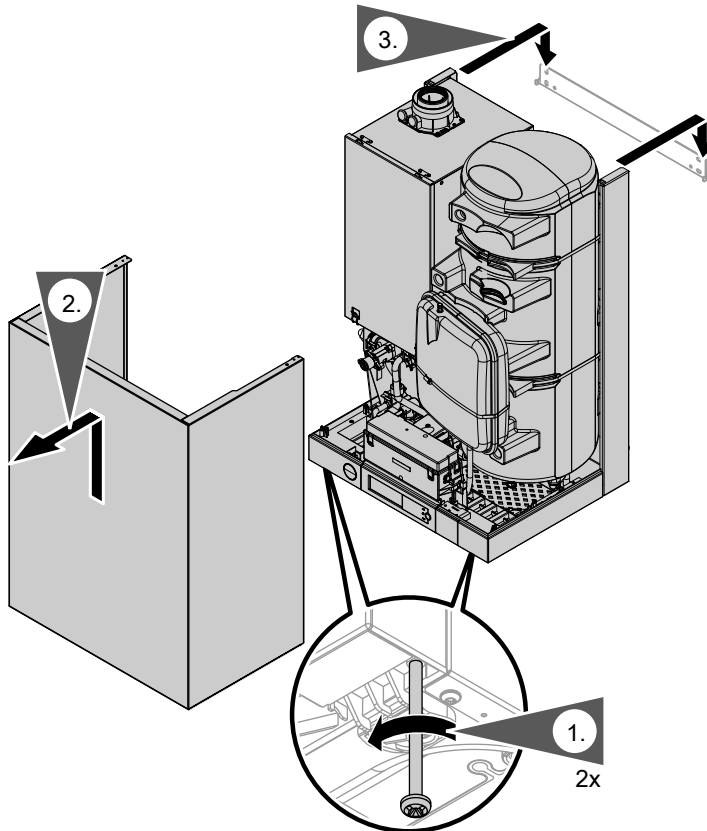

Fig. 4

1. Undo the screws on the underside of the boiler; do not remove them completely.
2. Remove front panel.
3. Hook the boiler into the wall mounting bracket.
4. Take the additional type plate from the documentation supplied with the boiler. In consultation with the system user, attach the additional type plate to the outside of the appliance in a position visible to the flue gas inspector.

Fitting the connections on the water side



For installation of fittings on the heating water side and DHW side, see separate installation instructions.



Please note

To prevent appliance damage, connect all pipework free of load and torque stress.

Mounting the boiler and making connections (cont.)

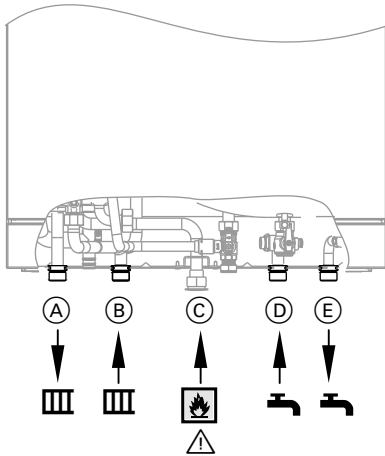

Fig. 5

- Ⓐ Heating flow
- Ⓑ Heating return
- Ⓒ Gas connection

- Ⓓ Cold water
- Ⓔ DHW
- Ⓕ Safety assembly

Connection on the DHW side

Permiss. operating pressure, cylinder: 10 bar.
 Install supplied safety assembly Ⓕ in the cold water connection.
 No flow limiter is fitted in the cold water supply.

Mounting the connection set

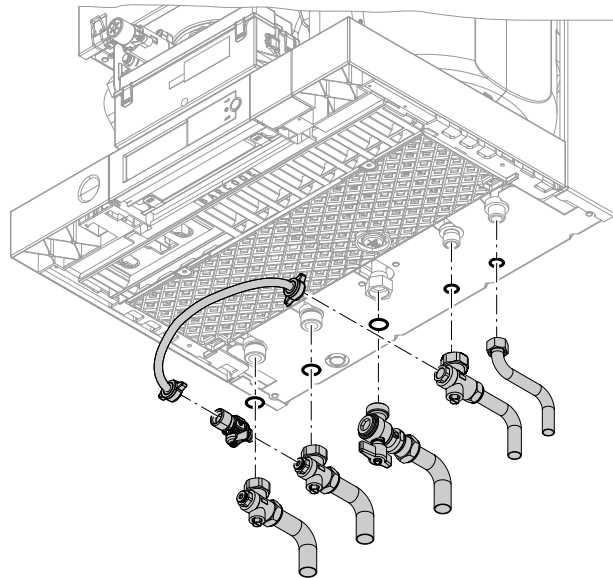

Fig. 6

Mounting the boiler and making connections (cont.)

Gas connection

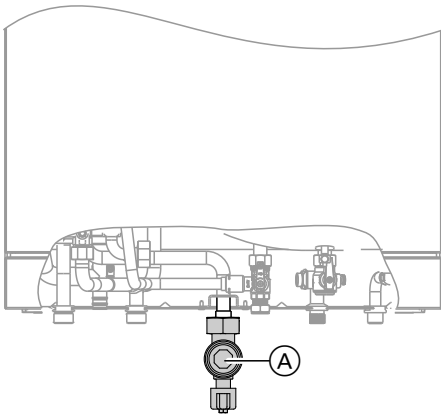

Fig. 7

1. Connect the gas shut-off valve to connection (A).
2. Carry out a tightness test.

Note

Only use suitable and approved leak detection agents (EN 14291) and devices for the tightness test. Leak detection agents with unsuitable constituents (e.g. nitrides, sulphides) can cause material damage.

Remove residues of the leak detection agent after testing.



Please note

Excessive test pressure will damage the boiler and the gas train.

Max. test pressure 150 mbar (15 kPa). If a higher pressure is required for tightness tests, disconnect the boiler and the gas train from the main supply pipe. Undo the fitting.

3. Purge the gas line.

Condensate drain connection

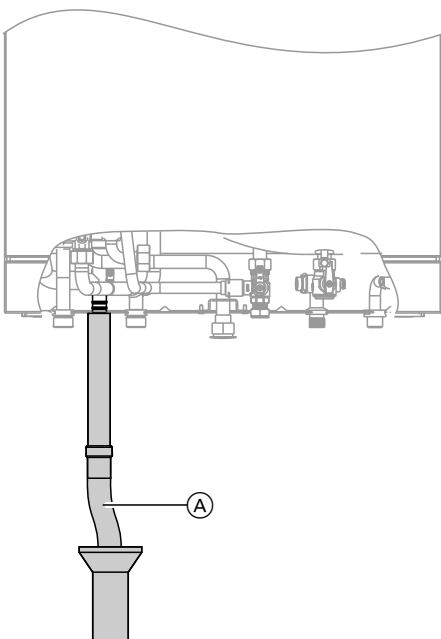

Fig. 8

- The condensate pipe is connected to the discharge pipe of the safety valve. The condensate hose supplied meets the temperature requirements that are part of the CE certification.
- We recommend connecting the condensate pipe internally to the domestic waste water system, either directly or via a tundish.
- If the condensate pipe is routed outside the building, use a pipe with min. \varnothing 30 mm and protect the pipe from frost. Avoid long external pipe runs.



Please note

A frozen condensate pipe can result in faults and damage to the boiler.

Always protect condensate pipes against frost.

- Observe local building regulations. Connect condensate pipe (A) to the public sewage system with a constant fall and a pipe vent. Observe local waste water regulations.

Note

Fill the trap with water before commissioning.

Filling the trap with water



Please note

During commissioning, flue gas may escape from the condensate drain.

Always fill the trap with water before commissioning.

Mounting the boiler and making connections (cont.)

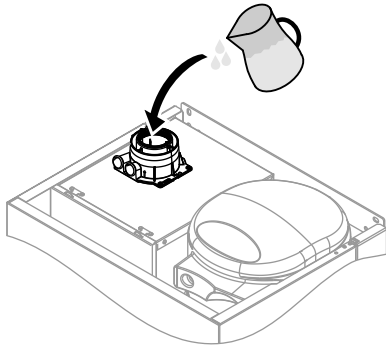

Fig. 9

Pour at least 0.3 l of water into the flue gas connection.

! Please note

- Water in the ventilation air supply can be detrimental to the combustion quality. Never pour water into the external ventilation air aperture.

Balanced flue connection

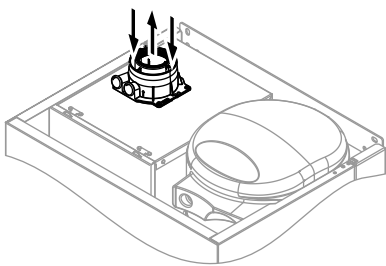



Fig. 10

Connect the balanced flue pipe. During installation and positioning of the flue system, observe Building Regulations Part L and BS 5440.

 Flue system installation instructions

Connecting several Vitodens 111-W to a shared flue system

Adjust the burner settings of each connected boiler to match the flue system:

- For shared connection, see page 26.

Note

The back draught safety device available as an accessory must be installed on every boiler.

Only carry out **commissioning** when the following conditions have been met:

- Unrestricted flow in the flue gas routes.
- Positive pressure flue system is gas-tight.
- Inspection port covers checked for secure and tight seating.
- Apertures for supplying sufficient combustion air are open and cannot be closed.
- All current regulations on installing and commissioning flue systems have been observed.



Danger

Leaking or blocked flue systems, or an inadequate supply of combustion air can cause life threatening poisoning from carbon monoxide in the flue gas.

Ensure the flue system is in good working order. Vents for supplying combustion air must be non-closable.

Opening the control unit enclosure

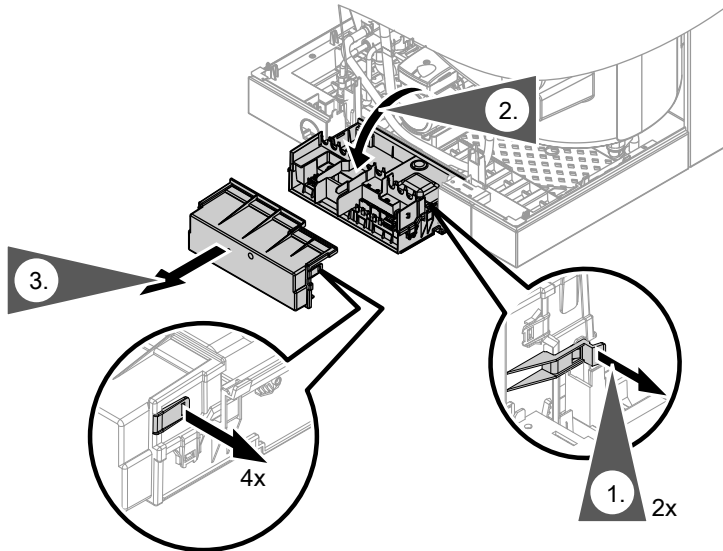

Fig. 11



Please note

Electronic assemblies can be damaged by electrostatic discharge. Prior to commencing any work, touch earthed objects such as heating or water pipes to discharge static loads.

Electrical connections



Information on connecting accessories

When connecting accessories observe the separate installation instructions provided with them.

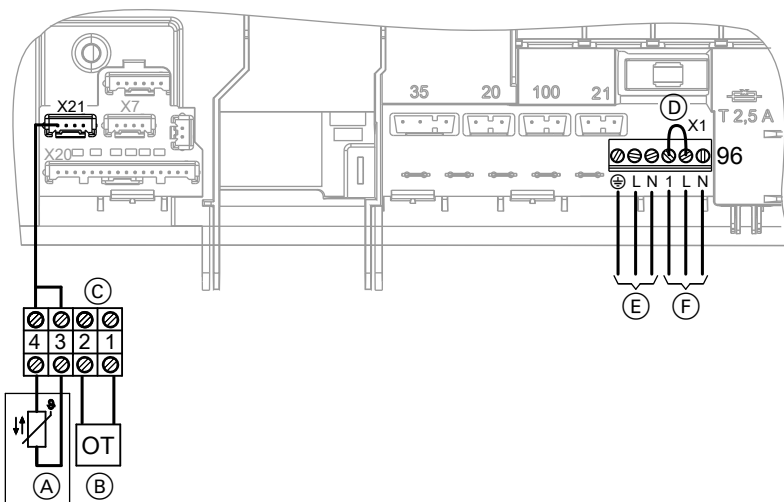

Fig. 12

- (A) Only for weather-compensated mode: Outside temperature sensor (accessories)
- (B) OpenTherm device
Remove jumper (D) when making this connection.
- (C) Connecting cable
- (D) Jumper
- (E) Power supply (230 V, 50 Hz)
See page 16.
- (F) Vitotrol 100 or on-site room temperature controller (230 V switched input)
Remove jumper (D) when making this connection.
Separate installation instructions

Connecting accessories



Accessory installation instructions

When connecting a Vitotrol 100 or an OpenTherm remote control, remove the jumper across L and 1.

Outside temperature sensor (accessories)

1. Fit the outside temperature sensor.

Installation location:

- North or north-westerly wall, 2 to 2.5 m above ground level. In multi storey buildings, in the upper half of the second floor.
- Not above windows, doors or vents
- Not immediately below balconies or gutters
- Never render over
- Connection:
2-core lead, length up to 35 m with a cross-section of 1.5 mm²

2. Connect the outside temperature sensor to the connecting cable across terminals 3 and 4 (see page 15).

Power supply

Regulations and directives



Danger

Incorrectly executed electrical installations can result in injuries from electrical current and damage to the appliance.

Connect the power supply and implement all safety measures (e.g. RCD circuit) in accordance with the following regulations:

- IEC 60364-4-41
- IEEE Wiring Regulations
- Connection requirements specified by your local power supply utility

Install an isolator in the power cable that simultaneously isolates all non-earthed conductors from the power supply with at least 3 mm contact separation.

We also recommend installing an AC/DC-sensitive RCD (RCD class B ) for DC (fault) currents that can occur with energy efficient equipment. Protect the power cable with an external 3 A fuse to BS 1362.



Danger

Incorrect core assignment can result in serious injury and damage to the appliance. Take care **not** to interchange wires "L1" and "N".



Danger

The absence of component earthing for the system can lead to serious injury from electric current if an electrical fault occurs. The appliance and pipework must be connected to the equipotential bonding of the building.

Electrical connections (cont.)**Routing cables/leads and closing the control unit enclosure**

- !** **Please note**
Connecting cables/leads will be damaged if they touch hot components.
When routing and securing cables/leads on site, ensure that the maximum permissible temperature for these is not exceeded.

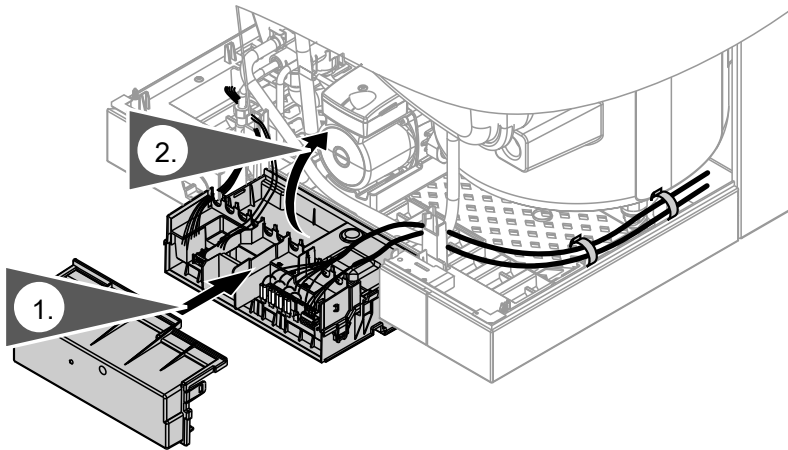

Fig. 13



Steps - commissioning, inspection and maintenance

			Page
•	•	•	1. Filling the heating system..... 19
•			2. Adjusting the pre-charge pressure of the diaphragm expansion vessel on the DHW side (if installed)..... 20
•			3. Filling the loading cylinder on the DHW side..... 21
•	•	•	4. Venting the boiler by flushing..... 21
•	•	•	5. Changing the gas type 22
•	•	•	6. Checking the static pressure and supply pressure..... 23
•			7. Reducing the maximum heating output..... 24
•			8. Matching the circulation pump rate to the heating system..... 25
•			9. Matching the burner output to the flue system..... 26
•			10. Burner adjustment when connecting multiple flues to a shared flue system..... 26
•			11. Checking the combustion quality..... 30
•	•	•	12. Removing the burner 32
•	•	•	13. Checking the burner gasket and burner gauze assembly..... 33
•	•	•	14. Checking and adjusting the electrode..... 33
•	•	•	15. Cleaning the heat exchanger..... 34
•	•	•	16. Checking the condensate drain and cleaning the trap..... 35
•	•	•	17. Installing the burner 35
•	•	•	18. Checking the diaphragm expansion vessels and system pressure..... 36
•	•	•	19. Checking the safety valve function
•	•	•	20. Checking all connections on the heating water and DHW sides for leaks
•	•	•	21. Checking the flue system for unrestricted flow and tightness
•	•	•	22. Checking the firm seating of electrical connections
•	•	•	23. Checking all gas equipment for tightness at operating pressure 37
•	•	•	24. Fitting the front panel..... 37
•			25. Setting display backlighting for standby..... 37
•			26. Setting the display contrast..... 38
•			27. Setting the signal tone for display operation..... 38
•			28. Instructing the system user..... 38



Filling the heating system

According to EN 1717, as a heat transfer medium for DHW heating, the heating water must meet fluid category ≤ 3 . This requirement is met if water of potable quality is used as heating water. For example, if additives are used, the additive manufacturer must specify which category the treated heating water comes under.



Please note

- Unsuitable fill water increases the level of deposits and corrosion and may lead to appliance damage.
 - Flush the heating system thoroughly before filling.
 - Only fill with water of potable quality.
 - Fill water with a hardness above 300 ppm must be softened.
 - Special antifreeze suitable for heating systems can be added to the fill water. The antifreeze manufacturer must verify its suitability.

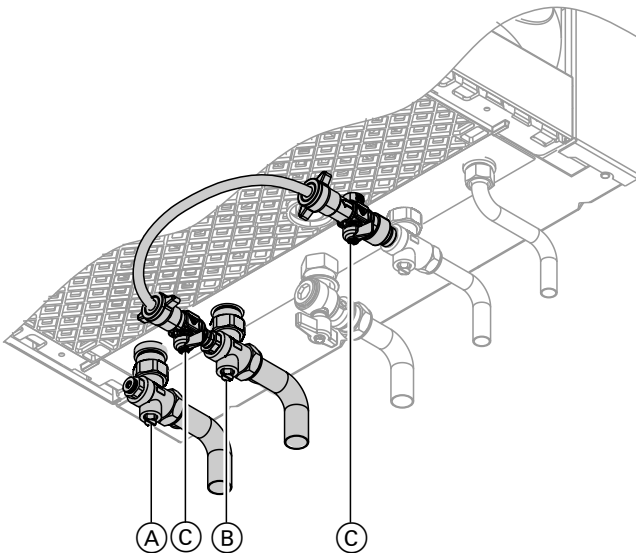

Fig. 14

1. Close the gas shut-off valve.
2. Switch ON the power supply.

Information on automatic testing of the flue gas temperature sensor

The control unit automatically checks the function of the flue gas temperature sensor as soon as the power supply is switched on.

Whilst this happens, the internal circulation pump is briefly switched off.

During the test, also switch off **all** external circulation pumps in the system.

If the flue gas temperature sensor is positioned incorrectly, commissioning is cancelled and fault message A3 is displayed (see "Repairs").

3. Tap **MODE**.
 4. ▲/▼ repeatedly until **CONF** flashes.
 5. **OK** to confirm.
"P" is displayed in the l.h. display area. The r.h. display area flashes.
 6. Use ▲/▼ to select "12".
 7. **OK** to confirm.
"1" flashes in the l.h. display area.
 8. **OK** to confirm.
"0" flashes in the r.h. display area.
 9. Use ▲/▼ to select "1".
 10. **OK** to confirm.
Filling is activated. The boiler circuit pump is running; the 3-way diverter valve moves to its centre position. This function terminates automatically after 30 min or when the ON/OFF switch is turned off.
 11. Open shut-off valves (A) and (if fitted) (B).
 12. Open valves (C) and fill the heating system. Minimum system pressure > 0.8 bar (80 kPa).
- Note**
Ensure that the safety valve does not respond when you are filling the system. If the flow rate through the safety valve becomes too high, water may enter the combustion chamber.
13. Close valves (C).
 14. Remove connection line between the two valves (C). During operation, the connection **must** be interrupted.



Adjusting the pre-charge pressure of the diaphragm expansion vessel on the DHW side (if installed)

Adjust the pre-charge pressure of the DHW-side diaphragm expansion vessel (accessories) in accordance with the system pressure on the DHW side:

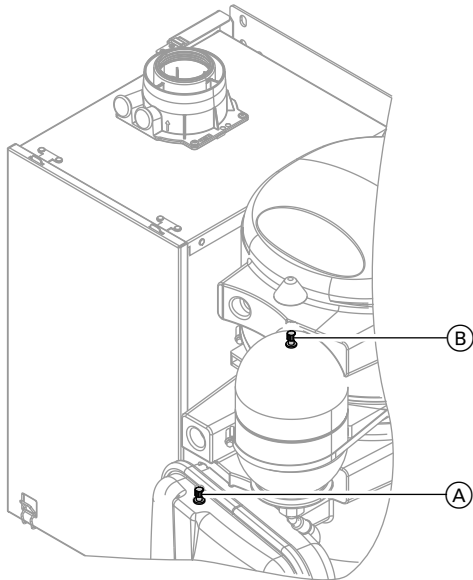

Fig. 15

- (A) Test connector, heating water expansion vessel
- (B) Test connector, DHW expansion vessel (if installed)

DHW-side system pressure (bar)	Response pressure, safety valve (bar)		
	6	8	10
	Pre-charge pressure of DHW-side diaphragm expansion vessel (bar)		
2.5	–	2.3	2.3
3.0	–	2.8	2.8
3.5	–	–	3.3

Specification for DHW-side diaphragm expansion vessel (accessories):

- Pre-charge pressure factory setting 5.2 bar
- Max. operating pressure 10 bar
- Max. DHW temperature 65 °C



Filling the loading cylinder on the DHW side

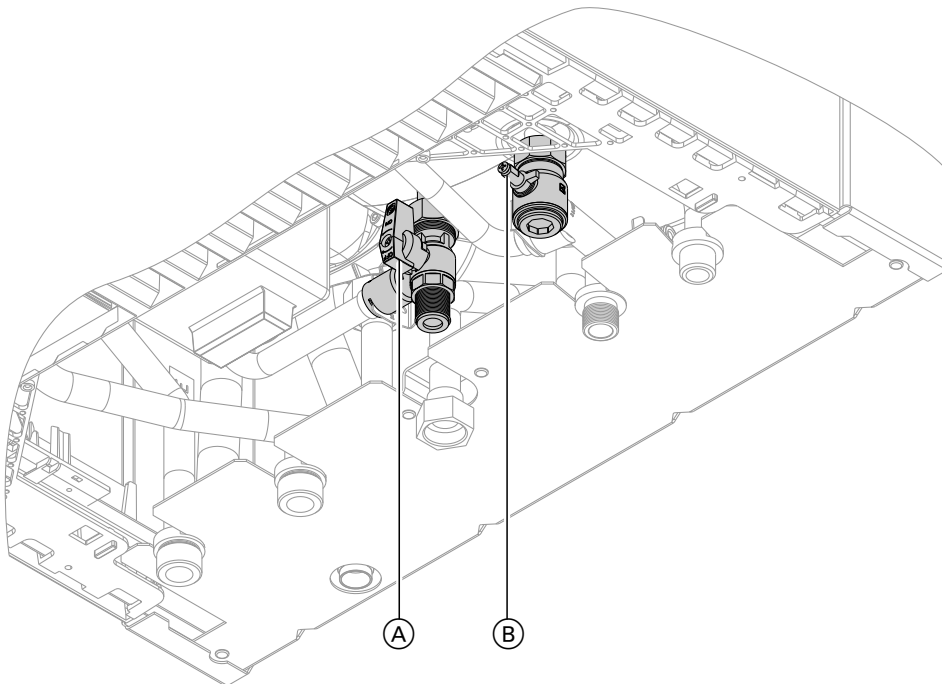

Fig. 16

1. Valves (A) and (B) must be in the "top" position.
2. Open the cold water supply and a DHW draw-off point.
3. Once air stops coming out of the DHW draw-off point, the loading cylinder is completely filled.



Venting the boiler by flushing

Note

Inadequate venting can result in damage due to steam blasts in the heat exchanger.

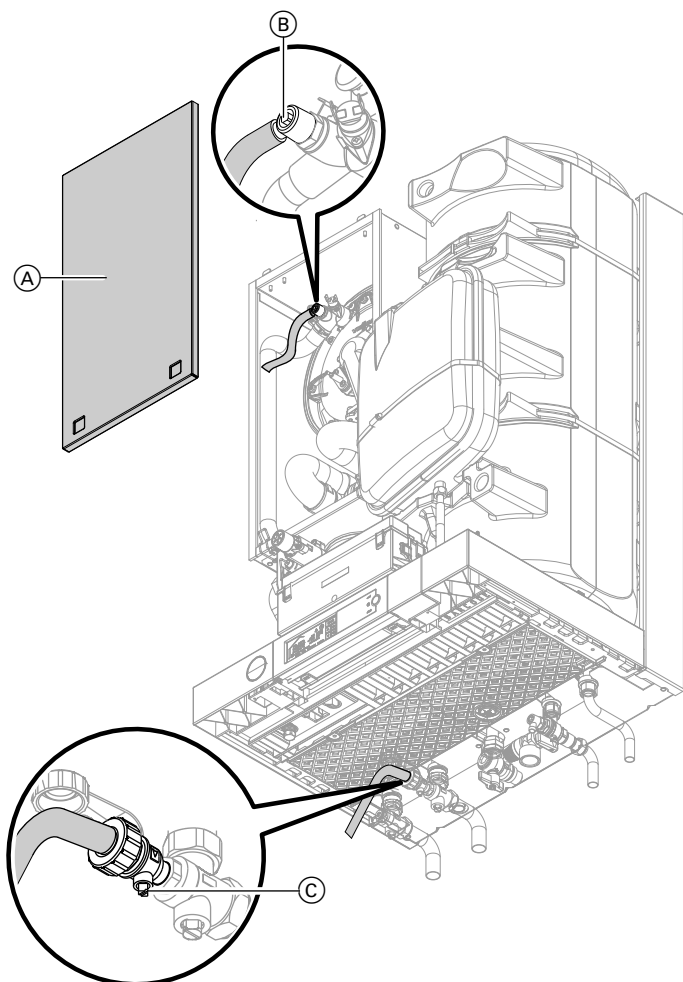

Fig. 17

1. Close the shut-off valves on the heating water side.
2. Remove cover panel (A).
3. Connect the drain hose fitted at top valve (B) to a drain connection.
4. Open fill valve (C) and air vent valve (B) and vent at mains pressure until no sound of escaping air can be heard.
5. First close valve (B).
6. When the required operating pressure has built up, close valve (C). Minimum system pressure 0.8 bar (80 kPa)
Open the shut-off valves on the heating water side.
7. Remove the drain hose again from top valve (B) and retain outside the boiler.

Note

Check the system pressure at the pressure gauge.
Never exceed 1.5 bar (150 kPa).

   **Changing the gas type**

In the delivered condition, the boiler is set up for operation with natural gas (G 20).
For operation with a different gas type, install a conversion kit and change the gas type at the control unit.

Enter the selected gas type and the associated limits for flue gas emissions in the table below.

 For values, see separate installation instructions.

 Separate installation instructions



Changing the gas type (cont.)

Selected gas type

	Gas type	Date	CO ₂ content in %	O ₂ content in %	CO content in ppm
Delivered condition	G 20		7.5 - 10.5		< 1000
Changed to					< 1000
Changed to					< 1000



Checking the static pressure and supply pressure



Danger

CO formation as a result of incorrect burner adjustment can have serious health implications. Check the CO content before and after carrying out work on gas appliances.

Operation with LPG

Purge the LPG tank twice on commissioning or replacement. Vent the tank and gas connection line thoroughly after purging.

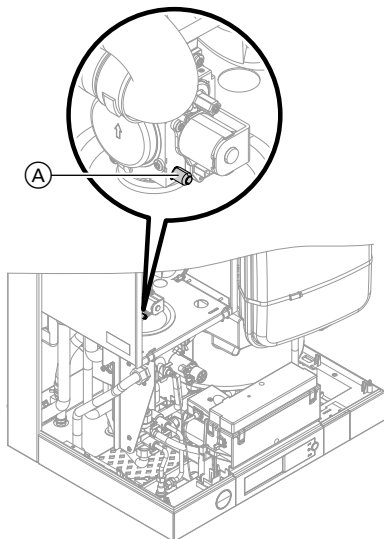

Fig. 18

1. Close the gas shut-off valve.
2. Undo screw (A) inside test connector "IN" on the gas train, but do not remove it. Connect the pressure gauge.
3. Open the gas shut-off valve.
4. Check the static pressure.
Set value: max. 57.5 mbar (5.75 kPa)

5. Start the boiler.

Note

During commissioning, the appliance can enter a fault state because of airlocks in the gas line. After approx. 5 s, tap and hold "R" for approx. 2 s to reset the burner.

Ensure that enough heat is being drawn during the testing and setting processes.

6. Check the supply (flow) pressure.

Set value:

- Natural gas: 20 mbar (2.0 kPa)
- LPG: 50 mbar (5.0 kPa)

Note

Use a suitable tester with a resolution of at least 0.1 mbar (10 Pa) to check the supply pressure.

7. Implement measures as indicated in the table below.
8. Shut down the boiler and close the gas shut-off valve. Remove the pressure gauge and seal test connector (A) with screw.
9. Open the gas shut-off valve and start the appliance.



Danger

Gas escaping from the test connector leads to a risk of explosion.

Check gas tightness at test connector (A).

Note

The maximum pressure drop between the gas shut-off valve and test connector (A) at the gas train is 0.5 mbar (50 Pa).



Checking the static pressure and supply pressure (cont.)

Supply pressure (flow pressure)		Steps
For natural gas	For LPG	
Below 10 mbar (1.0 kPa)	Below 25 mbar (2.5 kPa)	Do not commission the boiler. Notify the gas supply utility or LPG supplier.
10 to 33 mbar (1.0 to 3.3 kPa)	25 to 57.5 mbar (2.5 to 5.75 kPa)	Start the boiler.
Above 33 mbar (3.3 kPa)	Above 57.5 mbar (5.75 kPa)	Connect a separate gas pressure governor upstream of the system and set it to the nominal pressure (see type plate). Notify the gas supply utility or LPG supplier.



Reducing the maximum heating output

The maximum heating output can be reduced according to the system requirements.

1. Tap **MODE**.
 2. ▲/▼ until **CONF1** flashes.
 3. **OK** to confirm
"P" is displayed in the l.h. display area. The r.h. display area flashes.
 4. Use ▲/▼ to select "12".
 5. **OK** to confirm
"1" flashes in the l.h. display area.
 6. Use ▲/▼ to select "2".
 7. **OK** to confirm
The value of the selected maximum heating output, in % of the upper heating output, flashes in the r.h. display area.
 8. Use ▲/▼ to select the required max. heating output. See the following table.
- Note**
The figures relate to natural gas G 20. Balanced flue pipe Ø 60/100 mm, 1 m long.
9. **OK** to confirm. The selected value is adopted.
 10. Check the selected heating output by measuring the gas throughput.

Heating output in kW	Setting in %	
	Rated heating output in kW	
	26	35
35	—	90
34	—	87
33	—	85
32	—	82
31	—	80
30	—	77
29	—	74
28	—	72
27	—	69
26	80	67
25	77	64
24	74	62
23	71	59
22	68	56
21	65	54
20	61	51
19	58	49
18	55	46
17	52	44
16	49	41
15	46	38
14	43	36
13	40	33
12	37	31
11	34	28
10	31	26
9	28	23
8	25	20
7	22	18



Reducing the maximum heating output (cont.)

Heating output in kW	Setting in %	
	Rated heating output in kW	
	26	35
6	19	15
5	15	—



Matching the circulation pump rate to the heating system

In its delivered condition the circulation pump rate is set to the following values:

- For DHW heating: speed 100 %
- For heating mode without outside temperature sensor:

Rated heating output in kW	26	35
Speed in %	90	100

The speed cannot be changed.

- For heating mode with outside temperature sensor:

Rated heating output in kW	26	35
Min. speed in %	65	65
Max. speed in %	90	100

The maximum speed can be changed. See the following chapter.

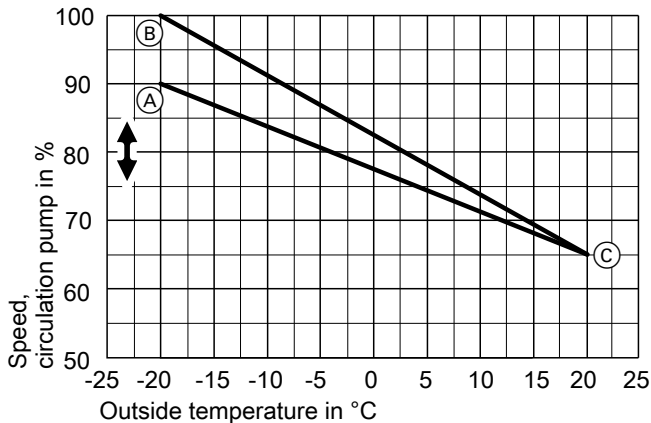

Fig. 19

- (A) Max. speed 26 kW
- (B) Max. speed 35 kW
- (C) Min. speed

Changing the maximum speed

Only when operating with an outside temperature sensor.

1. Tap **MODE**.
2. ▲/▼ repeatedly until **CONF1** flashes.
3. **OK** to confirm.
"P" is displayed in the l.h. display area. The r.h. display area flashes.
4. Use ▲/▼ to select "12".
5. **OK** to confirm.
"1" flashes in the l.h. display area.
6. Use ▲/▼ to select "6".
7. **OK** to confirm.
The selected max. speed in % will flash in the r.h. display area.
8. Use ▲/▼ to change the speed value.
Max. speed and setting range are subject to appliance-specific parameters.
9. **OK** to confirm. The selected value is adopted.



Matching the burner output to the flue system

To match the burner output to the system flue pipe length, a correction factor can be set.

1. Tap **MODE**.
2. ▲/▼ repeatedly until **CONF1** flashes.
3. **OK** to confirm.
"P" is displayed in the l.h. display area. The r.h. display area flashes.
4. Use ▲/▼ to select "12".
5. **OK** to confirm.
"1" flashes in the l.h. display area.
6. Use ▲/▼ to select "3".
7. **OK** to confirm.
The selected correction factor flashes in the r.h. display area.
8. Refer to the following table for the correction factor required for the connected flue system.
9. Use ▲/▼ to change the correction factor.
10. **OK** to confirm. The selected value is adopted.

Correction factor		0	1	2	3	4	5	6
Flue system	Rated heating output (kW)	Max. pipe length (m)						
Open flue operation Ø 60 mm	26	3	12	15	—	—	—	—
	35	4	9	15	22	25	—	—
Room sealed operation Ø 60/100 mm coaxial	26	2	6	11	16	20	—	—
	35	2	5	8	12	16	25	—
Open flue operation Ø 80 mm	26	16	25	—	—	—	—	—
	35	11	25	—	—	—	—	—
Room sealed operation Ø 80/125 mm coaxial	26	5	20	25	—	—	—	—
	35	5	13	22	25	—	—	—



Burner adjustment when connecting multiple flues to a shared flue system

When connecting several Vitodens 111-W to a shared flue system:

Adjust the burner settings of each connected boiler by a correction factor to match it to the flue system.

System conditions:

- Shared flue in shaft Ø 100 mm
- Balanced flue connection pipe from boiler to shaft, Ø 80/125 mm

- Minimum shaft cross-section
 - Square: 175 x 175 mm
 - Round: Ø 195 mm
- Height between floors min. 2.5 m
- Max. 6 boilers with the same rated heating output connected to the flue system

1. Tap **MODE**.
2. ▲/▼ until **CONF1** flashes.
3. **OK** to confirm.
"P" appears in the l.h. display area. The r.h. display area flashes.
4. Use ▲/▼ to select "12".
5. **OK** to confirm.
"1" flashes in the l.h. display area.
6. Use ▲/▼ to select "4".
7. **OK** to confirm.
"0" flashes in the r.h. display area.
8. Refer to the following tables for the correction factor required for the flue system.
9. Use ▲/▼ to set the correction factor.
10. **OK** to confirm. The selected value is adopted.



Burner adjustment when connecting multiple... (cont.)

One boiler per floor

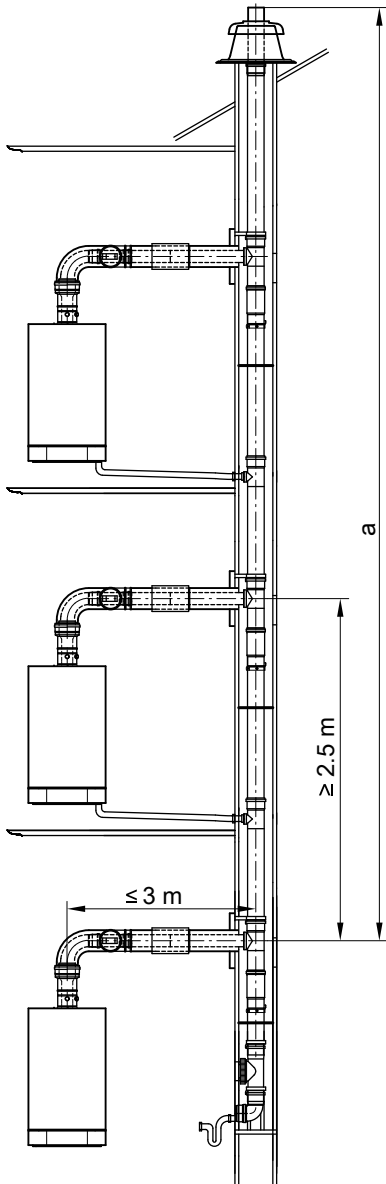

Fig. 20

Rated heating output 26 kW – operation with natural gas

Number of boilers	2	3	4	5	6
Correction factor (adjustable value)	Flue length a (m)				
0					
1	≤ 18	≤ 9			
2	> 18 ≤ 25	> 9 ≤ 21	≤ 13	≤ 12	
3	–	> 21 ≤ 25	> 13 ≤ 23	> 12 ≤ 18	≤ 16
4	–	–	> 23 ≤ 25	> 18 ≤ 25	> 16 ≤ 21
5	–	–	–	–	> 21 ≤ 25
6	–	–	–	–	–

Rated heating output 26 kW – operation with LPG

Number of boilers	2	3	4	5	6
Correction factor (adjustable value)	Flue length a (m)				
0					
1	≤ 25	≤ 12	≤ 10		
2	–	> 12 ≤ 25	> 10 ≤ 16	≤ 13	
3	–	–	> 16 ≤ 23	> 13 ≤ 17	≤ 15
4	–	–	> 23 ≤ 25	> 17 ≤ 22	> 15 ≤ 18
5	–	–	–	> 22 ≤ 25	> 18 ≤ 22
6	–	–	–	–	> 22 ≤ 25

Rated heating output 35 kW – operation with natural gas

Number of boilers	2	3	4	5	6
Correction factor (adjustable value)	Flue length a (m)				
0					
1	≤ 19	≤ 9			
2	> 19 ≤ 25	> 9 ≤ 21	≤ 13	≤ 12	
3	–	> 21 ≤ 25	> 13 ≤ 18	> 12 ≤ 15	≤ 14
4	–	–	> 18 ≤ 25	> 15 ≤ 18	> 14 ≤ 16
5	–	–	–	> 18 ≤ 24	> 16 ≤ 20
6	–	–	–	> 24 ≤ 25	> 20 ≤ 23

Rated heating output 35 kW – operation with LPG

Number of boilers	2	3	4	5	6
Correction factor (adjustable value)	Flue length a (m)				
0					
1	≤ 22	≤ 10			
2	> 22 ≤ 25	> 10 ≤ 20	≤ 13	≤ 12	
3	–	> 20 ≤ 25	> 13 ≤ 17	> 12 ≤ 14	
4	–	–	> 17 ≤ 23	> 14 ≤ 18	≤ 16
5	–	–	> 23 ≤ 25	> 18 ≤ 21	> 16 ≤ 18
6	–	–	–	> 21 ≤ 24	> 18 ≤ 20

Note

The correction factor changes the boiler modulation range.



Two boilers per floor

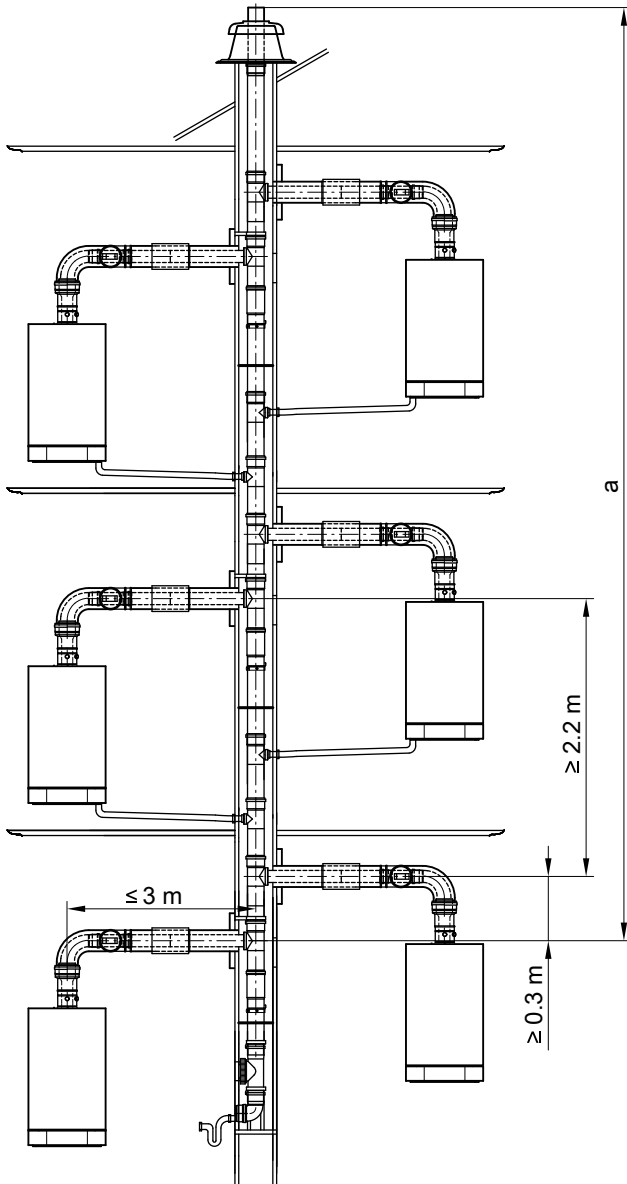

Fig. 21

Rated heating output 26 kW – operation with natural gas

Number of boilers	2	4	6
Correction factor (adjustable value)	Flue length a (m)		
0			
1	≤ 16	≤ 4	
2	> 16 ≤ 25	> 4 ≤ 10	≤ 7
3	–	> 10 ≤ 20	> 7 ≤ 11
4	–	> 20 ≤ 25	> 11 ≤ 15
5	–	–	> 15 ≤ 20
6	–	–	> 20 ≤ 24

Burner adjustment when connecting multiple... (cont.)
Rated heating output 26 kW – operation with LPG

Number of boilers	2	4	6
Correction factor (adjustable value)	Flue length a (m)		
0			
1	≤ 25	≤ 6	
2	–	> 6 ≤ 12	≤ 8
3	–	> 12 ≤ 19	> 8 ≤ 10
4	–	> 19 ≤ 25	> 10 ≤ 13
5	–	–	> 13 ≤ 16
6	–	–	> 16 ≤ 20

Rated heating output 35 kW – operation with natural gas

Number of boilers	2	4	6
Correction factor (adjustable value)	Flue length a (m)		
0			
1	≤ 17	≤ 4	
2	> 17 ≤ 25	> 4 ≤ 10	≤ 7
3	–	> 10 ≤ 15	> 7 ≤ 8
4	–	> 15 ≤ 21	> 8 ≤ 11
5	–	> 21 ≤ 25	> 11 ≤ 15
6	–	–	> 15 ≤ 17

Rated heating output 35 kW – operation with LPG

Number of boilers	2	4	6
Correction factor (adjustable value)	Flue length a (m)		
0			
1	≤ 20	≤ 5	
2	> 20 ≤ 25	> 5 ≤ 9	≤ 6
3	–	> 9 ≤ 14	> 6 ≤ 8
4	–	> 14 ≤ 20	> 8 ≤ 10
5	–	> 20 ≤ 25	> 10 ≤ 13
6	–	–	> 13 ≤ 15

Note

The correction factor changes the boiler modulation range.

Checking the combustion quality

The Vitodens 111-W is factory-set for natural gas. During commissioning or maintenance, the CO₂ and CO have to be measured at the boiler flue adaptor test port to check the flue integrity. Subject to the Wobbe index, the CO₂ content fluctuates between 7.5 % and 10.5 %. CO of up to 500 ppm during start-up is acceptable. We recommend measuring the O₂, as this value is unmistakable regarding lambda (air/gas). The O₂ content fluctuates between 7.5 % and 3.2 %. The CO/CO₂ ratio has to be less than 0.004.

If the actual CO₂ or O₂ and CO values deviate from the stated range, check the balanced flue system for leaks. If the flue installation is OK, change the gas valve.

Note

To prevent operating faults and damage, operate the appliance with uncontaminated combustion air.



Checking the combustion quality (cont.)

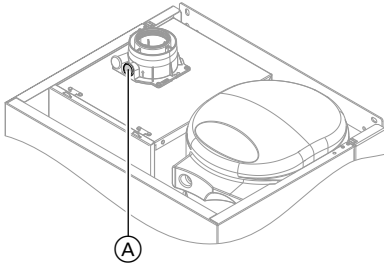

Fig. 22

1. Connect a flue gas analyser at flue gas port (A) on the boiler flue connection.
2. Start the boiler and check for leaks.

Danger
Escaping gas leads to a risk of explosion. Check all gas equipment for tightness.

3. To check the CO₂ content the burner output can be adjusted manually.
 1. Tap **MODE**.
 2. ▲/▼ repeatedly until "**SERV**" appears.
 3. **OK** to confirm. **OFF** appears on the display. Test mode is not active.
 4. Use ▲/▼ to adjust the burner output:

Shown on display	burner output	
	OFF	0 %
—	20	20 %
--	40	40 %
---	60	60 %
----	80	80 %
-----	100	100 %

5. Confirm your setting with **OK**. The bars stop flashing.

4. Check the CO₂ content for the upper heating output (100 %). For CO₂ content limits, see page 23.
5. Check the CO₂ content for the lower heating output (20 %). The CO₂ content must be between 0.5 and 0.9 % below the value of the upper heating output.
6.
 - If the CO₂ content is within the indicated range, continue with point 8.
 - If the CO₂ content lies **outside** the indicated range, check the balanced flue system for tightness; remedy any leaks. Replace gas train if required.
7. Re-check the CO₂ content for the upper and lower heating output.
8. Terminate test mode:
 1. ▲/▼ repeatedly until "**SERV**" flashes.
 2. **OK** to confirm. The selected value flashes.
 3. ▼ repeatedly until **OFF** flashes.
 4. **OK** to confirm. When "**SERV**" disappears, test mode is terminated.
9. Shut down the boiler, remove the flue gas analyser and close flue gas test port (A).





Removing the burner

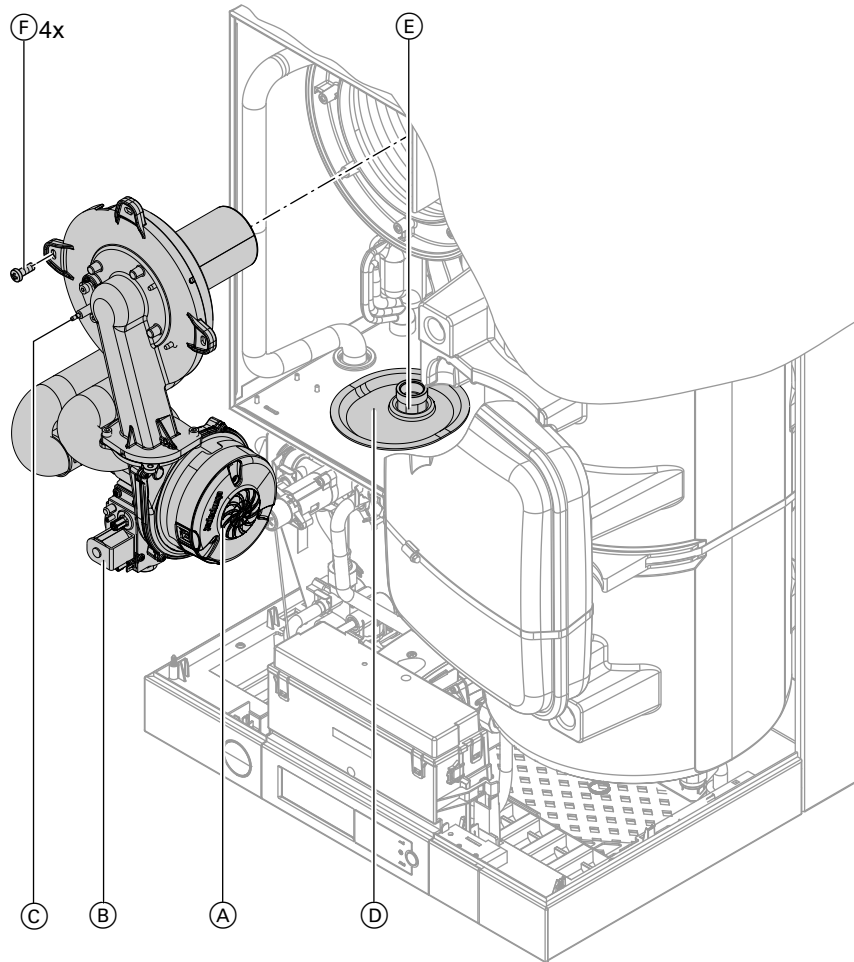

Fig. 23

1. Switch OFF the power supply.
2. Shut off the gas supply.
3. Disconnect the cables from fan motor (A), gas train (B) and electrodes (C).
4. Push grommet (D) down.
5. Undo gas supply pipe fitting (E).
6. Undo 4 screws (F) and remove the burner.



Please note

To prevent damage, never rest the burner on the burner gauze assembly.



Checking the burner gasket and burner gauze assembly

Check burner gasket (A) and burner gauze assembly (D) for damage and replace if necessary.

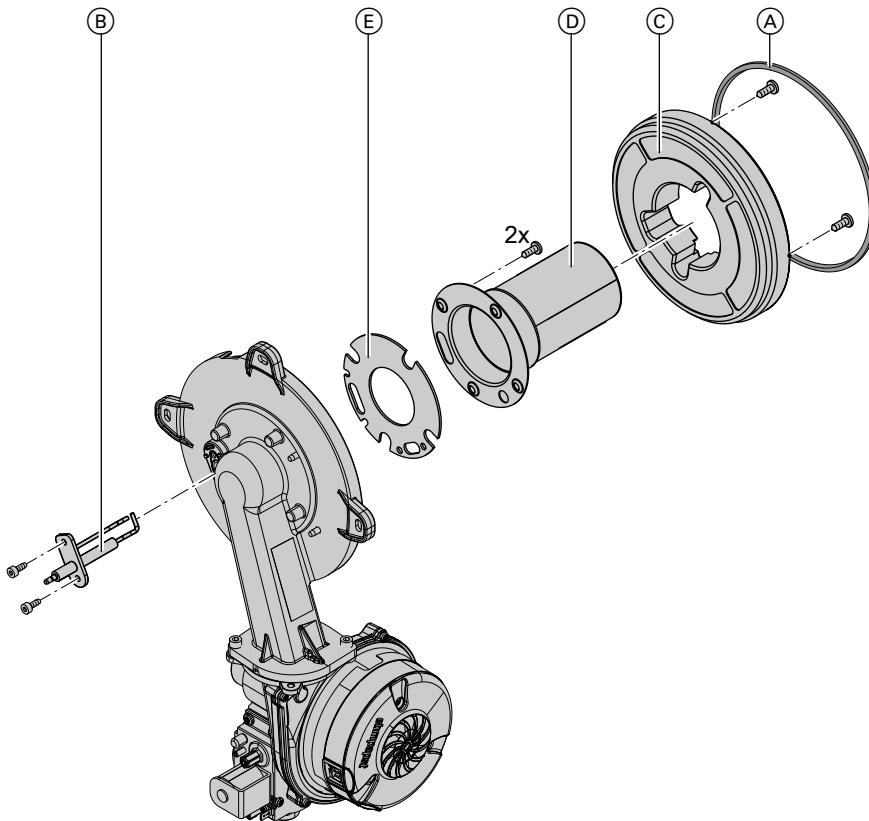

Fig. 24

1. Remove electrode (B).
2. Undo 2 Torx screws and remove thermal insulation ring (C).
3. Undo 2 Torx screws and remove burner gauze assembly (D) with gasket (E).
4. Insert and secure new burner gauze assembly (D) with new gasket (E).

! **Please note**
Tighten screws enough to ensure the components do not suffer damage and will function correctly.

5. Mount thermal insulation ring (C).

! **Please note**
Tighten screws enough to ensure the components do not suffer damage and will function correctly.

6. Fit electrode (B).

! **Please note**
Tighten screws enough to ensure the components do not suffer damage and will function correctly.



Checking and adjusting the electrode

1. Check the electrode for wear and contamination.
2. Clean the electrode with a small brush (not a wire brush) or emery paper.



Checking and adjusting the electrode (cont.)

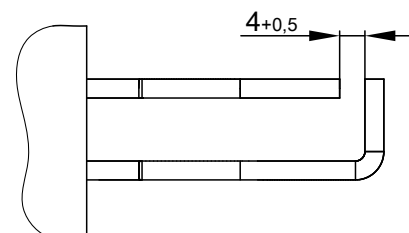
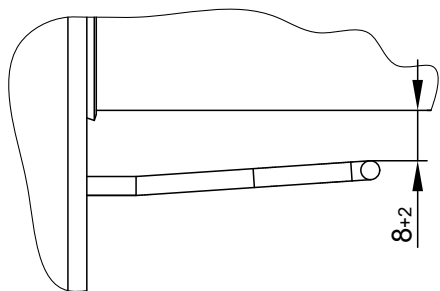

Fig. 25

3. Check the electrode gaps. If the gaps are not as specified or the electrode is damaged, replace the electrode and gasket and align.



Please note

Tighten screws enough to ensure the components do not suffer damage and will function correctly.



Cleaning the heat exchanger



Please note

Scratches to the surfaces of the heat exchanger that come into contact with hot gas can result in corrosion damage.

Never use brushes to clean the heating surfaces.



Please note

Brushing can cause deposits to become lodged in the gaps between the coils.

Never use brushes to clean the heating surfaces.

Note

Discolouration on the heat exchanger surface is a normal sign of use. It has no bearing on the function and service life of the heat exchanger.

The use of chemical cleaning agents is not required.

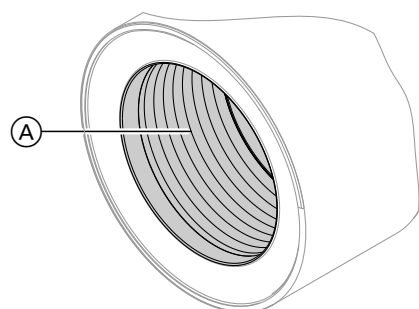

Fig. 26

1. Use a vacuum cleaner to remove combustion residues from heating surface (A) of the heat exchanger.
2. Flush heating surface (A) with water.
3. Check condensate drain and clean trap. See the following chapter.
4. Flush the heating surface again with water. This will also fill the trap with water.



Checking the condensate drain and cleaning the trap

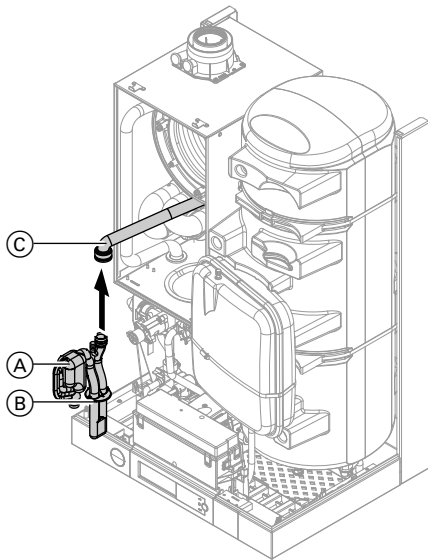

Fig. 27

1. Release hook and remove trap (A) with sealing piece (B). Pull trap (A) upwards away from the drain connection.
2. Remove supply hose (C) from trap (A).
3. Clean trap (A).
4. Insert trap (A) with sealing piece (B). Refit trap (A) to the drain connection.
5. Refit supply hose (C).
6. Fill trap (A) with water. For this, pour approx. 0.3 l of water into the combustion chamber.
7. Check that condensate can drain freely and that the connections are tight.



Installing the burner

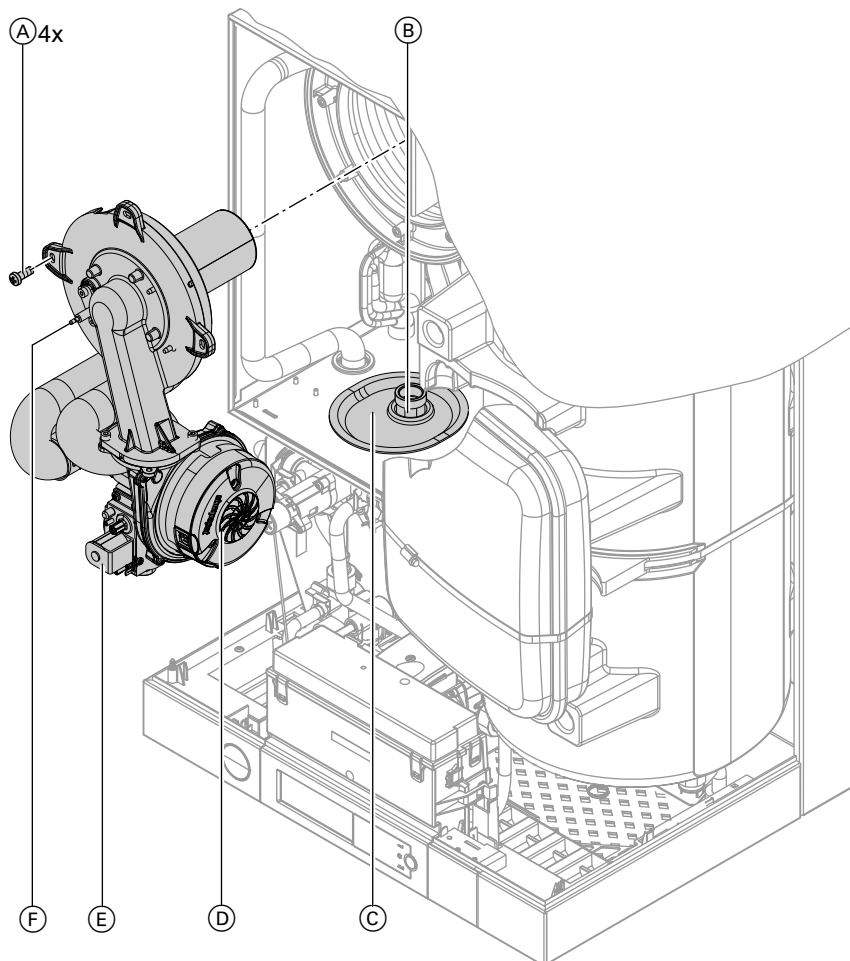

Fig. 28

1. Mount burner and secure with 4 screws (A).
2. Insert the new gasket and tighten the fitting on gas supply pipe (B).





Installing the burner (cont.)

- Tighten 4 screws (A) diagonally.



Please note

Tighten screws enough to ensure the components do not suffer damage and will function correctly.

- Fit cables to fan motor (D), gas train (E) and ignition electrode (F).
- Reopen the gas supply and switch ON the power supply.

- Check the gas connections for tightness.



Danger

Escaping gas leads to a risk of explosion. Check the fitting for gas tightness.



Please note

The use of leak detection spray can result in faulty operation. Leak detection spray must not come into contact with electrical contacts or block the diaphragm opening on the gas valve.

- Push grommet (C) up again.



Checking the diaphragm expansion vessels and system pressure

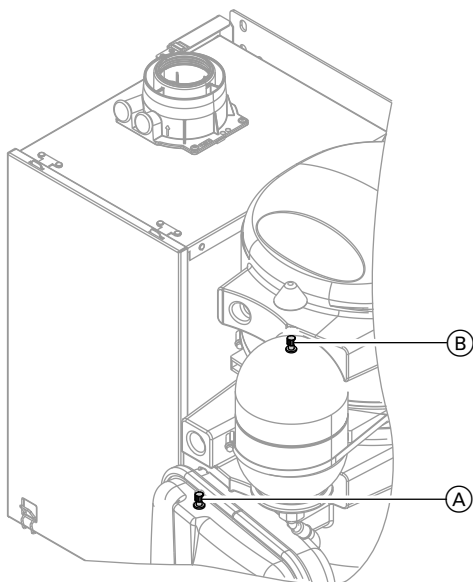

Fig. 29

- (A) Test connector, heating water expansion vessel
- (B) Test connector, DHW expansion vessel (if installed)

Diaphragm expansion vessel on the heating water side

Note

The diaphragm expansion vessel can lose some charge pressure over time. When the boiler heats up, the pressure gauge will indicate a higher pressure of 2 or 3 bar. The safety valve may also respond and discharge the excess pressure.

Check whether the installed diaphragm expansion vessel on the heating water side is adequate for the system water volume. Carry out this test on a cold system.



- Drain the system until the pressure gauge shows "0".
- If the pre-charge pressure of the diaphragm expansion vessel is lower than the static system pressure, top up with nitrogen until the pre-charge pressure is 0.1 to 0.2 bar (10 to 20 kPa) higher.
- Top up with water until the charge pressure of the cooled system is at least 1.0 bar (0.1 MPa), and is 0.1 to 0.2 bar (10 to 20 kPa) higher than the pre-charge pressure of the expansion vessel. Permiss. operating pressure: 3 bar (0.3 MPa)

Diaphragm expansion vessel on the DHW side (if installed)

See page 20.



Checking the safety valve function

   **Checking all connections on the heating water and DHW sides for leaks**

   **Checking the flue system for unrestricted flow and tightness**

   **Checking the firm seating of electrical connections**

   **Checking all gas equipment for tightness at operating pressure**

 **Danger**
Escaping gas leads to a risk of explosion.
Check all gas equipment for tightness.

! **Please note**
The use of leak detection spray can result in faulty operation.
Leak detection spray must not come into contact with electrical contacts or block the diaphragm opening on the gas valve.

   **Fitting the front panel**

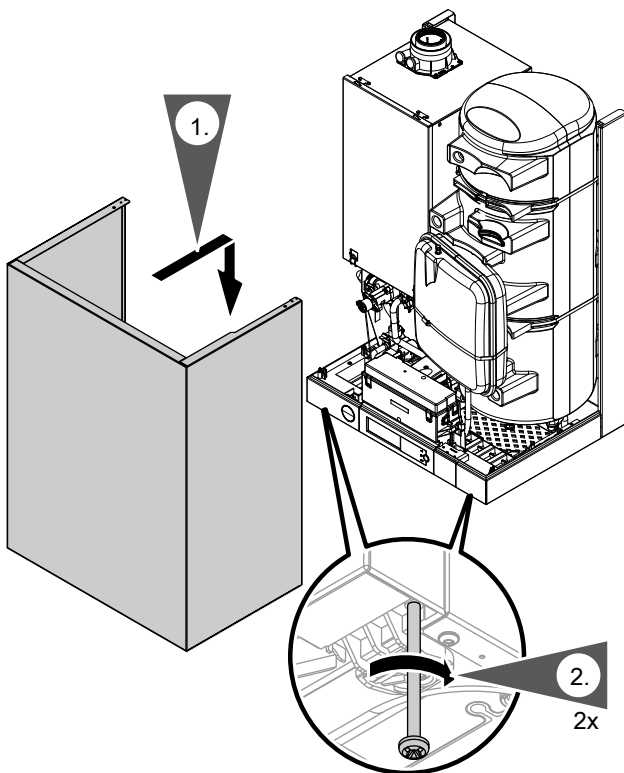

Fig. 30

1. Hook the front panel into place.
2. Tighten screws on the underside of the boiler.

   **Setting display backlighting for standby**

1. Turn ON the ON/OFF switch.
2. Tap **MODE**.
3. ▲/▼ until **CONF1** flashes.





Setting display backlighting for standby (cont.)

4. **OK** to confirm.
"P" appears in the l.h. display area. The r.h. display area flashes.
5. Use ▲/▼ to select "12".
6. **OK** to confirm.
"1" flashes in the l.h. display area.
7. Use ▲/▼ to select "10".
8. **OK** to confirm.
"0" flashes in the r.h. display area.
9. Use ▲/▼ to select the display backlight.
 - "0": Display backlight dimmed
 - or
 - "1": Display backlight off
10. **OK** to confirm.



Setting the display contrast

1. Turn ON the ON/OFF switch.
2. Tap **MODE**.
3. ▲/▼ until **CONF** flashes.
4. **OK** to confirm.
"P" appears in the l.h. display area. The r.h. display area flashes.
5. Use ▲/▼ to select "12".
6. **OK** to confirm.
"1" flashes in the l.h. display area.
7. Use ▲/▼ to select "11".
8. **OK** to confirm.
"3" flashes in the r.h. display area.
9. Use ▲/▼ to adjust the display contrast.
Adjustable from 0 to 6. The higher the value, the greater the contrast.
10. **OK** to confirm.



Setting the signal tone for display operation

1. Turn ON the ON/OFF switch.
2. Tap **MODE**.
3. ▲/▼ until **CONF** flashes.
4. **OK** to confirm.
"P" appears in the l.h. display area. The r.h. display area flashes.
5. Use ▲/▼ to select "12".
6. **OK** to confirm.
"1" flashes in the l.h. display area.
7. Use ▲/▼ to select "9".
8. **OK** to confirm.
"0" flashes in the r.h. display area.
9. Use ▲/▼ to set the signal tone.
 - "0": Signal tone on
 - or
 - "1": Signal tone off
10. **OK** to confirm.



Instructing the system user

The system installer should hand the operating instructions to the system user and instruct the user in operating the system.

Changing from operation with LPG to operation with natural gas

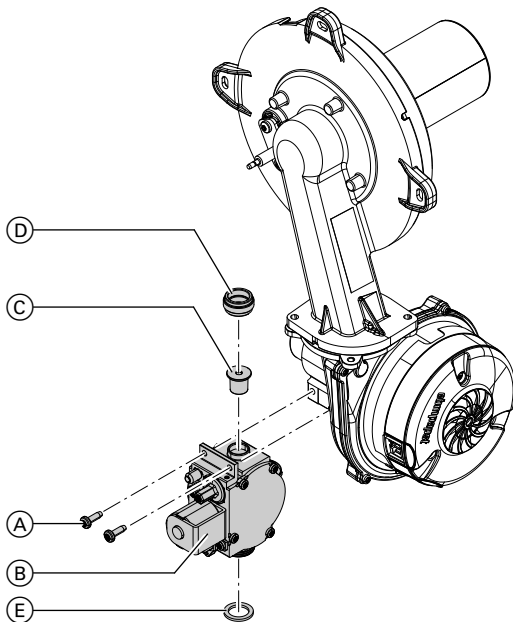

Fig. 31

1. To remove the burner, see page 32.
2. Undo 2 screws (A) and remove gas train (B).
3. Remove gas restrictor (C) for LPG and gasket (D) from gas train (B).
4. Insert new gasket (D) in gas train (B).
If the gasket is missing, order the appropriate conversion kit as an individual part. See parts list (burner assembly).
5. Fit gas train (B) with new gas gasket (E).

! **Please note**
Tighten screws enough to ensure the components do not suffer damage and will function correctly.

6. To refit the burner, see page 35.
7. Remove or void the gas type sticker on the top of the boiler (next to the type plate).
8. Start the boiler and check for leaks.

! **Danger**
Escaping gas leads to a risk of explosion. Check all gas equipment for tightness.

! **Please note**
The use of leak detection spray can result in faulty operation. Leak detection spray must not come into contact with electrical contacts or block the diaphragm opening on the gas valve.

Changing the gas type at the control unit

1. Turn on the ON/OFF switch.
2. Tap **MODE**.
3. ▲/▼ repeatedly until **CONF1** flashes.
4. **OK** to confirm.
"P" is displayed in the l.h. display area. The r.h. display area flashes.
5. Use ▲/▼ to select "12".
6. **OK** to confirm.
"1" flashes in the l.h. display area.
7. Use ▲/▼ to select "5".
8. **OK** to confirm.
"1" flashes in the r.h. display area.
9. Use ▲/▼ to switch the control unit to **"0"** (operation with natural gas).
10. **OK** to confirm.
11. Turn the ON/OFF switch off and on again.
The selected operating mode is saved.

Checking the CO₂ content

See page 30.

Function sequence and possible faults

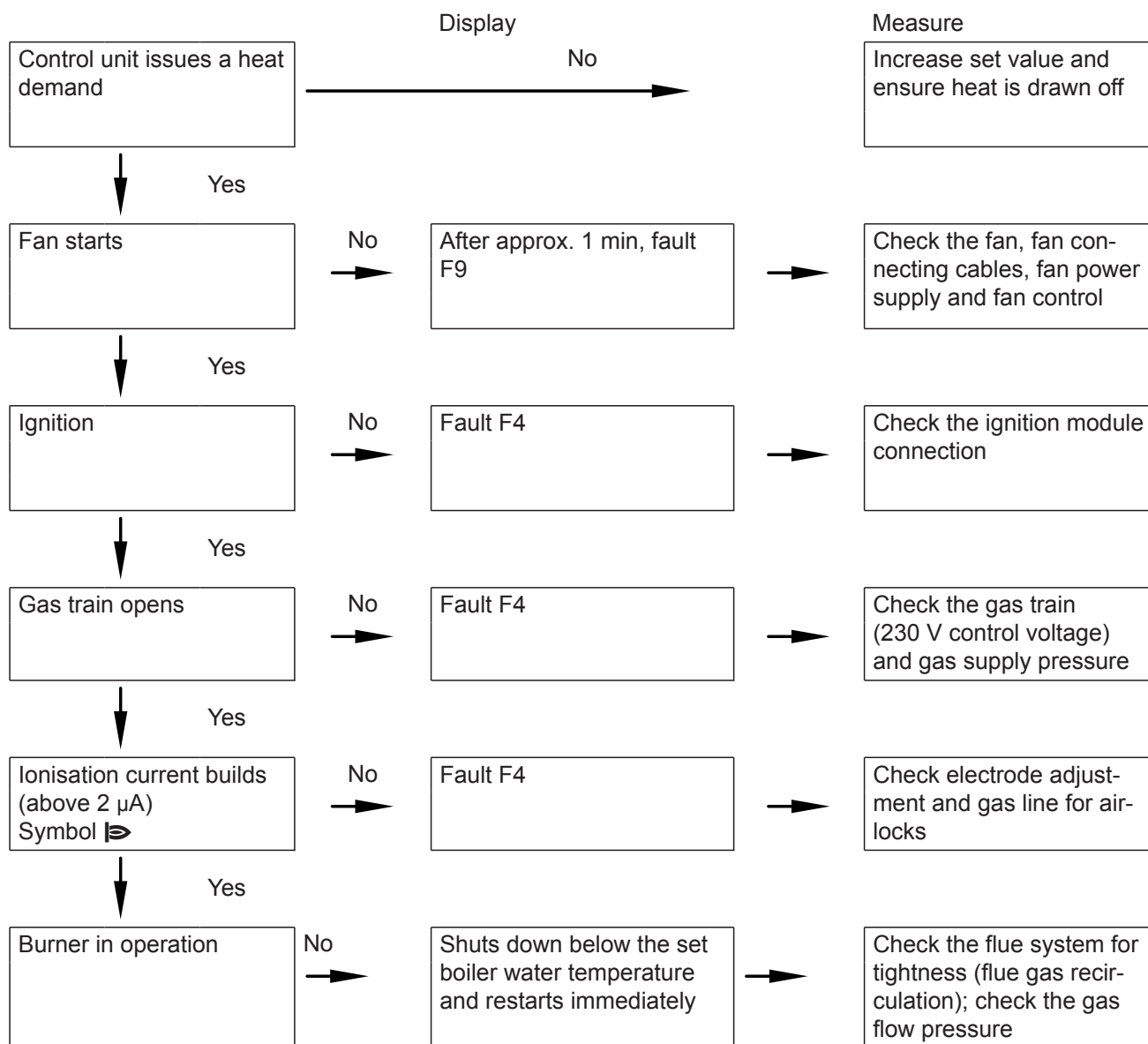

Diagnosis

Fault display

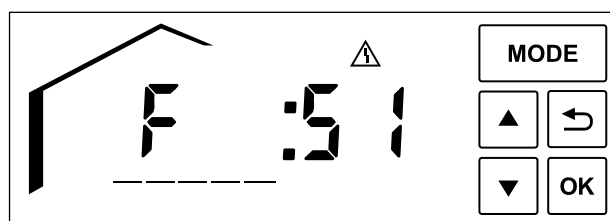



Fig. 32

In case of a fault, the display will show  and the fault code.

If  flashes and "R" appears, the burner is locked out. See page 42.

For an explanation of the fault codes, see the following table.

Fault display (cont.)

Fault code displayed	System characteristics	Cause	Measures
0A	Burner blocked	CO limiter (if installed) has responded. CO concentration too high.	Check the heating system. Remove the cause of escaping CO.
0A	Burner blocked	Gas pressure switch (if installed) has responded. Gas pressure too low.	Check the gas supply.
0C	Burner blocked	Mains voltage too low	Check the power supply.
10	Continuous operation	Short circuit, outside temperature sensor	Check the outside temperature sensor and lead (see page 44).
18	Continuous operation	Lead break, outside temperature sensor	Check the outside temperature sensor and lead (see page 44).
30	Burner blocked	Short circuit, boiler water temperature sensor	Check the boiler water temperature sensor (see page 45).
38	Burner blocked	Lead break, boiler water temperature sensor	Check the boiler water temperature sensor (see page 45).
50	No DHW heating	Short circuit, cylinder temperature sensor	Check the sensor (see page 46).
51	No DHW heating	Short circuit, outlet temperature sensor	Check the sensor (see page 46).
58	No DHW heating	Lead break, cylinder temperature sensor	Check the sensor (see page 46).
59	No DHW heating	Lead break, outlet temperature sensor	Check the sensor (see page 46).
A3	Burner blocked.	Flue gas temperature sensor incorrectly positioned.	Fit flue gas temperature sensor correctly (see page 48).
A9	Control mode without OpenTherm device	Communication error, OpenTherm device	Check connections and cable; replace OpenTherm device if required.
b0	Burner blocked	Short circuit, flue gas temperature sensor	Check the sensor (see page 48).
b7	Emergency mode	Burner control unit fault	Turn the ON/OFF switch off and on again.
b8	Burner blocked	Lead break, flue gas temperature sensor	Check the sensor (see page 48).
E3	Burner in a fault state	Fault in safety chain	Check the temperature limiter and connecting leads (see page 47). Check the control unit and replace if required.
E5	Burner blocked	Internal fault	Check the ionisation electrode and connecting cables. Press "Reset" (see page 42).
F0	Burner blocked	Internal fault	Replace control unit.
F1	Burner in a fault state	Max. flue gas temperature exceeded	Check heating system fill level. Check circulation pump. Vent the system. Press "Reset" (see page 42).
F2	Burner in a fault state	Temperature limiter has responded	Check heating system fill level. Check circulation pump. Vent the system. Check the temperature limiter and connecting leads (see page 47). Press "Reset" (see page 42).



Fault display (cont.)

Fault code displayed	System characteristics	Cause	Measures
F3	Burner in a fault state	Flame signal is already present at burner start	Check ionisation electrode and connecting cable. Press "Reset" (see page 42).
F4	Burner in a fault state	There is no flame signal	Check the ignition/ionisation electrode and connecting cable, gas pressure, gas train, ignition and condensate drain. Press "Reset" (see page 42).
F8	Burner in a fault state	Fuel valve closes too late	Check gas train. Check both control paths. Press "Reset" (see page 42).
F9	Burner in a fault state	Fan speed too low during burner start	Check the fan, fan connecting cables, fan power supply and fan control. Press "Reset" (see page 42).
FA	Burner in a fault state	Fan idle state not reached	Check the fan, fan connecting cables and fan control. Press "Reset" (see page 42).
FC	Burner blocked	Electrical fan control (control unit) faulty	Check fan connecting cable; replace if necessary or replace control unit.
Fd	Burner blocked	Burner control unit fault	Check ignition electrodes and connecting cables. Check whether a strong interference (EMC) field exists near the appliance. Press "Reset" (see page 42). Replace control unit if fault persists.
FF	Burner blocked	Burner control unit fault	Check ignition electrodes and connecting cables. Check whether a strong interference (EMC) field exists near the appliance. Press "Reset" (see page 42). Replace control unit if fault persists.

Press reset (reset burner control unit)

Tap and hold **R** for approx. 2 s.

If the fault has been rectified, fault symbol "△" disappears and the default display is shown or a further fault message is displayed.

If the fault persists, the fault message appears again.

Repairs

- ! Please note**
 Residual water will escape when the boiler or one of the following components is fitted or removed:
- Water-filled pipework
 - Circulation pumps
 - Plate heat exchanger
 - Components fitted in the heating water or DHW circuit
- Water ingress can result in damage to other components.

Protect the following components against ingress of water:

- Control unit (in particular in the service position)
- Electrical components
- Plug-in connections
- Cables and leads

Removing the front panel

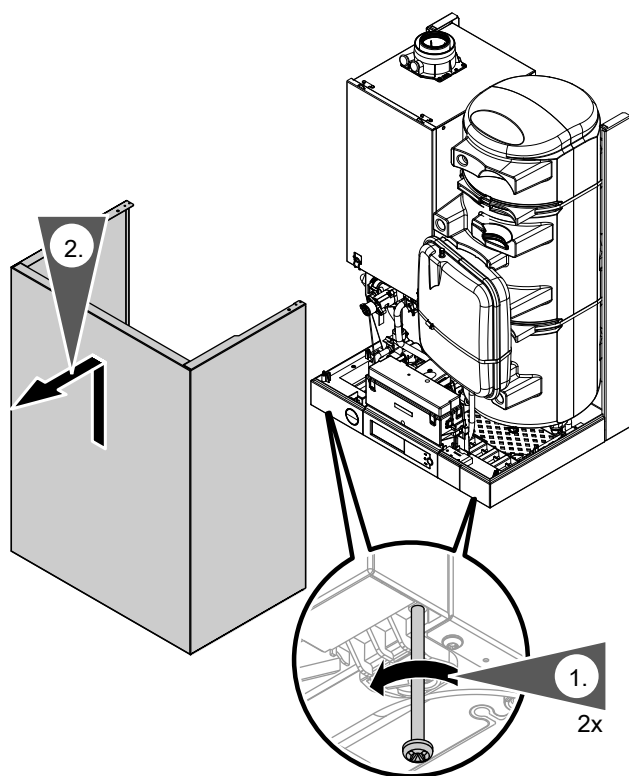

Fig. 33

1. Undo the screws on the underside of the boiler but do not remove them completely.
2. Remove front panel.

Outside temperature sensor

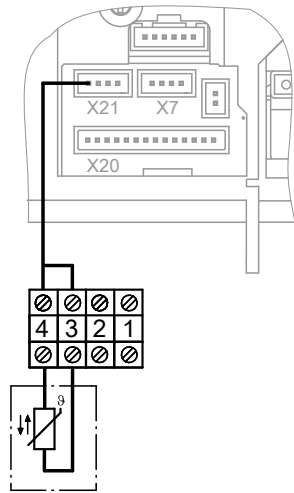

Fig. 34

1. Open the control unit enclosure. See page 15.
2. Disconnect leads from outside temperature sensor.

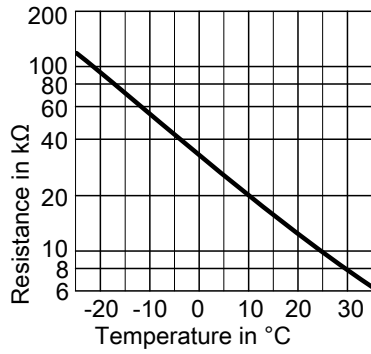

Fig. 35 Sensor type: NTC 10 kΩ

3. Check the sensor resistance and compare it to the curve.
4. In the event of severe deviation replace the sensor.

Repairs (cont.)

Boiler water temperature sensor

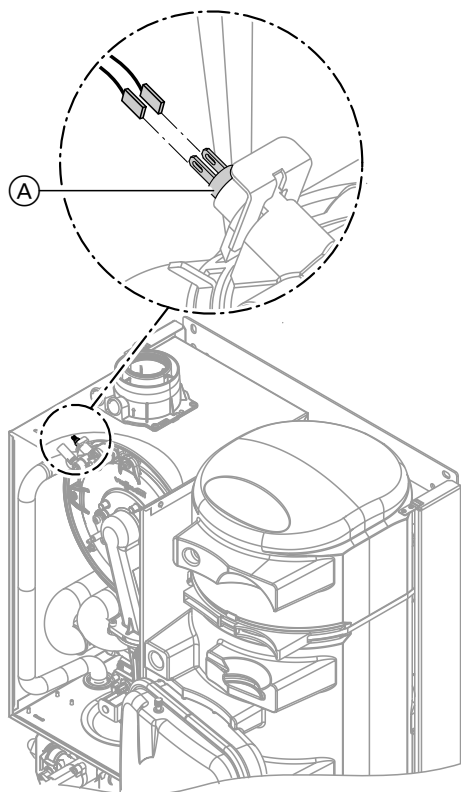

Fig. 36

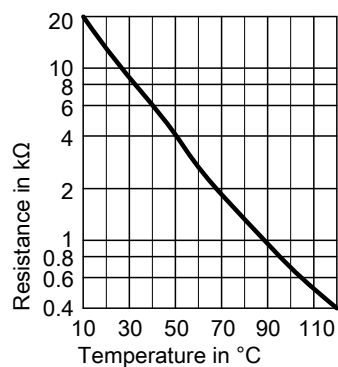

Fig. 37

1. Disconnect leads from boiler water temperature sensor (A) and check the resistance.

2. Check the sensor resistance and compare it to the curve.
3. In the case of severe deviation, drain the boiler on the heating water side and replace the sensor.



Danger

The boiler water temperature sensor is directly immersed in the heating water (risk of scalding). Drain the boiler before replacing the sensor.

Checking the cylinder temperature sensor

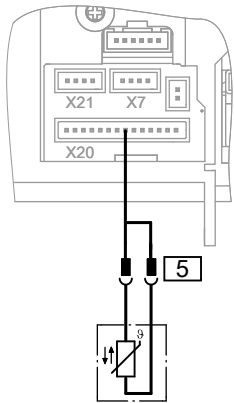

Fig. 38

1. Disconnect plug 5 from the cable harness.

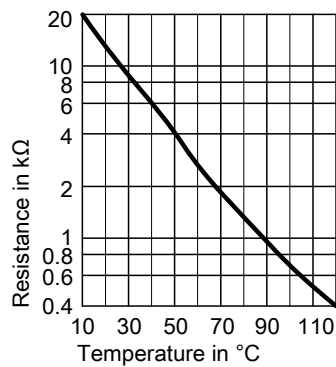

Fig. 39

2. Check the sensor resistance and compare it to the curve.

3. In the event of severe deviation replace the sensor.

Checking the outlet temperature sensor

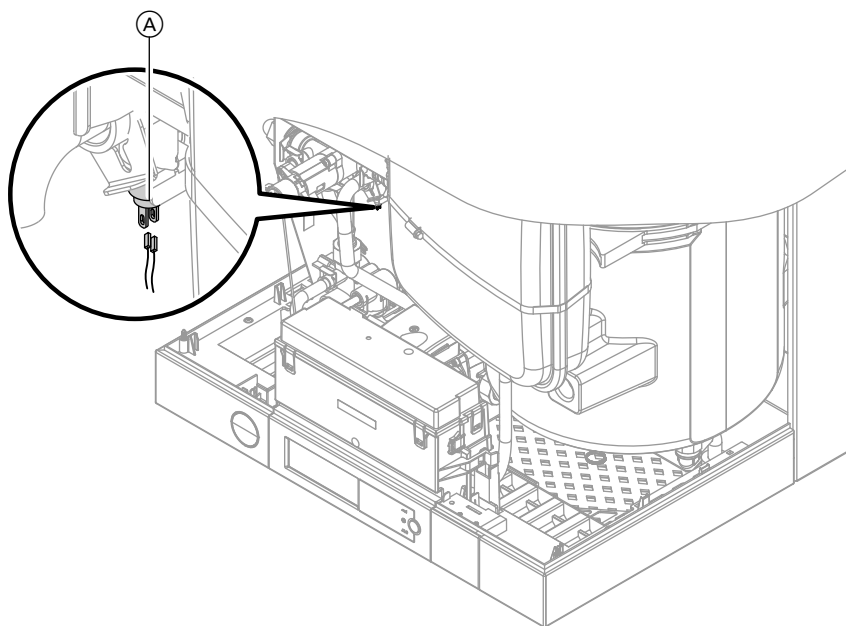

Fig. 40

Repairs (cont.)

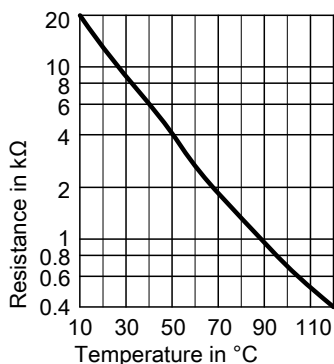

Fig. 41 Sensor type: NTC 10 kΩ

1. Disconnect leads from outlet temperature sensor (A).
2. Check sensor resistance and compare it to the curve.
3. In the event of severe deviation replace the sensor.



Danger

The outlet temperature sensor is directly immersed in the DHW (risk of scalding). Drain the boiler on the DHW side before replacing the sensor.

Checking the temperature limiter

If the burner control unit cannot be reset after a fault shutdown although the boiler water temperature is below approx. 95 °C, check the temperature limiter.

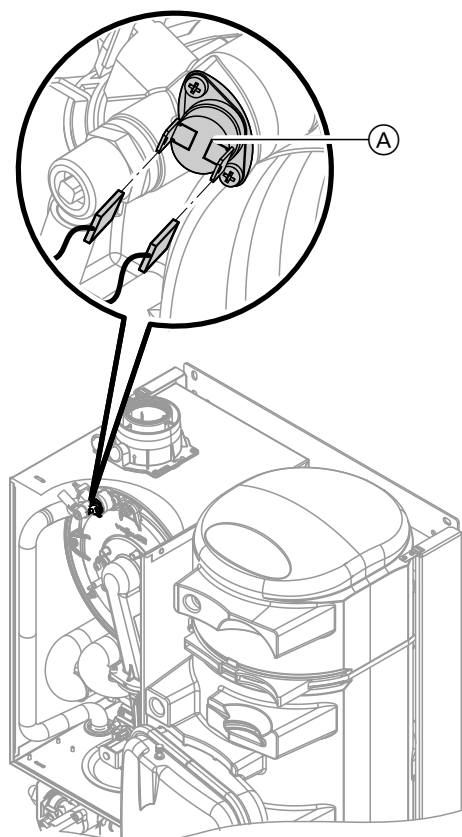

Fig. 42

1. Disconnect the leads from temperature limiter (A).
2. Check the continuity of the temperature limiter with a multimeter.
3. Remove faulty temperature limiter.
4. Install a new temperature limiter.
5. Reset by pressing "Reset" on the control unit (see page 42).

Checking the flue gas temperature sensor

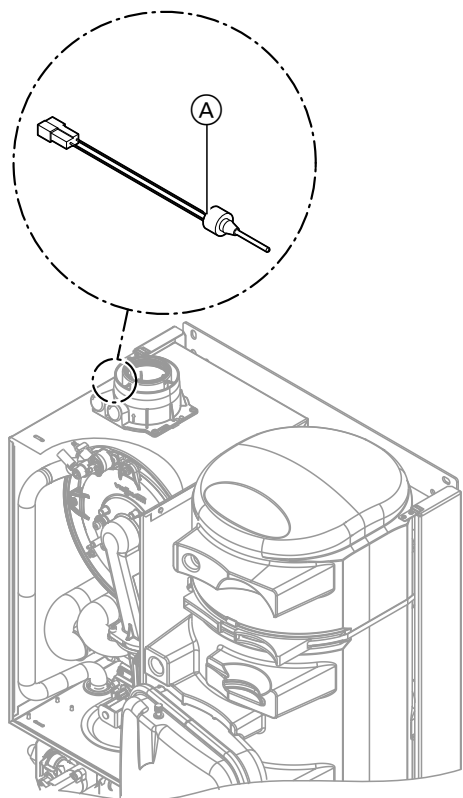

Fig. 43

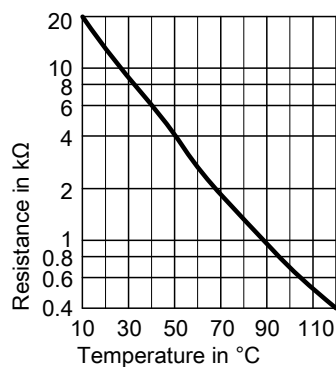

Fig. 44

1. Disconnect leads at flue gas temperature sensor **A**.

2. Check the sensor resistance and compare it to the curve.
3. In the event of severe deviation replace the sensor.

Fault "A3" during commissioning

During commissioning, the control unit checks whether the flue gas temperature sensor is correctly positioned. If the flue gas temperature sensor is incorrectly positioned, commissioning is aborted and fault message A3 is shown.

1. Check whether the flue gas temperature sensor is correctly inserted. See previous diagram.

2. If necessary, correct the position of the flue gas temperature sensor or replace the faulty flue gas temperature sensor.
3. Tap and hold **R** for approx. 2 s and repeat commissioning. The check is repeated until it is completed successfully.

Checking and cleaning the plate heat exchanger

Note

Drain the boiler on the heating water and DHW sides.

Repairs (cont.)

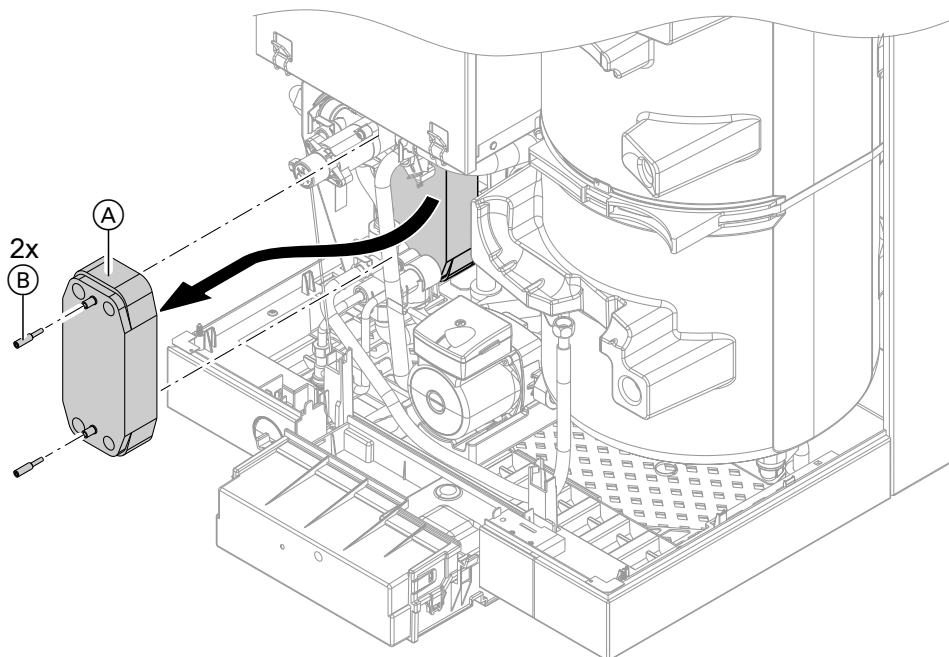

Fig. 45

1. Undo plate heat exchanger (A) (screws B) and pull out forwards.
2. Check the connections on the heating water and DHW sides for contamination and scaling; replace the plate heat exchanger if necessary.
3. Install in reverse order using new gaskets.

Checking the fuse

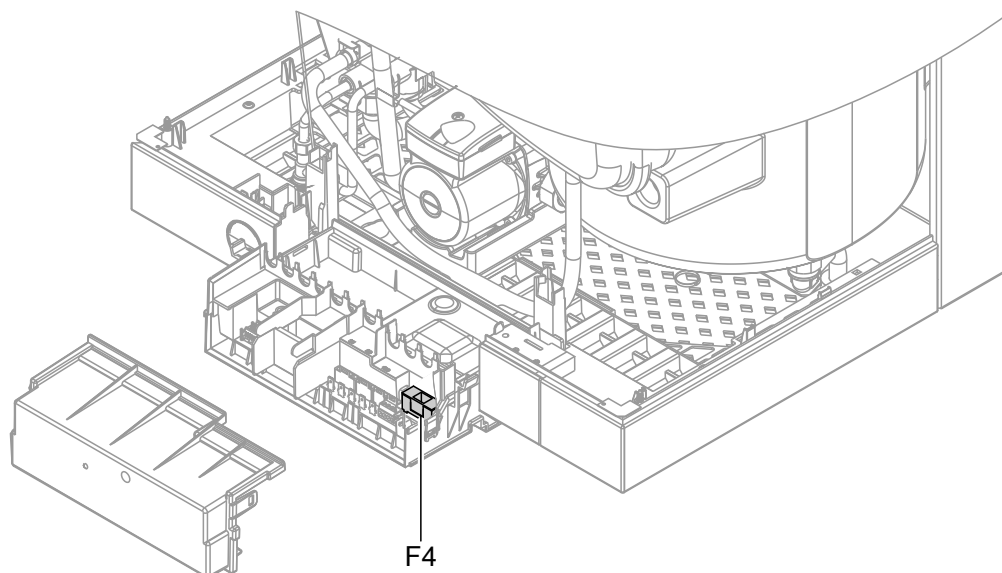

Fig. 46

1. Switch OFF the power supply.
2. Open the control unit enclosure (see page 15).



3. Check fuse F4.

**Danger**

Incorrect or improperly fitted fuses can lead to an increased risk of fire.

- Insert fuses without using any force. Position fuses correctly.
- Only use structurally identical types with the specified response characteristics.

Overview of assemblies

The following details are required when ordering parts:

- Serial no. (see type plate (A))
- Assembly (from this parts list)
- Position number of the individual part within the assembly (from this parts list)

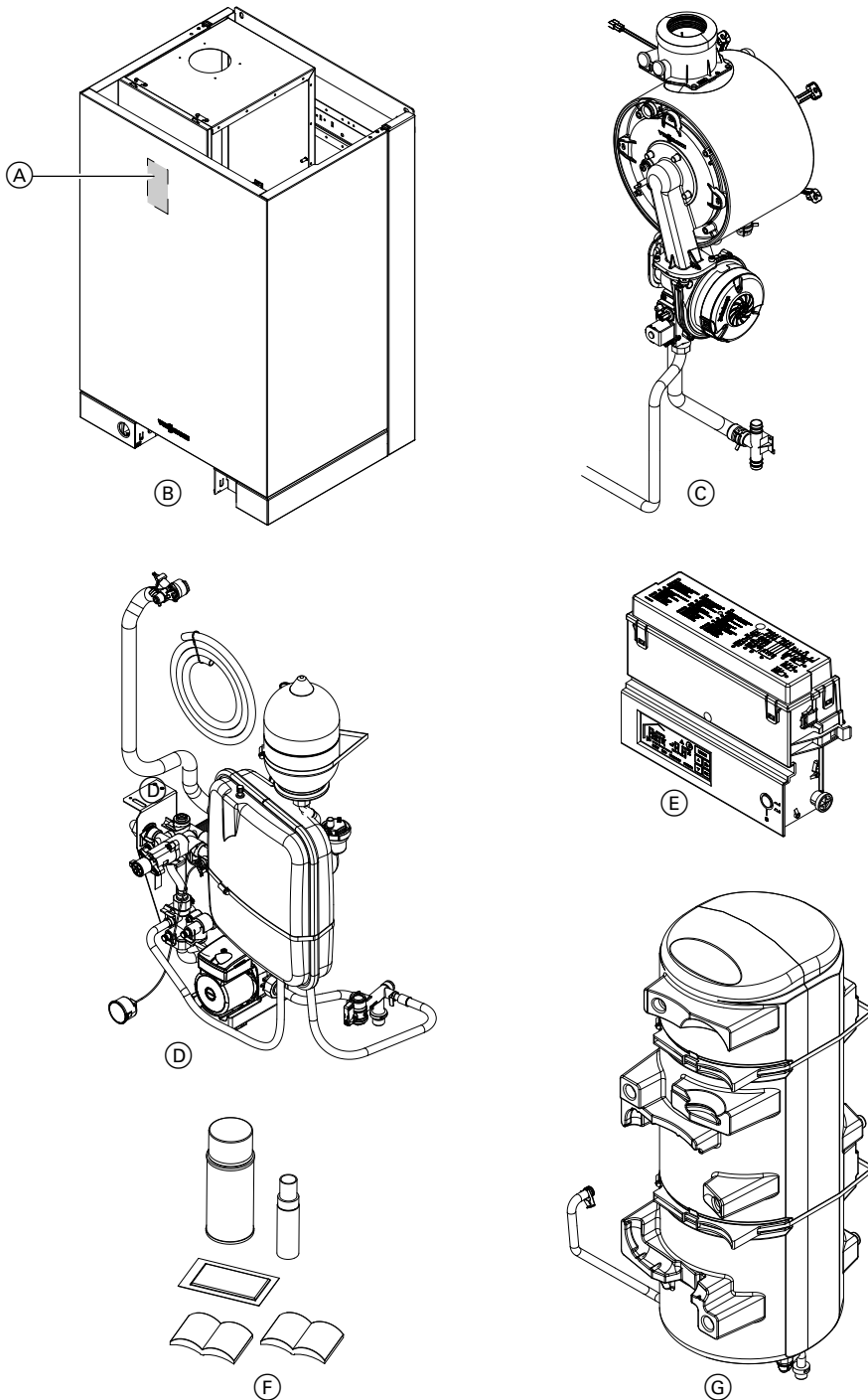

Fig. 47

- (A) Type plate (on the cover panel)
- (B) Casing assembly
- (C) Heat cell assembly
- (D) Hydraulic assembly
- (E) Control unit assembly
- (F) Miscellaneous assembly
- (G) Cylinder assembly

Casing assembly

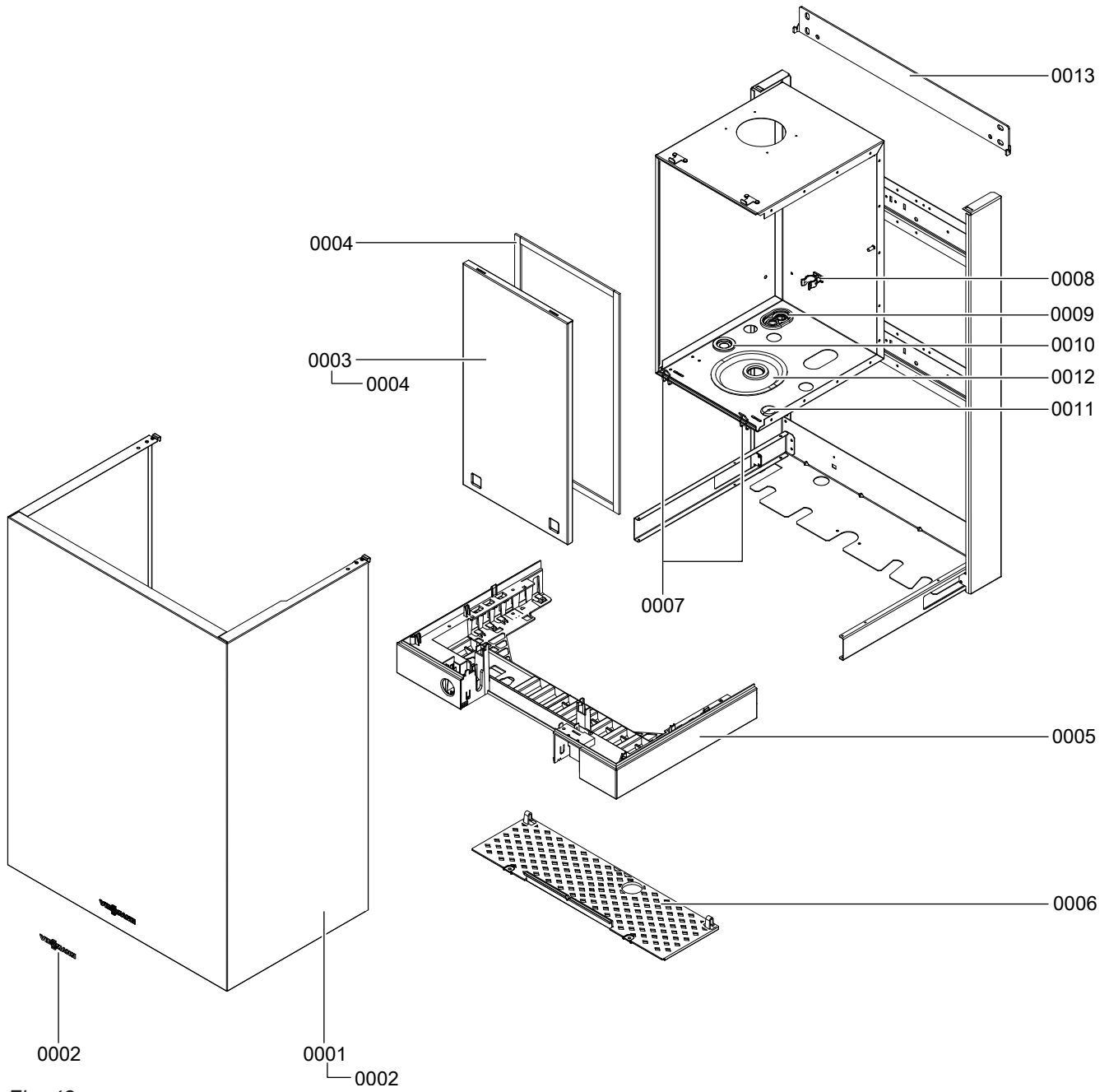

Fig. 48

Casing assembly (cont.)

Pos.	Part
0001	Front panel
0002	Viessmann logo
0003	Cover panel with gasket
0004	Profiled seal
0005	Control unit support
0006	Safety guard 600 mm
0007	Toggle fastener (4 pce)
0008	Pipe clip Ø 18
0009	Air box gasket, trap
0010	Diaphragm grommet Ø 29/18
0011	Cable entry
0012	Air box gasket, gas pipe
0013	Wall mounting bracket

Parts lists

Heat cell assembly

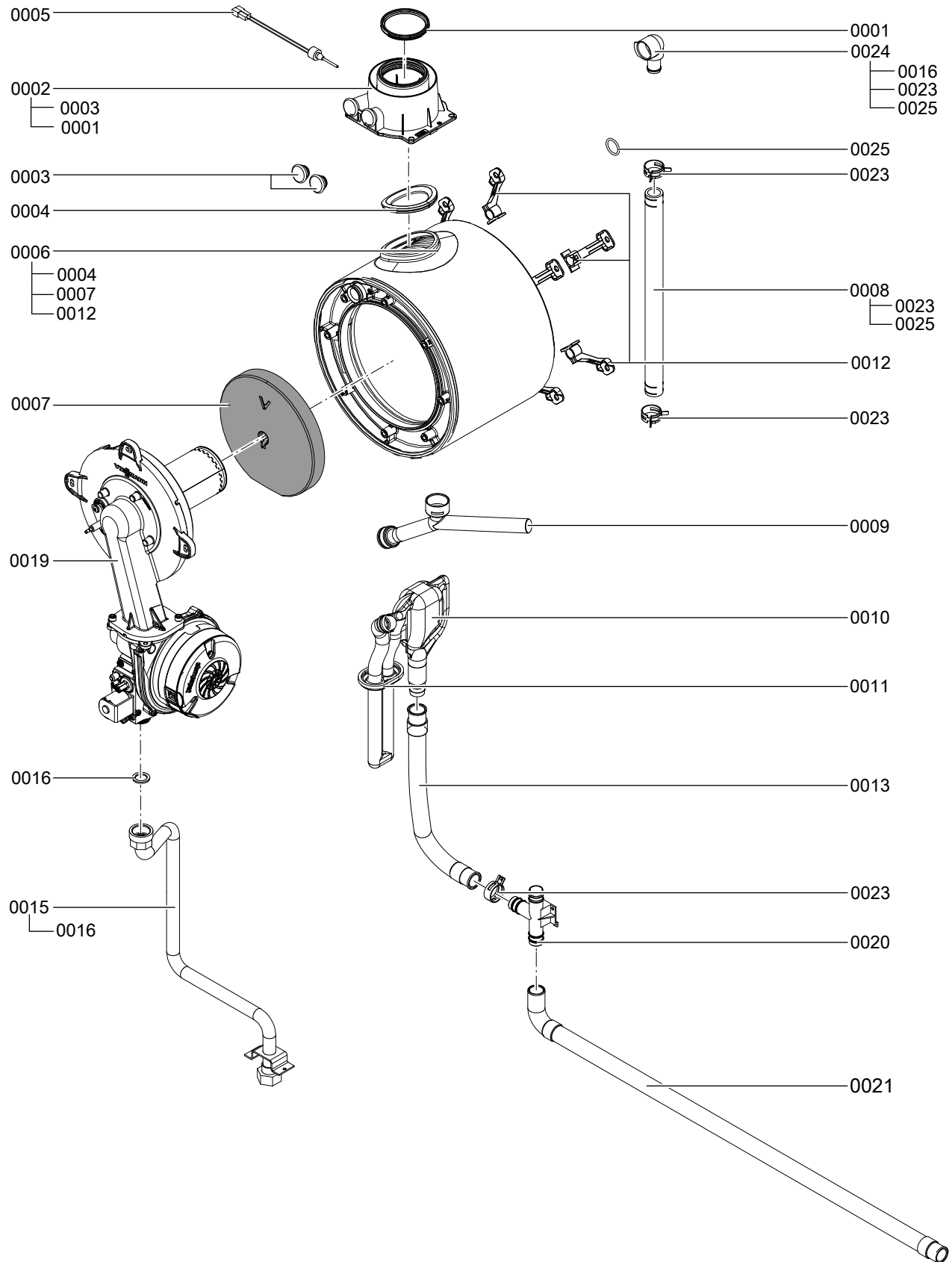

Components

Fig. 49

Heat cell assembly (cont.)

Pos.	Part
0001	Gasket DN 60
0002	Boiler flue connection
0003	Boiler flue connection plug
0004	Flue gasket
0005	Flue gas temperature sensor
0006	Heat exchanger
0007	Thermal insulation block
0008	Profile hose HR (heating return)
0009	Condensate hose
0010	Splash trap
0011	Air box gasket, trap
0012	Heat exchanger mounting bracket (set)
0013	Condensate hose
0015	Gas supply pipe
0016	Gasket A 17 x 24 x 2 (5 pce)
0019	Burner
0020	Tee connector
0021	Corrugated hose 19 x 800 with ferrule/bend
0023	Spring clip DN 25 (5 pce)
0024	Connection elbow HR (heating return), brass
0025	O-ring 20.63 x 2.62 (5 pce)

Burner assembly

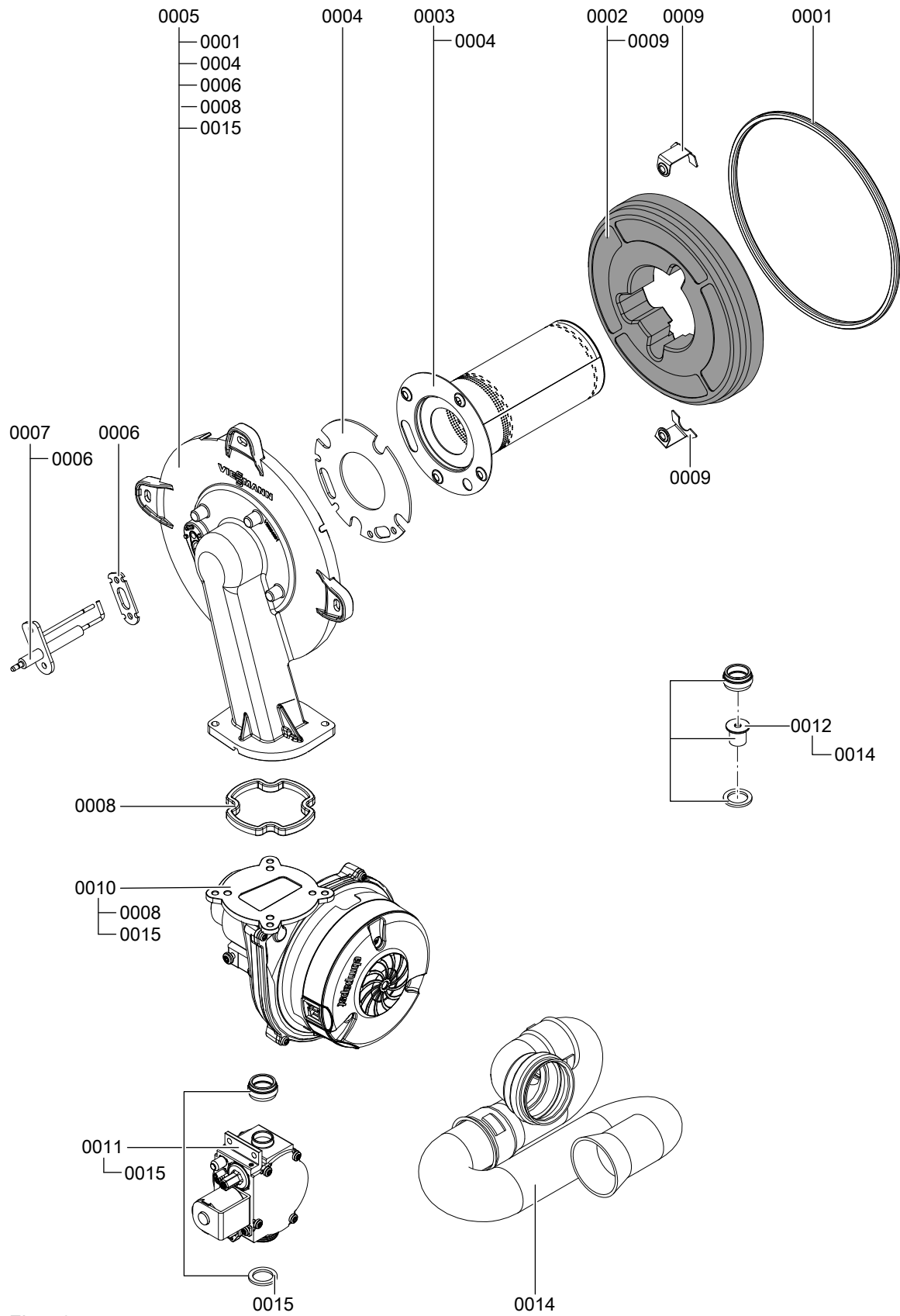

Fig. 50

Burner assembly (cont.)

Pos.	Part
0001	Burner gasket Ø 187 (wearing part)
0002	Thermal insulation ring
0003	Cylinder burner gauze assembly (wearing part)
0004	Burner gauze assembly gasket
0005	Burner door
0006	Gasket, ionisation electrode (5 pce)
0007	Ignition/ionisation electrode
0008	Gasket, burner door flange (wearing part)
0009	Mounting plate, thermal insulation ring (2 pce)
0010	Radial fan NRG 118
0011	Gas valve
0012	Conversion kit G31
0013	Venturi extension
0014	Gasket A 17 x 24 x 2 (5 pce)

Hydraulic assembly

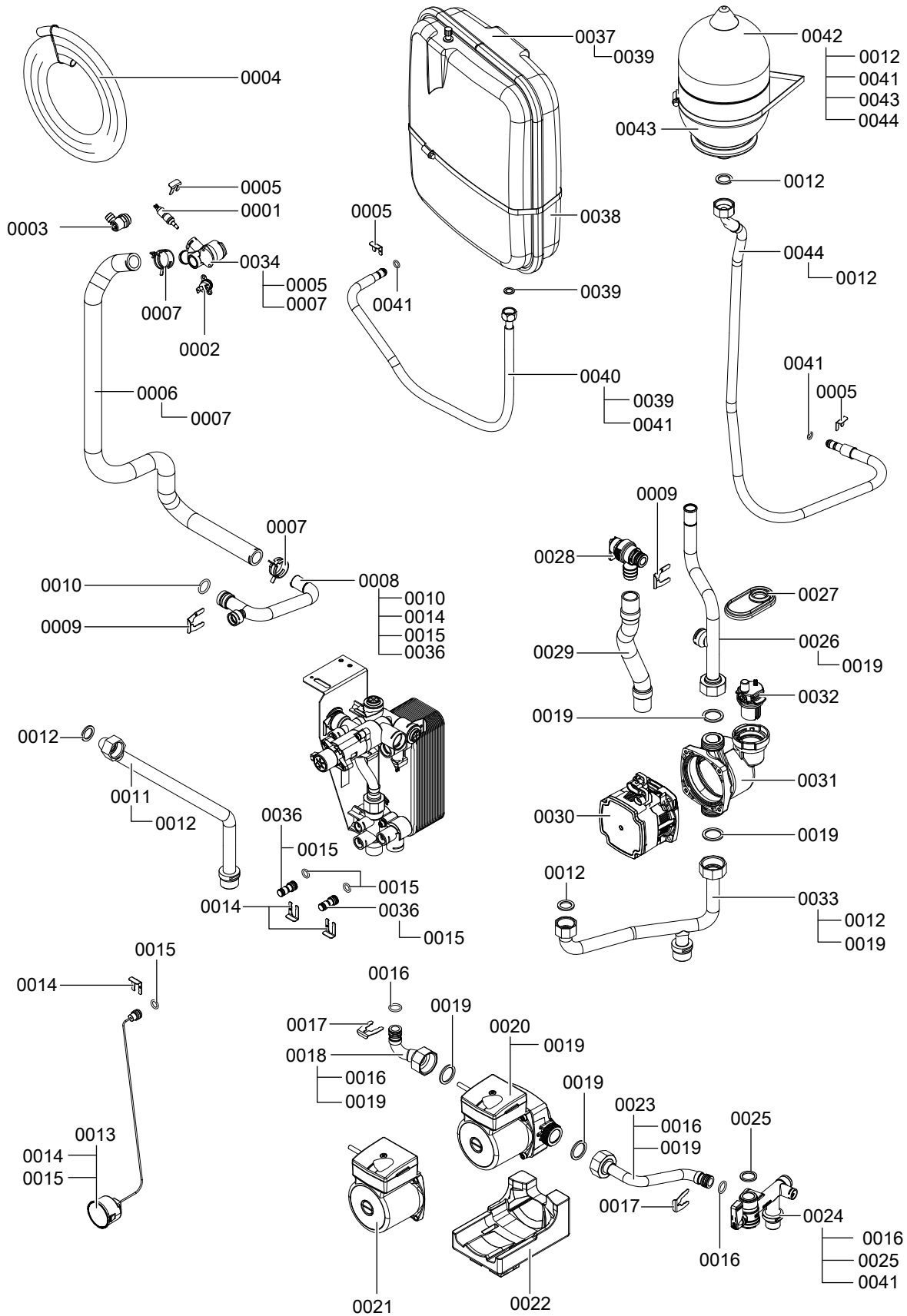

Fig. 51

Hydraulic assembly (cont.)

Pos.	Part
0001	Temperature sensor
0002	Thermal circuit breaker
0003	Air vent valve G 3/8
0004	Hose 10 x 1.5 x 1500
0005	Clip Ø 8 (5 pce)
0006	Profile hose HV (heating flow)
0007	Spring clip DN 25 (5 pce)
0008	Connection pipe HV (heating flow)
0009	Clip Ø 18 (5 pce)
0010	O-ring 17.86 x 2.62 (5 pce)
0011	Connection pipe HV (heating flow)
0012	Gasket A 17 x 24 x 2 (5 pce)
0013	Pressure gauge
0014	Clip Ø 10 (5 pce)
0015	O-ring 9.6 x 2.4 (5 pce)
0016	O-ring 14.3 x 2.4 (5 pce)
0017	Clip Ø 15 (5 pce)
0018	Connection pipe, DHW circulation pump
0019	Gasket A 23 x 30 x 2 (5 pce)
0020	Circulation pump VIUP15-30 CIL2
0021	Motor, circulation pump VIUP -30
0022	Support, cylinder loading pump
0023	Connection pipe KW (cold water)
0024	Ball valve 3/4 - DN 15
0025	Gasket A 18.5 x 24 x 2 (3 pce)
0026	Return pipe
0027	Diaphragm grommet (5 pce)
0028	Safety valve
0029	Condensate hose
0030	Motor, circulation pump UPM3 15-75
0031	CIAO2 casing
0032	Circulation pump quick-action air vent valve
0033	Connection pipe HR (heating return)
0034	Connection elbow HV (heating flow)
0035	Aqua-plate
0036	Plug Ø 8/10
0037	Diaphragm expansion vessel
0038	Hose clip Ø 220 - 240
0039	Gasket A 10 x 15 x 1.5 (5 pce)
0040	MAG connection line (diaphragm expansion vessel) 3/8 x 60
0041	Circular seal washer 8 x 2 (5 pce)
0042	Expansion vessel
0043	Clip Ø 140 - 160
0044	MAG connection line (diaphragm expansion vessel)

Aqua-plate assembly

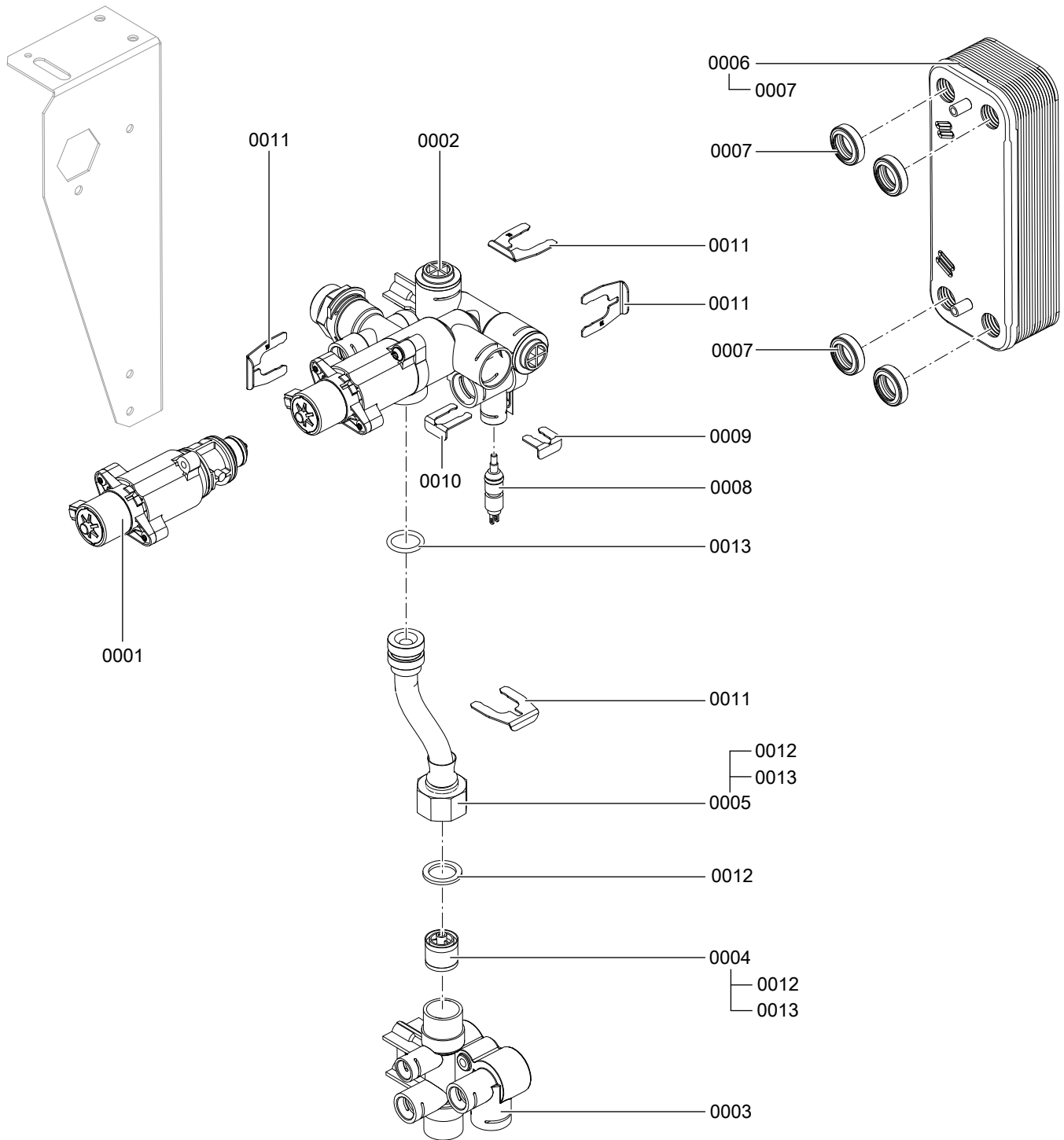

Fig. 52

Aqua-plate assembly (cont.)

Pos.	Part
0001	Valve insert
0002	Flow unit
0003	Return unit
0004	Overflow valve
0005	Overflow line
0006	Plate heat exchanger
0007	Profile gasket (4 pce)
0008	Temperature sensor
0009	Clip Ø 8 (5 pce)
0010	Clip Ø 10 (5 pce)
0011	Clip Ø 18 (5 pce)
0012	Gasket A 17 x 24 x 2 (5 pce)
0013	O-ring 17.86 x 2.62 (5 pce)

Control unit assembly

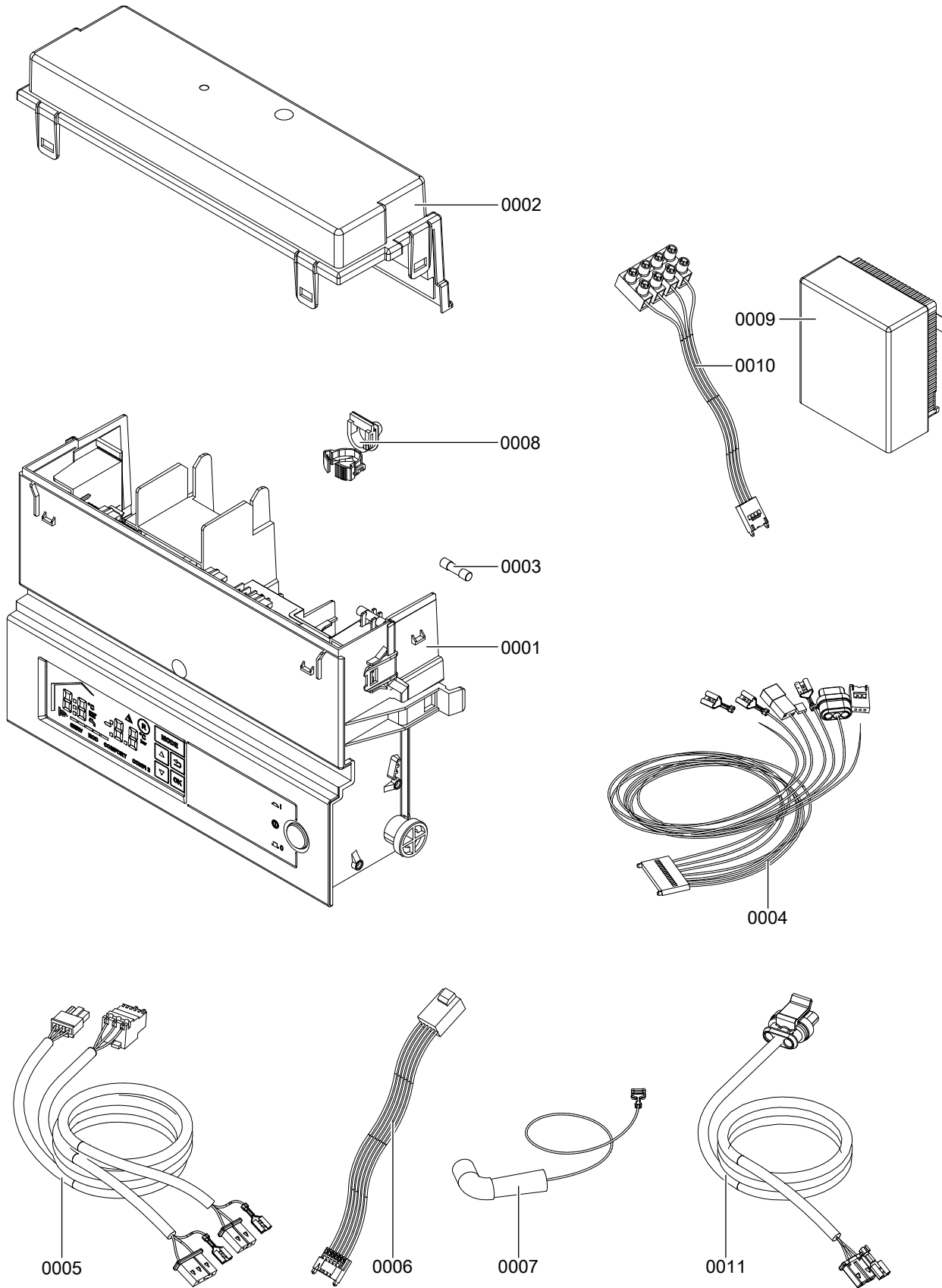

Fig. 53

Control unit assembly (cont.)

Pos.	Part
0001	Control unit VBC113-D10
0002	Cover, wiring chamber
0003	Fuse, 2.5 A (slow), 250 V (10 pce)
0004	Cable harness X20
0005	Cable harness 100/35
0006	Cable harness, Molex stepper motor
0007	Ignition cable with angled plug 5 kOhm
0008	Cable ties (10 pce)
0009	Outside temperature sensor NTC
0010	Cable harness X21
0011	Heating circuit pump connecting cable 20

Cylinder module assembly

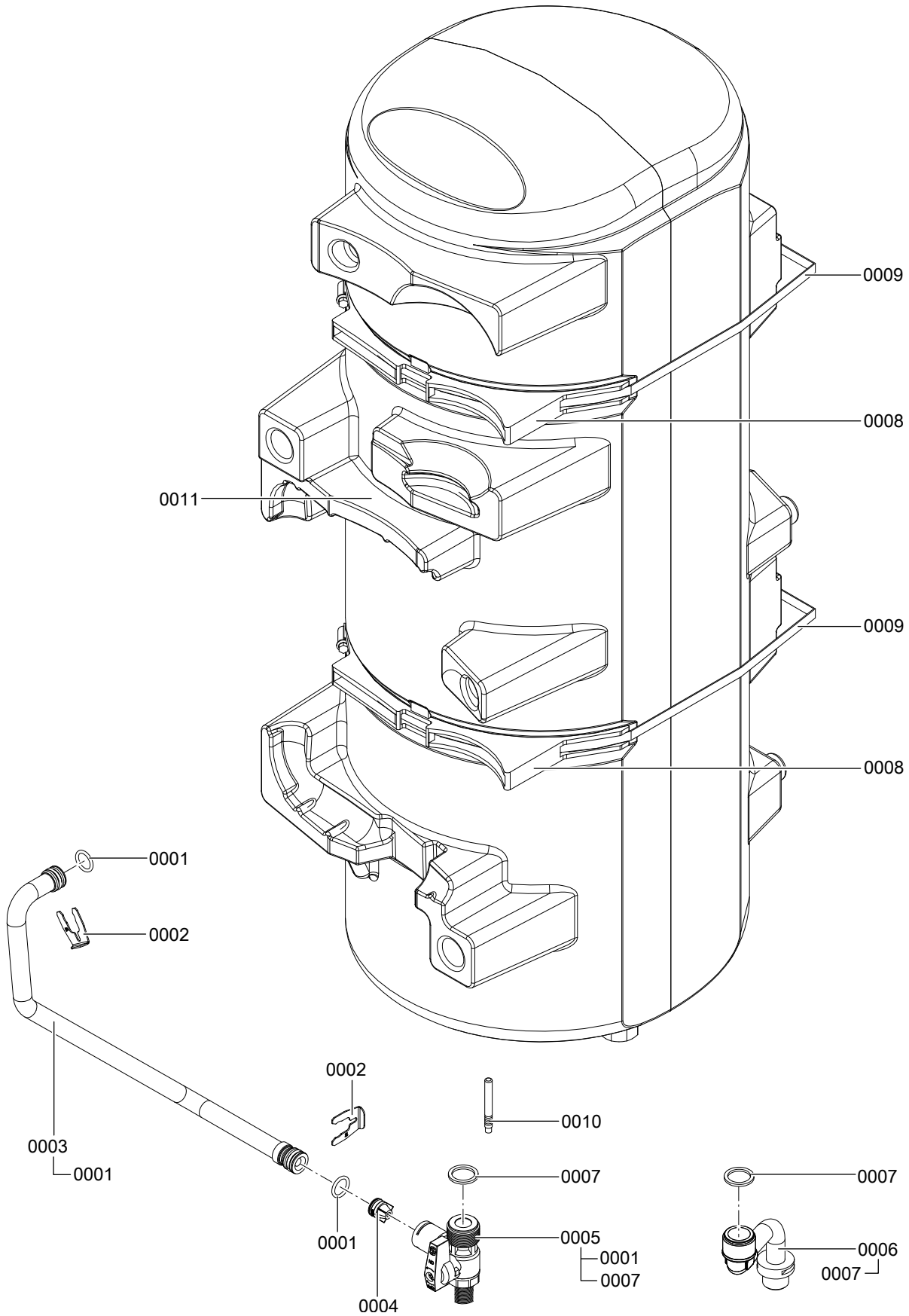

Fig. 54

Cylinder module assembly (cont.)

Pos.	Part
0001	O-ring 14.3 x 2.4 (5 pce)
0002	Clip Ø 15 (5 pce)
0003	Connection pipe WW (DHW)
0004	RV cartridge (non-return valve) DN 15
0005	Right-angle shut-off valve, cylinder
0006	Connection pipe WW (DHW)
0007	Gasket A 18.5 x 24 x 2 (3 pce)
0008	Protective profile
0009	Hose clip Ø 340-360 x 9 perforated
0010	Cylinder temperature sensor NTC
0011	Cylinder

Cylinder assembly

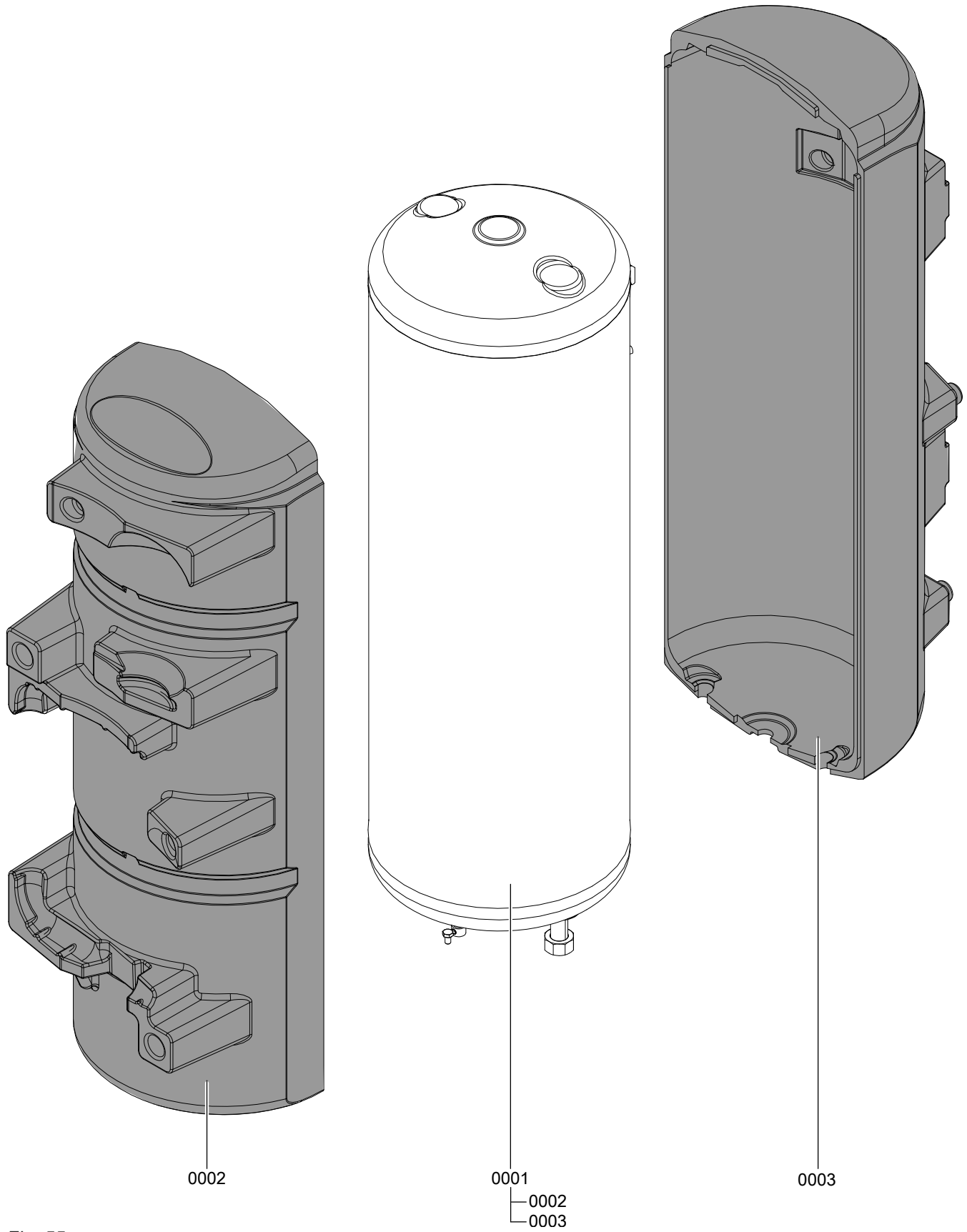

Fig. 55

Cylinder assembly (cont.)

Pos.	Part
0001	Cylinder with thermal insulation
0002	Thermal insulation EPS, front
0003	Thermal insulation EPS, back

Miscellaneous assembly

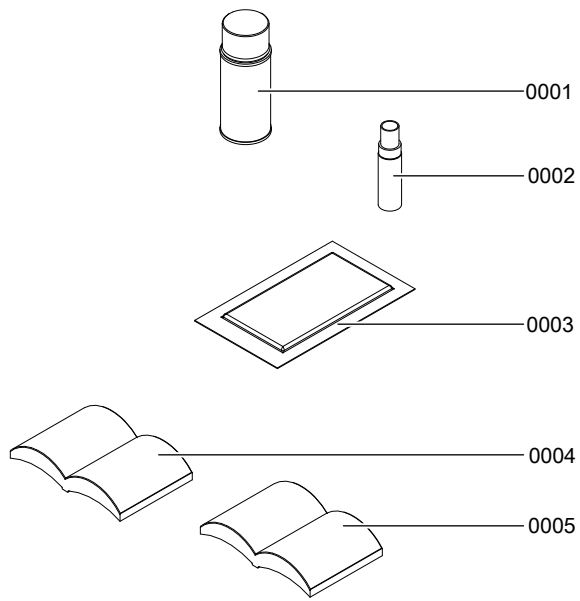

Fig. 56

Miscellaneous assembly (cont.)

Pos.	Part
0001	Touch-up spray paint, white, 150 ml can
0002	Touch-up paint stick, white
0003	Special grease
0004	Installation and service instructions
0005	Operating instructions

Heating mode

In weather-compensated mode, the boiler water temperature is regulated subject to the outside temperature.

Heating curve for weather-compensated control

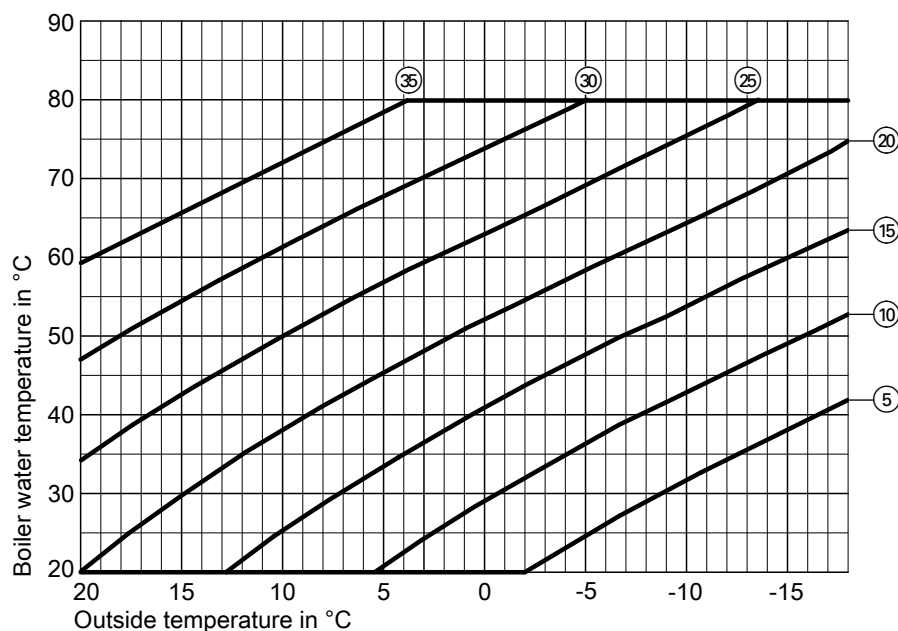



Fig. 57

- ⊗ Code for selected heating curve
The setting can be made in increments of 5 to 35.

Set heating curve

1. Tap ▲/▼.
The set parameter flashes and  will be displayed.
2. Use ▲/▼ to select the parameter.
3. OK to confirm.

Frost protection function

The frost protection function requires an outside temperature sensor to be connected. Frost protection function is active at outside temperatures of $< 5\text{ °C}$. The burner starts and the boiler water temperature is held at 20 °C .

DHW heating

Heating the DHW loading cylinder from cold

The heating circuit pump is switched ON and the 3-way diverter valve will be changed over, if the cylinder temperature sensor captures a temperature lower than the defaulted set value.

- The cylinder loading pump is switched ON if the boiler water temperature \geq set cylinder temperature.
- The burner is switched ON if the boiler water temperature \leq set cylinder temperature, and the cylinder loading pump is switched ON when the required boiler water temperature is reached.

The loading cylinder is heated up to the set cylinder temperature. Heating stops when the specified temperature has been reached at the cylinder temperature sensor.

After loading has stopped, the cylinder loading pump and the 3-way diverter valve remain on for a further 30 s.

Reheating when DHW is drawn off

When DHW is drawn off, cold water enters the lower section of the loading cylinder.

Functions and operating conditions in... (cont.)

The heating circuit pump is switched ON and the 3-way diverter valve is changed over, if the cylinder temperature sensor captures a temperature lower than the defaulted set value.

- The cylinder loading pump is switched ON if the boiler water temperature \geq set cylinder temperature.
- The burner is switched ON if the boiler water temperature \leq set cylinder temperature, and the cylinder loading pump is switched ON when the required boiler water temperature is reached.

DHW is regulated to the set temperature via the outlet temperature sensor.

After the draw off process has ended the loading cylinder continues to be heated up, until the set DHW temperature has been reached at the cylinder temperature sensor.

The cylinder loading pump and the 3-way diverter valve remain ON for a further 30 s.

(cont.)

Settings and test values		Commis- sioning	Mainte- nance/ service	Mainte- nance/ service	Mainte- nance/ service	Mainte- nance/serv- ice
Date						
Signature						
Gas type	G					
Static pressure	<i>mbar</i> <i>kPa</i>					
Supply pressure (flow pres- sure)	<i>mbar</i> <i>kPa</i>					
Carbon dioxide content CO₂						
▪ Upper heating output	<i>% by vol.</i>					
▪ Lower heating output	<i>% by vol.</i>					
Oxygen content O₂						
▪ Upper heating output	<i>% by vol.</i>					
▪ Lower heating output	<i>% by vol.</i>					
Carbon monoxide content CO	<i>ppm</i>					

Specification

Gas condensing storage combi boiler, category II _{2H3P}

Rated heating output range in heating mode			
T_F/T_R 50/30 °C (P(50/30))	kW	4.7 (6.5)^{*1} – 26	5.9 (8.8)^{*1} – 35
T_F/T_R 80/60 °C (Pn(80/60))	kW	4.3 (5.9)^{*1} – 23.8	5.4 (8.0)^{*1} – 32.0
Rated heating output range for DHW heating	kW	4.3 (5.9) ^{*1} – 29.3	5.4 (8.0) ^{*1} – 35.0
Rated heating input range (Q_n)	kW	4.4 (6.1) ^{*1} – 30.5	5.5 (8.2) ^{*1} – 36.5
Connection values			
Relative to the max. load for:			
- Natural gas H	m ³ /h	3.23	3.86
- LPG P	kg/h	2.38	2.85
Rated voltage	V	230	
Rated frequency	Hz	50	
Rated current	A	2.0	
Backup fuse (max.)	A	16	
Power consumption (max.)	W	152	151
Weight	kg	62	64
Permissible ambient temperature			
- during operation	°C	0 to +40	
- during storage and transport	°C	-20 to +65	
IP rating		IP X4 to EN 60529 (only for room sealed operation)	
Protection class		I	
Temperature limiter setting	°C	100 (fixed)	
Product ID		CE-0063CQ3356	

Note

The supply values are only for reference (e.g. in the gas contract application) or for a supplementary, rough estimate to check the volumetric settings. Due to factory settings, the gas pressure must not be altered from these values. Reference: 15 °C, 1013 mbar (101.3 kPa).

^{*1} Only when operating with LPG P

Final decommissioning and disposal

Viessmann products can be recycled. Components and substances from the system are not part of ordinary household waste.

For decommissioning the system, isolate the system from the power supply and allow components to cool down where appropriate.

All components must be disposed of correctly.

Declaration of conformity

Vitodens 111-W, type B1LD

We, Viessmann Werke GmbH & Co. KG, D-35107 Allendorf, declare as sole responsible body that the named product complies with the provisions of the following directives and regulations:

2009/142/EC	Gas Appliances Directive* ²
2016/426/EU	Gas Appliances Regulation* ³
2014/30/EU	EMC Directive
2014/35/EU	Low Voltage Directive
2009/125/EC	Ecodesign Framework Directive
2010/30/EU	Energy Consumption Labelling Framework Directive
811/2013	EU Regulation "Energy Efficiency Label"
813/2013	EU Regulation "Energy Efficiency Requirements"

Applied standards:

EN 15036-1: 2006
EN 15502-1: 2012 + A1: 2015
EN 15502-2-1: 2012
EN 55014-1: 2006 + A1: 2009 + A2: 2011
EN 55014-2: 2015
EN 60335-1: 2012 + AC: 2014
EN 60335-2-102: 2006 + A1: 2010
EN 61000-3-2: 2006 + A1: 2009 + A2: 2009 + 2014
EN 61000-3-3: 2013

In accordance with the listed directives, this product is designated with **CE-0063**.

Allendorf, 1 September 2017

Viessmann Werke GmbH & Co. KG



Authorised signatory Reiner Jansen
Head of Strategic Quality Management

Manufacturer's declaration

This product meets the requirements of the Efficiency Directive (92/42/EEC) for **condensing boilers**.

*² Valid until 20 / 04 / 2018

*³ Valid from 21 / 04 / 2018

Keyword index

B		I	
Boiler water temperature sensor	45	Ignition.....	33
Burner gasket.....	33	Ignition electrode.....	33
Burner gauze assembly.....	33	Ionisation electrode.....	33
Burner installation.....	35		
Burner removal.....	32	L	
		Limits	
C		– Flue gas values.....	23
CO ₂ content check.....	30	Loading cylinder, filling.....	21
Cold water connection.....	8	LPG.....	22
Combustion chamber cleaning.....	34		
Commissioning.....	19	M	
Condensate.....	13	Max. heating output.....	24
Condensate drain.....	13, 35		
Connection diagram.....	72	O	
Connections.....	8, 11	Outlet temperature sensor.....	46, 48
Connections on the water side.....	11	Output adjustment	
Control unit, opening.....	15	– Shared connection.....	26
Cylinder temperature sensor	46	Output matching	
		– Flue pipe length.....	26
D		Output reduction.....	24
DHW connection.....	8	Outside temperature sensor.....	44
Draining.....	8		
		P	
E		Plate heat exchanger.....	48
Electrical connections.....	15	Power supply.....	16
		Product information.....	7
F		Pump rate adjustment.....	25
Fault.....	40		
Fault code.....	40	R	
Fault display.....	40	Report.....	73
Filling.....	8	Reset.....	42
Filling function.....	19		
Filling the system.....	19	S	
Flue pipe.....	14	Safety chain	47
Frost limit.....	70	Safety valve.....	8, 13
Frost protection.....	70	Shared flue system connection.....	26
Function sequence.....	40	Static pressure.....	23
Fuse.....	49	Supply pressure.....	23
		System filling.....	19, 21
G		System pressure.....	19
Gas connection.....	8, 13		
Gas supply pressure.....	23	T	
Gas train	23	Temperature limiter.....	47
Gas type, changing		Trap.....	13, 35
– At the control unit.....	39	Troubleshooting.....	43
– LPG.....	22, 39		
Gas type selected.....	23	V	
		Ventilation air pipe.....	14
H		Venting.....	21
Heat exchanger cleaning.....	34		
Heating curve.....	70	W	
Heating flow.....	8	Wall mounting.....	10
Heating return.....	8	Weather-compensated mode.....	70





Applicability

Serial No.:

7570732

7570733

Viessmann Werke GmbH & Co. KG
D-35107 Allendorf
Telephone: +49 6452 70-0
Fax: +49 6452 70-2780
www.viessmann.com

Viessmann Limited
Hortonwood 30, Telford
Shropshire, TF1 7YP, GB
Telephone: +44 1952 675000
Fax: +44 1952 675040
E-mail: info-uk@viessmann.com

5697 789 GB Subject to technical modifications.