

Installation and service instructions

for contractors

VIESSMANN

Vitodens 100-W

Type **WB1B**, 9.0 to 35.0 kW

Wall mounted gas fired condensing boiler

Natural gas and LPG version

Gas Council no.

41-819-12; 41-819-13; 41-819-14 (gas fired condensing boilers)

47-819-18; 47-819-19; 47-819-20 (gas fired condensing combi boilers)



VITODENS 100-W



Safety instructions



Please follow these safety instructions closely to prevent accidents and material losses.

Safety instructions explained



Danger

This symbol warns against the risk of injury.



Please note

This symbol warns against the risk of material losses and environmental pollution.

Note

Details identified by the word "Note" contain additional information.

Target group

These instructions are exclusively designed for qualified personnel.

- Work on gas equipment must only be carried out by a qualified gas fitter.
- Work on electrical equipment must only be carried out by a qualified electrician.
- The system must be commissioned by the system installer or a qualified person authorised by the installer.

Regulations

Observe the following when working on this system

- all legal instructions regarding the prevention of accidents,
- all legal instructions regarding environmental protection,
- the Code of Practice of relevant trade associations,

- all current safety regulations as defined by DIN, EN, DVGW, TRGI, TRF, VDE and all locally applicable standards,
- Gas Safety (Installation & Use) Regulations
 - the appropriate Building Regulation either the Building regulations, the Building Regulation (Scotland), Building Regulations (Northern Ireland),
 - the Water Fittings Regulation or Water Bylaws in Scotland,
 - the current I.E.E. Wiring Regulations.

If you smell gas



Danger

Escaping gas can lead to explosions which may result in serious injury.

- Never smoke. Prevent naked flames and sparks. Never switch lights or electrical appliances ON or OFF.
- Close the gas shut-off valve.
- Open windows and doors.
- Remove all people from the danger zone.
- Notify your gas or electricity supplier from outside the building.
- Shut off the electricity supply to the building from a safe place (outside the building).

Safety instructions (cont.)

If you smell flue gas



Danger

Flue gas can lead to life-threatening poisoning.

- Shut down the heating system.
- Ventilate the boiler room.
- Close all doors leading to the living space.

Working on the system

- When using gas as fuel, also close the main gas shut-off valve and safeguard against unauthorised reopening.
- Isolate the system from the power supply and check that it is no longer 'live', e.g. by removing a separate fuse or by means of a main isolator.
- Safeguard the system against unauthorised reconnection.



Please note

Electronic modules can be damaged by electro-static discharges.

Touch earthed objects, such as heating or water pipes, to discharge static loads.

Repair work



Please note

Repairing components which fulfil a safety function can compromise the safe operation of your heating system.

Replace faulty components only with original Viessmann spare parts.

Ancillary components, spare and wearing parts



Please note

Spare and wearing parts which have not been tested together with the heating system can compromise its function. Installing non-authorised components and non-approved modifications/conversion can compromise safety and may invalidate our warranty. For replacements, use only original spare parts from Viessmann or those which are approved by Viessmann.

Index

Installation instructions

Preparing for installation

Product information.....	5
Preparing for installation.....	5

Installation sequence

Installing the boiler and making all connections.....	9
Opening the control unit.....	13
Electrical connections.....	14

Service instructions

Commissioning, inspection, maintenance

Steps - commissioning, inspection and maintenance.....	17
Further details regarding the individual steps.....	18

Troubleshooting

Function sequence and possible faults.....	32
Fault messages on the display.....	33
Repairs.....	37

Gas type conversion

Converting from LPG to natural gas	49
--	----

Control unit

Functions and operating conditions in weather-compensated mode	52
--	----

Designs

Connection and wiring diagram.....	53
------------------------------------	----

Parts lists.....	55
------------------	----

Specification.....	61
--------------------	----

Certificates

Declaration of conformity.....	63
--------------------------------	----

Keyword index.....	64
--------------------	----

Product information

Vitodens 100-W, WB1B

Set up for operation with natural gas.

Preparing for installation

Preparing the boiler installation

Dimensions and connections

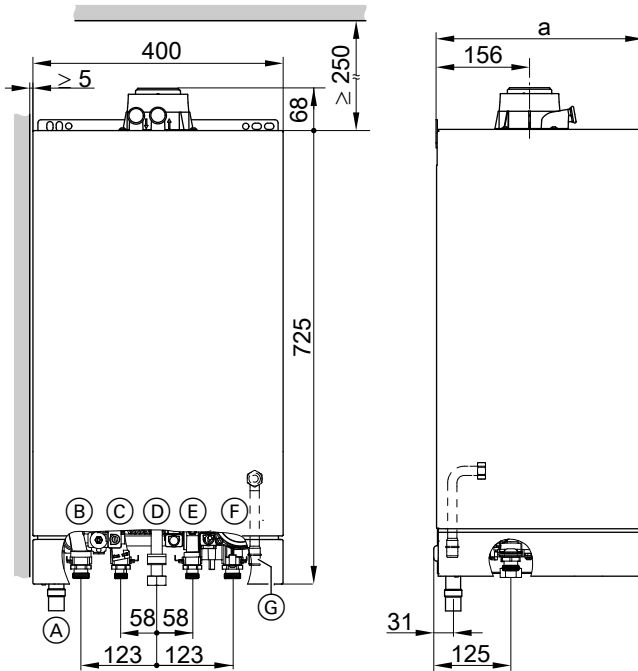

- (A) Condensate drain: Plastic pipe \varnothing 22 mm

(B) Heating flow
- (C) Gas fired condensing boiler: Cylinder flow
Gas fired condensing combi boiler: DHW

(D) Gas connection



Preparing for installation

Preparing for installation (cont.)

- Ⓔ Gas fired condensing boiler:
 - Cylinder return
 - Gas fired condensing combi boiler:
 - Cold water
- Ⓕ Heating return
- Ⓖ Drain safety valve

Rated output range	kW	9 - 26	11 - 30	11 - 35
a	mm	340	360	360

Preparing for installation (cont.)

Fitting the wall retainer

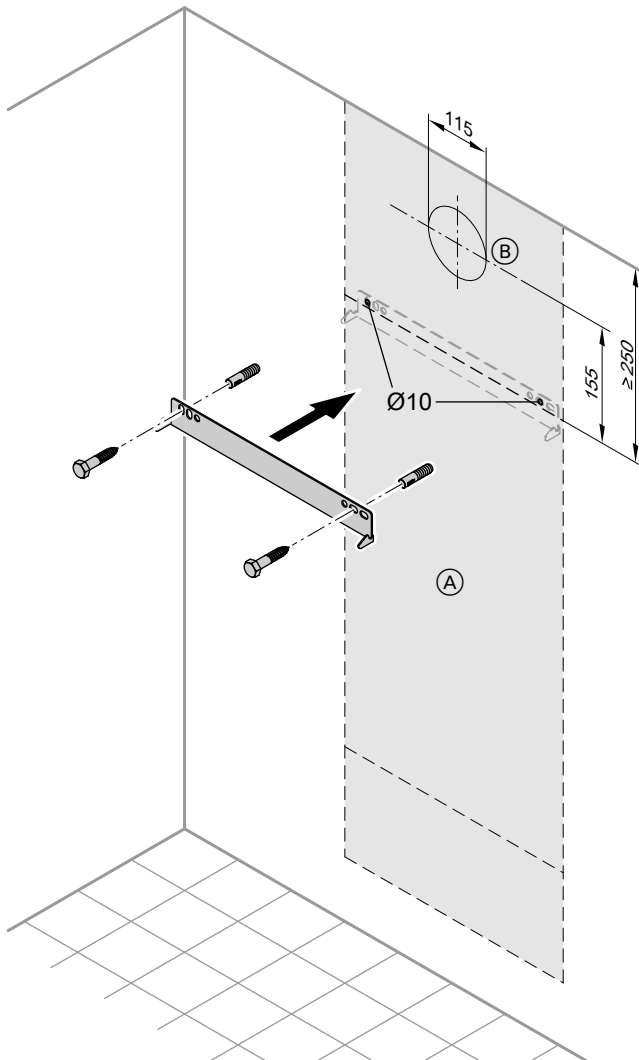

Ⓐ Installation template Vitodens

Ⓑ Opening for the balanced flue

1. Position the supplied installation template on the wall.

2. Mark out the rawl plug holes.



Preparing for installation

Preparing for installation (cont.)

3. Drill \varnothing 10 mm holes and insert the supplied rawl plugs.
 4. Fit wall retainer with screws supplied.
- Preparing the connections**
1. Prepare the water connections. Flush the heating system.
 2. Prepare gas connection.
 3. Prepare the electrical connections. Observe valid IEEE standards.
 - A 1.5 m long power cable is fitted as standard.
 - Accessory cables:
NYM-O 2-core min. 0.5 mm².

Installing the boiler and making all connections

Removing the front panel and mounting the boiler

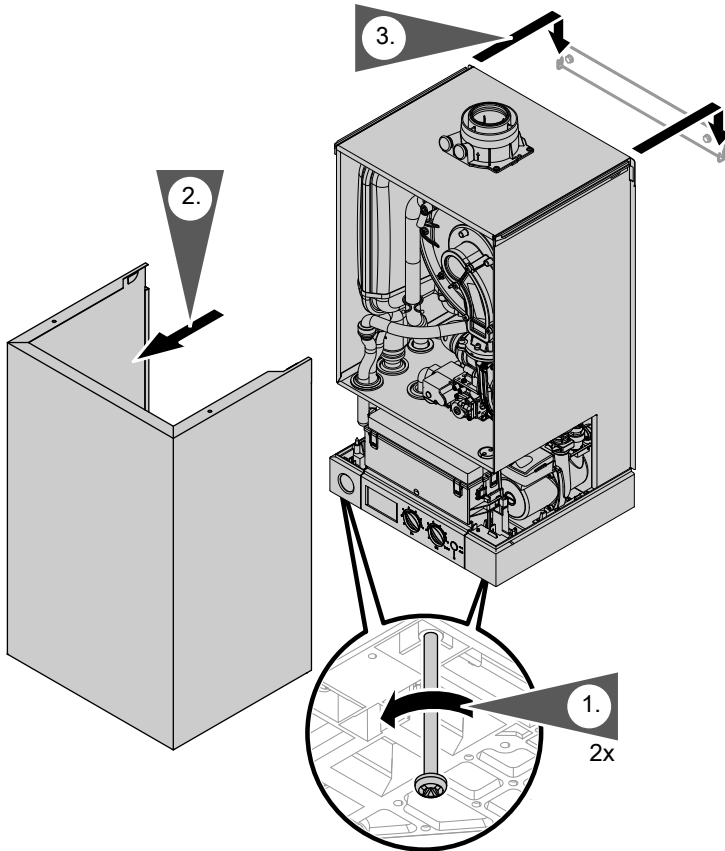

1. Release screws at the bottom of the boiler; do not remove completely.
2. Remove front panel.
3. Hook the boiler into the wall retainer.

Installing connections on the water side



For fittings on the heating water side and DHW side, see separate installation instructions.

Installation sequence

Installing the boiler and making all connections (cont.)

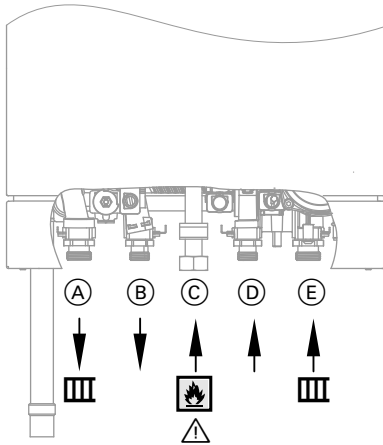

- (A) Heating flow
- (B) Gas fired condensing boiler:
Cylinder flow
Gas fired condensing combi boiler:
DHW
- (C) Gas connection
- (D) Gas fired condensing boiler:
Cylinder return
Gas fired condensing combi boiler:
Cold water
- (E) Heating return

Safety valve connection

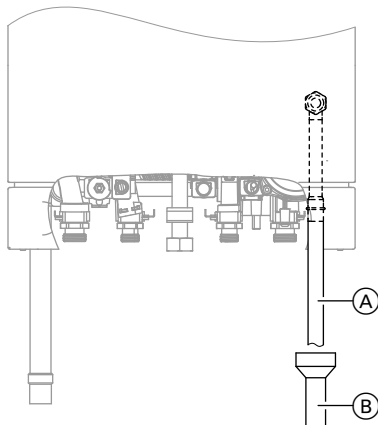

Connect safety valve drain (A) (\varnothing 15 mm) with visible outlet (B) to the dewatering system or route with visible outlet through the external wall.

Installing the boiler and making all connections (cont.)

Gas connection

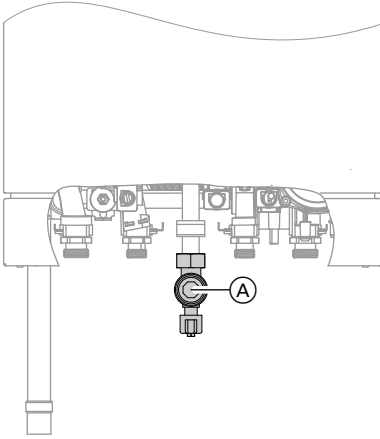

1. Connect gas shut-off valve to connection (A).
2. Carry out a leak/tightness test.



Please note

Excessive test pressure may damage the boiler and the gas valve.

Max. test pressure 150 mbar. Where higher pressure is required for tightness tests, separate the boiler and the gas valves from the gas supply pipe (undo the fitting).

3. Vent the gas supply pipe.

Installing the boiler and making all connections (cont.)

Condensate connection

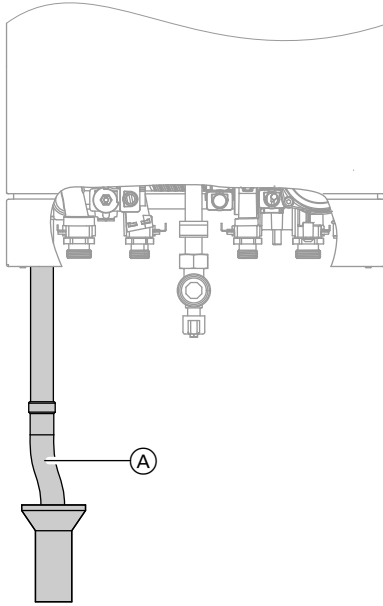

Connect condensate drain (A) with a slope and a pipe vent to the public sewer.
Observe the local waste water regulations.

Note

Fill the siphon with water before start-up.

Filling the siphon with water

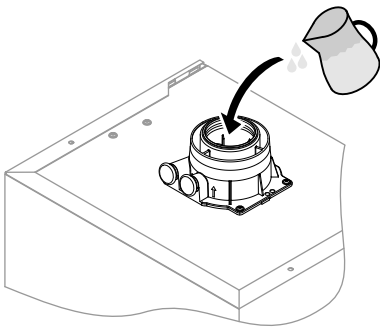

Fill a minimum of 0.3 l of water into the flue gas connection.



Please note

At commissioning, flue gas may be emitted from the condensate drain.

Fill the siphon with water before start-up.

Installing the boiler and making all connections (cont.)

Balanced flue connection

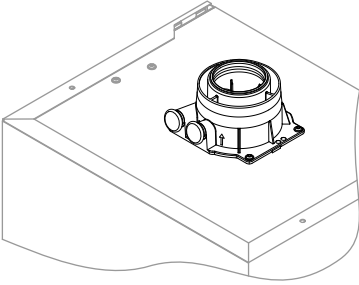

Connect the balanced flue.
During installation and positioning of the flue gas system, observe building regulations part L and BS 5440.



Flue gas system installation instructions.

Opening the control unit

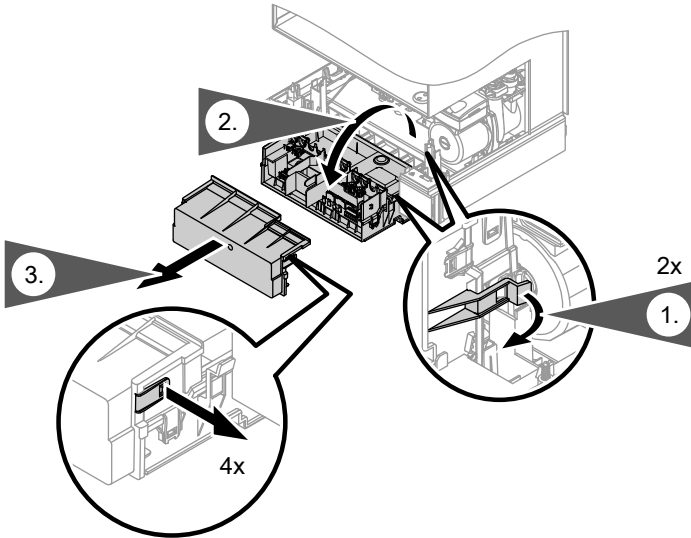

Opening the control unit (cont.)



Please note

Electronic modules can be damaged by electrostatic discharges.

Touch earthed objects, such as heating or water pipes, to discharge static loads.

Electrical connections



Information regarding the connection of accessories

For details of accessories, also observe their separate installation instructions provided.

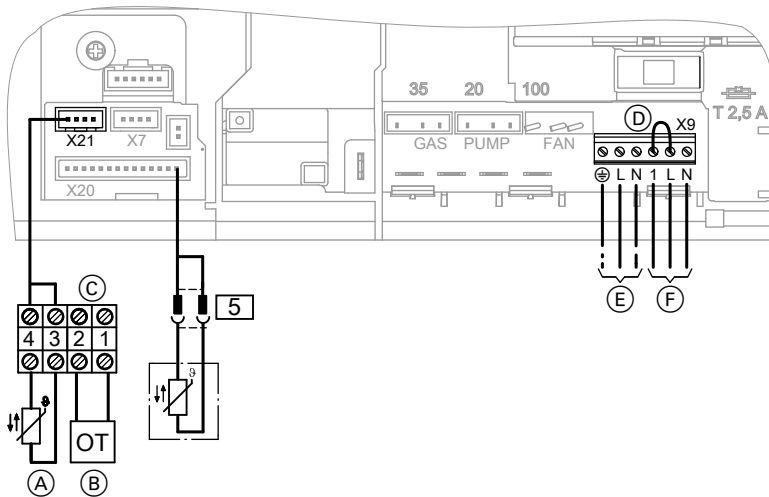

Electrical connections (cont.)

- 5 Gas fired condensing boilers only: Cylinder temperature sensor (plug on the cable harness outside the control unit) or connect the control box (supplied with the system boiler) if a 230V 2-port valve and cylinder stat are used in a 4-pipe installation (see separate installation instructions)
- 6 Power supply (230 V, 50 Hz).

**Danger**

Incorrect core termination can cause severe injuries and damage to the equipment.

Take care not to interchange wires "L1" and "N".

Note

Gas fired condensing boiler without DHW cylinder:

For operation without a DHW cylinder, set rotary selector "↻" to "0".

- A Only for weather-compensated mode:
Outside temperature sensor (accessory)
- B Open Therm device
- C Connection line (accessory)
- D Jumper (remove when connecting a room thermostat)
- F Vitotrol 100 (room temperature controller) or on-site room temperature controller



Separate installation instructions

or

Input for Y-plan or S-plan heating systems using gas fired condensing boilers

Outside temperature sensor (accessory)

1. Plug the power cable supplied with the outside temperature sensor into slot "X21".
2. Connect the outside temperature sensor to terminals 3 and 4.

NOTE: If an outside temperature sensor is used it is recommended not to install the system boiler to a 'Y' or 'S' plan heating system.

Electrical connections (cont.)

Routing connecting cables and closing control unit



Please note

Power cables will be damaged if they contact hot parts.
When routing and securing power cables on site, ensure that the maximum permissible temperatures for these cables are not exceeded.

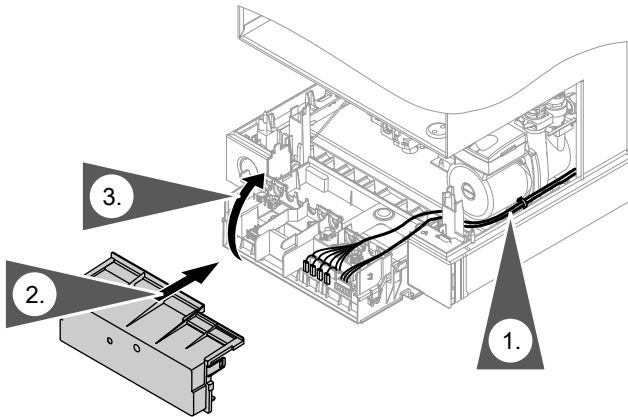

Steps - commissioning, inspection and maintenance

For further information regarding the individual steps, see the page indicated

				Page
			Commissioning steps	
			Inspection steps	
			Maintenance steps	
•	•	•	1. Filling the heating system.....	18
•	•	•	2. Venting the boiler by flushing out (after venting system).....	20
•			3. Adjusting circulation pump to suit heating system....	20
•	•	•	4. Changing to operation with LPG.....	21
•			5. Checking the CO₂ or O₂ content.....	22
	•	•	6. Burner removal	24
	•	•	7. Checking the burner gasket and the burner gauze assembly.....	25
	•	•	8. Checking and adjusting electrodes.....	26
	•	•	9. Cleaning the heat exchanger.....	26
	•	•	10. Checking the condensate drain and cleaning the siphon.....	28
	•	•	11. Burner installation	29
•	•	•	12. Checking all connections on the heating water side and DHW side for leaks	
•	•	•	13. Checking electrical connections for tightness	
•	•	•	14. Check gas equipment for tightness at operating pressure	30
	•	•	15. Fitting the front panel.....	30
•			16. Instructing the system user.....	31

Service

Further details regarding the individual steps

Filling the heating system



Please note

- Unsuitable fill water increases the level of deposits and corrosion and may lead to boiler damage.
 - Thoroughly flush the entire heating system prior to filling it with water.
 - Only use fill water of potable quality.
 - Soften fill water harder than 300 ppm.
 - An antifreeze additive suitable for heating systems can be mixed with the fill water.

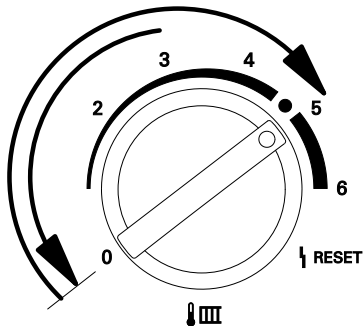

1. Close the gas shut-off valve.
2. Switch ON the power.
3. Turn rotary selector "III ↓" anticlockwise for less than 2 s and then clockwise back to the control range on the right.
Filling function is enabled. This function will end automatically after 20 min or after ON/OFF switch has been turned OFF.

Further details regarding the individual steps (cont.)

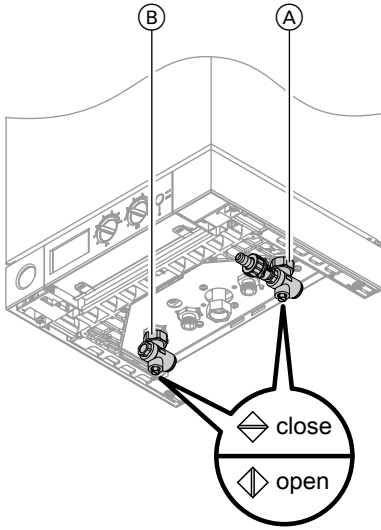

4. Open shut-off valves (A) and (if installed) (B).
5. Fill the heating system via an external filling facility. (Minimum system pressure > 0.8 bar).

Note

The external filling facility must meet the requirements of the Water Fittings Regulations 1999 Section G 24.1 and G 24.2.

Further details regarding the individual steps (cont.)

Venting the boiler by flushing out (after venting system)

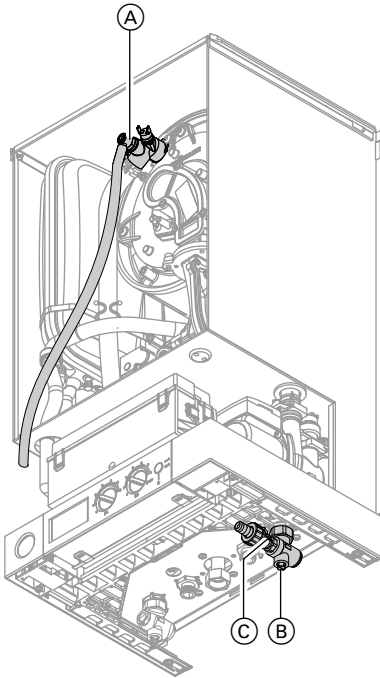

1. Connect the drain hose on shut-off valve (A) to a drain.
2. Close shut-off valve (B).
3. Open valves (A) and (C) and flush at mains pressure, until no sound of escaping air can be heard.
4. First shut off valve (A) then valve (C).
5. Operating pressure ≥ 0.8 bar; adjust with valve (C).
6. Open shut-off valve (B).

Adjusting circulation pump to suit heating system

Only for gas fired condensing combi boilers:

In the delivered condition, the circulation pump in heating mode is set to stage 1. If necessary to suit the heating system, the circulation pump can be adjusted to stage 2.

1. Turn ON/OFF switch ON.

Further details regarding the individual steps (cont.)

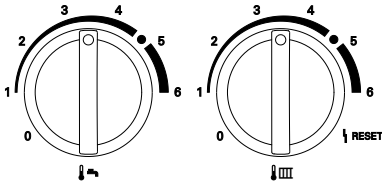

2. Simultaneously turn rotary selectors "🔥" and "💧" to their central position.
"SERV" appears on the display.

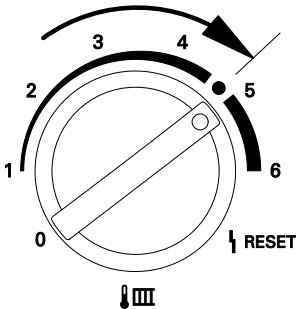

3. Within 2 s turn rotary selector "💧" to the top right area.
"💧" and the set value flash on the display.

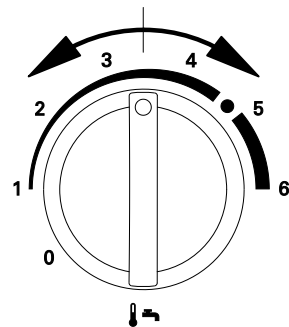

4. Adjust the control unit to stage 1 or 2 by turning rotary selector "🔥".
The display shows:
 - "1" for operation with stage 1
or
 - "2" for operation with stage 2
5. Do **not** adjust the rotary selectors for 15 s. The set operating mode is then saved and the control unit returns to standard mode.

Changing to operation with LPG

In the delivered condition, the boiler is set up for operation with natural gas. For operation with LPG, the gas nozzle must be changed and the gas type converted in the control unit.



Separate installation instructions.

Changing from LPG to natural gas - see page 49

Further details regarding the individual steps (cont.)

Checking the CO₂ or O₂ content

Vitodens 100-W is factory-set for natural gas. During commissioning or maintenance, the CO₂ and CO have to be measured at the boiler flue adaptor test-point to check the flue integrity. Subject to the Wobbe index, the CO₂ content fluctuates between 7.4 % and 10.5 %. And CO of up to 500 ppm is acceptable.

We recommend to measure O₂ as the value is unmistakable regarding lambda (air/gas). The O₂-content fluctuates between 7.5 % and 3.2 %. The CO/CO₂ ratio has to be less than 0,008.

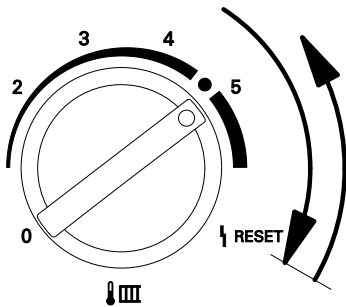
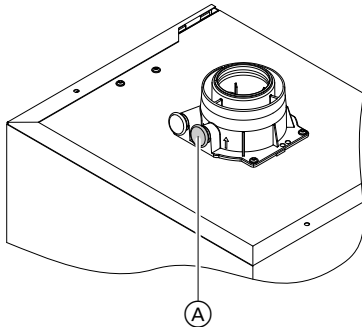

If the actual CO₂ or O₂ and CO values deviate from the stated range, check the balanced flue systems for leaks. If flue installation is OK, change the gas valve.

1. Connect a flue gas analyser at flue gas port (A) on the boiler flue connection.

2. Start the boiler.

3. Turn rotary selector "↓ III" clockwise for less than 2 s and then anticlockwise back to the control range on the right.

The display shows "SERV" and the boiler water temperature is shown.

Further details regarding the individual steps (cont.)

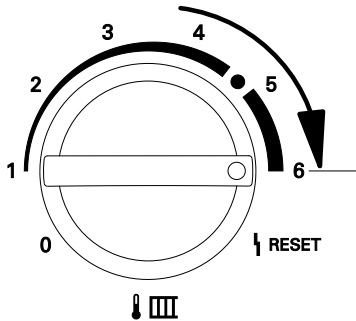

4. Adjust the upper output:
Turn rotary selector "🌡️ IIII" to the control range on the right.
The display shows 5 bars for upper output.

5. Measure the CO₂ content for upper output.
The CO₂ content must be between 7.4 and 10.5 %.

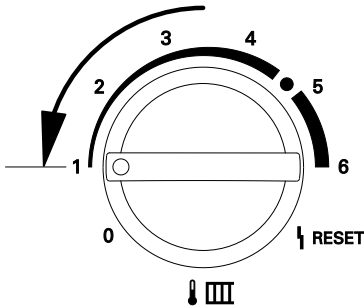

6. Adjust the lower output:
Turn rotary selector "🌡️ IIII" to the left control range.
The display shows 1 bar for lower output.

7. Test the CO₂ content for lower output.
The CO₂ content must be between 7.4 and 10.5 %.

8. If the CO₂ content is **not** within the given range, check the flue gas/ventilation air system for tightness.
Remedy any leaks.

9. Shut the boiler down, remove flue gas analyser and close flue gas port (A).

Further details regarding the individual steps (cont.)

Burner removal

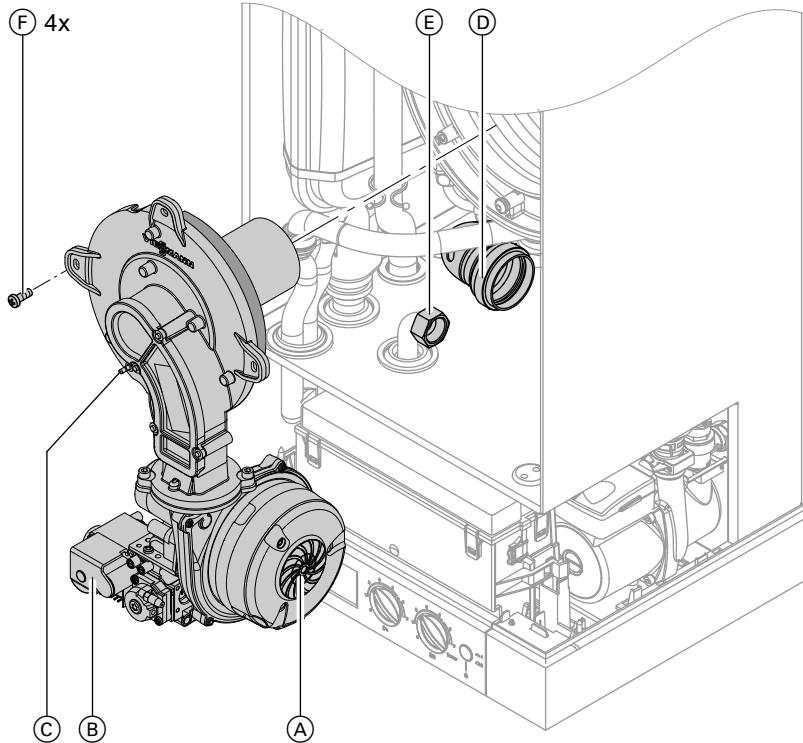

1. Switch OFF the power.
2. Shut off the gas supply.
3. Pull power cables from fan motor (A), gas valve (B) and electrodes (C).
4. Pull the venturi extension (D) from the fan.
5. Release gas supply pipe (E) fitting.
6. Undo four screws (F) and remove the burner.

! **Please note**
To prevent damage,
never rest the burner on the
gauze assembly.

Further details regarding the individual steps (cont.)

Checking the burner gasket and the burner gauze assembly

Check burner gasket (A) for damage and replace if required.

Replace the burner gauze assembly if it is damaged.

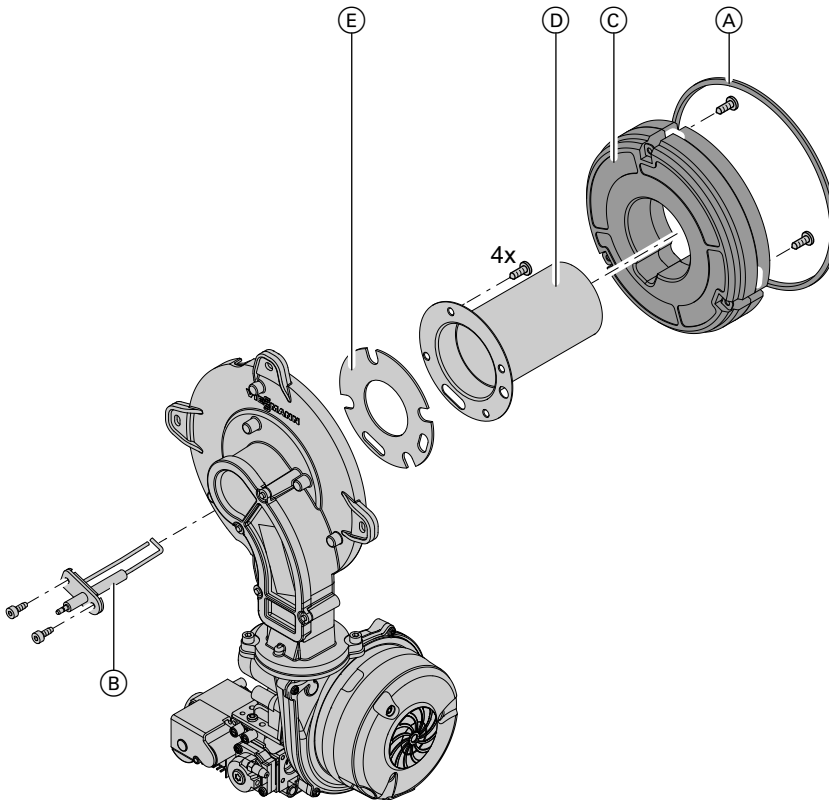

1. Remove electrode (B).
2. Undo the three cheese-head screws and remove thermal insulating ring (C).
3. Undo four Torx screws and remove burner gauze assembly (D) with its gasket (E).
4. Insert and secure a new burner gauze assembly (D) with a new gasket (E).
Fixing screw torque: 3.5 Nm.



Further details regarding the individual steps (cont.)

5. Refit thermal insulation ring (C).
Fixing screw torque: 3.5 Nm.
6. Refit the electrode (B).
Fixing screw torque: 3.5 Nm.

Checking and adjusting electrodes

1. Check the electrode for wear and contamination.
2. Clean the electrode with a small brush (not with a wire brush) or emery paper.
3. Check the electrode gaps. If the gaps are not as specified or the electrode is damaged, replace and align the electrode together with a new gasket. Tighten the electrode fixing screws with 3.5 Nm.

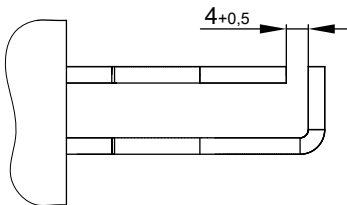
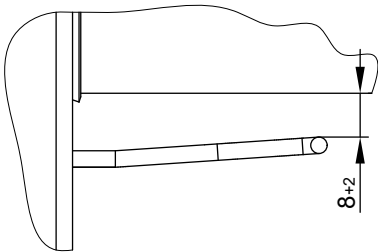

Cleaning the heat exchanger

- ! **Please note**
Scratches on parts that are in contact with flue gas can lead to corrosion.
Never use brushes to clean the heat exchanger.

Further details regarding the individual steps (cont.)

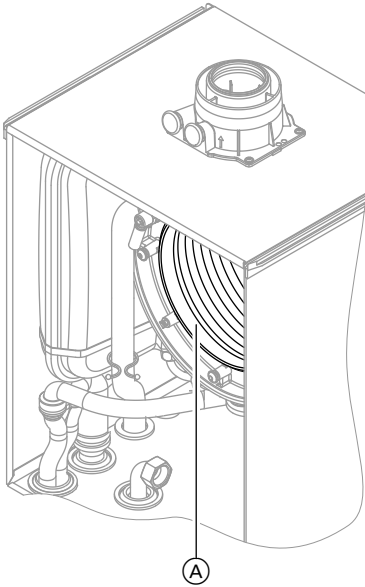

1. Use a vacuum cleaner to remove residues from the heat exchanger (A) inside the combustion chamber.
2. If required, spray slightly acidic, chloride-free cleaning agents based on phosphoric acid onto heat exchanger (A) and let the solution soak in for approx. 20 min.
3. Thoroughly flush the heat exchanger (A) with water.

Further details regarding the individual steps (cont.)

Checking the condensate drain and cleaning the siphon

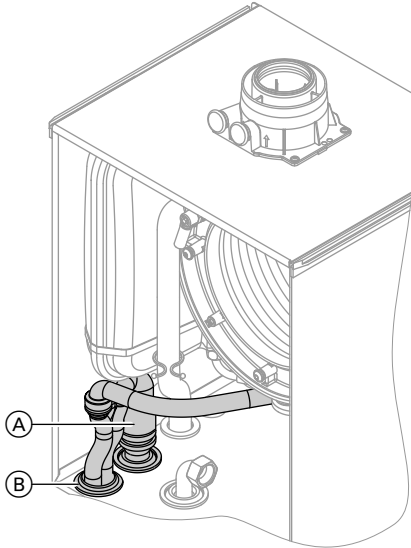

1. Check that the condensate can drain freely at the siphon.
2. Remove all hoses from siphon (A).
3. Release locking tabs at opening (B) from underneath and remove siphon (A) upwards.
4. Clean siphon (A) and reinstall.
5. Refit all hoses. Secure drain hose with cable ties.
6. Fill siphon (A) with water. by pouring about 0.3 l of water into the combustion chamber.

Further details regarding the individual steps (cont.)

Burner installation

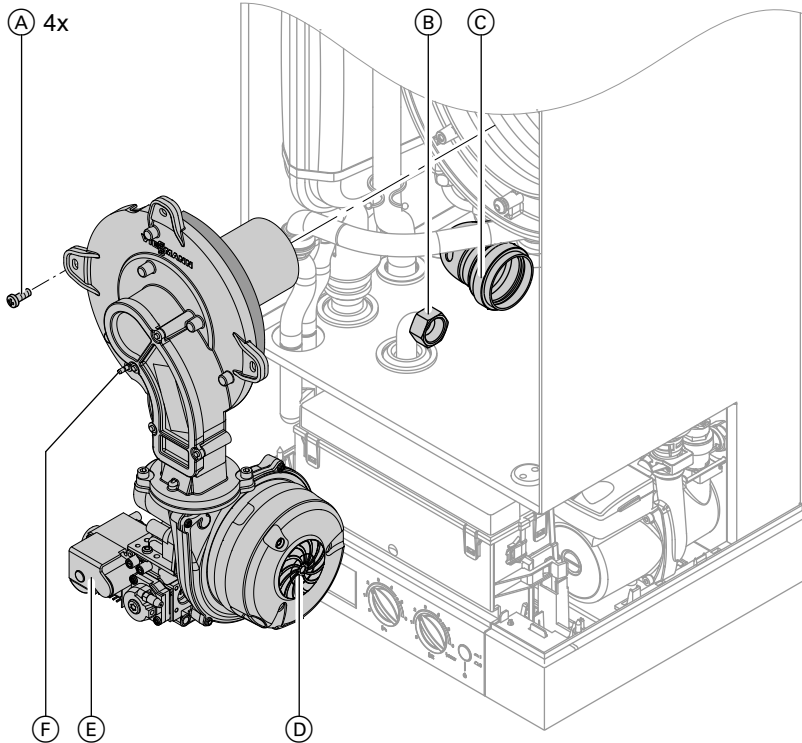

1. Install the burner and torque screws (A) diagonally with 4.0 Nm.
2. Insert new gasket and tighten the fittings on gas supply pipe (B)
3. Plug the venturi extension (C) into the fan.
4. Replace electrical cables from fan motor (D), gas valve (E) and ignition unit (F).
5. Reopen gas supply and switch on power supply.
6. Check the gas connections for tightness.



Danger

Escaping gas leads to a risk of explosion.
Check all fittings for gas-tightness.

Further details regarding the individual steps (cont.)

Check gas equipment for tightness at operating pressure



Danger

Escaping gas leads to a risk of explosion.
Check gas equipment for tightness.

Fitting the front panel

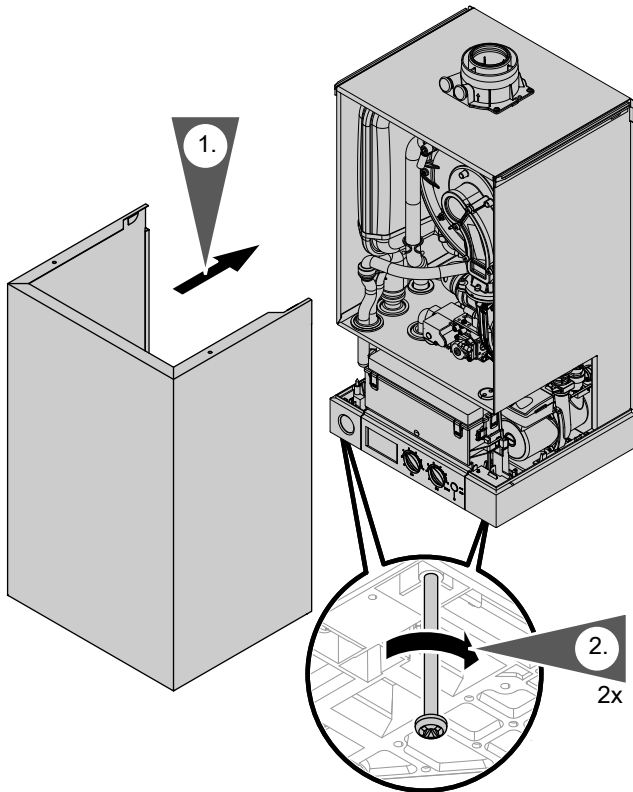

1. Push front panel into place on the guide rails.

2. Tighten screws at the bottom.

Further details regarding the individual steps (cont.)

Instructing the system user

The system installer must hand the operating instructions to the system user and instruct him/her in the operation of the system.

Function sequence and possible faults

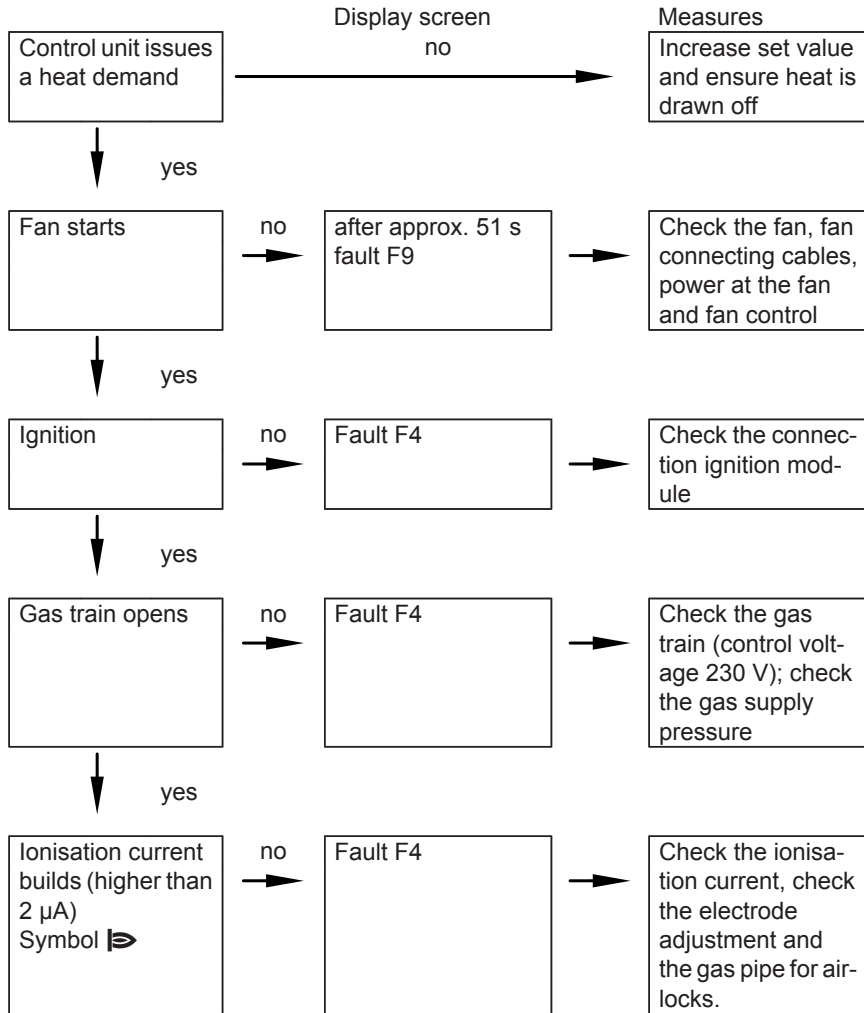

Function sequence and possible faults (cont.)

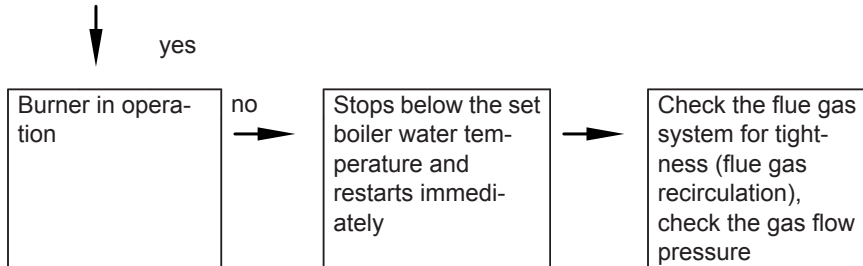

Fault messages on the display

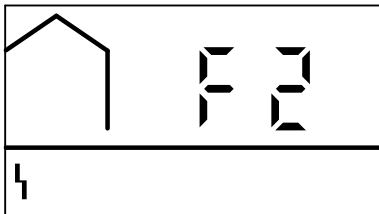

Faults are indicated by a flashing fault code with fault symbol "⚡" on the display.
For fault code explanations see the following table.

Fault code on the display	System characteristics	Cause	Measures
10	Constant mode	Short circuit, outside temperature sensor	Check the outside temperature sensor and lead (see page 37).
18	Constant mode	Break, outside temperature sensor	Check the outside temperature sensor and lead (see page 37).
30	Burner blocked	Short circuit, boiler water temperature sensor	Check the boiler water temperature sensor (see page 39).
38	Burner blocked	Break, boiler water temperature sensor	Check the boiler water temperature sensor (see page 39).
50	No DHW heating	Cylinder temperature sensor shorted out	Check the sensor (see page 40).



Fault messages on the display (cont.)

Fault code on the display	System characteristics	Cause	Measures
51	No DHW heating	Outlet temperature sensor shorted out	Check the sensor (see page 43).
52	Burner blocked	Short circuit, flow sensor	Check connections and lead; replace sensor if required.
58	No DHW heating	Cylinder temperature sensor lead broken	Check the sensor (see page 40).
59	No DHW heating	Outlet temperature sensor lead broken	Check the sensor (see page 43).
5A	Burner blocked	Break, flow sensor	Check connections and lead; replace sensor if required.
A9	Regulated operation without Open Therm device	Communication fault Open Therm device	Check connections and lead; replace Open Therm device if required.
b0	Burner blocked	Short circuit, flue gas temperature sensor	Check the sensor (see page 44).
b8	Burner blocked	Break, flue gas temperature sensor	Check the sensor (see page 44).
E5	Burner blocked	Internal fault	Check the ionisation electrode and cables. Press "Reset" (see page 36).
F0	Burner blocked.	Internal fault	Replace the control unit.
F1	Burner in a fault state	Max. flue gas temperature exceeded	Check the heating system fill level. Check the circulation pump. Vent the system. Press "Reset" (see page 36).

Fault messages on the display (cont.)

Fault code on the display	System characteristics	Cause	Measures
F2	Burner in a fault state	The temperature limiter has responded	Check the heating system fill level. Check the circulation pump. Vent the system. Check the temperature limiter and connecting cables. Press "Reset" (see page 36).
F3	Burner in a fault state	Flame signal is already present at burner start	Check the ionisation electrode and connecting cable. Press "Reset" (see page 36).
F4	Burner in a fault state	No flame signal is present	Check the ionisation electrode and leads, measure the ionisation current, check the gas pressure, check the gas train, ignition, ignition module and condensate drain. Press "Reset" (see page 36).
F8	Burner in a fault state	The fuel valve closes too late	Check the gas train. Check both control paths. Press "Reset" (see page 36).
F9	Burner in a fault state	Fan speed too low during the burner start	Check the fan, check the fan cables and supply; check the fan control. Press "Reset" (see page 36).
FA	Burner in a fault state	Fan not at standstill	Check the fan, fan connecting cables and fan control. Press "Reset" (see page 36).
FC	Burner blocked	Electrical fan control (control unit) faulty	Check fan connecting cable; if required, replace or replace control unit

5366 636 GB

Service



Fault messages on the display (cont.)

Fault code on the display	System characteristics	Cause	Measures
Fd	Burner blocked	Burner control unit fault	Check ignition electrodes and connecting cables. Check whether a strong interference (EMC) field exists near the equipment. Press "Reset" (see page 36). Replace control unit if the fault persists.
FF	Burner blocked	Burner control unit fault	Check ignition electrodes and connecting cables. Check whether a strong interference (EMC) field exists near the equipment. Press "Reset" (see page 36). Replace control unit if the fault persists.

Press reset

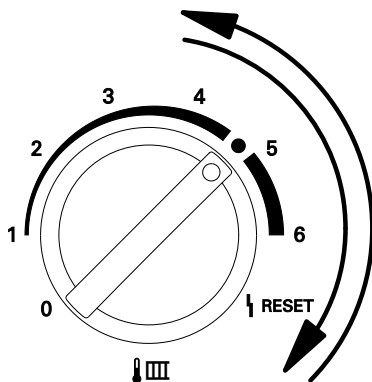

Turn rotary selector "III" less than 2 s to "RESET", then back to the control range.

Repairs

Removing front panel

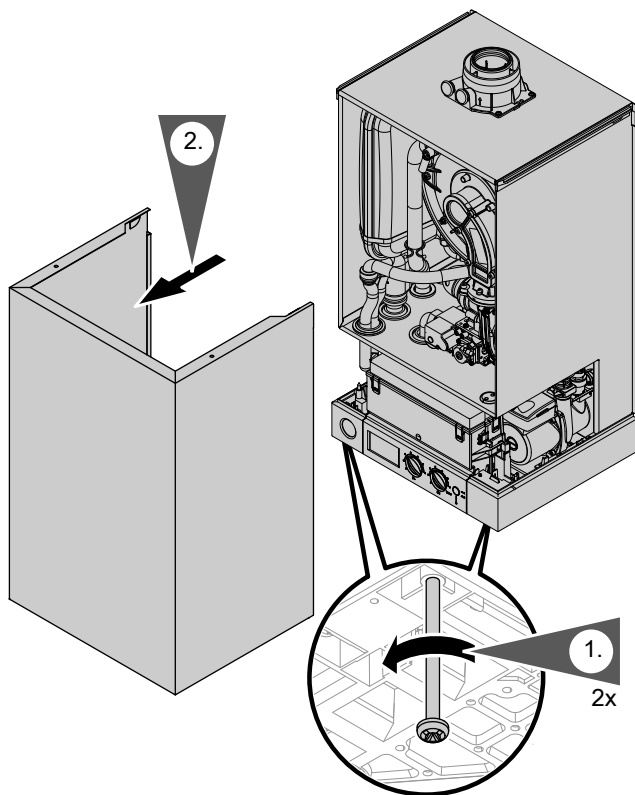

- 1. Release screws at the bottom of the boiler; do not remove completely.
- 2. Remove front panel.

Outside temperature sensor

- 1. Open the control unit casing. See page 13.

Service



Troubleshooting

Repairs (cont.)

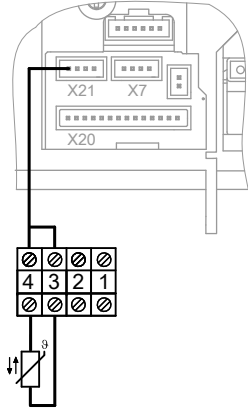

2. Disconnect cables from outside temperature sensor.

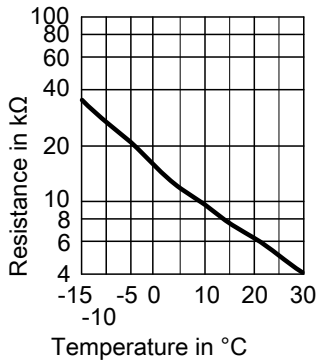

3. Check the sensor resistance and compare it with the curve.
4. Replace the sensor in case of severe deviation.

Repairs (cont.)

Boiler water temperature sensor

1. Pull the leads from boiler water temperature sensor (A) and check the resistance.

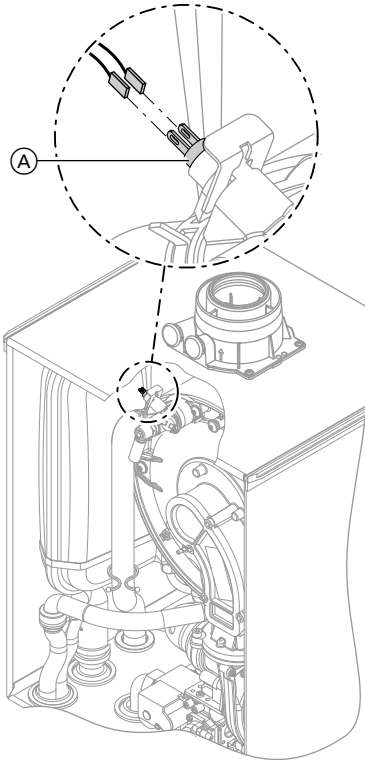

Repairs (cont.)

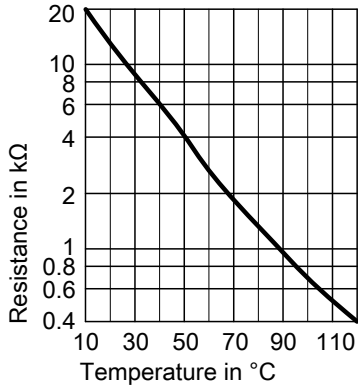

2. Check the sensor resistance and compare it with the curve.
3. In case of severe deviation, drain boiler on the heating water side and replace the sensor.



Danger

The boiler water temperature sensor is immersed in the heating water (risk of scalding).

Drain the boiler before replacing the sensor.

Checking cylinder temperature sensor (gas fired condensing boiler)

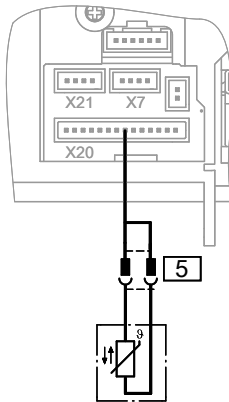

1. Remove plugs **5** from the cable harness and check the resistance.

Repairs (cont.)

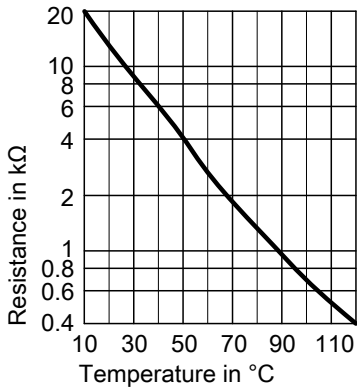

2. Compare the sensor resistance with the curve.
3. Replace the sensor in case of severe deviation.

Checking the temperature limiter

If the burner control unit cannot be reset after a fault shutdown, although the boiler water temperature is below approx. 95 °C, check the temperature limiter.



Repairs (cont.)

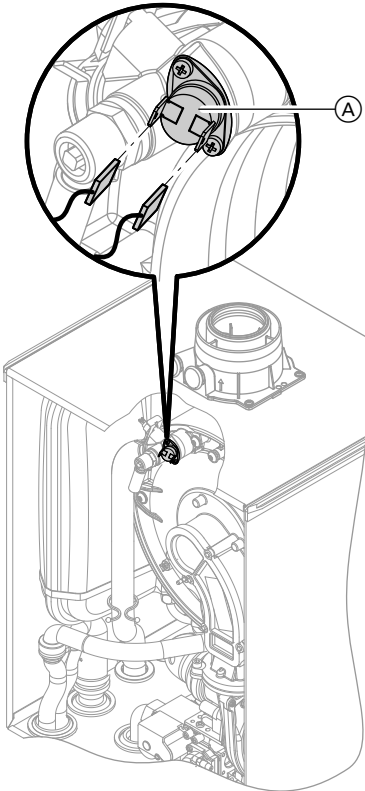

1. Pull the leads from temperature limiter (A).
2. Check the continuity of the temperature limiter with a multimeter.
3. Remove the faulty temperature limiter.
4. Install a new temperature limiter.
5. Press "Reset" at the control unit (see page 36).

Repairs (cont.)

Checking the outlet temperature sensor (gas fired condensing combi boiler)

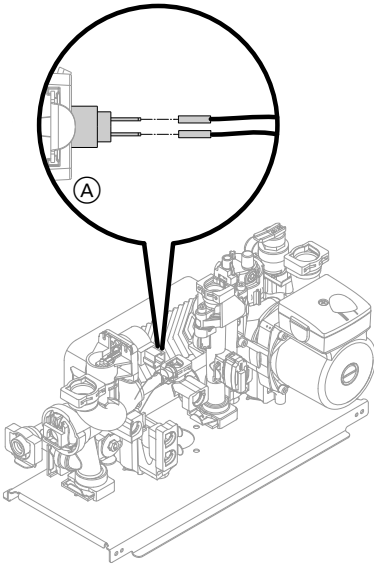

1. Pull the leads from outlet temperature sensor (A)
2. Check the sensor resistance and compare it with the curve.

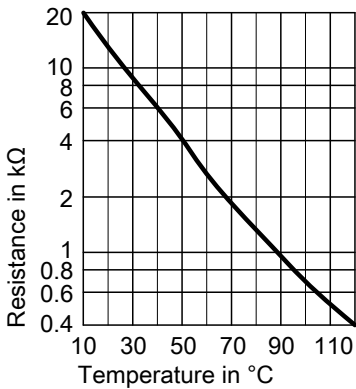

3. Replace the sensor in case of severe deviation.

Note

Water can leak when replacing the outlet temperature sensor. Shut off the cold water supply. Drain the DHW line and the plate-type heat exchanger (DHW side).

Repairs (cont.)

Checking the flue gas temperature sensor

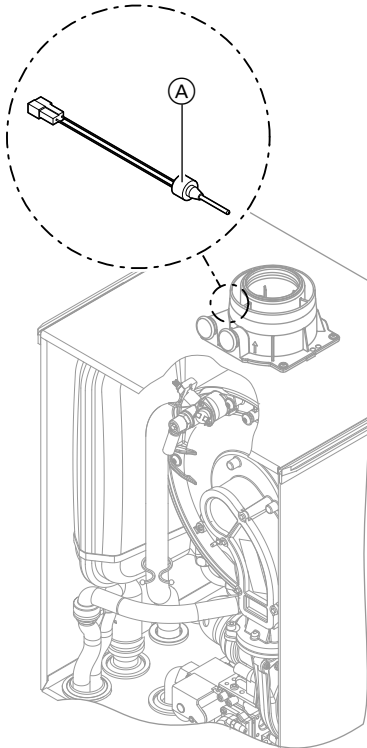

1. Pull the leads from flue gas temperature sensor (A).
2. Check the sensor resistance and compare it with the curve.

Repairs (cont.)

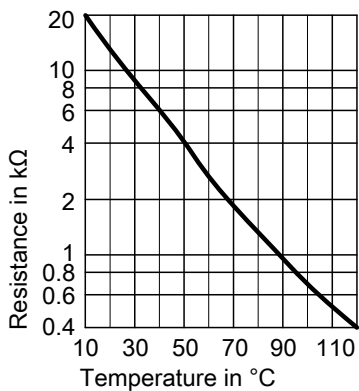

3. Replace the sensor in case of severe deviation.

Replacing flow limiter (gas fired condensing combi boiler)

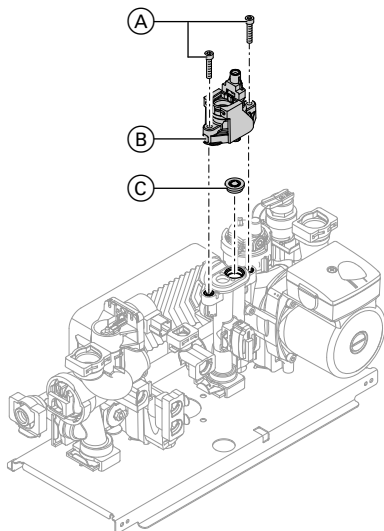

1. Drain the boiler from the DHW side.
2. Pivot the control unit downwards.
3. Undo screws (A).
4. Remove the cap (B).
5. Remove faulty flow limiter (C).
6. Select new flow limiter (C) corresponding to boiler serial no. (see type plate) and the following table.
7. Insert new flow limiter (C).
8. Fit new cap (B) provided.

Repairs (cont.)

Serial number (Type plate)	Flow rate l/min	Colour
7373 061	10	black
7373 063	12	red
7373 065	14	brown

Checking or replacing the plate-type heat exchanger (gas fired condensing combi boiler)

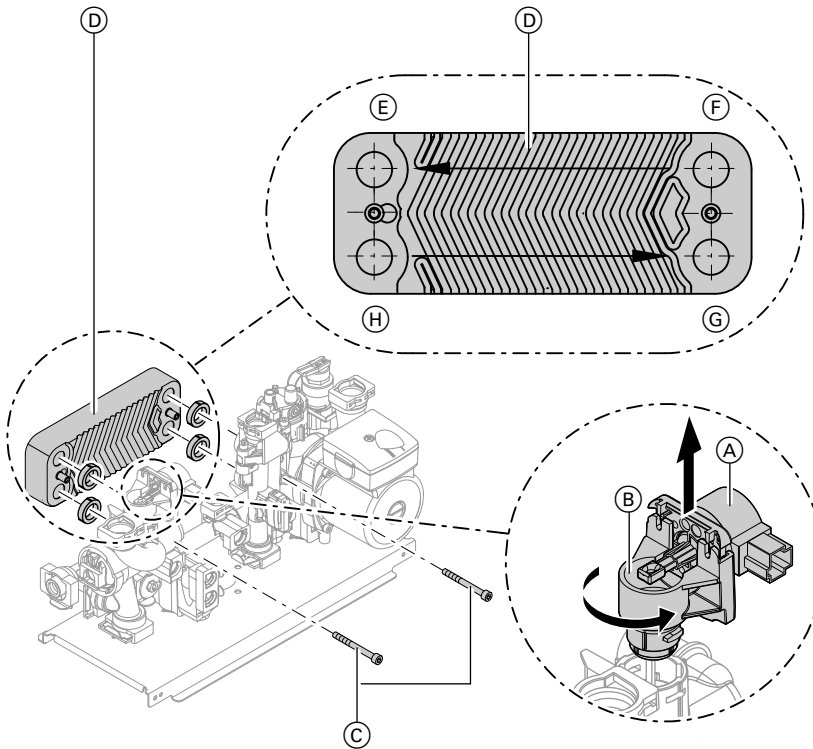

- (E) Heating water flow
- (F) Heating water return

- (G) Cold water
- (H) DHW

1. Shut off and drain the boiler on the heating water and the DHW side.
2. Flip down control unit.

Repairs (cont.)

3. Push the three-way valve drive (A) slightly upwards.
4. Turn the three-way valve (B) with drive (A) 1/8 anticlockwise and remove.
5. Remove two screws (C) from the plate-type heat exchanger and remove plate-type heat exchanger (D) with gaskets.
6. Check the DHW side for scaling and, if required, clean or replace the plate-type heat exchanger.
7. Check the heating water side for contamination and, if required, clean or replace the plate-type heat exchanger.
8. Install in reverse order with new gaskets.

Note

During removal, small amounts of water may trickle out and escape from the removed plate-type heat exchanger.

Note

Ensure that fixing holes and gaskets are aligned. Install the heat plate exchanger the correct way round.

Checking the fuse

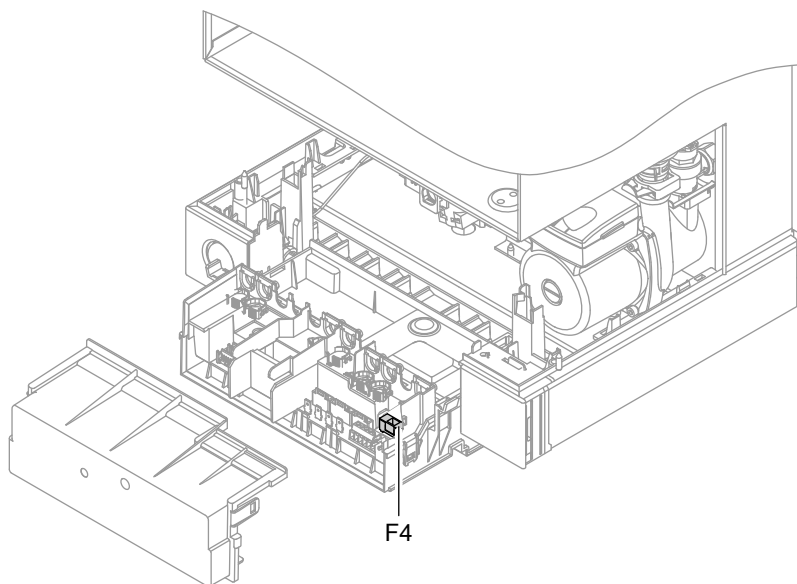

1. Switch OFF the power.
2. Open control unit casing (see page 13).



Troubleshooting

Repairs (cont.)

3. Check fuse F4.

Converting from LPG to natural gas

Removing gas restrictor

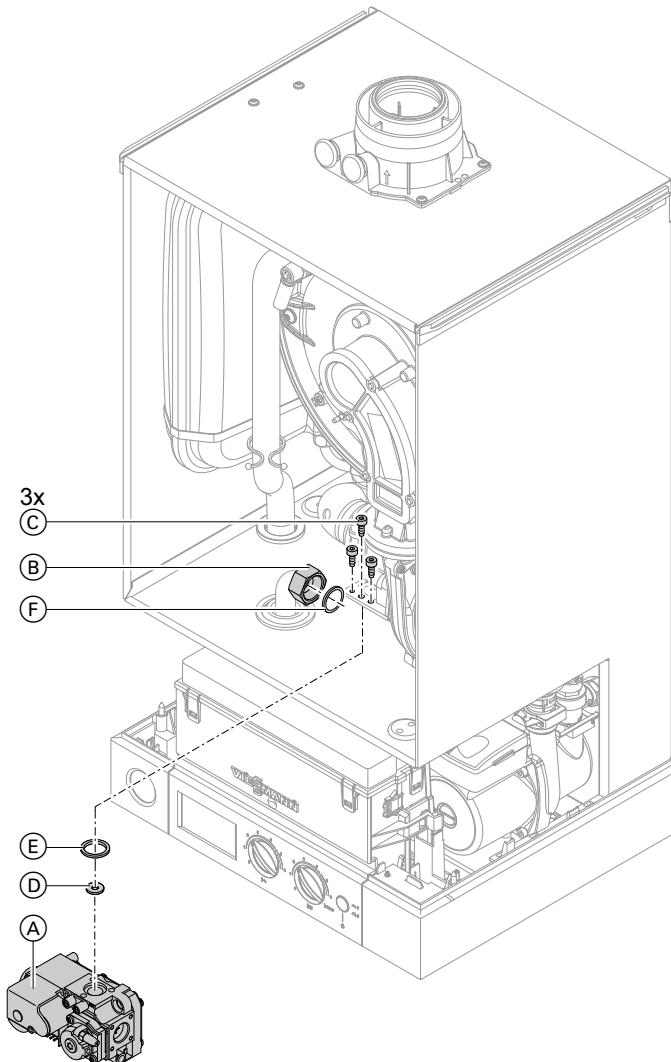

1. Pull power cable from gas train (A).
2. Remove union nut (B).
3. Undo three screws (C) and remove gas train (A).

5366 636 GB

Service



Gas type conversion

Converting from LPG to natural gas (cont.)

4. Remove gas restrictor (D) from gas train.
5. Fit gas train (A) with new gaskets (E) and (F).
Fixing screw torque (C): 3 Nm.
Union nut torque (B): 22 Nm.
6. Remove or void gas type sticker on the top of the boiler (next to the type plate).

Converting gas type on the control unit

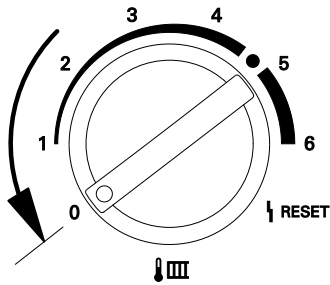
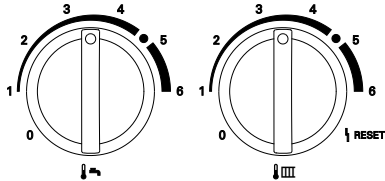

1. Turn ON/OFF switch ON.
2. Simultaneously turn rotary selectors "1" and "3" to their central position.
"SERV" appears on the display.
3. Turn rotary selector "3" anticlockwise within 2 s.
"1" and the set value flash on the display.

Converting from LPG to natural gas (cont.)

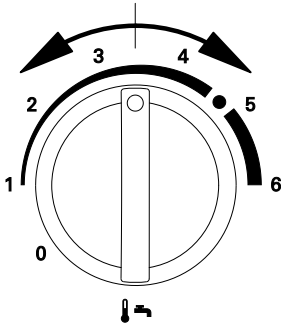

4. Adjust the control unit to natural gas or LPG by turning the rotary selector "⏻".

The display shows:

- "0" for operation with natural gas
or
- "1" for operation with LPG.

5. Do **not** adjust the rotary selectors for 15 s. The set operating mode is then saved and the control unit returns to standard mode.

Checking the CO₂ content

See page 22.

Functions and operating conditions in weather-compensated mode

In weather-compensated mode, the boiler water temperature is regulated subject to the outside temperature.

Heating curve of weather-compensated control unit

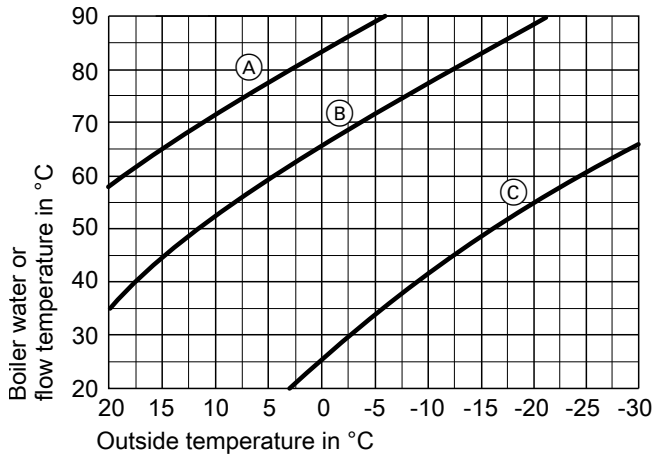

- Ⓐ Rotary selector "📉" setting: 6
- Ⓑ Delivered condition

- Ⓒ Rotary selector "📉" setting: 1

Frost protection function

The frost protection is generally active when the boiler is in 'Stand-by' mode. If the boiler temperature is less than 8°C the circulating pump is ON and at a boiler temperature of 12°C the pump is OFF.

The burner will be switched on at a boiler temperature of 5°C and switched off at 15°C.

Connection and wiring diagram

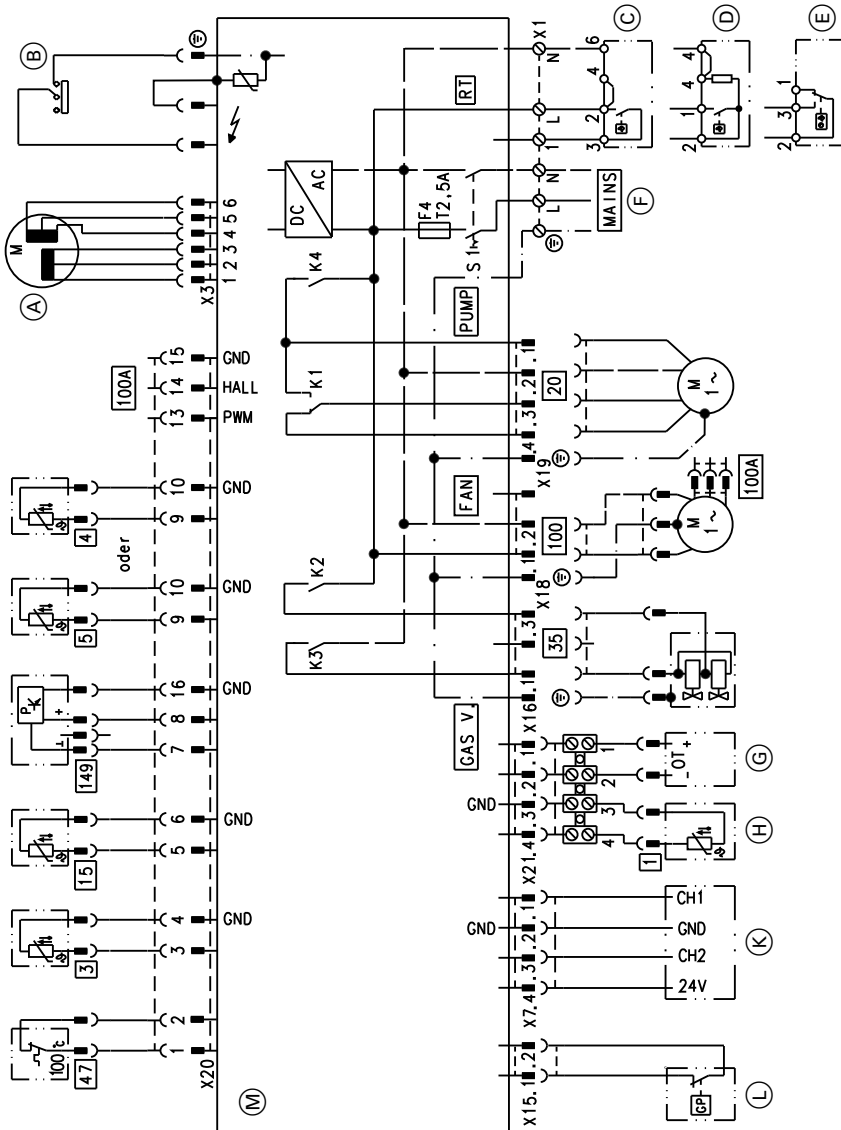

53866 636 GB

- (A) Stepper motor diverter valve
- (B) Ignition/Ionisation

- (C) Vitotrol 100, type UTA or on-site room temperature controller



Service

Designs

Connection and wiring diagram (cont.)

Ⓓ	Vitotrol 100, type RT or on-site room temperature controller	3	Boiler water temperature sensor
Ⓔ	Vitotrol 100, type UTD or on-site room temperature controller	4	Outlet temperature sensor (gas fired condensing combi boiler)
Ⓕ	Mains input 230V/50Hz	5	Cylinder temperature sensor (gas fired condensing boiler)
Ⓖ	Remote control (accessory)	15	Flue gas temperature sensor
Ⓕ	Outside temperature sensor (accessory)	20	Circulation pump 230V~
Ⓚ	Time switch (accessories)	35	Gas solenoid valve
Ⓛ	Gas pressure limiter (accessory)	47	Temperature limiter
Ⓜ	PCB inside the control unit	100	Fan motor 230V~
X ...	Electrical interface	100A	Fan control
		149	Flow sensor

Parts lists

When ordering spare parts:

Quote the part and serial no. (see type plate) and the item number of the required part (as per this parts list).

Obtain standard parts from your local supplier.

001 Heat exchanger	040 Clip Ø 10
002 Moulded hose heating water flow	041 Clip Ø 13.5
003 Moulded hose heating water return	042 Clip Ø 16
004 Hose connector adapter	043 Clip Ø 18
005 Heating water return connection elbow	044 Clip SIV (5 pce.)
006 Heating water flow connection elbow	047 O-ring Ø 17 x 4 (5 pce.)
007 Gas supply pipe	048 Expansion tank
009 Pressure gauge	050 Burner gasket
010 Boiler flue connection	051 Insulation ring
011 Drain valve	052 Burner gauze assembly
012 Siphon	053 Burner gauze assembly gasket
013 Flue gas gasket	055 Gasket ignition and ionisation electrode (5 pce.)
014 Diaphragm expansion vessel	056 Fan
015 Connection line; diaphragm expansion vessel	057 Gas valve (G 20/G 25)
016 Boiler flue connection plug	058 Burner door
017 Thermal insulation block	061 Venturi extension
018 Condensate hose	062 Gasket burner flange
019 Condensate hose 400 mm	070 Control unit
020 Ventilation air gasket	071 Cover – wiring chamber
021 Guide rails (set)	072 Thermocouple
023 Safety valve	073 Boiler water temperature sensor
027 Hose clip DN 25	074 Flue gas temperature sensor
029 Hydraulics	083 Outlet temperature sensor
030 Circulation pump motor	100 Front panel
031 Plate-type heat exchanger	101 Control flap
032 Plate-type heat exchanger gasket set	105 Wall retainer
033 Linear stepper motor	
034 Flow sensor	Wearing parts
035 Air vent valve	054 Ignition and ionisation electrode
036 Flow limiter	
037 Bypass cartridge with check valve	Parts not shown
039 Clip Ø 8	059 Conversion kit G 31
	075 Cable harness X20 (gas fired condensing combi boiler)
	076 Cable harness X20 (gas fired condensing boiler)
	077 Gas solenoid valve connecting cable 35
	078 Fan connecting cable 100
	079 Ignition cable
	080 Cable harness stepper motor
	081 Fuse 2.5 A (slow) (10 pce.)



Parts lists

Parts lists (cont.)

- | | |
|-------------------------------------|---|
| 082 Cable fixing | 110 Installation and service instructions |
| 102 Spray paint, Vitowhite | 111 Operating instructions |
| 103 Touch-up paint stick, Vitowhite | Ⓐ Type plate |
| 104 Special grease | |

Parts lists (cont.)

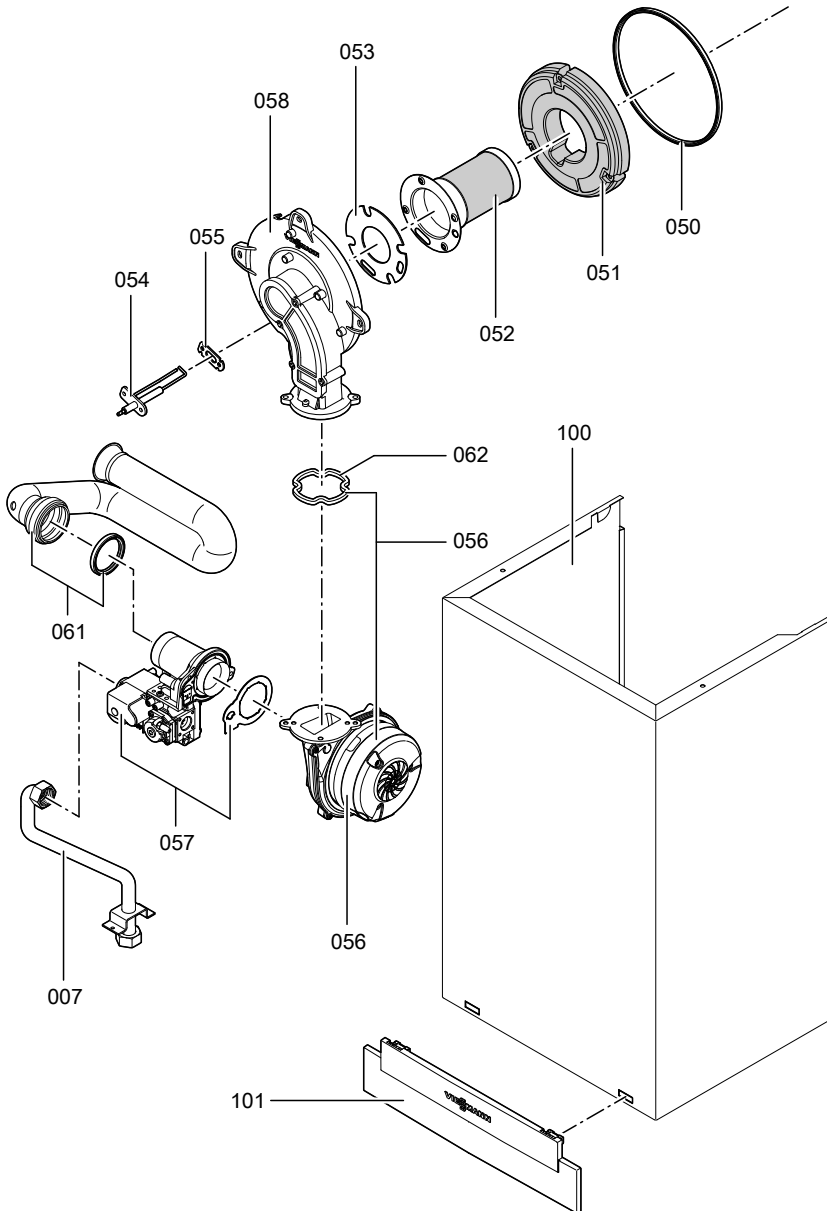

53866 836 GB

Service

Parts lists

Parts lists (cont.)

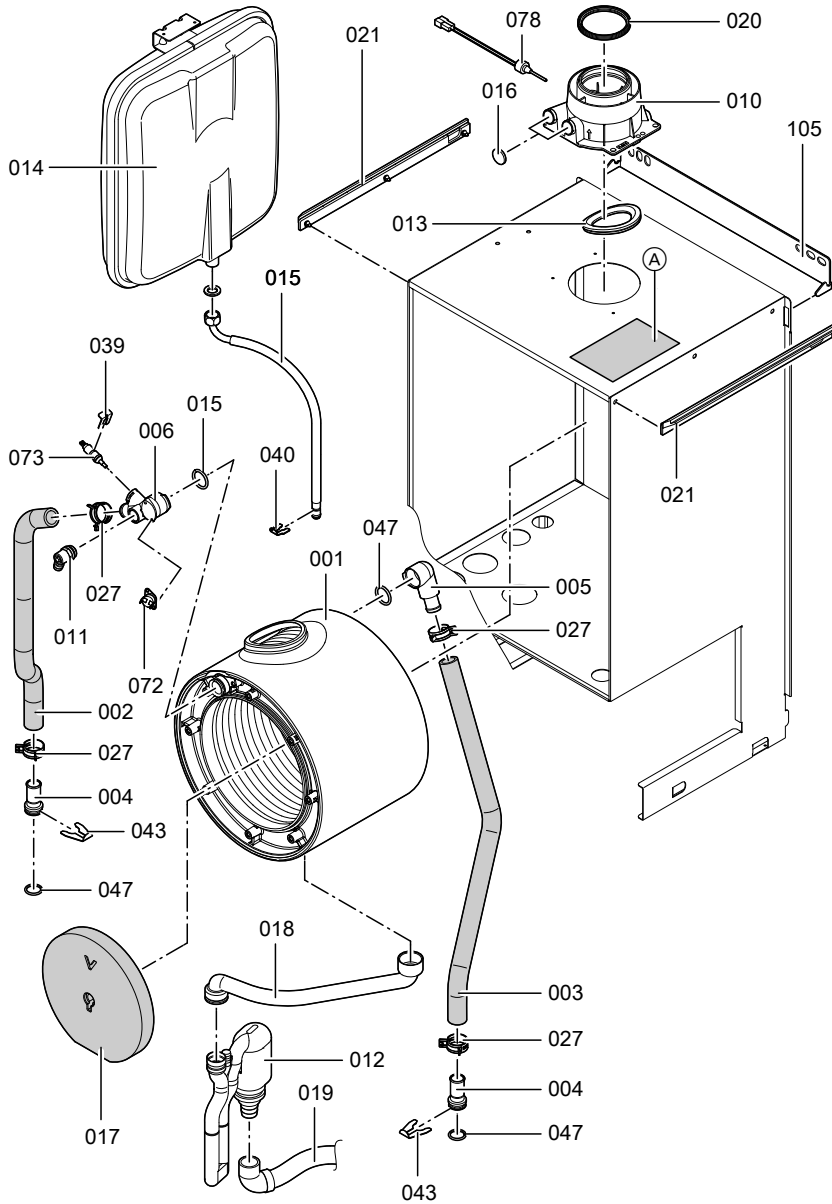

Parts lists (cont.)

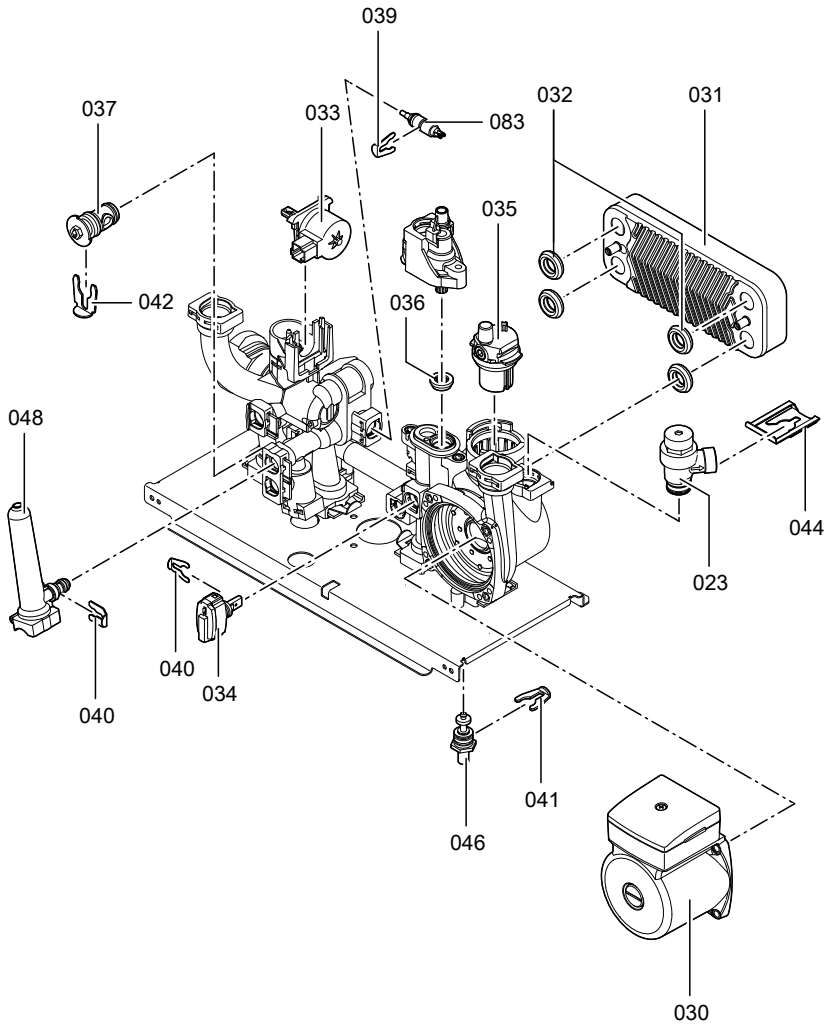

Parts lists (cont.)

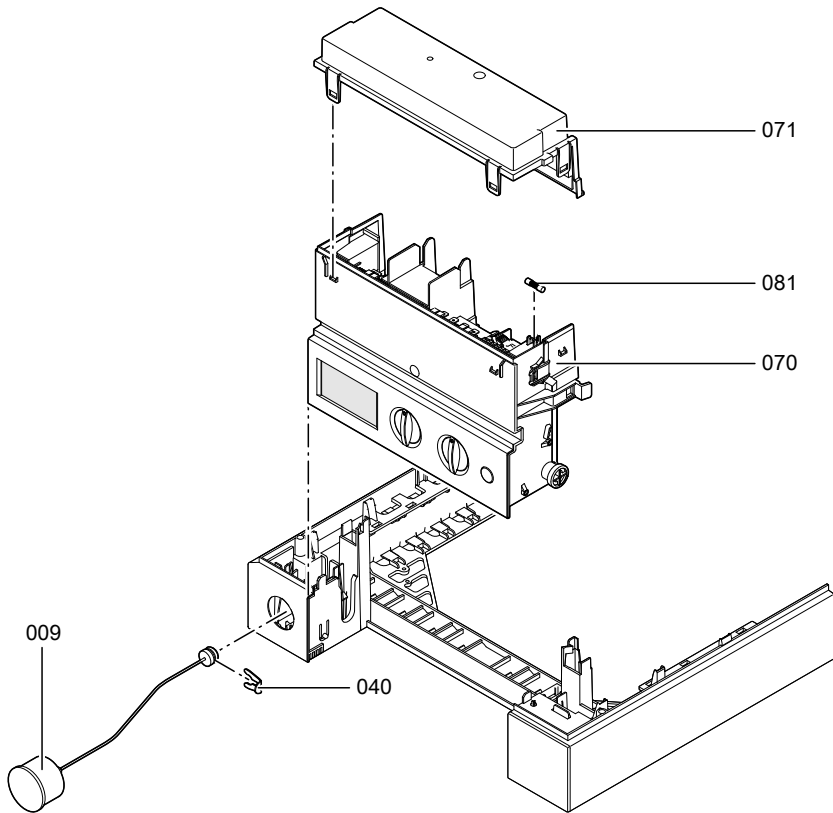

Specification

Rated voltage:	230 V~	Temperature limiter	
Rated frequency:	50 Hz	setting:	100 °C (fixed)
Rated current:	2.0 A~	Line fuse (mains):	max. 16 A
Safety class:	I		
Protection:	IP X4 to EN 60529		

Permissible ambient temperature

- during operation: 0 to +40 °C
- during storage and
- transport: -20 to +65 °C

Gas fired condensing boiler, class II_{2H3P}

Rated output range in heating mode				
T_v/T_R 50/30 °C	kW	9 to 26	11 to 30	11 to 35
T_v/T_R 80/60 °C	kW	8.2 to 23.7	10.0 to 27.3	10.0 to 31.9
Rated output range for DHW heating				
	kW	8.2 to 23.7	10.0 to 27.3	10.0 to 31.9
Rated thermal load range				
	kW	8.4 to 24.3	10.3 to 28.0	10.3 to 32.7
Connection values ¹				
relative to the max. load with				
Natural gas H	m ³ /h	2.6	3.0	3.5
LPG P	kg/h	1.9	2.2	2.6
Power consumption (max.)				
	W	107	111	154
Weight without front panel (installation)				
	kg	33	38	38
Product ID		C€-0085 BT 0029		

¹ The supply values are only for documentation purposes (e.g. in the gas contract application) or to estimate the supplementary volumetric settings. Because of factory settings, the gas pressure must not be altered from these settings. Reference: 15 °C, 1013 mbar.

Specification

Specification (cont.)

Gas fired condensing combi boiler, class II _{2H3P}

Rated output range in heating mode				
T_V/T_R 50/30 °C	kW	9 to 26	11 to 26	11 to 26
T_V/T_R 80/60 °C	kW	8.2 to 23.7	10.0 to 23.7	10.0 to 23.7
Rated output range for DHW heating	kW	8.2 to 26.0	10.0 to 30.0	10.0 to 35.0
Rated thermal load range	kW	8.4 to 27.1	10.3 to 31.3	10.3 to 36.5
Connection values ²				
relative to the max. load with				
Natural gas H	m ³ /h	2.9	3.3	3.9
LPG P	kg/h	2.1	2.4	2.9
Power consumption (max.)	W	111	144	167
Gas fired condensing combi boiler (DHW heating)				
Permiss. operating pressure	bar	10	10	10
Rated water volume at $\Delta T = 35$ K	l/min	10.6	12.3	14.3
Set flow rate (max.)	l/min	10.0	12.0	14.0
Weight without front panel (installation)	kg	34	39	39
Product ID	CE-0085 BT 0029			

² The supply values are only for documentation purposes (e.g. in the gas contract application) or to estimate the supplementary volumetric settings. Because of factory settings, the gas pressure must not be altered from these settings. Reference: 15 °C, 1013 mbar.

Declaration of conformity

Declaration of conformity for the Vitodens 100-W

We, Viessmann Werke GmbH&Co KG, D-35107 Allendorf, confirm as sole responsible body that the product **Vitodens 100-W** complies with the following standards:

DIN 4702-6	EN 55 014
EN 483	EN 60 335
EN 625	EN 61 000-3-2
EN 677	EN 61 000-3-3
EN 50 165	

In accordance with the following Directives, this product is designated **CE-0085**:

90/396/EEC	2004/108/EC
92/ 42/EEC	2006/95/EC

This product complies with the requirements of the Efficiency Directive (92/42/EEC) for **condensing boilers**.

Allendorf, 04.02.08

Viessmann Werke GmbH&Co KG



pp. Manfred Sommer

Keyword index

B

Boiler water temperature sensor	39
Burner gasket.....	25
Burner gauze assembly.....	25
Burner installation.....	29
Burner removal.....	24

C

Cleaning the combustion chamber....	26
Cleaning the heat exchanger.....	26
Commissioning.....	18
Condensate connection.....	12
Condensate drain.....	28
Connection diagram.....	53
Connections.....	9
Connections on the water side.....	9
Cylinder temperature sensor	40

D

Declaration of conformity.....	63
--------------------------------	----

E

Electrical connections.....	14
-----------------------------	----

F

Fault code.....	33
Fault messages.....	33
Filling function.....	18
Filling the system.....	18, 19
Flow limiter.....	45
Flue pipe.....	13
Frost protection.....	52
Function sequence.....	32
Fuse.....	47

G

Gas connection.....	11
Gas type conversion.....	20, 49
■ LPG.....	21
■ Natural gas.....	49

H

Heating curve.....	52
--------------------	----

I

Ignition.....	26
Ignition electrodes.....	26
Ionisation electrode.....	26

L

LPG.....	20
----------	----

O

Opening the control unit.....	13
Outlet temperature sensor.....	43, 44
Outside temperature sensor	37

P

Plate-type heat exchanger.....	47
--------------------------------	----

R

Reset.....	36
------------	----

S

Safety chain	41
Safety valve.....	10
Siphon.....	12, 28
Spare parts.....	55
Specifications	61
System pressure.....	19

T

Temperature limiter.....	41
Troubleshooting.....	37

V

Ventilation air pipe.....	13
Venting.....	20

W

Wall mounting.....	7
Weather-compensated mode.....	52



Viessmann Werke GmbH&Co KG
D-35107 Allendorf
Telephone: +49 6452 70-0
Fax: +49 6452 70-2780
www.viessmann.com

Viessmann Limited
Hortonwood 30, Telford
Shropshire, TF1 7YP, GB
Telephone: +44 1952 675000
Fax: +44 1952 675040
E-mail: info-uk@viessmann.com

5366 836 GB Subject to technical modifications.



Printed on environmentally friendly,
chlorine-free bleached paper