

Datasheet

For part no. and prices: see pricelist



VITODENS 050-W Type BPJD

Gas condensing combi boiler
With integral DHW heating
For natural gas and LPG

Product description



- (A) Inox-Radial heat exchanger made from stainless steel – for high operational reliability, a long service life and high heating output on a very small footprint
- (B) Modulating MatriX cylinder burner
- (C) Integral diaphragm expansion vessel
- (D) Variable speed combustion air fan for quiet and economical operation
- (E) Integral high efficiency circulation pump
- (F) Plate heat exchanger for DHW heating
- (G) Gas and water connections
- (H) Control unit with display

With the Vitodens 050-W, Viessmann now offers an attractively priced wall mounted gas condensing boiler with proven quality. An extensive range of accessories makes the Vitodens 050-W equally suitable for either new build or modernisation. It is offered with three output ratings (6.5 to 20 kW, 6.5 to 24 kW and 8.8 to 33 kW), as a combi boiler with an integral instantaneous water heater.

An electronic boiler control unit for room temperature-dependent mode and weather-compensated mode is already integrated into the Vitodens 050-W, along with a frost stat. The outside temperature sensor is available as an accessory.

The Vitodens 050-W features a low level of operating noise and its components are accessible from the front for service and maintenance.

With a height of only 707 mm, the Vitodens 050-W is one of the smallest wall mounted boilers in its class. Its compact dimensions recommend it as a replacement for outdated boilers in multi storey buildings – including up to six boilers on different floors connected to one vertical flue system.

The high quality stainless steel Inox-Radial heat exchanger efficiently converts the supplied energy into heat. Its efficiency is 97 % (H_s) [gross cv]. The MatriX cylinder burner therefore consumes relatively little natural gas, with lower CO₂ emissions and less impact on the environment as a result.

Recommended applications

Property development, either modernisation or new build (replacement of water heaters in apartment buildings)

Benefits at a glance

- Standard seasonal efficiency [to DIN]: Up to 97 % (H_s) [gross cv]
- Modulation range 1:4 (1:3 at 20 kW)
- Stainless steel MatriX cylinder burner and Inox-Radial heat exchanger
- Easy to operate control unit with display
- High DHW convenience thanks to DHW booster function
- Compact dimensions, ideal for replacement of old boilers

Delivered condition

Wall mounted gas condensing boiler with Inox-Radial heat exchanger, modulating MatriX cylinder burner for natural gas and LPG to DVGW Code of Practice G260 [Germany], hydraulics with multi connect system and circulation pump.
Fully plumbed and wired. Colour of the epoxy-coated casing: White.
With diaphragm expansion vessel
Plate heat exchanger for DHW heating
Outside temperature sensor

Tested quality

CE CE designation according to current EC Directives

Meets the requirements for the "Blue Angel" ecolabel to RAL UZ 61.

Specification

Gas boiler, types B and C					
Category II _{2H3P} , II _{2ELWLS3P} , I _{2E(S)} , I _{3P} , II _{2ESI3P}					
Type	BPJD				
Rated heating output range (details to EN 15502)					
T _F /T _R = 50/30 °C	kW	6.5 - 20.0	6.5 - 24.0	8.8 - 33.0	
T _F /T _R = 80/60 °C	kW	5.9 - 18.1	5.9 - 22.1	8.0 - 30.3	
Rated heating output range for DHW heating		kW	6.5 - 29.0	5.9 - 29.0	8.0 - 35.0
Rated heat input		kW	6.1 - 18.5	6.1 - 22.4	8.2 - 30.9
Product ID		CE-0063CS3199			
IP rating		IP X4D to EN 60529			
Efficiency					
– At rated heating output (100 % T _F /T _R = 80/60 °C)		97.6	97.6	97.5	
– At partial load (30 % T _F /T _R = 50/30 °C)		108.5	108.5	108.7	
Gas supply pressure					
Natural gas	mbar	20	20	20	
	kPa	2	2	2	
LPG	mbar	50	50	50	
	kPa	5	5	5	
Max. perm. gas supply pressure*¹					
Natural gas	mbar	25.0	25.0	25.0	
	kPa	2.5	2.5	2.5	
LPG	mbar	57.5	57.5	57.5	
	kPa	5.75	5.75	5.75	
Min. perm. gas supply pressure					
Natural gas	mbar	10.0	10.0	10.0	
	kPa	1.0	1.0	1.0	
LPG	mbar	10.0	10.0	10.0	
	kPa	1.0	1.0	1.0	
Sound power level (to EN 15036-1)					
– At rated heating output		dB(A)	45	45	48
– At partial load		dB(A)	39	39	38
Power consumption					
– In the delivered condition		W	55	56	90
– Max.		W	70	72	110
Weight		kg	35	35	37
Heat exchanger capacity		l	2.2	2.2	2.8
Nominal circulating water volume		l/h	941	941	1294
At T _F /T _R = 80/60 °C					
Diaphragm expansion vessel					
Capacity		l	8	8	8
Pre-charge pressure	bar	0.8	0.8	0.8	
	kPa	80	80	80	
Permiss. operating pressure		bar	3	3	3
		MPa	0.3	0.3	0.3
Dimensions					
Length	mm	350	350	350	
Width	mm	400	400	400	
Height	mm	707	707	707	
Gas connection		G	³ / ₄	³ / ₄	³ / ₄
Standby instantaneous water heater					
DHW and cold water connections		G	¹ / ₂	¹ / ₂	¹ / ₂
Permiss. operating pressure (DHW side)	bar	10	10	10	
	MPa	1	1	1	
Minimum pressure, cold water connection	bar	1.0	1.0	1.0	
	MPa	0.1	0.1	0.1	
Outlet temperature, adjustable		°C	30-60	30-60	30-60
Continuous DHW output		kW	29.0	29.0	35.0
Draw-off rate		l/min	3.0-12.0	3.0-12.0	3.0-14.3
For DHW heating from 10 to 45 °C					
Specific flow rate		l/min	13.8	13.8	16.7
At ΔT = 30 K (to EN 13203)					
Supply values					
Relative to the max. load with gas					
Natural gas E	m ³ /h	1.96	2.4	3.3	
LPG P	kg/h	1.41	1.8	2.4	

*¹ If the gas supply pressure is higher than the maximum permissible value, install a separate gas pressure governor upstream of the system.

Specification (cont.)

Gas boiler, types B and C Category II _{2H3P} , II _{2ELwLs3P} , I _{2E(S)} , I _{3P} , II _{2ESi3P}		BPJD		
Type				
Rated heating output range (details to EN 15502)				
T _F /T _R = 50/30 °C	kW	6.5 - 20.0	6.5 - 24.0	8.8 - 33.0
T _F /T _R = 80/60 °C	kW	5.9 - 18.1	5.9 - 22.1	8.0 - 30.3
Flue gas parameters^{*2}				
Flue gas category to G 635/G 636		G ₅₂ /G ₅₁	G ₅₂ /G ₅₁	G ₅₂ /G ₅₁
Temperature (at a return temperature of 30 °C)				
– At rated heating output	°C	47	45	45
– At partial load	°C	36	35	35
Temperature (at a return temperature of 60 °C)				
	°C	68	68	70
Mass flow rate				
Natural gas				
– At rated heating output (DHW heating)	kg/h	38.1	38.1	52.4
– At partial load	kg/h	14.6	14.6	17.6
LPG				
– At rated heating output (DHW heating)	kg/h	42.9	42.9	58.9
– At partial load	kg/h	15.9	15.9	19.4
Available draught				
	Pa	100	100	100
	mbar	1.0	1.0	1.0
Standard seasonal efficiency [to DIN]			Up to 97 (H _s) [gross cv]	
At T _F /T _R = 40/30 °C	%			
Max. amount of condensate				
To DWA-A 251	l/h	3.1	3.1	4.3
Condensate connection (hose nozzle)		20-24	20-24	20-24
Flue gas connection		Ø mm	60	60
Ventilation air connection		Ø mm	100	100
Energy efficiency class				
– Heating		A	A	A
– DHW heating, draw-off profile L		A	A	A
Energy efficiency index (EEI) of the installed circulation pump (details to EN 16297)		≤ 0.20	≤ 0.20	≤ 0.20

^{*2} Calculation values for sizing the flue system to EN 13384.

Flue gas temperatures as actual gross values at 20 °C combustion air temperature.

The flue gas temperature at a return temperature of 30 °C is significant for the sizing of the flue system.

The flue gas temperature at a return temperature of 60 °C is used to determine the application range of flue pipes with maximum permissible operating temperatures.

Specification (cont.)

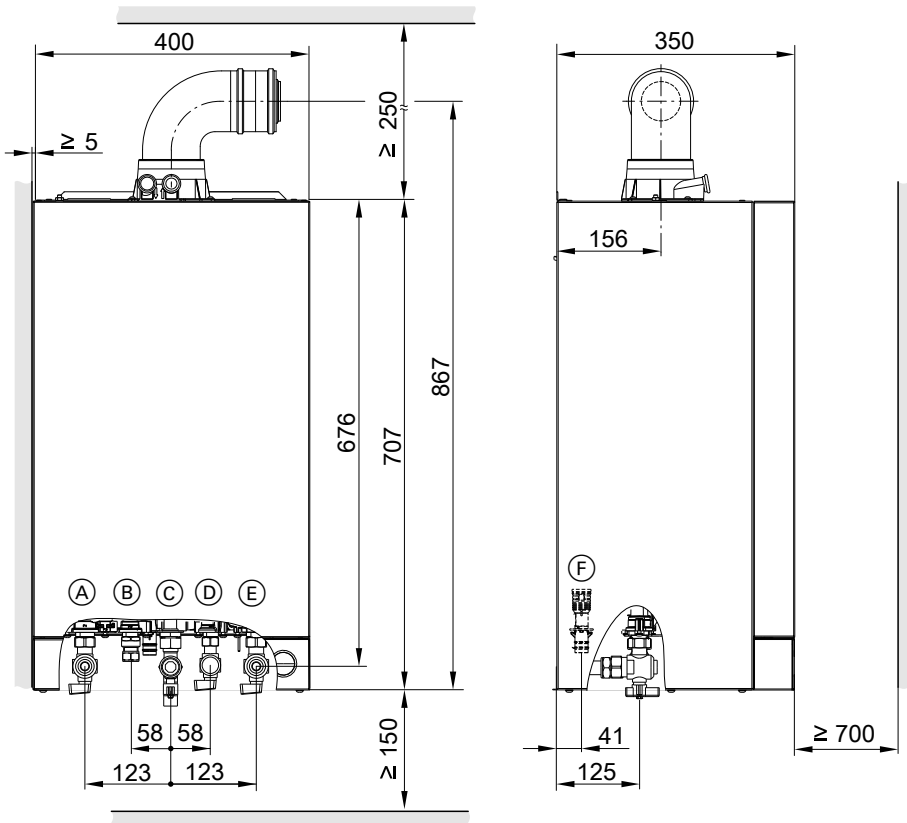

- | | |
|------------------------------------|---|
| (A) Heating flow G $\frac{3}{4}$ | (D) Cold water G $\frac{1}{2}$ |
| (B) DHW G $\frac{1}{2}$ | (E) Heating return G $\frac{3}{4}$ |
| (C) Gas connection G $\frac{3}{4}$ | (F) Condensate drain/safety valve drain: Plastic hose \varnothing 22 mm |

Note

Height dimensions in combination with a balanced flue bend \varnothing 60/100 mm. In combination with a balanced flue inspection bend \varnothing 60/100 mm, the total height is reduced by 10 mm.

Specification (cont.)

Residual head of integral circulation pump

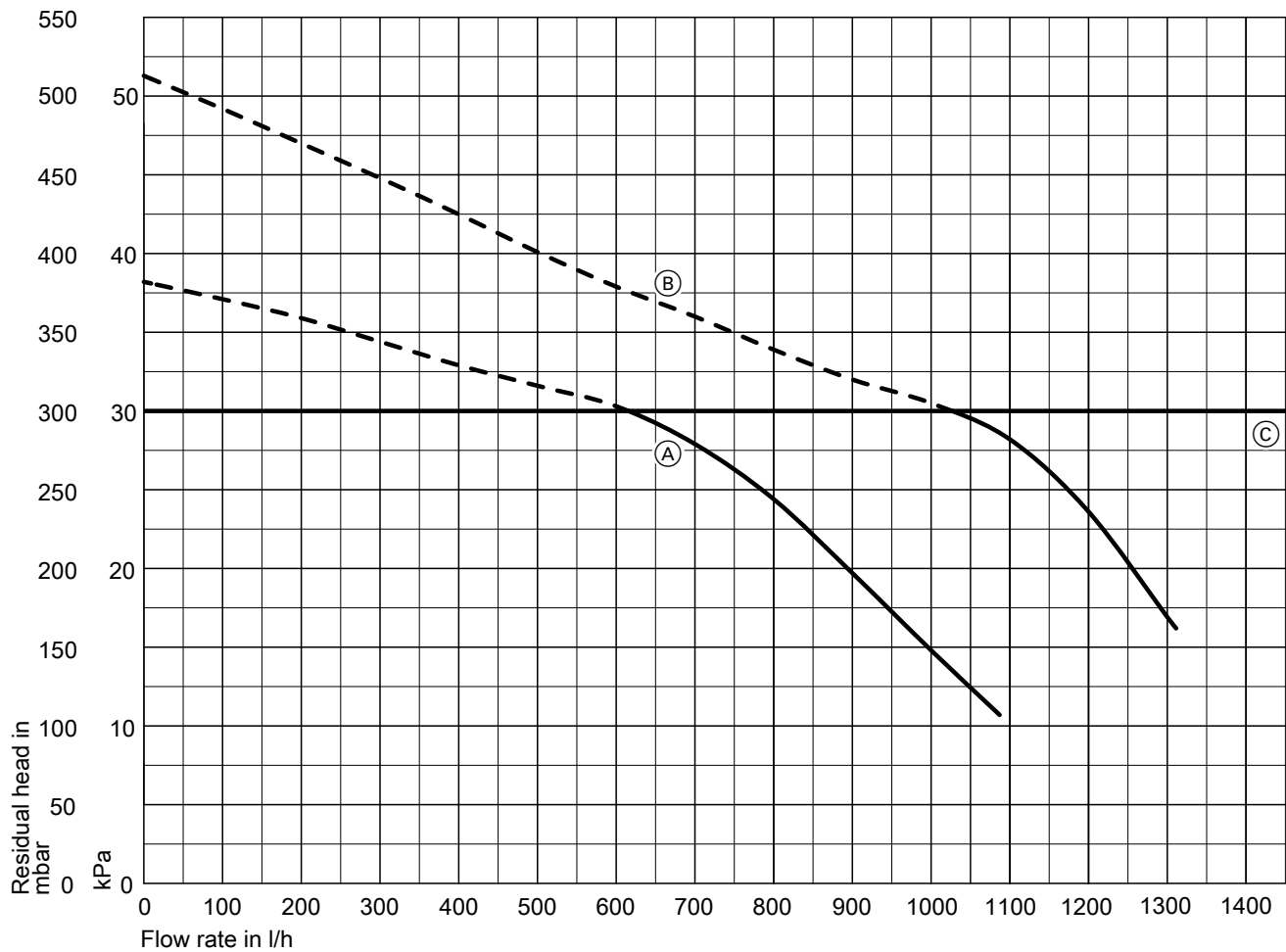

- Ⓐ 6.5 to 24 kW
- Ⓑ 8.8 to 33 kW
- Ⓒ Upper operational limit

Installation accessories

Mounting frame for surface mounting

Part no. ZK01500

Installed depth 50 mm

Comprising:

- Fixings

Installation accessories (cont.)

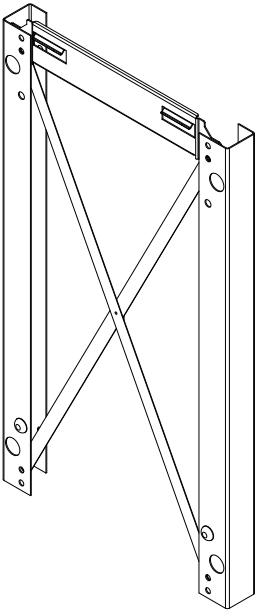

Valve/fitting cover

- For installation without mounting frame
Part no. 7835443
- For installation with mounting frame
Part no. ZK01501

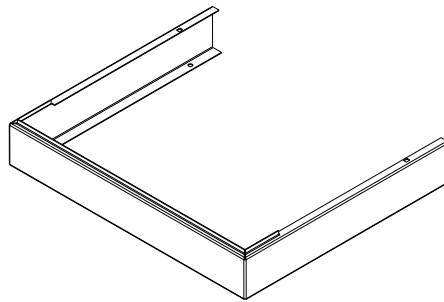

Neutralising system with wall mounting bracket

Part no. ZK03652
With neutralising granulate

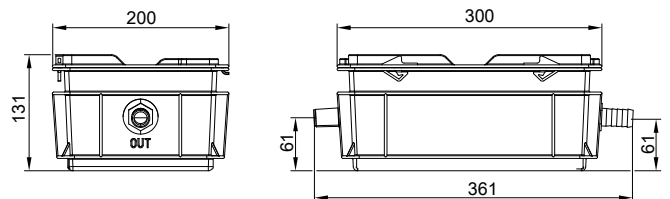

Neutralising granulate

Part no. ZK03654
2.5 kg

To match the neutralising system, part no. ZK03652

Design information

Siting

Siting conditions for open flue operation (appliance type B)
Type B₂₃ and B₃₃

5700484

Design information (cont.)

In rooms where **air contamination from halogenated hydrocarbons** or **organosilicon compounds (e.g. siloxanes)** may occur, such as hairdressing salons, printing shops, chemical cleaners, laboratories, etc., the Vitodens may only be operated as a room sealed system.

If in doubt, please consult us.

Never install the Vitodens in areas subject to very dusty conditions. The installation location must be kept free from frost and must be adequately ventilated.

Provide a condensate drain and a discharge pipe for the safety valve in the installation room.

The maximum ambient temperature of the system should not exceed 45 °C.

If these instructions are not observed, any consequential appliance damage directly related to any of these causes is excluded from our warranty.

Installation room

Permissible:

- Siting on the same floor
- Living space with interconnected room air supply
- Ancillary rooms with interconnected room air supply (larders, basements, utility rooms, etc.)
- Ancillary rooms with vents to the outside, up to 35 kW: Ventilation air/extract air 150 cm² or 2 x 75 cm² each at the top and bottom of the same wall
- Attic rooms, but only with adequate minimum chimney height to DIN 18160 – 4 m above inlet (negative pressure operation).

Not permissible:

- Stairwells and communal hallways. Exception: In detached and two-family houses of low height, top edge of floor in the top storey < 7 m above ground level.
- Bathrooms and toilets without outside windows with shaft ventilation
- Rooms where explosive or flammable materials are stored
- Rooms that are ventilated mechanically or via individual duct systems to DIN 18117-1

Observe all local fire regulations.

Connection on the flue gas side

For further details, see the technical guide on flue systems for the Vitodens.

The connection piece to the chimney should be as short as possible. Therefore position the Vitodens as close to the chimney as possible. No special protective measures or clearances towards combustible objects, e.g. furniture, packaging, etc., need to be taken/observed. The surface temperatures of the Vitodens and the flue system do not exceed 85 °C at any point.

Extractors

When installing appliances with extraction to the outside (cooker hoods, extractor fans, etc.), ensure that air extraction will not create negative pressure inside the installation room. A return flow of flue gases could result if the ventilation system and the Vitodens are operated simultaneously. In such cases, install an **interlock circuit**.

Siting conditions for room sealed operation (appliance type C)

Type C_{13x}, C_{33x}, C_{43x}, C_{53x}, C_{63x}, C_{83x} or C_{93x} to TRGI 2008

The Vitodens can be installed for **room sealed** operation **independent** of the size and ventilation of the installation room.

Suitable siting locations include:

- Recreational rooms and other living spaces
- Unventilated ancillary rooms
- Cabinets (open at the top)
- Recesses without compulsory clearance towards combustible materials
- Attic rooms (pitched attics and long panes) where the balanced flue pipe can be routed directly through the roof

Since the flue pipe connection for room sealed operation is surrounded by combustion air (coaxial pipe), no clearances towards combustible materials need to be maintained.

Ventilation air ducts with which oil or solid fuel boilers were previously used must not contain any sulphur or soot deposits on the inner surfaces of the chimney. Sulphur and soot deposits cause operating faults. If thorough cleaning is not possible, a balanced flue pipe must be laid through the shaft. Alternatively, the flue gas/ventilation air pipes can be routed separately. Viessmann accepts no liability for damages resulting from failure to observe these instructions. For further details, see the technical guide on flue systems for the Vitodens.

The installation room must be free from the risk of frost.

Provide a condensate drain and a discharge pipe for the safety valve in the installation room.

Electrical interlocks for extractors (extractor hoods, etc.) are not required with room sealed operation.

Using third party flue systems

Any approved flue system can be used for type C₆₃/C_{63x}. These flue systems are not tested together with the boilers and do not have system certification in accordance with the Gas Appliances Regulation (EU) 2016/426.

With type C₆₃/C_{63x}, Viessmann heat generators may only be operated with the types intended for the respective products (e.g. C_{13x}, C_{33x}, C_{14(3)x}, C_{53x}, C_{83x}, C_{93x}). If used, the Viessmann design specifications in the technical guides to flue systems must be adhered to and appliance-specific details (e.g. max. draughts, flue gas temperatures, mass flow rates, boiler flue connection tolerances) must be observed.

At the terminal of the flue system, ensure that a maximum reverse flow of flue gas of 10 % is not exceeded, even when it is windy. Wind protection devices for the supply of combustion air and the discharge of flue gas must not be installed on opposite walls of the building. Measures inside the equipment ensure that the flue gas temperature of 110 °C will never be exceeded. An approved flue made from plastic (PPS) with a max. flue gas temperature of 120 °C (type B) can be used.

If aluminium flue pipes are used, a condensate trap must additionally be installed above the boiler flue connection to prevent impairments to the heat generator caused by aluminium residues in the condensate. Size the condensate trap in such a way that the condensate returned from the flue system completely bypasses the heat generator.

Installation in a garage

Tests carried out by the Gaswärme-Institut e.V., Essen, have confirmed that the Vitodens is suitable for installation in garages.

When installing this boiler in a garage, maintain a clearance between the floor and the burner of at least 500 mm. Install a frame or deflector (provided on site) to protect the boiler against mechanical damage.

Operation of the Vitodens in wet rooms

Installation of the Vitodens is permitted in wet rooms (e.g. bath or shower rooms).

When installing the Vitodens in wet rooms, observe the safety zones and minimum wall clearances according to VDE 0100 [or local regulations] (see also "Electrical safety zone").

Design information (cont.)

- Room sealed operation:
 - Protection rating IP X4 D, splashproof
 - The appliances may be installed in safety zone 1 if hosed water (e.g. from massage showers) is prevented.
- Open flue operation:
 - The appliances must not be installed in safety zone 1 or safety zone 2.

Electrical safety zone

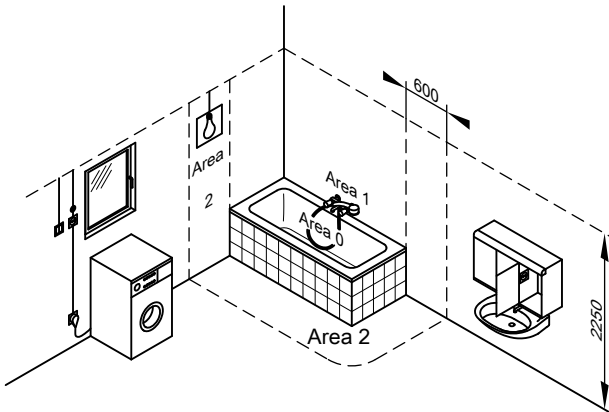

Electrical equipment in rooms containing a bathtub or a shower must be installed in such a way that users cannot be exposed to dangerous shock currents.

VDE 0100 specifies that cables supplying permanently installed consumers in zones 1 and 2 should only be run vertically and routed into the equipment from the back.

Electrical connection

The power supply must comply with the requirements of your local power supply utility and current VDE [or local] regulations. Protect the power cable with a fuse with a max. rating of 10 A. We recommend installing an AC/DC-sensitive RCD (RCD class B) for DC (fault) currents that can occur with energy efficient equipment.

Make the power supply (230 V~, 50 Hz) via a permanent connection. In the delivered condition, the power cable is connected.

The accessories are connected at the terminals on the underside of the appliance.

Recommended cables

2-core min. 0.75 mm² for:

- Outside temperature sensor
- Vitotrol 100, type RT LV

- Vitotrol 100, type UTA LV
- Vitotrol 100, type UTDB

Gas connection

Gas installations must only be carried out by a registered gas fitter authorised by the relevant gas supply utility. Connect and size the mains gas according to TRGI 2008 or TRF 1996 [or local regulations].

Max. test pressure 150 mbar (15 kPa).

We recommend installing a gas filter to DIN 3386 in the gas line.

Minimum clearances

Maintain a clearance of 700 mm in front of the Vitodens for maintenance purposes.

No maintenance clearances are required to the left or right of the Vitodens.

Connections on the water side

Connections on the DHW side

The instantaneous water heater provides direct DHW heating. If used in conjunction with galvanised pipes, note that the instantaneous water heater is designed as a stainless steel plate heat exchanger with copper solder joints (observe the flow rule). In existing installations (modernisation projects), the risk of electrolytic corrosion is low, since a protective layer will have formed on the inside of the pipes.

With water hardness of 20 °dH and higher, we recommend the use of a water treatment system in the cold water line when heating DHW.

5700484

Design information (cont.)

Note on drinking water quality

During DHW heating, settling of lime on the surfaces of the plate heat exchanger cannot be completely prevented. The tendency towards limescale build-up depends on various conditions, predominantly on the substances contained in the water, the amount of water that is heated (DHW consumption) and the DHW temperature. Although scale deposits inside the plate heat exchanger are generally minor enough not to cause any reduction in DHW output, such impairment cannot be excluded with increased water hardness. From a water hardness of 20 °dH (3.5 mol/m³) and higher, we therefore recommend the use of DHW cylinders with internal indirect coils or a water treatment system in the cold water supply when heating DHW.

Cold water installation

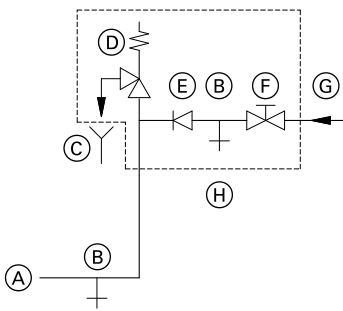

- (A) Cold water connection of boiler
- (B) Drain
- (C) Visible discharge pipe outlet point
- (D) Safety valve
- (E) Non-return valve
- (F) Shut-off valve
- (G) Cold water
- (H) Safety assembly

A safety valve to DIN 1988 is only required if the mains water supply pressure exceeds 10 bar (1 MPa) and no DHW pressure reducing valve is installed (to DIN 4753).

Install a safety valve if the cold water supply is equipped with a non-return valve. In addition remove the toggle from the cold water shut-off valve.

Non-return valves are commonly found in pressure reducers and combined shut-off and non-return valves.

DHW circulation for gas condensing combi boilers

Due to the low water content of plate heat exchangers, the connection of DHW circulation pipes is **not recommended** for gas condensing combi boilers.

Condensate connection

Route the condensate pipe with a constant fall.

Route the condensate from the flue system together with the boiler condensate directly or via a neutralising system (if installed – accessories) to the public waste water system.

Note

A pipe vent **must** be installed between the trap and the neutralising system.

Please note that regional water supply utilities frequently specify an average water hardness. Higher levels of water hardness may therefore occur from time to time. This may make the use of a water treatment facility advisable even from 17 °dH (> 3.0 mol/m³) upwards.

Shock arrestor

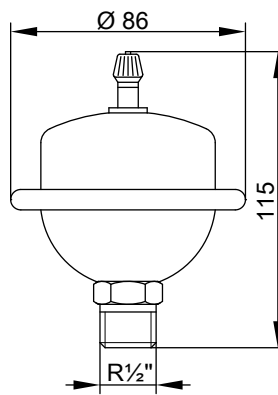

If the pipework to which the Vitodens is connected also supplies draw-off points at which water hammers may occur (e.g. pressure washers, washing machines or dishwashers): Install shock arrestors near the source of the water hammer (recommended).

Flexofit S made by Flamco-Flexcon

or

Reflex made by Winkelmann + Pannhoff GmbH

(available from your local dealer).

Even the low heat losses of thermally insulated DHW circulation lines (to EnEV) lead to a higher cycling frequency for the gas condensing combi boiler (reheating).

Design information (cont.)

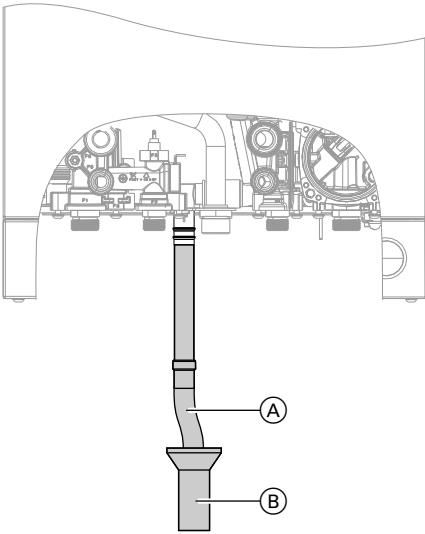

- (A) Drain hose (Vitodens standard delivery)
- (B) Drain outlet kit (accessories)

Condensate drain pipe and neutralisation

During heating operation, condensate with pH values between 4 and 5 is formed in the condensing boiler and in the flue. The condensate should be drained in accordance with appropriate regulations.

Code of Practice DWA-A 251 on "Condensate from condensing boilers", which is generally based on the local waste water regulations [in Germany], determines conditions for draining condensate from condensing boilers into the public sewer system.

The composition of condensate drained from Vitodens condensing boilers meets the requirements specified in Code of Practice DWA-A 251.

The condensate drain pipe to the sewer connection must be freely accessible for inspection.

It must be installed with a continuous fall and must contain a stench trap. Also provide a suitable facility for sampling.

Condensate drain pipes must only be made from corrosion-resistant materials (e.g. reinforced hoses).

Never use any zinc-plated materials or those containing copper for pipes, connection pieces, etc.

A trap is installed in the condensate drain to prevent flue gases escaping.

Local water regulations and/or specific technical circumstances may prescribe designs that vary from those described in the above Codes of Practice.

Contact your local authority responsible for waste water management in good time prior to installation, to find out about local regulations.

Condensate from gas combustion equipment up to 200 kW combustion output

Up to a rated heating output of 200 kW, the condensate from a gas condensing boiler can generally be introduced into the public waste water system without prior neutralisation.

Domestic drainage systems must be made from materials that are resistant to acidic condensate.

According to the Code of Practice DWA-A 251, these materials include:

- Vitrified clay pipes
- Hard PVC pipes

- PVC pipes
- PE HD pipes
- PE pipes
- ABS/ASA pipes
- Stainless steel pipes
- Borosilicate pipes

Neutralising system

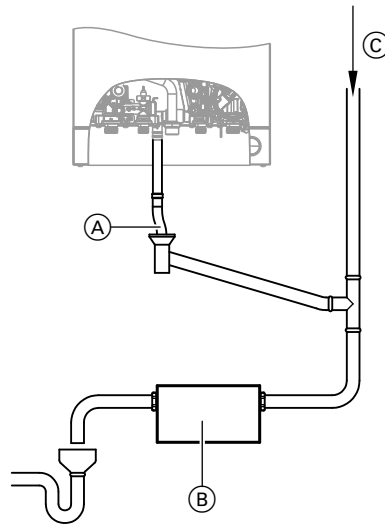

- (A) Condensate drain
- (B) Neutralising system
- (C) Ventilation via the roof

The Vitodens can (if required) be supplied with a separate neutralising system (accessories). Any condensate is piped to and processed in the neutralising system.

The condensate drain pipe to the sewer connection must be accessible for inspection. Install it with a fall and a stench trap on the sewer side, and provide a suitable facility for extracting samples.

Install a condensate lifting pump if the Vitodens has been installed below the waste water anti-flooding level.

Since the consumption of neutralising granulate depends on the operating mode of the system, carry out regular checks during the first year of operation to determine the required top-up volume. One fill can last longer than one year.

Neutralising system

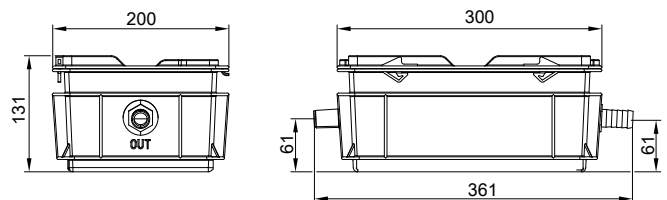

Hydraulic connection

General

System design

Viessmann condensing boilers can generally be installed in any fully pumped hot water heating system (sealed unvented system).

The circulation pump is an integral part of the appliance.

Minimum system pressure 1.0 bar (0.1 MPa).

The boiler water temperature is limited to 80 °C.

To minimise distribution losses, we recommend sizing the heat distribution system to a max. flow temperature of 70 °C.

Due to the immediate capturing of the room-influencing factors, we recommend using the Vitodens in conjunction with the Vitotrol 100 for apartments with less than 80 m² living space or for low energy houses with a low heat demand.

Chemical anti-corrosion agents

According to VDI guideline 2035, the design of heating systems must ensure they are sealed against corrosion. Additives in the heating water (additives, chemicals) as corrosion protection measures are normally not necessary.

Exception: In systems without system separation, for example, additives can be considered.

Heating circuits

For heating systems with plastic pipes, we recommend the use of impermeable pipes to prevent the diffusion of oxygen through the pipe walls.

Install a dirt separator in underfloor heating systems.

Install a temperature limiter in the flow of the underfloor heating circuit to restrict the maximum temperature. Observe DIN 18560-2 [or local regulations].

Plastic pipework for radiators

We also recommend the use of a temperature limiter to restrict the maximum temperature for plastic pipework in heating circuits with radiators.

Attic heating centre

The installation of a low water indicator, compulsory according to the DVGW [Germany], is not required when installing boilers in an attic heating centre.

The boilers are protected against water shortage in accordance with EN 12828.

Safety valve

A safety valve in accordance with TRD 721 is integrated in the Vitodens (opening pressure 3 bar (0.3 MPa)).

Route the discharge pipe in accordance with EN 12828 into a drain outlet (drain outlet kit available as an accessory). The drain outlet incorporates a siphon as a stench trap.

Low water indicator

According to EN 12828, a low water indicator can be omitted for boilers up to 300 kW, as long as heating can be reliably prevented when there is a water shortage.

Viessmann condensing boilers are equipped with a low water indicator (boil-dry protection). Tests have verified that the burner will be automatically switched off in the event of water shortage due to a leak in the heating system and simultaneous burner operation, before the boiler or the flue system reaches unacceptably high temperatures.

Water quality/Frost protection

Unsuitable fill and top-up water increases the level of deposits and corrosion and may lead to boiler damage.

Observe VDI guideline 2035 regarding the quality and volume of heating water, incl. fill and top-up water.

CH: Observe SWKI guideline BT 102-01.

- Flush the heating system thoroughly before filling.
- Only fill with water of potable quality.
- VDI guideline 2035 recommends water softening treatment to prevent harmful scaling in the heating water. Additives to stabilise hardness do not remove the scale forming chemicals from the heating water. Fill and top-up water with a water hardness in excess of the following values must be softened, e.g. with the small softening system for heating water (see the Viessmann Vitoset pricelist):

Total permissible hardness of the fill and top-up water

Total heating output kW	Specific system volume		
	< 20 l/kW	≥ 20 l/kW to < 50 l/kW	≥ 50 l/kW
≤ 50	≤ 3.0 mol/m ³ (16.8 °dH)	≤ 2.0 mol/m ³ (11.2 °dH)	< 0.02 mol/m ³ (0.11 °dH)
> 50 to ≤ 200	≤ 2.0 mol/m ³ (11.2 °dH)	≤ 1.5 mol/m ³ (8.4 °dH)	< 0.02 mol/m ³ (0.11 °dH)

- For systems with a specific system volume in excess of 20 l/kW heating output, use the output of the smallest boiler in multi boiler systems.
- Special antifreeze (category 1 to 3) suitable for heating systems can be added to the fill water. The use of glycols without sufficient inhibition and buffering is not permitted. The suitability of the antifreeze must be confirmed by the manufacturer. If antifreeze is added, more monitoring and maintenance is necessary. Observe the manufacturer's instructions. Viessmann accepts no liability for damage and malfunctions caused by unsuitable or incorrectly dosed antifreeze, or incorrect maintenance.
- EN 1717 and DIN 1988-100 must be observed if the heating water is used simultaneously as a heat transfer medium for DHW heating.
- When disposing of heating water that contains additives, check whether it may be discharged into the public drain network once it has been treated again.

When designing the system, observe the following:

- Install shut-off valves in each section. This prevents the need for draining all the heating water in the case of repairs or system expansion.
- In systems > 50 kW, install a water meter to record the volume of fill and top-up water. Record the amount of water filled into the system and the water hardness.

Operating information:

- Commission the system step by step, starting with the lowest boiler output and a high heating water flow rate. This prevents localised concentration of limescale deposits on the heating surfaces.
- In multi boiler systems, start all boilers simultaneously to prevent the total amount of limescale deposits settling in the heat exchanger of just one boiler.
- During expansion or repair work, only drain the necessary pipe-work sections.
- Where water treatment is required, treat even the first fill of the heating system prior to commissioning. This also applies to any subsequent filling, e.g. when adding top-up water or after a repair, or for any system expansion.
- Check, clean and activate filters, dirt traps and other blow down or separating facilities in the heating water circuit more frequently after commissioning and in new installations. Later on this can be carried out subject to the requirements of the water treatment applied (e.g. water softening).

Installation examples

Never install the Vitodens 050-W in dual mode systems with solid fuel boilers.

Design information (cont.)

Expansion vessels

In accordance with EN 12828, water heating systems must be equipped with a pressure expansion vessel.

Determine the size of the expansion vessel to be installed in accordance with EN 12828.

If the integral expansion vessel is insufficient, install a suitably sized expansion vessel on site.

Note

With regard to the hydraulic connection of the diaphragm expansion vessel, there must always be a connection between the diaphragm expansion vessel and the heat generator. For example, when the thermostat valves are closed and if the 3-way diverter valve is set to DHW heating.

Intended use

The appliance is intended solely for installation and operation in sealed unvented heating systems that comply with EN 12828, with due attention paid to the associated installation, service and operating instructions. It is only designed for heating up heating water that is of potable water quality.

Intended use presupposes that a fixed installation in conjunction with permissible, system-specific components has been carried out.

Commercial or industrial usage for a purpose other than heating the building or DHW shall be deemed inappropriate.

Any usage beyond this must be approved by the manufacturer in each individual case.

Incorrect usage or operation of the appliance (e.g. the appliance being opened by the system user) is prohibited and will result in an exclusion of liability. Incorrect usage also occurs if the components in the heating system are modified from their intended use (e.g. if the flue gas and ventilation air paths are sealed).

Control unit

Control unit for constant temperature or weather-compensated operation

Design and functions

Design

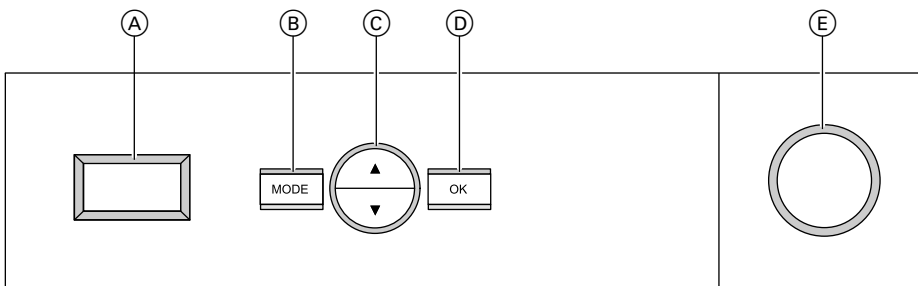

- (A) Display
- (B) Button for selecting/exiting a function
- (C) Buttons for changing/selecting a value

- (D) Button for accepting a value/confirming a selection
- (E) Pressure gauge

Programming unit:

- Adjustment of:
 - DHW temperature
 - Boiler water temperature or room temperature
 - Parameters
 - Service functions
 - Reset function
- Display of:
 - Boiler water temperature
 - DHW temperature
 - Operating states
 - Diagnostic data
 - Fault messages

Functions

- In conjunction with room temperature controller:
 - Room temperature-dependent control of boiler water temperature and/or flow temperature
- In conjunction with outside temperature sensor:
 - Weather-compensated control of boiler water temperature and/or flow temperature
- Control of a heating circuit without mixer
- Electronic maximum temperature limiter (permanently set)
- Demand-dependent heating circuit pump and burner shutdown control
- Pump anti-seizing protection
- Frost protection monitoring of the boiler
- Integral diagnostic system

Control characteristics

PI characteristics with modulating output

Control unit (cont.)

Time switch

A separate time switch (accessories) is available for installation in the control unit support

Setting the operating programs

Boiler frost protection monitoring (see frost protection function) is active in all operating programs.

The following operating programs can be selected by changing the set value:

- Heating and DHW
- DHW only

Frost protection function

Only in conjunction with an outside temperature sensor (accessories):

- The frost protection function will be started when the outside temperature falls below approx. +5 °C. In the frost protection function, the heating circuit pump is switched on and the boiler water is maintained at a lower temperature of approx. 20 °C.

Summer mode

The burner will only start when DHW is drawn.

Boiler water temperature sensor

The boiler water temperature sensor is connected to the control unit and built into the boiler.

Specification

Sensor type	Viessmann NTC 10 kΩ at 25 °C
Permissible ambient temperature	
– Operation	0 to +130 °C
– Storage and transport	–20 to +70 °C

Control unit specification

Rated voltage	230 V~
Rated frequency	50 Hz
Rated current	2 A
Protection class	I
Permissible ambient temperature	
– During operation	–5 to +40 °C
	Installation in living spaces or boiler rooms (standard ambient conditions)
– During storage and transport	–35 to +65 °C
Electronic temperature cut-out setting	100 °C (cannot be altered)
DHW temperature setting range	30 to 60 °C

Control unit accessories

Vitotrol 100 RT LV

Part no. ZK01502

Room thermostat with switching output (2-point output)
Install the Vitotrol 100 in the main living room on an internal wall opposite radiators, but not inside shelf units, recesses, immediately by a door or heat source (e.g. direct insolation, fireplace, TV set, etc.).

Control unit connection:

- 2-core cable for extra low voltage (ELV)

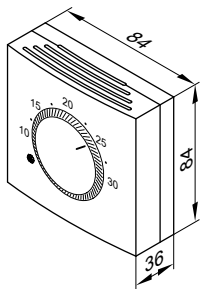

Specification

Rated voltage	24 V–
Rated breaking capacity of the contact	Max. 200 mA
IP rating	IP 30 to EN 60529
	Ensure through design/installation
Permissible ambient temperature	
– During operation	0 to +50 °C
– During storage and transport	–20 to +60 °C
Set value setting range for standard mode and reduced mode	10 to 30 °C

Vitotrol 100, type UTA-LV

Part no. Z013179

Room thermostat

- With switching output (2-point output)
- With analogue time switch
- With adjustable individual day program
- Standard switching times are factory-set (individually programmable)
- Shortest switching interval 15 minutes

Install the Vitotrol 100 in the main living room on an internal wall opposite radiators, but not inside shelf units, recesses, immediately by a door or heat source (e.g. direct insolation, fireplace, TV set, etc.).

Control unit connection:

- 2-core cable for extra low voltage (ELV)
- Rated voltage 24 V–

Control unit accessories (cont.)

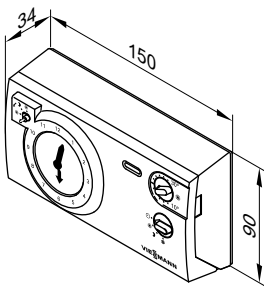

IP rating	IP 20 to EN 60529 Ensure through design/installation
Permissible ambient temperature	
– During operation	0 to +40 °C
– During storage and transport	–20 to +60 °C
Set value setting range for standard mode and reduced mode	10 to 30 °C
Set room temperature in standby mode	6 °C

Specification

Rated voltage	3 V– 2 LR6/AA batteries
Rated breaking capacity of the contact	Max. 200 mA

Vitotrol 100, type UTA-RF

Part no. Z013180

Room thermostat with integral wireless transmitter and separate wireless receiver

- With switching output (2-point output)
- With analogue time switch
- With adjustable individual day program

Installation in the main living room on an internal wall opposite radiators. Do not install inside shelving units, in recesses, or immediately by a door or heat source (e.g. direct sunlight, fireplace or TV set).

Operation independent of mains power supply

Wireless receiver for installation in the control unit support

Specification

Rated voltage	3 V– 2 LR6/AA batteries
IP rating	IP 20 to EN 60529; ensure through design/installation
Permissible ambient temperature	
– During operation	0 to +40 °C
– During storage and transport	–20 to +60 °C
Set value setting range for standard mode and reduced mode	10 to 30 °C
Set room temperature in standby mode	6 °C

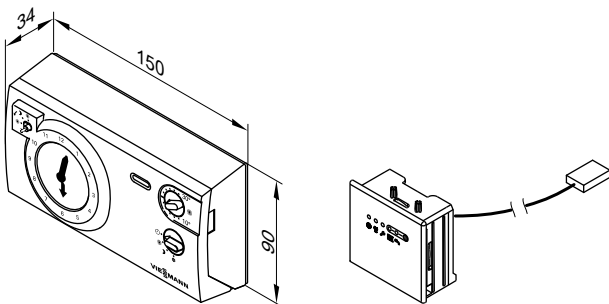

Vitotrol 100, type UTDB

Part no. Z007691

Room temperature controller

- With switching output (2-point output)
- With digital time switch
- With individual day and seven-day program
- With menu-guided operation:
 - 3 preselected time programs, individually adjustable
 - Constant manual mode with adjustable set room temperature
 - Frost protection mode
 - Holiday program
- With buttons for party and economy mode

Installation in the main living room on an internal wall opposite radiators. Do not install inside shelving units, in recesses, or immediately by a door or heat source (e.g. direct sunlight, fireplace or TV set).

Operation independent of mains power supply

Control unit connection:

2-core cable for extra low voltage (ELV)

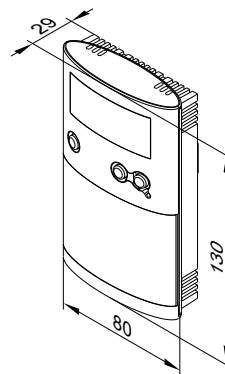

Control unit accessories (cont.)

Specification

Rated voltage	3 V– 2 LR6/AA batteries
Rated breaking capacity of the floating contact	
– Max.	6(1) A, 230 V~
– Min.	1 mA, 5 V–
IP rating	IP 20 to EN 60529; ensure through design/installation
Function type	RS type 1B to EN 60730-1

Permissible ambient temperature	
– Operation	0 to +40 °C
– Storage and transport	–25 to +65 °C
Setting ranges	
– Comfort temperature	10 to 40 °C
– Setback temperature	10 to 40 °C
– Frost protection temperature	5 °C
Power reserve during battery change	3 min

Vitotrol 100, type UTDB-RF2

Part no. Z013181

Room temperature controller with integral wireless transmitter and wireless receiver for installation in the control unit support

- With digital time switch
- With individual day and seven-day program
- Operation with user prompts:
 - 3 preselected time programs, individually adjustable
 - Constant manual mode with adjustable set room temperature
 - Frost protection mode
 - Holiday program
- With selector keys for party and economy mode

Installation in the main living room on an internal wall opposite radiators. Never install inside shelving units, in recesses, or immediately by a door or heat source (e.g. direct sunlight, fireplace, TV set, etc.). Operation independent of mains power supply
Wireless receiver with relay state indication.

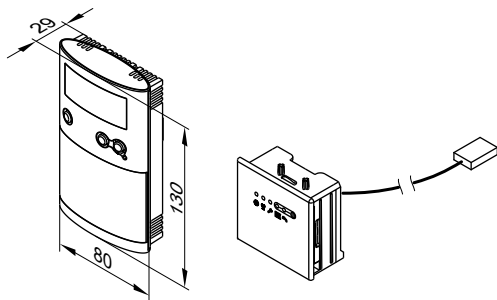

Specification, room temperature controller

Rated voltage	3 V– 2 LR6/AA batteries
Transmission frequency	868 MHz
Transmission	< 10 mW
Range	Approx. 25 to 30 m inside buildings, subject to construction
IP rating	IP 20 to EN 60529; ensure through design/installation
Function type	RS type 1B to EN 60730-1
Permissible ambient temperature	
– Operation	0 to +40 °C
– Storage and transport	–25 to +65 °C
Setting range	
– Comfort temperature	10 to 40 °C
– Setback temperature	10 to 40 °C
– Frost protection temperature	5 °C
Power reserve during battery change	3 min

Wireless receiver

- For installation in the control unit support
- With power cable and connector for connection to the control unit

Outside temperature sensor

Part no. ZK01505

Installation location:

- North or north-west facing wall of the building
- 2 to 2.5 m above the ground; for multi storey buildings in the upper half of the second floor

Connection:

- 2-core lead, length up to 35 m with a cross-section of 1.5 mm² (copper)
- Never route this lead immediately next to 230/400 V cables

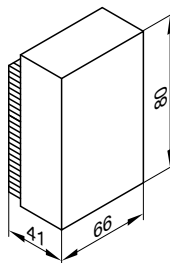

Specification

IP rating	IP 43 to EN 60529; ensure through design/installation
Sensor type	Viessmann NTC 10 kΩ at 25 °C
Permissible ambient temperature during operation, storage and transport	–40 to +70 °C

Control unit accessories (cont.)

Analogue time switch

Part no. ZK01506

- Single channel time switch with individual day program
- For installation in the control unit support
- With connecting cable and plug for connection to the control unit

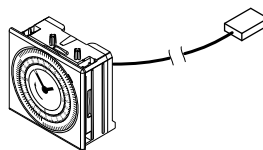

Digital time switch

Part no. ZK01507

- 2-channel time switch with seven-day program
- For installation in the control unit support
- With connecting cable and plug for connection to the control unit

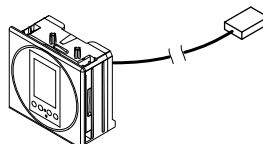

Electrical junction box 230 V

Part no. ZK02156

Relays the heat demand from the room temperature controller (clock thermostat) to the OpenTherm connection of the control unit.

- For installation in the control unit
- With connecting cable and plug for connection to the control unit
- With connecting cable for connection to the room temperature controller

Subject to technical modifications.

Viessmann Werke GmbH & Co. KG
D-35107 Allendorf
Telephone: +49 6452 70-0
Fax: +49 6452 70-2780
www.viessmann.com

Viessmann Limited
Hortonwood 30, Telford
Shropshire, TF1 7YP, GB
Telephone: +44 1952 675000
Fax: +44 1952 675040
E-mail: info-uk@viessmann.com

5700484