

Installation and service instructions

for contractors

VIESSMANN

Vitodens 222-F

Type B2TA, 3.2 to 35 kW

Gas condensing storage combi boiler

ⒸGB: Gas council no.

41-819-15; 41-819-16; 41-819-17

Natural gas and LPG version

For applicability, see the last page



VITODENS 222-F



Safety instructions



Please follow these safety instructions closely to prevent accidents and material losses.

Safety instructions explained



Danger

This symbol warns against the risk of injury.



Please note

This symbol warns against the risk of material losses and environmental pollution.

Note

Details identified by the word "Note" contain additional information.

Target group

These instructions are exclusively intended for qualified contractors.

- Work on gas installations must only be carried out by a registered gas fitter.
- Work on electrical equipment must only be carried out by a qualified electrician.
- The system must be commissioned by the system installer or a qualified person authorised by the installer.

Regulations

Observe the following when working on this system:

- Statutory regulations regarding the prevention of accidents
- Statutory regulations regarding environmental protection

- Codes of practice of the relevant trade associations
- All current safety regulations as defined by DIN, EN, DVGW, TRGI, TRF, VDE and all locally applicable standards
 - Ⓐ ÖNORM, EN, ÖVGW-TR Gas, ÖVGW-TRF and ÖVE
 - ⒸH SEV, SUVA, SVGW, SVTI, SWKI, VKF and EKAS guideline 1942: LPG, part 2

If you smell gas



Danger

Escaping gas can lead to explosions which may result in serious injury.

- Do not smoke. Prevent naked flames and sparks. Do not switch lights or electrical appliances on or off.
- Close the gas shut-off valve.
- Open windows and doors.
- Evacuate any people from the danger zone.
- Notify your gas or electricity supply utility from outside the building.
- Shut off the electricity supply to the building from a safe place (outside the building).

Safety instructions (cont.)

If you smell flue gas



Danger

Flue gas can lead to life-threatening poisoning.

- Shut down the heating system.
- Ventilate the installation site.
- Close all doors in the living space.

Flue systems and combustion air

Ensure that flue systems are clear and cannot be sealed, for instance due to accumulation of condensate or other causes. Ensure a sufficient supply of combustion air.

Instruct system users that subsequent modifications to the building characteristics are not permissible (e.g. cable/pipe-work routing, cladding or partitions).



Danger

Life-threatening poisoning caused by carbon monoxide in the flue gas occurs as a result of leaking or blocked flue systems or an insufficient supply of combustion air.

Ensure the flue system is in proper working order. It must not be possible to close apertures for interconnected combustion air supply.

Extractors

Operating appliances that extract air to the outside (cooker hoods, extractors, air conditioning units, etc.) can create negative pressure. If the boiler is operated at the same time, this can lead to reverse flow of the flue gas.



Danger

The simultaneous operation of the boiler and appliances that extract air to the outside can result in life threatening poisoning due to reverse flow of the flue gas.

Fit an interlock circuit or take suitable steps to ensure a sufficient supply of combustion air.

Working on the system

- Where gas is used as the fuel, close the main gas shut-off valve and safeguard it against unintentional reopening.
- Isolate the system from the power supply (e.g. by removing the separate fuse or by means of a mains isolator) and check that it is no longer 'live'.
- Safeguard the system against reconnection.



Please note

Electronic assemblies can be damaged by electrostatic discharge.

Prior to commencing any work, touch earthed objects, such as heating or water pipes to discharge static loads.

Repair work



Please note

Repairing components that fulfil a safety function can compromise the safe operation of your system.

Defective components must be replaced with genuine Viessmann spare parts.

Safety instructions (cont.)

Auxiliary components, spare and wearing parts



Please note

Spare and wearing parts that have not been tested together with the system can compromise its function. Installing non-authorised components and making non-approved modifications or conversions can compromise safety and may invalidate our warranty.

For replacements, use only original spare parts supplied or approved by Viessmann.

Index

Installation instructions

Preparing for installation

Intended use.....	7
Product information.....	7
Preparing for boiler installation.....	8

Installing the boiler

Removing the front panels.....	12
Siting and levelling the boiler.....	13
Connections on the heating water and the DHW side.....	14
Condensate connection.....	15
Flue gas connection.....	16
Gas connection.....	17
Opening the control unit casing.....	19
Electrical connections.....	20
Closing the control unit casing.....	29
Fitting the front panels.....	31

Service instructions

Commissioning, inspection, maintenance

Steps - commissioning, inspection and maintenance.....	32
Further details regarding the individual steps.....	35

Code 1

Calling up coding level 1.....	77
"General"/group 1.....	78
"Boiler"/group 2.....	80
"DHW"/group 3.....	81
"Heating circuit ..."/group 5.....	81

Code 2

Calling up coding level 2.....	89
"General"/group 1.....	90
"Boiler"/group 2.....	97
"DHW"/group 3.....	99
"Heating circuit ..."/group 5.....	101

Diagnosis and service scans

Service menu.....	111
Diagnosis.....	112
Checking outputs (actuator test).....	118

Index (cont.)

Troubleshooting

Fault display..... 120
 Fault codes..... 122
 Repair..... 137

Function description

Constant temperature control unit..... 149
 Weather-compensated control unit..... 150
 Internal extensions..... 152
 External extensions (accessories)..... 154
 Control functions..... 158
 Allocating heating circuits to the remote control..... 166
 Electronic combustion control unit..... 166

Designs

Internal connection diagram..... 168
 External connection diagram..... 169

Parts lists

Ordering individual parts..... 171
 Overview of the assemblies..... 172
 Casing..... 173
 Hydraulics..... 175
 Primary store..... 178
 Heat cell..... 180
 Control unit..... 183
 Miscellaneous..... 185

Commissioning/service reports..... 187

Specification..... 188

Certificates

Declaration of conformity..... 190
 Manufacturer's certificate according to the 1st BImSchV [Germany]..... 191

Keyword index..... 192

Intended use

The appliance is only intended to be installed and operated in sealed unvented heating systems that comply with EN 12828, with due attention paid to the associated installation, service and operating instructions. It is only designed for the heating of water that is of potable water quality.

Intended usage presupposes that a fixed installation in conjunction with permissible, system-specific components has been carried out.

Commercial or industrial usage for a purpose other than heating the building or DHW does not comply with regulations.

Any usage beyond this must be approved by the manufacturer for the individual case.

Incorrect usage or operation of the appliance (e.g. the appliance being opened by the system user) is prohibited and results in an exclusion of liability. Incorrect usage also occurs if the components in the heating system are modified from their intended function (e.g. if the flue gas and ventilation air paths are sealed).

Product information

Vitodens 222-F, type B2TA

Preset for operation with natural gas E and natural gas LL.
For conversion to LPG P (without conversion kit), see page 44.

In principle the Vitodens 222-F may only be delivered to countries listed on the type plate. For deliveries to alternative countries, an approved contractor must arrange individual approval on his own initiative and in accordance with the law of the country in question.

Preparing for boiler installation

Use a connection set or connection kit, available as an accessory, to make the connection on the gas and water sides.

Fitting accessories

Fit all accessories that are installed from the back of the boiler (e.g. connection sets).



Preparing the connections on site:

Connection set installation instructions.

Or

Assembly kit installation instructions.



Please note

Avoid device damage.

Connect all pipework free of load and torque stress.

The following diagram shows sample connection sets for installation on finished walls to the top or side.

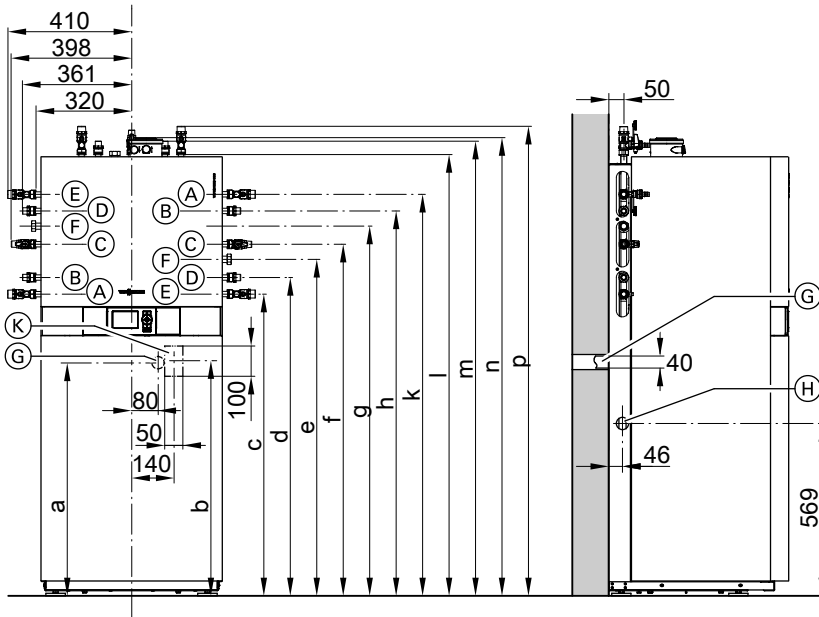

Preparing for boiler installation (cont.)

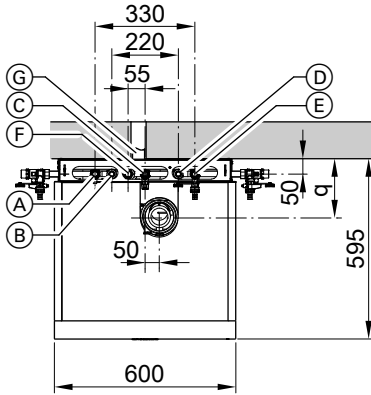

- (A) Heating flow R $\frac{3}{4}$
- (B) DHW R $\frac{1}{2}$
- (C) Gas connection R $\frac{3}{4}$
- (D) Cold water R $\frac{1}{2}$
- (E) Heating return R $\frac{3}{4}$
- (F) DHW circulation R $\frac{1}{2}$ (separate accessory)
- (G) Condensate drain to the back into the wall

- (H) Side condensate drain
- (K) Wiring area

Rated heating output range	3.2 to 26 kW	5.2 to 35 kW
a (mm)	745	945
b (mm)	750	950
c (mm)	972	1172
d (mm)	1027	1227
e (mm)	1082	1302
f (mm)	1137	1337
g (mm)	1191	1391
h (mm)	1247	1447
k (mm)	1302	1562
l (mm)	1437	1637
m (mm)	1466	1666
n (mm)	1465	1665
p (mm)	1526	1726
q (mm)	201	224

Note

All height dimensions have a tolerance of +15 mm due to the adjustable feet.

1. Prepare the heating water connections.
Thoroughly flush the heating system.

Note

Should an additional expansion vessel be required on site, connect this vessel in the heating return.

Preparing for boiler installation (cont.)

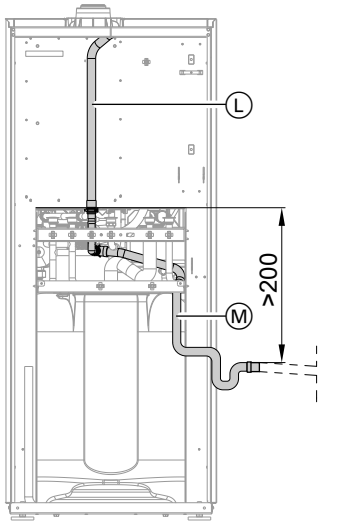

2. Prepare the connections on the DHW side. Install the safety assembly (accessory or on-site provision) in accordance with DIN 1988 and EN 806 in the cold water line (see page 11).

Recommendation:

Install the safety valve above the DHW cylinder to protect it against contamination, scaling and high temperatures.

3. Prepare the condensate connection to the on-site drain line or siphon:
 - Drain towards the back:
See dimensions for condensate hose (M) and position (G) in diagram on page 8.
 - Drain towards the side aperture:
See position (H) in diagram on page 8.
4. Prepare the gas connection according to TRGI or TRF [or local regulations].
5. Prepare the electrical connections.
 - Power cable: NYM-J 3 x 1.5 mm², max. fuse rating 16 A, 230 V/50 Hz.
 - Accessory cables: NYM with the required number of conductors for the external connections.
 - Allow all cables in area (K) in the diagram on page 8 to protrude approx. 2000 mm from the wall.

Preparing for boiler installation (cont.)

Safety assembly in accordance with DIN 1988 and EN 806 to the cold water connection

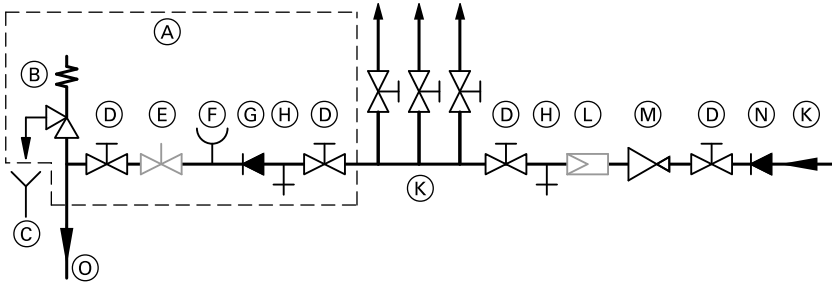

- | | |
|---|---|
| Ⓐ Safety assembly (accessory for the connection sets on unfinished walls) | Ⓖ Non-return valve |
| Ⓑ Safety valve | ⓓ Drain |
| Ⓒ Visible discharge pipe outlet point | Ⓚ Cold water |
| Ⓓ Shut-off valve | Ⓛ Drinking water filter |
| Ⓔ Flow regulating valve (installation recommended) | Ⓜ Pressure reducer to DIN 1988-2, Dec. 1988 issue |
| Ⓕ Pressure gauge connection | Ⓝ Non-return valve/pipe separator |
| | Ⓞ Cold water connection at connection set (accessories) |

Removing the front panels

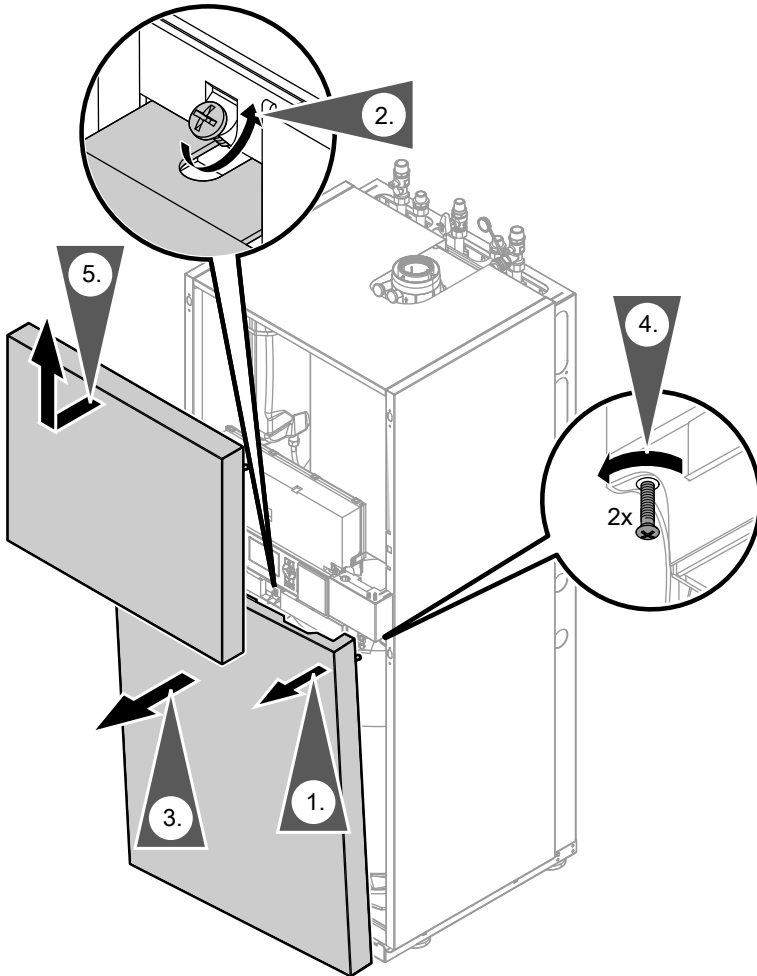

Siting and levelling the boiler

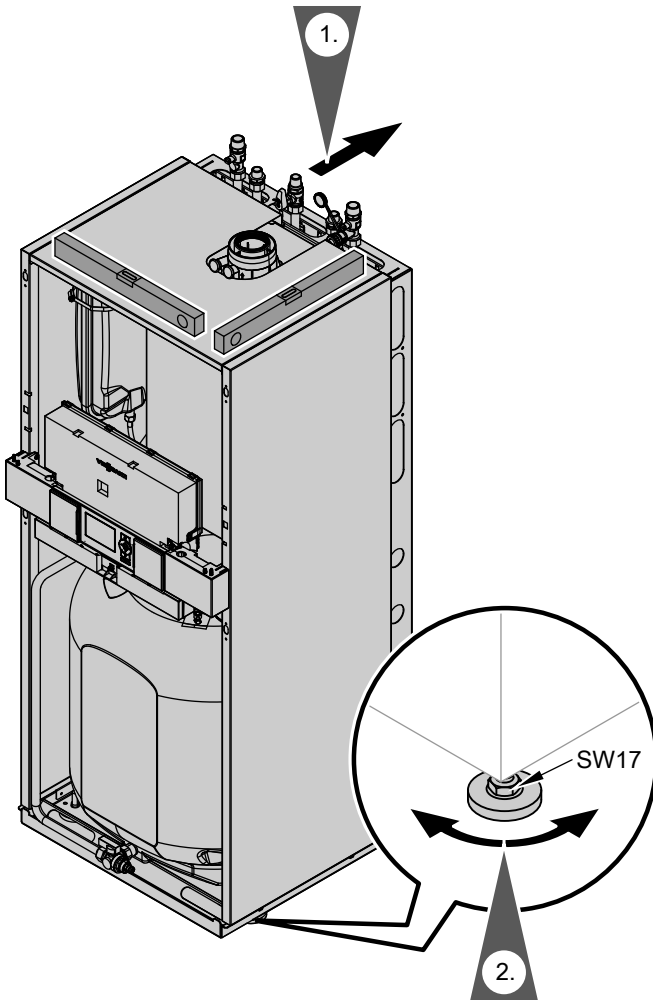

Connections on the heating water and the DHW side

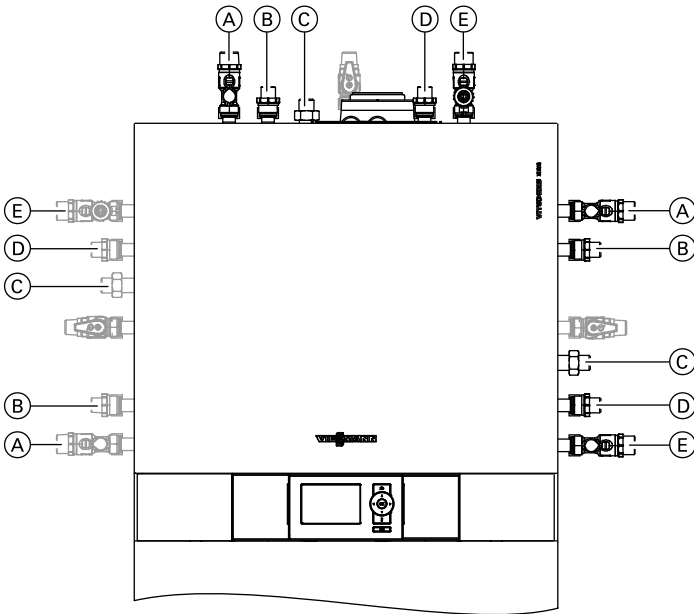

Shown with connection sets for finished walls (accessories)

- (A) Heating flow R $\frac{3}{4}$
- (B) DHW R $\frac{1}{2}$
- (C) DHW circulation R $\frac{1}{2}$ (separate accessory)
- (D) Cold water R $\frac{1}{2}$
- (E) Heating return R $\frac{3}{4}$

Connection on the domestic hot water side

The DHW expansion vessel, available as an accessory, is installed in the cold water supply inside the boiler.



Separate installation instructions

Condensate connection

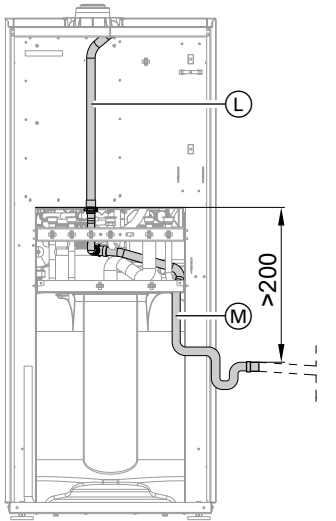

1. If a DHW safety valve is connected, connect hose (L) to the safety valve drain.

Note

If no DHW safety valve is connected, do **not** change the position of hose (L) (serves as a vent).

Only (GB)

- The condensate pipe is connected with the discharge pipe of the safety valve. The condensate hose supplied meets the temperature requirements that are part of the CE certification.
- We recommend the internal connection of the condensate pipe to the domestic drain, either directly or via a tundish.

2. Route condensate hose (M) to the back (drain in wall (G)) or to side aperture (H) (see page 8).

Note

Pull the condensate hose far enough out of the boiler that no unnecessary bends are created inside the boiler.

3. Route condensate hose (M) as a U-bend and connect with a constant fall and a pipe vent to the public sewage system or to a neutralising system. If necessary, connect to an on-site siphon. Ensure this connection is secure.

- If the condensate pipe is routed outside the building, use a pipe with at least \varnothing 30 mm and protect this pipe from frost. Avoid long external pipelines.



Please note

- Frozen condensate pipes can result in faults and damage to the boiler. Always insulate condensate pipes against frost.

- Observe local building regulations.

Condensate connection (cont.)

Observe the local waste water regulations.

Note

Fill the siphon with water before commissioning.

Flue gas connection

Note

- The labels "System certificate" and "Skoberne GmbH flue system" enclosed with the technical documentation may only be used in conjunction with the Viessmann flue system made by Skoberne.
- During installation and positioning of the flue system, observe Part L and BS 5440 building regulations (only **GB**)

Do not carry out **commissioning** until the following conditions are met:

- Free passage through the flue gas pipes.
- Flue system with positive pressure is gas-tight.
- Apertures for ensuring sufficient combustion air supply are open and cannot be closed off.
- Applicable regulations on installing and commissioning flue systems have been followed.



Connecting the balanced flue

Flue system installation instructions



Danger

Leaking or blocked flue systems or an insufficient supply of combustion air cause life threatening poisoning due to carbon monoxide in the flue gas. Ensure the flue system functions correctly. Apertures for combustion air supply must not be able to be closed off.

Gas connection

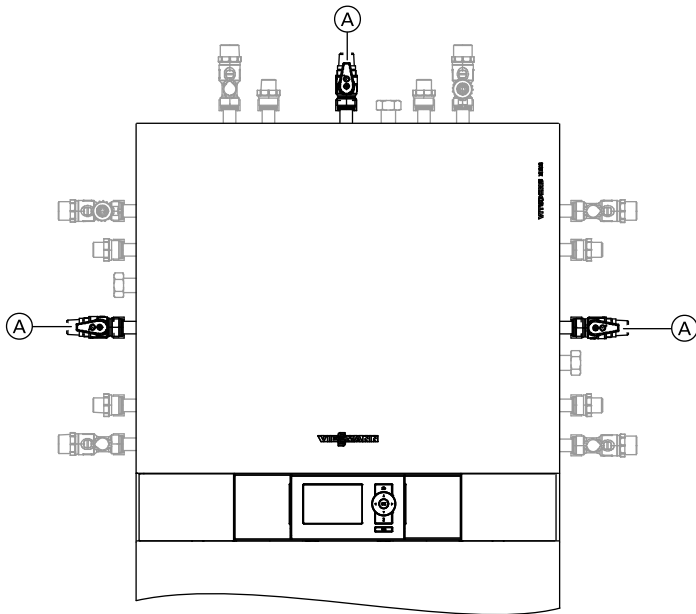

Information on operation with LPG

We recommend the installation of an external safety solenoid valve when installing the boiler in rooms below ground level.

1. Seal gas shut-off valve (A) to the gas connection.

2. Carry out a tightness test.

Note

Only use suitable and approved leak detection agents (EN 14291) and devices for the tightness test. Leak detection agents with unsuitable constituents (e.g. nitrites, sulphides) can cause material damage. Remove residues of the leak detection agent after testing.



Gas connection (cont.)



Please note

Excessive test pressure may damage the boiler and the gas valve.

Max. test pressure 150 mbar (15 kPa). Where higher pressure is required for tightness tests, disconnect the boiler and the gas valves from the gas supply pipe (undo the fitting).

3. Vent the gas line.



Conversion to other gas types:

See page 44.

Opening the control unit casing

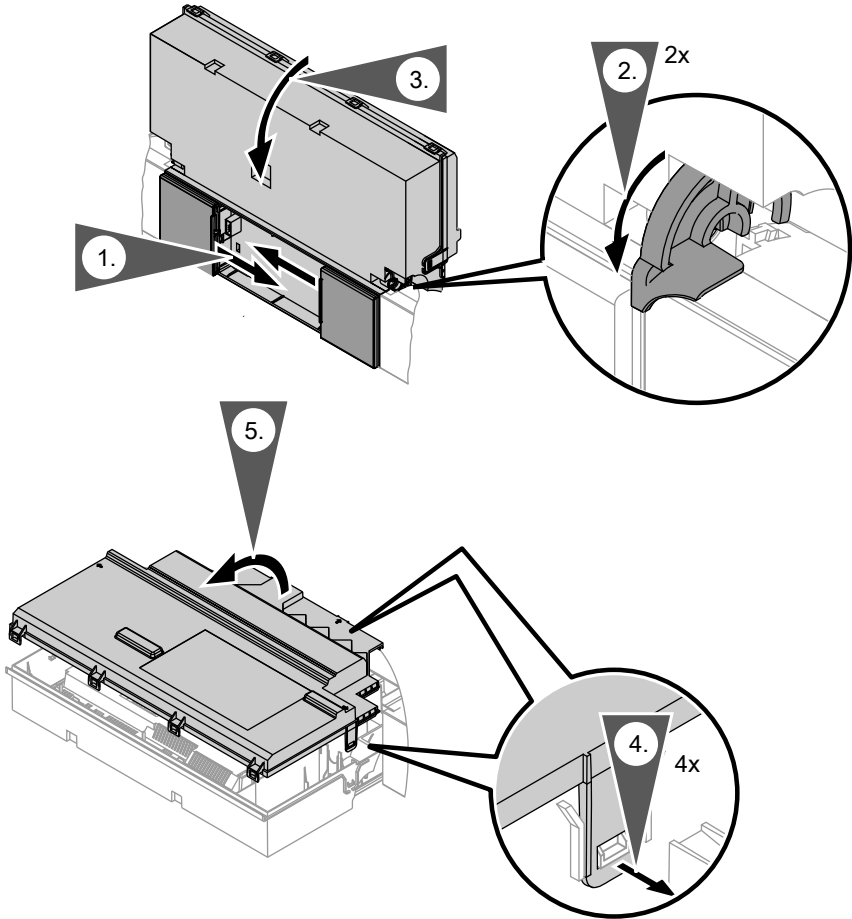

Electrical connections



Please note

Electronic assemblies can be damaged by electrostatic discharge.

Before beginning work, touch earthed objects, such as heating or water pipes, to discharge static loads.

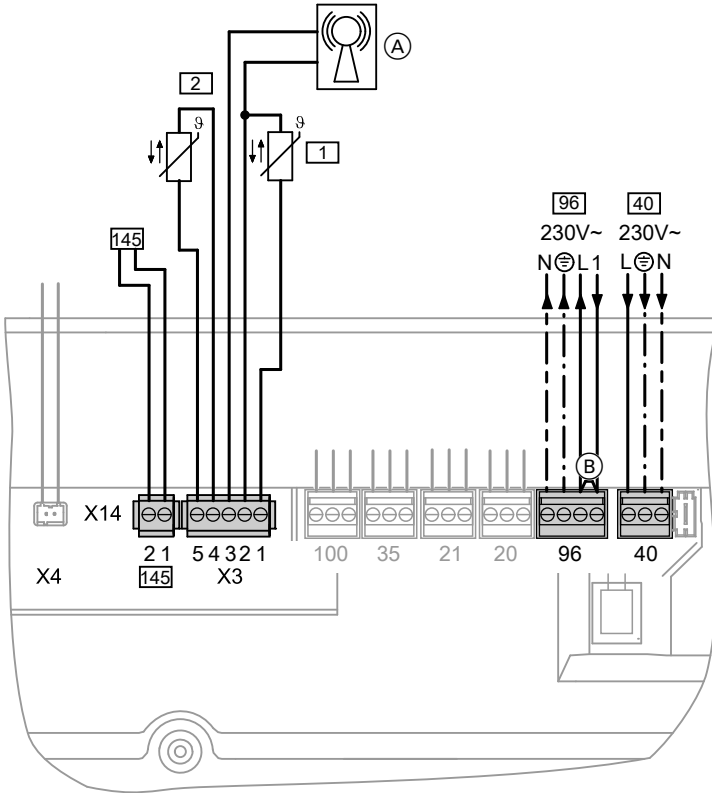

(A) Radio clock receiver

(B) Jumper

Electrical connections (cont.)

Connections at plug 230 V~

- 40 Power supply
- 96
 - Power supply for accessories
 - External demand/blocking
 - Room temperature control unit (remove jumper Ⓑ when making this connection):
 - Vitotrol 100, type UTA
 - Vitotrol 100, type UTDB
 - Vitotrol 100, type UTDB-RF

Connections at LV plug

- X3 Plug X3 can be removed to facilitate installation.
 - 1 Outside temperature sensor
 - 2 Flow temperature sensor for low loss header (accessories)
 - Ⓐ Radio clock receiver
- X4 KM BUS connection, variable speed heating circuit pump (if installed)
- 145 KM BUS subscriber (accessories)
To connect several accessories, see page 25.
 - Vitotrol 200A or 300A remote control
 - Vitocom 100, type GSM
 - Extension kit for one heating circuit with mixer
 - Extension AM1
 - Extension EA1
 - Wireless base station
 - KM BUS distributor

Outside temperature sensor 1

For fitting the wireless outside temperature sensor (wireless accessory):



Wireless base station installation and service instructions



Information on connecting accessories

When connecting accessories observe the separate installation instructions provided with them.

Electrical connections (cont.)

Fitting location for outside temperature sensor

- North or north-western wall, 2 to 2.5 m above ground level; in multi storey buildings, in the upper half of the second floor
- Not above windows, doors or vents

- Not immediately below balconies or gutters
- Never render over

Outside temperature sensor connection

2-core lead, length max. 35 m with a cross-section of 1.5 mm²

External demand via switching contact

Connection options:

- Extension EA1 (accessory, see separate installation instructions).
- Plug [96](#).

Burner operation is load-dependent if the contact is closed. The boiler water is heated to the value set in coding address "9b" in group "**General**"/1. The boiler water temperature is limited by this set value and the electronic maximum limit (coding address "06" in group "**Boiler**"/2).



Please note

'Live' contacts lead to short circuits or phase failure.

The external connection **must be potential-free** and comply with the requirements of safety category II.

Electrical connections (cont.)

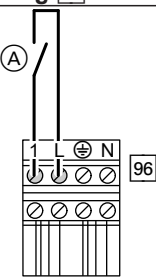
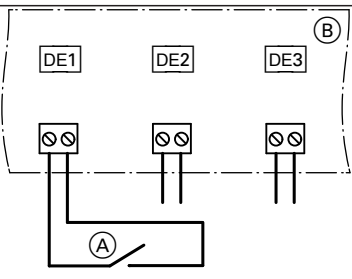
Plug 96	Extension EA1
 <p>(A) Floating contact (when connecting, remove jumper across L and 1)</p>	 <p>(A) Floating contact (B) Extension EA1</p>
<p>Codes</p> <ul style="list-style-type: none"> ■ "4b:1" in group "General"/1. ■ Effect of the function on the relevant heating circuit pump: Coding address "d7" in group "Heating circuit" (only with weather-compensated control units). ■ Effect of the function on the circulation pump for cylinder heating (if installed): Coding address "5F" in group "DHW"/3. 	<p>Codes</p> <ul style="list-style-type: none"> ■ Set "3A" (DE1), "3b" (DE2) or "3C" (DE3) in group "General"/1 to 2. ■ Effect of the function on the relevant heating circuit pump: Coding address "d7" in group "Heating circuit" (only with weather-compensated control units). ■ Effect of the function on the circulation pump for cylinder heating (if installed): Coding address "5F" in group "DHW"/3.

External demand via 0 – 10 V input

Connection at 0 – 10 V input to **extension EA1**.

Ensure DC separation between the earth conductor and the negative pole of the on-site voltage source.

Electrical connections (cont.)

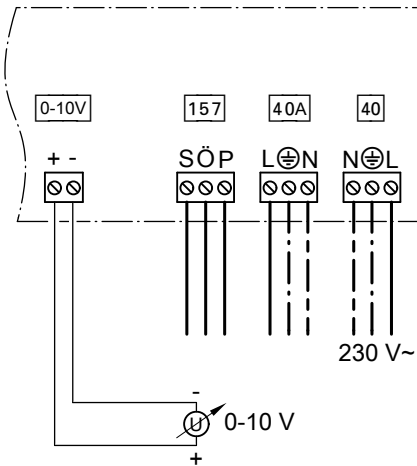

0 – 1 V ≙ No default set boiler water temperature

1 V ≙ Set value 10 °C

10 V ≙ Set value 100 °C

External blocking via switching contact

Connection options:

- Plug 96.
- Extension EA1 (accessory, see separate installation instructions).

The burner is switched off if this contact is closed. The heating circuit pump and (if installed) the circulation pump for cylinder heating are switched according to the set code (see following table "Codes").



Please note

'Live' contacts lead to short circuits or phase failure.

The external connection **must be potential-free** and comply with the requirements of safety category II.

Electrical connections (cont.)

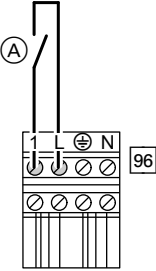
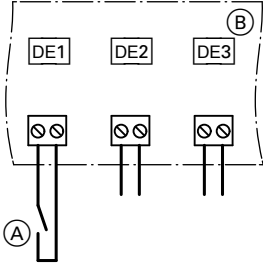
Plug 96	Extension EA1
 <p>(A) Floating contact (when connecting, remove jumper across L and 1)</p>	 <p>(A) Floating contact (B) Extension EA1</p>
<p>Codes</p> <ul style="list-style-type: none"> ■ "4b:2" in group "General"/1 ■ Effect of the function on the heating circuit pump: Coding address "d6" in group "Heating circuit" (only with weather-compensated control units). ■ Effect of the function on the circulation pump for cylinder heating (if installed): Coding address "5E" in group "DHW"/3. 	<p>Codes</p> <ul style="list-style-type: none"> ■ Set "3A" (DE1), "3b" (DE2) or "3C" (DE3) in group "General"/1 to 3 or 4. ■ Effect of the function on the heating circuit pump: Coding address "d6" in group "Heating circuit" (only with weather-compensated control units). ■ Effect of the function on the circulation pump for cylinder heating (if installed): Coding address "5E" in group "DHW"/3.

Power supply for accessories at plug 96 (230 V~)

Where the boiler is installed in a wet area, the power supply connection for accessories must not be made at the control unit. If the boiler is installed outside wet areas, then the power supply connection for accessories can be made directly at the control unit. This connection is switched directly with the ON/OFF switch of the control unit.

If the total system current exceeds 6 A, connect one or more extensions via an ON/OFF switch directly to the mains supply (see next chapter).

Electrical connections (cont.)

Power supply to all accessories via heat source control unit

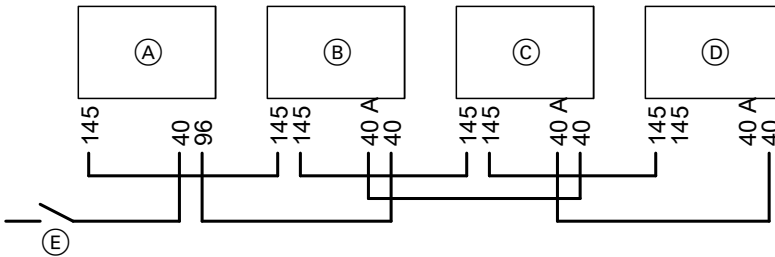

Some accessories with direct power supply

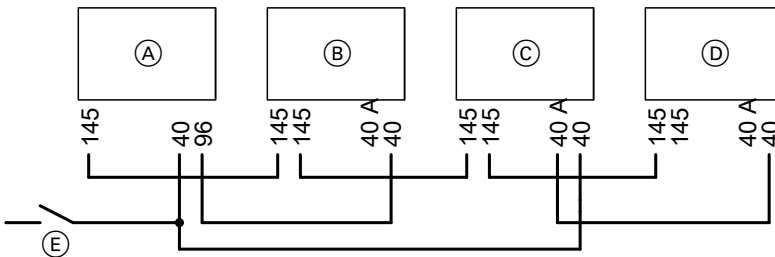

- (A) Heat source control unit
- (B) Extension kit for heating circuit with mixer M2
- (C) Extension kit for heating circuit with mixer M3
- (D) Extensions AM1 or EA1
- (E) ON/OFF switch

The output concerned should only be used to control an on-site relay if the current flowing to the connected working parts (e.g. circulation pumps) is higher than the safety level of the relevant accessory.

Accessories	Internal fuse protection
Extension kit for heating circuit with mixer	2 A
Extension AM1	4 A
Extension EA1	2 A

Electrical connections (cont.)

Power supply 40



Danger

Incorrect core allocation can result in serious injury and damage to the appliance.

Take care not to interchange wires "L1" and "N".

- Remove existing wires from plug 40.

- Install an isolator in the power cable which simultaneously separates all non-earthed conductors from the mains with contact separation of at least 3 mm.

In addition, we recommend the installation of an AC/DC-sensitive RCD (RCD class B ) for DC (fault) currents that can be created by energy efficient equipment.

- Max. fuse rating 16 A.

Electrical connections (cont.)

Routing the connecting cables



Please note

Connecting cables will be damaged if they touch hot components.

When routing and securing cables/leads on site, ensure that the maximum permissible temperatures for these cables/leads are not exceeded.

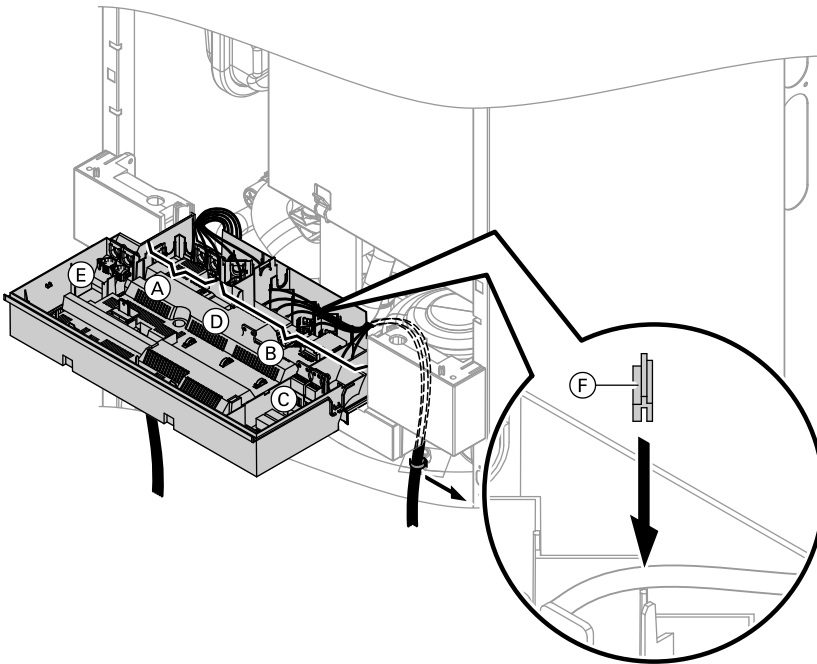

- (A) LV connections
- (B) 230 V connections
- (C) Internal extension
- (D) Main PCB

- (E) Communication module (accessories)
- (F) Cable grommet for power cable

Closing the control unit casing

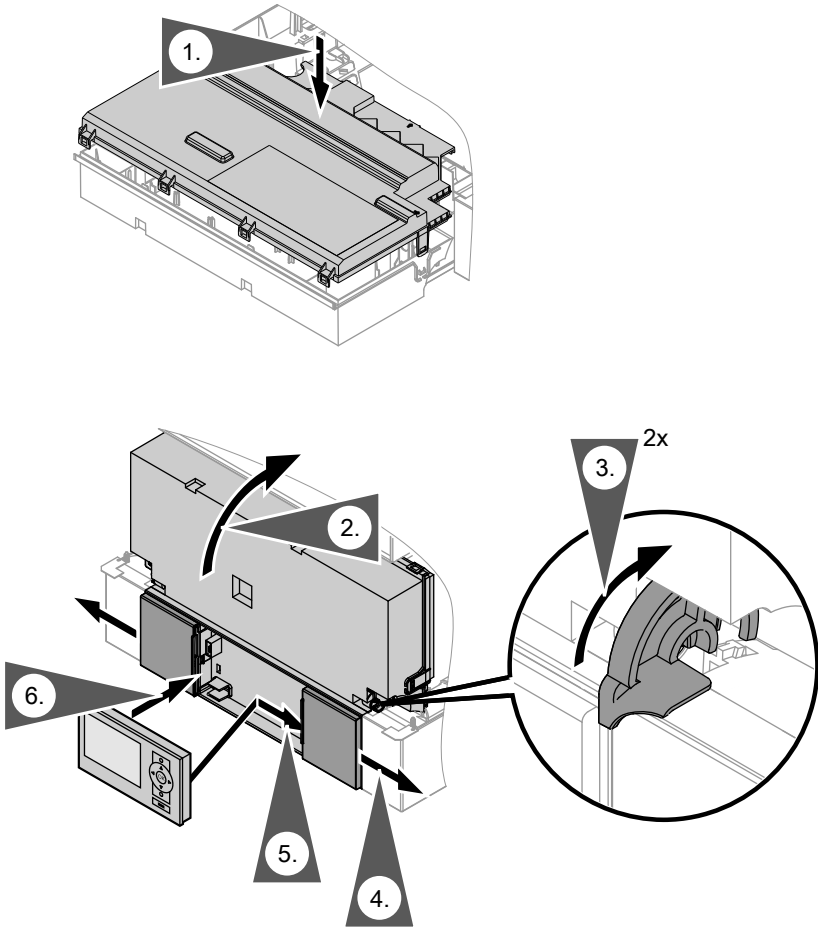

Closing the control unit casing (cont.)

Insert programming unit (packed separately) into the control unit support.

Note

The programming unit can also be inserted into a wall mounting base (accessories) near the boiler.



Wall mounting base installation instructions

Fitting the front panels

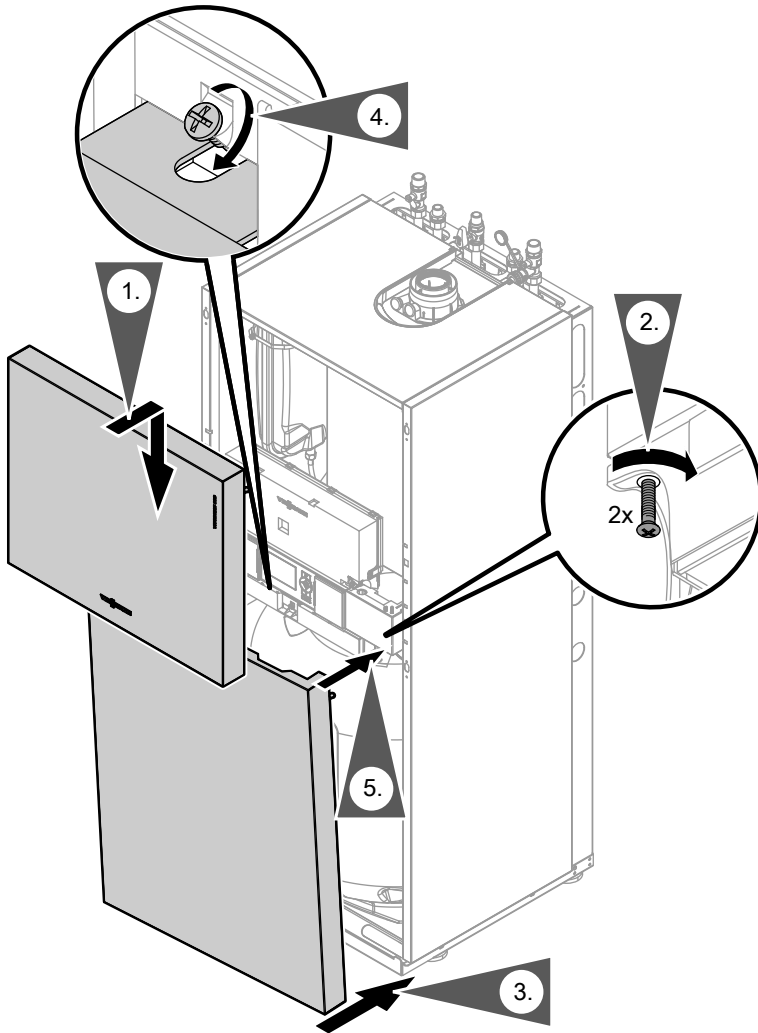

Steps - commissioning, inspection and maintenance

For further information regarding the individual steps, see the page indicated

				Page
			Commissioning steps	
			Inspection steps	
			Maintenance steps	
			1. Removing the front panels.....	35
•	•	•	2. Checking the power supply	
•			3. Filling the heating system.....	35
•			4. Filling the DHW cylinder on the DHW side.....	37
•			5. Switching on the power supply and ON/OFF switch	
•			6. Selecting the language - only for weather-compensated control units.....	37
•	•		7. Setting the time and date - only for weather-compensated control units.....	38
•			8. Note on automatic testing of the flue gas temperature sensor.....	38
•			9. Venting the boiler.....	39
•			10. Venting the heating system.....	40
•			11. Filling the siphon with water.....	42
•	•	•	12. Checking all connections on the heating water side and DHW side for leaks	
•			13. Designating heating circuits - only for weather-compensated control units.....	43
•	•		14. Checking the gas type.....	43
•			15. Gas type conversion (only for operation with LPG)....	44
•	•	•	16. Checking the static and supply pressure.....	44
•	•	•	17. Function sequence and possible faults.....	46
•			18. Max. heating output setting.....	48
•			19. Tightness test, balanced flue system (annular gap check).....	49
		•	20. Burner removal.....	50

Steps - commissioning, inspection and maintenance

				Page
			Commissioning steps	
			Inspection steps	
			Maintenance steps	
	•	•	21. Checking the burner gasket and burner gauze assembly	51
	•	•	22. Checking and adjusting the ignition and ionisation electrodes	52
		•	23. Cleaning the heating surfaces	52
	•	•	24. Checking the condensate drain and cleaning the siphon	53
	•	•	25. Installing the burner	55
	•	•	26. Checking the neutralising system (if installed)	
•			27. Checking the anode connection	56
		•	28. Checking the anode earth current with an anode tester	56
		•	29. Draining the boiler on the DHW side	58
		•	30. Cleaning the primary store	59
		•	31. Checking and replacing the magnesium anode (if required)	60
		•	32. Re-assembling and filling the primary store	60
•	•	•	33. Checking the expansion vessel and system pressure	61
		•	34. Checking the pre-charge pressure and the DHW expansion vessel (if installed)	62
•	•	•	35. Checking the function of safety valves	
•	•	•	36. Checking firm seating of electrical connections	
•	•	•	37. Checking all gas equipment for tightness at operating pressure	62
•		•	38. Checking the combustion quality	63
•	•	•	39. Checking the external LPG safety valve (if installed)	
•			40. Matching the control unit to the heating system	64
•			41. Adjusting the heating curves (only for weather-compensated control units)	70

Steps - commissioning, inspection and... (cont.)

		Page
	Commissioning steps	
	Inspection steps	
	Maintenance steps	
•	42. Connecting the control unit to the LON.....	73
•	43. Scanning and resetting the "Service" display.....	75
•	44. Fitting the cover panel and front panels.....	76
•	45. Instructing the system user.....	76

Further details regarding the individual steps

Removing the front panels

See page 12

Filling the heating system

Fill water



Please note

Unsuitable fill water increases the level of deposits and corrosion and may lead to boiler damage.

- Flush the heating system thoroughly before filling.
- Only use fill water of potable quality.
- An antifreeze additive suitable for heating systems can be added to the fill water. The antifreeze manufacturer must verify its suitability.
- Fill and top-up water with a water hardness in excess of the following values must be softened, e.g. with a small softening system for heating water.

Total permissible hardness of the fill and top-up water

Total heating output kW	Specific system volume (Conversion rate 1 mol/m ³ = 100 ppm)		
	< 20 l/kW	≥ 20 l/kW to < 50 l/kW	≥ 50 l/kW
≤ 50	≤ 3.0 mol/m ³	≤ 2.0 mol/m ³	< 0.02 mol/m ³
> 50 to ≤ 200	≤ 2.0 mol/m ³	≤ 1.5 mol/m ³	< 0.02 mol/m ³
> 200 to ≤ 600	≤ 1.5 mol/m ³	≤ 0.02 mol/m ³	< 0.02 mol/m ³
> 600	< 0.02 mol/m ³	< 0.02 mol/m ³	< 0.02 mol/m ³

Further details regarding the individual steps (cont.)

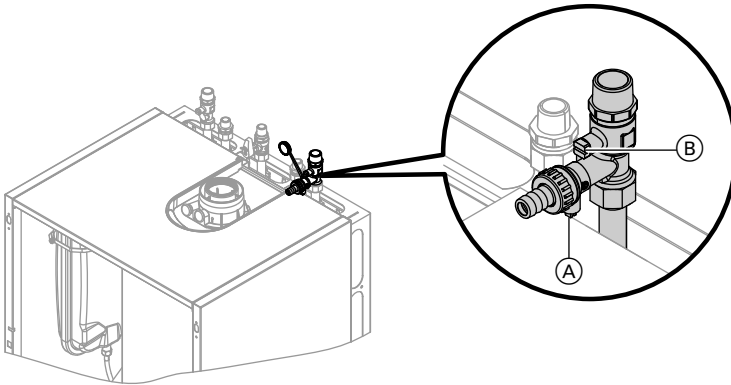

Shown with connection set for finished walls (accessories)

1. Check the pre-charge pressure of the diaphragm expansion vessel (see page 61).
2. Close the gas shut-off valve.
3. Open shut-off valves (B) on the heating water side.
4. Fill the heating system via boiler drain & fill valve (A) in the heating return (at the connection set on the side or above the boiler). Minimum system pressure > 1.0 bar (0.1 MPa).
5. If the control unit had already been switched on before filling began: Switch control unit ON and activate fill program (see next chapter).
6. Close boiler drain & fill valve (A).

Note

For function and details of the fill program, see page 161.

Note



If the control unit has not been switched on prior to filling the system, then the servomotor of the diverter valve will still be in its central position, and the system will be completely filled.

Further details regarding the individual steps (cont.)

Activating the filling function



Weather-compensated control unit

Service menu

1. Press **OK** and  simultaneously for approx. 4 s.
2. **"Service functions"**
3. **"Filling"**
Filling function is enabled.
4. Ending filling function:
Press **OK** or .

Constant temperature control unit

Service menu

1. Press **OK** and  simultaneously for approx. 4 s.
2. Select "**4**" and confirm with **OK**.
"ON" flashes.
3. Activate the filling function with **OK**.
"bF on" is shown constantly.
4. Ending filling function:
Press .

Filling the DHW cylinder on the DHW side

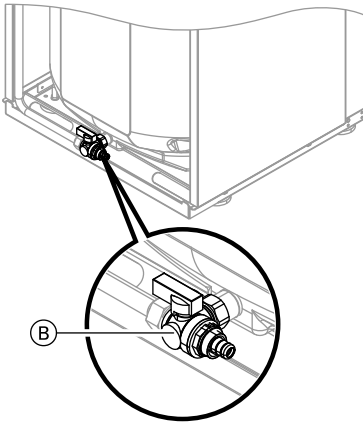

1. Lever on valve **(B)** must be in the "left" position.
2. Open on-site DHW supply and a DHW draw-off point.
3. Once air stops coming out of the DHW draw-off point, the DHW cylinder is completely filled.

Selecting the language - only for weather-compensated control units

At the commissioning stage, the display is in German (factory setting).

Extended menu:

1. 
2. **"Einstellungen"**

3. **"Sprache"**
4. Select the required language with **▲**
▼.

Further details regarding the individual steps (cont.)

Sprache	
Deutsch	DE <input checked="" type="checkbox"/>
Bulgarski	BG <input type="checkbox"/>
Cesky	CZ <input type="checkbox"/>
Dansk	DK <input type="checkbox"/>
Wählen mit 	

Setting the time and date - only for weather-compensated control units

The time and date need to be reset during commissioning or after a prolonged time out of use.

3. **"Time/Date"**

4. Set current time and date.

Extended menu:

1. 

2. **"Settings"**

Note on automatic testing of the flue gas temperature sensor

Weather-compensated control unit

As soon as the time and date have been set, the control unit automatically checks the function of the flue gas temperature sensor.

The display shows: **"Flue gas temp sensor test"** and **"Active"**.

Note

If the flue gas temperature sensor is incorrectly positioned, commissioning will be cancelled and fault message A3 shown (see page 144).

Constant temperature control unit

Immediately after being switched on, the control unit automatically checks the function of the flue gas temperature sensor. The display shows: **"A"**.

Note

If the flue gas temperature sensor is incorrectly positioned, commissioning will be cancelled and fault message A3 shown (see page 144).

Further details regarding the individual steps (cont.)

Venting the boiler

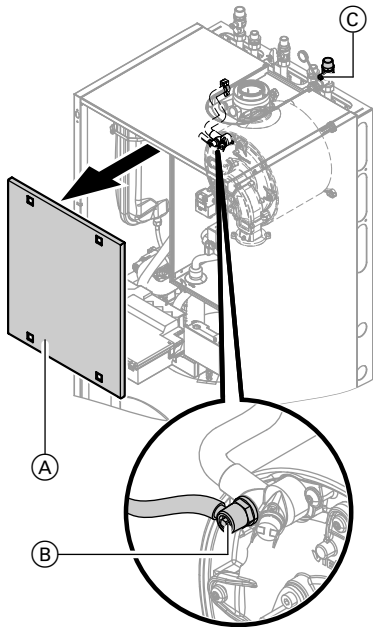

1. Close the shut-off valves on the heating water side.
2. Remove cover panel (A).
3. Push the drain hose onto air vent valve (B) and connect to a drain.
4. Open air vent valve (B) and fill valve (C) in the heating return and vent using mains pressure (flush) until no more air noise can be heard.
5. First close air vent valve (B).
6. When the required operating pressure has built up, close fill valve (C). Open the shut-off valves on the heating water side.
7. Remove drain hose from air vent valve (B) and retain.

Further details regarding the individual steps (cont.)

Venting the heating system

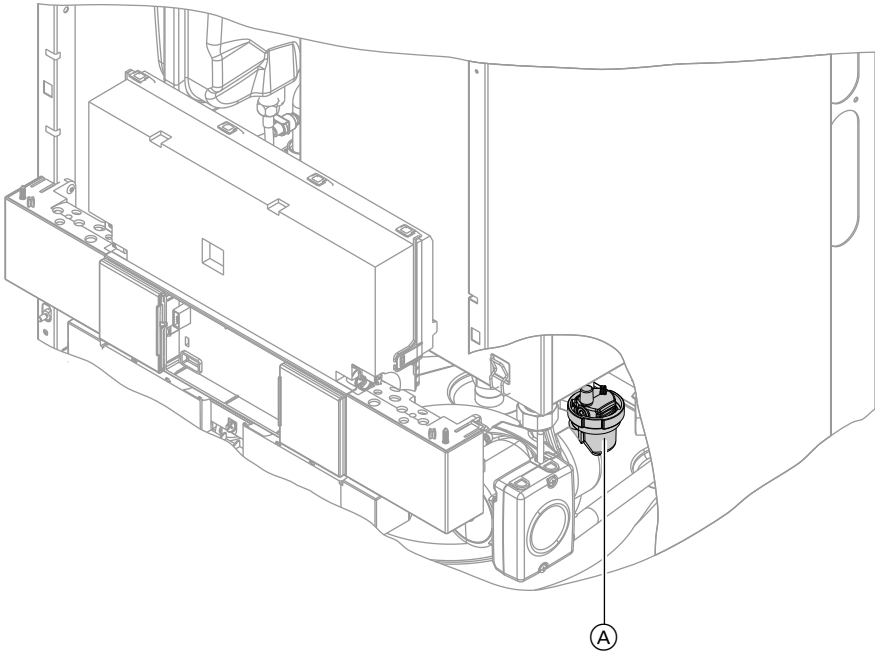

1. Close the gas shut-off valve and switch the control unit ON.
2. Check whether the air vent screw in quick-action air vent valve (A) in the heating circuit pump is open.
3. Activate venting program (see following steps).
4. Check the system pressure.
5. Open the gas shut-off valve.

Note



For function and sequence of the venting program, see page 160.

Further details regarding the individual steps (cont.)

Activating the venting function



Weather-compensated control unit

Service menu

1. Press **OK** and  simultaneously for approx. 4 s.
2. **"Service functions"**
3. **"Venting"**
Venting function is enabled.
4. Ending venting function:
Press **OK** or .

Constant temperature control unit

Service menu

1. Press **OK** and  simultaneously for approx. 4 s.
2. Select "**5**" with  and confirm with **OK**.
"ON" flashes.
3. Activate the venting function with **OK**.
"EL on" is shown constantly.
4. Ending venting function:
Press .

Further details regarding the individual steps (cont.)

Filling the siphon with water

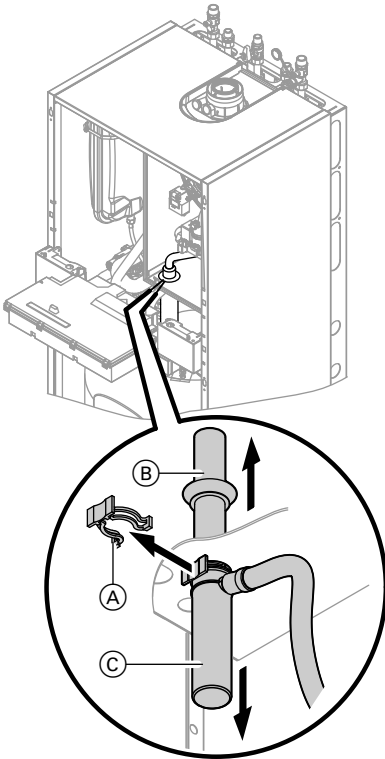

1. Pivot control unit forward.
2. Remove retaining clip (A).
3. Pull filler pipe (B) upwards.
4. Remove trap (C) downwards.
5. Fill siphon with water and reassemble.
6. Check that the condensate pipe is connected correctly to the siphon and heat exchanger.
7. Refit cover panel.
8. Secure control unit back in operating position.

Note

Route the drain hose without any bends and with a constant fall.

Further details regarding the individual steps (cont.)

Designating heating circuits - only for weather-compensated control units

In the delivered condition, the heating circuits are designated "**Heating circuit 1**", "**Heating circuit 2**" and "**Heating circuit 3**" (if installed).

If the system user prefers, the heating circuits can be designated differently to suit the specific system.



Enter names for heating circuits:

Operating instructions

Checking the gas type

The boiler is equipped with an electronic combustion controller that adjusts the burner for optimum combustion in accordance with the prevailing gas quality.

- For operation with natural gas no adjustment is therefore required across the entire Wobbe index range. The boiler can be operated in the Wobbe index range 9.5 to 15.2 kWh/m³ (34.2 to 54.7 MJ/m³).
- Convert the burner for operation with LPG (see "Gas type conversion" on page 44).

1. Determine the gas type and Wobbe index by asking your local gas supply utility or LPG supplier.
2. Convert the burner for operation with LPG (see page 44).
3. Record the gas type in the report on page 187.

Further details regarding the individual steps (cont.)

Gas type conversion (only for operation with LPG)

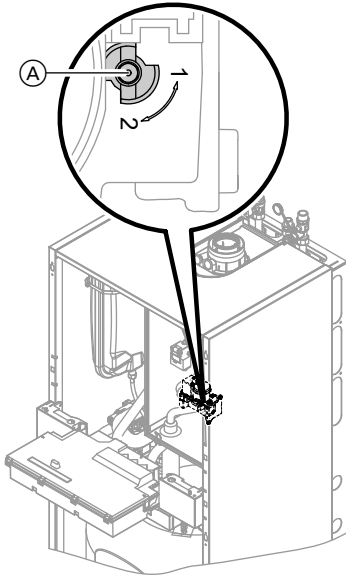

1. Set adjusting screw (A) on the gas train to "2".
2. Switch ON/OFF switch (D) ON.
3. Select the gas type in coding address "82".
 - Call up code 2
 - **"General"** (weather-compensated control unit)
or
Group 1 (constant temperature control unit) – call up.
 - Select coding address "11" and value "9". Confirm with **OK**. The display shows "11:0".
 - Select coding address "82" and value "1" (LPG operation). Confirm with **OK**.
 - Select coding address "11" and value ≠ "9". Confirm with **OK**. The display shows "11:0".
 - End service functions.
4. Open the gas shut-off valve.
5. Affix label "G31" (supplied with the technical documentation) next to the type plate.

Checking the static and supply pressure



Danger

CO build-up as a result of incorrect burner adjustment can have serious health implications. Carry out a CO test before and after work on gas appliances.

Operation with LPG

Flush the LPG tank twice during commissioning or replacement. Vent the tank and gas connection line thoroughly after flushing.

Further details regarding the individual steps (cont.)

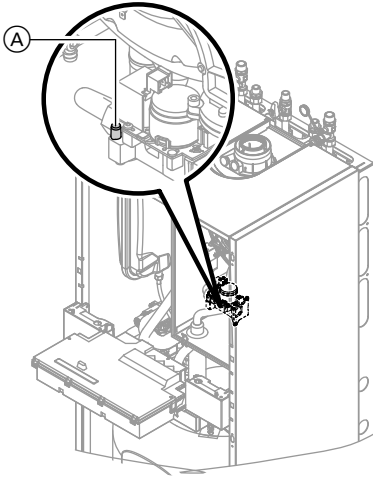

1. Close the gas shut-off valve.
 2. Undo screw (A) inside test nipple "PE" on the gas train, but do not remove it, and connect the pressure gauge.
 3. Open the gas shut-off valve.
 4. Check the static pressure and record the actual value in the report on page 187.
Set value: max. 57.5 mbar (5.75 kPa).
 5. Start the boiler.
- Note**
During commissioning, the boiler can enter a fault state (fault EE is displayed) because of air in the gas line. After approx. 5 s, press reset button R to reset the burner.
6. Check the supply (flow) pressure.

Set value:
 - Natural gas: 20 mbar (2.0 kPa)
 - LPG: 50 mbar (5.0 kPa)

Note
Use a suitable measuring device with a resolution of at least 0.1 mbar (0.01 kPa) to check the supply pressure.
 7. Record the actual value in the report on page 187.
Take the action shown in the following table.
 8. Shut down the boiler, close the gas shut-off valve, remove the pressure gauge and close test nipple (A) with the screw.
 9. Open the gas shut-off valve and start the appliance.



Danger

Gas escaping from the test nipple leads to a risk of explosion.

Check gas tightness at test nipple (A).

Further details regarding the individual steps (cont.)

Supply pressure (flow pressure)		Action
For natural gas	For LPG	
Below 17.4 mbar (1.74 kPa)	Below 42.5 mbar (4.25 kPa)	Do not start the boiler. Notify your gas supply utility or LPG supplier.
17.4 to 25 mbar (1.74 to 2.5 kPa)	42.5 to 57.5 mbar (4.25 to 5.75 kPa)	Start the boiler.
Above 25 mbar (2.5 kPa)	Above 57.5 mbar (5.75 kPa)	Install a separate gas pressure governor upstream of the system and regulate the pre-charge pressure to 20 mbar (2.0 kPa) for natural gas or 50 mbar (5.0 kPa) for LPG. Notify your gas supply utility or LPG supplier.

Function sequence and possible faults

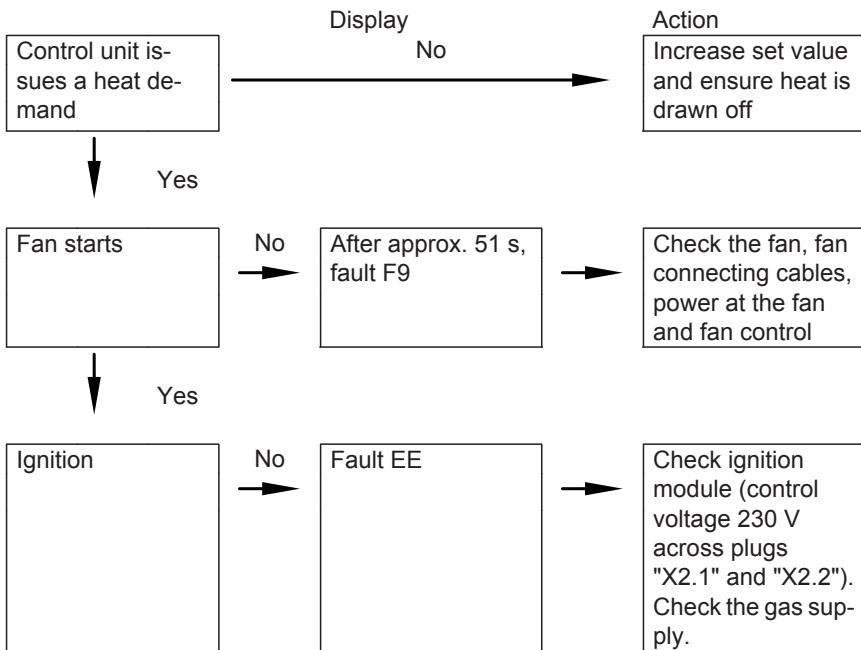

Further details regarding the individual steps (cont.)

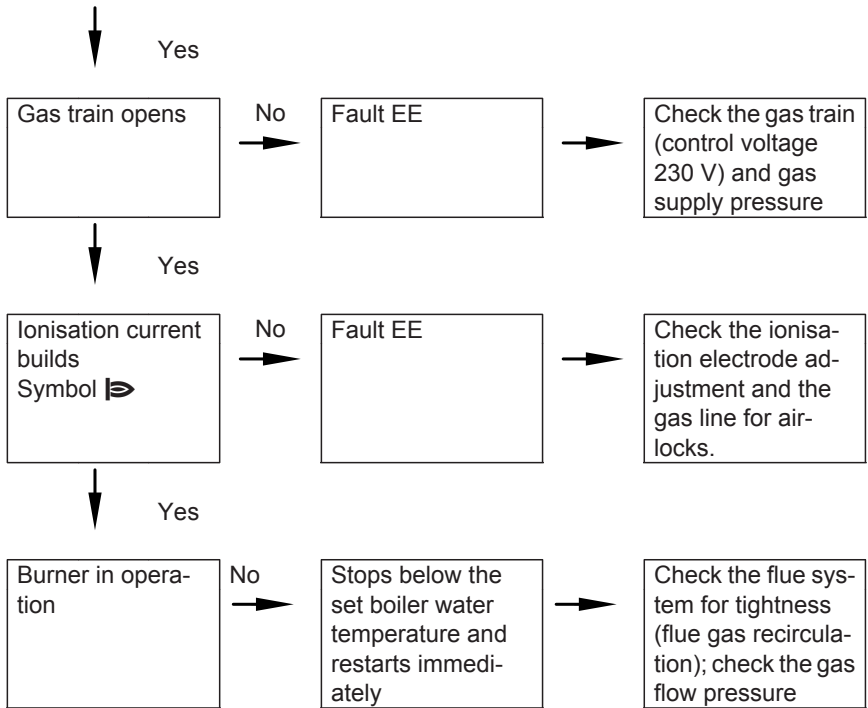

Further details regarding the individual steps (cont.)

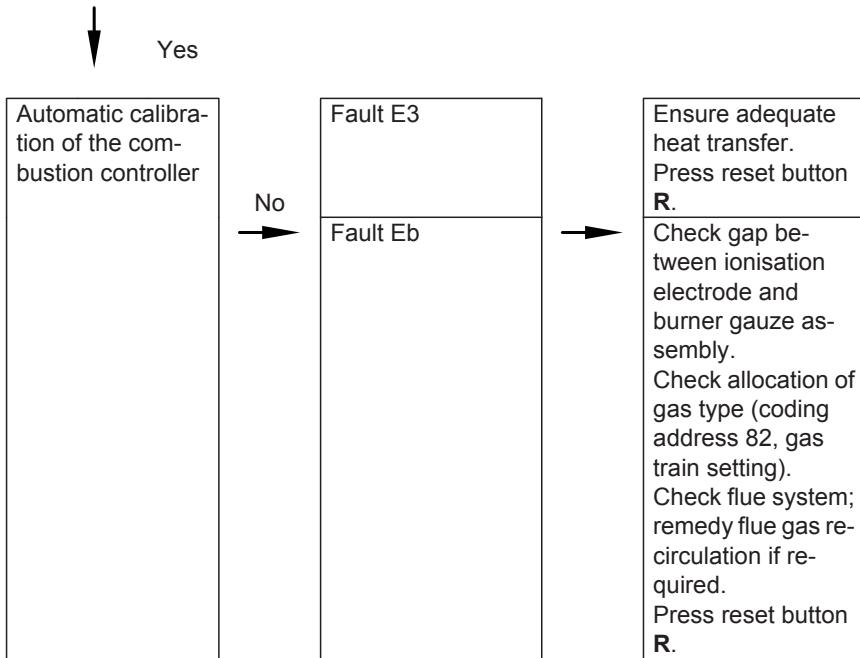

For further details on faults, see page 120.

Max. heating output setting

The maximum output for **heating operation** can be limited. The limit is set via the modulation range. The max. adjustable heating output is limited upwards by the boiler coding card.

Further details regarding the individual steps (cont.)

Weather-compensated control unit

Service menu

1. Press **OK** and **≡** simultaneously for approx. 4 s.
2. **"Service functions"**
3. **"Max. output"**
4. **"Change?"** Select **"Yes"**.
A value is shown on the display (e.g. **"85"**). In the delivered condition, this value represents 100 % of rated heating output.
5. Set the required value.

Constant temperature control unit

Service menu

1. Press **OK** and **≡** simultaneously for approx. 4 s.
2. Select **"③"** with **▶** and confirm with **OK**.
A value flashes on the display (e.g. **"85"**) and **"▶"** appears. In the delivered condition, this value represents 100 % of rated heating output.
3. Select required value and confirm with **OK**.

Tightness test, balanced flue system (annular gap check)

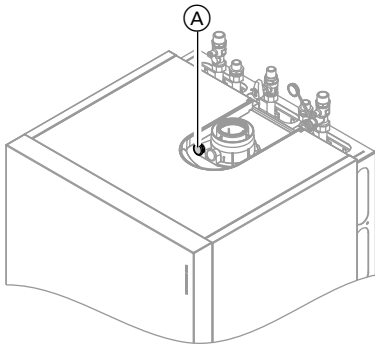

- Ⓐ Combustion air aperture (ventilation air)

For balanced flue systems tested together with the wall mounted gas fired boiler, the requirement for a tightness test during commissioning by the flue gas inspector is not applicable.

We recommend that your heating engineer carries out a simple leak/tightness test during the commissioning of your system. For this, it would be sufficient to check the CO₂ or O₂ concentration in the combustion air at the annular gap of the balanced flue pipe.

The flue pipe is deemed to be gas-tight if the CO₂ concentration in the combustion air is no higher than 0.2 % or the O₂ concentration is at least 20.6 %.

If actual CO₂ values are higher or O₂ values are lower, then pressure test the flue pipe with a static pressure of 200 Pa.

Further details regarding the individual steps (cont.)

Burner removal

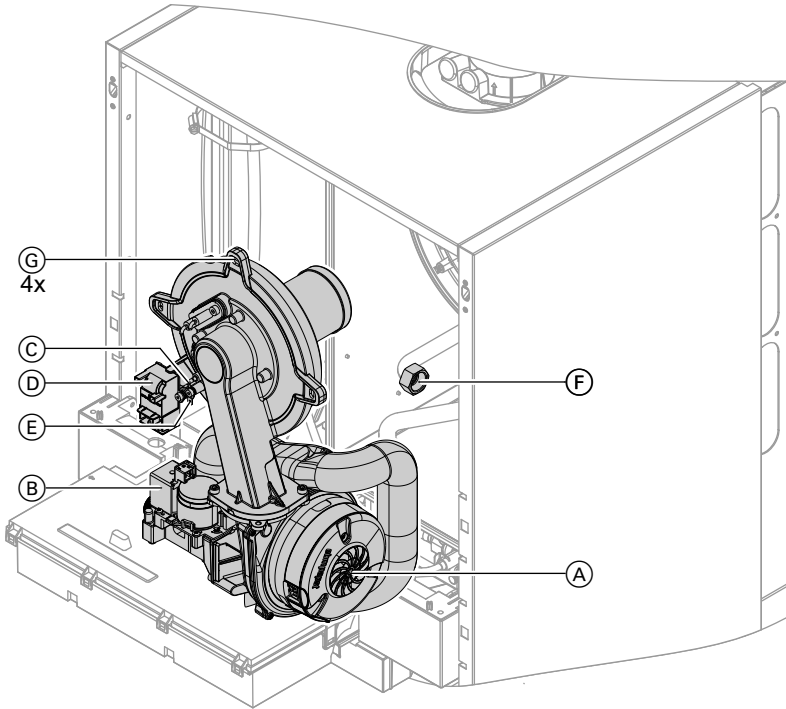

1. Switch OFF the power supply and the ON/OFF switch at the control unit.
2. Close the gas shut-off valve and safeguard against reopening.
3. Remove cables from fan motor (A), gas train (B), ignition and ionisation electrode (C), ignition unit (D) and earth tab (E).
4. Undo gas supply pipe fitting (F).
5. Undo four screws (G) and remove the burner.



Please note

Prevent damage to the burner.
Never rest the burner on the burner gauze assembly.

Further details regarding the individual steps (cont.)

5. Fit thermal insulation ring (D).

6. Fit electrodes (B).
Torque: 4.5 Nm.

Checking and adjusting the ignition and ionisation electrodes

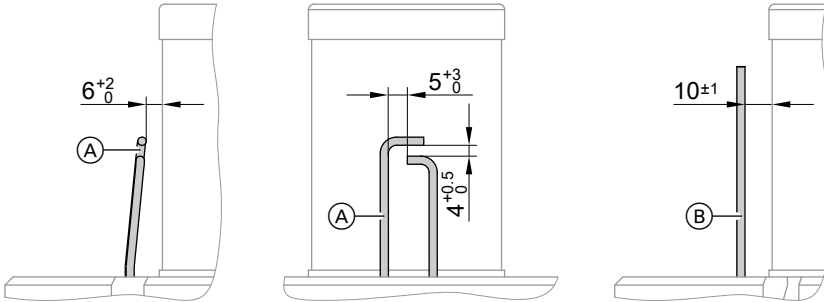

(A) Ignition electrodes

(B) Ionisation electrode

1. Check the electrodes for wear and contamination.
2. Clean the electrodes with a small brush (not with a wire brush) or sandpaper.
3. Check the electrode gaps. If the gaps are not as specified or the electrodes are damaged, replace the electrodes together with new gaskets and adjust them as required. Tighten the electrode fixing screws with 4.5 Nm.

Cleaning the heating surfaces

! **Please note**
There should be no scratches or other damage on the heat exchanger surface that comes into contact with hot gases. This could lead to corrosion damage.

Never use brushes to clean the heating surfaces.

Brushing can cause existing deposits to get stuck in the coil gaps.

Note
*Discolouration of the heat exchanger surface is a normal sign of usage. It has no impact on the function and service life of the heat exchanger.
The use of chemical cleaning agents is not necessary.*

Further details regarding the individual steps (cont.)

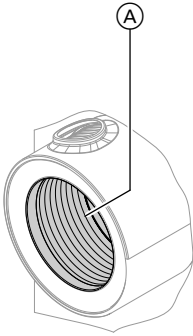

1. Use a vacuum cleaner to remove deposits from heating surfaces (A) of the heat exchanger.
2. If required, rinse heating surfaces (A) with water.
3. Check condensate drain and clean siphon. See the following chapter.

Checking the condensate drain and cleaning the siphon

Flue gas cascade:

Clean the siphon in the flue gas header as well.

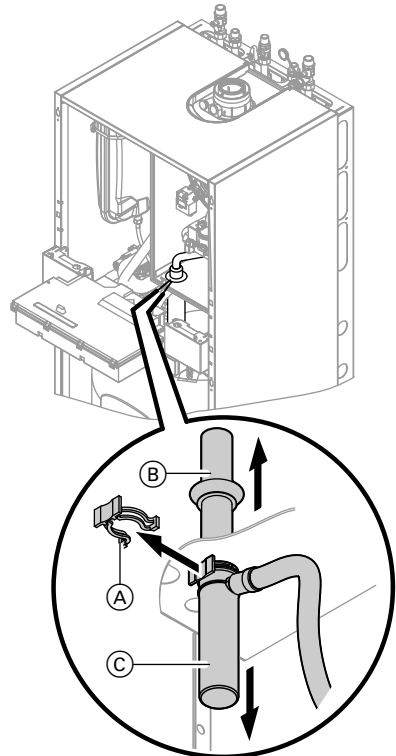

Further details regarding the individual steps (cont.)

1. Check at the siphon that the condensate can drain freely.
2. Remove retaining clip (A).
3. Pull filler pipe (B) upwards.
4. Remove trap (C) downwards.
5. Remove the condensate hose from trap (C).
6. Clean the siphon.
7. Fill siphon with water and reassemble with retaining clip (A).
8. Check that the condensate pipe is connected correctly to the siphon and heat exchanger.

Note

Route the drain hose without any bends and with a constant fall.

Further details regarding the individual steps (cont.)

Installing the burner

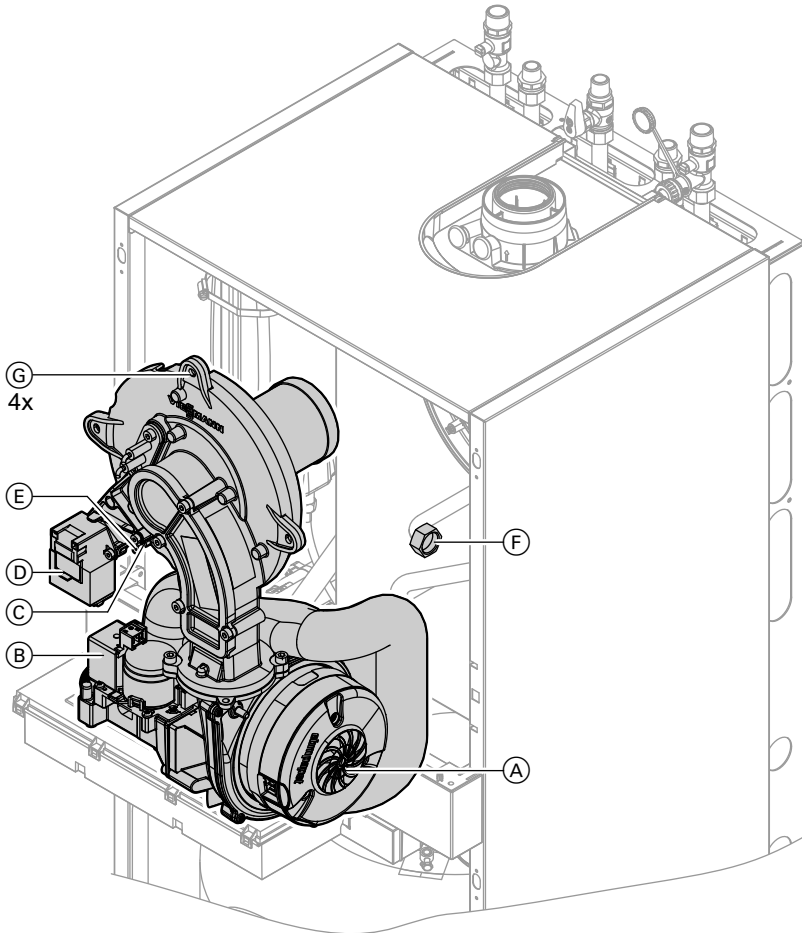

1. Install the burner and tighten screws **(G)** diagonally with 8.5 Nm.
2. Fit gas supply pipe **(F)** with a new gasket.
3. Check the gas connections for tightness.

Further details regarding the individual steps (cont.)



Danger

Escaping gas leads to a risk of explosion.
Check all fittings for gas tightness.

4. Connect cables from fan motor (A), gas train (B), ionisation electrode (C), ignition unit (D) and earth tab (E).

Checking the anode connection

Check that the earth cable is connected to the magnesium anode.

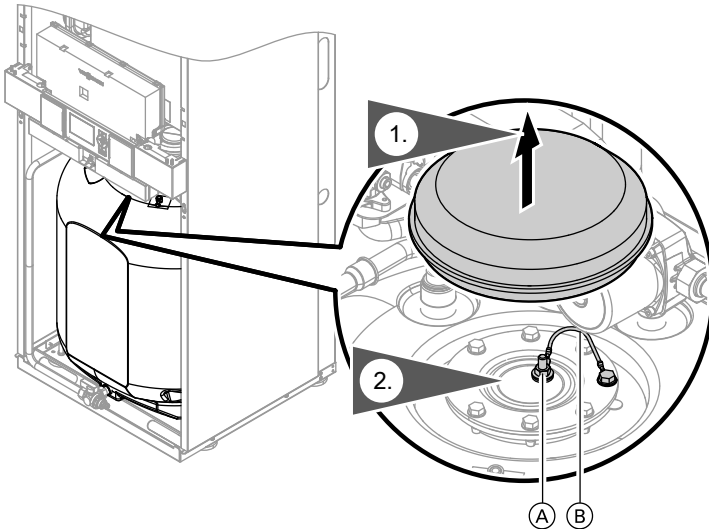

(A) Magnesium anode

(B) Earth cable

Checking the anode earth current with an anode tester

Note

We recommend that the magnesium anode function is checked annually. This function test can be carried out without interrupting operation, by measuring the earth current with an anode tester.

Further details regarding the individual steps (cont.)

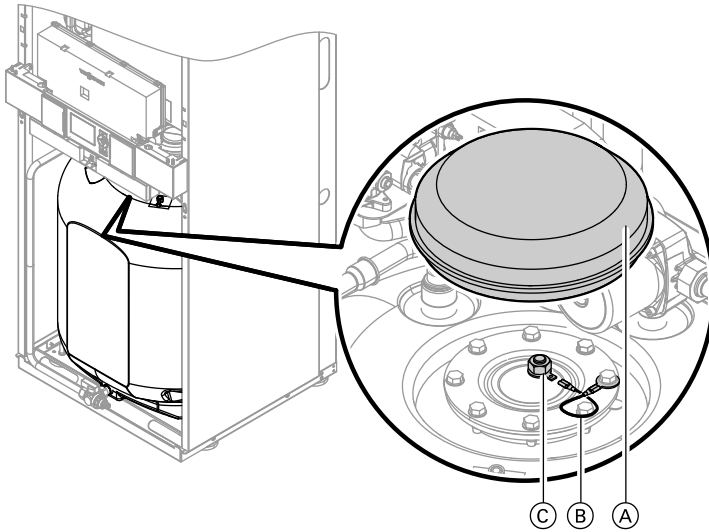

1. Remove cover (A).
2. Remove earth cable (B) from tab (C).
3. Connect tester (up to 5 mA) in series between tab (C) and earth cable (B).
 - If the current measures > 0.3 mA, the anode is OK.
 - If the current measures < 0.3 mA or if there is no current at all, inspect the anode visually (see page 60).

Further details regarding the individual steps (cont.)

Draining the boiler on the DHW side

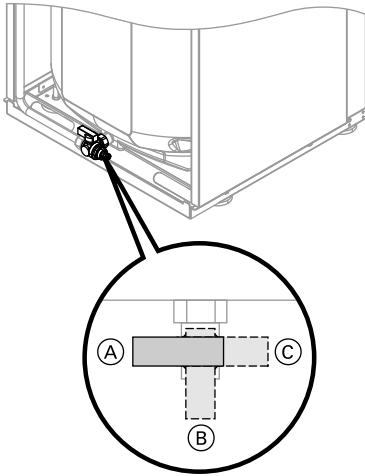

1. Connect hose to drain valve and route into a suitable container or drain outlet.

Note

Ensure adequate ventilation in the DHW pipework.

2. Turn drain valve from lever position (A) (operational) to lever position (B) or (C) as required.
 - Lever position (B): Drain drinking water circuit in appliance **excluding** DHW cylinder via the cold water connection.
 - Lever position (C): Drain drinking water circuit in appliance **and** DHW cylinder via the DHW connection. The cold water connection remains filled.

Further details regarding the individual steps (cont.)

Cleaning the primary store

Note

According to EN 806, a visual inspection and (if necessary) cleaning must be carried out no later than two years after commissioning and thereafter as required.

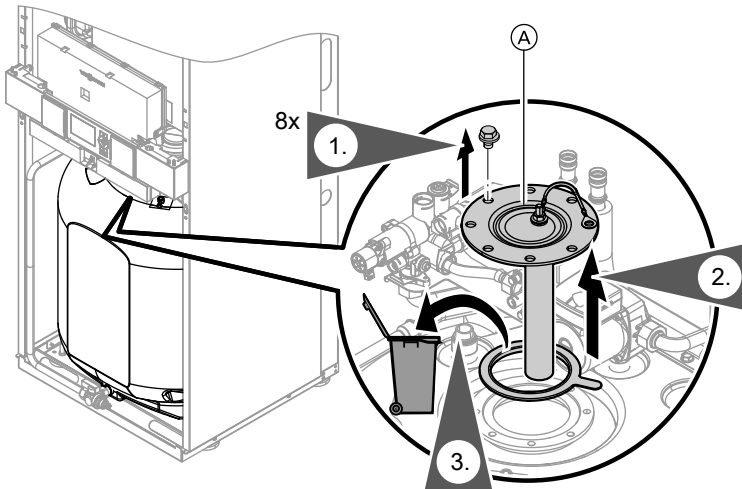

1. Drain the primary store.
2. Remove flange cover (A).
3. Disconnect the primary store from the pipework to prevent contamination from entering the pipe system.
4. Remove loose deposits with a high pressure cleaner.
5. Use a chemical cleaning agent to remove hard deposits that cannot be removed by a high pressure cleaner.
6. Thoroughly flush the primary store after cleaning.



Please note

When cleaning the inside, only use plastic cleaning utensils.



Please note

Never use hydrochloric acid based cleaning agents.

Further details regarding the individual steps (cont.)

Checking and replacing the magnesium anode (if required)

Check the magnesium anode. If it is discovered that the anode has degraded to 10 to 15 mm Ø, we recommend replacing the magnesium anode.

Re-assembling and filling the primary store

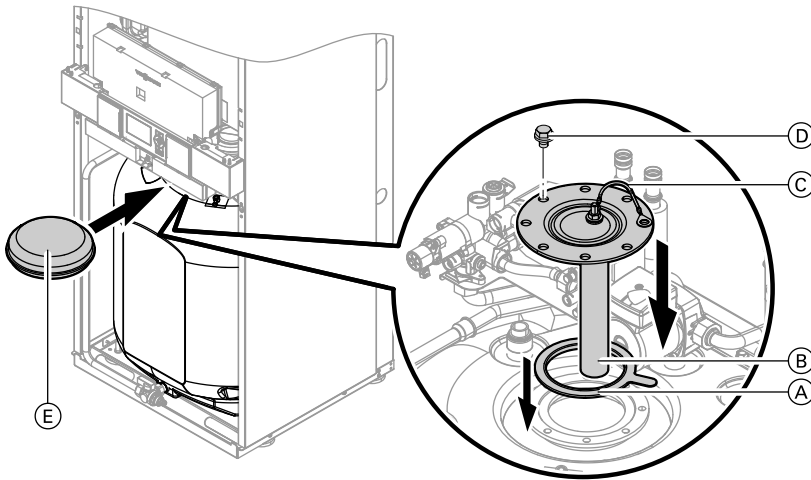

1. Reconnect the primary store to the pipework.
2. Insert new gasket (A) underneath flange cover (B).
3. Fit flange cover (B) and tighten eight screws (D) with a maximum torque of 25 Nm.
4. Push earth cable (C) onto the tab.
5. Fit cover (E).
6. Fill the primary store with drinking water.

Further details regarding the individual steps (cont.)

Checking the expansion vessel and system pressure

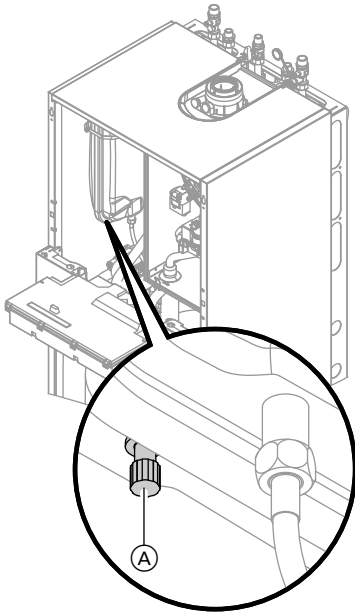

Note

The diaphragm expansion vessel can lose some charge pressure over a time in use. When the boiler heats up, the pressure gauge will indicate a higher pressure of 2 or 3 bar (0.2 or 0.3 MPa). The safety valve too can respond and discharge excess volume (only **GB**).

Check whether the installed diaphragm expansion vessel is adequate for the system water pressure (only **GB**).

Note

Carry out this test on a cold system.

1. Drain the system until the pressure gauge shows "0".
2. If the diaphragm expansion vessel pre-charge pressure is lower than the static system pressure: Top up with nitrogen at connection **A** until the pre-charge pressure is 0.1 to 0.2 bar (10 to 20 kPa) higher than the static system pressure.
3. Top up with water until the charge pressure of the cooled system is 0.1 to 0.2 bar (10 to 20 kPa) higher than the pre-charge pressure of the diaphragm expansion vessel. Permiss. operating pressure: 3 bar (300 kPa).

Further details regarding the individual steps (cont.)

Checking the pre-charge pressure and the DHW expansion vessel (if installed)

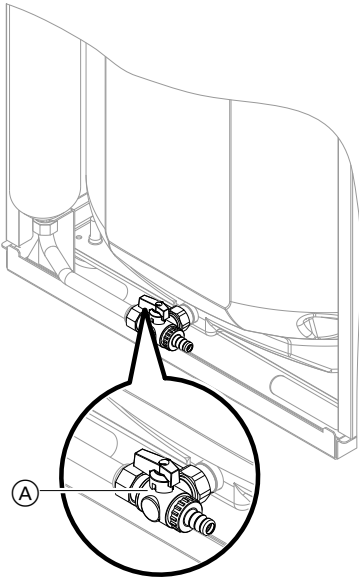

1. Check the static pressure of the DHW line downstream of the pressure reducer and adjust if required. Set value: max. 3.0 bar (0.3 MPa).
2. Close the on-site shut-off valve in the cold water line.
3. Turn operating lever of valve (A) to the "front" position.
4. Check the pre-charge pressure of the DHW expansion vessel and adjust if required. Set value: Static pressure minus 0.2 bar (0.02 MPa).
5. Turn operating lever of valve (A) back to the "left" position and open the on-site shut-off valve in the cold water line.

Checking all gas equipment for tightness at operating pressure



Danger

Escaping gas leads to a risk of explosion.
Check all gas equipment for tightness.

Note

*Only use suitable and approved leak detection agents (EN 14291) and devices for the tightness test. Leak detection agents with unsuitable constituents (e.g. nitrites, sulphides) can cause material damage.
Remove residues of the leak detection agent after testing.*

Further details regarding the individual steps (cont.)

Checking the combustion quality

The electronic combustion controller automatically ensures optimum combustion quality. During commissioning/maintenance, only the combustion values need to be checked. For this, measure the CO content and the CO₂ or O₂ content. For a description of the electronic combustion controller functions, see page 166.

Note

Operate the appliance with uncontaminated combustion air to prevent operating faults and damage.

CO content

- The CO content must be < 1000 ppm for all gas types.

CO₂ or O₂ content

- The CO₂ content must be within the following limits (for upper and lower heating output respectively):
 - 7.5 to 9.5 % for natural gas E and LL
 - 8.8 to 11.1 % for LPG P
- For all gas types, the O₂ content must be between 4.0 and 7.6 %

If the actual CO₂ or O₂ values lie outside their respective ranges, proceed with the following steps:

- Carry out a tightness test of the balanced flue system, see page 49.
- Check the ionisation electrode and connecting cable, see page 52.

Note

During commissioning, the combustion controller carries out an automatic calibration. Only test the emissions approx. 30 s after the burner has started.

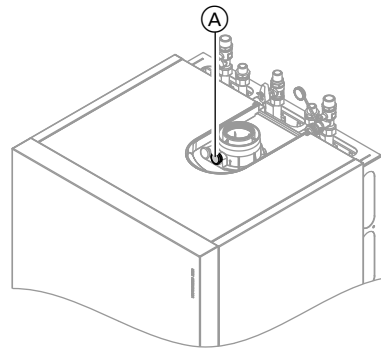

1. Connect a flue gas analyser at flue gas port (A) on the boiler flue connection.
2. Open the gas shut-off valve, start the boiler and create a heat demand.
3. Select the lower heating output (see page 64).
4. Check the CO₂ content. Should the actual value deviate from the aforementioned ranges by more than 1 %, implement steps from page 63.
5. Enter actual values into the report.
6. Select the upper heating output (see page 64).



Further details regarding the individual steps (cont.)

7. Check the CO₂ content. Should the actual value deviate from the aforementioned ranges by more than 1 %, implement steps from page 63.
8. After testing, press **OK**.
9. Enter actual values into the report.

Select higher/lower heating output







Weather-compensated control unit

Service menu

1. Press **OK** and  simultaneously for approx. 4 s.
2. **"Actuator test"**
3. Select the lower heating output:
Select **"Base load OFF"**. Then **"Base load ON"** appears and the burner operates at its lower heating output.
4. Select the upper heating output:
Select **"Full load OFF"**. Then **"Full load ON"** appears and the burner operates at its upper heating output.
5. Ending output selection:
Press .

Constant temperature control unit

Service menu

1. Press **OK** and  simultaneously for approx. 4 s.
2. Select  with  and confirm with **OK**.
The display shows **"I"** and **"ON"** flashes.
3. Select the lower heating output:
Press **OK**, **"ON"** will be displayed constantly.
4. Select the upper heating output:
Press .
5. Select **"2"** with ; **"ON"** flashes.
6. Press **OK**, **"ON"** will be displayed constantly.
7. Ending output selection:
Press .

Matching the control unit to the heating system

The control unit must be adjusted subject to the system equipment level.

- To do this, select the relevant system scheme (see the following diagrams).
- Set the codes in conjunction with the accessories fitted.



Accessories installation and service instructions

Note

Various system components are recognised automatically by the control unit and the relevant codes are adjusted automatically.

For individual steps for coding, see page 77.

Further details regarding the individual steps (cont.)

System version 1

One heating circuit without mixer A1

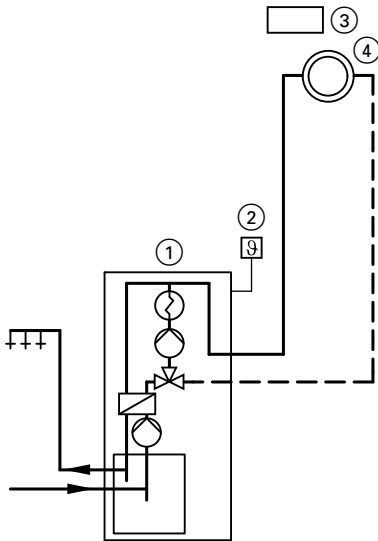

- ① Vitodens 222-F
- ② Outside temperature sensor (only for weather-compensated control units)
- ③ Vitotrol 100 (only for constant temperature control units)
- ④ Heating circuit without mixer A1 (heating circuit 1)

Function/system components	Code	
	Adjust	Group
Operation with LPG	82:1	"General"/1
System with DHW circulation pump: DHW circulation pump connection at internal extension H1 or H2	—	—

Further details regarding the individual steps (cont.)

System version 2

One heating circuit with mixer M2 and a low loss header

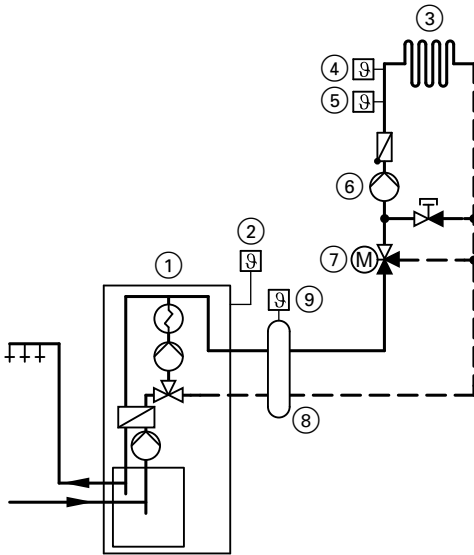

- ① Vitodens 222-F
- ② Outside temperature sensor
- ③ Heating circuit with mixer M2 (heating circuit 2)
- ④ Temperature limiter to restrict the maximum temperature of underfloor heating systems
- ⑤ Flow temperature sensor M2
- ⑥ Heating circuit pump M2
- ⑦ Extension kit for one heating circuit with mixer M2
- ⑧ Low loss header
- ⑨ Flow temperature sensor, low loss header

Function/system components	Code	
	Adjust	Group
Operation with LPG	82:1	"General"
System with only one heating circuit with mixer and DHW heating	00:4	"General"
System with DHW circulation pump: DHW circulation pump connection at internal extension H1 or H2	—	—
System with low loss header	04:0	"Boiler"

Further details regarding the individual steps (cont.)

System version 3

One heating circuit without mixer A1 and one heating circuit with mixer M2

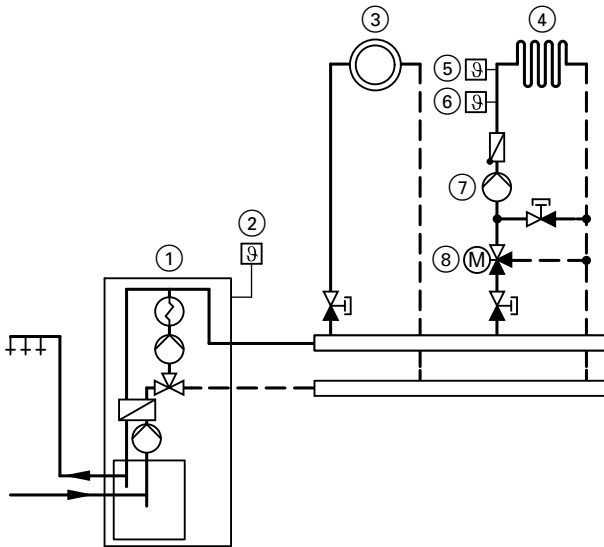

- | | |
|---|---|
| ① Vitodens 222-F | ⑥ Flow temperature sensor M2 |
| ② Outside temperature sensor | ⑦ Heating circuit pump M2 |
| ③ Heating circuit without mixer A1 (heating circuit 1) | ⑧ Extension kit for one heating circuit with mixer M2 |
| ④ Heating circuit with mixer M2 (heating circuit 2) | |
| ⑤ Temperature limiter to restrict the maximum temperature of underfloor heating systems | |

Note

The flow rate of the heating circuit without mixer must be at least 30 % greater than the flow rate of the heating circuit with mixer.

Further details regarding the individual steps (cont.)

Function/system components	Code	
	Adjust	Group
Operation with LPG	82:1	"General"
System only with one heating circuit with mixer with extension kit for mixer (without unregulated heating circuit) with DHW heating	00:4	"General"
System with DHW circulation pump: DHW circulation pump connection at internal extension H1 or H2	—	—

System version 4

One heating circuit without mixer A1, one heating circuit with mixer M2 and system separation

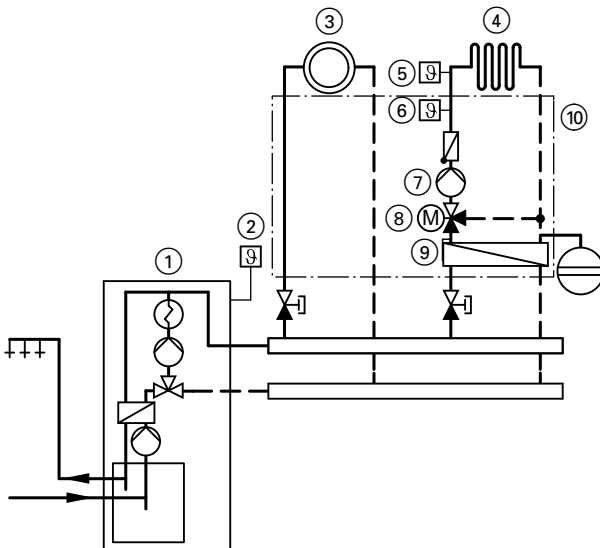

- ① Vitodens 222-F
- ② Outside temperature sensor
- ③ Heating circuit without mixer A1 (heating circuit 1)
- ④ Heating circuit with mixer M2 (heating circuit 2)
- ⑤ Temperature limiter to restrict the maximum temperature of underfloor heating systems
- ⑥ Flow temperature sensor M2
- ⑦ Heating circuit pump M2
- ⑧ Extension kit for one heating circuit with mixer M2

Further details regarding the individual steps (cont.)

- ⑨ Heat exchanger for system separation
- ⑩ Assembly kit with mixer (accessories)

Function/system components	Code	
	Adjust	Group
Operation with LPG	82:1	"General"
System only with one heating circuit with mixer with extension kit for mixer (without unregulated heating circuit) with DHW heating	00:4	"General"
System with DHW circulation pump: DHW circulation pump connection at internal extension H1 or H2	—	—

System version 5

One heating circuit without mixer, one heating circuit with mixer M2 (with extension kit), one heating circuit with mixer M3 (with extension kit) and low loss header (with/without DHW heating)

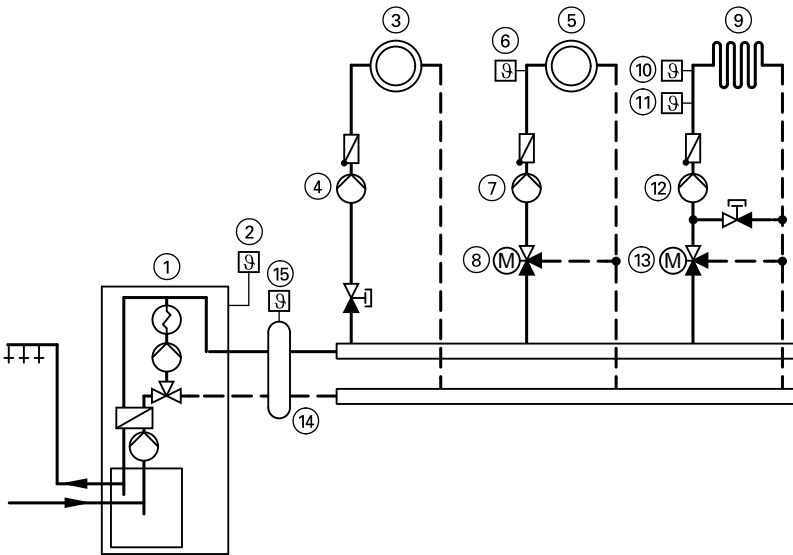

- ① Vitodens 222-F

② Outside temperature sensor
- ③ Heating circuit without mixer A1 (heating circuit 1)

④ Heating circuit pump A1



Further details regarding the individual steps (cont.)

- ⑤ Heating circuit with mixer M2 (heating circuit 2)
- ⑥ Flow temperature sensor M2
- ⑦ Heating circuit pump M2
- ⑧ Extension kit for one heating circuit with mixer M2
- ⑨ Heating circuit with mixer M3 (heating circuit 3)
- ⑩ Temperature limiter to restrict the maximum temperature of underfloor heating systems
- ⑪ Flow temperature sensor M3
- ⑫ Heating circuit pump M3
- ⑬ Extension kit for one heating circuit with mixer M3
- ⑭ Low loss header
- ⑮ Flow temperature sensor, low loss header

Function/system components	Code	
	Adjust	Group
Operation with LPG	82:1	"General"
System only with two heating circuits with mixer with extension kit for mixer (without unregulated heating circuit) with DHW heating	00:8	"General"
System without DHW circulation pump: Heating circuit pump A1 connection at internal extension H1 or H2	53:2	—
System with DHW circulation pump: Heating circuit pump A1 connection at extension AM1, terminal A1	—	—
DHW circulation pump connection at extension AM1, terminal A2	—	—
or DHW circulation pump connection at internal extension H1 or H2	—	—
System with low loss header	04:0	"Boiler"

Adjusting the heating curves (only for weather-compensated control units)

The heating curves illustrate the relationship between the outside temperature and the boiler water or flow temperature.

To put it simply, the lower the outside temperature, the higher the boiler water or flow temperature.

The boiler water or flow temperature in turn affects the room temperature.

Settings in the delivered condition:

- Slope = 1.4
- Level = 0

Further details regarding the individual steps (cont.)

Note

If the heating system includes heating circuits with mixers, then the flow temperature of the heating circuit without mixer is higher by a selected differential (8 K in the delivered condition) than the flow temperature of the heating circuits with mixers.

The differential temperature is adjustable via coding address "9F" in the "General" group.

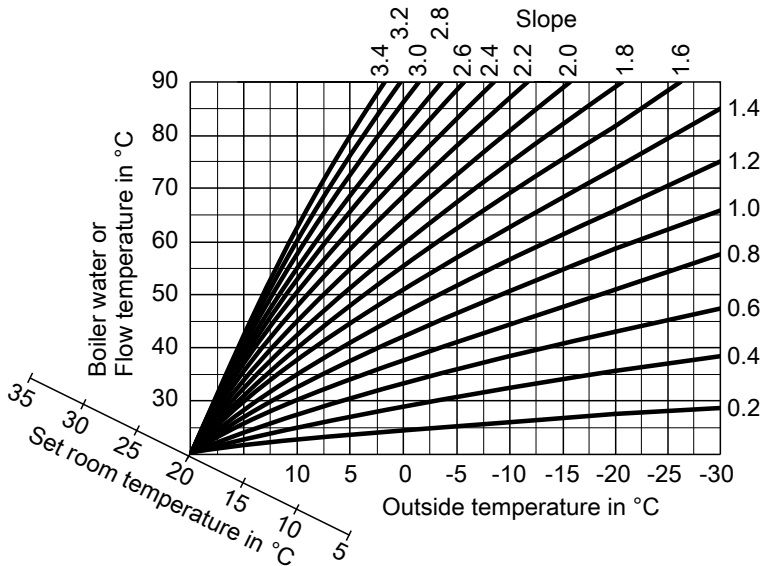

Slope setting ranges:

- Underfloor heating systems: 0.2 to 0.8
- Low temperature heating systems: 0.8 to 1.6

Selecting the set room temperature

Individually adjustable for each heating circuit.

The heating curve is offset along the axis of the set room temperature. With the heating circuit pump logic function enabled, the curve modifies the starting and stopping characteristics of the heating circuit pump.

Further details regarding the individual steps (cont.)

Standard set room temperature

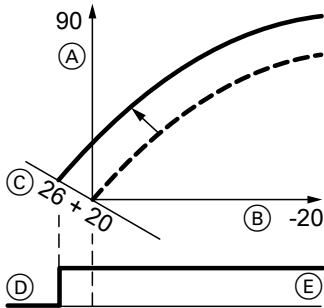

Example 1: Adjustment of the standard set room temperature from 20 to 26 °C

- (A) Boiler water temperature or flow temperature in °C
- (B) Outside temperature in °C
- (C) Set room temperature in °C
- (D) Heating circuit pump "OFF"
- (E) Heating circuit pump "ON"

Changing the standard set room temperature



Operating instructions

Reduced set room temperature

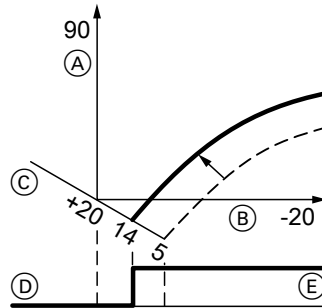

Example 2: Adjustment of the reduced set room temperature from 5 °C to 14 °C

- (A) Boiler water temperature or flow temperature in °C
- (B) Outside temperature in °C
- (C) Set room temperature in °C
- (D) Heating circuit pump "OFF"
- (E) Heating circuit pump "ON"

Changing the reduced set room temperature



Operating instructions

Changing the slope and level

Individually adjustable for each heating circuit.

Further details regarding the individual steps (cont.)

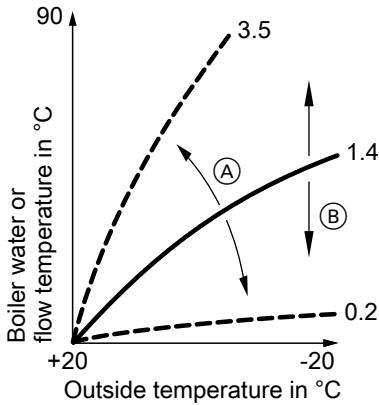

Extended menu:

1. 
2. "Heating"
3. Select heating circuit.
4. "Heating curve"
5. "Slope" or "Level"
6. Select heating curve according to the system requirements.

- (A) Changing the slope
 (B) Changing the level (vertical parallel offset of the heating curve)

Connecting the control unit to the LON

The LON communication module (accessories) must be plugged in.



Installation instructions
 LON communication module

Note

The data transfer via LON can take several minutes.

Single boiler system with Vitotronic 200-H and Vitocom 200 (example)

Set the LON subscriber numbers and further functions via code 2 (see the following table).





Note

In the same LON system, the same subscriber number must **not** be allocated twice.

Only one Vitotronic may be programmed as fault manager.

Further details regarding the individual steps (cont.)

All coding addresses in the table are listed in the "General" group.

Boiler control unit	Vitotronic 200-H	Vitotronic 200-H	Vitocom
			
Subscriber no. 1, Code "77:1".	Subscriber no. 10, Code "77:10".	Subscriber no. 11, Set code "77:11".	Subscriber no. 99.
Control unit is fault manager, Code "79:1".	Control unit is not fault manager, Code "79:0".	Control unit is not fault manager, Code "79:0".	Device is fault manager.
Control unit transmits the time, Code "7b:1".	Control unit receives the time, Set code "81:3".	Control unit receives the time, Set code "81:3".	Device re- ceives the time.
Control unit transmits outside temperature, Set code "97:2".	Control unit receives outside tempera- ture, Set code "97:1".	Control unit receives outside tempera- ture, Set code "97:1".	—
Viessmann system number, Code "98:1".	Viessmann system number, Code "98:1".	Viessmann system number, Code "98:1".	—
LON subscriber fault monitoring, Code "9C:20".	LON subscriber fault monitoring, Code "9C:20".	LON subscriber fault monitoring, Code "9C:20".	—

Carrying out a LON subscriber check

The subscriber check is used to test communication with the system devices connected to the fault manager.

Preconditions:

- The control unit must be programmed as **fault manager** (code "79:1" in the "General" group).
- The LON subscriber number must be programmed in all control units.
- The LON subscriber list in the fault manager must be up to date.

Service menu:

1. Press **OK** and **≡**: simultaneously for approx. 4 s.
2. **"Service functions"**
3. **"Subscriber check"**
4. Select subscriber (e.g. subscriber 10).
5. Start the subscriber check with **"OK"**.

Further details regarding the individual steps (cont.)

- Successfully tested subscribers are designated with **"OK"**.
- Unsuccessfully tested subscribers are designated with **"Not OK"**.

Note

To carry out a new subscriber check, create a new subscriber list with **"Delete list?"** (subscriber list is updated).

Note

During the subscriber check, the display for the relevant subscriber shows the subscriber no. and **"Wink"** for approx. 1 min.

Scanning and resetting the "Service" display



The red fault indicator flashes when the limits set in coding addresses "21" and "23" have been reached. (Coding address in group **"Boiler"** (weather-compensated control unit) or group 2 (constant temperature control unit).)

Weather-compensated control unit

Constant temperature control unit

Display

"Service" and "

The specified hours run or the specified interval with calendar symbol "" (subject to setting) and "

Acknowledging a service

Press **OK**.
Service the appliance.

Press **OK**.
Service the appliance.

Note

An acknowledged service message that was not reset appears again the following Monday.

Note

An acknowledged service message that was not reset appears again after 7 days.



Further details regarding the individual steps (cont.)

Weather-compensated control unit

After the service has been carried out:

Service menu:

1. Press **OK** and  simultaneously for approx. 4 s.
2. **"Service functions"**
3. **"Service reset"**

Note

The selected service parameters for hours run and interval restart at "0".

Constant temperature control unit

Reset the codes

Reset code "24:1" in group 2 to "24:0".

Note

The selected service parameters for hours run and interval restart at "0".

Fitting the cover panel and front panels

- Fit the cover panel; see position (A) in diagram on page 39.
- Fit the front panels; see page 31.

Instructing the system user

The system installer should hand the operating instructions to the system user and instruct the user in operating the system.

This includes all components installed as accessories, e.g. remote control units. In addition, the system installer must make the user aware of the required maintenance work.

Calling up coding level 1

- On weather-compensated control units, codes are displayed as plain text.
- Codes that have not been assigned due to the heating system equipment level or the setting of other codes are not displayed.
- Heating systems with one heating circuit without mixer and one or two heating circuits with mixer:

The heating circuit without mixer is designated "**Heating circuit 1**" and the heating circuits with mixer as "**Heating circuit 2**" or "**Heating circuit 3**".

If the heating circuits were given individual designations, the selected designation and "**HC1**", "**HC2**" or "**HC3**" appear instead.

Weather-compensated control unit

The codes are divided into groups

- **"General"**
- **"Boiler"**
- **"DHW"**
- **"Heating circuit 1/2/3"**
- **"All codes std device"**
In this group, all coding addresses from coding level 1 are displayed in ascending order.
- **"Standard setting"**

Call up code 1

Service menu:

1. Press **OK** and  simultaneously for approx. 4 s.
2. **"Coding level 1"**
3. Select group of required coding address.
4. Select coding address.
5. Select value according to the following tables and confirm with **OK**.









Constant temperature control unit

- 1: **"General"**
- 2: **"Boiler"**
- 3: **"DHW"**
- 5: **"Heating circuit 1"**
- 6: **"All codes std device"**

In this group, all coding addresses are displayed in ascending order.

- 7: **"Standard setting"**

Service menu:

1. Press **OK** and  simultaneously for approx. 4 s.
2. Select "**1**" with  for coding level 1 and confirm with **OK**.
3. "**I**" flashes on the display for the coding addresses in group 1.
4. Select the group of the required coding address with / and confirm with **OK**.
5. Select coding address with /.
6. Set value according to the following tables with / and confirm with **OK**.

Resetting all codes to their delivered condition

Select **"Standard setting"**.

Select **"7"** with  and confirm with **OK**.
When "**I**" flashes, confirm with **OK**.

Note

This also resets codes at coding level 2.

Note

This also resets codes at coding level 2.

"General"/group 1

Select **"General"** for weather-compensated control units (see page 77).

Select **"1"** for constant temperature control units (see page 77).

Coding

Coding in the delivered condition		Possible change	
System design			
00:2	One heating circuit without mixer A1 (heating circuit 1)	00:4 to 00:10	For system schemes, see the following table:

Value address 00: ...	Description
2	One heating circuit without mixer A1 (heating circuit 1) (code is set automatically)
4	One heating circuit with mixer M2 (heating circuit 2)
6	One heating circuit without mixer A1 (heating circuit 1) One heating circuit with mixer M2 (heating circuit 2) (code is set automatically)
8	One heating circuit with mixer M2 (heating circuit 2) One heating circuit with mixer M3 (heating circuit 3)
10	One heating circuit without mixer A1 (heating circuit 1) Two heating circuits with mixer M2 (heating circuit 2) and M3 (heating circuit 3) (code is set automatically)

"General"/group 1 (cont.)

Coding in the delivered condition		Possible change	
Internal circulation pump function			
51:0	Internal circulation pump always starts when there is a heat demand	51:1	System with low loss head-er: When there is a heat de-mand, the internal circula-tion pump is only started if the burner is operational. Circulation pump is switch-ed off on expiry of run-on time
		51:2	System with heating water buffer cylinder: When there is a heat de-mand, the internal circula-tion pump is only started if the burner is operational. Circulation pump is switch-ed off on expiry of run-on time
Subscriber no.			
77:1	LON subscriber number (only for weather-com-pensated control units)	77:2 to 77:99	LON subscriber number, adjustable from 1 to 99: 1 - 4 = Boiler 5 = Cascade 10 - 97 = Vitotronic 200-H 98 = Vitogate 99 = Vitocom
Detached house/apartment building			
7F:1	Detached house (only for weather-compensated control units)	7F:0	Apartment building Separate adjustment of holiday program and time program for DHW heating possible

"General"/group 1 (cont.)

Coding in the delivered condition		Possible change	
Lock out controls			
8F:0	Operation in the standard menu and extended menu enabled Note <i>The respective code is only activated when you exit the service menu (see page 111).</i>	8F:1	Operation in standard menu and extended menu blocked. Emissions test mode can be enabled
		8F:2	Operation enabled in the standard menu and blocked in the extended menu. Emissions test mode can be enabled
Set flow temperature for external demand			
9b:70	Set flow temperature for external demand 70 °C	9b:0 to 9b:127	Set value adjustable from 0 to 127 °C (limited by boiler-specific parameters)

"Boiler"/group 2

Select **"Boiler"** for weather-compensated control units (see page 77).

Select **"2"** for constant temperature control units (see page 77).

Coding

Coding in the delivered condition		Possible change	
Single/multi-boiler system			
01:1	Do not adjust (only for constant temperature control units)		
Burner service in 100 hours			
21:0	No service interval (hours run) selected	21:1 to 21:100	The number of hours run before the burner should be serviced is adjustable from 100 to 10 000 h. One adjusting step \triangleq 100 h

"Boiler"/group 2 (cont.)

Coding in the delivered condition		Possible change	
Service interval in months			
23:0	No interval for burner service	23:1 to 23:24	Interval adjustable from 1 to 24 months
Service status			
24:0	"Service" not shown on display	24:1	"Service" is shown on display (the address is automatically set and must be manually reset after a service has been carried out)
Filling/Venting			
2F:0	Venting program/fill program disabled	2F:1	Venting program enabled
		2F:2	Fill program enabled

"DHW"/group 3

Select **"DHW"** for weather-compensated control units (see page 77).

Select **"3"** for constant temperature control units (see page 77).

Coding

Coding in the delivered condition		Possible change	
Enable DHW circulation pump			
73:0	DHW circulation pump: "ON" in accordance with the time program (only for weather-compensated control units)	73:1 to 73:6	During time program "ON" from once per hour for 5 min to "ON" 6 times per hour for 5 min
		73:7	Constantly "ON"

"Heating circuit ..."/group 5

Select **"Heating circuit ..."** for weather-compensated control units (see page 77).

Select **"5"** for constant temperature control units (see page 77).

"Heating circuit ..."/group 5 (cont.)**Coding**

Coding in the delivered condition		Possible change	
Economy function outside temperature			
A5:5	With heating circuit pump logic function (economy control): heating circuit pump "OFF" when the outside temperature (AT) is 1 K higher than the set room temperature (RT_{set}) $AT > RT_{set} + 1$ K (only for weather-compensated control units)	A5:0	Without heating circuit pump logic function
		A5:1 to A5:15	With heating circuit pump logic function: Heating circuit pump "OFF"; see following table

Parameter address A5:...	With heating circuit pump logic function: Heating circuit pump "OFF"
1	$AT > RT_{set} + 5$ K
2	$AT > RT_{set} + 4$ K
3	$AT > RT_{set} + 3$ K
4	$AT > RT_{set} + 2$ K
5	$AT > RT_{set} + 1$ K
6	$AT > RT_{set}$
7	$AT > RT_{set} - 1$ K
to 15	$AT > RT_{set} - 9$ K

"Heating circuit ..."/group 5 (cont.)

Coding in the delivered condition		Possible change	
Extended economy function adjusted outside temperature			
A6:36	Extended economy control disabled (only for weather-compensated control units)	A6:5 to A6:35	Extended economy control enabled, i.e. the burner and heating circuit pump will stop and the mixer will be closed at a variable value, adjustable between 5 and 35 °C plus 1 °C. The base value is the adjusted outside temperature. This value is based on the actual outside temperature and a time constant, which takes the cooling down of an average building into consideration
Extended economy function mixer			
A7:0	Only for heating circuit with mixer: Without mixer economy function (only for weather-compensated control units)	A7:1	With mixer economy function (extended heating circuit pump logic): Heating circuit pump also "OFF": <ul style="list-style-type: none"> ■ If the mixer has been closed for longer than 20 min. Heating circuit pump "ON": <ul style="list-style-type: none"> ■ If the mixer changes to control function ■ If there is a risk of frost
Pump idle time, transition reduced mode			
A9:7	With pump idle time: Heating circuit pump "OFF" if the set value is altered through a change in operating mode or through a change in the set room temperature (only for weather-compensated control units)	A9:0	Without pump idle time
		A9:1 to A9:15	With pump idle time, adjustable from 1 to 15. 1 = short idle period 15 = long idle time



"Heating circuit ..."/group 5 (cont.)

Coding in the delivered condition		Possible change	
Weather-compensated/room temperature hook-up			
b0:0	Only for heating circuit with mixer and remote control: Heating mode/reduced mode: Weather-compensated (only for weather-compensated control units)	b0:1	Heating mode: weather-compensated. Reduced mode: With room temperature hook-up
		b0:2	Heating mode: With room temperature hook-up Reduced mode: Weather-compensated
		b0:3	Heating mode/reduced mode: With room temperature hook-up

Economy function room temperature

b5:0	Only for heating circuit with mixer and remote control: No room temperature-dependent heating circuit pump logic function (only for weather-compensated control units)	b5:1 to b5:8	Heating circuit pump logic function, see the following table
------	---	--------------	--

Parameter address b5:...	With heating circuit pump logic function:	
	Heating circuit pump "OFF"	Heating circuit pump "ON"
1	$RT_{actual} > RT_{set} + 5 K$	$RT_{actual} < RT_{set} + 4 K$
2	$RT_{actual} > RT_{set} + 4 K$	$RT_{actual} < RT_{set} + 3 K$
3	$RT_{actual} > RT_{set} + 3 K$	$RT_{actual} < RT_{set} + 2 K$
4	$RT_{actual} > RT_{set} + 2 K$	$RT_{actual} < RT_{set} + 1 K$
5	$RT_{actual} > RT_{set} + 1 K$	$RT_{actual} < RT_{set}$
6	$RT_{actual} > RT_{set}$	$RT_{actual} < RT_{set} - 1 K$
7	$RT_{actual} > RT_{set} - 1 K$	$RT_{actual} < RT_{set} - 2 K$
8	$RT_{actual} > RT_{set} - 2 K$	$RT_{actual} < RT_{set} - 3 K$

"Heating circuit ..."/group 5 (cont.)

Coding in the delivered condition		Possible change	
Min. flow temperature heating circuit			
C5:20	Electronic minimum flow temperature limit 20 °C (only in operation with standard room temperature; only for weather-compensated control units)	C5:1 to C5:127	Minimum limit adjustable from 1 to 127 °C (limited by boiler-specific parameters)
Max. flow temperature heating circuit			
C6:74	Electronic maximum flow temperature limit 74 °C (only for weather-compensated control units)	C6:10 to C6:127	Maximum limit adjustable from 10 to 127 °C (limited by boiler-specific parameters)
Heating program - changeover			
d5:0	With external heating program changeover (observe setting for coding addresses "3A", "3b" and "3C" in group " General "). Heating program switches to "Constant central heating with reduced room temperature" or "Standby mode" (subject to the settings of the set reduced room temperature) (only for weather-compensated control units).	d5:1	The heating program changes to "Constant operation with standard room temperature".
Ext. heating program changeover to heating circuit			
d8:0	With extension EA1: No heating program changeover.	d8:1	Heating program changeover via input DE1.
		d8:2	Heating program changeover via input DE2.
		d8:3	Heating program changeover via input DE3.

"Heating circuit ..."/group 5 (cont.)

Coding in the delivered condition		Possible change	
Max. pump speed in standard mode			
E6:...	Only for heating systems without a heating circuit with mixer: Maximum speed of the internal variable speed heating circuit pump in % of the max. speed in standard mode. Value is specified by boiler-specific parameters (only for weather-compensated control units)	E6:0 to E6:100	Maximum speed adjustable from 0 to 100 %
Min. pump speed			
E7:30	Only for heating systems without a heating circuit with mixer: Minimum speed of the internal variable speed heating circuit pump: 30 % of the max. speed (only for weather-compensated control units)	E7:0 to E7:100	Minimum speed adjustable from 0 to 100 % of the maximum speed
Screed function			
F1:0	Screed drying disabled (only for weather-compensated control units)	F1:1 to F1:6	Only for heating circuit with mixer: Screed drying adjustable in accordance with 6 selectable temperature/time profiles (see page 161)
		F1:15	Constant flow temperature 20 °C

"Heating circuit ..."/group 5 (cont.)

Coding in the delivered condition		Possible change	
Party mode time limit			
F2:8	Time limit for party mode or external heating program changeover via pushbutton: 8 h (only for weather-compensated control units) ^{*1}	F2:0	No time limit.* ¹
		F2:1 to F2:12	Time limit adjustable from 1 to 12 h ^{*1}
<p>Note Observe settings of coding addresses "3A", "3b" and "3C" in group "General", as well as "d5" and "d8" in group "Heating circuit...".</p>			
Pump control in "Only DHW"			
F6:25	In the "Only DHW" operating mode, the internal circulation pump is permanently on (only for constant temperature control units)	F6:0	In the "Only DHW" operating mode, the internal circulation pump is permanently off
		F6:1 to F6:24	In operating mode "Only DHW", the internal circulation pump will be started 1 to 24 times per day for 10 minutes each time.
Pump control in "Standby mode"			
F7:25	In "Standby mode", the internal circulation pump is permanently on (only for constant temperature control units)	F7:0	In "Standby mode", the internal circulation pump is permanently off
		F7:1 to F7:24	In "Standby mode", the internal circulation pump will be started 1 to 24 times per day for 10 min each time

*1 In the "Heating and DHW" program, party mode ends **automatically** when the system changes over to operation with standard room temperature.



"Heating circuit ..."/group 5 (cont.)

Coding in the delivered condition		Possible change	
Start temperature raising			
F8:-5	Temperature limit for terminating reduced mode -5 °C, see example on page 163. Observe the setting of coding address "A3". (only for weather-compensated control units)	F8:+10 to F8:-60	Temperature limit adjustable from +10 to -60 °C
		F8:-61	Function disabled
End temperature raising			
F9:-14	Temperature limit for raising the reduced set room temperature -14 °C; see example on page 163 (only for weather-compensated control units)	F9:+10 to F9:-60	Temperature limit for raising the set room temperature to the value selected for standard mode adjustable from +10 to -60 °C
Set flow temperature increase			
FA:20	Raising the set boiler water or flow temperature by 20 % when changing from operation with reduced room temperature to operation with standard room temperature. See example on page 164 (only for weather-compensated control units)	FA:0 to FA:50	Temperature rise adjustable from 0 to 50 %
Duration set flow temperature increase			
Fb:60	Duration of the set boiler water or flow temperature rise (see coding address "FA") 60 min. See example on page 164 (only for weather-compensated control units)	Fb:0 to Fb:300	Duration adjustable from 0 to 300 min

Calling up coding level 2

- All codes are accessible in coding level 2.
- Codes that have not been assigned due to the heating system equipment level or the setting of other codes are not displayed.
- The heating circuit without mixer is designated "**Heating circuit 1**" and the heating circuits with mixer as "**Heating circuit 2**" or "**Heating circuit 3**".

If the heating circuits were given individual designations, the selected designation and "**HC1**", "**HC2**" or "**HC3**" appear instead.

Weather-compensated control unit

The codes are divided into groups



- "General"
- "Boiler"
- "DHW"
- "Heating circuit 1/2/3"
- "All codes std device"
In this group, all coding addresses are displayed in ascending order.
- "Standard setting"

Constant temperature control unit









- 1: "General"
- 2: "Boiler"
- 3: "DHW"
- 4: "Solar"
- 5: "Heating circuit 1"
- 6: "All codes std device"
In this group, all coding addresses are displayed in ascending order.
- 7: "Standard setting"

Call up code 2

Service menu:

1. Press **OK** and  simultaneously for approx. 4 s.
2. Press **OK** and  simultaneously for approx. 4 s.
3. "**Coding level 2**"
4. Select group of required coding address.
5. Select coding address.
6. Select value according to the following tables and confirm with **OK**.

Service menu:

1. Press **OK** and  simultaneously for approx. 4 s.
2. Press **OK** and  simultaneously for approx. 4 s.
3. Select "**②**" with  for coding level 2 and confirm with **OK**.
4. "**I**" flashes on the display for the coding addresses in group 1.
5. Select the group of the required coding address with / and confirm with **OK**.
6. Select coding address with /.
7. Set value according to the following tables with / and confirm with **OK**.

Calling up coding level 2 (cont.)

Weather-compensated control unit

Resetting all codes to their delivered condition

Select **"Standard setting"**.

Note

This also resets codes at coding level 1.

Constant temperature control unit

Select **"7"** with **▶** and confirm with **OK**.
When **"H"** flashes, confirm with **OK**.

Note

This also resets codes at coding level 1.

"General"/group 1

Select **"General"** for weather-compensated control units (see page 89).

Select **"1"** for constant temperature control units (see page 89).

Coding

Coding in the delivered condition		Possible change	
00:2	One heating circuit without mixer A1 (heating circuit 1)	00:4 to 00:10	For system schemes, see the following table:

Value address 00: ...	Description
2	One heating circuit without mixer A1 (heating circuit 1) (code is set automatically)
4	One heating circuit with mixer M2 (heating circuit 2)
6	One heating circuit without mixer A1 (heating circuit 1) One heating circuit with mixer M2 (heating circuit 2) (code is set automatically)
8	One heating circuit with mixer M2 (heating circuit 2) One heating circuit with mixer M3 (heating circuit 3)
10	One heating circuit without mixer A1 (heating circuit 1) Two heating circuits with mixer M2 (heating circuit 2) and M3 (heating circuit 3) (code is set automatically)

"General"/group 1 (cont.)

Coding in the delivered condition		Possible change	
11:#9	No access to the coding addresses for the combustion controller parameters	11:9	Access open to the coding addresses for the combustion controller parameters
25:0	Without outside temperature sensor (for constant temperature control units)	25:1	With outside temperature sensor (automatic recognition)
2A:0	Without wireless outside temperature sensor	2A:1	With wireless outside temperature sensor (automatic recognition)
		2A:2	Wireless outside temperature sensor not used
2d:0	Do not adjust		
32:0	Without extension AM1	32:1	With extension AM1 (automatic recognition)
33:1	Function output A1 at extension AM1: Heating circuit pump	33:0	DHW circulation pump
		33:2	Circulation pump for cylinder heating
34:0	Function output A2 at extension AM1: DHW circulation pump	34:1	Heating circuit pump
		34:2	Circulation pump for cylinder heating
35:0	Without extension EA1	35:1	With extension EA1 (automatic recognition)
36:0	Function output 157 at extension EA1: Fault message	36:1	Feed pump
		36:2	DHW circulation pump
3A:0	Function input DE1 at extension EA1: No function	3A:1	Heating program - change-over
		3A:2	External demand with set flow temperature. Set value setting: Coding address "9b" in this group. Internal circulation pump function: Coding address "3F" in this group.
		3A:3	External blocking. Internal circulation pump function: Coding address "3E" in this group.

"General"/group 1 (cont.)

Coding in the delivered condition		Possible change	
		3A:4	External blocking with fault message input. Internal circulation pump function: Coding address "3E" in this group.
		3A:5	Fault message input
		3A:6	Brief operation, DHW circulation pump (pushbutton function). DHW circulation pump runtime adjustment: Coding address "3d" in this group.
3b:0	Function input DE2 at extension EA1: No function	3b:1	Heating program - change-over
		3b:2	External demand with set flow temperature. Set value setting: Coding address "9b" in this group. Internal circulation pump function: Coding address "3F" in this group.
		3b:3	Function input DE2: External blocking. Internal circulation pump function: Coding address "3E" in this group.
		3b:4	Function input DE2: External blocking with fault message input Internal circulation pump function: Coding address 3E
		3b:5	Function input DE2: Fault message input
		3b:6	Function input DE2: Brief operation, DHW circulation pump (pushbutton function). DHW circulation pump runtime adjustment: Coding address 3d

"General"/group 1 (cont.)

Coding in the delivered condition		Possible change	
3C:0	Function input DE3 at extension EA1: No function	3C:1	Heating program - change-over
		3C:2	External demand with set flow temperature. Set value setting: Coding address "9b" in this group. Internal circulation pump function: Coding address "3F" in this group.
		3C:3	External blocking. Internal circulation pump function: Coding address "3E" in this group.
		3C:4	External blocking with fault message input Internal circulation pump function: Coding address "3E" in this group.
		3C:5	Fault message input
		3C:6	Brief operation, DHW circulation pump (pushbutton function). DHW circulation pump runtime adjustment: Coding address "3d" in this group
3d:5	DHW circulation pump runtime for brief operation: 5 min	3d:1 to 3d:60	DHW circulation pump runtime adjustable from 1 to 60 min
3E:0	Internal circulation pump stays in control mode at signal "External blocking"	3E:1	Internal circulation pump stops at signal "External blocking"
		3E:2	Internal circulation pump starts at signal "External blocking"
3F:0	Internal circulation pump stays in control mode at signal "External demand"	3F:1	Internal circulation pump stops at signal "External demand"
		3F:2	Internal circulation pump starts at signal "External demand"



"General"/group 1 (cont.)

Coding in the delivered condition		Possible change	
51:0	Internal circulation pump always starts when there is a heat demand	51:1	System with low loss header: When there is a heat demand, the internal circulation pump is only started if the burner is operational. Circulation pump is switched off on expiry of run-on time
		51:2	System with heating water buffer cylinder: When there is a heat demand, the internal circulation pump is only started if the burner is operational. Circulation pump is switched off on expiry of run-on time
52:0	Without flow temperature sensor for low loss header	52:1	With flow temperature sensor for low loss header (automatic recognition)
53:1	Function connection 28 of the internal extension: DHW circulation pump	53:0	Central fault message
		53:2	External heating circuit pump (heating circuit 1)
		53:3	External circulation pump for cylinder heating
54:0	Do not adjust		
6E:50	No display correction of the outside temperature.	6E:0 to 6E:49	Display correction -5 K to Display correction -0.1 K
		6E:51 to 6E:99	Display correction +0.1 K to Display correction +4.9 K
76:0	Without LON communication module (only for weather-compensated control units)	76:1	With LON communication module (automatic recognition)
77:1	LON subscriber number (only for weather-compensated control units)	77:2 to 77:99	LON subscriber number, adjustable from 1 to 99: 1 - 4 = Boiler 5 = Cascade

"General"/group 1 (cont.)

Coding in the delivered condition		Possible change	
			10 - 97 = Vitotronic 200-H 98 = Vitogate 99 = Vitocom
79:1	With LON communication module: Control unit is fault manager (only for weather-compensated control units)	79:0	Control unit is not fault manager
7b:1	With LON communication module: Control unit transmits the time (only for weather-compensated control units)	7b:0	Does not transmit time
7F:1	Detached house (only for weather-compensated control units)	7F:0	Apartment building Separate adjustment of holiday program and time program for DHW heating possible
80:6	A fault message is displayed if a fault is active for at least 30s	80:0	Immediate fault message
		80:2	The minimum fault duration until a fault message is issued is adjustable from 10 to 995 s. 1 step \approx 5 s
		80:199	
81:1	Automatic summer/winter-time changeover	81:0	Manual summer/winter-time changeover
		81:2	Use of the radio clock receiver (automatic recognition)
		81:3	With LON communication module: The control unit receives the time
82:0	Operation with natural gas	82:1	Operation with LPG (only adjustable if coding address "11:9" has been set)
86:...	Do not adjust		
87:...	Do not adjust		

"General"/group 1 (cont.)

Coding in the delivered condition		Possible change	
88:0	Temperature displayed in °C (Celsius)	88:1	Temperature displayed in °F (Fahrenheit)
8A:175	Do not adjust		
8F:0	Operation in the standard menu and extended menu enabled. Note <i>The respective code is only activated when you exit the service menu (see page 111).</i>	8F:1	Operation in standard menu and extended menu blocked. Emissions test mode can be enabled.
		8F:2	Operation enabled in the standard menu and blocked in the extended menu. Emissions test mode can be enabled.
90:128	Time constant for calculating adjusted outside temperature 21.3 h	90:1 to 90:199	Fast (low values) or slow (high values) matching of the flow temperature, subject to the set value when the outside temperature changes. 1 step \triangleq 10 min
94:0	Without OpenTherm extension	94:1	With OpenTherm extension (automatic recognition)
95:0	Without Vitocom 100, type GSM communication interface	95:1	With Vitocom 100 communication interface (automatic recognition)
97:0	With LON communication module: The outside temperature of the sensor connected to the control unit is utilised internally (only for weather-compensated control units)	97:1	Control unit receives outside temperature
		97:2	The control unit transmits the outside temperature to the Vitotronic 200-H
98:1	With LON communication module: Viessmann system number (in conjunction with monitoring several systems via Vitocom 300)	98:1 to 98:5	System number adjustable from 1 to 5

"General"/group 1 (cont.)

Coding in the delivered condition		Possible change	
99:0	Do not adjust		
9A:0	Do not adjust		
9b:70	Set flow temperature for external demand 70 °C	9b:0 to 9b:127	Set value adjustable from 0 to 127 °C (limited by boiler-specific parameters)
9C:20	With LON communication module: Monitoring LON subscribers If there is no response from a subscriber after 20 min, the values specified inside the control unit are used. Only then will a fault message be issued (only for weather-compensated control units)	9C:0	No monitoring
		9C:5 to 9C:60	Time adjustable from 5 to 60 min
9F:8	Only for heating circuit with mixer: Differential temperature 8 K (only for weather-compensated control units)	9F:0 to 9F:40	Differential temperature adjustable from 0 to 40 K

"Boiler"/group 2

Select **"Boiler"** for weather-compensated control units (see page 89).

Select **"2"** for constant temperature control units (see page 89).

Coding

Coding in the delivered condition		Possible change	
04:1	Minimum burner pause time subject to the boiler load (specified by boiler coding card)	04:0	Systems with low loss header:



"Boiler"/group 2 (cont.)

Coding in the delivered condition		Possible change	
			Pause time set permanently (specified by boiler coding card)
06:...	Maximum limit of the boiler water temperature, defaulted in °C by the boiler coding card	06:20 to 06:127	Maximum limit adjustable within the ranges specified by the boiler
0d:0	Do not adjust		
0E:0	Do not adjust		
13:1	Do not adjust		
14:1	Do not adjust		
15:1	Do not adjust		
21:0	No service interval (hours run) selected.	21:1 to 21:100	The number of hours run before the burner should be serviced is adjustable from 100 to 10 000 h. One adjusting step $\hat{=}$ 100 h
23:0	No interval for burner service	23:1 to 23:24	Interval adjustable from 1 to 24 months
24:0	"Service" not shown on display	24:1	"Service" is shown on display (the address is automatically set and must be manually reset after a service has been carried out)
28:0	No burner interval ignition	28:1 to 28:24	Time interval adjustable from 1 h to 24 h. The burner is force-started for 30 s at a time (only when operating with LPG).
2E:0	Do not adjust		
2F:0	Venting program/fill program disabled	2F:1	Venting program enabled
		2F:2	Fill program enabled
30:1	Internal variable speed circulation pump (automatic adjustment)	30:0	Internal circulation pump without variable speed (e.g. temporarily for service)

"Boiler"/group 2 (cont.)

Coding in the delivered condition		Possible change	
31:...	Set speed in % of the internal circulation pump when operated as boiler circuit pump, specified by the boiler coding card	31:0 to 31:100	Set speed adjustable from 0 to 100 %
38:0	Status burner control unit: Operational (no fault)	38:≠0	Status burner control unit: Error

"DHW"/group 3

Select **"DHW"** for weather-compensated control units (see page 89).

Select **"3"** for constant temperature control units (see page 89).

Coding

Coding in the delivered condition		Possible change	
56:0	Set DHW temperature adjustable from 10 to 60 °C	56:1	Set DHW temperature adjustable from 10 to above 60 °C Note <i>Max. value subject to boiler coding card. Observe the max. permissible DHW temperature.</i>
57:0	Do not adjust		
58:0	Without auxiliary function for DHW heating	58:10 to 58:60	Input of a second set DHW temperature, adjustable from 10 to 60 °C (observe coding addresses "56" and "63" in this group)
59:0	Cylinder heating: Start point -2.5 K Stop point +2.5 K	59:1 to 59:10	Start point adjustable from 1 to 10 K below set value
5E:0	Do not adjust		
5F:0	Do not adjust		

"DHW"/group 3 (cont.)

Coding in the delivered condition		Possible change	
60:20	During DHW heating, the boiler water temperature is max. 20 K higher than the set DHW temperature	60:5 to 60:25	The difference between the boiler water temperature and the set DHW temperature is adjustable from 5 to 25 K
62:2	Circulation pump with 2 min run-on time after cylinder heating	62:0	Circulation pump without run-on time
		62:1 to 62:15	Run-on time adjustable from 1 to 15 min
63:0	Without auxiliary function for DHW heating (only for constant temperature control units)	63:1	Auxiliary function: 1 x daily
		63:2 to 63:14	Every 2 days to every 14 days
		63:15	2 x daily
65:...	Do not adjust (Information on the type of diverter valve, specified by the boiler coding card)		
6C:100	Set speed, internal circulation pump for DHW heating 100 %	6C:0 to 6C:100	Set speed adjustable from 0 to 100 %
6F:...	Max. heating output for DHW heating in %, specified by the boiler coding card	6F:0 to 6F:100	Max. heating output for DHW heating adjustable from min. heating output to 100 %
71:0	DHW circulation pump: "ON" in accordance with the time program (only for weather-compensated control units)	71:1	"OFF" during DHW heating to set value 1
		71:2	"ON" during DHW heating to set value 1
72:0	DHW circulation pump: "ON" in accordance with the time program (only for weather-compensated control units)	72:1	"OFF" during DHW heating to set value 2
		72:2	"ON" during DHW heating to set value 2
73:0	DHW circulation pump: "ON" in accordance with the time program (only for weather-compensated control units)	73:1 to	During time program "ON" from once per hour for 5 min to

"DHW"/group 3 (cont.)

Coding in the delivered condition		Possible change	
		73:6	"ON" 6 times per hour for 5 min
		73:7	Constantly "ON"

"Heating circuit ..."/group 5

Select **"Heating circuit ..."** for weather-compensated control units (see page 89).

Select **"5"** for constant temperature control units (see page 89).

Coding

Coding in the delivered condition		Possible change	
A0:0	Without remote control	A0:1	With Vitotrol 200A/200 RF (automatic recognition)
		A0:2	With Vitotrol 300A/300 RF or Vitocomfort (automatic recognition)
A1:0	All possible settings at the remote control can be accessed	A1:1	Only party mode can be set at the remote control (only for Vitotrol 200)
A3:2	Outside temperature below 1 °C: Heating circuit pump "ON" Outside temperature above 3 °C: Heating circuit pump "OFF"	A3:-9 to A3:15	Heating circuit pump "ON/OFF" (see the following table)

**Please note**

If a value below 1 °C is selected, there is a risk that pipes outside the thermal envelope of the house could freeze up.

Standby mode in particular should be taken into consideration, e.g. during holidays.

Parameter Address A3:...	Heating circ pump	
	"ON"	"OFF"
-9	-10 °C	-8 °C
-8	-9 °C	-7 °C
-7	-8 °C	-6 °C

"Heating circuit ..."/group 5 (cont.)

Parameter Address A3:...	Heating circ pump	
	"ON"	"OFF"
-6	-7 °C	-5 °C
-5	-6 °C	-4 °C
-4	-5 °C	-3 °C
-3	-4 °C	-2 °C
-2	-3 °C	-1 °C
-1	-2 °C	0 °C
0	-1 °C	+1 °C
1	0 °C	+2 °C
2	+1 °C	+3 °C
to	to	to
15	+14 °C	+16 °C

Coding in the delivered condition		Possible change	
A4:0	With frost protection (only for weather-compensated control units)	A4:1	No frost protection; this setting is only possible if code "A3:-9" has been selected. ! Please note "Important" to observe for coding address "A3".
A5:5	With heating circuit pump logic function (economy control): heating circuit pump "OFF" when the outside temperature (AT) is 1 K higher than the set room temperature (RT_{set}) $AT > RT_{set} + 1$ K (only for weather-compensated control units)	A5:0 A5:1 to A5:15	Without heating circuit pump logic function With heating circuit pump logic function: Heating circuit pump "OFF"; see following table

Parameter address A5:...	With heating circuit pump logic function: Heating circuit pump "OFF"
1	$AT > RT_{set} + 5$ K
2	$AT > RT_{set} + 4$ K

"Heating circuit ..."/group 5 (cont.)

Parameter address A5:...	With heating circuit pump logic function: Heating circuit pump "OFF"
3	$AT > RT_{\text{set}} + 3 \text{ K}$
4	$AT > RT_{\text{set}} + 2 \text{ K}$
5	$AT > RT_{\text{set}} + 1 \text{ K}$
6	$AT > RT_{\text{set}}$
7	$AT > RT_{\text{set}} - 1 \text{ K}$
to	
15	$AT > RT_{\text{set}} - 9 \text{ K}$

Coding in the delivered condition		Possible change	
A6:36	Extended economy control disabled (only for weather-compensated control units)	A6:5 to A6:35	Extended economy control enabled, i.e. the burner and heating circuit pump will stop and the mixer will be closed at a variable value, adjustable between 5 and 35 °C plus 1 °C. The base value is the adjusted outside temperature. This value is based on the actual outside temperature and a time constant, which takes the cooling down of an average building into consideration
A7:0	Only for heating circuit with mixer: Without mixer economy function (only for weather-compensated control units)	A7:1	With mixer economy function (extended heating circuit pump logic): Heating circuit pump also "OFF": <ul style="list-style-type: none"> ■ If the mixer has been closed for longer than 20 min. Heating circuit pump "ON": <ul style="list-style-type: none"> ■ If the mixer changes to control function ■ If there is a risk of frost



"Heating circuit ..."/group 5 (cont.)

Coding in the delivered condition		Possible change	
A8:1	Heating circuit with mixer creates a demand for the internal circulation pump (only for weather-compensated control units)	A8:0	Heating circuit with mixer creates no demand for the internal circulation pump
A9:7	With pump idle time: Heating circuit pump "OFF" if the set value is altered through a change in operating mode or through a change in the set room temperature (only for weather-compensated control units)	A9:0	Without pump idle time
		A9:1 A9:15	With pump idle time, adjustable from 1 to 15. 1 = short idle period 15 = long idle time
b0:0	Only for heating circuit with mixer and remote control: Heating mode/reduced mode: Weather-compensated (only for weather-compensated control units)	b0:1	Heating mode: weather-compensated. Reduced mode: With room temperature hook-up
		b0:2	Heating mode: With room temperature hook-up Reduced mode: Weather-compensated
		b0:3	Heating mode/reduced mode: With room temperature hook-up
b2:8	Only for heating circuit with mixer and remote control, and for the heating circuit, operation with room temperature hook-up must be programmed: Room influence factor 8 (only for weather-compensated control units)	b2:0	Without room influence
		b2:1 b2:64	Room influence factor adjustable from 1 to 64. The higher the value, the greater the room influence
b5:0	Only for heating circuit with mixer and remote control:	b5:1 b5:8	Heating circuit pump logic function, see the following table

"Heating circuit ..."/group 5 (cont.)

Coding in the delivered condition		Possible change	
	No room temperature-dependent heating circuit pump logic function (only for weather-compensated control units)		

Parameter address b5:...	With heating circuit pump logic function:	
	Heating circuit pump "OFF"	Heating circuit pump "ON"
1	$RT_{\text{actual}} > RT_{\text{set}} + 5 \text{ K}$	$RT_{\text{actual}} < RT_{\text{set}} + 4 \text{ K}$
2	$RT_{\text{actual}} > RT_{\text{set}} + 4 \text{ K}$	$RT_{\text{actual}} < RT_{\text{set}} + 3 \text{ K}$
3	$RT_{\text{actual}} > RT_{\text{set}} + 3 \text{ K}$	$RT_{\text{actual}} < RT_{\text{set}} + 2 \text{ K}$
4	$RT_{\text{actual}} > RT_{\text{set}} + 2 \text{ K}$	$RT_{\text{actual}} < RT_{\text{set}} + 1 \text{ K}$
5	$RT_{\text{actual}} > RT_{\text{set}} + 1 \text{ K}$	$RT_{\text{actual}} < RT_{\text{set}}$
6	$RT_{\text{actual}} > RT_{\text{set}}$	$RT_{\text{actual}} < RT_{\text{set}} - 1 \text{ K}$
7	$RT_{\text{actual}} > RT_{\text{set}} - 1 \text{ K}$	$RT_{\text{actual}} < RT_{\text{set}} - 2 \text{ K}$
8	$RT_{\text{actual}} > RT_{\text{set}} - 2 \text{ K}$	$RT_{\text{actual}} < RT_{\text{set}} - 3 \text{ K}$

Coding in the delivered condition		Possible change	
C5:20	Electronic minimum flow temperature limit 20 °C (only in operation with standard room temperature; only for weather-compensated control units)	C5:1 to C5:127	Minimum limit adjustable from 1 to 127 °C (limited by boiler-specific parameters)
C6:74	Electronic maximum flow temperature limit 74 °C (only for weather-compensated control units)	C6:10 to C6:127	Maximum limit adjustable from 10 to 127 °C (limited by boiler-specific parameters)
d3:14	Heating curve slope = 1.4	d3:2 to d3:35	Heating curve slope adjustable from 0.2 to 3.5 (see page 70)
d4:0	Heating curve level = 0	d4:-13 to d4:40	Heating curve level adjustable from -13 to 40 (see page 70)

"Heating circuit ..."/group 5 (cont.)

Coding in the delivered condition		Possible change	
d5:0	With external heating program changeover (observe setting for coding addresses "3A", "3b" and "3C" in group " General "). Heating program switches to "Constant central heating with reduced room temperature" or "Standby mode" (subject to the settings of the set reduced room temperature) (only for weather-compensated control units).	d5:1	The heating program changes to "Constant operation with standard room temperature".
d6:0	Heating circuit pump stays in control mode at signal "External blocking"	d6:1	Heating circuit pump stops at signal "External blocking" (subject to coding addresses "3A", "3b" and "3C")
		d6:2	Heating circuit pump starts at signal "External blocking" (subject to coding addresses "3A", "3b" and "3C")
d7:0	Heating circuit pump stays in control mode at signal "External demand"	d7:1	Heating circuit pump stops at signal "External demand" (subject to coding addresses "3A", "3b" and "3C")
		d7:2	Heating circuit pump starts at signal "External demand" (subject to coding addresses "3A", "3b" and "3C")
d8:0	With extension EA1: No heating program changeover.	d8:1	Heating program changeover via input DE1.
		d8:2	Heating program changeover via input DE2.

"Heating circuit ..."/group 5 (cont.)

Coding in the delivered condition		Possible change	
		d8:3	Heating program change-over via input DE3.
E1:1	Do not adjust		
E2:50	With remote control: No display correction for the actual room temperature (only for weather-compensated control units)	E2:0 to E2:49 E2:51 to E2:99	Display correction -5 K to Display correction -0.1 K to Display correction +0.1 K to Display correction +4.9 K
E5:0	Do not adjust		
E6:...	Only for heating systems without a heating circuit with mixer: Maximum speed of the internal variable speed heating circuit pump in % of the max. speed in standard mode. Value is specified by boiler-specific parameters (only for weather-compensated control units)	E6:0 to E6:100	Maximum speed adjustable from 0 to 100 %
E7:30	Only for heating systems without a heating circuit with mixer: Minimum speed of the internal variable speed heating circuit pump: 30 % of the max. speed (only for weather-compensated control units)	E7:0 to E7:100	Minimum speed adjustable from 0 to 100 % of the maximum speed
E8:1	Only for heating systems without a heating circuit with mixer:	E8:0	Speed subject to the setting in coding address "E7"

"Heating circuit ..."/group 5 (cont.)

Coding in the delivered condition		Possible change	
	Minimum speed of the internal variable speed heating circuit pump in operation with reduced room temperature subject to the setting in coding address "E9" (only for weather-compensated control units)		
E9:45	Only for heating systems without a heating circuit with mixer: Speed of the internal variable speed heating circuit pump: 45 % of the max. speed during operation with reduced room temperature (only for weather-compensated control units)	E9:0 to E9:100	Speed adjustable from 0 to 100 % of the maximum speed during operation with reduced room temperature
F1:0	Screed drying disabled (only for weather-compensated control units)	F1:1 to F1:6	Only for heating circuit with mixer: Screed drying adjustable in accordance with 6 selectable temperature/time profiles (see page 161)
		F1:15	Constant flow temperature 20 °C
F2:8	Time limit for party mode or external heating program changeover via pushbutton: 8 h (only for weather-compensated control units)* ¹	F2:0	No time limit for party mode** ¹
		F2:1 to	Time limit adjustable from 1 to 12 h** ¹

*¹ In the "Heating and DHW" program, party mode ends **automatically** when the system changes over to operation with standard room temperature.

"Heating circuit ..."/group 5 (cont.)

Coding in the delivered condition		Possible change	
	<p>Note Observe settings of coding addresses "3A", "3b" and "3C" in group "General", as well as "d5" and "d8" in group "Heating circuit..."</p>	F2:12	
F5:12	Run-on time of the internal circulation pump in heating mode: 12 min (only for constant temperature control units)	F5:0	No run-on time for the internal circulation pump
		F5:1 to F5:20	Run-on time of the internal circulation pump adjustable from 1 to 20 min
F6:25	In the "Only DHW" operating mode, the internal circulation pump is permanently on (only for constant temperature control units)	F6:0	In the "Only DHW" operating mode, the internal circulation pump is permanently off
		F6:1 to F6:24	In operating mode "Only DHW", the internal circulation pump will be started 1 to 24 times per day for 10 minutes each time.
F7:25	In "Standby mode", the internal circulation pump is permanently on (only for constant temperature control units)	F7:0	In "Standby mode", the internal circulation pump is permanently off
		F7:1 to F7:24	In "Standby mode", the internal circulation pump will be started 1 to 24 times per day for 10 min each time
F8:-5	Temperature limit for terminating reduced mode -5 °C, see example on page 163. Observe the setting of coding address "A3". (only for weather-compensated control units)	F8:+10 to F8:-60	Temperature limit adjustable from +10 to -60 °C
		F8:-61	Function disabled

"Heating circuit ..."/group 5 (cont.)

Coding in the delivered condition		Possible change	
F9:-14	Temperature limit for raising the reduced set room temperature -14 °C; see example on page 163 (only for weather-compensated control units)	F9:+10 to F9:-60	Temperature limit for raising the set room temperature to the value selected for standard mode adjustable from +10 to -60 °C
FA:20	Raising the set boiler water or flow temperature by 20 % when changing from operation with reduced room temperature to operation with standard room temperature. See example on page 164 (only for weather-compensated control units)	FA:0 to FA:50	Temperature rise adjustable from 0 to 50 %
Fb:60	Duration of the set boiler water or flow temperature rise (see coding address "FA") 60 min. See example on page 164 (only for weather-compensated control units)	Fb:0 to Fb:300	Duration adjustable from 0 to 300 min

Service menu

Weather-compensated control unit

Calling up the service menu

1. Press **OK** and **≡** simultaneously for approx. 4 s.
2. Select required menu. See following diagram.

Exiting the service menu

1. Select **"Terminate service?"**.
2. Select **"Yes"**.
3. Confirm with **OK**.

Note

The system exits the service level automatically after 30 min.

Constant temperature control unit

1. Press **OK** and **≡** simultaneously for approx. 4 s.
"P" flashes on the display.
2. Select required function. See the following pages.

1. Select **"Serv"** **⑦** with **▶**.
2. Confirm with **OK**.
"OFF" flashes.
3. Confirm with **OK**.

Note

The system exits the service level automatically after 30 min.

Overview of service menu for weather-compensated mode

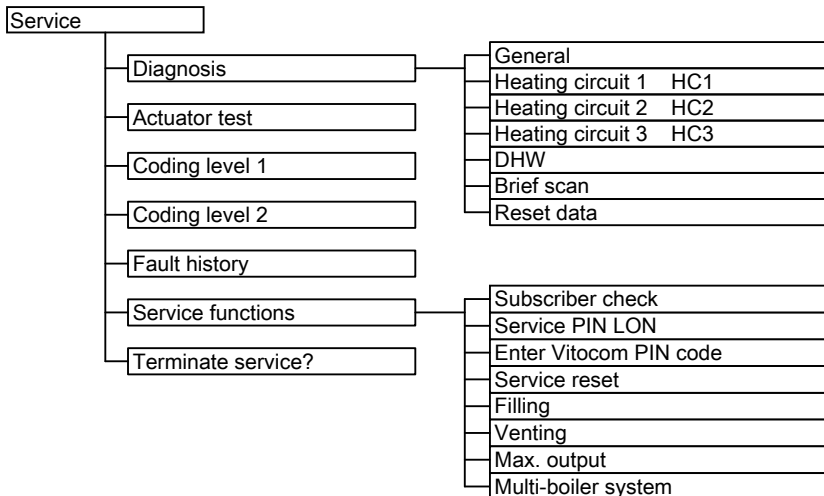

Service menu (cont.)

Note

Do **not** adjust menu point "**Multi-boiler system**".

This menu point changes the control unit to a constant temperature control unit in a multi-boiler system.

Diagnosis

Operating data

Weather-compensated control unit

Calling up operating data

- Operating data can be scanned in six areas. See "**Diagnosis**" in the service menu overview.
- Operating data on heating circuits with mixers and solar can only be called up if the components are installed in the system.
- For further information on operating data, see chapter "Brief scan".

Constant temperature control unit

- Operating data can be called up in the "**i**" menu.
- For further information on operating data, see chapter "Brief scan".

Calling up operating data

Service menu:

1. Press **OK** and  simultaneously for approx. 4 s.
2. "**Diagnosis**"
3. Select required group, e.g. "**General**".

Note

"- - -" appears on the display if a sensor that has been scanned is faulty.

Service menu:

1. Press **OK** and  simultaneously for approx. 4 s.
2. Select required information with **▲/▼**.

Note

"- - -" appears on the display if a sensor that has been scanned is faulty.

Diagnosis (cont.)

Weather-compensated control unit

Resetting operating data

Saved operating data (e.g. hours run) can be reset to "0".

The value "Adjusted outside temp" is reset to the actual value.



Service menu:

1. Press **OK** and  simultaneously for approx. 4 s.
2. **"Diagnosis"**
3. **"Reset data"**
4. Select required value (e.g. **"Burner starts"**) or **"All details"**.

Constant temperature control unit

Saved operating data (e.g. hours run) can be reset to "0".

Service menu:

1. Press **OK** and  simultaneously for approx. 4 s.
2. Select required information with / .
3. Confirm with **OK**; **"H"** flashes.
4. Confirm with **OK**; the value is reset.

Brief scan

In the brief scan, you can scan temperatures, software versions and connected components, for example.

Weather-compensated control unit

Service menu:

1. Press **OK** and  simultaneously for approx. 4 s.
2. **"Diagnosis"**
3. **"Brief scan"**.
4. Press **OK**.

The display shows 9 lines with 6 fields each.

Diagnosis brief scan

1:	1	F	0	A	1	2
2:	0	0	0	0	0	0
3:	0	0	0	0	0	0
4:	0	0	0	0	0	0

Select with 

Diagnosis (cont.)

For an explanation of the relevant values in the individual lines and fields, see the following table:

Line (brief scan)	Field					
	1	2	3	4	5	6
1:	System schemes 01 to 10		Software version Control unit		Software version Programming unit	
2:	0	0	Appliance version		Device identification ZE-ID	
3:	0		Number of KM BUS subscribers		0	0
4:	Software version Burner control unit		Type Burner control unit		Burner control unit version	
5:	Internal details for calibration			0	Software version, extension AM1	Software version, extension EA1
6:	0	0	0	0	0	0
7:	LON Subnet address/system number		LON Node address		0	
8:	LON SBVT configuration	LON Software version communication coprocessor	LON Neuron chip software version		Number of LON subscribers	

Diagnosis (cont.)

Line (brief scan)	Field					
	1	2	3	4	5	6
9:	Heating circuit A1 (without mixer) Remote control 0: Without 1: Vitotrol 200A/200 RF 2: Vitotrol 300A/300 RF or Vitocomfort	Software version, remote control	Heating circuit M2 (with mixer) Remote control 0: Without 1: Vitotrol 200A/200 RF 2: Vitotrol 300A/300 RF or Vitocomfort	Software version, remote control	Heating circuit M3 (with mixer) Remote control 0: Without 1: Vitotrol 200A/200 RF 2: Vitotrol 300A/300 RF or Vitocomfort	Software version, remote control
10: (only for KM BUS circulation pumps)	Internal circulation pump Variable speed pump 0: Without 1: Wilo 2: Grundfos	Software version, variable speed pump 0: No variable speed pump	0	0	0	0
11:	0	0	Software version Mixer extension heating circuit M2 0: No mixer extension	0	Software version Mixer extension heating circuit M3 0: No mixer extension	0

Diagnosis (cont.)



Constant temperature control unit

Service menu:

1. Press **OK** and  simultaneously for approx. 4 s.







"" flashes on the display.

2. Confirm with **OK**.

3. Select the required scan with /.
For example, "**A**" for "Max. output"
(see following table):

4. Confirm selected scan with **OK**.

For explanations of individual scans, see the following table:

Brief scan	Display				
					
0		System scheme	Software version Control unit		Software version Programming unit
1			Adjusted outside temperature		
3			Set boiler water temperature		
4			Common demand temperature		
5			Set cylinder temperature		
6		Number of KM BUS subscribers		Number of LON subscribers	
7	SNVT configuration 0: Auto 1: Tool	Software version Communication coprocessor		Software version LON module	
8		Subnet address/system number		Node address	
9		Burner control unit type		Device type	
A	Diverter valve status 1: Heating 2: Central position 3: DHW heating	0	Max. heating output in %		
b		Boiler coding card (hexadecimal)			
C		Version Device		Version Burner control unit	

Diagnosis (cont.)

Brief scan		Display			
0	0	0	0	0	0
d				Variable speed pump 1 Wilo 2 Grundfos	Software version Variable speed pump 0: no variable speed pump
E ①		Software version Burner control unit			
F ①	Setting of coding address "53"	Internal details for calibration			
Extension AM1					
F ②	Software version	Output A1 configuration (value corresponds to coding address "33" setting)	Output A1 switching state 0: OFF 1: ON	Output A2 configuration (value corresponds to coding address "34" setting)	Output A2 switching state 0: OFF 1: ON
Extension EA1					
F ③	Output 157 configuration (value corresponds to setting of coding address "36" in group 1 "General")	Output 157 switching state 0: OFF 1: ON	Input DE1 switching state 0: Open 1: Closed	Input DE2 switching state 0: Open 1: Closed	Input DE3 switching state 0: Open 1: Closed
F ④	Software version		External hook-up 0 – 10 V Display in %		
OpenTherm extension (if installed)					
F ⑨	Software version	DHW heating status	External hook-up 0 – 10 V Display in %		

Checking outputs (actuator test)

Weather-compensated control unit





1. Press **OK** and  simultaneously for approx. 4 s.
2. **"Actuator test"**

The following relay outputs can be controlled subject to system design:

Display		Explanation
All actuators	OFF	All actuators are off
Base load	ON	Burner operates at minimum output; internal pump starts
Full load	ON	Burner operates at maximum output; internal pump starts
Output, internal	ON	Internal output 20 active (internal circulation pump)
Output 21/28	ON	Internal output 21 active (only if circulation pump is connected)
Valve	Heating	Diverter valve set to heating mode
Valve	Centre	Diverter valve in central position (filling/draining)
Valve	DHW	Diverter valve set to DHW mode
Htg circ pump HC2	ON	Heating circuit pump output enabled (extension to heating circuit with mixer)
Mixer HC2	Open	"Mixer open" output enabled (extension to heating circuit with mixer)
Mixer HC2	Close	"Mixer close" output enabled (extension to heating circuit with mixer)
Htg circ pump HC3	ON	Heating circuit pump output enabled (extension to heating circuit with mixer)
Mixer HC3	Open	"Mixer open" output enabled (extension to heating circuit with mixer)
Mixer HC3	Close	"Mixer close" output enabled (extension to heating circuit with mixer)
Outp. int. exten. H1	ON	Output at internal extension enabled
AM1 output 1	ON	Output A1 at extension AM1 enabled
AM1 output 2	ON	Output A2 at extension AM1 enabled
EA1 output 1	ON	Contact P - S at plug 157 of extension EA1 closed

Checking outputs (actuator test) (cont.)

Constant temperature control unit

1. Press **OK** and  simultaneously for approx. 4 s. "🔧" flashes on the display.
2. Select "🔧" with  and confirm with **OK**.
3. Select required actuator (output) with / (see following table):
4. Confirm selected actuator with **OK**.
The display shows the number for the activated actuator and "**ON**".

The following actuators (relay outputs) can be controlled subject to system design:

Display	Explanation
0	All actuators are off
1	Burner operates at minimum output; internal pump starts
2	Burner operates at maximum output; internal pump starts
3	Internal output 20 active (internal circulation pump)
4	Diverter valve set to heating mode
5	Diverter valve in central position (filling/draining)
6	Diverter valve set to DHW mode
10	Internal extension output enabled
19	Contact P - S at plug 157 of extension EA1 closed
20	Output A1 at extension AM1 enabled
21	Output A2 at extension AM1 enabled
22	Internal output 21 active (only if circulation pump is connected)

Fault display

Weather-compensated control unit

In the event of a fault, red fault indicator **(A)** flashes. "**△**" flashes on the display and "**Fault**" is shown.

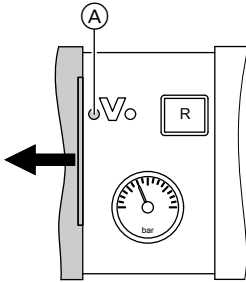

The fault code is displayed with **OK**. For an explanation of the fault code, see the following pages. For some faults, the type of fault is also displayed in plain text.

Acknowledging a fault

Follow the instructions on the display.

Note

- The fault message is transferred to the standard menu.
- Any fault message facility, if connected, will be switched off.
- If an acknowledged fault is not remedied, the fault message will be re-displayed the following day and the fault message facility restarted.

Calling up acknowledged faults

Select "**Fault**" in the standard menu. The current faults will be displayed in a list.

Calling up fault codes from the fault memory (fault history)

The 10 most recent faults (including resolved ones) are saved and can be scanned. Faults are sorted by date.

1. Press **OK** and **≡** simultaneously for approx. 4 s.
2. "**Fault history**"
3. "**Display?**"

Deleting fault history

1. Press **OK** and **≡** simultaneously for approx. 4 s.
2. "**Fault history**"
3. "**Delete?**"

Fault display (cont.)

Constant temperature control unit

In the event of a fault, red fault indicator (A) flashes. The two-digit fault code and (subject to the type of fault) "△" or "⚡" flash on the programming unit display.

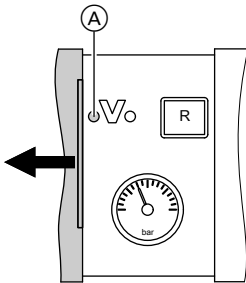

Other current faults can be displayed with ▲/▼. For an explanation of the fault codes, see the following pages.



Example: Fault code "50"

Acknowledge a fault

Press **OK**; the standard display is shown again.

A fault message facility, if connected, will be switched OFF.

If an acknowledged fault is not remedied, the fault message will be re-displayed the following day and the fault message facility restarted.

Calling up acknowledged faults

Press **OK** for approx. 4 s.

The 10 most recent faults (including resolved ones) are saved and can be called up.

Calling up fault codes from the fault memory (fault history)

The 10 most recent faults (including those remedied) are saved and can be called up.

Faults are sorted by date.

1. Press **OK** and **≡** simultaneously for approx. 4 s.
2. Select "△" and activate fault history with **OK**.
3. Select fault messages with ▲/▼.

Deleting fault history

While the list is displayed, press **OK** until ⚡ flashes. Confirm with **OK**.

Fault codes

Dis-played fault code	Const.	Weath.-comp.	System char-acteristics	Cause	Measures
0F			Control mode	Service "0F" is only displayed in the fault history	Service required Note <i>After servicing, select code "24:0".</i>
10	X	X	Controls as if the outside temperature were 0 °C	Short circuit, outside temperature sensor	Check outside temperature sensor (see page 139)
18	X	X	Controls as if the outside temperature were 0 °C	Lead break, outside temperature sensor	Check outside temperature sensor (see page 139)
19	X	X	Controls as if the outside temperature were 0 °C	Communication error, wireless outside temperature sensor	Check wireless connection (place wireless outside temperature sensor close to the wireless base station). Log off outside temperature sensor then log on again. Replace if required (see "Wireless base station" installation and service instructions)
20	X	X	Regulates with-out flow temperature sensor (low loss header)	Short circuit, system flow temperature sensor	Check low loss header sensor (see page 140)

Fault codes (cont.)

Dis- played fault code	Const.	Weath.- comp.	System char- acteristics	Cause	Measures
28	X	X	Regulates with- out flow tem- perature sen- sor (low loss header)	Lead break, system flow temperature sensor	Check low loss header sensor (see page 140) If no low loss head- er sensor is con- nected, set code 52:0
30	X	X	Burner blocked	Short circuit, boiler water temperature sensor	Check the boiler water temperature sensor (see page 140)
38	X	X	Burner blocked	Lead break, boiler water temperature sensor	Check the boiler water temperature sensor (see page 140)
40		X	Mixer closes	Short circuit, flow tempera- ture sensor, heating circuit 2 (with mixer)	Check flow temper- ature sensor (see page 148)
44		X	Mixer closes	Short circuit, flow tempera- ture sensor, heating circuit 3 (with mixer)	Check flow temper- ature sensor (see page 148)
48		X	Mixer closes	Lead break, flow tempera- ture sensor, heating circuit 2 (with mixer)	Check flow temper- ature sensor (see page 148)
4C		X	Mixer closes	Lead break, flow tempera- ture sensor, heating circuit 3 (with mixer)	Check flow temper- ature sensor (see page 148)



Fault codes (cont.)

Dis- played fault code	Const.	Weath.- comp.	System char- acteristics	Cause	Measures
50	X	X	No DHW heating	Short circuit, cylinder temperature sensor	Check the cylinder temperature sensor (see page 140)
51	X	X	No DHW heating	Short circuit, outlet temperature sensor	Check the outlet temperature sensor (see page 142)
58	X	X	No DHW heating	Lead break, cylinder temperature sensor	Check the cylinder temperature sensor (see page 140)
59	X	X	No DHW heating	Lead break, outlet temperature sensor	Check the outlet temperature sensor (see page 142)
A7		X	Control mode as per delivered condition	Programming unit faulty	Replace programming unit
A8		X	Burner blocked The venting program is started automatically (see page 77)	Air lock in the internal circulation pump or minimum flow rate not achieved	Vent the system if the fault message continues to be displayed
A9		X	If a heating circuit with mixer is connected, the burner operates at its lower heating output. If only one heating circuit without mixer is connected, the burner is blocked	Internal circulation pump blocked	Check the circulation pump

Fault codes (cont.)

Dis- played fault code	Const.	Weath.- comp.	System char- acteristics	Cause	Measures
b0	X	X	Burner blocked	Short circuit, flue gas tem- perature sen- sor	Check the flue gas temperature sen- sor (see page 144)
b1	X	X	Control mode as per deliv- ered condition	Communica- tion error, programming unit	Check connections and replace pro- gramming unit if re- quired
b4	X	X	Controls as if the outside temperature were 0 °C	Internal fault	Replace the control unit
b5	X	X	Control mode as per deliv- ered condition	Internal fault	Replace the control unit
b7	X	X	Burner blocked	Boiler coding card faulty	Plug in or replace boiler coding card
b8	X	X	Burner blocked	Lead break, flue gas tem- perature sen- sor	Check the flue gas temperature sen- sor (see page 144)
bA		X	Mixer regulates to 20 °C flow temperature	Communica- tion error, ex- tension kit for heating circuit 2 (with mixer)	Check the exten- sion kit connec- tions and coding
bb		X	Mixer regulates to 20 °C flow temperature	Communica- tion error, ex- tension kit for heating circuit 3 (with mixer)	Check the exten- sion kit connec- tions and coding

Fault codes (cont.)

Dis-played fault code	Const.	Weath.-comp.	System characteristics	Cause	Measures
bC		X	Control mode without remote control	Communication error, remote control Vitotrol heating circuit 1 (without mixer)	Check connections, cable, coding address "A0" in group "Heating circuit..."5/ and remote control configuration (see page 166). For wireless remote controls: Check connections, place remote control unit close to the boiler
bd		X	Control mode without remote control	Communication error, remote control Vitotrol heating circuit 2 (with mixer)	Check connections, cable, coding address "A0" in group "Heating circuit..."5 and remote control configuration (see page 166). For wireless remote controls: Check connections, place remote control unit close to the boiler

Fault codes (cont.)

Dis- played fault code	Const.	Weath.- comp.	System char- acteristics	Cause	Measures
bE		X	Control mode without remote control	Communication error, remote control Vitotrol heating circuit 3 (with mixer)	Check connections, cable, coding address "A0" in group "Heating circuit..." /5 and remote control configuration (see page 166). For wireless remote controls: Check connections, place remote control unit close to the boiler
bF		X	Control mode	Incorrect LON communication module	Replace LON communication module
C1	X	X	Control mode	Communication error, extension EA1	Check connections Without extension EA1: Set code "5b:0" in group "General"/1
C3	X	X	Control mode	Communication error, extension AM1	Check connections Without extension AM1: Set code "32:0" in group "General"/1
C4	X	X	Control mode	Communication error, OpenTherm extension	Check OpenTherm extension
C5	X	X	Control mode, max. pump speed	Communication error, variable speed internal pump	Check coding address setting "30" in group "Boiler"/ 2

Fault codes (cont.)

Dis-played fault code	Const.	Weath.-comp.	System characteristics	Cause	Measures
Cd			Control mode	Communication error, Vitocom 100	Check connections and Vitocom 100 (see separate installation and service instructions). Without Vitocom 100: Set code "95:0" in group "General"/1
CF		X	Control mode. No communication via LON	Communication error, LON communication module	Check LON communication module and replace if required. If no LON communication module is installed, set code "76:0" in group "General"/1
d6	X	X	Control mode	Input DE1 reports a fault at extension EA1	Remove fault at appliance concerned
d7	X	X	Control mode	Input DE2 at extension EA1 reports a fault	Remove fault at appliance concerned
d8	X	X	Control mode	Input DE3 at extension EA1 reports a fault	Remove fault at appliance concerned
dA		X	Control mode without room influence	Short circuit, room temperature sensor, heating circuit 1 (without mixer)	Check room temperature sensor, heating circuit 1

Fault codes (cont.)

Dis- played fault code	Const.	Weath.- comp.	System char- acteristics	Cause	Measures
db		X	Control mode without room influence	Short circuit, room temper- ature sensor, heating circuit 2 (with mixer)	Check room tem- perature sensor, heating circuit 2
dC		X	Control mode without room influence	Short circuit, room temper- ature sensor, heating circuit 3 (with mixer)	Check room tem- perature sensor, heating circuit 3
dd		X	Control mode without room influence	Lead break, room temper- ature sensor, heating circuit 1 (without mixer)	Check room tem- perature sensor for heating circuit 1 and remote control configuration (see page 166)
dE		X	Control mode without room influence	Lead break, room temper- ature sensor, heating circuit 2 (with mixer)	Check room tem- perature sensor for heating circuit 2 and remote control configuration (see page 166)
dF		X	Control mode without room influence	Lead break, room temper- ature sensor, heating circuit 3 (with mixer)	Check room tem- perature sensor for heating circuit 3 and remote control configuration (see page 166)
E0		X	Control mode	Fault, exter- nal LON sub- scriber	Check connections and LON subscri- bers



Fault codes (cont.)

Dis-played fault code	Const.	Weath.-comp.	System characteristics	Cause	Measures
E1	X	X	Burner in a fault state	Ionisation current too high during calibration	Check gap between ionisation electrode and burner gauze assembly (see page 52). In open flue operation, prevent high incidence of dust in the combustion air. Press reset button R
E3	X	X	Burner in a fault state	Heat transfer too low during calibration. Temperature limiter has shut down	Ensure adequate heat transfer. Press reset button R
E4	X	X	Burner blocked	Fault, 24 V supply voltage	Replace control unit
E5	X	X	Burner blocked	Fault, flame amplifier	Replace control unit
E6	X	X	Burner blocked	System pressure too low	Top up with water

Fault codes (cont.)

Dis- played fault code	Const.	Weath.- comp.	System char- acteristics	Cause	Measures
E7	X	X	Burner in a fault state	Ionisation current too low during calibration	<p>Check ionisation electrode:</p> <ul style="list-style-type: none"> ■ Distance to burner gauze assembly (see page 52) ■ Contamination of electrode ■ Connecting lead and plug-in connections <p>Check flue system; remedy flue gas recirculation if required. Press reset button R</p>
E8	X	X	Burner in a fault state	The ionisation current lies outside the permissible range	<p>Check gas supply (gas pressure and gas flow switch), gas train and connecting lead. Check allocation of gas type (see page 44).</p> <p>Check ionisation electrode:</p> <ul style="list-style-type: none"> ■ Distance to burner gauze assembly (see page 52) ■ Contamination of electrode <p>Press reset button R</p>

Fault codes (cont.)

Dis-played fault code	Const.	Weath.-comp.	System characteristics	Cause	Measures
EA	X	X	Burner in a fault state	Ionisation current outside permissible range during calibration (deviation from previous level too great)	Check flue system; remedy flue gas recirculation if required. In open flue operation, prevent high incidence of dust in the combustion air. Press reset button R Following several unsuccessful reset attempts, replace boiler coding card and press reset button R
Eb	X	X	Burner in a fault state	Repeated flame loss during calibration	Check gap between ionisation electrode and burner gauze assembly (see page 52). Check allocation of gas type (see page 52). Check flue system; remedy flue gas recirculation if required. Press reset button R
EC	X	X	Burner in a fault state	Parameter fault during calibration	Press reset button R or Replace boiler coding card and press reset button R
Ed	X	X	Burner in a fault state	Internal fault	Replace control unit

Fault codes (cont.)

Dis- played fault code	Const.	Weath.- comp.	System char- acteristics	Cause	Measures
EE	X	X	Burner in a fault state	Flame signal is not present or too weak at burner start	<p>Check gas supply (gas pressure and gas flow switch). Check gas train. Check ionisation electrode and con- necting cable.</p> <p>Check ignition:</p> <ul style="list-style-type: none"> ■ Connecting leads to ignition module and igni- tion electrode ■ Ignition elec- trode gap and contamination (see page 52) <p>Check condensate drain. Press reset button R</p>



Fault codes (cont.)

Dis-played fault code	Const.	Weath.-comp.	System char-acteristics	Cause	Measures
EF	X	X	Burner in a fault state	Flame is lost immediately after it has formed (during the safety time)	<p>Check gas supply (gas pressure and gas flow switch). Check balanced flue system for flue gas recirculation.</p> <p>Check ionisation electrode (replace if necessary):</p> <ul style="list-style-type: none"> ■ Distance to burner gauze assembly (see page 52) ■ Contamination of electrode <p>Press reset button R</p>
F0	X	X	Burner blocked	Internal fault	Replace control unit
F1	X	X	Burner in a fault state	Flue gas temperature limiter has re-ponded	<p>Check heating system fill level. Vent the system.</p> <p>Press reset button R after flue system has cooled down</p>
F2	X	X	Burner in a fault state	Temperature limiter has re-ponded	<p>Check heating system fill level. Check circulation pump. Vent the system.</p> <p>Check temperature limiter and connecting cables.</p> <p>Press reset button R</p>

Fault codes (cont.)

Dis- played fault code	Const.	Weath.- comp.	System char- acteristics	Cause	Measures
F3	X	X	Burner in a fault state	Flame signal is already present at burner start	Check ionisation electrode and connecting cable. Press reset button R
F8	X	X	Burner in a fault state	Fuel valve closes too late	Check gas train. Check both control paths. Press reset button R
F9	X	X	Burner in a fault state	Fan speed too low during burner start	Check fan, fan connecting cables and power supply; check fan control. Press reset button R
FA	X	X	Burner in a fault state	Fan not in idle state	Check fan, fan connecting cables and fan control. Press reset button R
FC	X	X	Burner in a fault state	Gas train faulty, faulty modulation valve control or flue gas path blocked	Check gas train. Check flue system. Press reset button R
Fd	X	X	Burner in a fault state and additional fault b7 is displayed	Boiler coding card is missing	Insert the boiler coding card. Press reset button R Replace control unit if fault persists



Fault codes (cont.)

Dis- played fault code	Const.	Weath.- comp.	System char- acteristics	Cause	Measures
Fd	X	X	Burner in a fault state	Fault, burner control unit	Check ignition electrodes and connecting cables. Check whether a strong interference (EMC) field exists near the appliance. Press reset button R Replace control unit if fault persists
FE	X	X	Burner blocked or in a fault state	Boiler coding card or main PCB faulty, or incorrect boiler coding card	Press reset button R . If the fault persists, check the boiler coding card and replace boiler coding card or control unit if necessary
FF	X	X	Burner blocked or in a fault state	Internal fault or reset button R blocked	Start the appliance again. Replace the control unit if the appliance will not restart

Note

*In the case of subscriber faults, "**Subscriber fault ...**" is displayed.*

Repair

Putting control unit in maintenance position

If required for commissioning and servicing, the control unit can be put in a different position.

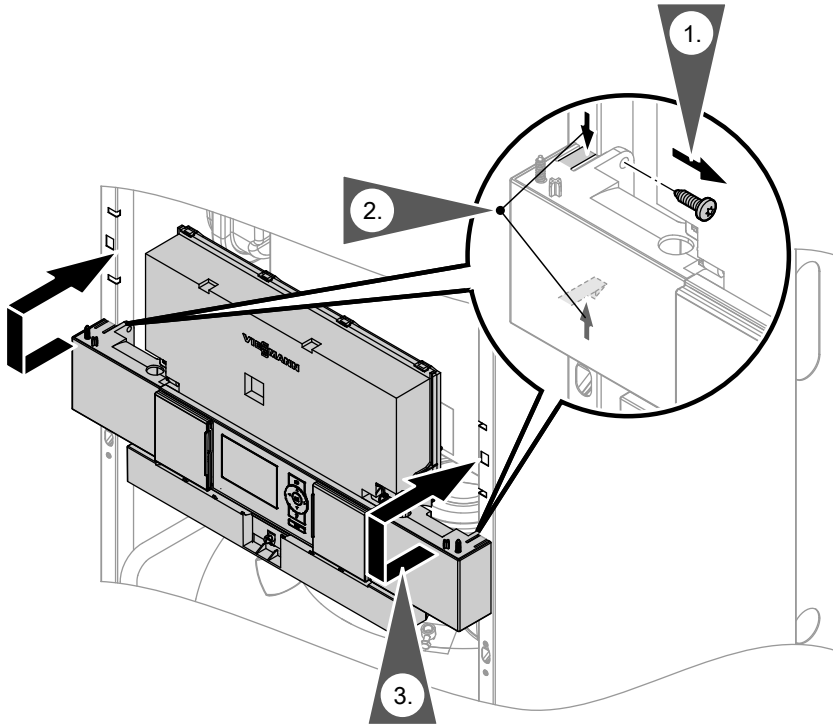

Repair (cont.)

Drain boiler on the heating water side

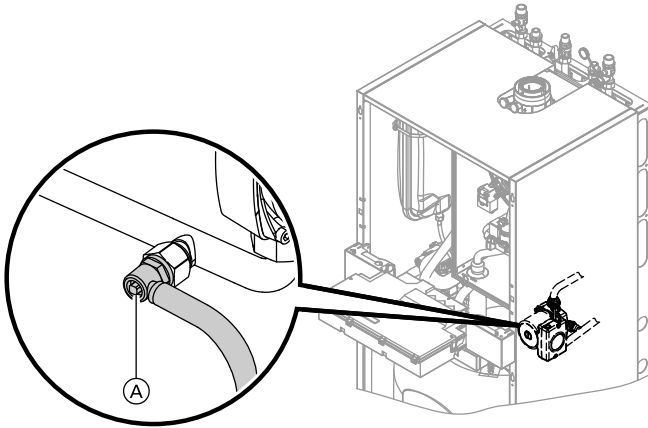

1. Close the shut-off valves on the heating water side.
2. Route hose at drain valve (A) into a suitable container or drain outlet.
3. Open drain valve (A) and drain the boiler as much as required.

Repair (cont.)

Checking the outside temperature sensor

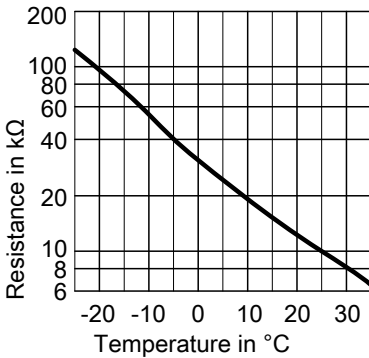
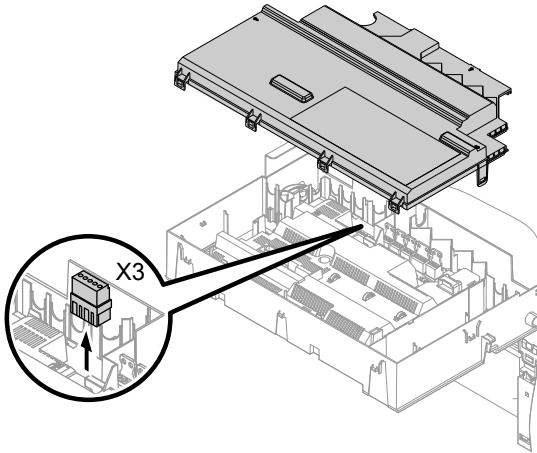

Sensor type: NTC 10 kΩ

1. Pull plug "X3" from the control unit.

2. Test the resistance of the outside temperature sensor across terminals "X3.1" and "X3.2" on the disconnected plug and compare it with the curve.
3. Where actual values deviate severely from the curve values, disconnect the wires at the sensor and repeat the test on the sensor itself.
4. Depending on the result, replace the lead or the outside temperature sensor.

Repair (cont.)

Checking the boiler temperature sensor, cylinder temperature sensor or low loss header flow temperature sensor

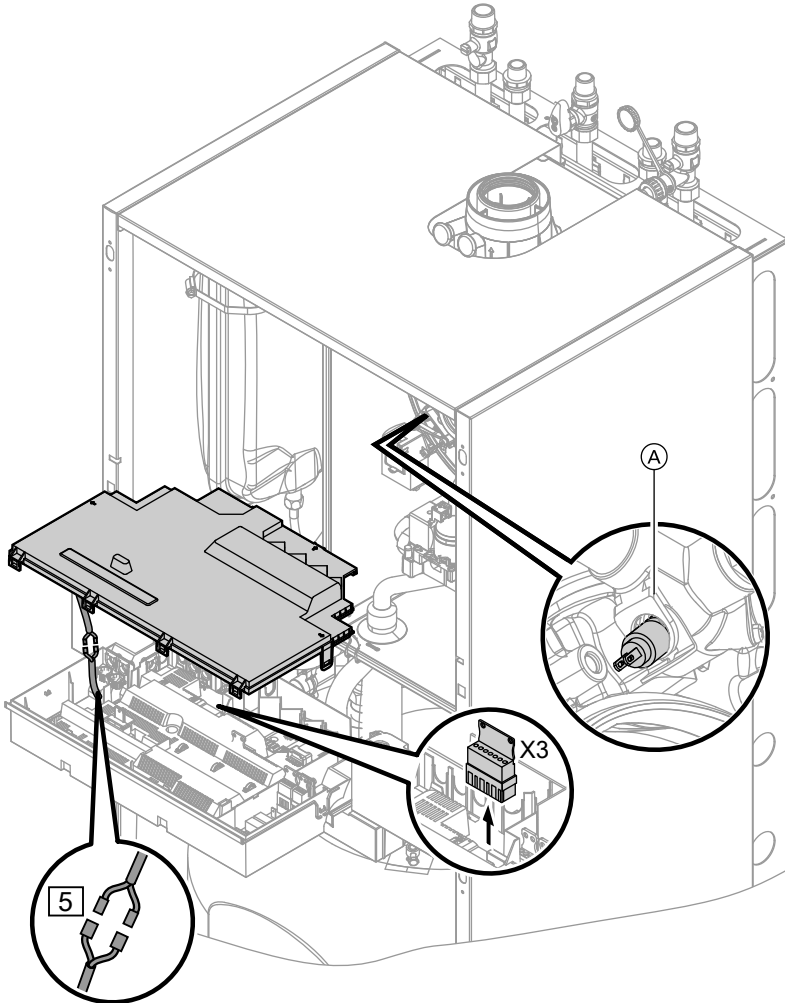

Repair (cont.)

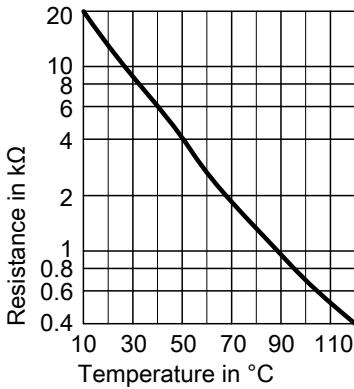

2. Check the sensor resistance and compare it with the curve.
3. Replace the sensor in the case of severe deviation.



Danger

The boiler water temperature sensor is immersed in the heating water (risk of scalding).

Drain the boiler on the heating water side before replacing the sensor.

Sensor type: NTC 10 kΩ

1. ■ **Boiler water temperature sensor**
Pull the leads from boiler water temperature sensor (A) and check the resistance.
- **Cylinder temperature sensor**
Pull plug [5] from the cable harness at the control unit and check the resistance.
- **Flow temperature sensor**
Pull plug "X3" from the control unit and check the resistance across terminals "X3.4" and "X3.5".

Repair (cont.)

Checking the outlet temperature sensor

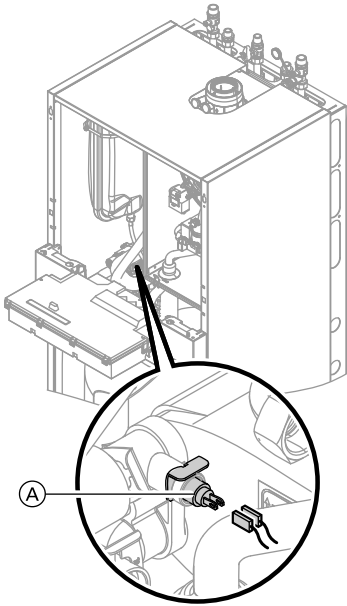

1. Pull leads from outlet temperature sensor (A).
2. Check the sensor resistance and compare it with the curve.
3. Replace the sensor in the case of severe deviation.



Danger

The outlet temperature sensor is immersed in the DHW (risk of scalding). Drain the DHW side of the boiler before replacing the sensor.

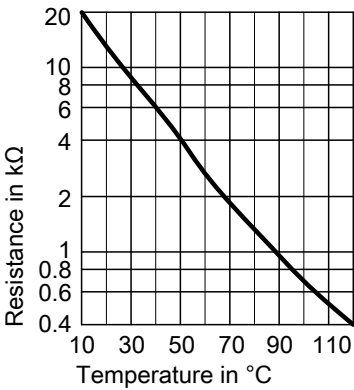

Sensor type: NTC 10 kΩ

Repair (cont.)

Checking the plate heat exchanger

Note

Drain the boiler on its heating water and DHW side.

During disassembly and once removed, small amounts of water may escape from the plate heat exchanger.

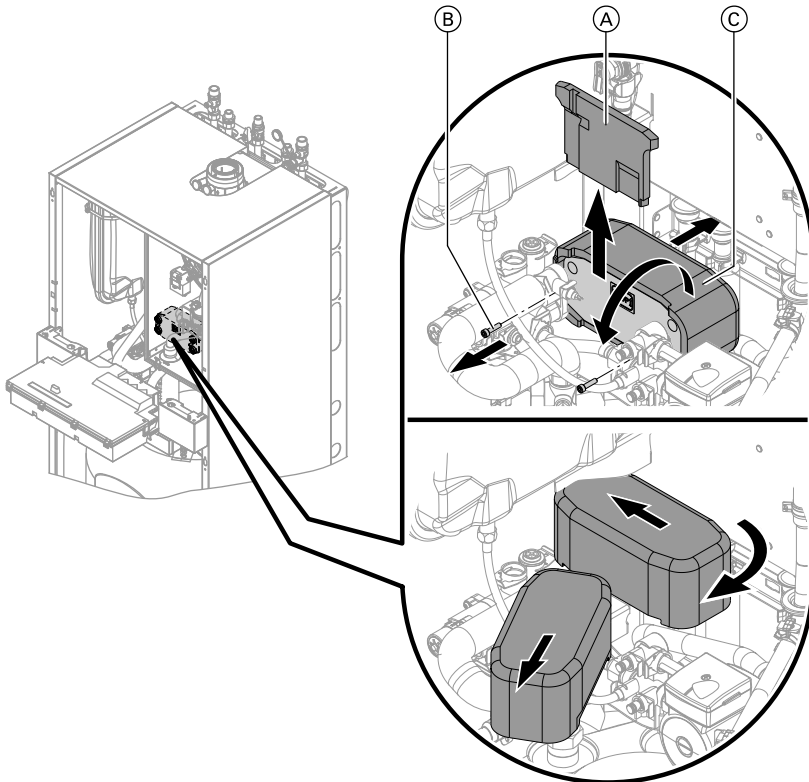

1. Shut off and drain the boiler on the heating water and DHW sides.
2. Release the side closures and pivot the control unit forward.
3. Remove the siphon (see page 54).
4. Push thermal insulation panel (A) upwards and remove.
5. Undo two screws (B) and pull out plate heat exchanger (C) through the front.

Repair (cont.)

6. Check the connections on the heating water and DHW side for contamination and scaling; if required, replace the plate heat exchanger.
7. Install in reverse order using new gaskets.

Checking the flue gas temperature sensor

The flue gas temperature sensor locks out the boiler when the permissible flue gas temperature is exceeded. Reset the interlock after the flue system has cooled down by pressing reset button **R**.

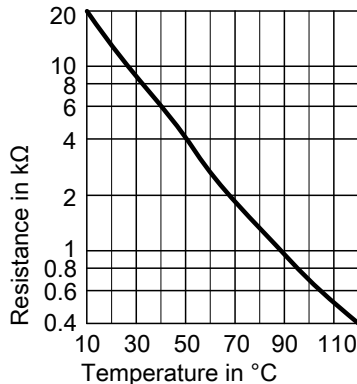
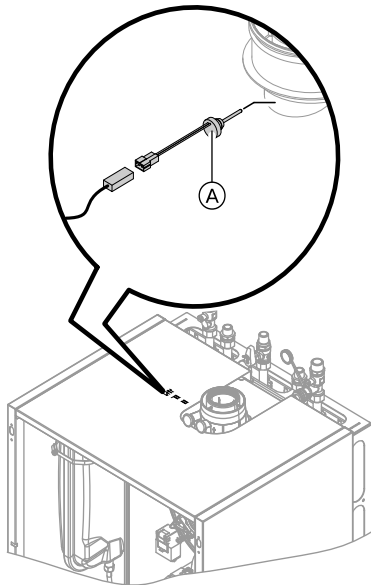

Sensor type: NTC 10 kΩ

1. Pull leads from flue gas temperature sensor (A).
2. Check the sensor resistance and compare it with the curve.
3. Replace the sensor in the case of severe deviation.

Fault "A3" during commissioning

During commissioning, the control unit checks whether the flue gas temperature sensor is correctly positioned.

If the flue gas temperature sensor is not positioned correctly, commissioning is cancelled and fault message A3 is displayed.

1. Check whether the flue gas temperature sensor is correctly inserted. See previous diagram.

Repair (cont.)

2. If necessary, correct the position of the flue gas temperature sensor or replace faulty flue gas temperature sensor.
3. Press reset button **R** and repeat commissioning.
The check is repeated until it is completed successfully.

Checking the temperature limiter

If the burner control unit cannot be reset after a fault shutdown, although the boiler water temperature is below approx. 75 °C, check the following:

1. Pull the leads from temperature limiter **(A)**.
2. Check the continuity of the temperature limiter with a multimeter.
3. Remove the faulty temperature limiter.
4. Coat the replacement temperature limiter with heat conducting paste and install it.
5. After commissioning, press reset button **R** on the control unit.

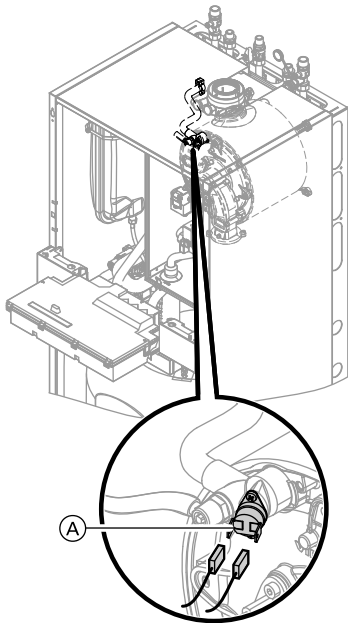

Repair (cont.)

Checking the fuse

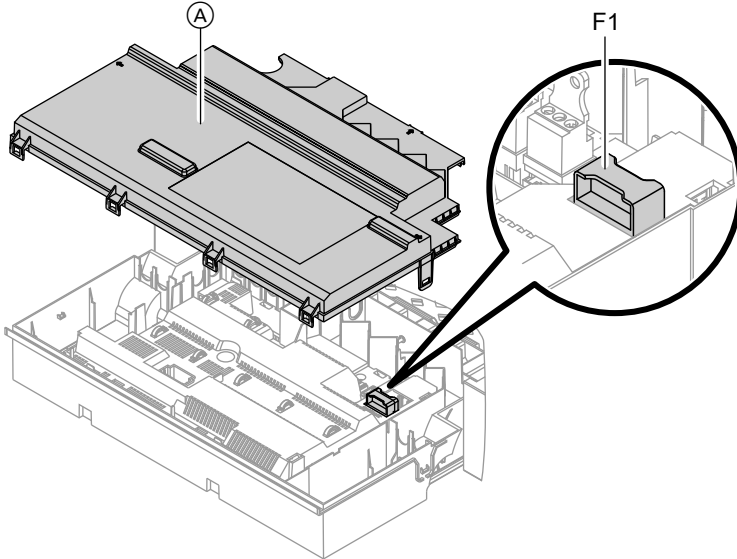



1. Switch off the power.
2. Release the side closures and pivot the control unit down.
3. Remove cover (A).
4. Check fuse F1 (see connection and wiring diagram).

Extension kit for heating circuit with mixer

Checking the setting of rotary selector S1

The rotary selector on the PCB of the extension kit defines the assignment to the relevant heating circuit.

Heating circuit	Rotary selector S1 setting
Heating circuit with mixer M2 (heating circuit 2)	2 
Heating circuit with mixer M3 (heating circuit 3)	4 

Repair (cont.)

Checking the rotational direction of the mixer motor

After being switched on, the boiler implements a self-test. During this, the mixer is opened and closed again.

Note

The mixer motor can also be set in motion via the actuator test (see chapter "Checking outputs").

Note the rotational direction of the mixer motor during its self-test.

Then set the mixer manually to "Open" again.

Note

The flow temperature sensor must now capture a higher temperature. If the temperature drops, either the motor is turning in the wrong direction or the mixer insert is incorrectly fitted.



Mixer installation instructions

Changing the rotational direction of the mixer motor (if required)

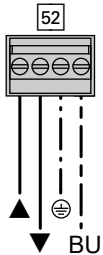

1. Remove the upper casing cover of the extension kit.



Danger

An electric shock can be life-threatening. Before opening the boiler, disconnect from the mains voltage, for example at the fuse or the mains isolator.

2. At plug **52**, swap the cores at terminals "▲" and "▼".
3. Refit the casing cover.

Repair (cont.)

Checking flow temperature sensor

Pressure drop curve

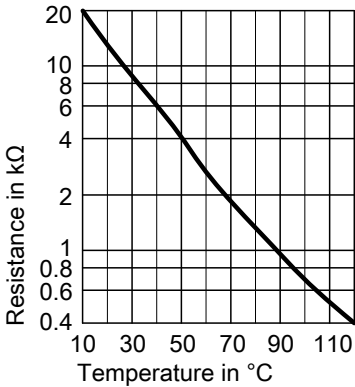

Sensor type: NTC 10 kΩ

1. Remove plug 2 (flow temperature sensor).
2. Check the sensor resistance and compare it with the curve. Replace the sensor in the case of severe deviation.

Checking the Vitotronic 200-H (accessory)

The Vitotronic 200-H is connected to the control unit via the LON cable. To test the connection, carry out a subscriber check at the boiler control unit (see page 74).

Constant temperature control unit

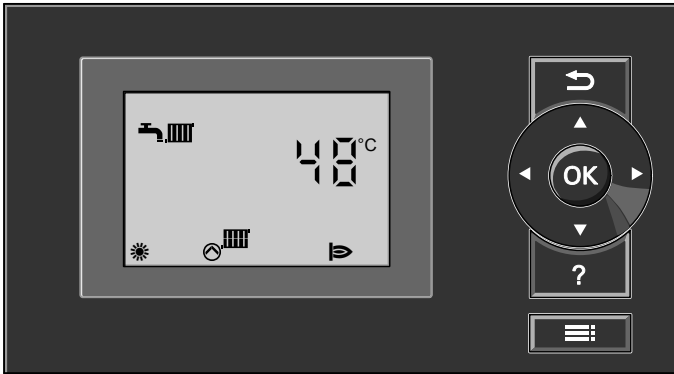

Heating mode

The selected set boiler water temperature will be maintained when a demand is being raised by the room thermostat and the heating program is set to DHW and central heating "☀️➡️". The boiler water temperature will be maintained at the default frost protection temperature when there is no demand.

The electronic temperature limiter inside the burner control unit limits the boiler water temperature. Flow temperature setting range: 20 to 74 °C.

DHW heating

The burner, the circulation pump and the 3-way valve are started or changed over if the cylinder temperature lies 2.5 K below the set cylinder temperature.

In the delivered condition, the set boiler water temperature is 20 K above the set cylinder temperature (adjustable via coding address 60 in group **"DHW"**). The burner will be switched off and the circulation pump run-on time will begin if the actual cylinder temperature exceeds the set cylinder temperature by 2.5 K.

Weather-compensated control unit

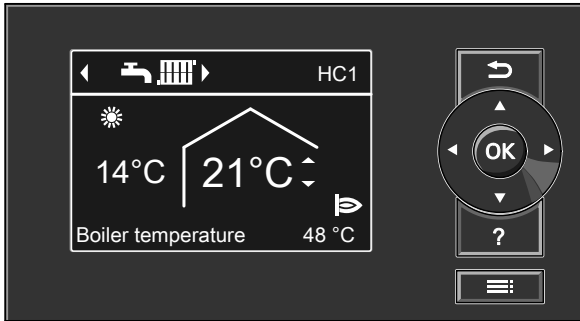

Heating mode

The control unit determines a set boiler water temperature subject to outside temperature or room temperature (if a room temperature-dependent remote control is connected) and to the slope/level of the heating curve.

The determined set boiler water temperature is transferred to the burner control unit. From the set and actual boiler water temperatures, the burner control unit calculates the modulation level and regulates the burner accordingly.

The electronic temperature limiter inside the burner control unit limits the boiler water temperature.

Heating the DHW primary store from cold

The heating circuit pump is switched ON and the 3-way diverter valve will be changed over, if the cylinder temperature sensor captures a temperature lower than the defaulted set value.

- The cylinder primary pump is switched ON if the boiler water temperature \geq set DHW temperature.
- The burner is switched ON if the boiler water temperature \leq set DHW temperature, and the cylinder primary pump is switched ON when the required boiler water temperature is reached.

The primary store is heated up to the set DHW temperature. Heating stops when the specified temperature has been reached at the cylinder temperature sensor.

After heating has ended, the cylinder primary pump and the 3-way diverter valve remain on for a further 30 s.

Weather-compensated control unit (cont.)

Reheating when DHW is drawn off

When DHW is drawn off, cold water enters at the bottom of the primary store.

The heating circuit pump is switched ON and the 3-way diverter valve is changed over, if the cylinder temperature sensor recognises a temperature lower than the set value.

- The cylinder primary pump is switched ON if the boiler water temperature \geq set DHW temperature.
- The burner is switched ON if the boiler water temperature \leq set DHW temperature, and the cylinder primary pump is switched ON when the required boiler water temperature is reached.

DHW is regulated to the set temperature via the outlet temperature sensor.

The primary store continues to be heated up after the draw off process has terminated, until the set DHW temperature has been reached at the cylinder temperature sensor.

The cylinder primary pump and the 3-way diverter valve remain on for a further 30 s.

Boosting DHW heating

This function is activated by specifying a second set DHW temperature via coding address 58 in group **"DHW"** and activating the fourth DHW phase for DHW heating.

Heating is boosted during the periods selected in this time phase.

Internal extensions

Internal extension H1

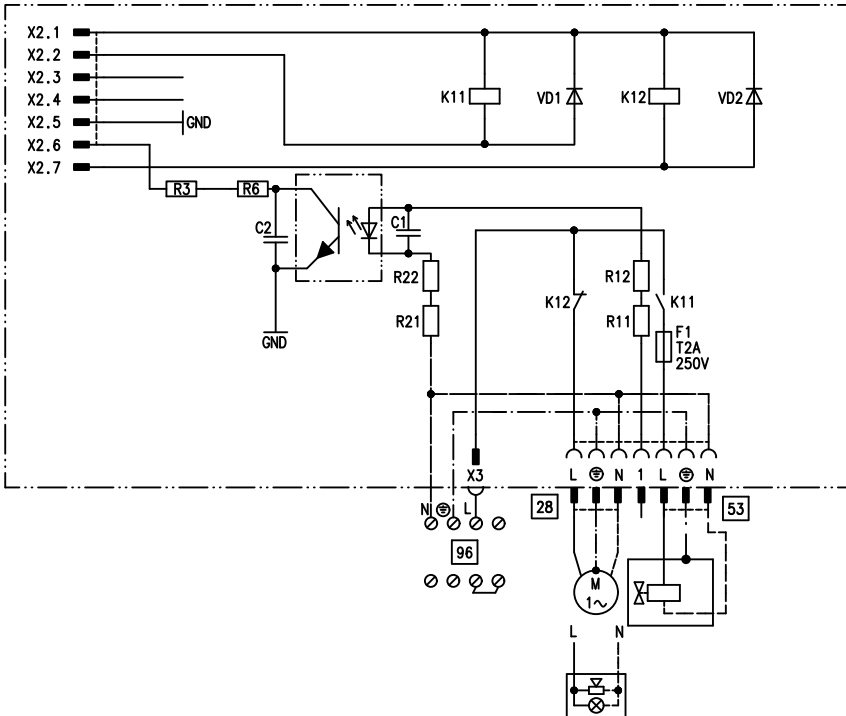

The internal extension is integrated into the control unit casing. The following alternative functions can be connected to relay output [28]. The function is assigned via coding address "53" in group **"General"**:

- Central fault message (code "53:0")
- DHW circulation pump (code "53:1") (only for weather-compensated operation)
- Heating circuit pump for heating circuit without mixer (code "53:2")
- Circulation pump for cylinder heating (code "53:3")

An external safety valve can be connected to connection [53].

Internal extensions (cont.)

Internal extension H2

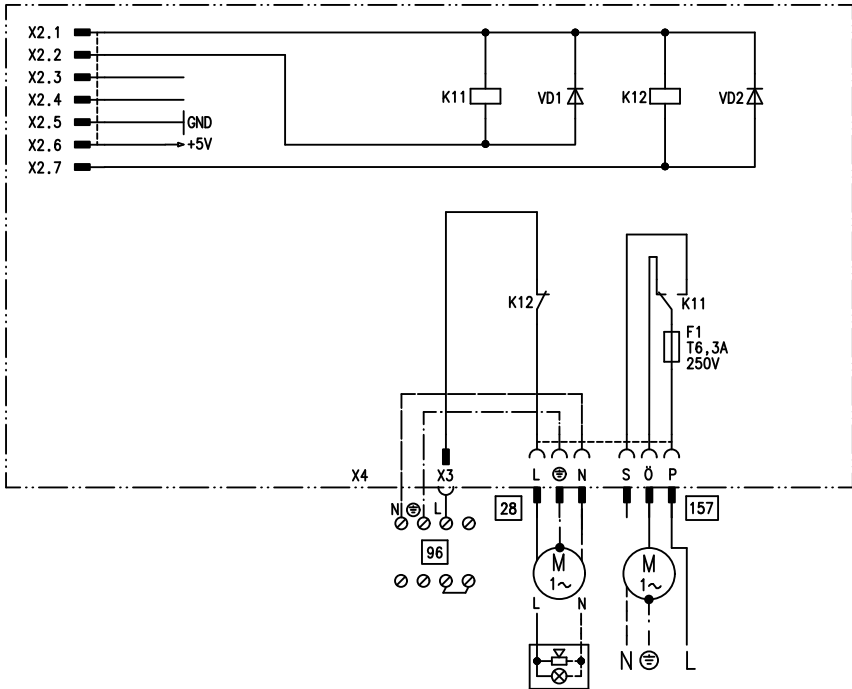

The internal extension is integrated into the control unit casing. The following alternative functions can be connected to relay output **28**. The function is assigned via coding address "53" in group **"General"**:

- Central fault message (code "53:0")
- DHW circulation pump (code "53:1") (only for weather-compensated operation)

- Heating circuit pump for heating circuit without mixer (code "53:2")
- Circulation pump for cylinder heating (code 53:3)

An extractor fan can be switched off via connection **157** when the burner starts.

External extensions (accessories)

Extension AM1

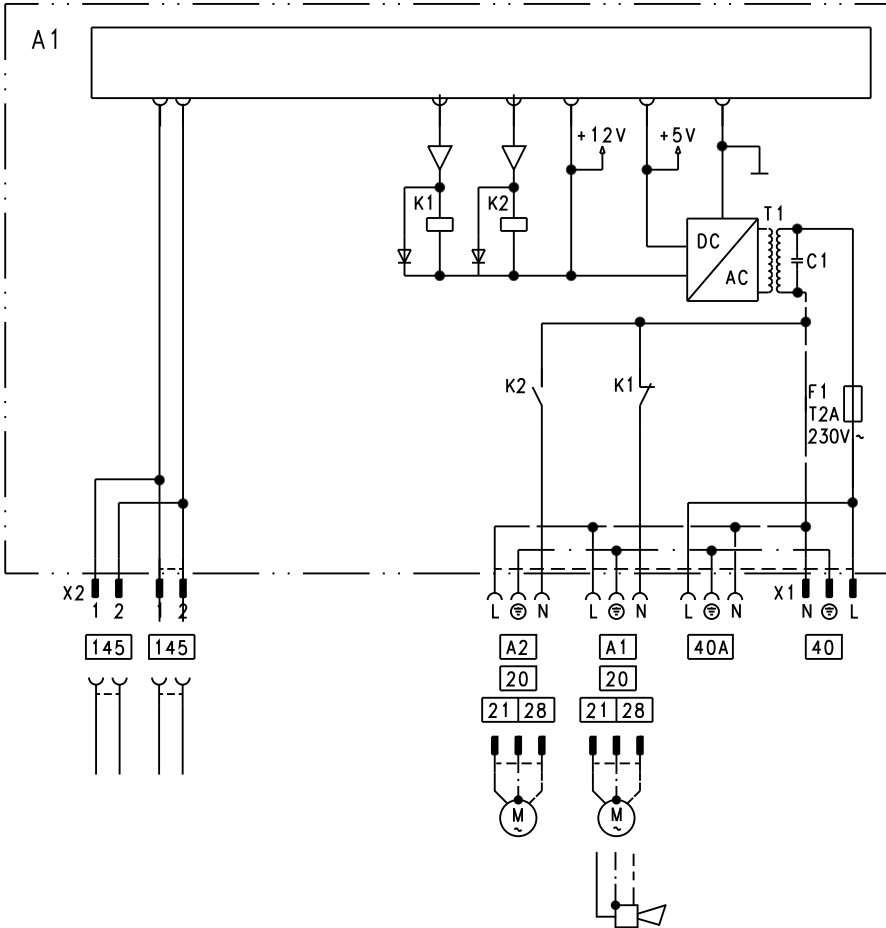

- A1 Circulation pump
- A2 Circulation pump
- 40 Power supply

- 40 A Power supply for additional accessories
- 145 KM BUS

External extensions (accessories) (cont.)

Functions

Select the output functions by means of the codes on the boiler control unit.

One of the following circulation pumps can be connected to each of the connections A1 and A2:

- Heating circuit pump for the heating circuit without mixer
- Circulation pump for cylinder heating
- DHW circulation pump

Function assignment

Function	Code ("General" group)	
	Output A1	Output A2
DHW circulation pump 28	33:0	34:0 (delivered condition)
Heating circuit pump 20	33:1 (delivered condition)	34:1
Circulation pump for cylinder heating 21	33:2	34:2

External extensions (accessories) (cont.)

Extension EA1

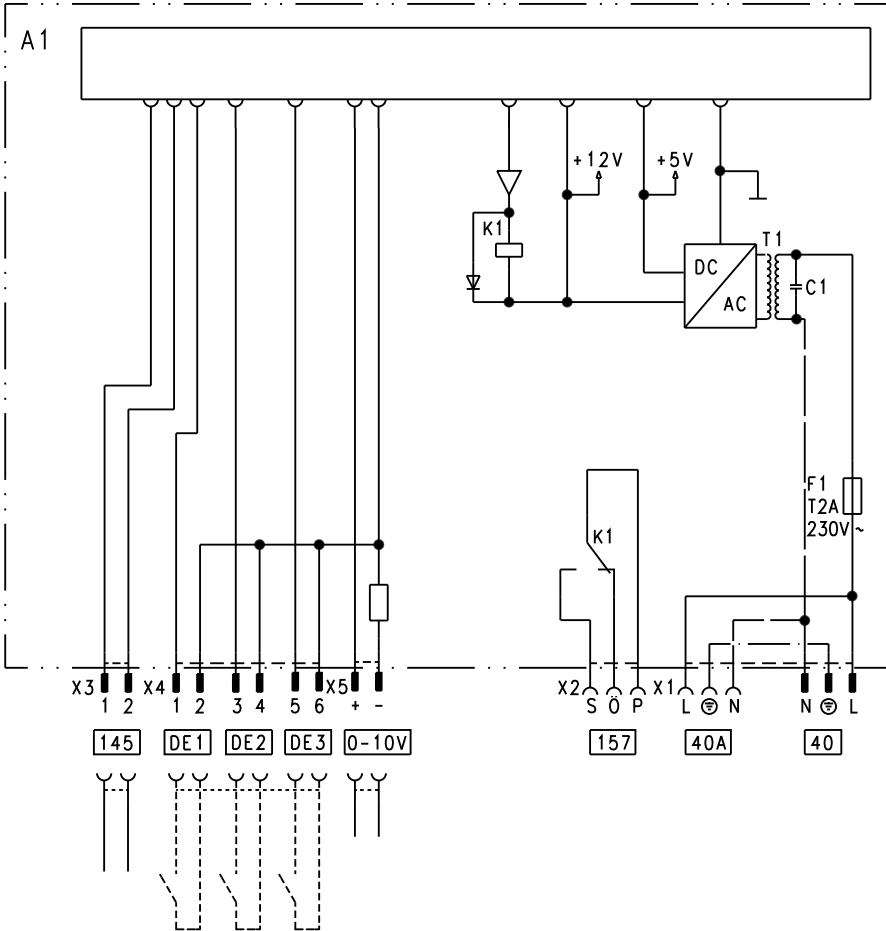

- A1 PCB
- F1 Fuse/MCB
- DE1 Digital input 1
- DE2 Digital input 2
- DE3 Digital input 3
- 0 – 10 V 0 – 10 V input
- 40 Power supply

- 40 A Power supply for additional accessories
- 157 Central fault message/feed pump/DHW circulation pump (potential-free)
- 145 KM BUS

External extensions (accessories) (cont.)

Digital data inputs DE1 to DE3

The following functions can be connected alternatively:

- External operating program changeover for each heating circuit
- External blocking
- External blocking with fault message input
- External demand with minimum boiler water temperature
- Fault message input
- Brief operation of the DHW circulation pump

External contacts must be floating. When connecting external contacts, observe the requirements of safety category II, i.e. 8.0 mm air and creep path or 2.0 mm insulation thickness to 'live' parts.

Input function assignment

Select the input functions by means of codes in the **"General"** group at the boiler control unit:

- DE1: Coding address 3A
- DE2: Coding address 3b
- DE3: Coding address 3C

Assigning the operating program changeover function to the heating circuits

Assign the operating program changeover function for the relevant heating circuit via coding address d8 in group **"Heating circuit"** at the boiler control unit:

- Changeover via input DE1: Code d8:1
- Changeover via input DE2: Code d8:2
- Changeover via input DE3: Code d8:3

The effect of the operating program changeover is selected via coding address d5 in the **"Heating circuit"** group.

The duration of the changeover is set via coding address F2 in the **"Heating circuit"** group.

Effect of the external blocking function on the pumps

The effect on the internal circulation pump is selected in coding address 3E in the **"General"** group.

The effect on the respective heating circuit pump is selected in coding address d6 in the **"Heating circuit"** group.

The effect on a circulation pump for cylinder heating is selected in coding address 5E in the **"DHW"** group.

Effect of the external demand function on the pumps

The effect on the internal circulation pump is selected in coding address 3F in the **"General"** group.

The effect on the respective heating circuit pump is selected in coding address d7 in the **"Heating circuit"** group.

The effect on a circulation pump for cylinder heating is selected in coding address 5F in the **"DHW"** group.

DHW circulation pump runtime for brief operation

The DHW circulation pump is started by closing the contact at DE1, DE2 or DE3 by means of a pushbutton. The runtime is adjusted via coding address "3d" in the **"General"** group.

External extensions (accessories) (cont.)

Analogue input 0 – 10 V

The 0 – 10 V hook-up provides an additional set boiler water temperature:

0 – 1 V is taken as "no default for set boiler water temperature".

1 V \triangleq Set value 10 °C

10 V \triangleq Set value 100 °C

Ensure DC separation between the earth conductor and the negative pole of the on-site voltage source.

Output 157

The following functions can be connected to output 157:

- Feed pump to substation
or
- DHW circulation pump
or
- Fault message facility

Function assignment

Select the function of output 157 via coding address "36" in the **"General"** group at the boiler control unit.

Control functions

External heating program changeover

The "External heating program changeover" function is connected via extension EA1. There are 3 inputs available at extension EA1 (DE1 to DE3).

The function is selected via the following coding addresses in the **"General"** group:

Heating program - changeover	Code
Input DE1	3A:1
Input DE2	3b:1
Input DE3	3C:1

Assign the operating program changeover function for the relevant heating circuit via coding address "d8" in group **"Heating circuit"** at the boiler control unit:

Heating program - changeover	Code
Changeover via input DE1	d8:1
Changeover via input DE2	d8:2
Changeover via input DE3	d8:3

Control functions (cont.)

You can select which direction the heating program changeover takes in coding address "d5" in the **"Heating circuit"** group:

Heating program - changeover	Code
Changeover towards "Permanently reduced" or "Permanent standby" mode (subject to the selected set value)	d5:0
Changeover towards "Constant heating mode"	d5:1

The duration of the heating program changeover is set via coding address "F2" in the **"Heating circuit"** group:

Heating program - changeover	Code
No operating program changeover	F2:0
Duration of the operating program changeover 1 to 12 hours	F2:1 to F2:12

The operating program changeover stays enabled for as long as the contact remains closed, but at least as long as the duration selected in coding address "F2".

External blocking

The "External blocking" and "External blocking and fault message input" functions are connected via extension EA1. There are 3 inputs available at extension EA1 (DE1 to DE3).

The function is selected via the following coding addresses in the **"General"** group:

External blocking	Code
Input DE1	3A:3
Input DE2	3b:3
Input DE3	3C:3

Control functions (cont.)

External blocking and fault message input	Code
Input DE1	3A:4
Input DE2	3b:4
Input DE3	3C:4

The effect on the internal circulation pump is selected in coding address "3E" in group **"General"**.

The effect on the relevant heating circuit pump is selected in coding address "d6" in group **"Heating circuit"**.

External demand

The "External demand" function is connected via extension EA1. There are 3 inputs available at extension EA1 (DE1 to DE3).

The function is selected via the following coding addresses in the **"General"** group:

External demand	Code
Input DE1	3A:2
Input DE2	3b:2
Input DE3	3C:2

The effect on the internal circulation pump is selected in coding address "3F" in group **"General"**.

The effect on the relevant heating circuit pump is selected in coding address "d7" in group **"Heating circuit"**.

The minimum set boiler water temperature in case of external demand is selected in coding address "9b" in group **"General"**.

Venting program

During the venting program, the circulation pump will be alternately switched on and off for 30 s at a time over a period of 20 min.

For a certain period, the diverter valve is alternately set towards heating and DHW heating. The burner is switched off during the venting program.

Activate venting program: See "Venting the heating system".

Control functions (cont.)

Fill program

In the delivered condition, the diverter valve is set to its central position, enabling the system to be filled completely. After the control unit has been switched on, the diverter valve no longer goes into its central position.

Afterwards, the diverter valve can be moved via the fill function into the central position (see "Filling the heating system"). In this position, the control unit can be switched off, and the system can be filled completely.

Filling with the control unit switched on

If the system is to be filled with the control unit switched on, the diverter valve is moved in the fill program to its central position and the pump starts.

When the function is enabled, the burner shuts down. The program is automatically disabled after 20 min.

Screed drying

When activating screed drying, observe the information provided by the screed manufacturer.

When the screed drying function is activated, the heating circuit pump in the heating circuit with mixer is switched on and the flow temperature is held in accordance with the selected profile. On completion (30 days), the heating circuit with mixer is regulated automatically via the set parameters.

Observe EN 1264. The report to be provided by the heating contractor must contain the following heat-up details:

- Heat-up data with respective flow temperatures
- Max. flow temperature achieved
- Operating state and outside temperature during handover

The various temperature profiles can be set via coding address "F1" in the "Heating circuit" group.

The function continues after power failure or after the control unit has been switched off. "Heating and DHW" is started when screed drying is finished or if code "F1:0" is set manually.

Temperature profile 1: (EN 1264-4) code "F1:1"

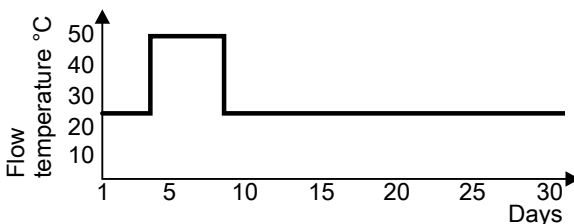

Control functions (cont.)

Temperature profile 2: (ZV parquet and flooring technology) code "F1:2"

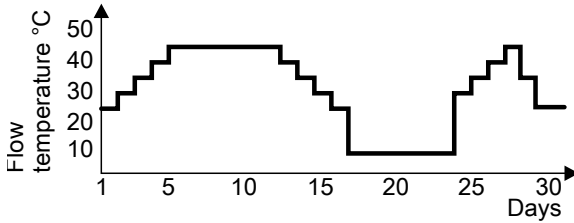

Temperature profile 3: Code "F1:3"

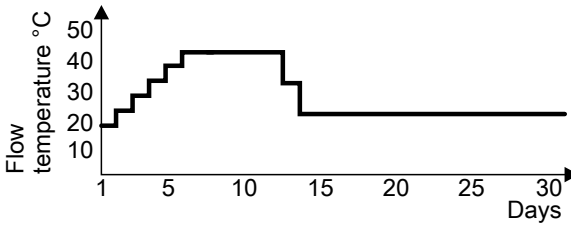

Temperature profile 4: Code "F1:4"

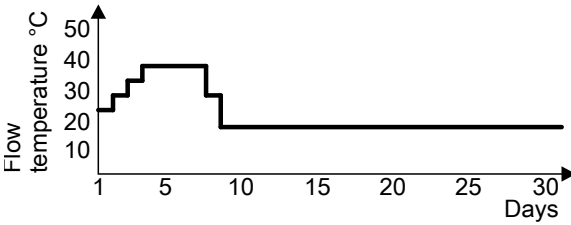

Temperature profile 5: Code "F1:5"

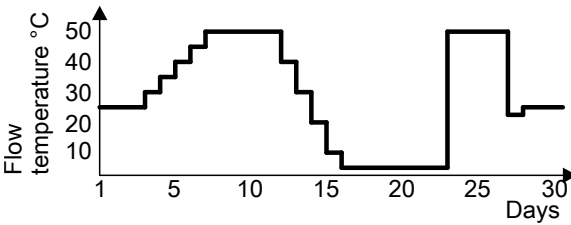

Control functions (cont.)

Temperature profile 6: Code "F1:6"

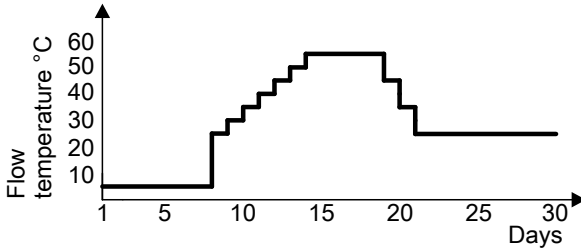

Temperature profile 7: Code "F1:15"

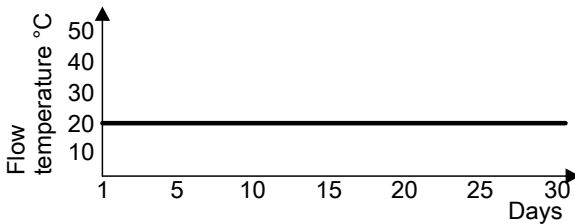

Raising the reduced room temperature

During operation with reduced room temperature, the reduced set room temperature can be automatically raised subject to the outside temperature. The temperature is raised in accordance with the selected heating curve, but no higher than the set standard room temperature.

The outside temperature limits for the start and end of temperature raising can be set in coding addresses "F8" and "F9" in the **"Heating circuit"** group.

Control functions (cont.)

Example using the settings in the delivered condition

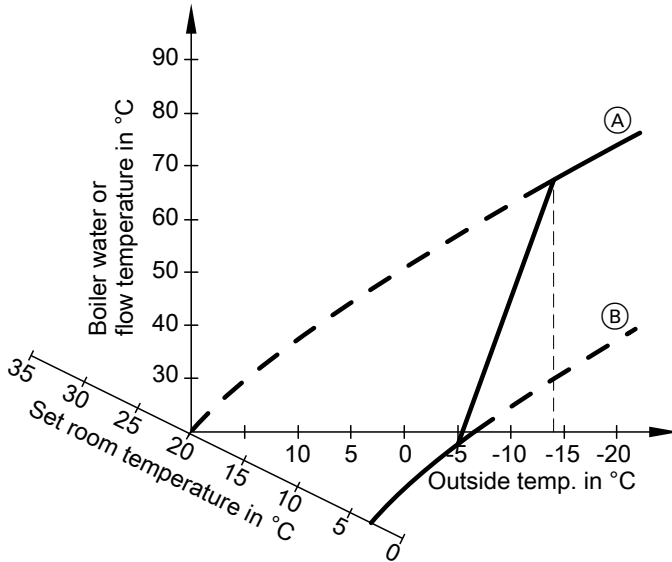

(A) Heating curve for operation with standard room temperature

(B) Heating curve for operation with reduced room temperature

Reducing the heat-up time

During the transition from operation with reduced room temperature to operation with standard room temperature, the boiler water or flow temperature will be raised in accordance with the selected heating curve. The boiler water or flow temperature can be automatically increased.

The value and duration of the additional increase in the set boiler water or flow temperature can be set in coding addresses "FA" and "Fb" in the **"Heating circuit"** group.

Control functions (cont.)

Example using the settings in the delivered condition

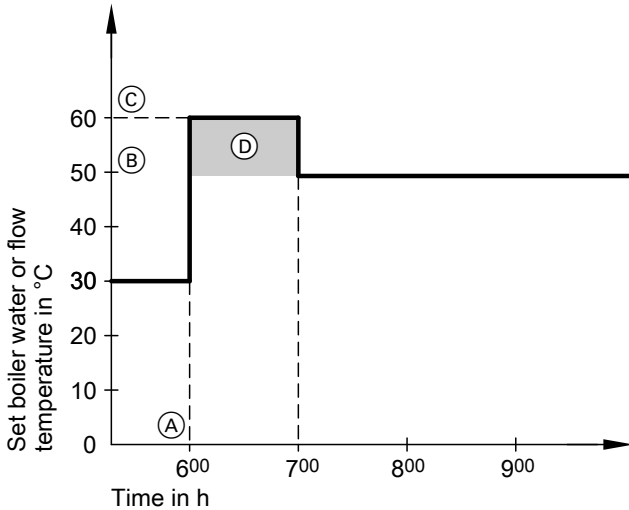

- Ⓐ Start of operation with standard room temperature
- Ⓑ Set boiler water or flow temperature in accordance with the selected heating curve
- Ⓒ Set boiler water or flow temperature in accordance with coding address "FA":
 $50\text{ °C} + 20\% = 60\text{ °C}$
- Ⓓ Duration of operation with raised set boiler water or flow temperature in accordance with coding address "Fb":
 60 min

Allocating heating circuits to the remote control

The heating circuit allocation must be configured when commissioning the Vitotrol.

Heating circuit	Vitotrol configuration	
	200A/200 RF	300A/300 RF
The remote control affects the heating circuit without mixer A1	H 1	HC 1
The remote control affects the heating circuit with mixer M2	H 2	HC 2
The remote control affects the heating circuit with mixer M3	H 3	HC 3

Note

One heating circuit can be assigned to the Vitotrol 200A/200 RF.

Up to three heating circuits can be assigned to the Vitotrol 300A/300 RF.

Up to 2 remote controls may be connected to the control unit.

If the heating circuit allocation is later cancelled, reset coding address A0 for this heating circuit to 0 (fault message bC, bd, bE).

Electronic combustion control unit

The electronic combustion controller utilises the physical correlation between the level of the ionisation current and the air ratio λ . The maximum ionisation current is achieved at an air ratio of 1 for all gas qualities.

The ionisation signal is evaluated by the combustion controller and the air ratio is adjusted to a value between $\lambda=1.24$ and 1.44. This range provides for an optimum combustion quality. Thereafter, the electronic gas valve regulates the required gas volume subject to the prevailing gas quality.

To check the combustion quality, the CO₂ content or the O₂ content of the flue gas is measured. The prevailing air ratio is determined with the measured values. The relationship between the CO₂ or O₂ content and air ratio λ is illustrated in the following table.

Electronic combustion control unit (cont.)**Air ratio λ – CO₂/O₂ content**

Air ratio λ	O ₂ content (%)	CO ₂ content (%) for natural gas E	CO ₂ content (%) for natural gas LL	CO ₂ content (%) for LPG P
1.20	3.8	9.6	9.2	11.3
1.24	4.4	9.2	9.1	10.9
1.27	4.9	9.0	8.9	10.6
1.30	5.3	8.7	8.6	10.3
1.34	5.7	8.5	8.4	10.0
1.37	6.1	8.3	8.2	9.8
1.40	6.5	8.1	8.0	9.6
1.44	6.9	7.8	7.7	9.3
1.48	7.3	7.6	7.5	9.0

For optimum combustion control, the system regularly carries out an automatic self-calibration; also after a power failure (shutdown). For this, the combustion is briefly regulated to max. ionisation current (corresponding to air ratio $\lambda=1$). Automatic calibration is carried out shortly after the burner start and lasts approx. 5 s. During calibration, higher than normal CO emissions may occur briefly.

Internal connection diagram

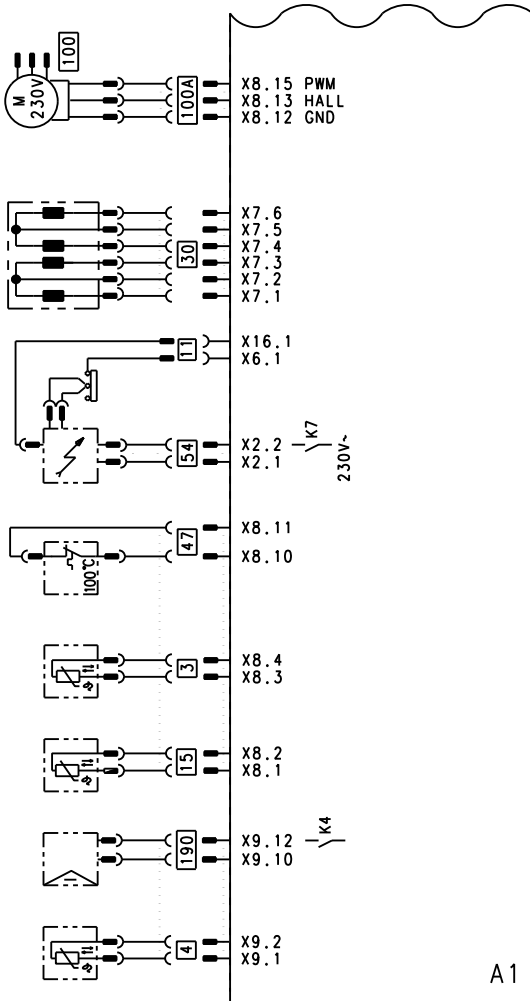

- | | | | |
|------|---------------------------------|------|----------------------------------|
| A1 | Main PCB | 30 | Stepper motor for diverter valve |
| X... | Electrical interfaces | 47 | Temperature limiter |
| 3 | Boiler water temperature sensor | 54 | Ignition unit |
| 4 | Outlet temperature sensor | 100 | Fan motor |
| 11 | Ionisation electrode | 100A | Fan motor control |
| 15 | Flue gas temperature sensor | 190 | Modulation coil |

External connection diagram

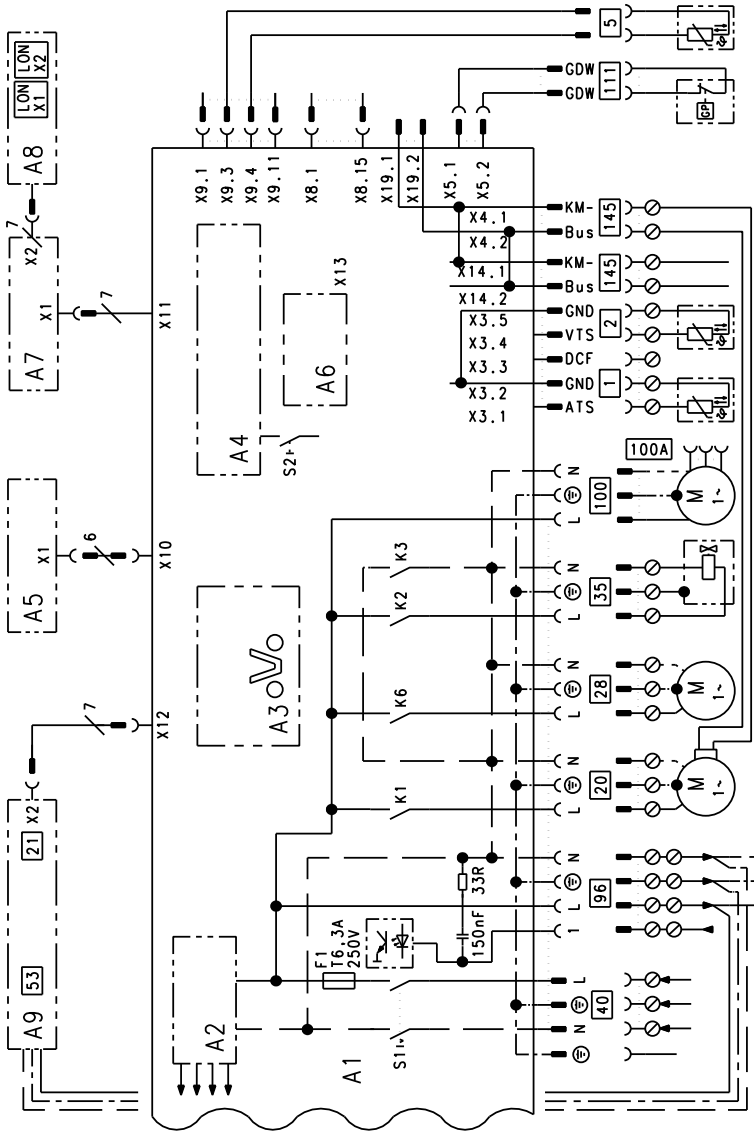

- | | | | |
|----|-------------------|----|---------------------|
| A1 | Main PCB | A4 | Burner control unit |
| A2 | Power supply unit | A5 | Programming unit |
| A3 | Optolink | A6 | Coding card |



External connection diagram (cont.)

A7	Connection adaptor	20	Internal circulation pump
A8	LON communication module (accessories)	28	Cylinder primary pump
A9	Internal extension H1 or H2 (accessories)	35	Gas solenoid valve
S1	ON/OFF switch	40	Power supply
S2	Reset button	96	Power supply for accessories and Vitotrol 100
X...	Electrical interfaces	100	Fan motor
1	Outside temperature sensor	100 A	Fan motor control
2	Flow temperature sensor, low loss header	111	Gas pressure switch
5	Cylinder temperature sensor (plug on the cable harness)	145	KM BUS

Ordering individual parts

The following information is required:

- Serial no. (see type plate (A))
- Assembly (from this parts list)
- Position number of the individual part within the assembly (from this parts list)

Standard parts are available from your local dealer.

Overview of the assemblies

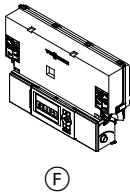
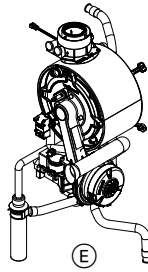
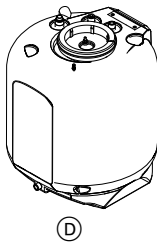
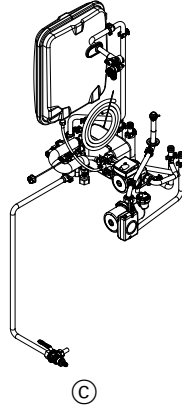
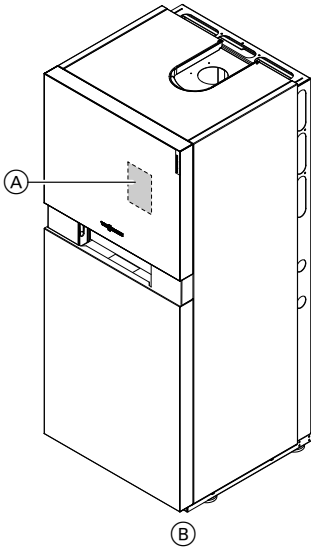

- (A) Type plate
- (B) Casing assembly

- (C) Hydraulic assembly with hydraulic block
- (D) Primary store assembly

Overview of the assemblies (cont.)

- | | |
|--|---|
| <ul style="list-style-type: none"> Ⓔ Heat cell assembly with MatriX cylinder burner | <ul style="list-style-type: none"> Ⓕ Control unit assembly Ⓖ Miscellaneous assemblies |
|--|---|

Casing

- | | |
|--|---|
| <ul style="list-style-type: none"> 0001 Front panel, top 0002 Logo 0003 Toggle fastener (set) 0004 Cover panel with profiled seal 0005 Profiled seal 0006 Adjustable foot 0007 Control unit support | <ul style="list-style-type: none"> 0008 Side panel, right 0009 Side panel, left 0010 Primary store mounting bracket 0011 Top panel insert 0012 Top panel 0013 Front panel, bottom 0014 Location stud fixings (2 pce) |
|--|---|

Casing (cont.)

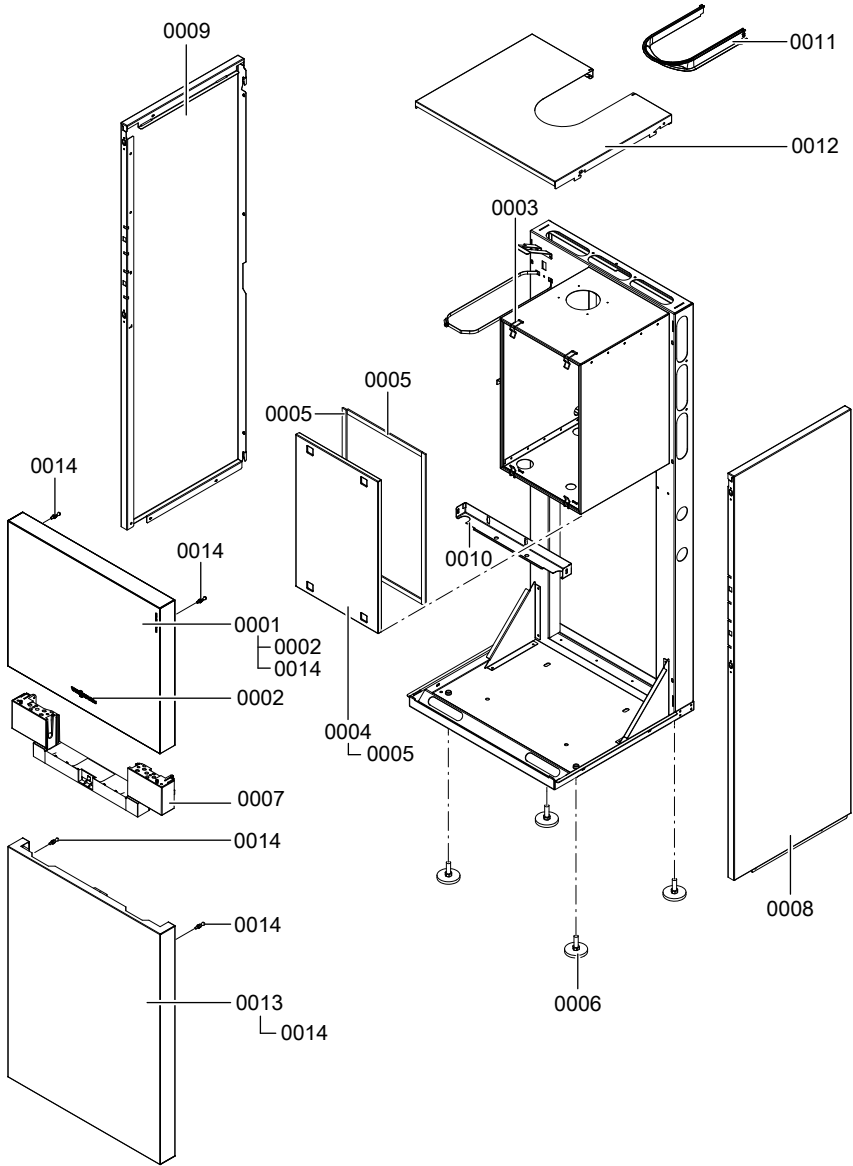

Hydraulics

- | | | | |
|------|--|------|--|
| 0001 | Hydraulic block | 0026 | Round sealing ring 8 x 2 (5 pce) |
| 0002 | Set of plug-in connector retainers (2 pce) | 0027 | Connection line, DHW charging |
| 0003 | Diaphragm grommet (5 pce) | 0028 | Shut-off valve, DHW, cylinder |
| 0004 | Diaphragm grommet (5 pce) | 0029 | Flow pipe |
| 0005 | Clip Ø 8 (5 pce) | 0030 | Expansion vessel |
| 0006 | Clip Ø 10 (5 pce) | 0031 | Connection pipe, cold water |
| 0007 | Clip Ø 15 (5 pce) | 0032 | Heating water return connection pipework |
| 0008 | Clip Ø 18 (5 pce) | 0033 | Thermal circuit breaker |
| 0009 | Air vent valve G3/8 | 0034 | Hose 10 x 1.5 x 1500 |
| 0010 | Spring clip (5 pce) | 0035 | Pressure gauge |
| 0011 | Connection pipe HR | 0036 | Safety valve |
| 0012 | Pipe clip Ø 18 / 1.5 | 0037 | Connection pipe, heating water flow, heat cell |
| 0013 | Fascia | 0038 | Air vent valve |
| | ■ 13-19 kW Ø 4.0 (white) | 0039 | Circulation pump motor |
| | ■ 26 kW Ø 5.5 (dark grey) | 0040 | CIAO casing |
| | ■ 35 kW Ø 6.0 (beige) | 0041 | Gasket A 17 x 24 x 2 (5 pce) |
| 0014 | Pipe clip Ø 18 | 0042 | Gasket 23 x 30 x 2, green (5 pce) |
| 0015 | Union nut G1 | 0043 | Temperature sensor |
| 0016 | Sleeve | 0044 | Gasket A 16 x 24 x 2 (5 pce) |
| 0017 | Heating water flow connection pipe | 0045 | Cap G 3/4 SW 30 |
| 0018 | DHW connection pipe | 0046 | Gasket A 10 x 15 x 1.5 (5 pce) |
| 0019 | Connection pipe, cold water, cylinder | 0047 | O-ring 17.86 x 2.62 (5 pce) |
| 0020 | Expansion vessel connection line G 3/8 | 0048 | O-ring 14.3 x 2.4 |
| 0021 | Cold water hydraulic connection | 0049 | Spring clip DN 25 (5 pce) |
| 0022 | Pump motor | 0050 | Plug |
| 0023 | CIL casing | 0051 | Gasket A 23 x 30 x 2, orange (5 pce) |
| 0024 | Cartridge non-return valve | | |
| 0025 | Shut-off valve, cold water, cylinder | | |

Hydraulics (cont.)

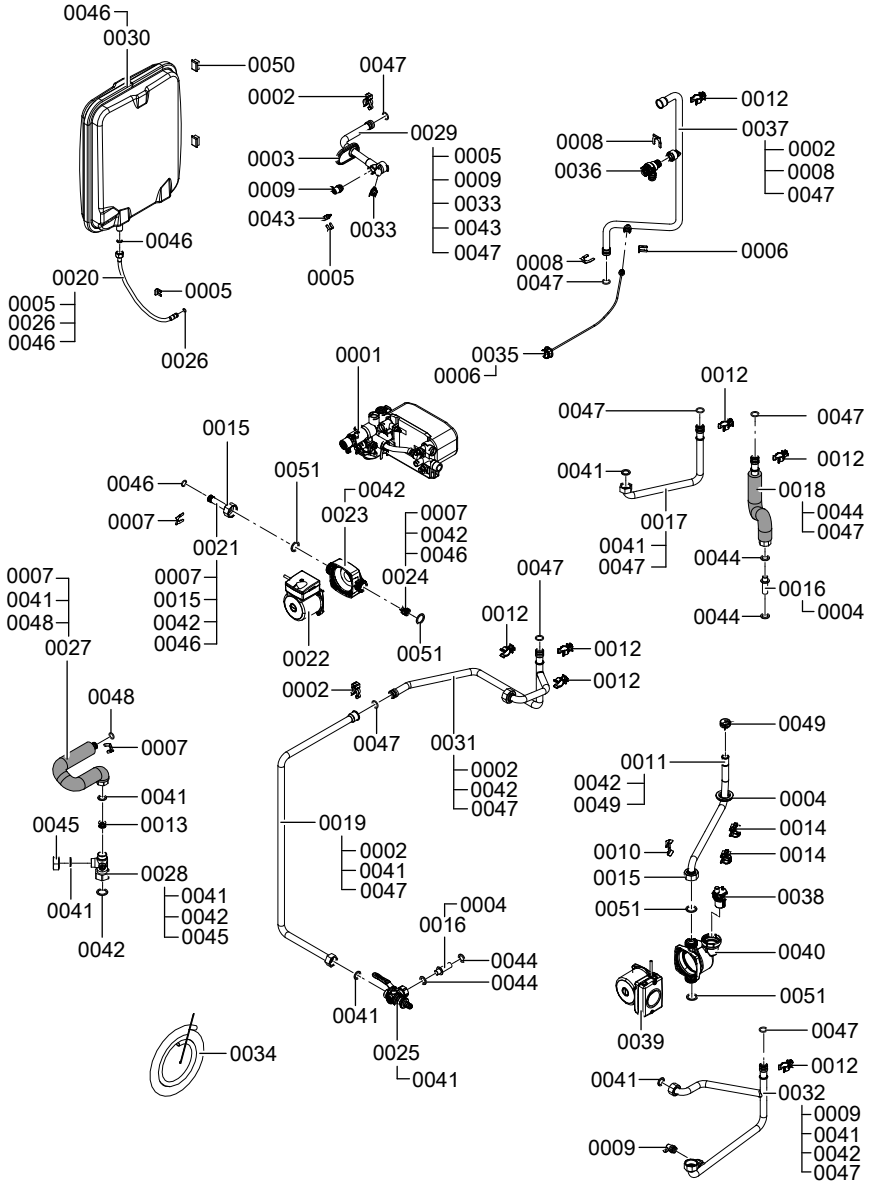

Hydraulics (cont.)**Hydraulic block**

0001	Return unit	0010	Overflow pipe
0002	Profiled gasket	0011	Flow unit
0003	Plug Ø 8/Ø 10	0012	Valve insert
0004	Clip Ø 8 (5 pce)	0013	Overflow valve
0005	Clip Ø 10 (5 pce)	0014	O-ring 17.86 x 2.62 (5 pce)
0006	Clip Ø 18 (5 pce)	0015	Gasket A 17 x 24 x 2 (5 pce)
0007	Hydraulic retaining bracket	0016	O-ring 9.6 x 2.4 (5 pce)
0008	Plate heat exchanger insulation board	0017	Temperature sensor
0009	Plate heat exchanger insulation shell	0018	Plate heat exchanger

Hydraulics (cont.)

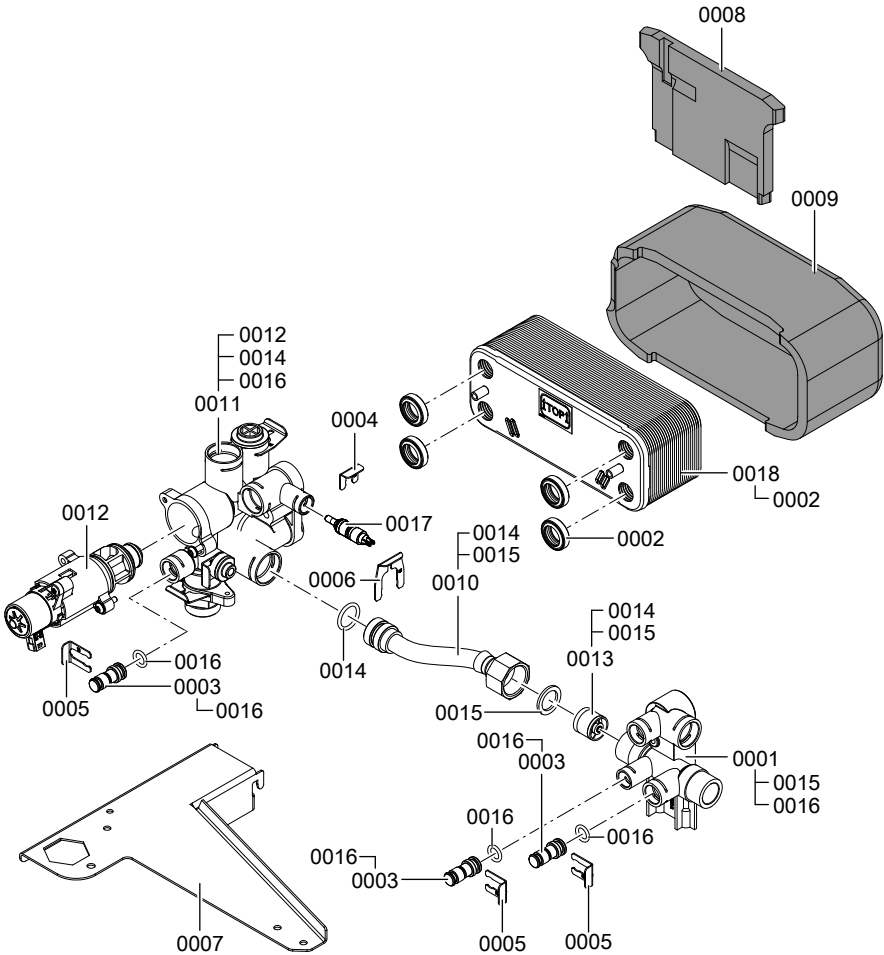

Primary store

- | | | | |
|------|--------------------|------|----------------------------|
| 0001 | Primary store | 0006 | Cover |
| 0002 | Strain relief | 0007 | Gasket 23 x 30 x 2 (5 pce) |
| 0003 | Magnesium anode | 0008 | Sleeve |
| 0004 | Gasket | | |
| 0005 | Flange with gasket | | |

Primary store (cont.)

- 0009 Flange insulation
- 0010 Cylinder temperature sensor
NTC 10k Ω

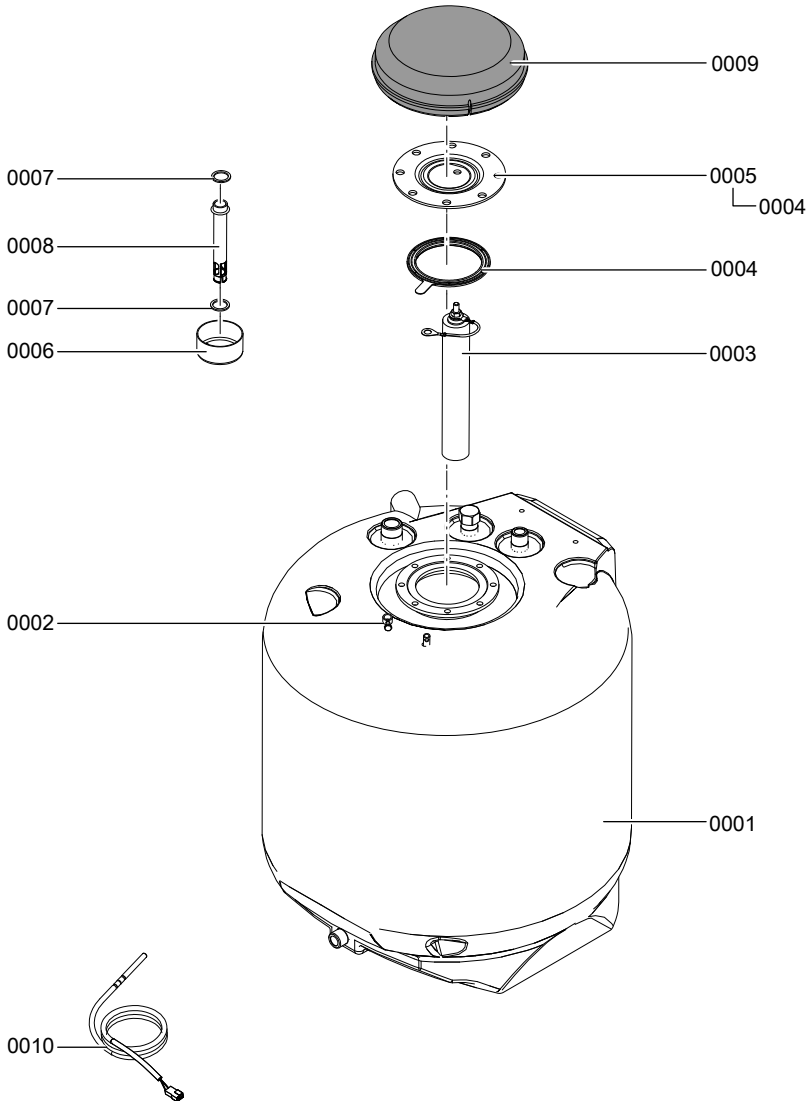

5773 216 GB

Heat cell

0001	MatriX cylinder burner	0014	O-rings 35.4 x 3.59 (5 pce)
0002	Locking clip, condensate drain	0015	Gasket A 17 x 24 x 2 (5 pce)
0003	Profile hose, heating return	0016	Hose 19 x 600, corrugated
0004	Condensate collector	0017	Spring clip DN 25 (5 pce)
0005	Flue gasket	0018	Hose 19 x 270, corrugated
0006	Siphon	0019	Hose 19 x 500, corrugated
0007	Condensate hose	0020	Boiler flue connection plug
0008	Pipe clip Ø 18 / 1.5	0021	Gasket DN 60
0009	Flue gas temperature sensor	0022	Diaphragm grommet (5 pce)
0010	Boiler flue connection	0023	Heating water return connection elbow
0011	Heat exchanger	0024	Thermal insulation block
0012	Gas pipe	0025	O-ring 63 x 2.62 (5 pce)
0013	Condensate hose		

Heat cell (cont.)

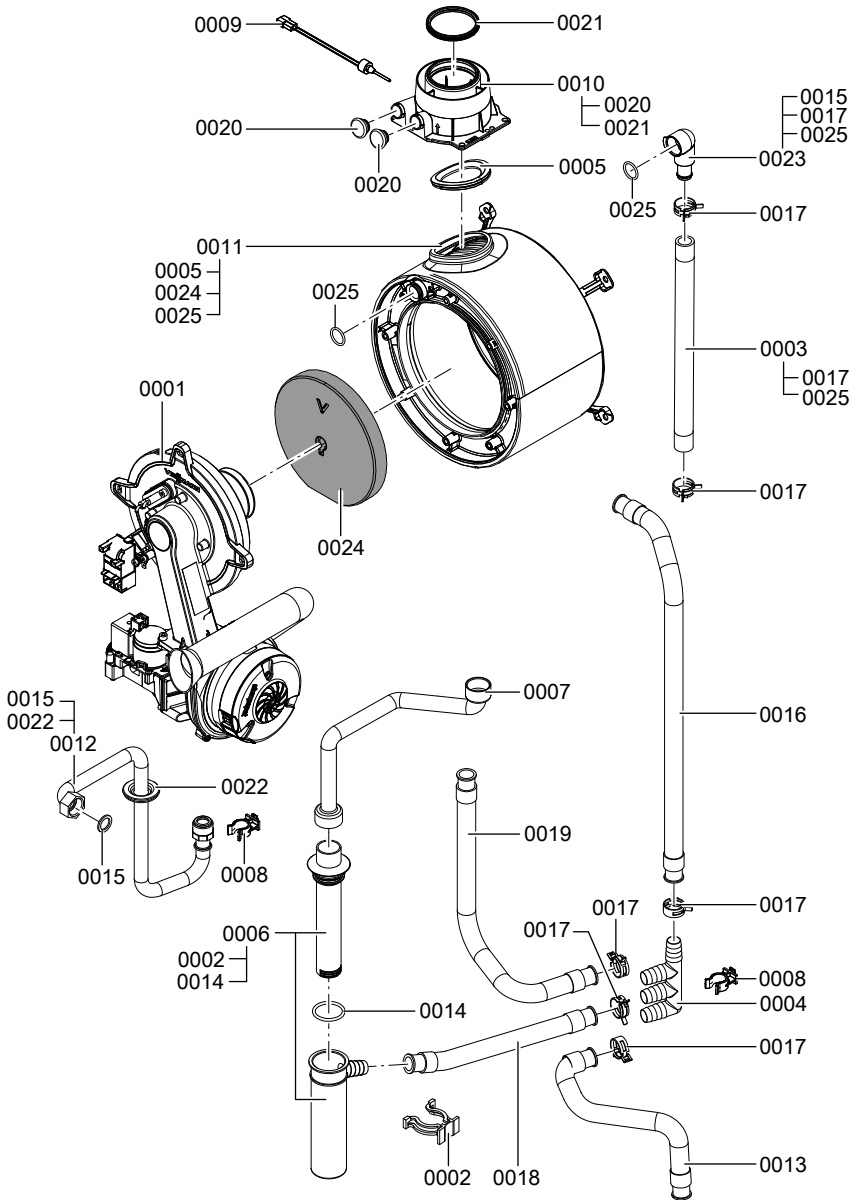

Heat cell (cont.)

MatriX cylinder burner

0001	Burner gasket (wearing part)	0012	Ionisation electrode gasket (5 pce)
0002	Thermal insulation ring	0013	Ignition electrode gasket (5 pce)
0003	Cylinder burner gauze assembly	0014	Blade terminal (10 pce)
0004	Burner gauze assembly gasket	0015	Mixture restrictor
0005	Ignition electrode (wearing part)	0016	Gas nozzle
0006	Ionisation electrode (wearing part)	■ 13 kW/19 kW: 02 yellow	
0007	Gasket, burner door flange (wearing part)	■ 26 kW: 04 grey	
0008	Radial fan	■ 35 kW: 06 black	
0009	Gas train	0017	Venturi extension
0010	Burner door	0018	Mounting plate, thermal insulation ring (2 pce)
0011	Ignition unit	0019	Gasket DN 65

Heat cell (cont.)

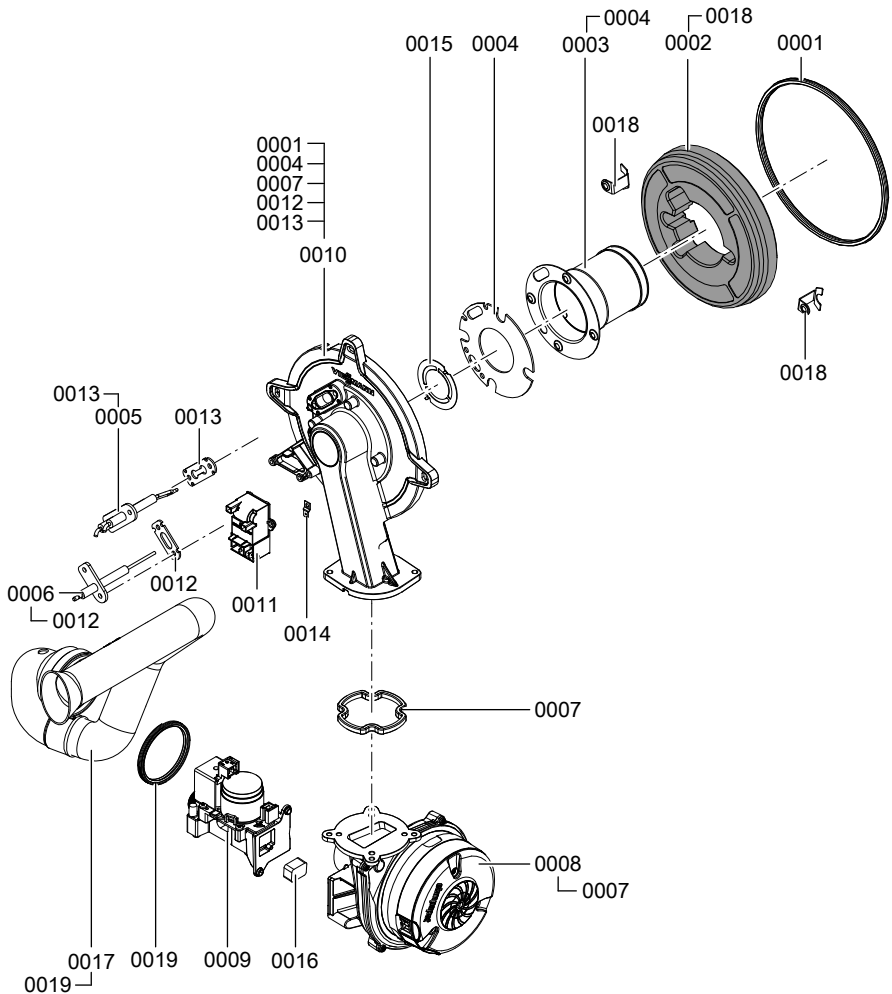

Control unit

- | | | | |
|------|--------------------------------|------|--|
| 0001 | Control unit | 0005 | Fuse holder |
| 0002 | Control unit casing back panel | 0006 | Programming unit for constant temperature mode |
| 0003 | Coding card | | |
| 0004 | Fuse 6.3 A (slow) (10 pce) | | |



Control unit (cont.)

0007	Programming unit for weather-compensated mode	0015	Locking bolts, left and right
0008	LON module	0017	Wireless outside temperature sensor
0009	PCB adaptor	0018	Outside temperature sensor (hardwired)
0010	Cable harness X8/X9/ionisation	0019	KM BUS cable 145
0011	Cable harness 100/35/54/PE	0020	Internal extension H1
0012	Power cable, stepper motor	0021	Internal extension H2
0013	Mating plug (set)		
0014	Cable fixing		

Control unit (cont.)

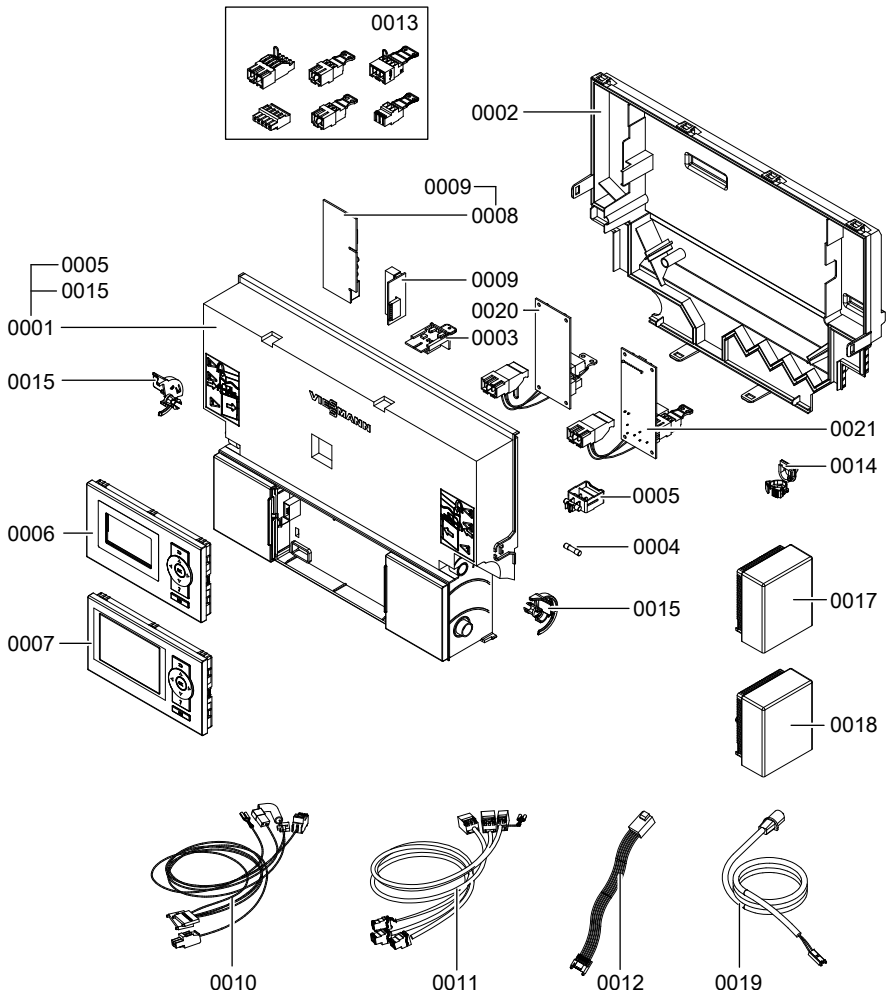

Miscellaneous

- 0001 Special grease
- 0002 Spray paint, Vitowhite
- 0003 Touch-up paint stick, Vitowhite

- 0004 Installation and service instructions

Miscellaneous (cont.)

0005 Operating instructions for constant temperature mode

0006 Operating instructions for weather-compensated mode

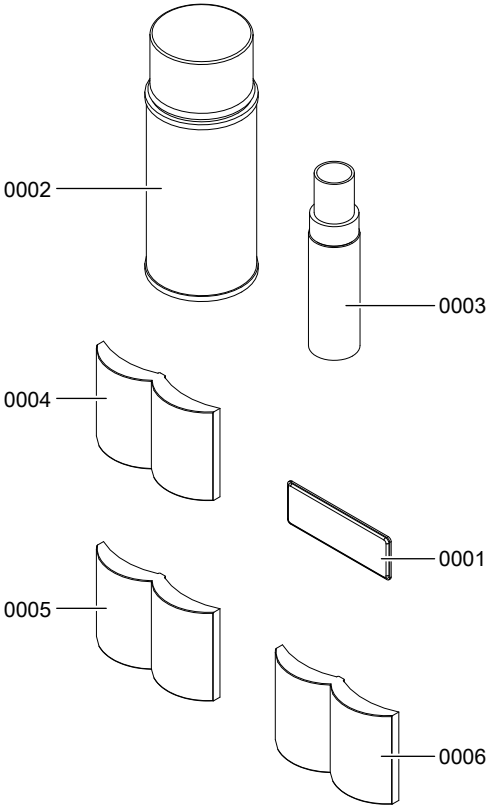

Commissioning/service reports

Settings and actual values	Set value	Commis- sioning	Mainte- nance/ Service
Date			
Signature			
Static pressure	<i>mbar</i> ≤ 57.5 <i>kPa</i> ≤ 5.75		
Supply pressure (flow pres- sure)			
<input type="checkbox"/> for natural gas E	<i>mbar</i> 17.4-25 <i>kPa</i> 1.74-2.5		
<input type="checkbox"/> for natural gas LL	<i>mbar</i> 17.4-25 <i>kPa</i> 1.74-2.5		
<input type="checkbox"/> for LPG	<i>mbar</i> 42.5-57.5 <i>kPa</i> 4.25-5.75		
<i>Tick gas type</i>			
Carbon dioxide content			
CO₂			
For natural gas			
■ At lower heating output	<i>% by vol.</i> 7.5-9.5		
■ At upper heating output	<i>% by vol.</i> 7.5-9.5		
For LPG			
■ At lower heating output	<i>% by vol.</i> 8.8-11.1		
■ At upper heating output	<i>% by vol.</i> 8.8-11.1		
Oxygen content O₂			
■ At lower heating output	<i>% by vol.</i> 4.0-7.6		
■ At upper heating output	<i>% by vol.</i> 4.0-7.6		
Carbon monoxide content			
CO			
■ At lower heating output	<i>ppm</i> < 1000		
■ At upper heating output	<i>ppm</i> < 1000		

Specification

Specification

Rated voltage	230 V	Electronic temperature limiter setting	81 °C
Rated frequency	50 Hz	Temperature limiter setting	100 °C (fixed)
Rated current	6 A	Backup fuse (power supply)	Max. 16 A
Safety category	I		
IP rating	IP X 4 D to EN 60529		
Permissible ambient temperature			
■ During operation	0 to +40 °C		
■ During storage and transport	-20 to +65 °C		

Rated heating output range

at T_V/T_R 50/30 °C	kW	3.2 (4.8) ^{*2} - 13	3.2 (4.8) ^{*2} - 19	5.2 (8.8) ^{*2} - 26	5.2 (8.8) ^{*2} - 35
at T_V/T_R 80/60 °C	kW	2.9 (4.3) ^{*2} - 11.8	2.9 (4.3) ^{*2} - 17.2	4.7 (8.0) ^{*2} - 23.7	4.7 (8.0) ^{*2} - 31.7
for DHW heating	kW	2.9 (4.3) ^{*2} - 17.2	2.9 (4.3) ^{*2} - 17.2	4.7 (8.0) ^{*2} - 29.3	4.7 (8.0) ^{*2} - 33.5

Rated heat input range

	kW	3.1 (4.5) ^{*2} - 17.9	3.1 (4.5) ^{*2} - 17.9	4.9 (8.3) ^{*2} - 30.5	4.9 (8.3) ^{*2} - 34.9
--	----	-----------------------------------	-----------------------------------	-----------------------------------	-----------------------------------

Power consumption

In the delivered condition	W	39	53	68	89
Maximum	W	102	105	154	166

Supply values relative to the max. load

Natural gas E	m ³ /h	1.89	1.89	3.23	3.69
Natural gas LL	m ³ /h	2.20	2.20	3.75	4.30
LPG P	kg/h	1.40	1.40	2.38	2.73

Product ID

CE-0085CN0050

^{*2} Only when operating with LPG P

Specification (cont.)**Note**

The connection values are only for documentation purposes (e.g. in the gas contract application) or to estimate a supplementary volumetric settings check. Due to the factory settings, the gas pressure must not be altered from these values. Reference: 15 °C, 1013 mbar (101.3 kPa).

Declaration of conformity

We, Viessmann Werke GmbH&Co KG, D-35107 Allendorf, declare as sole responsible body that the product **Vitodens 222-F, type B2TA** complies with the following standards:

DIN 4753	EN 55 014
EN 483	EN 60 335-1
EN 625	EN 60 335-2-102
EN 677	EN 61 000-3-2
EN 806	EN 61 000-3-3
EN 12897	EN 62 233

In accordance with the following Directives, this product is designated with **CE-0085**:

97/23/EC	2006/95/EC
92/42/EEC	2009/142/EC
2004/108/EC	

This product meets the requirements of the Efficiency Directive (92/42/EEC) for **condensing boilers**.

Allendorf, 1 January 2013

Viessmann Werke GmbH&Co KG



Authorised signatory Manfred Sommer

Manufacturer's certificate according to the 1st BImSchV [Germany]

We, Viessmann Werke GmbH&Co KG, D-35107 Allendorf, confirm that the product **Vitodens 222-F, type B2TA**, complies with the NO_x limits specified by the 1st BImSchV Paragraph 6 [Germany].

Allendorf, 1 January 2013

Viessmann Werke GmbH&Co KG

A handwritten signature in black ink, appearing to read 'M. Sommer', written in a cursive style.

Authorised signatory Manfred Sommer

Keyword index

A

Acknowledging a fault display.....	120
Actuator test.....	118
Anode, checking.....	60
Anode, replacing.....	60
Assembly.....	171

B

Boiler, draining on the DHW side.....	58
Boiler water temperature sensor.....	140
Boosting DHW heating.....	151
Brief scans.....	113
Burner gasket.....	51
Burner gauze assembly.....	51
Burner installation.....	52
Burner removal.....	50

C

Calling up fault messages.....	121
Calling up the service level.....	111
Calling up the service menu.....	111
Cleaning the heating surfaces.....	52, 55
Code 1	
■ Calling up.....	77
Code 2	
■ Calling up.....	89
Codes for commissioning.....	64
Combustion chamber, cleaning.....	52, 55
Combustion controller.....	166
Combustion quality, checking.....	63
Commissioning.....	35
Condensate drain.....	53
Connection diagrams.....	168
Control unit.....	149
Control unit maintenance position....	137
Cylinder cleaning.....	59
Cylinder temperature sensor.....	140

D

Date, setting.....	38
Diaphragm expansion vessel.....	36

E

Electronic combustion controller.....	166
Extension	
■ AM1.....	154
■ EA1.....	156
■ Internal H1.....	152
■ Internal H2.....	153
Extension kit for heating circuit with mixer	146
External blocking.....	159
External demand.....	160

F

Fault codes.....	122
Fault history.....	120
Fault manager.....	74
Fault memory.....	120, 121
Fault messages, calling up.....	120
Faults.....	120
Fill function.....	161
Fill water.....	35
Flow temperature sensor.....	140
Flue gas temperature sensor.....	144
Function descriptions.....	149
Function testing.....	118
Fuse.....	146

G

Gas supply pressure.....	45
Gas train	45
Gas type.....	43
Gas type conversion.....	44

H

Heating circuit allocation.....	166
Heating curve.....	70
Heating curve level.....	72
Heating curve slope.....	72
Heating output setting.....	48
Heating program changeover.....	158
Heat-up time.....	164

Keyword index (cont.)

- I**
 Ignition.....52
 Ignition electrodes.....52
 Ionisation electrode.....52
- L**
 Language selection.....37
 LON.....73
 ■ Fault monitoring.....74
 ■ Setting subscriber numbers.....73
 ■ Subscriber check.....74
 LON communication module.....73
- M**
 Magnesium anode, checking.....60
 Magnesium anode, replacing.....60
 Manufacturer's certificate191
 Mixer open/close.....147
- O**
 Operating conditions, scanning.....112
 Operating data, scanning.....112
 Outlet temperature sensor.....142
 Outside temperature sensor.....139
- P**
 Plate heat exchanger.....143
 Protective anode
 ■ Anode, checking.....56
 ■ Anode current, checking.....56
- R**
 Raising the reduced room temperature.....163
 Reduced set room temperature.....72
 Reducing the heat-up output.....163
 Reducing the heat-up time.....164
 Relay test.....118
 Remote control.....166
 Removing a fault display.....120
 Report.....187
 Rotational direction of mixer motor
 ■ Changing.....147
 ■ Checking.....147
- S**
 Safety chain145
 Screed drying.....161
 Screed drying function.....161
 Service scanning.....75
 Set room temperature selection.....71
 Siphon.....53
 Specification188
 Standard set room temperature.....72
 Static pressure.....45
 Supply pressure.....44
 System, filling.....36, 37
 System pressure.....36, 37
 System schemes.....64, 77
 System version.....65
- T**
 Temperature limiter.....145
 Tightness test, balanced flue system.49
 Time, setting.....38
- V**
 Venting.....39
 Venting program.....160
 Vitocom 200.....73
 Vitotronic 200-H.....73
 Vitotronic 200-H.....148
- W**
 Wiring diagram.....168





Applicability

Serial No.:

7519081

7513044

7513045

7513046

Viessmann Werke GmbH&Co KG
D-35107 Allendorf
Telephone: +49 6452 70-0
Fax: +49 6452 70-2780
www.viessmann.com

Viessmann Limited
Hortonwood 30, Telford
Shropshire, TF1 7YP, GB
Telephone: +44 1952 675000
Fax: +44 1952 675040
E-mail: info-uk@viessmann.com

5773 216 GB Subject to technical modifications.