

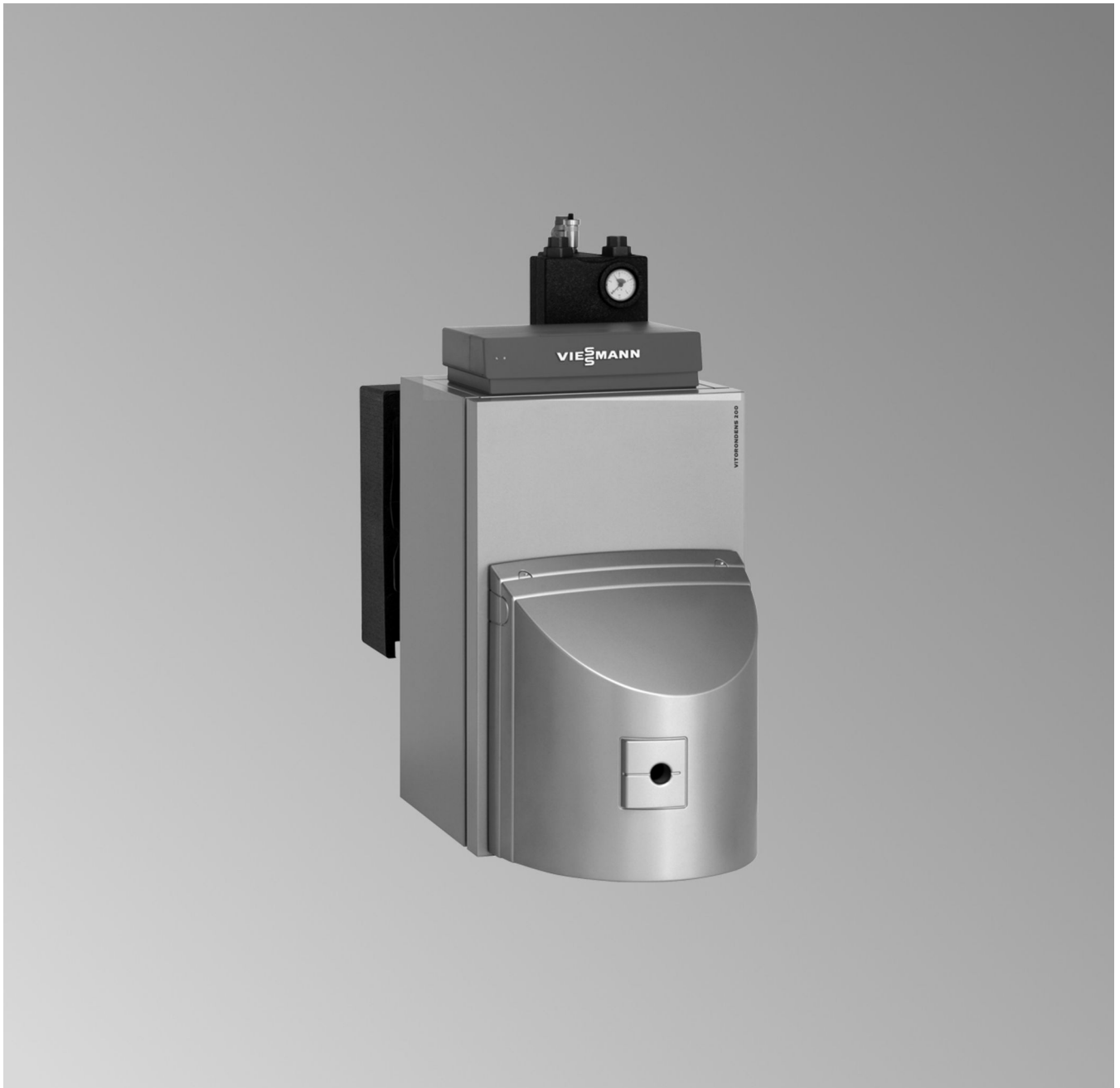

**Vitorondens 200-T**  
**Type BR2A**, 20.2 to 53.7 kW  
Oil Unit condensing boiler



## **VITORONDENS 200-T**



### Safety instructions

-  Please follow these safety instructions closely to prevent accidents and material losses.

### Safety instructions explained

-  **Danger**  
This symbol warns against the risk of injury.

-  **Please note**  
This symbol warns against the risk of material losses and environmental pollution.

**Note**  
*Details identified by the word "Note" contain additional information.*

### Target group

These instructions are exclusively intended for qualified contractors.

- Work on gas installations may only be carried out by a registered gas fitter.
- Work on electrical equipment may only be carried out by a qualified electrician.
- The system must be commissioned by the system installer or a qualified person authorised by the installer.

### Regulations to be observed

- National installation regulations
- Statutory regulations for the prevention of accidents
- Statutory regulations for environmental protection
- Codes of practice of the relevant trade associations
- Relevant country-specific safety regulations

### Safety instructions for working on the system

#### Working on the system

- Where gas is used as the fuel, close the main gas shut-off valve and safeguard it against unintentional reopening.
- Isolate the system from the power supply, e.g. by removing the separate fuse or by means of a mains isolator, and check that it is no longer live.
- Safeguard the system against reconnection.
- Wear suitable personal protective equipment when carrying out any work.

**Safety instructions** (cont.)**Danger**

Hot surfaces and fluids can lead to burns or scalding.

- Before maintenance and service work, switch OFF the appliance and let it cool down.
- Never touch hot surfaces on the boiler, burner, flue system or pipe-work.

**Please note**

Electronic assemblies can be damaged by electrostatic discharge. Prior to commencing work, touch earthed objects such as heating or water pipes to discharge static loads.

**Repair work****Please note**

Repairing components that fulfil a safety function can compromise the safe operation of the system. Replace faulty components only with genuine Viessmann spare parts.

**Auxiliary components, spare and wearing parts****Please note**

Spare and wearing parts that have not been tested together with the system can compromise its function. Installing non-authorised components and making non-approved modifications or conversions can compromise safety and may invalidate our warranty. For replacements, use only original spare parts supplied or approved by Viessmann.

## Safety instructions for operating the system

### If you smell gas

-  **Danger**  
Escaping gas can lead to explosions which may result in serious injury.
- Do not smoke. Prevent naked flames and sparks. Never switch lights or electrical appliances on or off.
  - Close the gas shut-off valve.
  - Open windows and doors.
  - Evacuate any people from the danger zone.
  - Notify your gas or electricity supply utility from outside the building.
  - Have the power supply to the building shut off from a safe place (outside the building).

### If you smell flue gas

-  **Danger**  
Flue gas can lead to life threatening poisoning.
- Shut down the heating system.
  - Ventilate the installation site.
  - Close doors to living spaces to prevent flue gases from spreading.

### What to do if water escapes from the appliance

-  **Danger**  
If water escapes from the appliance there is a risk of electrocution. Switch OFF the heating system at the external isolator (e.g. fuse box, domestic distribution board).

-  **Danger**  
If water escapes from the appliance there is a risk of scalding. Never touch hot heating water.

### Condensate

-  **Danger**  
Contact with condensate can be harmful to health. Never let condensate touch your skin or eyes and do not swallow it.

### Flue systems and combustion air

Ensure that flue systems are clear and cannot be sealed, for instance due to accumulation of condensate or other external causes. Ensure an adequate supply of combustion air. Inform system users that subsequent modifications to the building characteristics are not permissible (e.g. cable/pipe-work routing, cladding or partitions).

-  **Danger**  
Leaking or blocked flue systems, or an inadequate supply of combustion air can cause life threatening poisoning from carbon monoxide in the flue gas. Ensure the flue system is in good working order. Vents for supplying combustion air must be non-sealable.

### Extractors

Operating appliances that exhaust air to the outside (extractor hoods, extractors, air conditioning units, etc.) can create negative pressure. If the boiler is operated at the same time, this can lead to a reverse flow of flue gas.

**Safety instructions** (cont.)**Danger**









The simultaneous operation of the boiler and appliances that exhausts air to the outside can result in life threatening poisoning due to a reverse flow of flue gas.

Fit an interlock circuit or take suitable steps to ensure an adequate supply of combustion air.







**Index**

<b>1. Information</b>	Symbols .....	7
	Intended use .....	7
	Spare parts lists .....	8
<b>2. Commissioning, inspection, maintenance</b>	Steps - commissioning, inspection and maintenance .....	9
<b>3. Commissioning/service reports</b>	.....	19
<b>4. Specification</b>	.....	20
<b>5. Shutdown and disposal</b>	Final decommissioning and disposal .....	21
<b>6. Certificates</b>	Declaration of conformity .....	22
	Manufacturer's certificate according to the 1st BImSchV [Germany] ....	22
<b>7. Keyword index</b>	.....	23

## Symbols

Symbol	Meaning
	Reference to other document containing further information
	Step in a diagram: The numbers correspond to the order in which the steps are carried out.
	Warning of material losses and environmental pollution
	Live electrical area
	Pay particular attention.
	<ul style="list-style-type: none"> <li>▪ Component must audibly click into place.</li> <li>or</li> <li>▪ Acoustic signal</li> </ul>
	<ul style="list-style-type: none"> <li>▪ Fit new component.</li> <li>or</li> <li>▪ In conjunction with a tool: Clean the surface.</li> </ul>
	Dispose of component correctly.
	Dispose of component at a suitable collection point. Do <b>not</b> dispose of component in domestic waste.

The steps in connection with commissioning, inspection and maintenance are found in the "Commissioning, inspection and maintenance" section and identified as follows:

Symbol	Meaning
	Steps required during commissioning
	Not required during commissioning
	Steps required during inspection
	Not required during inspection
	Steps required during maintenance
	Not required during maintenance

## Intended use

The appliance is intended solely for installation and operation in sealed unvented heating systems that comply with EN 12828, with due attention paid to the associated installation, service and operating instructions. It is only designed for heating up heating water that is of potable water quality.

Intended use presupposes that a fixed installation in conjunction with permissible, system-specific components has been carried out.

Commercial or industrial usage for a purpose other than heating the building or DHW shall be deemed inappropriate.

Any usage beyond this must be approved by the manufacturer in each individual case.

Incorrect usage or operation of the appliance (e.g. the appliance being opened by the system user) is prohibited and will result in an exclusion of liability. Incorrect usage also occurs if the components in the heating system are modified from their intended use (e.g. if the flue gas and ventilation air paths are sealed).

## Spare parts lists

Information about spare parts can be found on the Viessmann spare parts app.







**Steps - commissioning, inspection and maintenance**

			Page
		Commissioning steps	
		Inspection steps	
		Maintenance steps	
•		1. Filling the heating system.....	10
•		2. Venting the boiler at the safety equipment block (accessories).....	11
•		3. Venting the heating system	
•	•	4. Shutting down the system	
•	•	5. Draining the heating system (if required).....	12
•	•	6. Opening the boiler door.....	12
•	•	7. Cleaning the heating surfaces.....	13
•	•	8. Checking the gaskets and thermal insulation sections.....	14
•	•	9. Fitting the boiler door.....	14
•	•	10. Separating the neutralising system or active charcoal filter (if installed) from the boiler and connecting the drain hose.....	15
•	•	11. Checking the neutralising system (if installed).....	15
•	•	12. Checking the active charcoal filter (if installed).....	15
•	•	13. Checking the connection on the flue gas side for leaks.....	16
•	•	14. Cleaning the condensate drain pipe and trap and reconnecting to the drainage system.....	16
•	•	15. Filling the trap and neutralising system (accessories) with water.....	16
•	•	16. Checking connections on the heating water and DHW sides and the sensor well for leaks	
•	•	17. Checking the function of the safety equipment	
•	•	18. Checking the expansion vessel and system pressure.....	17
•	•	19. Checking the thermal insulation for firm seating	
•	•	20. Checking the mixer for ease of operation and leaks.....	17
•	•	21. Checking the ventilation air connection to the burner (if installed).....	18
•	•	22. Adjusting the burner.....	18
•	•	23. Instructing the system user.....	18





### Fill water

According to EN 1717 with DIN 1988-100, as a heat transfer medium for DHW heating, the heating water must meet fluid category  $\leq 3$ . This requirement is met if water of potable quality is used as heating water. For example, if additives are used, the additive manufacturer must specify which category the treated heating water comes under.



#### Please note

Unsuitable fill water increases the level of deposits and corrosion and may lead to appliance damage.

- Flush the heating system thoroughly before filling.
- Only use fill water of potable water quality.
- Special antifreeze suitable for heating systems can be added to the fill water. The antifreeze manufacturer must verify its suitability.
- Fill and top-up water with a water hardness in excess of the following values must be softened, e.g. with a small softening system for heating water.

### Total permissible hardness of the fill and top-up water

Total heating output kW	Specific system volume		
	< 20 l/kW	$\geq 20$ l/kW to < 50 l/kW	$\geq 50$ l/kW
$\leq 50$	$\leq 3.0 \text{ mol/m}^3$ (16.8 °dH)	$\leq 2.0 \text{ mol/m}^3$ (11.2 °dH)	$< 0.02 \text{ mol/m}^3$ (0.11 °dH)
> 50 to $\leq 200$	$\leq 2.0 \text{ mol/m}^3$ (11.2 °dH)	$\leq 1.5 \text{ mol/m}^3$ (8.4 °dH)	$< 0.02 \text{ mol/m}^3$ (0.11 °dH)
> 200 to $\leq 600$	$\leq 1.5 \text{ mol/m}^3$ (8.4 °dH)	$\leq 0.02 \text{ mol/m}^3$ (0.11 °dH)	$< 0.02 \text{ mol/m}^3$ (0.11 °dH)
> 600	$< 0.02 \text{ mol/m}^3$ (0.11 °dH)	$< 0.02 \text{ mol/m}^3$ (0.11 °dH)	$< 0.02 \text{ mol/m}^3$ (0.11 °dH)

### With on-site boiler fill valve in the heating water return

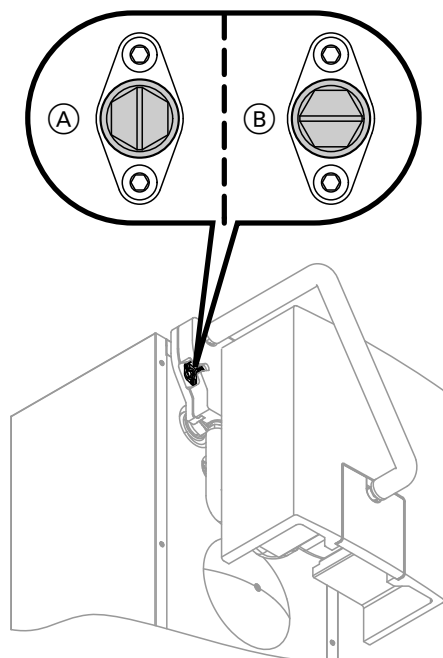

Fig. 1

- (A) Bypass valve "OPEN"
- (B) Bypass valve "CLOSED"

1. Check the pre-charge pressure of the expansion vessel.
2. Close the bypass valve on the boiler flow/return distributor.
3. If using a top-mounted Divicon heating circuit distributor (accessories):  
Set the mixer lever to "OPEN" (red).
4. Fill the system via the boiler fill valve in the heating water return, until it is fully vented.
5. Open the bypass valve on the boiler flow/return distributor again.



## Filling the heating system (cont.)

### With safety equipment block (accessories)

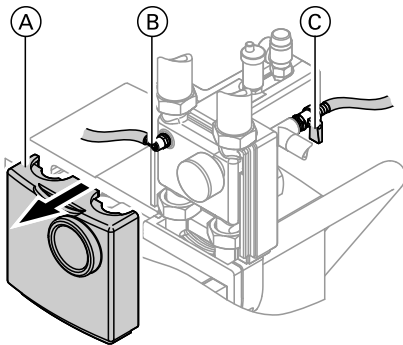

Fig. 2

1. Check the pre-charge pressure of the expansion vessel.
2. Close the bypass valve on the boiler flow/return distributor.
3. Remove front insulation shell (A).
4. Open air vent valve (B).
5. Fill the system via boiler fill valve (C) in the heating return. Minimum system pressure 0.8 bar (0.08 MPa).
6. Close air vent valve (B) when no more air escapes.
7. Close boiler fill valve (C).
8. Open the bypass valve on the boiler flow/return distributor again.



## Venting the boiler at the safety equipment block (accessories)

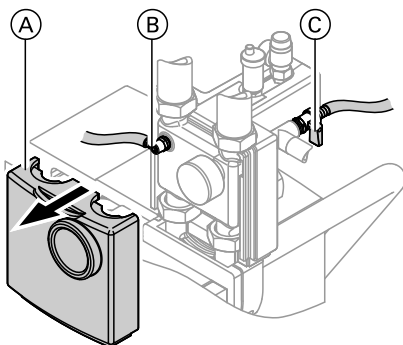

Fig. 3

1. Close the shut-off valves on the heating water side.
2. Remove front insulation shell (A) (if already fitted).
3. Connect the drain hose on air vent valve (B) to a drain.
4. Open valves (B) and (C) and vent at mains pressure until no sound of escaping air can be heard.
5. Close valves (B) and (C); open the shut-off valves on the heating water side.



## Venting the heating system



## Shutting down the system

   **Draining the heating system (if required)**

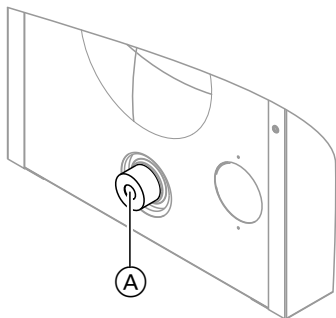

Fig. 4

 Drain

   **Opening the boiler door**

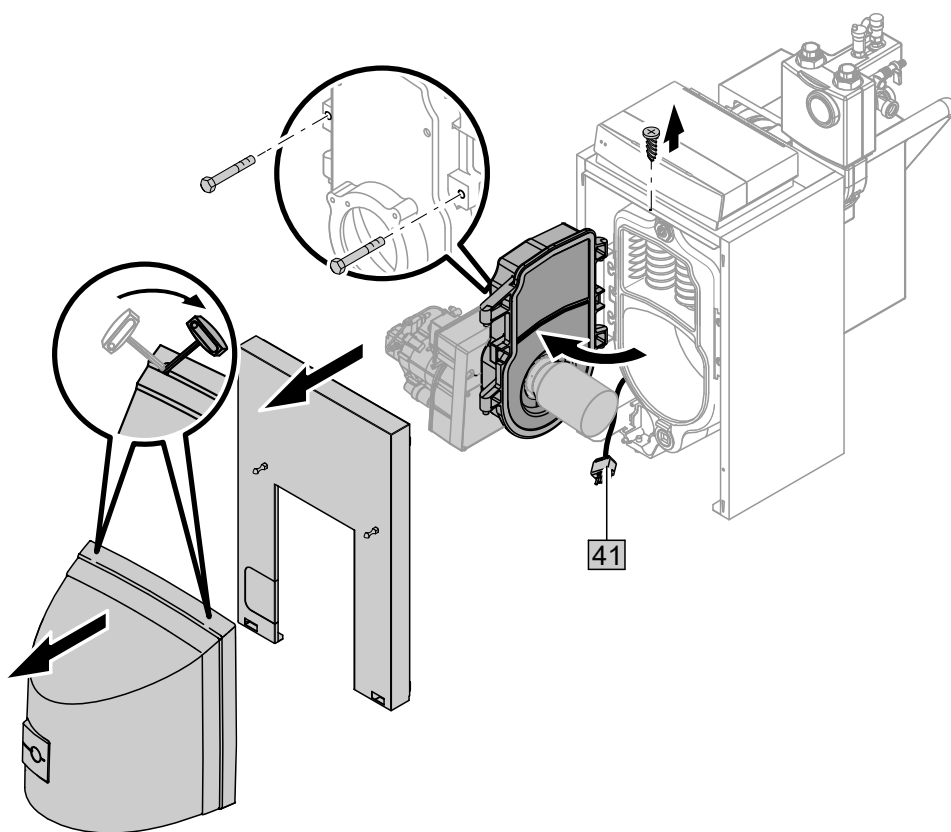

Fig. 5

For room sealed operation: Remove the ventilation air pipe before opening the boiler door.



## Cleaning the heating surfaces

### Boiler heating surface

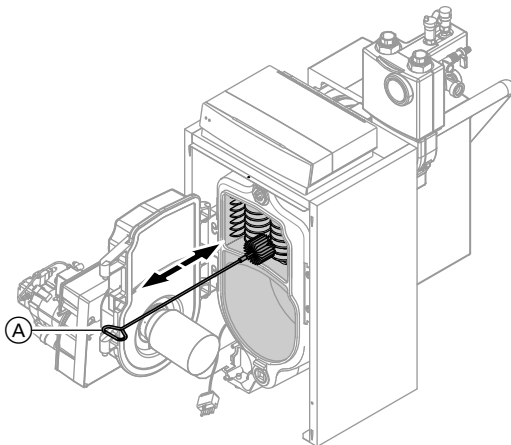

Fig. 6

(A) Cleaning brush (accessories)

1. Clean the combustion chamber and the boiler heating surfaces with a cleaning brush and vacuum cleaner.
2. Remove soot deposits with alkaline agents containing surfactant additives (e.g. Fauch 400/410<sup>\*1</sup>).

#### Note

Ensure that no cleaning agent gets between the boiler body and the thermal insulation.



Cleaning agent manufacturer's instructions

### Heating surface of the heat exchanger

#### Note

If the heating surfaces of the boiler and heat exchanger are only slightly soiled, the heat exchanger can be cleaned by flushing it thoroughly via the flue inspection cover.

To do so, detach condensate hose (A) from trap (B) and drain the dirty water into a suitable container (C).

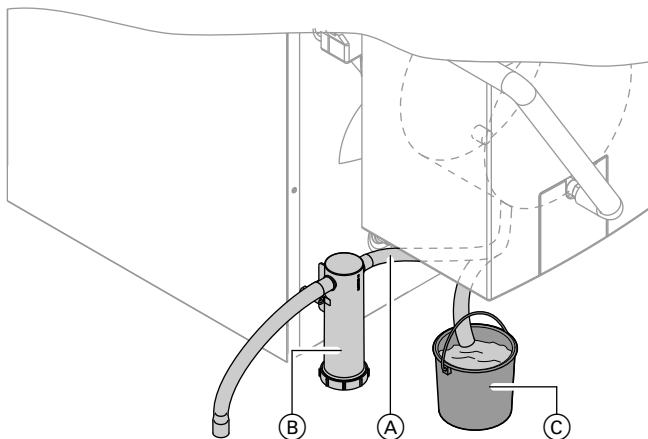

Fig. 7

1. Detach the heat exchanger from the boiler to clean it.
2. Remove contamination from the connector using a vacuum cleaner.
3. Loosen heavy deposits on the coil and gaps of the heat exchanger with a cleaning spatula<sup>\*2</sup> and remove using a vacuum cleaner.
4. Thoroughly flush the heating surface of the heat exchanger with water.
5. After cleaning, attach the heat exchanger in the reverse order.



#### Please note

Prevent components of the stainless steel heat exchanger that come into contact with hot gases from being scratched or otherwise damaged. Prevent stainless steel components that come into contact with hot gas from contact with pure iron, as corrosion damage can result. Never use a wire brush or sharp objects. Use plastic brushes if required.

For heavier soiling, proceed as follows:

<sup>\*1</sup> Manufacturer: Hebro Chemie GmbH, Rostocker Strasse 40, D-41199 Mönchengladbach

<sup>\*2</sup> Part no. 7840112

### **Cleaning the heating surfaces** (cont.)

For stubborn residues, surface stains or soot deposits, cleaning agents can be used.

For this, observe the following:

- Only use solvent-free cleaning agents.
- Remove soot deposits with alkaline agents containing surfactant additives (e.g. Fauch 400/410<sup>\*1</sup>).
- Combustion residues may create thin, yellow-brown surface stains as well as hard deposits. These may only become visible after the soot deposits have been removed. Discolouration on the surface of the stainless steel heat exchanger is a normal sign of use. It has no bearing on the function and service life of the heat exchanger. To remove hard deposits, use slightly acidic, chloride-free cleaning agents based on phosphoric acid (e.g. Antox 75 E<sup>\*1</sup>).
- Remove loosened deposits from the heat exchanger and rinse the heating surface thoroughly with water.

### **Checking the gaskets and thermal insulation sections**

1. Check gaskets and packing cords in the boiler door for damage.
2. Check the thermal insulation sections of the combustion chamber and the boiler door for damage.
3. Replace any damaged components.

### **Fitting the boiler door**

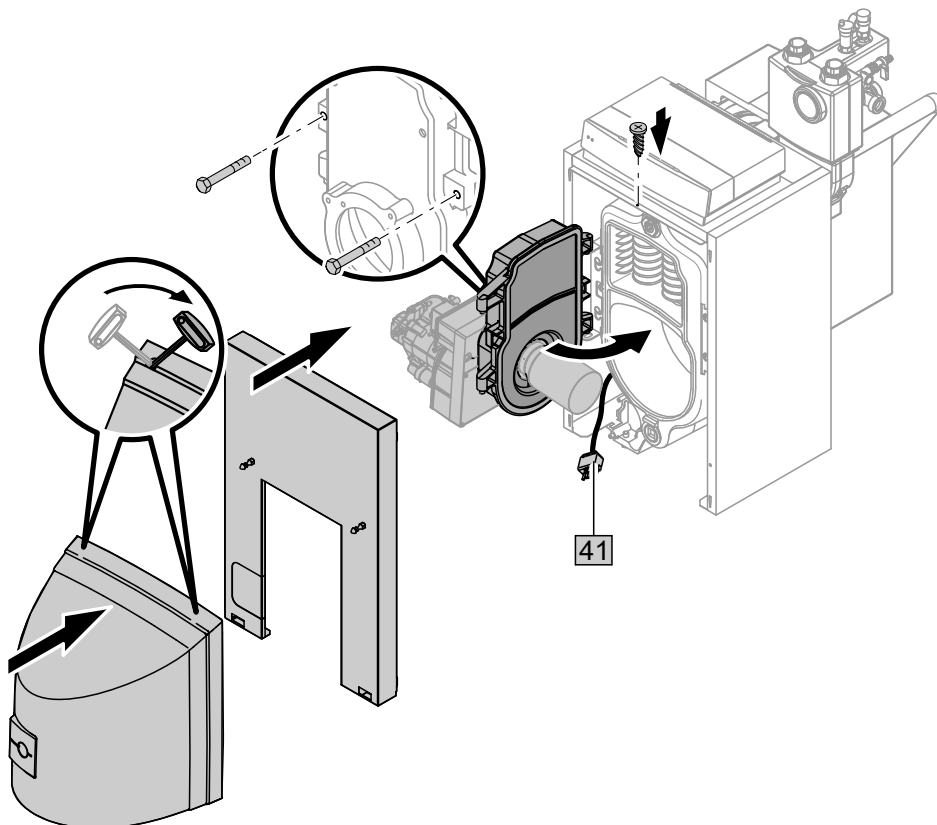

Fig. 8

For room sealed operation: Refit the ventilation air pipe after closing the boiler door.

<sup>\*1</sup> Manufacturer: Hebro Chemie GmbH, Rostocker Strasse 40, D-41199 Mönchengladbach



### Separating the neutralising system or active charcoal filter (if installed) from the boiler and connecting the drain hose

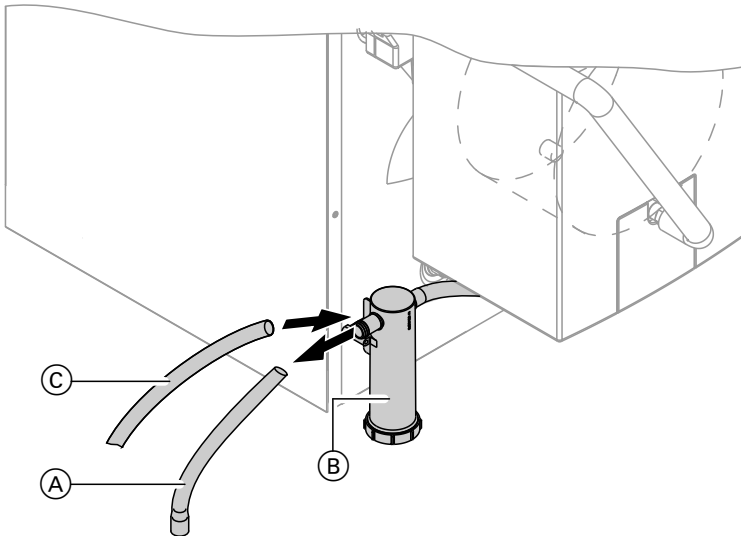

Fig. 9

1. Separate hose (A) to the neutralising system from trap (B).
2. Connect drain hose (C) to the condensate drain of the trap and run to a drainage system.



### Checking the neutralising system (if installed)

1. Check the pH value of the condensate downstream of the neutralising system with a pH test strip. Replace the granulate if the pH value is < 6.5.
2. Reinstall the neutralising system in reverse order.

**Note**

Part no. for pH test strips: 9517 678.

Observe the neutralising system manufacturer's instructions.



### Checking the active charcoal filter (if installed)

Observe the active charcoal filter manufacturer's instructions.



**Checking the connection on the flue gas side for leaks**

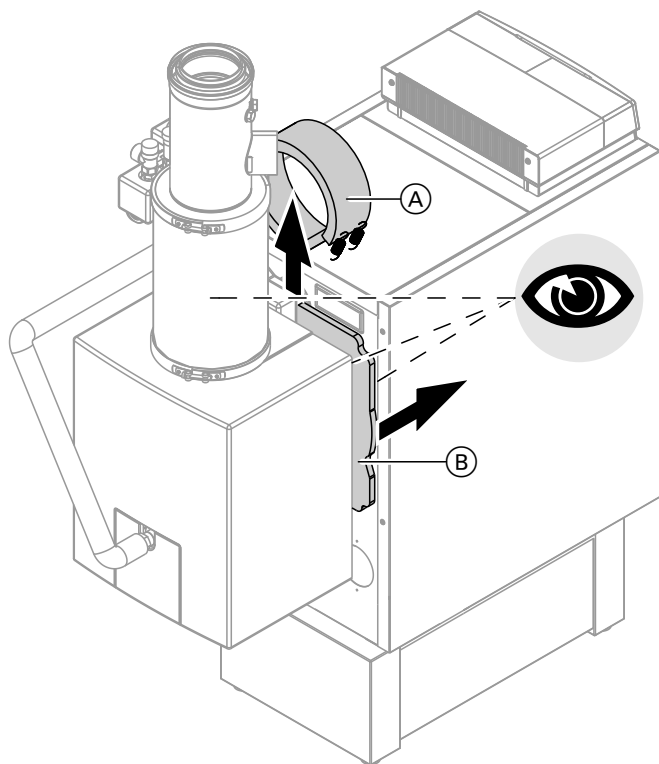

Fig. 10

**Note**

Traces of condensate indicate a leak.

1. Remove thermal insulation strip (A) and pull thermal insulation mat (B) out a little.
2. Check the heat exchanger fixings are firmly seated.
3. Check the connector on the heat exchanger for leaks.



**Cleaning the condensate drain pipe and trap and reconnecting to the drainage system**

Check that the hoses are routed without kinks and that the condensate can drain freely.



**Filling the trap and neutralising system (accessories) with water**

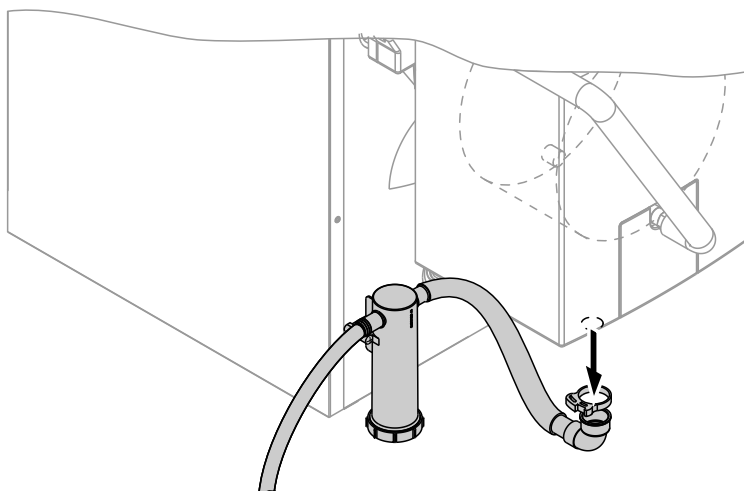

Fig. 11





### Filling the trap and neutralising system... (cont.)

Remove the supply hose (to the trap) from the boiler condensate drain and fill with a little water.



### Checking connections on the heating water and DHW sides and the sensor well for leaks



### Checking the function of the safety equipment



### Checking the expansion vessel and system pressure

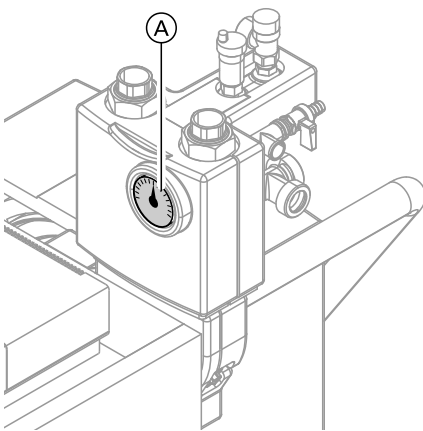

Fig. 12

(A) Pressure gauge

#### Note

Please observe expansion vessel manufacturer's instructions.

Carry out this test on a cold system.

1. Drain the system until the pressure gauge indicates "0" or close the cap valve on the expansion vessel and reduce the pressure in the expansion vessel.
2. If the pre-charge pressure of the expansion vessel is lower than the static system pressure, top up with nitrogen until the pre-charge pressure is 0.1 to 0.2 bar (10 to 20 kPa) higher.
3. Top up with water until the charge pressure of the cooled system is 0.1 to 0.2 bar (10 to 20 kPa) higher than the pre-charge pressure of the expansion vessel.  
Permiss. operating pressure: 3 bar (0.3 MPa)



### Checking the thermal insulation for firm seating



### Checking the mixer for ease of operation and leaks

1. Remove the motorised lever from the mixer handle and check the mixer for ease of operation.
2. Check the mixer for tightness. Replace the O-rings if the mixer leaks.



### Checking the mixer for ease of operation and... (cont.)

3. Click the motorised lever into place.



### Checking the ventilation air connection to the burner (if installed)

For room sealed operation: Check the ventilation air connection for damage.



### Adjusting the burner



Burner service instructions



### Instructing the system user

The system installer should hand the operating instructions to the system user and instruct the user in operating the system.

This includes all components installed as accessories, e.g. remote control units. In addition, the system installer must make the user aware of the required maintenance work.

**Commissioning/service reports**

	<b>Commissioning</b>	<b>Maintenance/service</b>	<b>Maintenance/service</b>
Date:			
By:			

	<b>Maintenance/service</b>	<b>Maintenance/service</b>	<b>Maintenance/service</b>
Date:			
By:			

	<b>Maintenance/service</b>	<b>Maintenance/service</b>	<b>Maintenance/service</b>
Date:			
By:			

	<b>Maintenance/service</b>	<b>Maintenance/service</b>	<b>Maintenance/service</b>
Date:			
By:			

	<b>Maintenance/service</b>	<b>Maintenance/service</b>	<b>Maintenance/service</b>
Date:			
By:			

## Specification

### Specification

<b>Rated heating output</b>							
$T_F/T_R = 50/30 \text{ }^\circ\text{C}$	<b>kW</b>	<b>20.2</b>	<b>24.6</b>	<b>28.6</b>	<b>35.4</b>	<b>42.8</b>	<b>53.7</b>
$T_F/T_R = 80/60 \text{ }^\circ\text{C}$	<b>kW</b>	<b>18.8</b>	<b>22.9</b>	<b>27.0</b>	<b>33.0</b>	<b>40.0</b>	<b>50.0</b>
<b>CE designation</b>		CE-2456 CL 102					
<b>Power consumption<sup>*3</sup> at</b>							
▪ 100 % of rated heating output	W	226	215	235	235	340	340
▪ 30 % of rated heating output	W	60	66	73	80	113	113
<b>Available draught<sup>*4</sup></b>							
	Pa	100	100	100	100	100	100
	mbar	1.0	1.0	1.0	1.0	1.0	1.0
<b>Flue gas temperature<sup>*5</sup></b>							
▪ At a return temperature of 30 °C	°C	32	34	37	39	36	40
▪ At a return temperature of 60 °C	°C	62	63	65	67	64	67

<sup>\*3</sup> Standard parameter (in conjunction with Vitoflame 300 blue flame oil burner).

<sup>\*4</sup> Observe when sizing the chimney.

<sup>\*5</sup> Flue gas temperatures as average gross values to EN 304 (captured with 5 thermocouples) at 20 °C combustion air temperature.

## Final decommissioning and disposal

Viessmann products can be recycled. Components and substances from the system are not part of ordinary household waste.

For decommissioning the system, isolate the system from the power supply and allow components to cool down where appropriate. All components must be disposed of correctly.

## Certificates

### Declaration of conformity

We, Viessmann Werke GmbH & Co. KG, D-35107 Allendorf, declare as sole responsible body that the named product complies with the European directives and supplementary national requirements in terms of its design and operational characteristics.

Using the serial number, the full Declaration of Conformity can be found on the following website:  
**[www.viessmann.co.uk/eu-conformity](http://www.viessmann.co.uk/eu-conformity)**

This product meets the requirements of the Efficiency Directive (92/42/EEC) for **condensing boilers**.

### Manufacturer's certificate according to the 1st BImSchV [Germany]

We, Viessmann Werke GmbH & Co. KG, D-35107 Allendorf, confirm that the following product meets the NO<sub>x</sub> limits specified by the 1st BImSchV Paragraph 6:

#### Vitorondens 200-T oil Unit condensing boiler

Allendorf, 7 November 2017

Viessmann Werke GmbH & Co. KG



Authorised signatory Reiner Jansen  
Head of Strategic Quality Management

## Keyword index

<b>B</b>		<b>I</b>	
Boiler, venting.....	11	Intended use.....	7
Boiler door		<b>N</b>	
– Fitting.....	14	Neutralising system.....	15
– Opening.....	12		
<b>C</b>		<b>R</b>	
Checking the active charcoal filter.....	15	Room sealed operation.....	12, 14, 18
Cleaning the heating surfaces.....	13	<b>S</b>	
Commissioning.....	10	Shutdown.....	21
Connection on the flue gas side.....	16	Specification.....	20
<b>D</b>		Symbols.....	7
Disposal.....	21	System	
<b>E</b>		– Draining.....	12
Expansion vessel.....	10, 11, 17	– Filling.....	10, 11
<b>F</b>		System pressure.....	11
Fill water.....	10	<b>T</b>	
<b>G</b>		Thermal insulation sections.....	14
Gaskets and packing cords.....	14	Trap	
<b>H</b>		– Cleaning.....	16
Heat exchanger.....	16	– Filling.....	16
Heating system			
– Draining.....	12		
– Filling.....	10, 11		

Viessmann Werke GmbH & Co. KG  
D-35107 Allendorf  
Telephone: +49 6452 70-0  
Fax: +49 6452 70-2780  
[www.viessmann.com](http://www.viessmann.com)



Viessmann Limited  
Hortonwood 30, Telford  
Shropshire, TF1 7YP, GB  
Telephone: +44 1952 675000  
Fax: +44 1952 675040  
E-mail: [info-uk@viessmann.com](mailto:info-uk@viessmann.com)

5624309 Subject to technical modifications.