

Installation and service instructions

for contractors

VIESSMANN

Vitodens 100-W

Type B1HC, B1KC, 4.7 to 35.0 kW

Wall mounted gas condensing boiler

Natural gas and LPG version

Gas Council Number: 41-819-40, 41-819-41, 41-819-42, 41-819-43, 47-819-40,
47-819-41, 47-819-42



VITODENS 100-W



Safety instructions

-  Please follow these safety instructions closely to prevent accidents and material losses.

Safety instructions explained

-  **Danger**
This symbol warns against the risk of injury.

-  **Please note**
This symbol warns against the risk of material losses and environmental pollution.

Note
Details identified by the word "Note" contain additional information.

Target group

These instructions are exclusively intended for qualified contractors.

- Work on gas installations may only be carried out by a registered gas fitter.
- Work on electrical equipment may only be carried out by a qualified electrician.
- The system must be commissioned by the system installer or a qualified person authorised by the installer.

Regulations to be observed

- National installation regulations
- Statutory regulations for the prevention of accidents
- Statutory regulations for environmental protection
- Codes of practice of the relevant trade associations
- Relevant country-specific safety regulations

Safety instructions for working on the system

Working on the system

- Where gas is used as the fuel, close the main gas shut-off valve and safeguard it against unintentional reopening.
- Isolate the system from the power supply, e.g. by removing the separate fuse or by means of a mains isolator, and check that it is no longer live.
- Safeguard the system against reconnection.
- Wear suitable personal protective equipment when carrying out any work.

Safety instructions (cont.)**Danger**

Hot surfaces and fluids can lead to burns or scalding.

- Before maintenance and service work, switch OFF the appliance and let it cool down.
- Never touch hot surfaces on the boiler, burner, flue system or pipe-work.

**Please note**

Electronic assemblies can be damaged by electrostatic discharge. Prior to commencing work, touch earthed objects such as heating or water pipes to discharge static loads.

Repair work**Please note**

Repairing components that fulfil a safety function can compromise the safe operation of the system. Replace faulty components only with genuine Viessmann spare parts.

Auxiliary components, spare and wearing parts**Please note**

Spare and wearing parts that have not been tested together with the system can compromise its function. Installing non-authorised components and making non-approved modifications or conversions can compromise safety and may invalidate our warranty. For replacements, use only original spare parts supplied or approved by Viessmann.

Safety instructions for operating the system

If you smell gas

-  **Danger**
Escaping gas can lead to explosions which may result in serious injury.
- Do not smoke. Prevent naked flames and sparks. Never switch lights or electrical appliances on or off.
 - Close the gas shut-off valve.
 - Open windows and doors.
 - Evacuate any people from the danger zone.
 - Notify your gas or electricity supply utility from outside the building.
 - Have the power supply to the building shut off from a safe place (outside the building).

If you smell flue gas

-  **Danger**
Flue gas can lead to life threatening poisoning.
- Shut down the heating system.
 - Ventilate the installation site.
 - Close doors to living spaces to prevent flue gases from spreading.

What to do if water escapes from the appliance

-  **Danger**
If water escapes from the appliance there is a risk of electrocution. Switch OFF the heating system at the external isolator (e.g. fuse box, domestic distribution board).

-  **Danger**
If water escapes from the appliance there is a risk of scalding. Never touch hot heating water.

Condensate

-  **Danger**
Contact with condensate can be harmful to health. Never let condensate touch your skin or eyes and do not swallow it.

Flue systems and combustion air

Ensure that flue systems are clear and cannot be sealed, for instance due to accumulation of condensate or other external causes. Ensure an adequate supply of combustion air. Inform system users that subsequent modifications to the building characteristics are not permissible (e.g. cable/pipe-work routing, cladding or partitions).

-  **Danger**
Leaking or blocked flue systems, or an inadequate supply of combustion air can cause life threatening poisoning from carbon monoxide in the flue gas. Ensure the flue system is in good working order. Vents for supplying combustion air must be non-sealable.

Extractors

Operating appliances that exhaust air to the outside (extractor hoods, extractors, air conditioning units, etc.) can create negative pressure. If the boiler is operated at the same time, this can lead to a reverse flow of flue gas.

Safety instructions (cont.)**Danger**

The simultaneous operation of the boiler and appliances that exhausts air to the outside can result in life threatening poisoning due to a reverse flow of flue gas.

Fit an interlock circuit or take suitable steps to ensure an adequate supply of combustion air.

1. Information	Disposal of packaging	8
	Symbols	8
	Intended use	8
	Product information	9
	■ Vitodens 100-W, type B1HC, B1KC	9
	Product description	9
	■ DHW heating with DHW cylinder	9
	■ Connection accessories	9
	System examples	10
	Spare parts lists	10
2. Preparing for installation	11
3. Installation sequence	Mounting the boiler and making connections	14
	■ Hooking the boiler onto the wall mounting bracket	14
	■ Fitting the connections on the water side	14
	■ Gas connection	16
	■ Connecting the safety valve and condensate drain	16
	■ Filling the trap with water	17
	■ Balanced flue connection	17
	Removing the front panel	18
	Opening the control unit enclosure	18
	Electrical connections	19
	■ Cable entry	21
	■ Outside temperature sensor (accessories)	21
	■ Vitotrol 100 connection	21
	■ Power supply	22
	■ Routing cables/leads and closing the control unit enclosure	22
4. Commissioning, inspection, maintenance	Steps - commissioning, inspection and maintenance	23
5. Changing the gas type	Changing from operation with LPG to operation with natural gas	48
	■ Checking the CO ₂ content	49
6. Troubleshooting	Function sequence and possible faults	50
	Fault display	50
	Repairs	53
	■ Removing the front panel	53
	■ Outside temperature sensor	54
	■ Boiler water temperature sensor	55
	■ Checking the cylinder temperature sensor (gas condensing system boiler)	56
	■ Checking the temperature limiter	56
	■ Checking the outlet temperature sensor (gas condensing combi boiler)	57
	■ Checking the flue gas temperature sensor	58
	■ Replacing the flow limiter (gas condensing combi boiler)	59
	■ Checking or replacing the plate heat exchanger (gas condensing combi boiler)	60
	■ Checking the fuse	61
7. Control unit	Functions and operating conditions in weather-compensated mode	62
	■ Heating curve for weather-compensated control	62
	■ Frost protection function	62
8. Connection and wiring diagram	63
9. Reports	64









Index (cont.)

10. Specification	65
11. Disposal	Final decommissioning and disposal	67
12. Certificates	Declaration of Conformity	68
13. Keyword index	69







Disposal of packaging

Please dispose of packaging waste in line with statutory regulations.

Symbols

Symbol	Meaning
	Reference to other document containing further information
	Step in a diagram: The numbers correspond to the order in which the steps are carried out.
	Warning of material losses and environmental pollution
	Live electrical area
	Pay particular attention.
	<ul style="list-style-type: none"> Component must audibly click into place. or Acoustic signal
	<ul style="list-style-type: none"> Fit new component. or In conjunction with a tool: Clean the surface.
	Dispose of component correctly.
	Dispose of component at a suitable collection point. Do not dispose of component in domestic waste.

The steps in connection with commissioning, inspection and maintenance are found in the "Commissioning, inspection and maintenance" section and identified as follows:

Symbol	Meaning
	Steps required during commissioning
	Not required during commissioning
	Steps required during inspection
	Not required during inspection
	Steps required during maintenance
	Not required during maintenance

Intended use

The appliance is intended solely for installation and operation in sealed unvented heating systems that comply with EN 12828, with due attention paid to the associated installation, service and operating instructions. It is only designed for heating up heating water that is of potable water quality.

Intended use presupposes that a fixed installation in conjunction with permissible, system-specific components has been carried out.

Commercial or industrial usage for a purpose other than heating the building or DHW shall be deemed inappropriate.

Any usage beyond this must be approved by the manufacturer in each individual case.

Intended use (cont.)

Incorrect usage or operation of the appliance (e.g. the appliance being opened by the system user) is prohibited and will result in an exclusion of liability. Incorrect usage also occurs if the components in the heating system are modified from their intended use (e.g. if the flue gas and ventilation air paths are sealed).

Product information

Vitodens 100-W, type B1HC, B1KC

Preset for operation with natural gas

The Vitodens 100-W may only be delivered to the countries specified on the type plate. For deliveries to other countries, approved contractors must arrange individual approval on their own initiative and in accordance with the law of the country in question. The type plate is located on the top of the boiler.

Product description

The Vitodens 100-W is available as a gas condensing system boiler for the connection of one DHW cylinder and as a gas condensing combi boiler with an integral plate heat exchanger for DHW heating. For the connection of heating circuits and the DHW cylinder or the DHW line, see page 14 onwards.

In the delivered condition, the Vitodens 100-W is set up for operation with a constant boiler water temperature. By connecting an outside temperature sensor (accessories), the boiler can be operated in weather-compensated mode.

The following are integrated: one sealed unvented hydraulic system with 2 connections for heating flow and return, and 2 connections for cylinder heating (gas condensing system boiler) or DHW heating (gas condensing combi boiler).

These boilers are only intended for installation in sealed unvented heating systems. Boilers for open vented heating systems are also available. If the Vitodens 100-W is installed in an S plan or Y plan system, the two internal connections are not used and must be capped off during installation.

The following components are integrated into the hydraulic system:

- Circulation pump
- 3-way diverter valve
- Safety valve
- Diaphragm expansion vessel
- Plate heat exchanger for DHW heating (gas condensing combi boiler)

DHW heating with DHW cylinder

If a Viessmann Vitocell is connected, a cylinder temperature sensor will issue the heat demand (accessories). The cylinder temperature sensor is connected to the boiler control unit. A 230 V cylinder temperature controller is not required.

The cylinder temperature sensor (accessories) can also be used if a different DHW cylinder is connected. Alternatively, a 230 V cylinder temperature controller should be connected via the cylinder demand junction box.

Connection accessories

Cylinder temperature sensor, outside temperature sensor and time switch are connected to the control unit with low voltage.

System examples

Available system examples: See www.viessmann-schemes.com.

Spare parts lists

Information about spare parts can be found at www.viessmann.com/etapp or in the Viessmann spare part app.



Preparing for installation

Preparing for boiler installation

Dimensions and connections

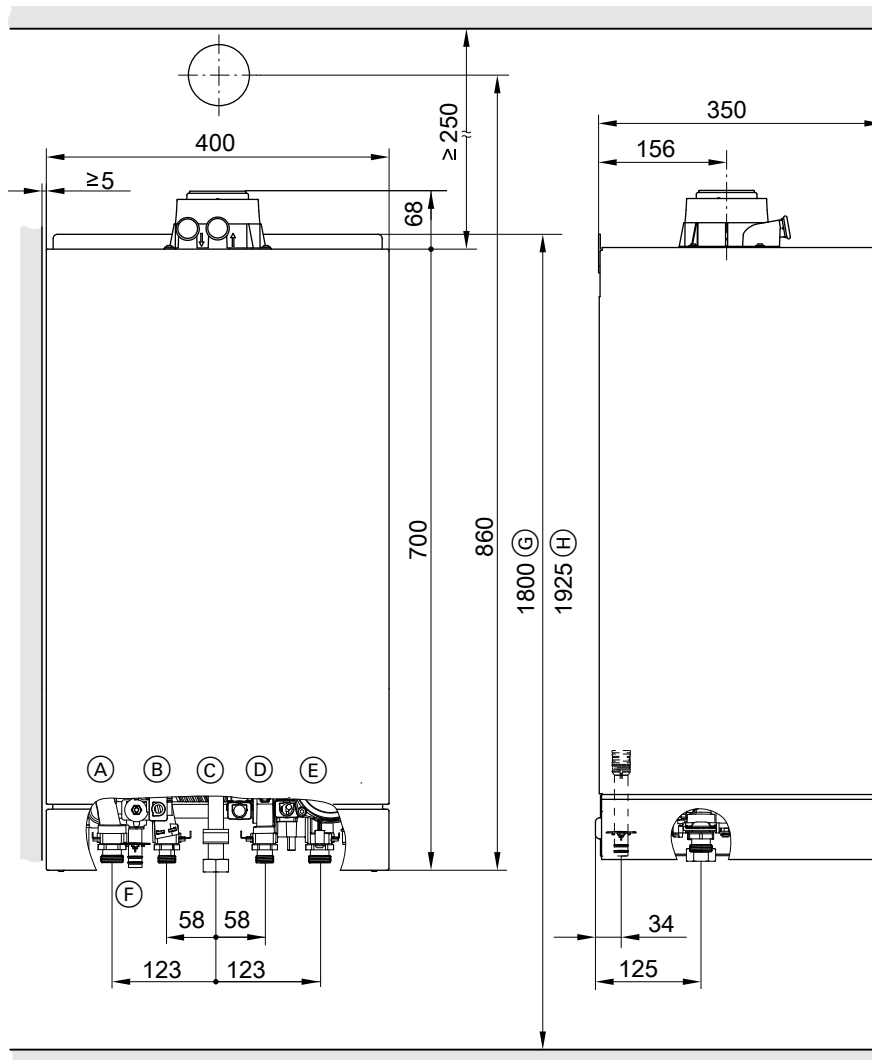

Fig. 1

- (A) Heating flow \varnothing 22 mm
- (B) Gas condensing system boiler:
Cylinder flow G $\frac{3}{4}$
Gas condensing combi boiler:
DHW \varnothing 15 mm
- (C) Gas connection
- (D) Gas condensing system boiler:
Cylinder return G $\frac{3}{4}$
Gas condensing combi boiler:
Cold water \varnothing 15 mm
- (E) Heating return \varnothing 22 mm
- (F) Condensate drain/safety valve drain: plastic hose
 \varnothing 22 mm
- (G) Compulsory in conjunction with DHW cylinder
below the boiler
- (H) Recommendation for installation without DHW cylinder
below the boiler

Note

Dimensions of connections in conjunction with the connection accessories provided

Preparing for installation

Preparing for installation (cont.)

Fitting the wall mounting bracket

Only for installation without installation aid or mounting frame

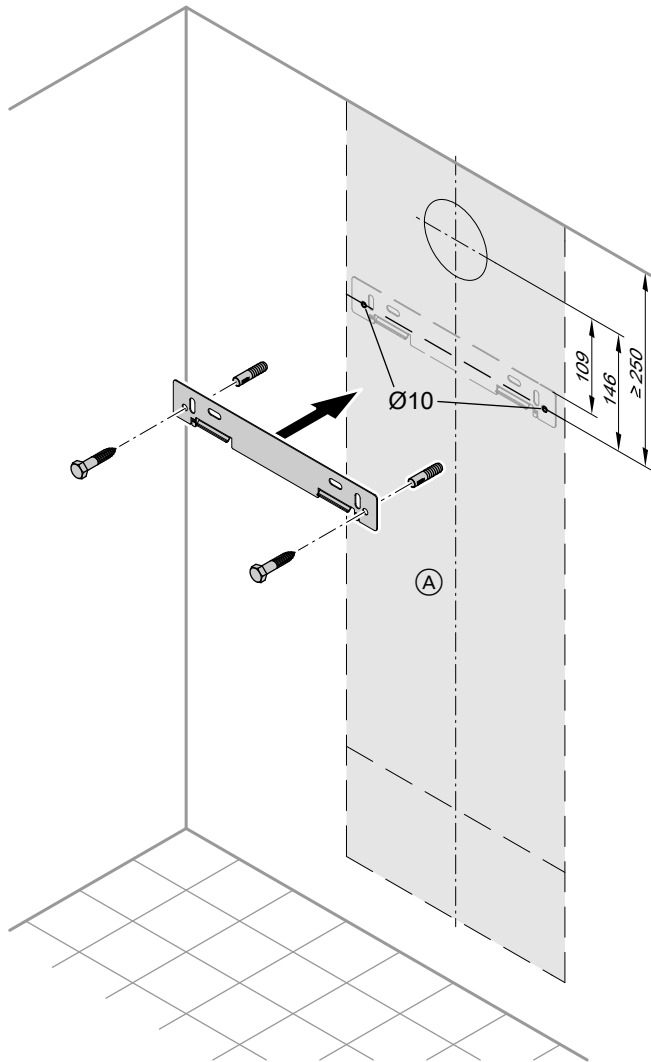

Fig. 2

(A) Vitodens installation template

Fitting the pre-plumbing jig or mounting frame (accessories)



Pre-plumbing jig or mounting frame installation instructions

Preparing the connections



Please note

To prevent appliance damage, connect all pipework free of load and torque stress.

1. Position the supplied installation template on the wall.
2. Mark out the rawl plug holes.
3. Drill \varnothing 10 mm holes and insert the rawl plugs supplied.

Note

The supplied rawl plugs are suitable for the following materials:

- Concrete
 - Vertically perforated bricks
 - Hollow concrete breeze blocks
 - Hollow brick and concrete ceilings
 - Perforated sand lime bricks
 - Solid sand lime bricks
 - Natural stone with dense structure
 - Porous concrete
 - Solid gypsum panels
 - Solid concrete breeze blocks
 - Solid bricks
4. Fit the wall mounting bracket with the screws supplied.

Note

This boiler (IP rating: IP X4) is approved for installation in wet rooms inside safety zone 1 in accordance with IEEE Wiring Regulations, providing the occurrence of hoses water can be ruled out.

Observe the IEEE Wiring Regulations.

1. Prepare the water connections. Flush the heating system.
2. Prepare the gas connection.

Preparing for installation (cont.)

3. Prepare the electrical connections.
 - Power cable:
A flexible cable 3 x 1.0 mm², approx. 1.5 m long is connected in the delivered condition.
 - Cables for accessories:
2-core sheathed cable min. 0.5 mm² for low voltage

Mounting the boiler and making connections

Hooking the boiler onto the wall mounting bracket

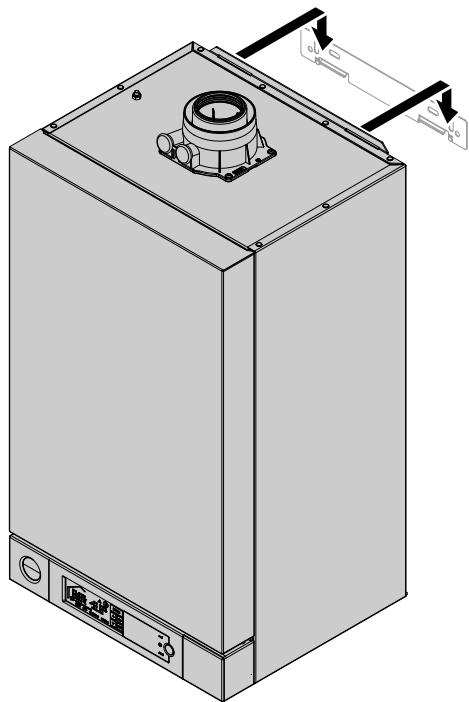



Fig. 3

Fitting the connections on the water side

 For installation of fittings on the heating water side and DHW side, see separate installation instructions.

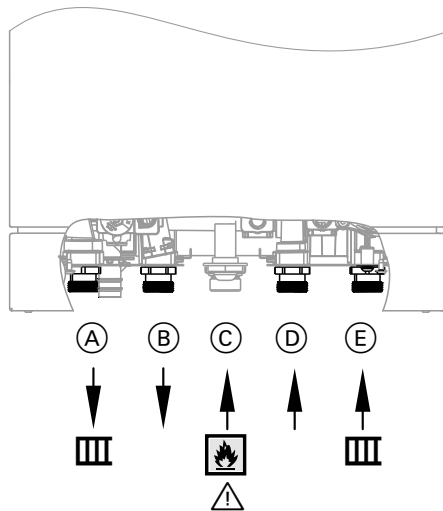

Fig. 4

- (A) Heating flow
- (B) Gas condensing system boiler:
Cylinder flow
Gas condensing combi boiler:
DHW
- (C) Gas connection
- (D) Gas condensing system boiler:
Cylinder return
Gas condensing combi boiler:
Cold water
- (E) Heating return

Mounting the boiler and making connections (cont.)

Gas condensing system boiler

Permiss. DHW operating pressure: 10 bar (1.0 MPa)

Note
Install a pressure reducer if required.

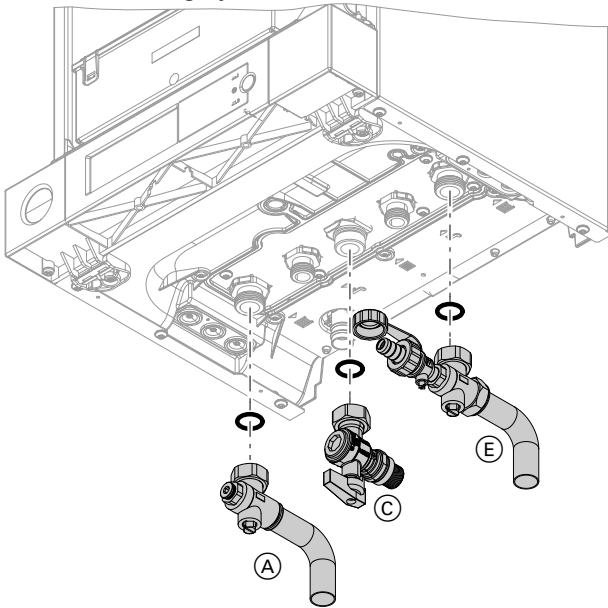

Fig. 5

Gas condensing combi boiler

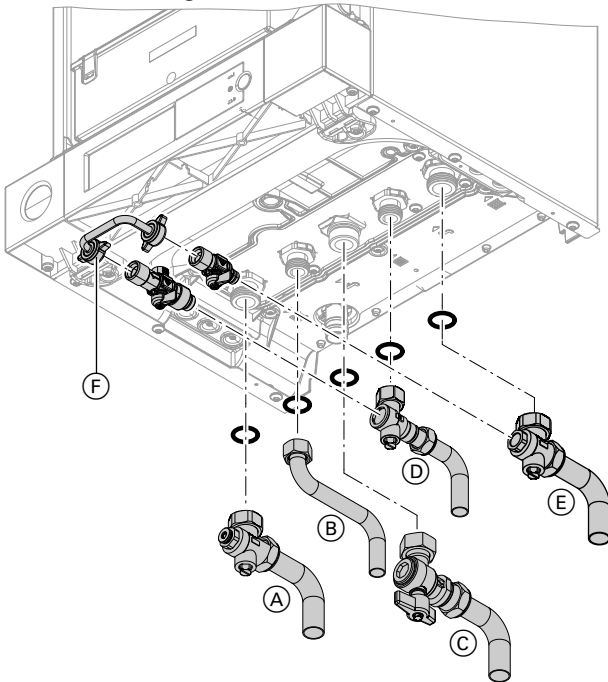

Fig. 6

Ⓕ Filling device

Gas connection

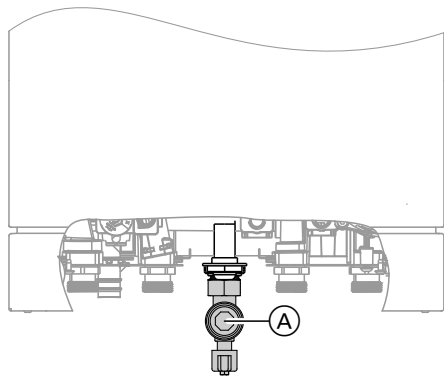

Fig. 7

1. Connect the gas shut-off valve to connection (A).
2. Check the gas connections for leaks.

Note

Only use suitable and approved leak detection agents (EN 14291) and devices for the tightness test. Leak detection agents with unsuitable constituents (e.g. nitrides, sulphides) can cause material damage.

Remove residues of the leak detection agent after testing.



Please note

Excessive test pressure will damage the boiler and the gas train.

Max. test pressure 150 mbar (15 kPa).

Where higher pressure is required for tightness tests, disconnect the boiler and the gas train from the main supply pipe (undo the fitting).

3. Purge the gas line.

Connecting the safety valve and condensate drain

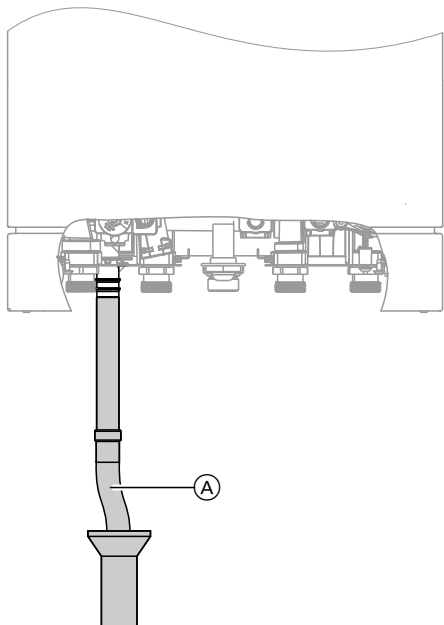

Fig. 8

- The condensate pipe is connected to the discharge pipe of the safety valve. The condensate hose supplied meets the temperature requirements that are part of the CE certification.
- We recommend connecting the condensate pipe to the internal domestic waste water system, either directly or via a tundish.
- If the condensate pipe is routed outside the building, use a pipe with min. \varnothing 30 mm and protect the pipe from frost. Avoid long external pipe runs.



Please note

A frozen condensate pipe can result in faults and damage to the boiler.

Always protect condensate pipes against frost.

- Observe local building regulations. Connect condensate pipe (A) to the waste water system with a constant fall and a pipe vent. Observe local waste water regulations.

Note

Fill the trap with water before commissioning.

Mounting the boiler and making connections (cont.)

Filling the trap with water

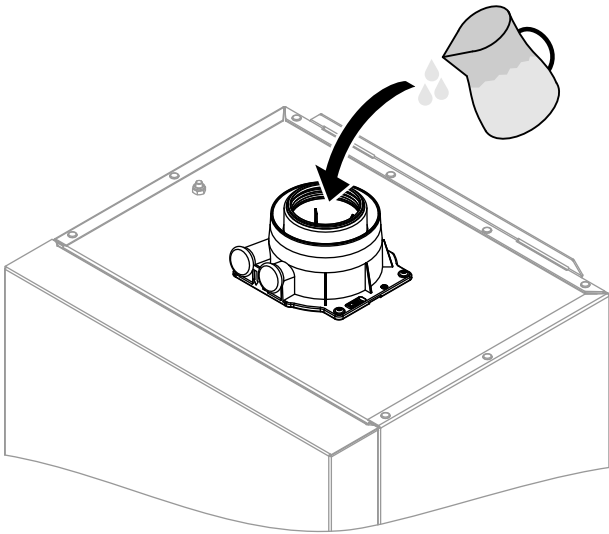

Fig. 9

Pour at least 0.3 l of water into the flue gas connection.



Please note

During commissioning, flue gas may escape from the condensate drain. Always fill the trap with water before commissioning.

Balanced flue connection

Note

Only use the "System certificate" and "Skoberne GmbH flue system" labels in conjunction with the Viessmann flue system made by Skoberne.

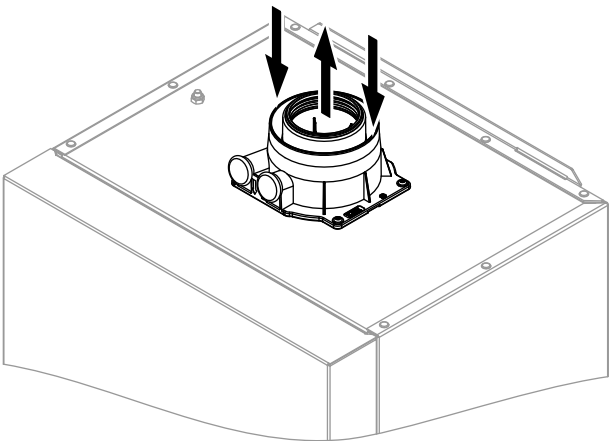

Fig. 10

Connect the balanced flue pipe. During installation and positioning of the flue system, observe Building Regulations Part L and BS 5440.



Flue system installation instructions

Connecting several Vitodens 100-W to a shared flue system

Adjust the burner settings of each connected boiler to match the flue system:

- For shared connection, see page 30.
- For flue gas cascade, see page 36.

If several Vitodens are connected to a common flue system: Install a back draught safety device (accessories) in the flue gas connection and in the mixing shaft of the burner on each boiler.

Installing the back draught safety devices:



Installation instructions for back draught safety device

Do not carry out **commissioning** until the following conditions are met:

- Free passage through the flue gas pipes.
- Flue system with positive pressure is gas-tight.
- Inspection port covers checked for secure and tight seating.
- Apertures for ensuring sufficient combustion air supply are open and cannot be closed off.
- Applicable regulations on installing and commissioning flue systems have been followed.



Danger

Leaking or blocked flue systems or an insufficient supply of combustion air cause life-threatening poisoning due to carbon monoxide in the flue gas.

Ensure the flue system functions correctly. Apertures for combustion air supply must not be able to be closed off.

Prevent condensate drainage via a wind protector.

Installation sequence

Removing the front panel

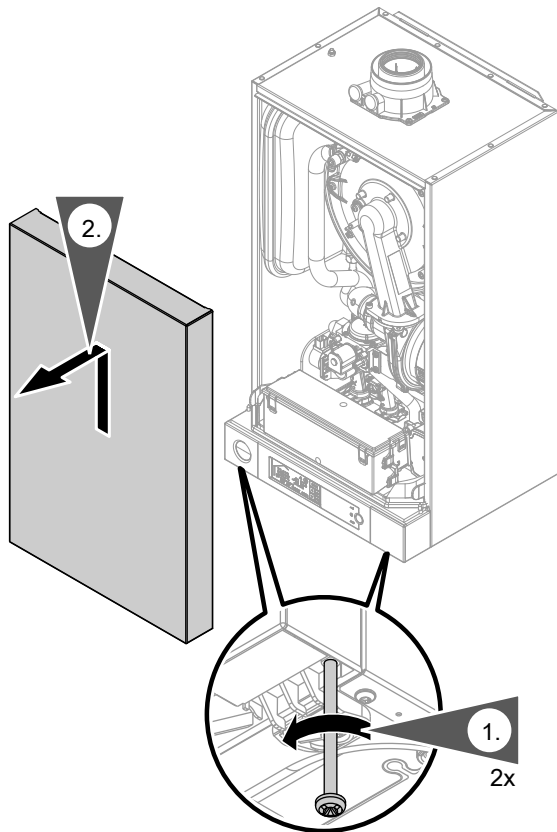

Fig. 11

1. Undo the screws on the underside of the boiler; do not remove them completely.
2. Remove front panel.

Opening the control unit enclosure

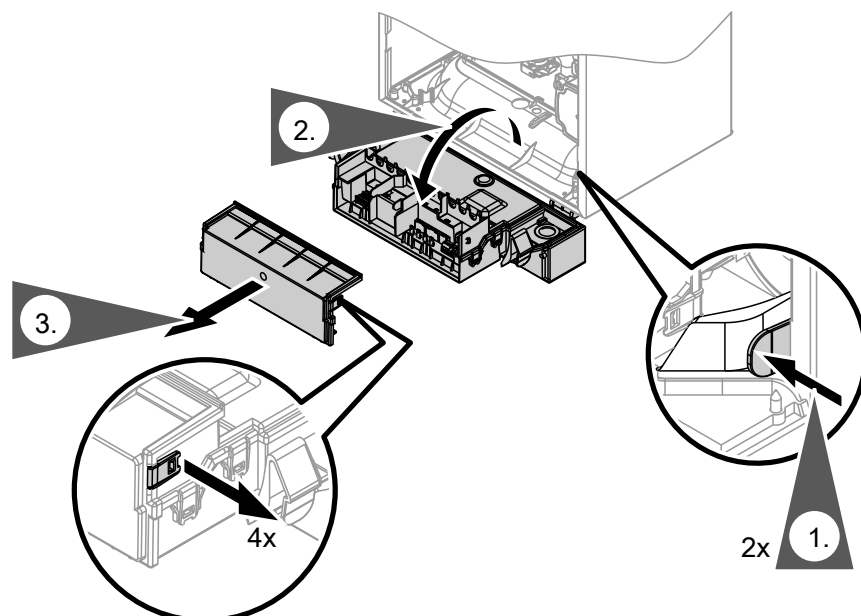

Fig. 12

Opening the control unit enclosure (cont.)

- ! Please note**
 Electronic assemblies can be damaged by electrostatic discharge.
 Prior to commencing any work, touch earthed objects such as heating or water pipes to discharge static loads.

Electrical connections

Information on connecting accessories
 When connecting accessories observe the separate installation instructions provided with them.

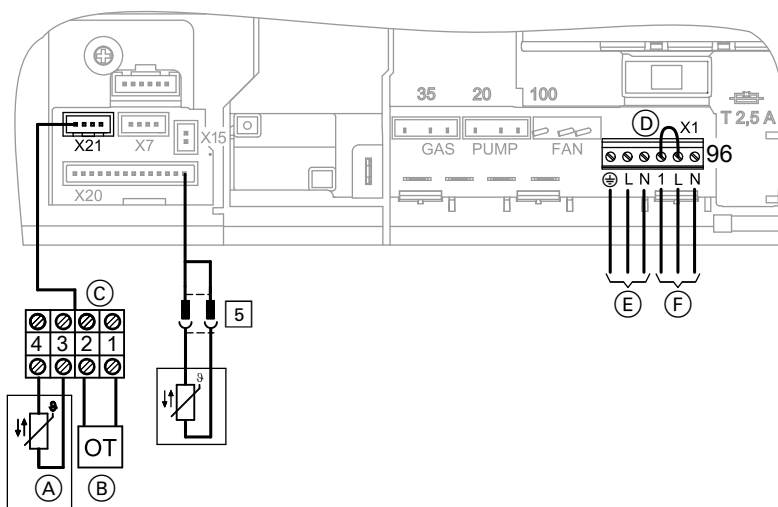

Fig. 13

- (A) Only for weather-compensated mode:
Outside temperature sensor (accessories)
- (B) OpenTherm device
Remove jumper (D) when making this connection.
- (C) Connecting cable
- (D) Jumper
- (E) Power supply (230 V, 50 Hz)
See page 22.
- (F) Vitotrol 100 or on-site room temperature controller (230 V switched input)
Remove jumper (D) when making this connection.
 - Separate installation instructions
- [5] Gas condensing system boiler:
 - With Viessmann DHW cylinders: cylinder temperature sensor (plug on the cable harness outside the control unit)
 - In the case of alternative DHW cylinders compliant with the G3 Directive:
Cylinder demand junction box (for connection of a cylinder temperature controller and a 2-way shut-off valve)
 - Operation without DHW cylinder:
Set the set DHW temperature to "OFF".
 - Operating instructions

Electrical connections (cont.)

Cable entry

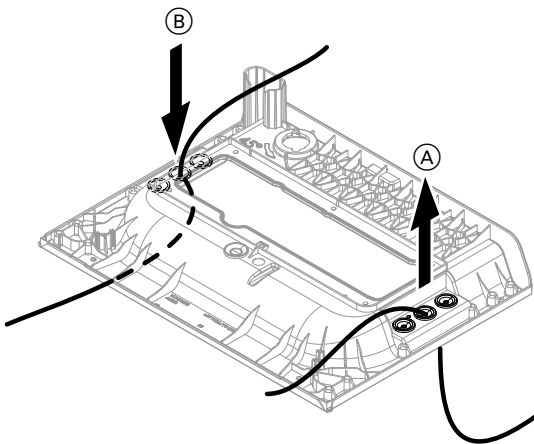

Fig. 15

- (A) Power cable, remote control connecting cable
- (B) LV leads (sensor leads)

Outside temperature sensor (accessories)

1. Fit the outside temperature sensor.

Installation location:

- North or north-westerly wall, 2 to 2.5 m above ground level; in multi storey buildings, in the upper half of the second floor
- Not above windows, doors or vents
- Not immediately below balconies or gutters
- Never render over.
- Connection:
 - 2-core lead, length up to 35 m with a cross-section of 1.5 mm²

2. Connect the outside temperature sensor to the connecting cable across terminals 3 and 4 at slot "X21" (see page 19).

Vitotrol 100 connection

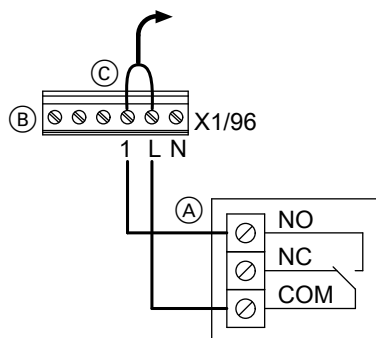

Fig. 16 Example: Vitotrol 100, type UTDB

- (A) Vitotrol 100, type UTDB
- (B) Terminals "X1/96" on the control unit
- (C) Jumper; remove when making this connection.

Recommended connecting cable

- 2-core cable with a cross-section of 1.5 mm² for 230 V~

Power supply

Regulations and directives

⚠ Danger
Incorrectly executed electrical installations can result in injuries from electrical current and damage to the appliance.

Connect the power supply and implement all safety measures (e.g. RCD circuit) in accordance with the following regulations:

- VDE regulations
- Connection requirements specified by your local power supply utility

Install an isolator in the power cable to provide omnipolar separation from the mains for all active conductors, corresponding to overvoltage category III (3 mm) for complete isolation. The isolator must be fitted in the permanent electrical installation, in line with installation requirements.

We also recommend installing an AC/DC-sensitive RCD (RCD class B ) for DC (fault) currents that can occur with energy efficient equipment.

If the power supply to the appliance is connected with a flexible cable, ensure that the live conductors are pulled taut before the earth conductor in the event of strain relief failure. The length of the earth conductor wire will depend on the design.

Protect the power cable with a fuse/MCB of up to 16 A.

⚠ Danger
Incorrect core assignment can result in serious injury and damage to the appliance. Take care **not** to interchange wires "L1" and "N".

⚠ Danger
The absence of component earthing for the system can lead to serious injury from electric current if an electrical fault occurs. The appliance and pipework must be connected to the equipotential bonding of the building.

Routing cables/leads and closing the control unit enclosure

! Please note
Connecting cables/leads will be damaged if they touch hot components. When routing and securing cables/leads on site, ensure that the maximum permissible temperature for these is not exceeded.

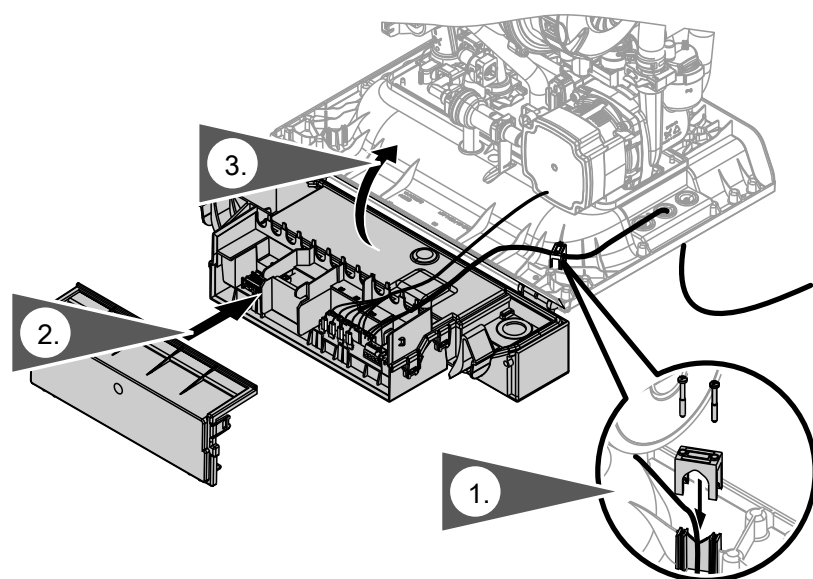
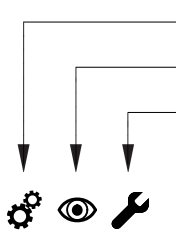

Fig. 17



Steps - commissioning, inspection and maintenance



Commissioning steps
 Inspection steps
 Maintenance steps

Page

•	•	•	1. Filling the heating system	24
•	•	•	2. Venting the boiler by flushing	25
•	•	•	3. Changing the gas type	26
•	•	•	4. Checking the static pressure and supply pressure	27
•			5. Reducing the maximum heating output	28
•			6. Matching the circulation pump rate to the heating system	29
•			7. Matching the burner output to the flue system	29
•			8. Burner adjustment when connecting multiple flues to a shared flue system	30
•			9. Adjusting the burner settings if several boilers are connected to a shared flue (flue gas cascade)	36
•			10. Checking the CO₂ content	39
	•	•	11. Removing the burner	40
	•	•	12. Checking the burner gasket and burner gauze assembly	40
	•	•	13. Checking and adjusting the electrode	41
	•	•	14. Cleaning the heat exchanger	42
	•	•	15. Checking the condensate drain and cleaning the trap	43
	•	•	16. Installing the burner	43
	•	•	17. Checking the diaphragm expansion vessel and system pressure	44
•	•	•	18. Checking all connections on the heating water and DHW sides for leaks	
•	•	•	19. Checking the flue system for unrestricted flow and tightness	
•	•	•	20. Checking the firm seating of electrical connections	
•	•	•	21. Checking all gas equipment for tightness at operating pressure	45
	•	•	22. Mounting the front panel	45
•			23. Setting the DHW comfort function	45
•			24. Setting display backlighting for standby	46
•			25. Adjusting the display contrast	46
•			26. Setting the signal tone for display operation	46
•			27. Instructing the system user	47





Filling the heating system

According to EN 1717, as a heat transfer medium for DHW heating, the heating water must meet fluid category ≤ 3 . This requirement is met if water of potable quality is used as heating water. For example, if additives are used, the additive manufacturer must specify which category the treated heating water comes under.

1. Close the gas shut-off valve.
2. Switch ON the power supply.

Information on automatic testing of the flue gas temperature sensor

The control unit automatically checks the function of the flue gas temperature sensor as soon as the power supply is switched on.

Whilst this happens, the internal circulation pump is briefly switched off.

*During the test, also switch off **all** external circulation pumps in the system.*

If the flue gas temperature sensor is positioned incorrectly, commissioning is cancelled and fault message A3 is displayed (see "Repairs").

3. Tap **MODE**.
4. ▲/▼ repeatedly until **CONF** flashes.



Please note

Unsuitable fill water increases the level of deposits and corrosion and may lead to boiler damage.

- Flush the heating system thoroughly before filling.
 - Only fill with water of potable quality.
 - Fill water with a hardness above 300 ppm must be softened.
 - Special antifreeze suitable for heating systems can be added to the fill water.
5. **OK** to confirm.
"P" is displayed in the l.h. display area. The r.h. display area flashes.
 6. Use ▲/▼ to select "12".
 7. **OK** to confirm.
"1" flashes in the l.h. display area.
 8. **OK** to confirm.
"0" flashes in the r.h. display area.
 9. Use ▲/▼ to select "1".
 10. **OK** to confirm.
Filling is activated. The boiler circuit pump is running; the 3-way diverter valve moves to its centre position. This function terminates automatically after 30 min or when the ON/OFF switch is turned off.



Filling the heating system (cont.)

Gas condensing system boiler

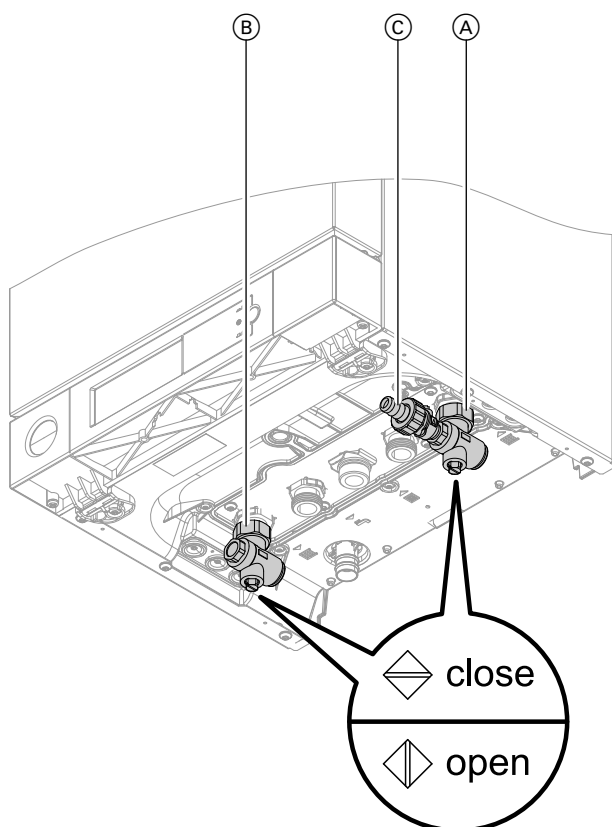

1. Open shut-off valves (A) and (if fitted) (B).
2. Connect fill hose to valve (C) and open valve (C).
3. Fill the heating system. Minimum system pressure ≥ 0.8 bar (80 kPa).
4. Close valve (C).

Fig. 18

Gas condensing combi boiler

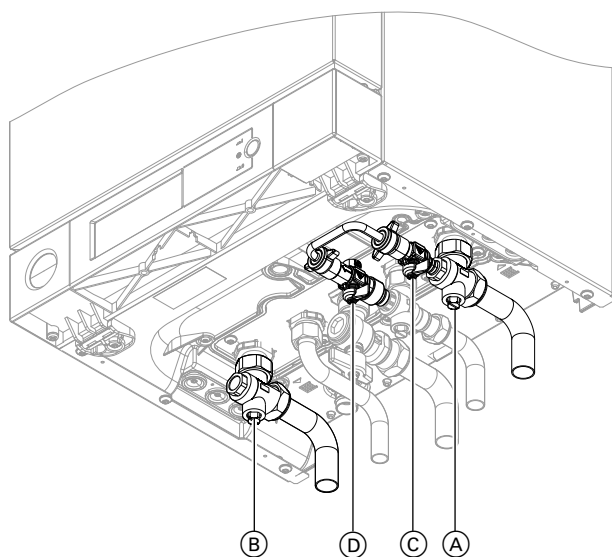

1. Open shut-off valves (A) and (if fitted) (B).
 2. Open valves (C) and (D).
- Note**
The cold water supply must be open.
3. Fill the heating system. Minimum system pressure ≥ 0.8 bar (80 kPa).
 4. Close valves (C) and (D).
 5. Remove the connection line between valves (C) and (D). During operation, the connection **must** be interrupted.

Fig. 19



Venting the boiler by flushing

Note

Inadequate venting can result in damage due to steam blasts in the heat exchanger.

   **Venting the boiler by flushing** (cont.)

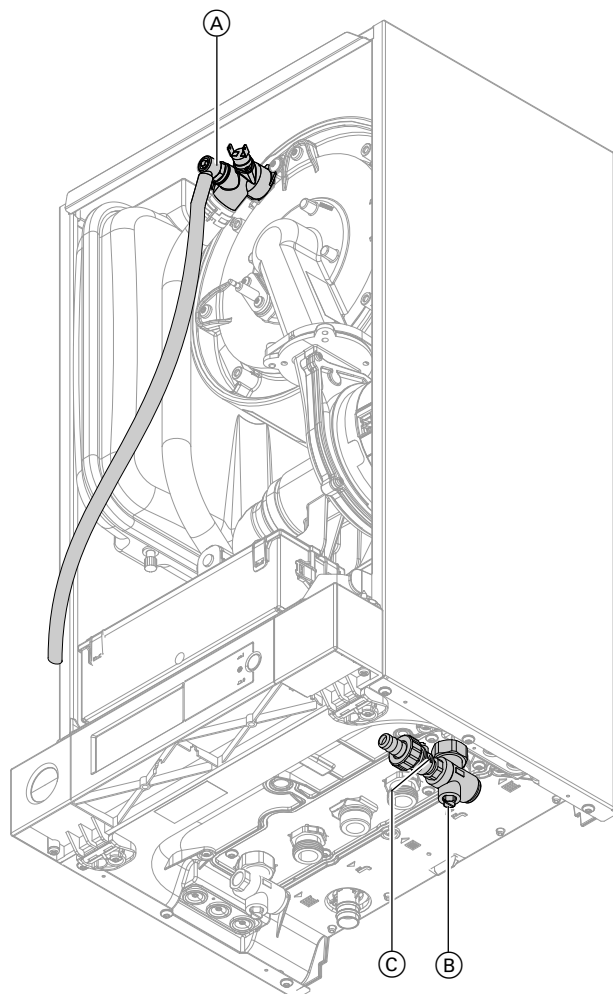

1. Connect the drain hose fitted at shut-off valve (A) to a drain connection.
2. Close shut-off valve (B).
3. Open valves (A) and (C) and flush at mains pressure until no sound of escaping air can be heard.
4. First close valve (A) and then valve (C).
5. Adjust the operating pressure ≥ 0.8 bar (80 kPa) with valve (C).
6. Open shut-off valve (B).
7. Disconnect drain hose and keep safe.

Fig. 20

   **Changing the gas type**

In the delivered condition, the boiler is set up for operation with natural gas (G20). For operation with a different gas type, install a conversion kit and change the gas type at the control unit.

Enter the selected gas type and the associated limits for flue gas emissions in the table below.

 Separate installation instructions

 For values, see separate installation instructions.

Selected gas type

	Gas type	Date	CO ₂ content in %	O ₂ content in %	CO content in ppm
Delivered condition	G20		7.5 - 10.5		< 1000
Changed to					< 1000
Changed to					< 1000



Checking the static pressure and supply pressure

Danger
 CO formation as a result of incorrect burner adjustment can have serious health implications. Check the CO content before and after carrying out work on gas appliances.

Operation with LPG

Purge the LPG tank twice on commissioning or replacement. Vent the tank and gas connection line thoroughly after purging.

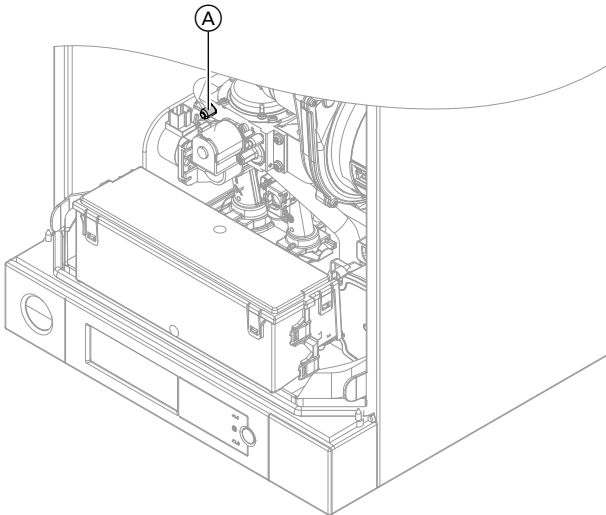

Fig. 21

1. Close the gas shut-off valve.
2. Undo screw (A) inside test connector "IN" on the gas train but do not remove it, and connect the pressure gauge.
3. Open the gas shut-off valve.
4. Check the static pressure.

Set value:

- Natural gas: 20 mbar (2.0 kPa)
- LPG: 37 mbar (3.7 kPa)

5. Start the boiler.

Note

During commissioning, the appliance can enter a fault state because of airlocks in the gas line. After approx. 5 s, tap and hold "R" for approx. 2 s to reset the burner.

Ensure that enough heat is being drawn during the testing and setting processes.

6. Check the supply (flow) pressure.
 Set value: see type plate.

Note

Use a suitable tester with a resolution of at least 0.1 mbar (10 Pa) to check the supply pressure.

7. Implement measures as indicated in the table below.
8. Shut down the boiler, close the gas shut-off valve, remove the pressure gauge and close test connector (A) with the screw.
9. Open the gas shut-off valve and start the appliance.



Danger

Gas escaping from the test connector leads to a risk of explosion.

Check gas tightness at test connector (A).

Note

The maximum pressure drop between the gas shut-off valve and test connector (A) at the gas train is 0.5 mbar (50 Pa).

Supply pressure (flow pressure)		Steps
For natural gas	For LPG	
Below 10 mbar (1.0 kPa)	Below 25 mbar (2.5 kPa)	Do not commission the boiler. Notify the gas supply utility or LPG supplier.
10 to 33 mbar (1.0 to 3.3 kPa)	25 to 57.5 mbar (2.5 to 5.75 kPa)	Start the boiler.
Above 33 mbar (3.3 kPa)	Above 57.5 mbar (5.75 kPa)	Connect a separate gas pressure governor upstream of the system and set it to the nominal pressure (see type plate). Notify the gas supply utility or LPG supplier.



Reducing the maximum heating output

The maximum heating output can be reduced according to the system requirements.

1. Tap **MODE**.
 2. ▲/▼ repeatedly until **CONF1** flashes.
 3. **OK** to confirm
"P" is displayed in the l.h. display area. The r.h. display area flashes.
 4. Use ▲/▼ to select "12".
 5. **OK** to confirm
"1" flashes in the l.h. display area.
 6. Use ▲/▼ to select "2".
 7. **OK** to confirm
The value of the selected maximum heating output, in % of the upper heating output, flashes in the r.h. display area.
 8. Use ▲/▼ to select the required max. heating output. See the table below.
- Note**
The values are based on natural gas G20. Balanced flue pipe Ø 60/100 mm, 1 m long.
9. **OK** to confirm. The selected value is adopted.
 10. Check the selected heating output by measuring the gas throughput.

Heating output in kW	Setting in %		
	Rated heating output in kW		
	19	26	30 and 35
26	—	80	67
25	—	77	64
24	—	74	62
23	—	71	59
22	—	68	56
21	—	65	54
20	—	61	51
19	58	58	49
18	55	55	46
17	52	52	44
16	49	49	41
15	46	46	38
14	43	43	36
13	40	40	33
12	37	37	31
11	34	34	28
10	31	31	26
9	28	28	23
8	25	25	20
7	22	22	18
6	19	19	15
5	15	15	—

Heating output in kW	Setting in %		
	Rated heating output in kW		
	19	26	30 and 35
35	—	—	90
34	—	—	87
33	—	—	85
32	—	—	82
31	—	—	80
30	—	—	77
29	—	—	74
28	—	—	72
27	—	—	69



Matching the circulation pump rate to the heating system

In its delivered condition the circulation pump rate is set to the following values:

- For DHW heating: speed 100 %
- For heating mode without outside temperature sensor:

Rated heating output in kW	19	26	30	35
Speed in %	72	80	86	100

The speed cannot be changed.

- For heating mode with outside temperature sensor:

Rated heating output in kW	19	26	30	35
Min. speed in %	72	72	72	72
Max. speed in %	72	80	86	100

The maximum speed can be changed. See the following chapter.

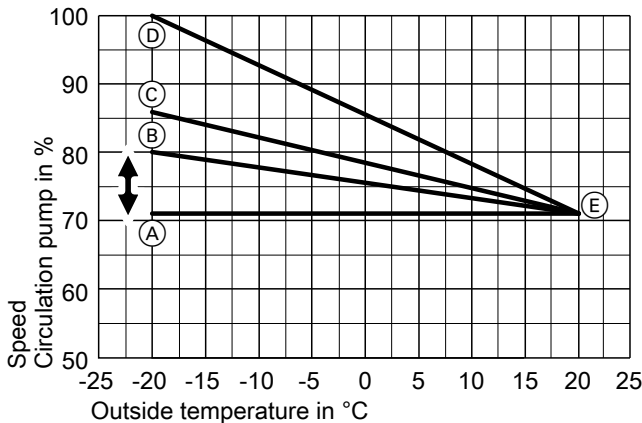

Fig. 22

- (A) Max. speed 19 kW
- (B) Max. speed 26 kW
- (C) Max. speed 30 kW
- (D) Max. speed 35 kW
- (E) Min. speed

Changing the maximum speed

Only when operating with an outside temperature sensor.

1. Tap **MODE**.
2. ▲/▼ repeatedly until **CONF1** flashes.
3. **OK** to confirm.
"P" is displayed in the l.h. display area. The r.h. display area flashes.
4. Use ▲/▼ to select "12".
5. **OK** to confirm.
"1" flashes in the l.h. display area.
6. Use ▲/▼ to select "6".
7. **OK** to confirm.
The selected max. speed in % will flash in the r.h. display area.
8. Use ▲/▼ to change the speed value.
Max. speed and setting range are subject to appliance-specific parameters.
9. **OK** to confirm. The selected value is adopted.



Matching the burner output to the flue system

To match the burner output to the system flue pipe length, a correction factor can be set.

1. Tap **MODE**.
2. ▲/▼ repeatedly until **CONF1** flashes.
3. **OK** to confirm.
"P" is displayed in the l.h. display area. The r.h. display area flashes.
4. Use ▲/▼ to select "12".



Matching the burner output to the flue system (cont.)

5. **OK** to confirm.
"1" flashes in the l.h. display area.
6. Use ▲/▼ to select "3".
7. **OK** to confirm.
The selected correction factor flashes in the r.h. display area.
8. Refer to the following table for the correction factor required for the connected flue system.
9. Use ▲/▼ to change the correction factor.
10. **OK** to confirm. The selected value is adopted.

Correction factor		0	1	2	3	4	5	6
Flue system	Rated heating output (kW)	Max. pipe length (m)						
Open flue operation Ø 60 mm	19	3	9	15	—	—	—	—
	26	3	12	15	—	—	—	—
	30	5	9	15	21	25	—	—
	35	4	9	15	22	25	—	—
Room sealed operation Ø 60/100 mm coaxial	19	2	5	9	15	20	—	—
	26	2	6	11	16	20	—	—
	30	3	5	8	12	16	20	25
	35	2	5	8	12	16	25	—
Open flue operation Ø 80 mm	19	7	25	—	—	—	—	—
	26	16	25	—	—	—	—	—
	30	17	25	—	—	—	—	—
	35	11	25	—	—	—	—	—
Room sealed operation Ø 80/125 mm coaxial	19	2	10	18	25	—	—	—
	26	5	20	25	—	—	—	—
	30	7	13	22	25	—	—	—
	35	5	13	22	25	—	—	—



Burner adjustment when connecting multiple flues to a shared flue system

When connecting several Vitodens 100-W to a common flue system:
Adjust the burner settings of each connected boiler by a correction factor to match them to the flue system.

System conditions:

- Shared flue in shaft Ø 100 mm
- Balanced flue connection pipe from boiler to shaft, Ø 80/125 mm

1. Tap **MODE**.
2. ▲/▼ until **CONFI** flashes.
3. **OK** to confirm.
"P" appears in the l.h. display area. The r.h. display area flashes.
4. Use ▲/▼ to select "12".
5. **OK** to confirm.
"1" flashes in the l.h. display area.
6. Use ▲/▼ to select "4".
7. **OK** to confirm.
"0" flashes in the r.h. display area.
8. Refer to the following tables for the correction factor required for the flue system.



Burner adjustment when connecting multiple... (cont.)

9. Use ▲▼ to set the correction factor.

One boiler per floor

10. **OK** to confirm. The selected value is adopted.

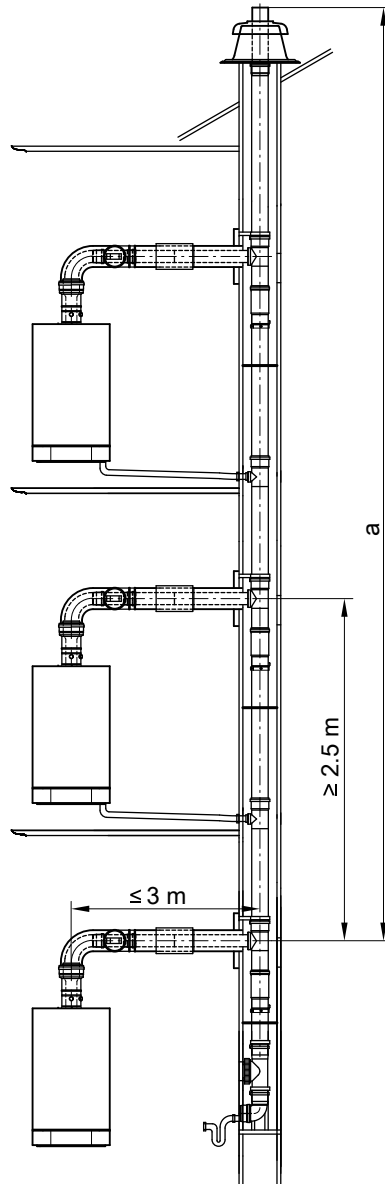

Fig. 23

Rated heating output 19 kW – operation with natural gas

Number of boilers	2	3	4	5	6
Correction factor (adjustable value)	Flue length a (m)				
0					
3	≤ 25	≤ 13	≤ 10		
4	–	> 13 ≤ 25	> 10 ≤ 19	≤ 16	≤ 14
5	–	–	> 19 ≤ 25	> 16 ≤ 25	> 14 ≤ 21
6	–	–	–	–	> 21 ≤ 25

**Rated heating output 19 kW – operation with LPG**

Number of boilers	2	3	4	5	6
Correction factor (adjustable value)	Flue length a (m)				
0					
3	≤ 25	≤ 20	≤ 13	≤ 12	
4	–	> 20 ≤ 25	> 13 ≤ 23	> 12 ≤ 18	≤ 15
5	–	–	> 23 ≤ 25	> 18 ≤ 25	> 15 ≤ 20
6	–	–	–	–	> 20 ≤ 25

Rated heating output 26 kW – operation with natural gas

Number of boilers	2	3	4	5	6
Correction factor (adjustable value)	Flue length a (m)				
0					
3	≤ 18	≤ 9			
4	> 18 ≤ 25	> 9 ≤ 21	≤ 13	≤ 12	
5	–	> 21 ≤ 25	> 13 ≤ 23	> 12 ≤ 18	≤ 16
6	–	–	> 23 ≤ 25	> 18 ≤ 25	> 16 ≤ 25

Rated heating output 26 kW – operation with LPG

Number of boilers	2	3	4	5	6
Correction factor (adjustable value)	Flue length a (m)				
0					
3	≤ 25	≤ 12	≤ 10		
4	–	> 12 ≤ 25	> 10 ≤ 16	≤ 13	
5	–	–	> 16 ≤ 23	> 13 ≤ 17	≤ 15
6	–	–	> 23 ≤ 25	> 17 ≤ 25	> 15 ≤ 25

Rated heating output 30 kW – operation with natural gas

Number of boilers	2	3	4	5	6
Correction factor (adjustable value)	Flue length a (m)				
0					
1	≤ 25	≤ 11	≤ 8		
2	–	> 11 ≤ 25	> 8 ≤ 17	≤ 14	≤ 13
3	–	–	> 17 ≤ 24	> 14 ≤ 18	> 13 ≤ 16
4	–	–	> 24 ≤ 25	> 18 ≤ 23	> 16 ≤ 19
5	–	–	–	> 23 ≤ 25	> 19 ≤ 25
6	–	–	–	–	–

Rated heating output 30 kW – operation with LPG

Number of boilers	2	3	4	5	6
Correction factor (adjustable value)	Flue length a (m)				
0					
1	≤ 25	≤ 12	≤ 9		
2	–	> 12 ≤ 25	> 9 ≤ 16	≤ 13	
3	–	–	> 16 ≤ 22	> 13 ≤ 17	≤ 15

Burner adjustment when connecting multiple... (cont.)

Number of boilers	2	3	4	5	6
Correction factor (adjustable value)	Flue length a (m)				
4	–	–	> 22 ≤ 25	> 17 ≤ 22	> 15 ≤ 19
5	–	–	–	> 22 ≤ 25	> 19 ≤ 22
6	–	–	–	–	> 22 ≤ 25

Rated heating output 35 kW – operation with natural gas

Number of boilers	2	3	4	5	6
Correction factor (adjustable value)	Flue length a (m)				
0					
3	≤ 19	≤ 9			
4	> 19 ≤ 25	> 9 ≤ 21	≤ 13	≤ 12	
5	–	> 21 ≤ 25	> 13 ≤ 18	> 12 ≤ 15	≤ 14
6	–	–	> 18 ≤ 25	> 15 ≤ 25	> 14 ≤ 23

Rated heating output 35 kW – operation with LPG

Number of boilers	2	3	4	5	6
Correction factor (adjustable value)	Flue length a (m)				
0					
3	≤ 22	≤ 10			
4	> 22 ≤ 25	> 10 ≤ 20	≤ 13	≤ 12	
5	–	> 20 ≤ 25	> 13 ≤ 17	> 12 ≤ 14	
6	–	–	> 17 ≤ 25	> 14 ≤ 24	≤ 20

Note

The correction factor changes the boiler modulation range.



2 boilers per floor

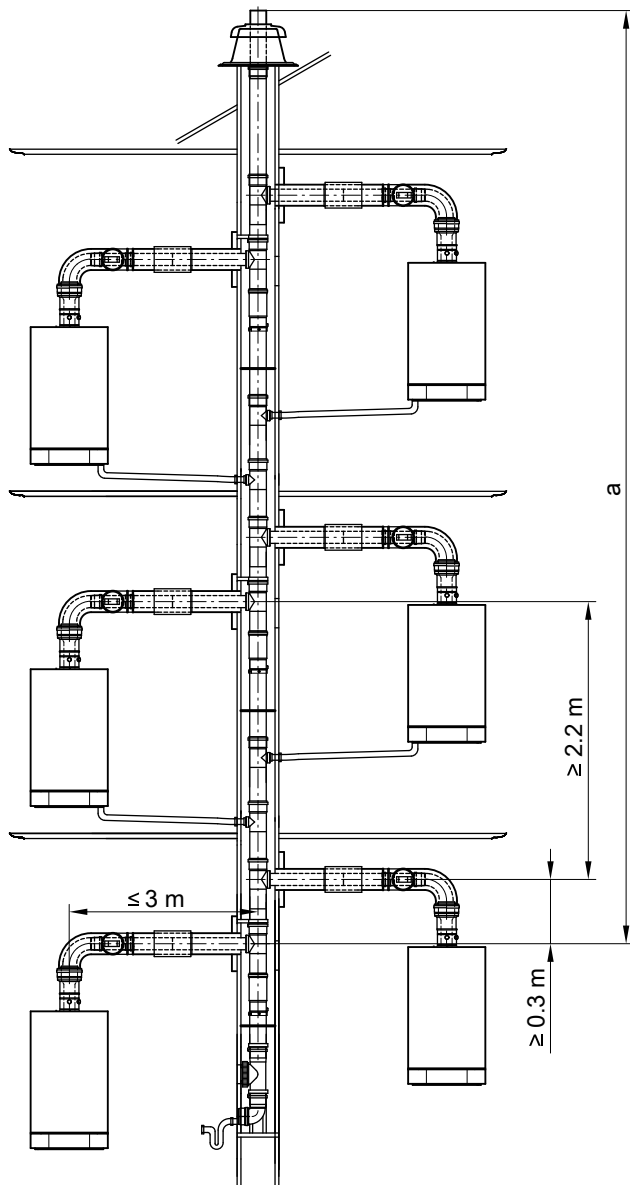

Fig. 24

Rated heating output 19 kW – operation with natural gas

Number of boilers	2	4	6
Correction factor (adjustable value)	Flue length a (m)		
0			
3	≤ 25	≤ 6	
4	–	> 6 ≤ 16	≤ 9
5	–	> 16 ≤ 25	> 9 ≤ 16
6	–	–	> 16 ≤ 25

Rated heating output 19 kW – operation with LPG

Number of boilers	2	4	6
Correction factor (adjustable value)	Flue length a (m)		
0			
3	≤ 25	≤ 9	≤ 7

Burner adjustment when connecting multiple... (cont.)

Number of boilers	2	4	6
Correction factor (adjustable value)	Flue length a (m)		
4	–	> 9 ≤ 20	> 7 ≤ 11
5	–	> 20 ≤ 25	> 11 ≤ 15
6	–	–	> 15 ≤ 25

Rated heating output 26 kW – operation with natural gas

Number of boilers	2	4	6
Correction factor (adjustable value)	Flue length a (m)		
0			
3	≤ 16	≤ 4	
4	> 16 ≤ 25	> 4 ≤ 10	≤ 7
5	–	> 10 ≤ 20	> 7 ≤ 11
6	–	> 20 ≤ 25	> 11 ≤ 24

Rated heating output 26 kW – operation with LPG

Number of boilers	2	4	6
Correction factor (adjustable value)	Flue length a (m)		
0			
3	≤ 25	≤ 6	
4	–	> 6 ≤ 12	≤ 8
5	–	> 12 ≤ 19	> 8 ≤ 10
6	–	> 19 ≤ 25	> 10 ≤ 20

Rated heating output 30 kW – operation with natural gas

Number of boilers	2	4	6
Correction factor (adjustable value)	Flue length a (m)		
0			
1	≤ 23	≤ 5	
2	> 23 ≤ 25	> 5 ≤ 13	≤ 8
3	–	> 13 ≤ 20	> 8 ≤ 11
4	–	> 20 ≤ 25	> 11 ≤ 14
5	–	–	> 14 ≤ 19
6	–	–	> 19 ≤ 23

Rated heating output 30 kW – operation with LPG

Number of boilers	2	4	6
Correction factor (adjustable value)	Flue length a (m)		
0			
1	≤ 25	≤ 6	
2	–	> 6 ≤ 12	≤ 8
3	–	> 12 ≤ 18	> 8 ≤ 10
4	–	> 18 ≤ 25	> 10 ≤ 13
5	–	–	> 13 ≤ 17
6	–	–	> 17 ≤ 19



Burner adjustment when connecting multiple... (cont.)

Rated heating output 35 kW – operation with natural gas

Number of boilers	2	4	6
Correction factor (adjustable value)	Flue length a (m)		
0			
3	≤ 17	≤ 4	
4	> 17 ≤ 25	> 4 ≤ 10	≤ 7
5	–	> 10 ≤ 15	> 7 ≤ 8
6	–	> 15 ≤ 25	> 8 ≤ 17

Rated heating output 35 kW – operation with LPG

Number of boilers	2	4	6
Correction factor (adjustable value)	Flue length a (m)		
0			
3	≤ 20	≤ 5	
4	> 20 ≤ 25	> 5 ≤ 9	≤ 6
5	–	> 9 ≤ 14	> 6 ≤ 8
6	–	> 14 ≤ 25	> 8 ≤ 15

Note

The correction factor changes the boiler modulation range.



Adjusting the burner settings if several boilers are connected to a shared flue (flue gas cascade)

Adjust the burner settings of each connected boiler by a correction factor to match them to the flue system.

System conditions:

- Shared flue gas header \varnothing 100 mm
- Max. 4 boilers with the same rated heating output connected to the flue system

1. Tap **MODE**.
2. **▲/▼** until **CONF1** flashes.
3. **OK** to confirm.
"P" appears in the l.h. display area. The r.h. display area flashes.
4. Use **▲/▼** to select "12".
5. **OK** to confirm.
"1" flashes in the l.h. display area.
6. Use **▲/▼** to select "4".
7. **OK** to confirm.
"0" flashes in the r.h. display area.
8. Refer to the following tables for the correction factor required for the flue system.
9. Use **▲/▼** to set the correction factor.
10. **OK** to confirm. The selected value is adopted.



Adjusting the burner settings if several... (cont.)

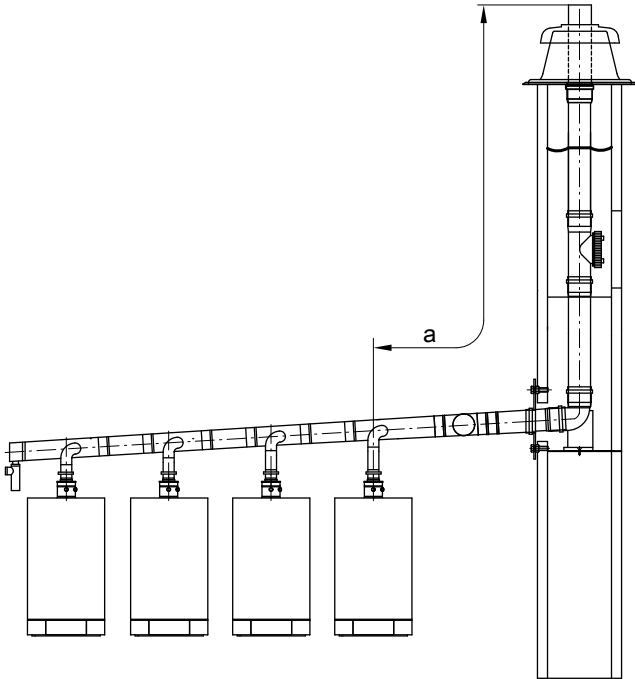

Fig. 25

Rated heating output 19 kW – operation with natural gas

Number of boilers	2	3	4
Correction factor (adjustable value)	Flue length a (m)		
0			
3	≤ 25	≤ 8	
4	–	> 8 ≤ 25	≤ 13
5	–	–	> 13 ≤ 25
6	–	–	–

Rated heating output 19 kW – operation with LPG

Number of boilers	2	3	4
Correction factor (adjustable value)	Flue length a (m)		
0			
3	≤ 25	≤ 16	≤ 6
4	–	> 16 ≤ 25	> 6 ≤ 17
5	–	–	> 17 ≤ 25
6	–	–	–

Rated heating output 26 kW – operation with natural gas

Number of boilers	2	3	4
Correction factor (adjustable value)	Flue length a (m)		
0			
3	≤ 16	≤ 4	
4	> 16 ≤ 25	> 4 ≤ 16	≤ 6
5	–	> 16 ≤ 25	> 6 ≤ 17
6	–	–	> 17 ≤ 25



Rated heating output 26 kW – operation with LPG

Number of boilers	2	3	4
Correction factor (adjustable value)	Flue length a (m)		
0			
3	≤ 25	≤ 8	≤ 3
4	–	> 8 ≤ 21	> 3 ≤ 9
5	–	> 21 ≤ 25	> 9 ≤ 16
6	–	–	> 16 ≤ 25

Rated heating output 30 kW – operation with natural gas

Number of boilers	2	3	4
Correction factor (adjustable value)	Flue length a (m)		
0			
1	≤ 24	≤ 6	
2	> 24 ≤ 25	> 6 ≤ 23	≤ 10
3	–	> 23 ≤ 25	> 10 ≤ 17
4	–	–	> 17 ≤ 24
5	–	–	> 24 ≤ 25
6	–	–	–

Rated heating output 30 kW – operation with LPG

Number of boilers	2	3	4
Correction factor (adjustable value)	Flue length a (m)		
0			
1	≤ 25	≤ 8	
2	–	> 8 ≤ 21	≤ 9
3	–	> 21 ≤ 25	> 9 ≤ 15
4	–	–	> 15 ≤ 23
5	–	–	> 23 ≤ 25
6	–	–	–

Rated heating output 35 kW – operation with natural gas

Number of boilers	2	3	4
Correction factor (adjustable value)	Flue length a (m)		
0			
3	≤ 18	≤ 4	
4	> 18 ≤ 25	> 4 ≤ 16	≤ 6
5	–	> 16 ≤ 25	> 6 ≤ 11
6	–	–	> 11 ≤ 25

Rated heating output 35 kW – operation with LPG

Number of boilers	2	3	4
Correction factor (adjustable value)	Flue length a (m)		
0			
3	≤ 21	≤ 5	
4	> 21 ≤ 25	> 5 ≤ 15	≤ 6
5	–	> 15 ≤ 23	> 6 ≤ 10
6	–	> 23 ≤ 25	> 10 ≤ 25



Adjusting the burner settings if several... (cont.)

Note

The correction factor changes the boiler modulation range.



Checking the CO₂ content

The Vitodens 100-W is factory-set for natural gas. During commissioning or maintenance, the CO₂ and CO have to be measured at the boiler flue adaptor test port to check the flue integrity. Subject to the Wobbe index, the CO₂ content fluctuates between 7.5 % and 10.5 %. CO of up to 500 ppm during start-up is acceptable. We recommend measuring the O₂, as this value is unmistakable regarding lambda (air/gas). The O₂ content fluctuates between 7.5 % and 3.2 %. The CO/CO₂ ratio has to be less than 0.004. If the actual CO₂ or O₂ and CO values deviate from the stated range, check the balanced flue system for leaks. If the flue installation is OK, change the gas valve.

Note

Operate the appliance with uncontaminated combustion air to prevent operating faults and damage.

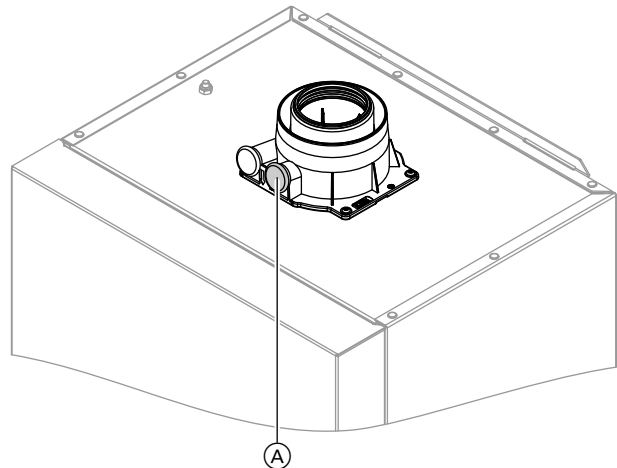

Fig. 26

1. Connect a flue gas analyser at flue gas port (A) on the boiler flue connection.
2. Start the boiler and check for leaks.



Danger

Escaping gas leads to a risk of explosion. Check all gas equipment for tightness.

3. To check the CO₂ content the burner output can be adjusted manually.
 1. Tap **MODE**.
 2. ▲/▼ repeatedly until **"SERV"** appears.
 3. **OK** to confirm. **OFF** appears on the display. Test mode is not active.
 4. Use ▲/▼ to adjust the burner output:

Shown on display	Burner output
OFF	0 %
—	20
— —	40
— — —	60
— — — —	80
— — — — —	100

5. Confirm your setting with **OK**. The bars stop flashing.

4. Check the CO₂ content for the upper heating output (100 %). For CO₂ content limits, see page 26.
5. Check the CO₂ content for the lower heating output (20 %). The CO₂ content must be between 0.5 and 0.9 % below the value of the upper heating output.
6.
 - If the CO₂ content is within the indicated range, continue with point 8.
 - If the CO₂ content is **not** within the indicated range, check the balanced flue system for tightness; remedy any leaks. Replace gas train if required.
7. Re-check the CO₂ content for the upper and lower heating output.
8. Terminate test mode:
 1. ▲/▼ repeatedly until **"SERV"** flashes.
 2. **OK** to confirm. The selected value flashes.
 3. ▼ repeatedly until **OFF** flashes.
 4. **OK** to confirm. When **"SERV"** disappears, test mode is terminated.
9. Shut down the boiler, remove the flue gas analyser and close flue gas test port (A).





Removing the burner

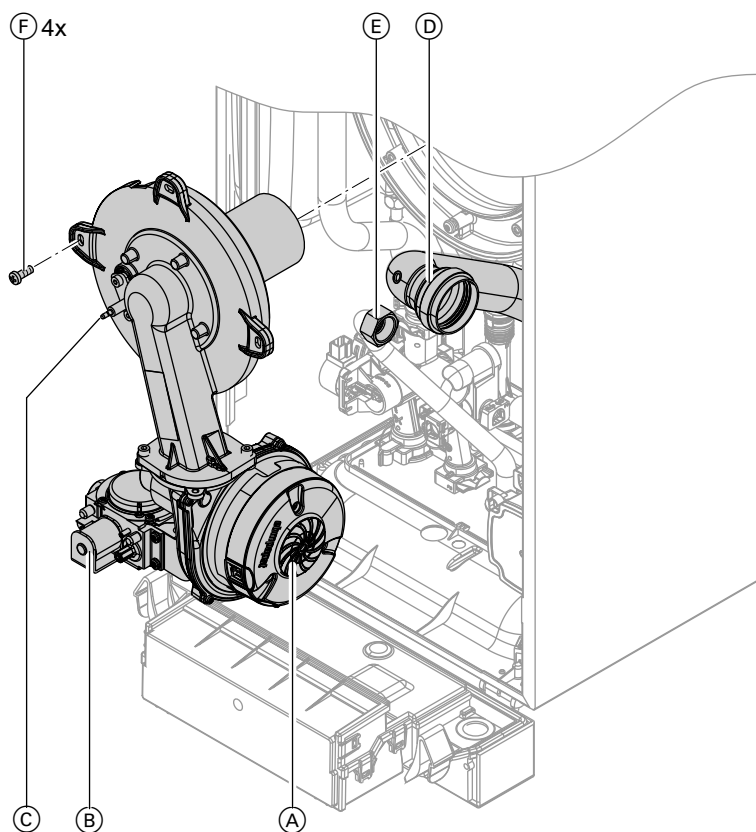

Fig. 27

1. Switch OFF the power supply.
2. Shut off the gas supply.
3. Disconnect the cables from fan motor (A), gas train (B) and electrodes (C).
4. Disconnect Venturi extension (D) from the fan.
5. Undo gas supply pipe fitting (E).
6. Undo 4 screws (F) and remove the burner.



Please note

To prevent damage, never rest the burner on the burner gauze assembly.



Checking the burner gasket and burner gauze assembly

Check burner gasket (A) for damage and replace if necessary.

Replace the burner gauze assembly if it is damaged.



Checking the burner gasket and burner gauze... (cont.)

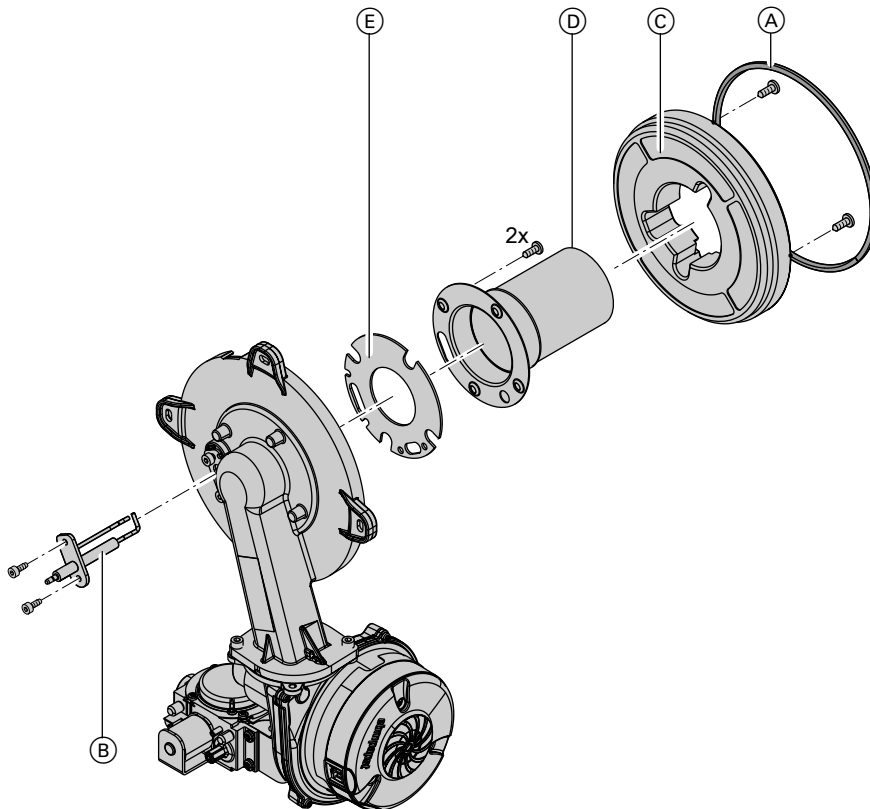

Fig. 28

1. Remove electrode (B).
2. Undo 2 Torx screws and remove thermal insulation ring (C).
3. Undo 2 Torx screws and remove burner gauze assembly (D) with gasket (E).
4. Insert and secure new burner gauze assembly (D) with new gasket (E).

! **Please note**
Tighten screws enough to ensure the components do not suffer damage and will function correctly.

5. Mount thermal insulation ring (C).

! **Please note**
Tighten screws enough to ensure the components do not suffer damage and will function correctly.

6. Fit electrode (B).

! **Please note**
Tighten screws enough to ensure the components do not suffer damage and will function correctly.



Checking and adjusting the electrode

1. Check the electrode for wear and contamination.
2. Clean the electrode with a small brush (not a wire brush) or emery paper.



Checking and adjusting the electrode (cont.)

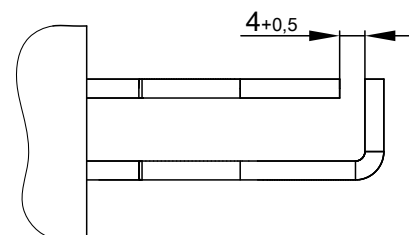
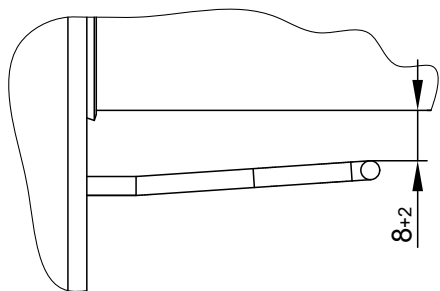

Fig. 29

3. Check the electrode gaps. If the gaps are not as specified or the electrode is damaged, replace the electrode and gasket and align.



Please note

Tighten screws enough to ensure the components do not suffer damage and will function correctly.



Cleaning the heat exchanger



Please note

Scratches to the surfaces of the heat exchanger that come into contact with hot gas can result in corrosion damage.

Never use brushes to clean the heating surfaces.



Please note

Brushing can cause deposits to become lodged in the gaps between the coils.

Never use brushes to clean the heating surfaces.

Note

Discolouration on the heat exchanger surface is a normal sign of use. It has no bearing on the function and service life of the heat exchanger.

The use of chemical cleaning agents is not required.

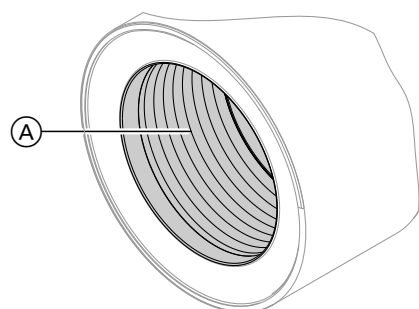

Fig. 30

1. Use a vacuum cleaner to remove combustion residues from heating surface (A) of the heat exchanger.
2. Flush heating surface (A) with water.
3. Check condensate drain and clean trap. See the following chapter.
4. Flush the heating surface again with water. This will also fill the trap with water.



Checking the condensate drain and cleaning the trap

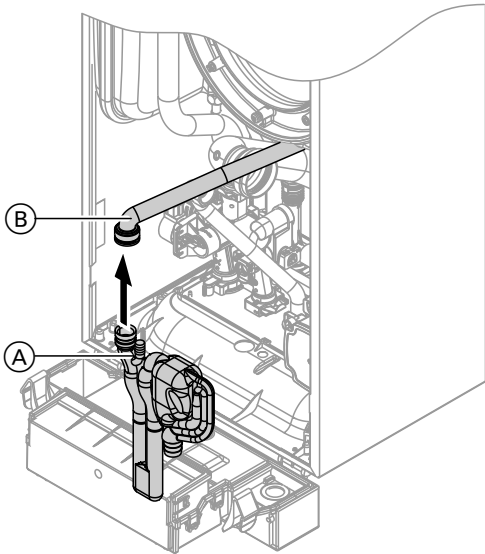

Fig. 31

1. Pull trap (A) upwards out of the drain connection.
2. Remove supply hose (B) from trap (A).
3. Clean trap (A).
4. Refit supply hose (B).
5. Refit trap (A) to the drain connection.
6. Fill trap (A) with water. For this, pour approx. 0.3 l of water into the combustion chamber.
7. Check that condensate can drain freely and that the connections are tight.



Installing the burner

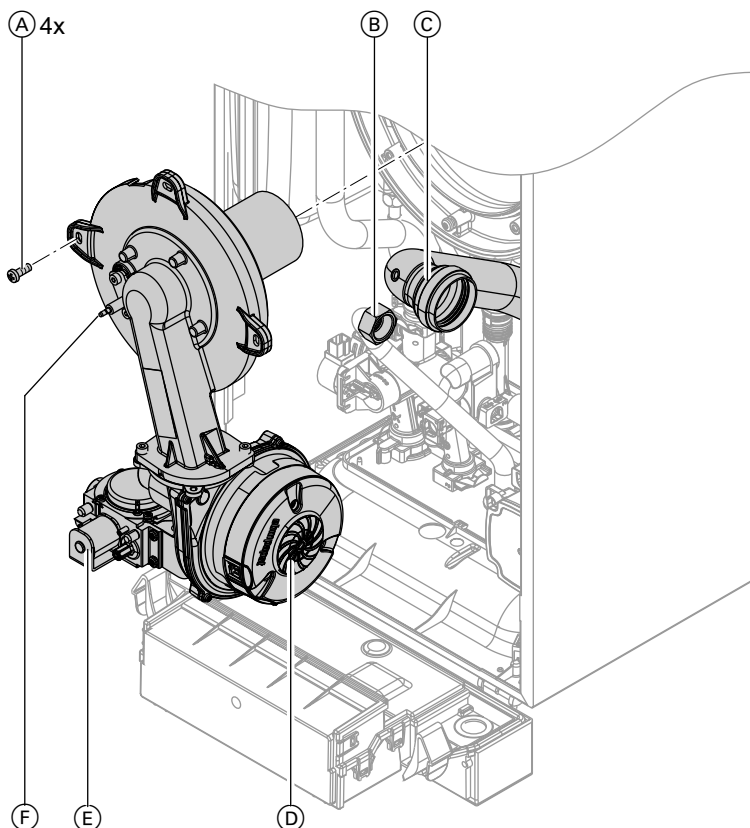

Fig. 32

1. Fit the burner and tighten 4 screws (A) diagonally.
2. Insert the new gasket and tighten the fitting on gas supply pipe (B).
3. Refit Venturi extension (C) to the fan.
4. Fit cables to fan motor (D), gas train (E) and ignition unit (F).



Please note

Tighten screws enough to ensure the components do not suffer damage and will function correctly.





Installing the burner (cont.)

5. Reopen the gas supply and switch on the power supply.

6. Check the gas connections for tightness.



Danger

Escaping gas leads to a risk of explosion. Check the fitting for gas tightness.



Please note

The use of leak detection spray can result in faulty operation. Leak detection spray must not come into contact with electrical contacts or block the diaphragm opening on the gas valve.



Checking the diaphragm expansion vessel and system pressure

Note

The expansion vessel can lose some of its charge pressure over time. When the boiler heats up, the pressure rises to 2 or 3 bar (0.2 or 0.3 MPa). The safety valve may also respond and discharge the excess pressure.

Therefore check the expansion vessel pre-charge pressure annually.

Check whether the installed expansion vessel is adequate for the system water volume. Carry out this test on a cold system.

1. Drain the system until "0" is shown on the pressure indicator.
2. If the pre-charge pressure of the expansion vessel is lower than the static system pressure: Top up with nitrogen at the valve of the diaphragm expansion vessel until the pre-charge pressure is 0.1 to 0.2 bar (10 to 20 kPa) higher than the static system pressure.
3. Top up with water until the charge pressure of the cooled system is at least 1.0 bar (0.1 MPa), and is 0.1 to 0.2 bar (10 to 20 kPa) higher than the pre-charge pressure of the expansion vessel. Permiss. operating pressure: 3 bar (0.3 MPa)

Note

The expansion vessel is supplied from the factory with a pre-charge pressure of 0.7 bar.

Do not allow the pre-charge pressure to fall below this value (boiling noises). This also applies to single floor heating systems or attic heating centres (no static pressure).

Top up with water until the charge pressure is 0.1 to 0.2 bar above the pre-charge pressure.

Note

The gas condensing combi boiler can be topped up by opening top-up valve (A).

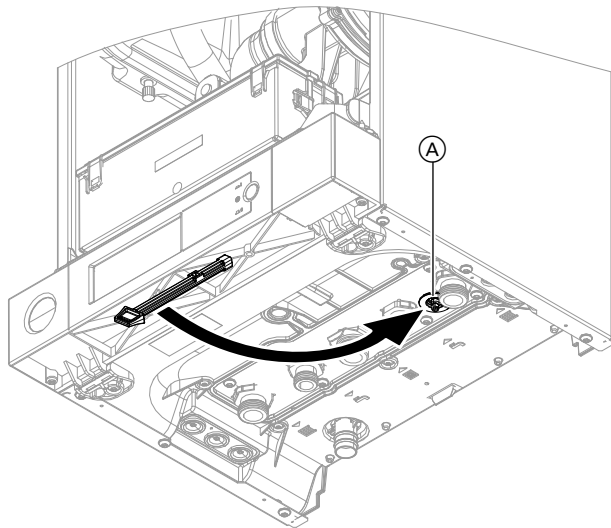

Fig. 33



Checking all connections on the heating water and DHW sides for leaks



Checking the flue system for unrestricted flow and tightness



Checking the firm seating of electrical connections



Checking all gas equipment for tightness at operating pressure



Danger
Escaping gas leads to a risk of explosion.
Check all gas equipment for tightness.



Please note
The use of leak detection spray can result in faulty operation.
Leak detection spray must not come into contact with electrical contacts or block the diaphragm opening on the gas valve.



Mounting the front panel

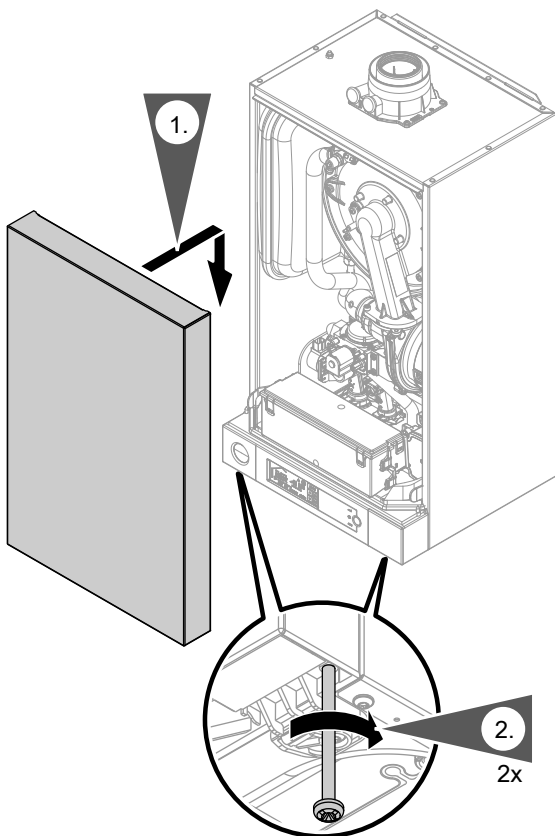

Fig. 34

1. Hook the front panel into place.
2. Tighten screws on the underside of the boiler.



Setting the DHW comfort function

Only possible for gas condensing combi boiler. The comfort function makes DHW available faster at the selected set DHW temperature.

1. Turn ON the ON/OFF switch.

2. Tap **MODE**.
3. ▲/▼ until **CONF1** flashes.





Setting the DHW comfort function (cont.)

4. **OK** to confirm.
"P" appears in the l.h. display area. The r.h. display area flashes.
5. Use ▲/▼ to select "12".
6. **OK** to confirm.
"1" flashes in the l.h. display area.
7. Use ▲/▼ to select "12".
8. **OK** to confirm.
"0" flashes in the r.h. display area.
9. Use ▲/▼ to select the comfort function.
 - "0": Without comfort function
 - or
 - "1": With comfort function
10. **OK** to confirm.



Setting display backlighting for standby

1. Turn ON the ON/OFF switch.
2. Tap **MODE**.
3. ▲/▼ until **CONFI** flashes.
4. **OK** to confirm.
"P" appears in the l.h. display area. The r.h. display area flashes.
5. Use ▲/▼ to select "12".
6. **OK** to confirm.
"1" flashes in the l.h. display area.
7. Use ▲/▼ to select "10".
8. **OK** to confirm.
"0" flashes in the r.h. display area.
9. Use ▲/▼ to select the display backlight.
 - "0": Display backlight dimmed
 - or
 - "1": Display backlight off
10. **OK** to confirm.



Adjusting the display contrast

1. Turn ON the ON/OFF switch.
2. Tap **MODE**.
3. ▲/▼ until **CONFI** flashes.
4. **OK** to confirm.
"P" appears in the l.h. display area. The r.h. display area flashes.
5. Use ▲/▼ to select "12".
6. **OK** to confirm.
"1" flashes in the l.h. display area.
7. Use ▲/▼ to select "11".
8. **OK** to confirm.
"3" flashes in the r.h. display area.
9. Use ▲/▼ to adjust the display contrast.
Adjustable from 0 to 6. The higher the value, the greater the contrast.
10. **OK** to confirm.



Setting the signal tone for display operation

1. Turn ON the ON/OFF switch.
2. Tap **MODE**.
3. ▲/▼ until **CONFI** flashes.
4. **OK** to confirm.
"P" appears in the l.h. display area. The r.h. display area flashes.
5. Use ▲/▼ to select "12".
6. **OK** to confirm.
"1" flashes in the l.h. display area.



Setting the signal tone for display operation (cont.)

7. Use ▲/▼ to select "9".
8. **OK** to confirm.
"0" flashes in the r.h. display area.
9. Use ▲/▼ to set the signal tone.
 - "0": Signal tone on
 - or
 - "1": Signal tone off
10. **OK** to confirm.



Instructing the system user

The system installer should hand the operating instructions to the system user and instruct the user in operating the system.



Changing from operation with LPG to operation with natural gas

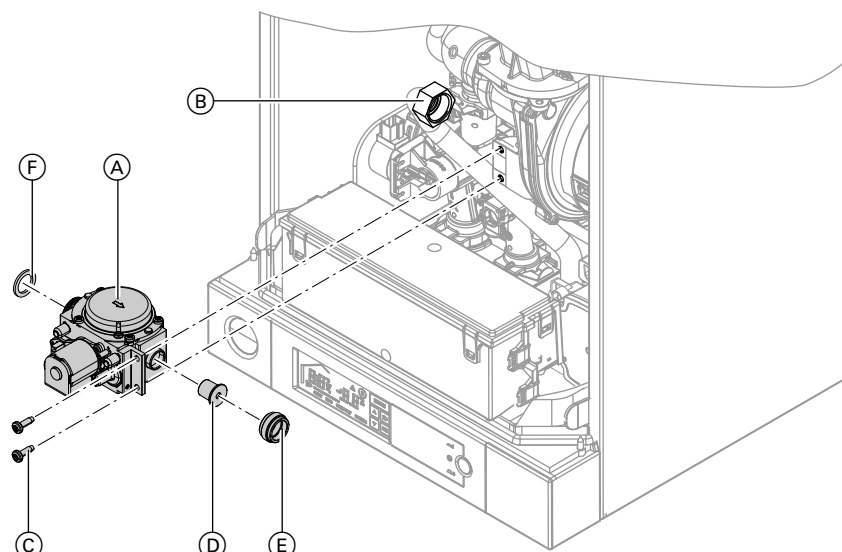

Fig. 35

1. Disconnect cable from gas train (A).
2. Undo union nut (B) and remove gas gasket.
3. Undo 2 screws (C) and remove gas train (A).
4. Remove gas restrictor (D) for LPG and gasket (E) from gas train (A).
5. Insert new gasket (E) in gas train (A).
If the gasket is missing, order the appropriate conversion kit as an individual part. See parts list (burner assembly).
6. Mount gas train (A) with new gas gasket (F).



Please note

Tighten screws enough to ensure the components do not suffer damage and will function correctly.

7. Remove or void the gas type sticker on the top of the boiler (next to the type plate).
8. Start the boiler and check for leaks.



Danger

Escaping gas leads to a risk of explosion. Check all gas equipment for tightness.



Please note

The use of leak detection spray can result in faulty operation. Leak detection spray must not come into contact with electrical contacts or block the diaphragm opening on the gas valve.

Changing the gas type at the control unit

1. Turn ON the ON/OFF switch.
2. Tap **MODE**.
3. ▲/▼ repeatedly until **CONF1** flashes.
4. **OK** to confirm.
"P" appears in the l.h. display area. The r.h. display area flashes.
5. Use ▲/▼ to select "12".
6. **OK** to confirm.
"1" flashes in the l.h. display area.
7. Use ▲/▼ to select "5".
8. **OK** to confirm.
"1" flashes in the r.h. display area.
9. Use ▲/▼ to switch the control unit to "0" (operation with natural gas).
10. **OK** to confirm.
11. Turn the ON/OFF switch OFF and ON again.
The selected operating mode is saved.

Changing from operation with LPG to operation... (cont.)

Checking the CO₂ content

See page 39.

Function sequence and possible faults

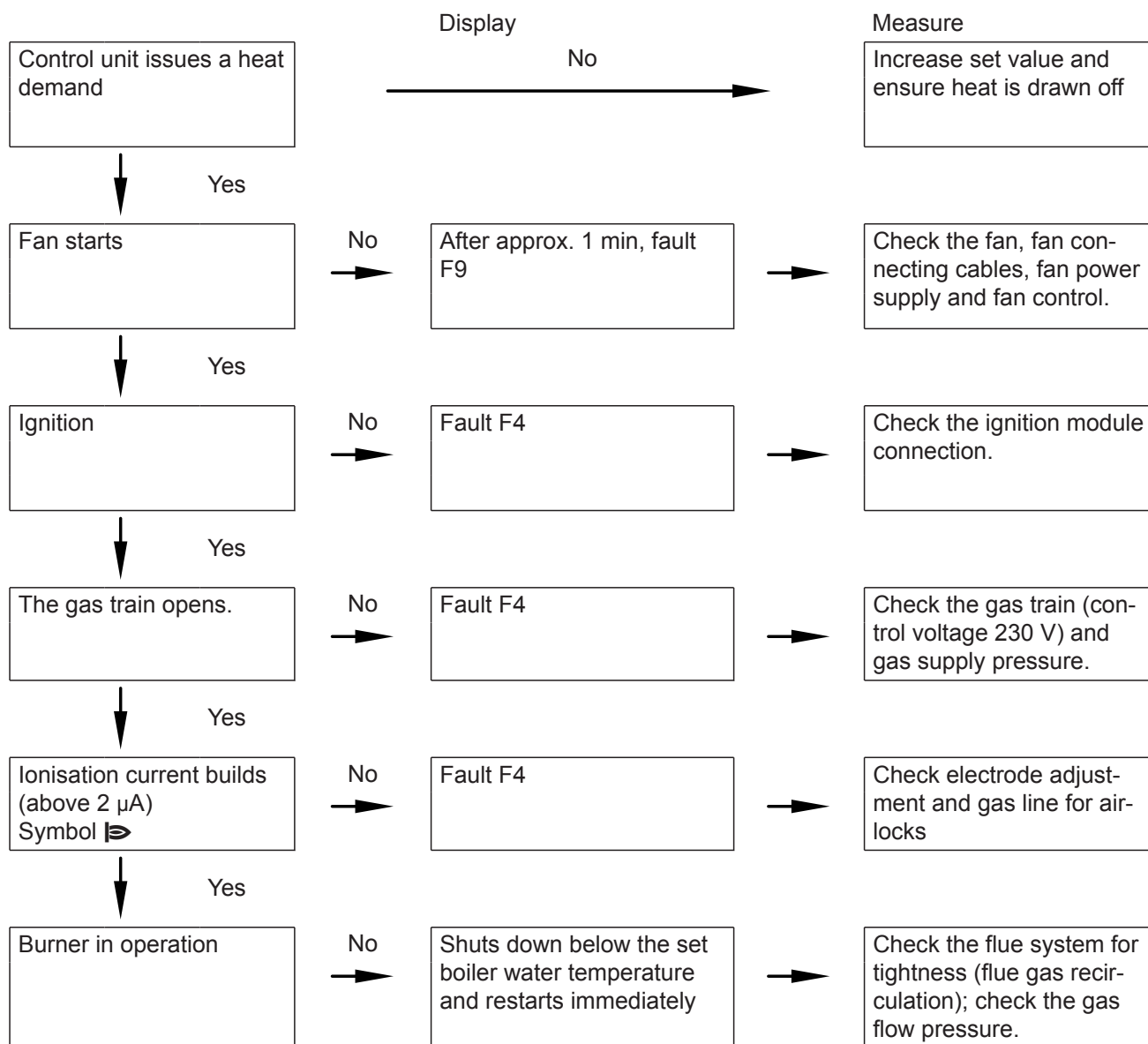

Diagnosis

Fault display

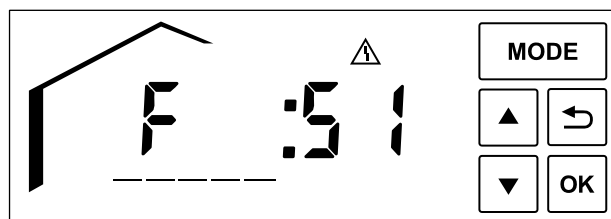



Fig. 36

In the case of a fault, the display will show  and the fault code.
 If  flashes and "R" appears, the burner is locked out. See page 52.
 For an explanation of the fault codes, see the following table.

Fault display (cont.)

Fault code displayed	System characteristics	Cause	Measures
0A	Burner blocked	CO limiter (if installed) has responded. CO concentration too high.	Check the heating system. Remove the cause of escaping CO.
0A	Burner blocked	Gas pressure switch (if installed) has responded. Gas pressure too low.	Check the gas supply.
0C	Burner blocked	Mains voltage too low	Check the power supply.
10	Continuous operation	Short circuit, outside temperature sensor	Check the outside temperature sensor and lead (see page 54).
18	Continuous operation	Lead break, outside temperature sensor	Check the outside temperature sensor and lead (see page 54).
30	Burner blocked	Short circuit, boiler water temperature sensor	Check the boiler water temperature sensor (see page 55).
38	Burner blocked	Lead break, boiler water temperature sensor	Check the boiler water temperature sensor (see page 55).
50	No DHW heating	Short circuit, cylinder temperature sensor	Check the sensor (see page 56).
51	No DHW heating	Short circuit, outlet temperature sensor	Check the sensor (see page 57).
52	Burner blocked	Short circuit, flow sensor	Check connections and lead; replace sensor if required.
58	No DHW heating	Lead break, cylinder temperature sensor	Check the sensor (see page 56).
59	No DHW heating	Lead break, outlet temperature sensor	Check the sensor (see page 57).
5A	Burner blocked	Lead break, flow sensor	Check connections and lead; replace sensor if required.
A3	Burner blocked.	Flue gas temperature sensor incorrectly positioned. No flame formation during the sensor test.	Fit flue gas temperature sensor correctly (see page 59). If necessary, repeat the test several times.
A9	Control mode without OpenTherm device	Communication error, OpenTherm device	Check connections and cable; replace OpenTherm device if necessary.
b0	Burner blocked	Short circuit, flue gas temperature sensor	Check the sensor (see page 58).
b7	Emergency mode	Burner control unit fault	Turn the ON/OFF switch off and on again.
b8	Burner blocked	Lead break, flue gas temperature sensor	Check the sensor (see page 58).
E3	Burner in a fault state	Fault in safety chain	Check the temperature limiter and connecting leads (see page 56). Check the control unit and replace if required.
E5	Burner blocked	Internal fault	Check the ionisation electrode and connecting cables. Press "Reset" (see page 52).
F0	Burner blocked.	Internal fault	Replace control unit.



Fault display (cont.)

Fault code displayed	System characteristics	Cause	Measures
F1	Burner in a fault state	Max. flue gas temperature exceeded	Check heating system fill level. Check circulation pump. Vent the system. Press "Reset" (see page 52).
F2	Burner in a fault state	Temperature limiter has responded.	Check heating system fill level. Check circulation pump. Vent the system. Check the temperature limiter and connecting leads (see page 56). Press "Reset" (see page 52).
F3	Burner in a fault state	Flame signal is already present at burner start.	Check ionisation electrode and connecting cable. Press "Reset" (see page 52).
F4	Burner in a fault state	No flame signal.	Check the ignition/ionisation electrode and connecting cable, gas pressure, gas train, ignition, ignition module and condensate drain. Press "Reset" (see page 52).
F8	Burner in a fault state	Fuel valve closes too late.	Check gas train. Check both control paths. Press "Reset" (see page 52).
F9	Burner in a fault state	Fan speed too low during burner start	Check the fan, fan connecting cables, fan power supply and fan control. Press "Reset" (see page 52).
FA	Burner in a fault state	Fan idle state not reached	Check the fan, fan connecting cables and fan control. Press "Reset" (see page 52).
FC	Burner blocked	Electrical fan control (control unit) faulty	Check fan connecting cable; replace if necessary or replace control unit.
Fd	Burner blocked	Burner control unit fault	Check ignition electrodes and connecting cables. Check whether a strong interference (EMC) field exists near the appliance. Press "Reset" (see page 52). Replace control unit if fault persists.
FF	Burner blocked	Burner control unit fault	Check ignition electrodes and connecting cables. Check whether a strong interference (EMC) field exists near the appliance. Press "Reset" (see page 52). Replace control unit if fault persists.

Press reset (reset burner control unit)

Tap and hold **R** for approx. 2 s.

If the fault has been rectified, fault symbol "△" disappears and the default display is shown or a further fault message is displayed.

If the fault persists, the fault message appears again.

Repairs

- ! Please note**
 Residual water will escape when the boiler or one of the following components is fitted or removed:
- Water-filled pipework
 - Heat exchanger
 - Circulation pumps
 - Plate heat exchanger
 - Components fitted in the heating water or DHW circuit.
- Water ingress can result in damage to other components.

- Protect the following components against ingress of water:
- Control unit components (especially in the service position)
 - Electrical components
 - Plug-in connections
 - Cables and leads

Removing the front panel

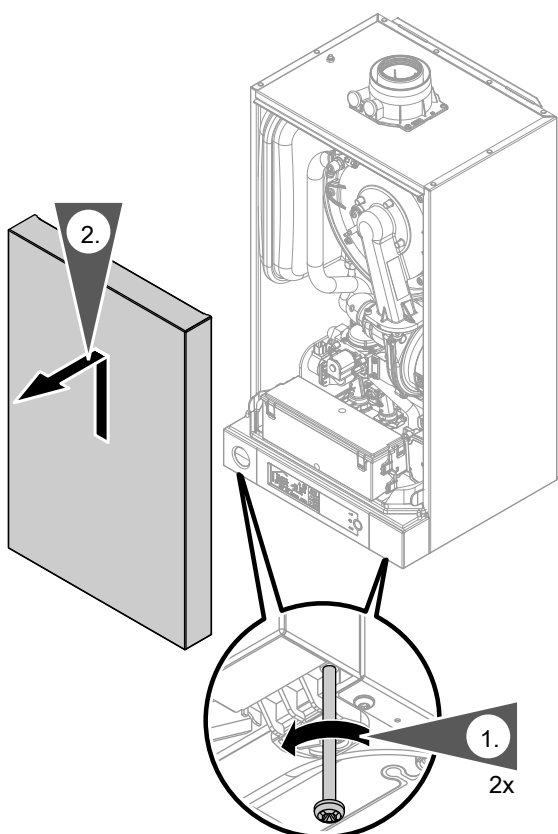

Fig. 37

1. Undo the screws on the underside of the boiler but do not remove them completely.
2. Remove front panel.

Outside temperature sensor

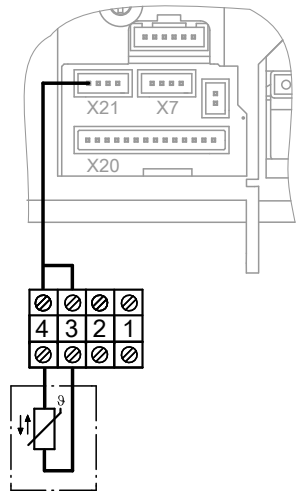

Fig. 38

1. Open the control unit enclosure. See page 18.
2. Disconnect leads from outside temperature sensor.

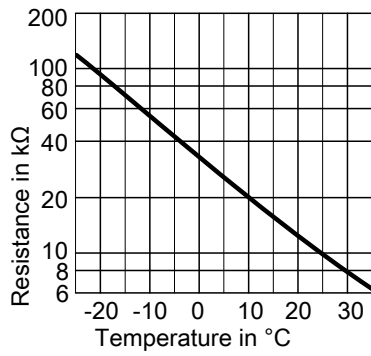

Fig. 39 Sensor type: NTC 10 kΩ

3. Check the sensor resistance and compare it to the curve.
4. In the event of severe deviation replace the sensor.

Repairs (cont.)

Boiler water temperature sensor

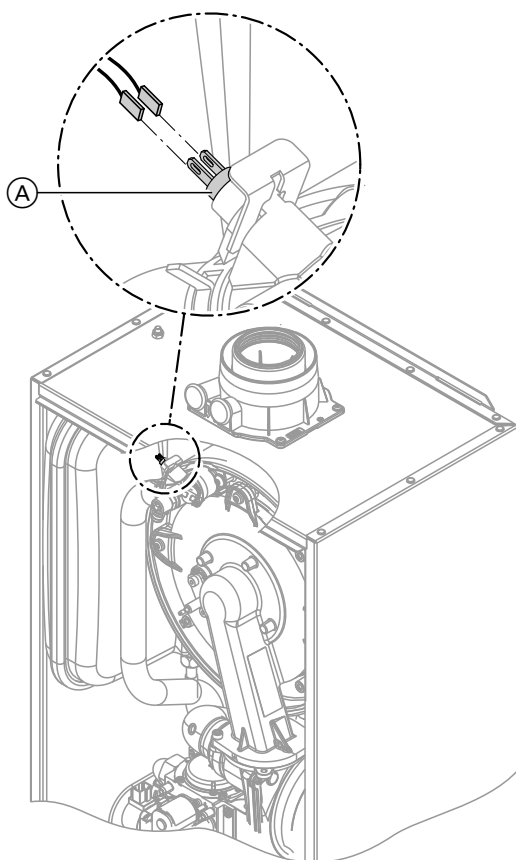

Fig. 40

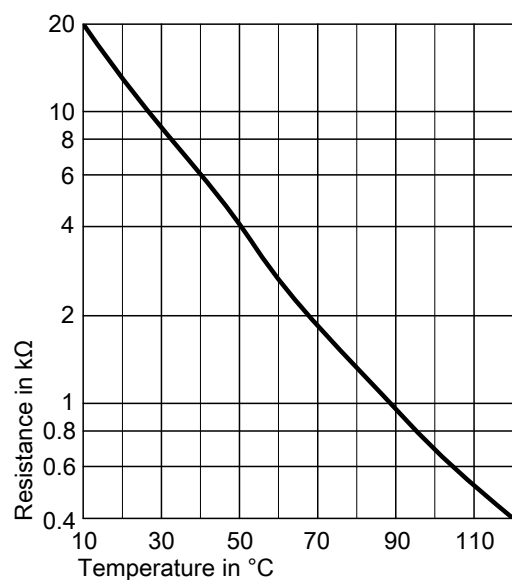

Fig. 41

1. Disconnect leads from boiler water temperature sensor (A) and check the resistance.

2. Check the sensor resistance and compare it to the curve.
3. In the case of severe deviation, drain the boiler on the heating water side and replace the sensor.



Danger

The boiler water temperature sensor is directly immersed in the heating water (risk of scalding).

Drain the boiler before replacing the sensor.

Checking the cylinder temperature sensor (gas condensing system boiler)

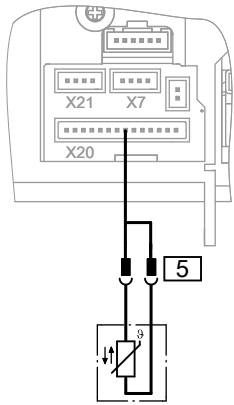

Fig. 42

1. Disconnect plug 5 from the cable harness and check the resistance.

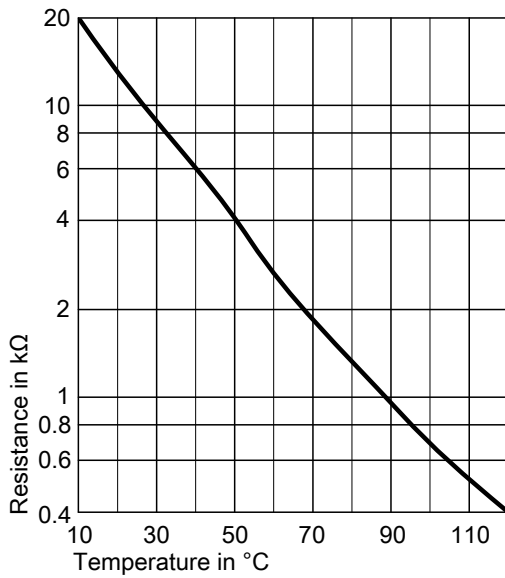

Fig. 43

2. Compare the sensor resistance to the curve.
3. In the event of severe deviation replace the sensor.

Checking the temperature limiter

If the burner control unit cannot be reset after a fault shutdown although the boiler water temperature is below approx. 95 °C, check the temperature limiter.

Repairs (cont.)

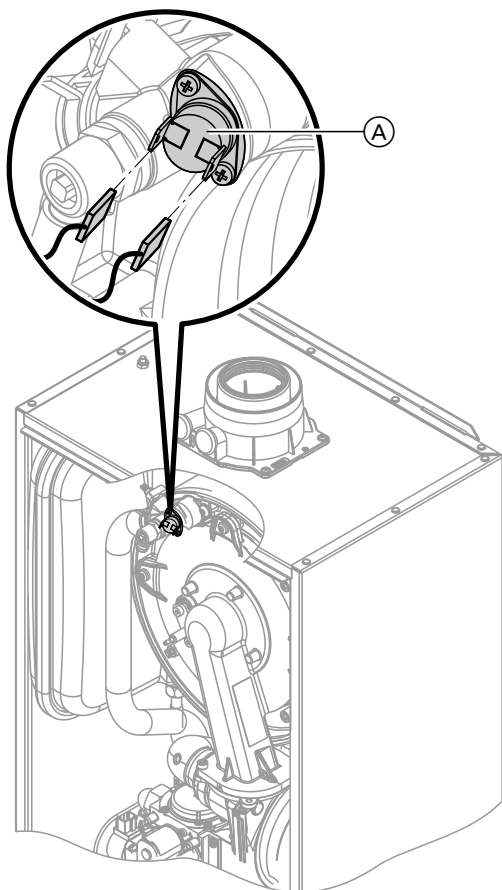

Fig. 44

1. Disconnect the leads from temperature limiter (A).
2. Check the continuity of the temperature limiter with a multimeter.
3. Remove faulty temperature limiter.
4. Install a new temperature limiter.
5. Reset by pressing "Reset" (see page 52).

Checking the outlet temperature sensor (gas condensing combi boiler)

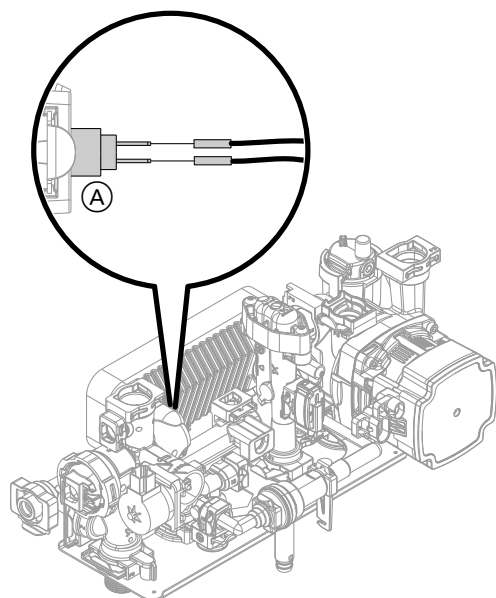

Fig. 45

1. Disconnect leads from outlet temperature sensor (A).
2. Check sensor resistance and compare it to the curve.



Repairs (cont.)

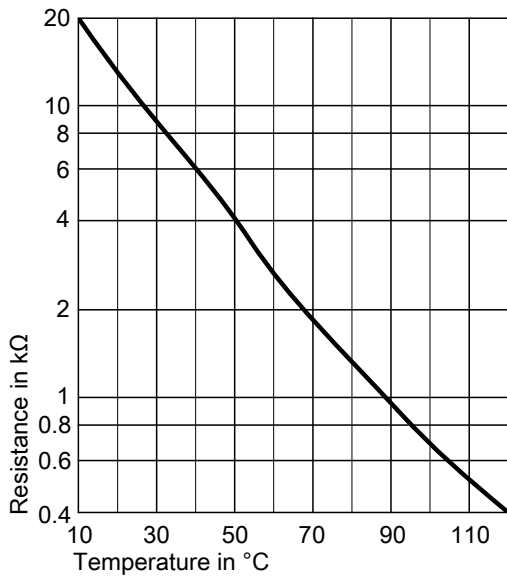

Fig. 46

- In the event of severe deviation replace the sensor.

Note

Water may escape when replacing the outlet temperature sensor. Shut off the cold water supply. Drain the DHW line and the plate heat exchanger (on the DHW side).

Checking the flue gas temperature sensor

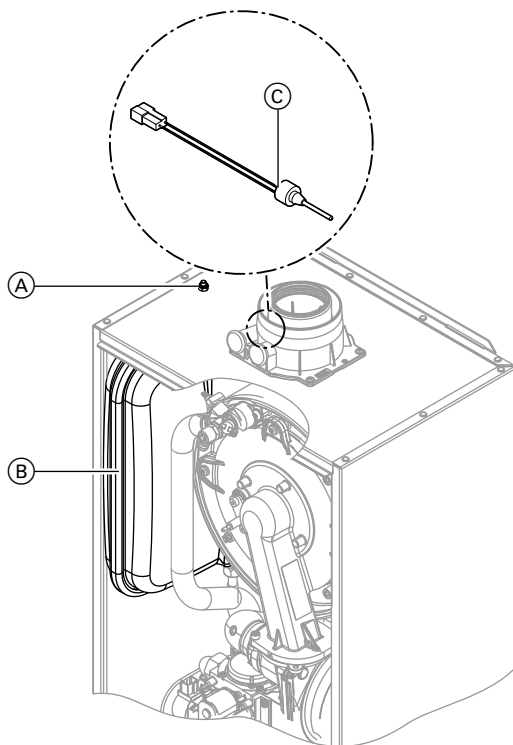

Fig. 47

- Undo nut (A) and remove expansion vessel (B).
- Disconnect leads from flue gas temperature sensor (C).
- Check sensor resistance and compare it to the curve.

Repairs (cont.)

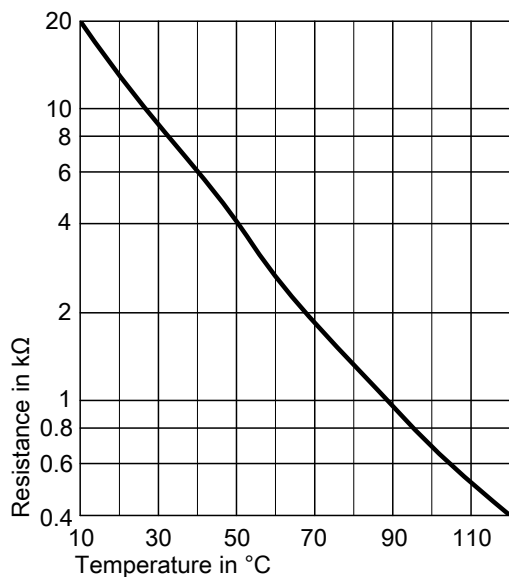

Fig. 48

Fault "A3" during commissioning

During commissioning, the control unit checks whether the flue gas temperature sensor is correctly positioned. If the flue gas temperature sensor is incorrectly positioned, commissioning is aborted and fault message A3 is shown.

1. Check whether the flue gas temperature sensor is correctly inserted. See previous diagram.
2. If necessary, correct the position of the flue gas temperature sensor or replace the faulty flue gas temperature sensor.

4. In the event of severe deviation replace the sensor.
5. Reinstall expansion vessel (B) and tighten nut (A). When installing the sensor, ensure it is correctly seated.

3. Tap and hold **R** for approx. 2 s and repeat commissioning. The check is repeated until it is completed successfully.

Note

If a stable flame is not formed during the sensor test, repeat the test several times.

Replacing the flow limiter (gas condensing combi boiler)

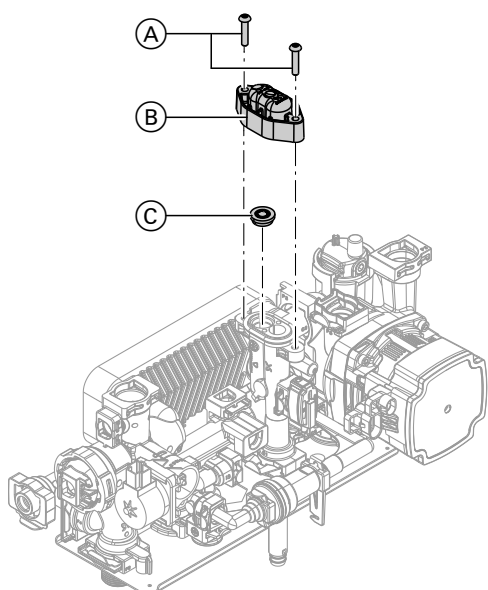

Fig. 49

1. Drain the boiler on the DHW side.
2. Pivot the control unit downwards.
3. Undo screws (A).
4. Remove cap (B).
5. Select new flow limiter (C) according to the boiler serial no. (see type plate) and the following table.
6. Insert new flow limiter (C).
7. Fit new cap (B) provided.

Serial no. (type plate)	Flow rate l/min	Colour
7570673	10	Black
7570675	12	Red
7570677	14	Brown

Checking or replacing the plate heat exchanger (gas condensing combi boiler)

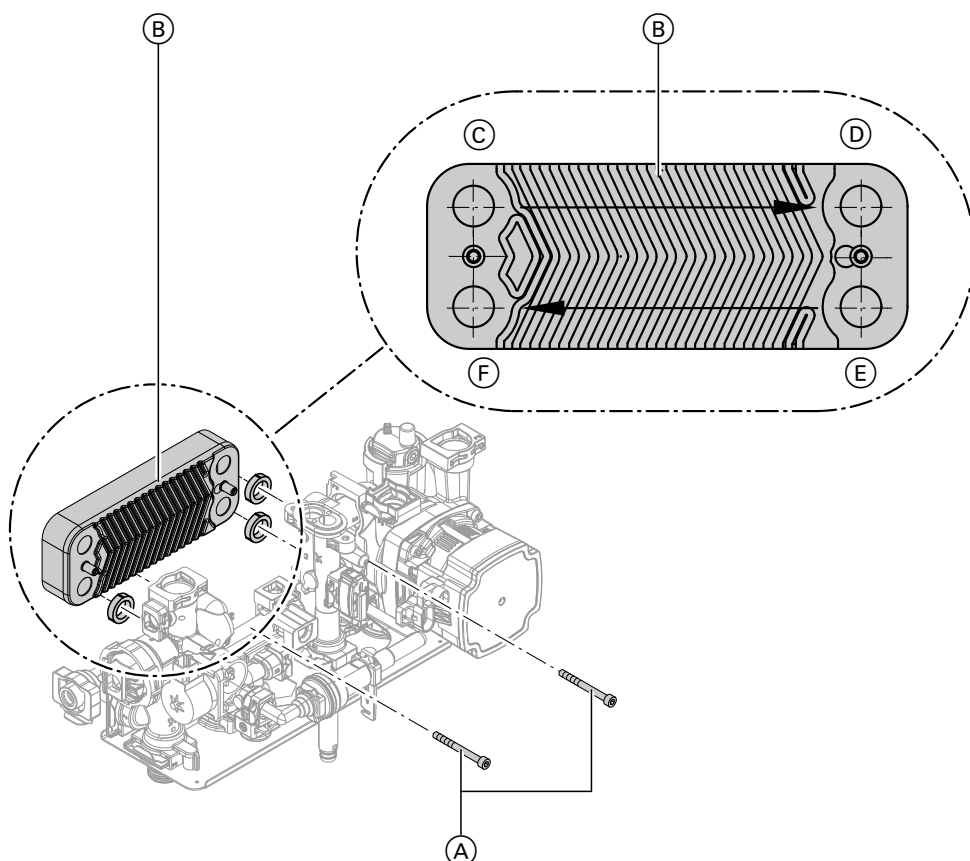

Fig. 50

- Ⓒ Heating water flow
- Ⓓ Heating water return

- Ⓔ Cold water
- Ⓕ DHW

1. Shut off and drain the boiler on the heating water and DHW sides.
2. Pivot the control unit downwards.
3. Undo 2 screws Ⓐ on plate heat exchanger Ⓑ and remove plate heat exchanger with gaskets.

Note

During and after removal, small amounts of water may trickle from the plate heat exchanger.

4. Check the connections on the DHW side for scaling; clean or replace the plate heat exchanger if required.

5. Check the connections on the heating water side for contamination; clean or replace the plate heat exchanger if required.
6. Install in reverse order using new gaskets.

Note

During installation, ensure the fixing holes are aligned and the gaskets are seated correctly. Fit the plate heat exchanger the right way round.

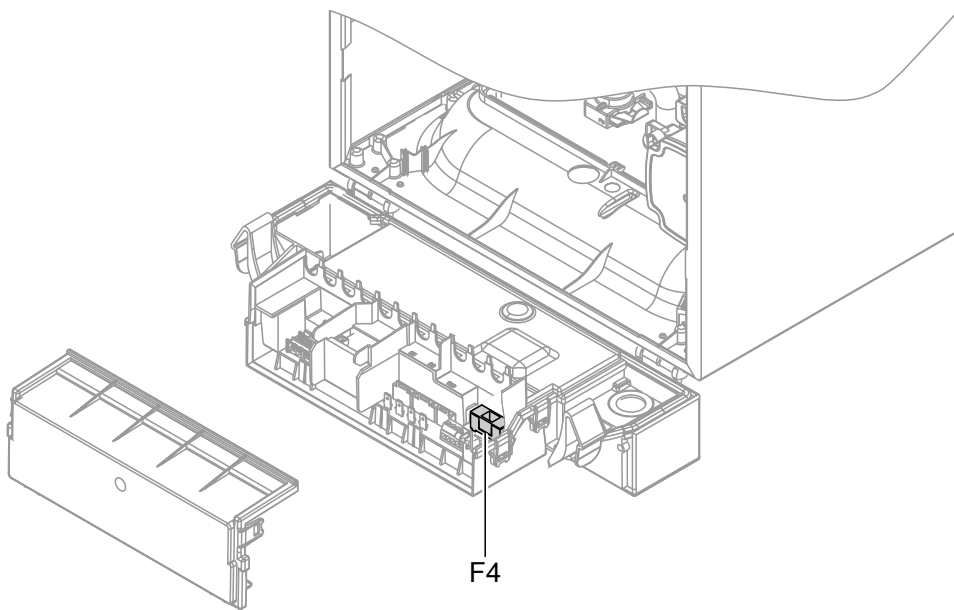
Repairs (cont.)**Checking the fuse***Fig. 51*

1. Switch OFF the power supply.
2. Open the control unit enclosure (see page 18).
3. Check fuse F4.

Functions and operating conditions in weather-compensated mode

In weather-compensated mode, the boiler water temperature is regulated subject to the outside temperature.

Heating curve for weather-compensated control

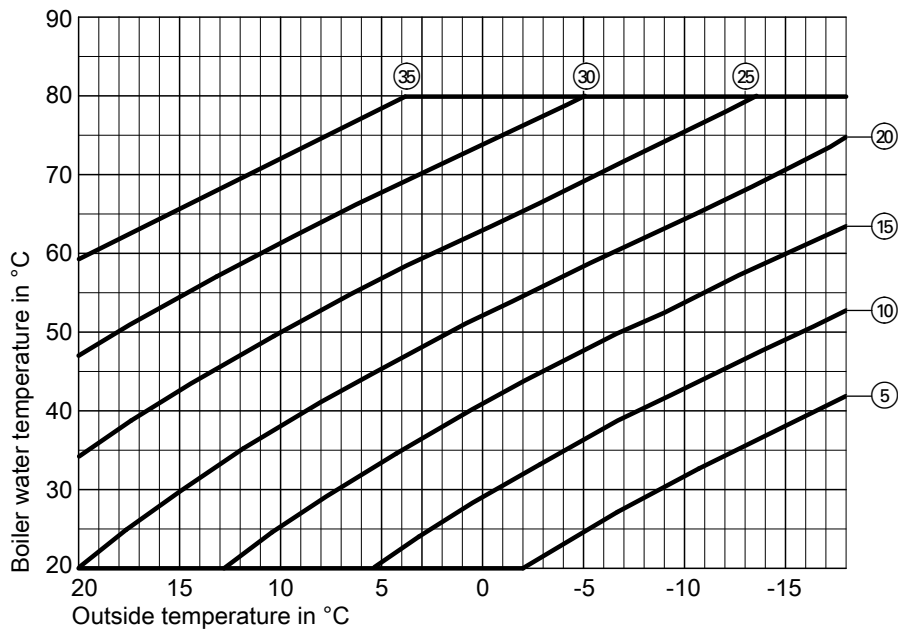



Fig. 52

- (X) Code for selected heating curve
The setting can be made in increments of - - to 35.

Set heating curve

1. Tap ▲/▼.
The set parameter flashes and  will be displayed.

2. Use ▲/▼ to select the parameter.

3. **OK** to confirm.

Frost protection function

The frost protection function requires an outside temperature sensor to be connected. Frost protection function is active at outside temperatures of $< 5\text{ }^{\circ}\text{C}$. The burner starts and the boiler water temperature is held at $20\text{ }^{\circ}\text{C}$.

Connection and wiring diagram

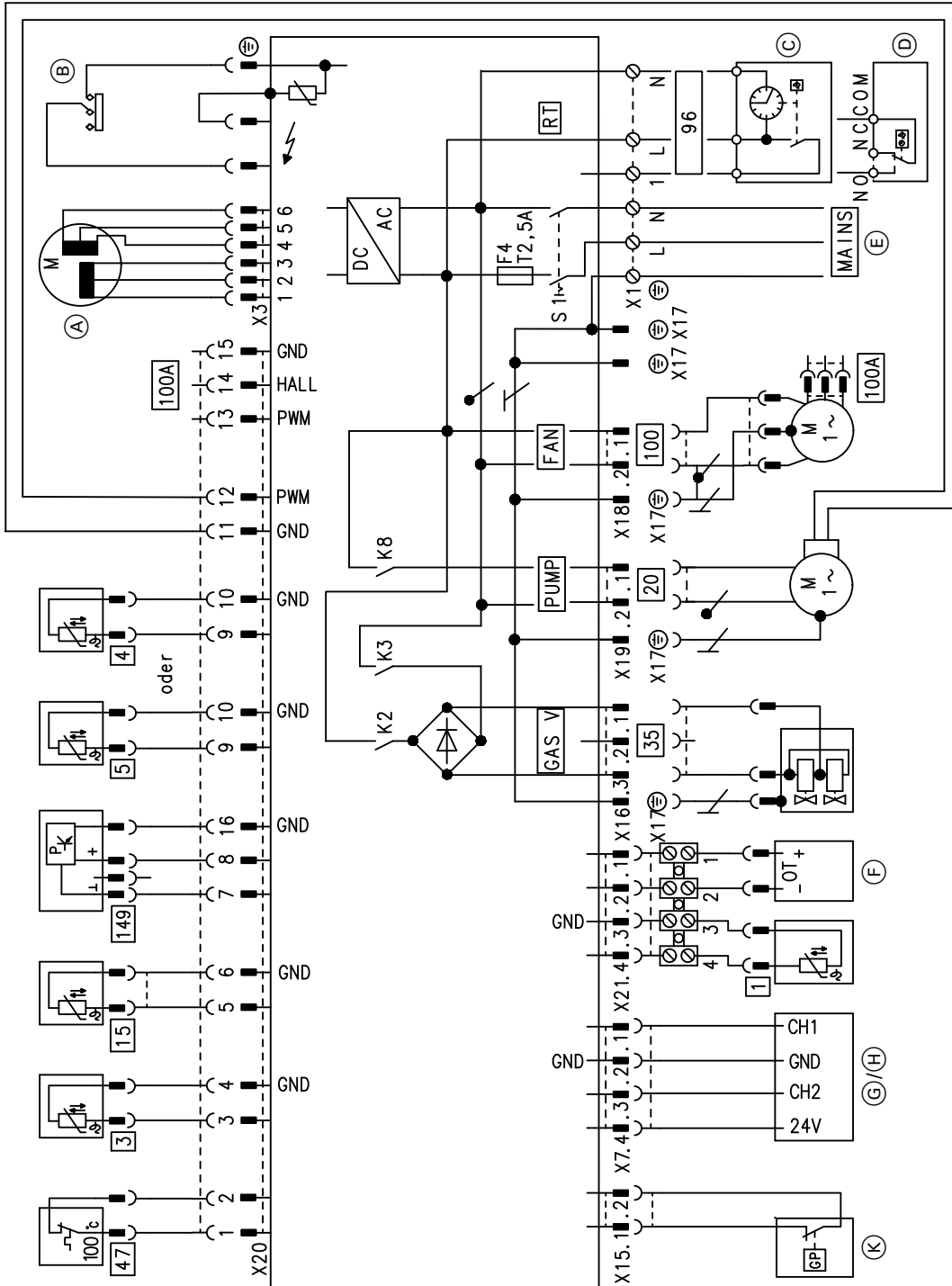

Fig. 53

- | | | | |
|-------|---|--------|--|
| (A) | Diverter valve stepper motor | [1] | Outside temperature sensor (accessories) |
| (B) | Ignition/ionisation | [3] | Boiler water temperature sensor |
| (C) | Vitotrol 100, type UTA or on-site room temperature controller (230 V switched input) | [4] | Outlet temperature sensor (gas condensing combi boiler) |
| (D) | Vitotrol 100, type UTDB or on-site room temperature controller (230 V switched input) | [5] | Cylinder temperature sensor (gas condensing system boiler) |
| (E) | Power supply 230 V/50 Hz | [15] | Flue gas temperature sensor |
| (F) | Remote control (OpenTherm device) or mixer extension kit (OpenTherm) | [20] | Circulation pump 230 V~ |
| (G) | Time switch (accessories) | [35] | Gas solenoid valve |
| (H) | Vitotrol 100, type UTDB-RF2 | [47] | Temperature limiter |
| (K) | Gas pressure switch (accessories) | [100] | Fan motor 230 V~ |
| X ... | Electrical interface | [100A] | Fan control |
| | | [149] | Flow sensor |

Reports

(cont.)

Settings and test values		Commis- sioning	Mainte- nance/ service	Mainte- nance/ service	Mainte- nance/ service	Mainte- nance/serv- ice
Date						
Signature						
Gas type	G					
Static pressure	<i>mbar</i> <i>kPa</i>					
Supply pressure (flow pres- sure)	<i>mbar</i> <i>kPa</i>					
Carbon dioxide content CO₂ ▪ Upper heating output ▪ Lower heating output	<i>% by vol.</i> <i>% by vol.</i>					
Oxygen content O₂ ▪ Upper heating output ▪ Lower heating output	<i>% by vol.</i> <i>% by vol.</i>					
Carbon monoxide content CO	<i>ppm</i>					

Specification

Gas condensing system boiler, class II_{2H3P}

Type		B1HC			
Rated heating output range in heating mode					
T_F/T_R 50/30 °C (Pcond(50/30))	kW	4.7 (6.5) ^{*1} – 19	4.7 (6.5) ^{*1} – 26	5.9 (8.8) ^{*1} – 30	5.9 (8.8) ^{*1} – 35
T_F/T_R 80/60 °C (Pn(80/60))	kW	4.3 (5.9) ^{*1} – 17.4	4.3 (5.9) ^{*1} – 23.8	5.4 (8.0) ^{*1} – 27.5	5.4 (8.0) ^{*1} – 32.1
Rated heating input range	kW	4.4 (6.1) ^{*1} – 17.8	4.4 (6.1) ^{*1} – 24.3	5.5 (8.2) ^{*1} – 28.0	5.5 (8.2) ^{*1} – 32.7
Connection values Relative to the max. load for:					
- Natural gas H	m ³ /h	1.88	2.6	2.96	3.46
- LPG P	kg/h	1.39	1.90	2.19	2.56
Rated voltage	V	230			
Rated frequency	Hz	50			
Rated current	A	2.0			
Backup fuse (max.)	A	16			
Power consumption (max.)	W	82	88	96	106
Permissible ambient temperature					
- during operation	°C	0 to +40			
- during storage and transport	°C	-20 to +65			
IP rating	IP X4 to EN 60529 (only for room sealed operation)				
Protection class	I				
Temperature limiter setting	°C	100 (fixed)			
Weight	kg	35	36	37	37
Product ID	CE-0063CQ3356				

Specification (cont.)

Gas condensing combi boiler, category II_{2H3P}

Type	B1KC			
Rated heating output range in heating mode				
T_F/T_R 50/30 °C (Pcond(50/30))	kW	4.7 (6.5)* ¹ – 26	5.9 (8.8)* ¹ – 30	5.9 (8.8)* ¹ – 35
T_F/T_R 80/60 °C (Pn(80/60))	kW	4.3 (5.9)* ¹ – 23.8	5.4 (8.0)* ¹ – 27.5	5.4 (8.0)* ¹ – 32.1
Rated heating output range for DHW heating	kW	4.3 (5.9)* ¹ – 26.0	5.4 (8.0)* ¹ – 30.0	5.4 (8.0)* ¹ – 35.0
Rated heating input range	kW	4.4 (6.1)* ¹ – 27.1	5.5 (8.2)* ¹ – 31.3	5.5 (8.2)* ¹ – 36.5
Connection values				
Relative to the max. load for:				
- Natural gas H	m ³ /h	2.87	3.31	3.86
- LPG P	kg/h	2.12	2.45	2.85
Rated voltage	V	230		
Rated frequency	Hz	50		
Rated current	A	2.0		
Backup fuse (max.)	A	16		
Power consumption (max.)	W	94	104	120
Permissible ambient temperature				
- during operation	°C	0 to +40		
- during storage and transport	°C	-20 to +65		
IP rating	IP X4 to EN 60529 (only for room sealed operation)			
Protection class	I			
Temperature limiter setting	°C	100 (fixed)		
DHW heating				
Permiss. operating pressure	bar	10	10	10
	MPa	1.0	1.0	1.0
Nominal water flow rate at ΔT 30 K (to EN 13203)	l/min	12.4	14.3	16.7
Set flow rate (max.)	l/min	10	12	14
Weight	kg	36	38	38
Product ID	CE-0063CQ3356			

Note

The supply values are only for reference (e.g. in the gas contract application) or for a supplementary, rough estimate to check the volumetric settings. Due to factory settings, the gas pressure must not be altered from these values. Reference: 15 °C, 1013 mbar (101.3 kPa).

*1 Only when operating with LPG P

Final decommissioning and disposal

Viessmann products can be recycled. Components and substances from the system are not part of ordinary household waste.

For decommissioning the system, isolate the system from the power supply and allow components to cool down where appropriate.
All components must be disposed of correctly.

Declaration of Conformity

We, Viessmann Werke GmbH & Co. KG, D-35107 Allendorf, declare as sole responsible body that the named product complies with the European directives and supplementary national requirements in terms of its design and operational characteristics.

Using the serial number, the full Declaration of Conformity can be found on the following website:

www.viessmann.co.uk/eu-conformity

Keyword index

- B**
 Boiler water temperature sensor 55
 Burner gasket.....40
 Burner gauze assembly..... 40
 Burner installation..... 43
 Burner removal.....40
- C**
 Certificates..... 68
 CO2 content check.....39
 Combustion chamber cleaning.....42
 Commissioning.....24
 Condensate..... 16
 Condensate drain..... 16, 43
 Connection diagram..... 63
 Connections..... 11, 14
 Connections on the water side..... 14
 Control unit, closing.....22
 Control unit, opening..... 18
 Cylinder temperature sensor 56
- D**
 Diaphragm expansion vessel..... 44
 Dimensions..... 11
- E**
 Electrical connections..... 19
- F**
 Fault..... 50
 Fault code..... 50
 Fault display..... 50
 Filling function..... 24
 Fill water..... 24
 Flow limiter..... 59
 Flue gas cascade..... 36
 Flue gas temperature sensor..... 58
 Flue pipe..... 17
 Front panel, mounting..... 45
 Front panel removal..... 14, 18
 Frost limit..... 62
 Frost protection..... 62
 Function sequence..... 50
 Fuse..... 61
- G**
 Gas connection..... 16
 Gas supply pressure..... 27
 Gas train 27
 Gas type, changing
 – LPG..... 26, 48
 Gas type conversion
 – At control unit..... 48
 Gas type selected..... 26
- H**
 Heat exchanger cleaning..... 42
 Heating curve..... 62
- I**
 Ignition.....41
 Ignition electrode.....41
 Intended use..... 8
 Ionisation electrode..... 41
- L**
 Limits
 – Flue gas values..... 26
 LPG..... 26
- M**
 Max. heating output.....28
- O**
 Outlet temperature sensor..... 57
 Output adjustment
 – Shared connection..... 30
 Output matching
 – Flue gas cascade..... 36
 – Flue pipe length.....29
 Output reduction.....28
 Outside temperature sensor.....21, 54
- P**
 Plate heat exchanger..... 60
 Power supply.....22
 Preparing for installation..... 11
 Pressure in the system.....44
 Product information..... 9
 Pump rate adjustment..... 29
- R**
 Report..... 64
 Reset..... 52
- S**
 Safety chain 56
 Safety valve..... 16
 Shared flue system connection..... 30
 Static pressure..... 27
 Supply pressure..... 27
 Symbols..... 8
 System, filling..... 24, 25
 System pressure..... 25, 44
- T**
 Temperature limiter..... 56
 Trap..... 17, 43
 Troubleshooting.....53
- V**
 Ventilation air pipe..... 17
 Venting..... 25
 Vitotrol 100
 – Connection.....21
- W**
 Wall mounting.....12
 Wall mounting bracket..... 12

Keyword index

Keyword index (cont.)

Water quality.....	24
Weather-compensated mode.....	62



Viessmann Werke GmbH & Co. KG
D-35107 Allendorf
Telephone: +49 6452 70-0
Fax: +49 6452 70-2780
www.viessmann.com



Viessmann Limited
Hortonwood 30, Telford
Shropshire, TF1 7YP, GB
Telephone: +44 1952 675000
Fax: +44 1952 675040
E-mail: info-uk@viessmann.com

5697787 Subject to technical modifications.