

Installation Instructions

for use by heating contractor



Step Motor

Part number: 7828748 **Step Motor**

for use with: Vitodens 100-W B1HA and B1KA

Safety and Installation Requirements

Please ensure that these instructions are read and understood before starting any service work. Failure to comply with these instructions may cause product/property damage, severe personal injury and/or loss of life.

Working on the equipment

The installation, adjustment, service and maintenance of this product must be performed by a licensed professional heating contractor who is qualified and experienced in the installation, service, and maintenance of hot water boilers. There are no user serviceable parts on the boiler, burner or control.

Ensure that main power to the equipment being serviced is off.

Ensure that the main fuel supply valve to the boiler is closed.

Take precautions to avoid accidental activation of power or fuel during service work.

Do not perform service work on any component part without ensuring safe operation of the heating system. When replacing parts, use original Viessmann or Viessmann approved replacement parts.



Refer to the Installation and Service Instructions applicable to this boiler.

Removing the Front Panel

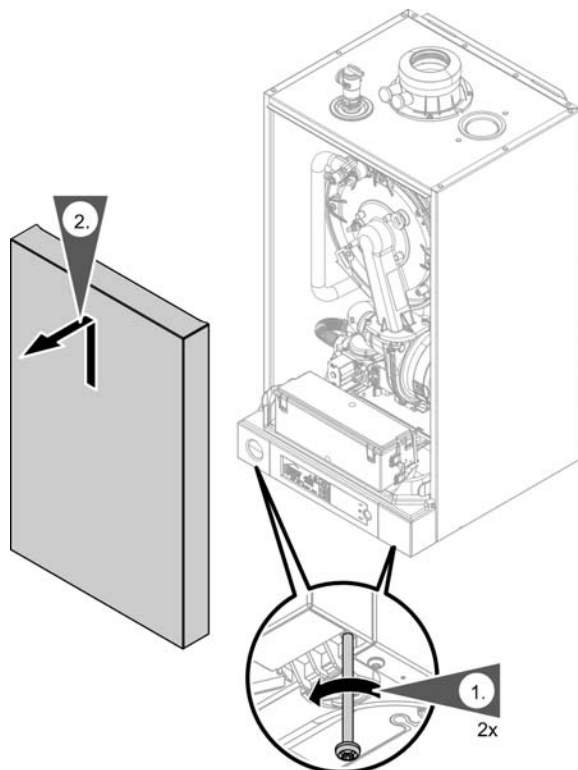

1. Loosen retaining screws (do not remove completely).
2. Remove front panel.

Replacing the Step Motor

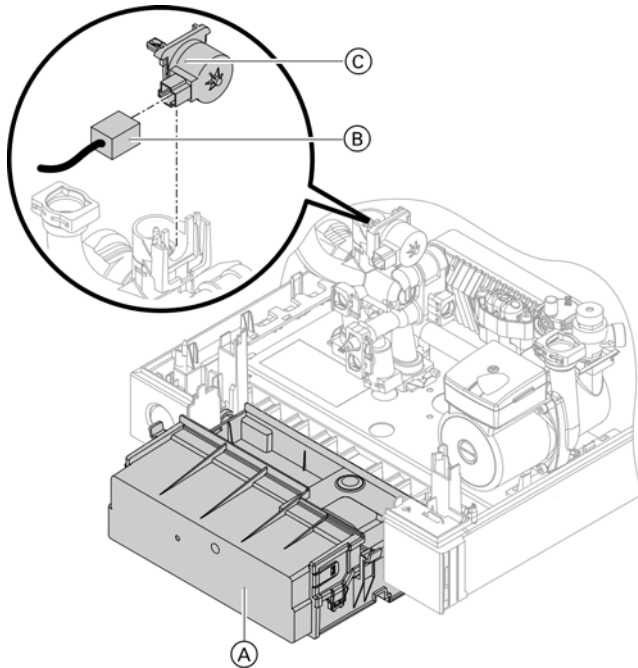

1. Press the retaining tabs and fold down the control (A).
2. Remove cable (B) from step motor (C).
3. Remove step motor (C) by pulling straight up.
4. Install new step motor (C) and connect cable (B).
5. Return the control (A) into position.

Printed on environmentally friendly
(recycled and recyclable) paper.



Reinstalling the Front Panel

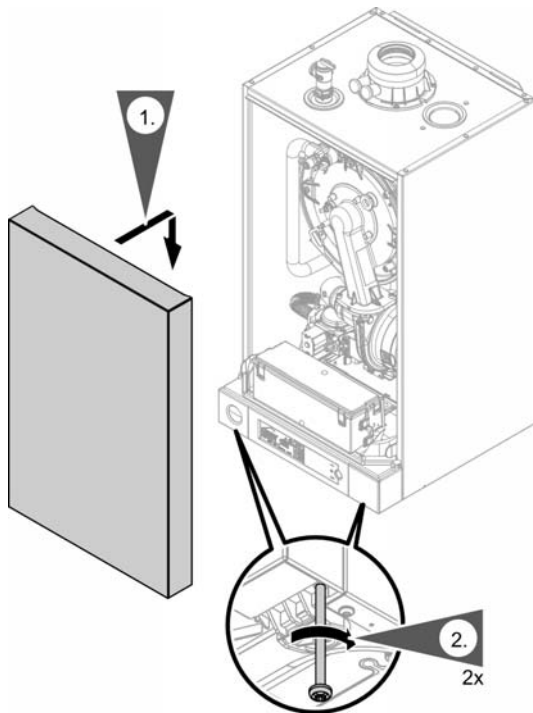

1. Install the front panel.
2. Tighten the screws at the bottom of the boiler.

Technical information subject to change without notice.