

Installation and service instructions

for contractors

VIESSMANN

Vitodens 242-F

Type **FB2B**, 4.8 to 26 kW

Gas condensing/solar storage combi boiler

Natural gas and LPG version

Gas Council no.:

47-819-18 (19 kW)

47-819-19 (26 kW)

For applicability, see the last page

VITODENS 242-F



Safety instructions



Please follow these safety instructions closely to prevent accidents and material losses.

Safety instructions explained



Danger

This symbol warns against the risk of injury.



Please note

This symbol warns against the risk of material losses and environmental pollution.

Note

Details identified by the word "Note" contain additional information.

Target group

These instructions are exclusively designed for qualified personnel.

- Work on gas equipment must only be carried out by a qualified gas fitter.
- Work on electrical equipment must only be carried out by a qualified electrician.
- The system must be commissioned by the system installer or a qualified person authorised by the installer.

Regulations

Observe the following when working on this system

- all legal instructions regarding the prevention of accidents,
- all legal instructions regarding environmental protection,
- the Code of Practice of relevant trade associations,

- all current safety regulations as defined by DIN, EN, DVGW, TRGI, TRF, VDE and all locally applicable standards,
- Gas Safety (Installation & Use) Regulations
 - the appropriate Building Regulation either the Building regulations, the Building Regulation (Scotland), Building Regulations (Northern Ireland),
 - the Water Fittings Regulation or Water Bylaws in Scotland,
 - the current I.E.E. Wiring Regulations.

If you smell gas



Danger

Escaping gas can lead to explosions which may result in serious injury.

- Never smoke. Prevent naked flames and sparks. Never switch lights or electrical appliances ON or OFF.
- Close the gas shut-off valve.
- Open windows and doors.
- Remove all people from the danger zone.
- Notify your gas or electricity supplier from outside the building.
- Shut off the electricity supply to the building from a safe place (outside the building).

Safety instructions (cont.)

If you smell flue gas



Danger

Flue gas can lead to life-threatening poisoning.

- Shut down the heating system.
- Ventilate the boiler room.
- Close all doors leading to the living space.

Working on the system

- When using gas as fuel, also close the main gas shut-off valve and safeguard against unauthorised reopening.
- Isolate the system from the power supply and check that it is no longer 'live', e.g. by removing a separate fuse or by means of a main isolator.
- Safeguard the system against unauthorised reconnection.



Please note

Electronic modules can be damaged by electro-static discharges.

Touch earthed objects, such as heating or water pipes, to discharge static loads.

Repair work



Please note

Repairing components which fulfil a safety function can compromise the safe operation of your heating system.

Replace faulty components only with original Viessmann spare parts.

Ancillary components, spare and wearing parts



Please note

Spare and wearing parts which have not been tested together with the heating system can compromise its function. Installing non-authorised components and non-approved modifications/conversion can compromise safety and may invalidate our warranty. For replacements, use only original spare parts from Viessmann or those which are approved by Viessmann.

Index

Installation instructions

Preparing for installation

Product information.....	6
Preparing for installation.....	6

Installation sequence

Installing the boiler.....	11
Opening the control unit casing.....	15
Electrical connections.....	16
Closing the control unit casing.....	22

Service instructions

Commissioning, inspection, maintenance

Steps - commissioning, inspection and maintenance.....	24
Further details regarding the individual steps.....	26

Code 1

Calling up coding level 1.....	66
General.....	67
Select boiler	69
DHW.....	70
Solar.....	70
Heating circuit 1, heating circuit 2, heating circuit 3.....	71

Code 2

Calling up coding level 2.....	76
General.....	76
Select boiler.....	84
DHW.....	86
Solar.....	88
Heating circuit 1, heating circuit 2, heating circuit 3.....	91

Diagnosis and service scans

Calling up the service menu.....	98
Diagnosis.....	98
Checking outputs (actuator test).....	101

Troubleshooting

Fault display.....	103
Fault codes.....	104
Repairs.....	114

Index (cont.)**Function description**

Control unit.....	127
Internal extensions.....	129
External extensions (accessories).....	131
Control functions.....	135
Allocating heating circuits to the remote control.....	143
Electronic combustion controller.....	143

Designs

Internal connection diagram.....	145
External connection diagram.....	146
Connection diagram, solar control module.....	148

Parts lists	149
--------------------------	-----

Commissioning/service reports	159
--	-----

Specification	160
----------------------------	-----

Certificates

Declaration of conformity.....	161
Manufacturer's certificate according to the 1st BImSchV [Germany].....	162

Keyword index	163
----------------------------	-----

Preparing for installation

Product information

Vitodens 242-F, FB2B

Set up for operation with natural gas H.

For conversion to LPG P (without conversion kit), see page 32.

The Vitodens 242-F should generally only be delivered to those countries specified on the type plate. For deliveries to alternative countries, an approved contractor, on his own initiative, must arrange individual approval in accordance with the law of the land.

Preparing for installation

Handling

If possible, leave the boiler on the pallet during handling.

If space constraints make it necessary, the boiler can be split for handling.



Please note

To prevent equipment damage, never set the boiler down on its front or side panels or apply loads to these areas.



Installation instructions provided

Installation

Required room height at least 2100 mm.

The boiler weight is 161 kg (19 kW) to 165 kg (26 kW) (dry).

Preparing the boiler for installation

Use a connection set, available as an accessory, to make the connection on the gas and water sides. The following overview shows sample connection sets for installation on finished walls to the top or side.

Preparing the connections on site:



Connection set installation instructions.



Please note

To prevent equipment damage, install all pipework free of load and torque stresses.

Preparing for installation (cont.)

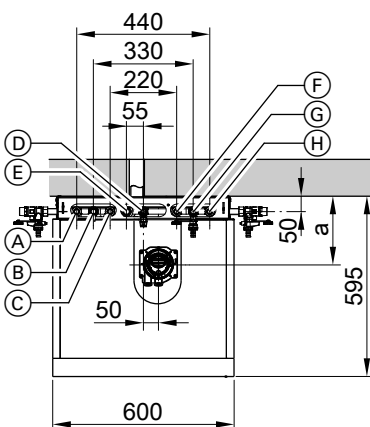
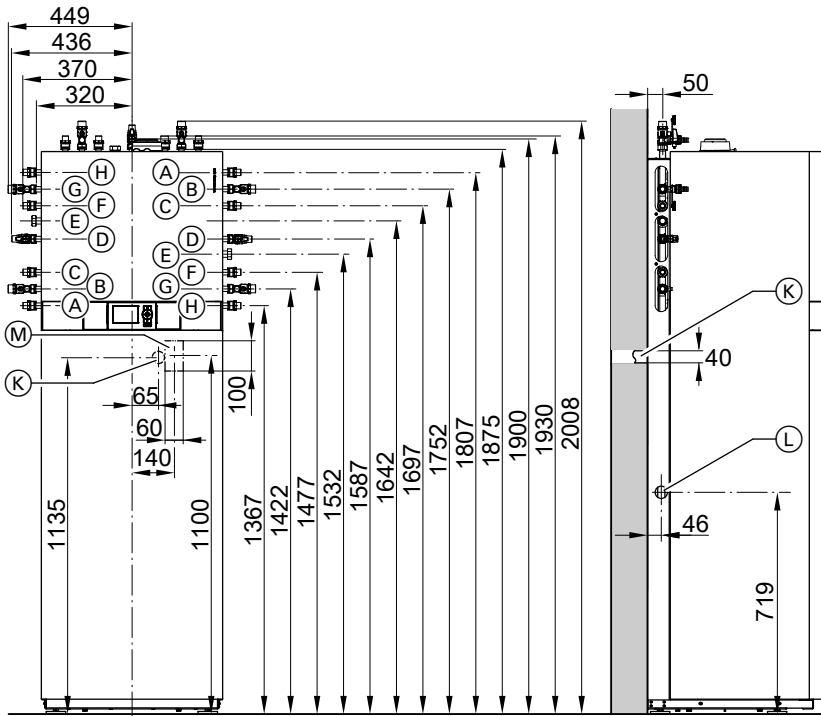

- (A) Solar return R $\frac{3}{4}$
- (B) Heating flow R $\frac{3}{4}$
- (C) DHW R $\frac{1}{2}$
- (D) Gas connection R $\frac{1}{2}$
- (E) DHW circulation R $\frac{1}{2}$ (separate accessory)
- (F) Cold water R $\frac{1}{2}$
- (G) Heating return R $\frac{3}{4}$
- (H) Solar flow R $\frac{3}{4}$
- (K) Condensate drain to the back into the wall
- (L) Side condensate drain
- (M) Cable entry area
- (N) DHW safety valve drain

Preparing for installation

Preparing for installation (cont.)

Minimum clearances

Area around the Vitodens for maintenance: min. 700 mm.

Maintenance clearances to the l.h. or r.h. side of the Vitodens are **not** required.

Rated output range	4.8 to 19 kW	6.5 to 26 kW
a (mm)	200	224

Note

The adjustable feet give all height measurements a tolerance of +15 mm.

1. Prepare the heating water connections.
Flush the heating system thoroughly.

Note

Should an additional diaphragm expansion vessel be required on site, connect that vessel into the heating return.

Preparing for installation (cont.)

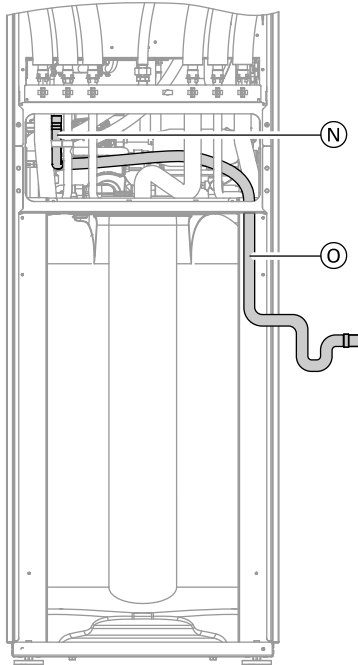

2. Prepare the connections on the DHW side. Install the safety assembly (accessory or on-site provision) in accordance with the Water Fittings Regulations 1999 in the cold water line (see page 10).
Recommendation:
Install the safety valve above the DHW cylinder to protect it against contamination, scaling and high temperatures.
Connect the drain hose to the condensate collector. Remove plug from condensate collector.
3. Prepare the solar connections.
4. Route condensate hose (O) to the back (drain in wall (K)) or to the side aperture (L) (see page 6).
Route condensate hose with a U-bend and connect to on-site drain line or siphon. Discharge pipes from expansion valves (safety valve) should not be connected directly to a drain and should pass through a visible tundish, with a AUK3 air gap, and be located adjacent to the device.
5. Prepare the gas connection according to TRGI or TRF or all local regulations.
6. Prepare the electrical connections.
 - Power cable: NYM-J 3 x 1.5 mm², fuse max. 16 A, 230 V/50 Hz.
 - Accessory cables: NYM with the required number of conductors for the external connections.
 - Allow all cables in area "(M)" (see page 7) to protrude 2000 mm from the wall.

Preparing for installation (cont.)

Safety assembly to Water Fittings Regulations 1999

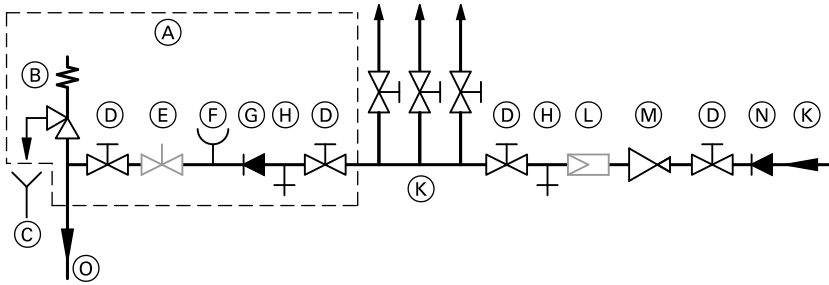

- | | |
|--|---|
| (A) Safety assembly to Water Fittings Regulations 1999 (accessory to connection sets for unfinished walls) | (G) Non-return valve |
| (B) Safety valve | (H) Drain |
| (C) Visible blow-off line outlet | (K) Cold water |
| (D) Shut-off valve | (L) Drinking water filter |
| (E) Flow regulating valve (installation recommended) | (M) Pressure reducer to Water Fittings Regulations 1999 |
| (F) Pressure gauge connector | (N) Non-return valve/pipe separator |
| | (O) Cold water connection at connection set (accessory) |

Installing the boiler

Assembling the boiler

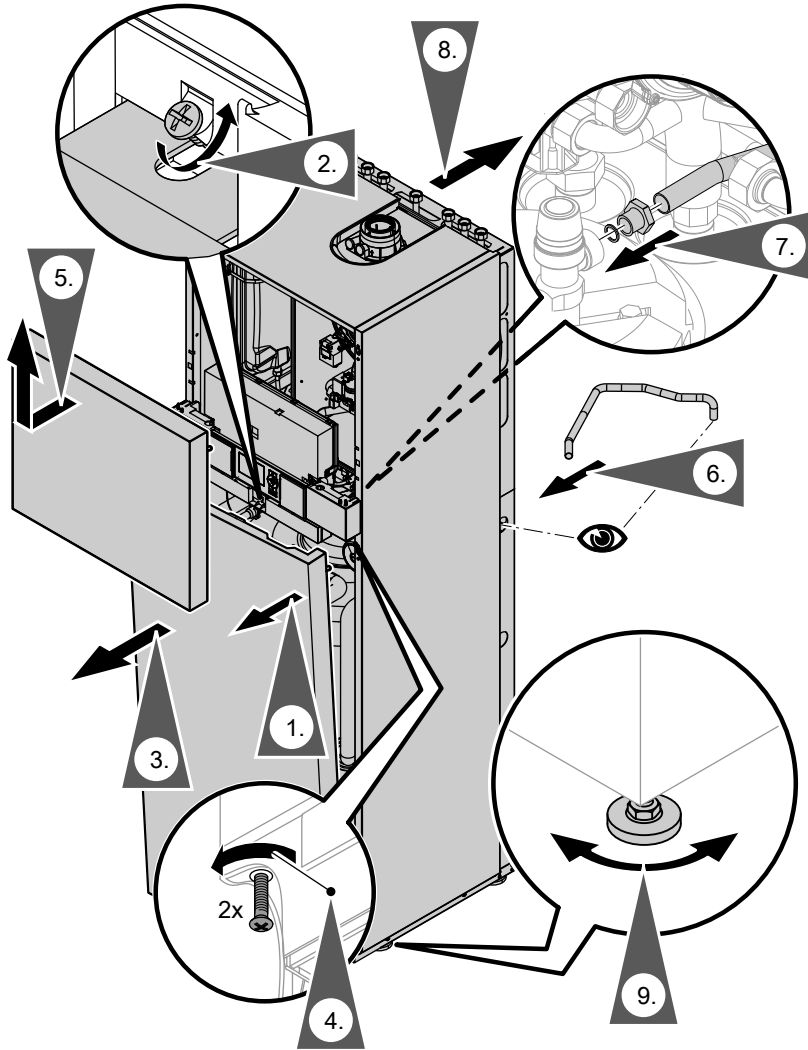

Installing the boiler (cont.)

Connections on the heating water and the DHW side

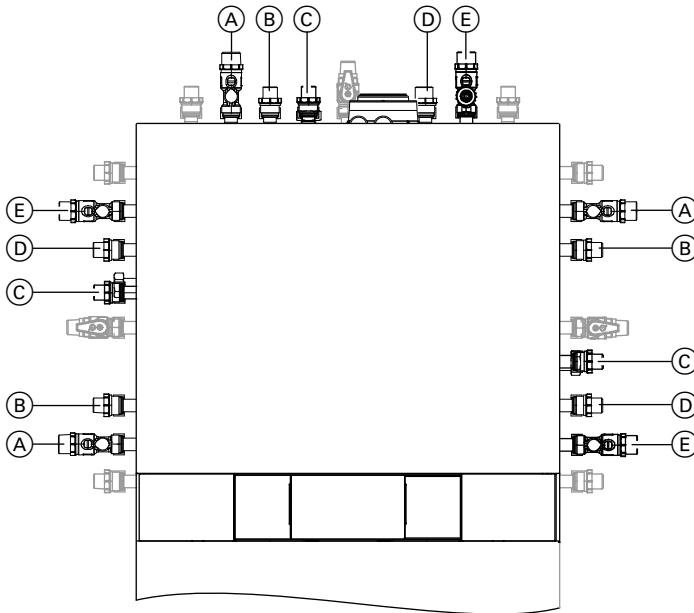

Shown with connection sets for finished walls (accessories)

- Ⓐ Heating flow R $\frac{3}{4}$
- Ⓑ DHW R $\frac{1}{2}$
- Ⓒ DHW circulation R $\frac{1}{2}$ (separate accessory)
- Ⓓ Cold water R $\frac{1}{2}$
- Ⓔ Heating return R $\frac{3}{4}$

Fitting the drain outlet and drain line to the T&P valve



Separate installation instructions

DHW circulation connection

DHW circulation connection with DHW circulation pump connection set (accessory)



Separate installation instructions

Installing the boiler (cont.)

Connections on the solar side

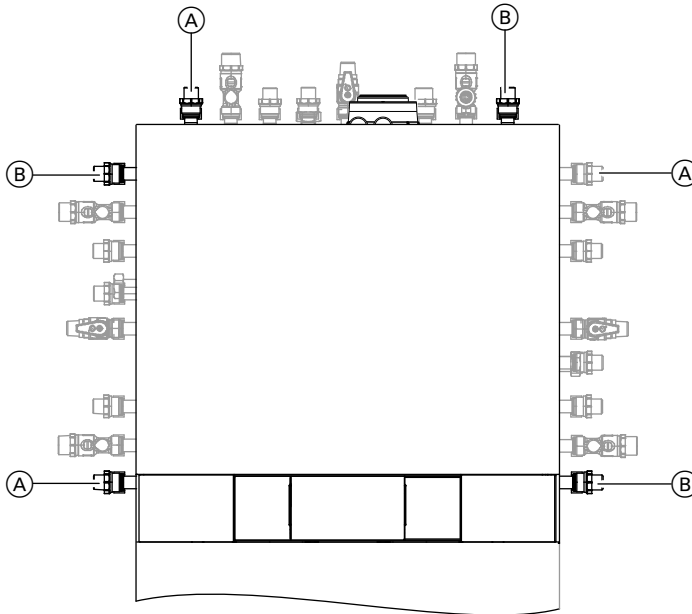

Shown with connection sets for finished walls (accessories)

(A) Solar return R $\frac{3}{4}$ or $\text{\O}22$ mm smooth tube

(B) Solar flow R $\frac{3}{4}$ or $\text{\O}22$ mm smooth tube

Note

The solar circuit pump is integrated into the boiler.

The solar safety valve can be fitted in the boiler. Set the pressure gauge for the solar circuit on site.

The expansion vessel, available as an accessory, is installed in the solar return.

Note

Route the blow-off pipe for the safety valve on the solar side into a suitable and adequately sized drip container. A drip container (2.5 litres) to be fitted in the boiler is available as an accessory.



Separate installation instructions

Installing the boiler (cont.)

Gas connection

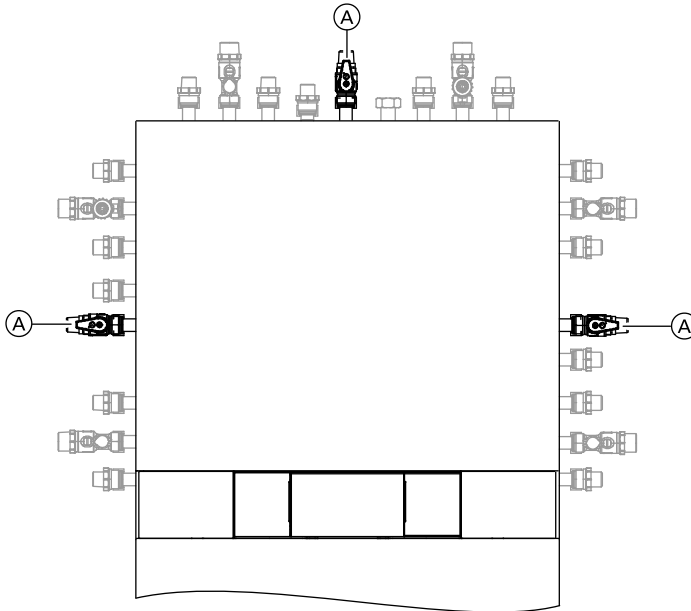

Shown with connection sets for finished walls (accessories)

Ⓐ Gas connection R ½

Notes regarding operation with LPG.

We recommend the installation of an external safety solenoid valve when installing the boiler in rooms below ground level.

1. Fix gas shut-off valve to gas connection Ⓐ.

2. Carry out a tightness test.

Note

For the tightness test, use only suitable and approved leak detecting agents (EN 14291) and devices. Leak detecting agents with unsuitable contents (e.g. nitrides, sulphides) can lead to material damage. Remove residues of the leak detecting agent after testing.

Installing the boiler (cont.)

! **Please note**
 Excessive test pressure may damage the boiler and the gas valve.
 Max. test pressure 150 mbar.
 Where higher pressure is required for tightness tests, separate the boiler and the gas valves from the gas supply pipe (undo the fitting).

3. Vent the gas line.

For conversion to a different gas type see page 32

Flue gas connection

Connect the balanced flue. The flue terminals have to be installed as described in accordance with the Building Regulations Part J and BS 5440.



Flue gas system installation instructions.

Opening the control unit casing

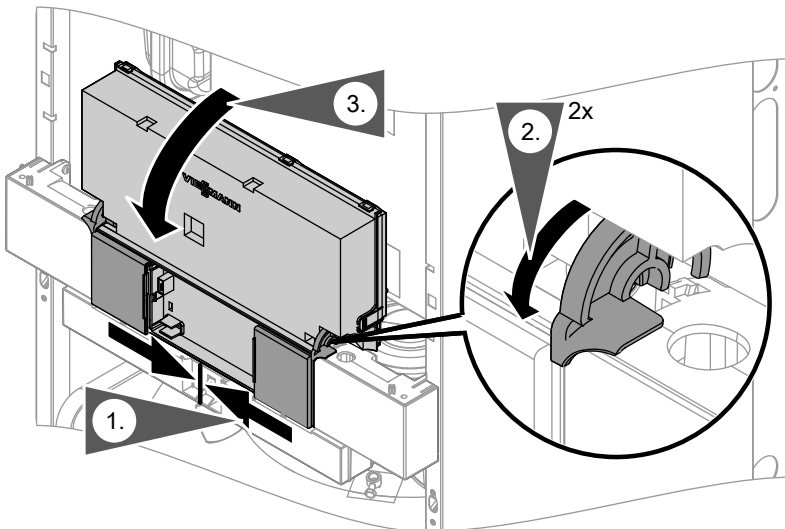

Opening the control unit casing (cont.)

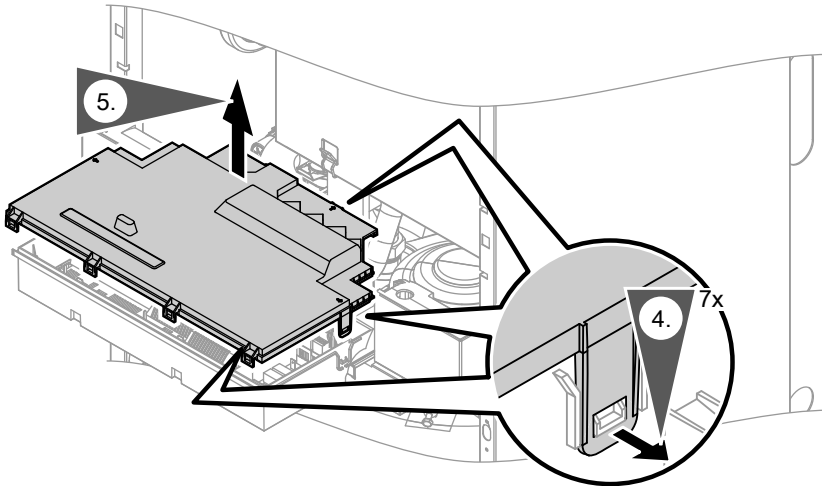

Electrical connections



Information regarding the connection of accessories

For the connection, observe the separate installation instructions provided with the accessory components.



Please note

Electronic modules can be damaged by electrostatic discharges. Before beginning work, touch earthed objects, such as heating or water pipes, to discharge static loads.

Electrical connections (cont.)

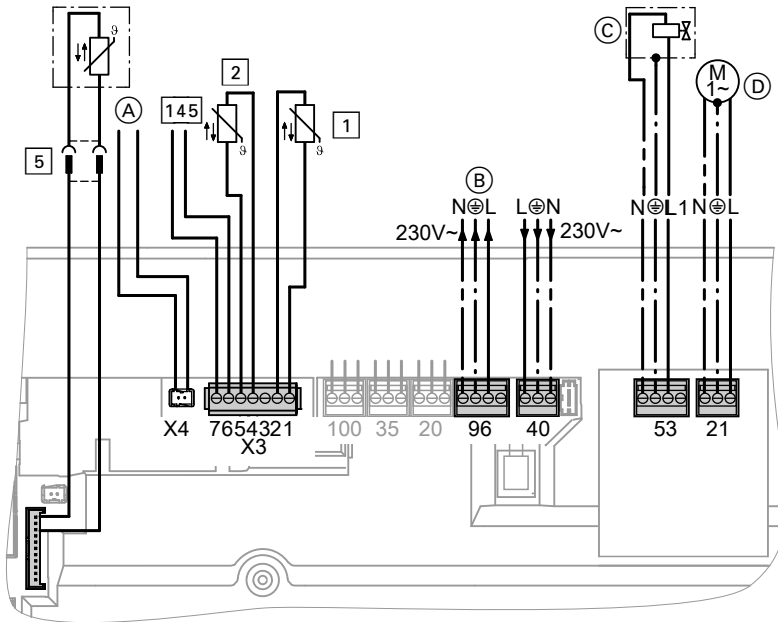

Installation

- (A) Solar control module KM BUS connection (connected in the delivered condition)
- (B) Power supply, solar control module (connected in the delivered condition)

- (C) External safety solenoid valve (LPG)
- (D) Cylinder primary pump

Plug 230 V~

- [21] Cylinder primary pump (D) (fitted and connected)

- [40] Power supply
 - Remove any existing individual cores.



Danger

Incorrect core termination can cause severe injuries and damage to the equipment.



Electrical connections (cont.)

Never interchange cores "L1" and "N".

- Install an isolator in the power supply line that simultaneously isolates all non-earthed conductors from the mains with at least 3 mm contact separation. We additionally recommend installing an AC/DC-sensitive RCD (RCD class B ) for DC (fault) currents that can occur with energy efficient equipment. Remove the existing cable grommet when using larger cross-sections (up to $\varnothing 14$ mm). Secure the cable with cable grommet (F) (see page 21) integrated into the casing base.
- Max. fuse rating 16 A.
- 53** External safety solenoid valve (LPG) (C)
Do **not** remove jumper between "1" and "L" when making this connection.
- 96** Power supply of accessories
Where the boiler is installed in a wet area, the connection of accessories to the power supply must not be carried out at the control unit. If the boiler is installed outside wet areas, the power supply for accessories can be connected directly to the control unit (230 V/50 Hz). The connection is switched by the system ON/OFF switch.

Note

If the total system current exceeds 6 A, connect one or more extensions via a mains isolator directly to the mains supply; see page 19.

Low voltage plug X3

- 1** Outside temperature sensor

Installation:

- North or north-western wall, 2 to 2.5 m above ground level; in multi-storey buildings, in the upper half of the second floor
 - Not above windows, doors or ventilation outlets
 - Not immediately below balconies or gutters
 - Never render over
 - Cable length max. 35 m with a cross-section of 1.5 mm²
- 2** Flow temperature sensor for low loss header (accessories)
- 5** Cylinder temperature sensor (fitted and connected)
- 145** KM BUS subscriber (accessory)
- Vitotrol 200A or 300A remote control
 - Vitocom 100
 - Extension kit for one heating circuit with mixer
 - Extension AM1 or EA1
 - Open Therm extension

Electrical connections (cont.)

Connection of accessories

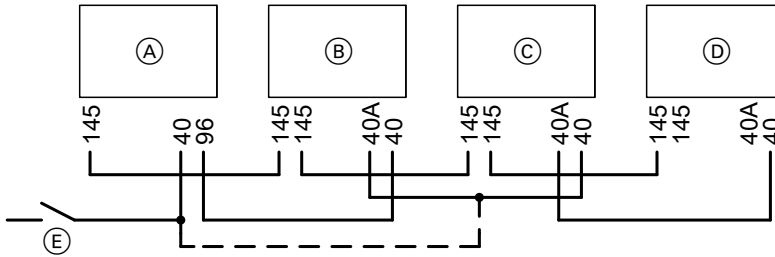

- (A) Boiler control unit
- (B) Extension kit for a heating circuit with mixer M2
- (C) Extension kit for heating circuit with mixer M3
- (D) Extension AM1, EA1 and/or solar control module SM1
- (E) ON/OFF switch

If a current flows to the actuators connected (e.g. circulation pumps) that is higher than the safety level of the accessory, only use the output concerned to control an on-site relay.

Accessories	Internal fuse protection
Extension kit for one heating circuit with mixer	2 A
Extension AM1	4 A
Extension EA1	2 A
Solar control module SM1	2 A

Connecting the collector temperature sensor

Note

Solar control module (A) is attached to the l.h. side of the air box.

Installation

Installation sequence

Electrical connections (cont.)

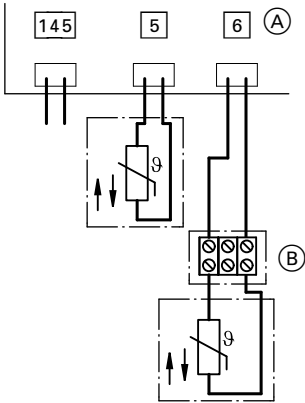

Connect collector temperature sensor [6] to terminal box (B) of solar control module (A).

On-site extension cable: 2-core, cross-section 1.5 mm².

Note

The cylinder temperature sensor for solar heating [5] is delivered fitted and connected.

Electrical connections (cont.)

Routing the connecting cables



Please note

Connecting cables will be damaged if they touch hot parts. When routing and securing power cables on site, ensure that the maximum permissible temperatures for these cables are not exceeded.

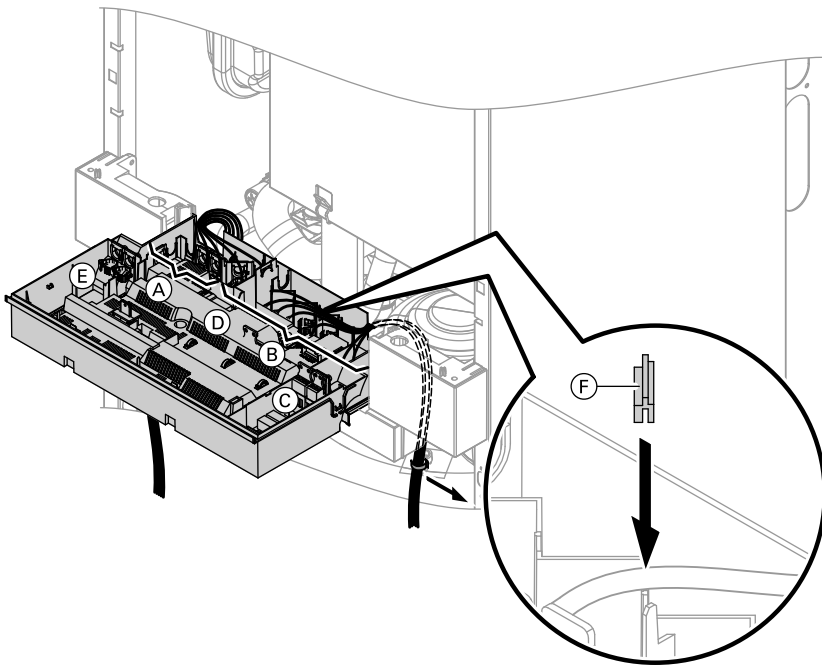

- (A) Low voltage connections
- (B) 230 V connections
- (C) Internal extension
- (D) Main PCB

- (E) Communication module (accessories)
- (F) Cable grommet for power cable

Remove the existing cable grommet when using larger cross-sections (up to \varnothing 14 mm). Secure the cable with cable grommet (F) (black) integrated into the casing base.

Installation sequence

Closing the control unit casing

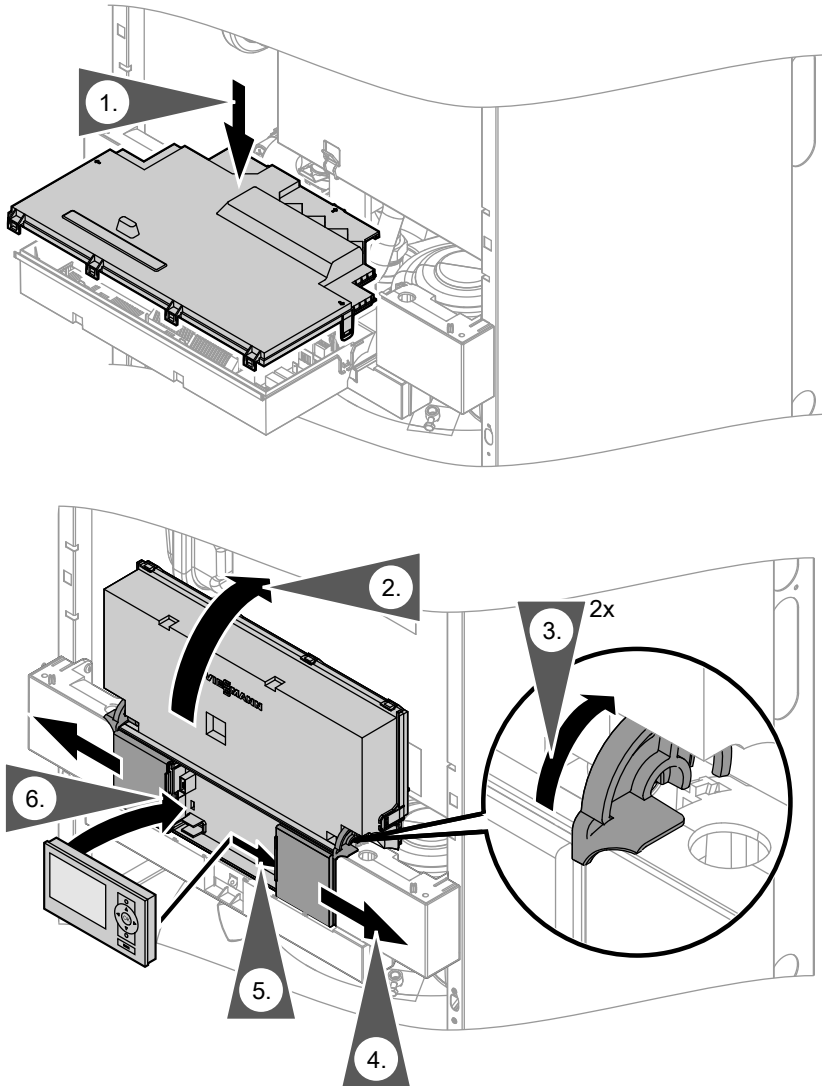

Insert programming unit (packed separately) into the control unit support.

Note

The programming unit can also be used in a wall mounting base (accessory) near the boiler.

Closing the control unit casing (cont.)



Wall mounting base installation
instructions

Steps - commissioning, inspection and maintenance

For further information regarding the individual steps, see the page indicated

				Page
			Commissioning steps	
			Inspection steps	
			Maintenance steps	
			1. Removing the front panels	26
			2. Filling the heating system	26
			3. Checking the power supply connection	
			4. Changing the language (if required)	27
			5. Setting the time and date (if required)	28
			6. Venting the boiler	28
			7. Venting the heating system	28
			8. Filling siphon with water	29
			9. Filling the solar circuit	30
			10. Checking all connections on the heating water side and DHW side for leaks	
			11. Naming the heating circuits	31
			12. Checking the gas type	31
			13. Gas type conversion (only for operation with LPG)	32
			14. Function sequence and possible faults	32
			15. Checking the static and supply pressure	34
			16. Setting the maximum output	36
			17. Checking the balanced flue system tightness (annular gap check)	37
			18. Removing the burner	38
			19. Checking the burner gasket and burner gauze assembly	39
			20. Checking and adjusting the ignition and ionisation electrodes	40
			21. Cleaning the heat exchanger and fitting the burner	40
			22. Checking the condensate drain and cleaning the siphon	42

Steps - commissioning, inspection and... (cont.)

			Page
		Commissioning steps	
		Inspection steps	
		Maintenance steps	
		• 23. Checking the neutralising system (if installed)	
•		24. Checking the anode connection.....	43
	•	25. Testing the anode earth current with an anode tester	43
	•	26. Draining the boiler on the DHW side.....	45
	•	27. Cleaning the primary store.....	46
	•	28. Checking and replacing the magnesium anode (if required).....	47
	•	29. Returning the primary store into use.....	48
	•	30. Checking the diaphragm expansion vessel and system pressure.....	49
•	•	31. Checking the function of safety valves	
•	•	32. Checking electrical connections are firmly seated	
•	•	33. Checking gas equipment for tightness at operating pressure.....	49
•	•	34. Checking the combustion quality.....	50
•	•	35. Checking the external LPG safety valve (if installed)	
•		36. Matching the control unit to the heating system.....	51
•		37. Adjusting the heating curves.....	58
•		38. Connecting the control unit to the LON.....	61
	•	39. Scanning and resetting the "Service" display.....	63
•	•	40. Fitting the front panels.....	64
•		41. Instructing the system user.....	65

Service

Further details regarding the individual steps

Removing the front panels

See page 11, steps 1 to 5.

Filling the heating system



Please note

- Unsuitable fill water increases the level of deposits and corrosion and may lead to boiler damage.
 - Thoroughly flush the entire heating system prior to filling it with water.
 - Only use fill water of potable quality.
 - Soften fill water with hardness exceeding 300 ppm (3.0 mmol/l), e.g. with a small softening system for heating water (see Vitoset pricelist).
 - An antifreeze additive suitable for heating systems can be added to the fill water.

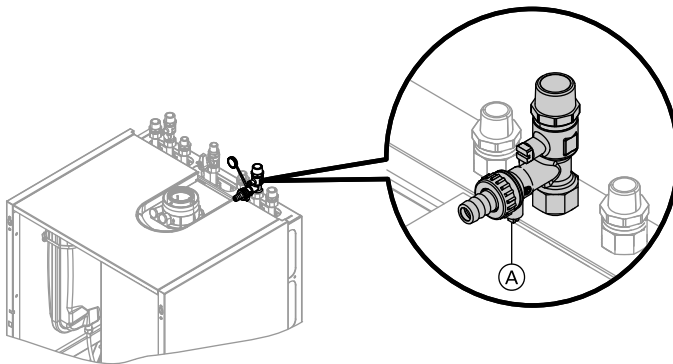

Shown with connection set for finished walls (accessory)

1. Check the pre-charge pressure of the diaphragm expansion vessel.
2. Close the gas shut-off valve.
3. Fill heating system via boiler drain & fill valve **A** in the heating return (depending on connection set either on the side or above the boiler). (Minimum system pressure > 1.0 bar).

Further details regarding the individual steps (cont.)

Note

If the control unit has not been switched on prior to filling the system, then the servomotor of the diverter valve will still be in its central position, and the system will be completely filled.

Note

Lever on valve (B) must be in the "l.h." position.

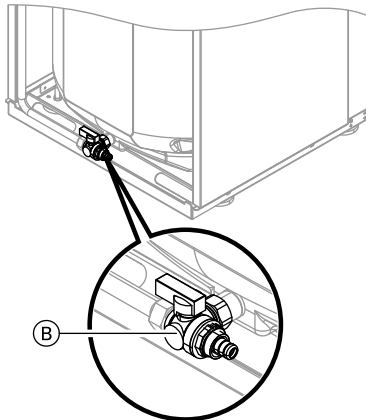

- If the control unit had already been switched on before filling began: Switch control unit ON and activate filling program (see next steps).

Note

For function and details of the fill program, see page 137.

- Close boiler drain & fill valve (A).

Activating the filling function:

- Press **OK** and **≡**: simultaneously for approx. 4 s.
- "Service functions"
- "Filling"
- Ending filling function:
Press **OK** or **↩**.

Changing the language (if required)

Note

At the commissioning stage, the display is in German (default setting)

Extended menu:

- ≡**
- "Settings"

- "Language"

Sprache	
Deutsch	DE <input checked="" type="checkbox"/>
Cesky	CZ <input type="checkbox"/>
Dansk	DK <input type="checkbox"/>
English	GB <input type="checkbox"/>
Wählen mit ↕	

- Set the required language with **▲/▼**.

Further details regarding the individual steps (cont.)

Setting the time and date (if required)

During commissioning, or after prolonged time out of use, the time and date need to be reset.

Extended menu:

1. ☰

2. "Settings"

3. "Time / Date"

4. Set current time and date.

Venting the boiler

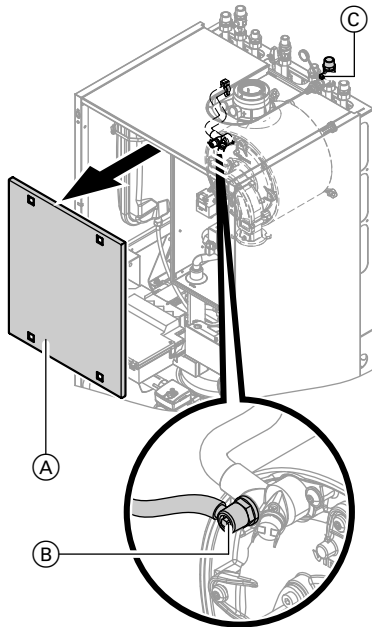

1. Close the shut-off valves on the heating water side.

2. Remove cover panel (A).

3. Connect the drain hose on air vent valve (B) with a drain.

4. Open air vent valve (B) and fill valve (C) in the heating return and vent using mains pressure (flush) until no more air noise can be heard.

5. Close air vent valve (B) and fill valve (C) in the heating return, and open the shut-off valves on the heating water side.

Venting the heating system

1. Close the gas shut-off valve and switch the control unit ON.

2. Activate venting program (see next steps).

Further details regarding the individual steps (cont.)

Note

For function and sequence of the venting program, see page 137.

3. Check the system pressure.

Activate venting program:

1. Press **OK** and  simultaneously for approx. 4 s.

2. "Service functions"

3. "Venting"

4. Terminating venting program:
Press **OK** or .

Filling siphon with water

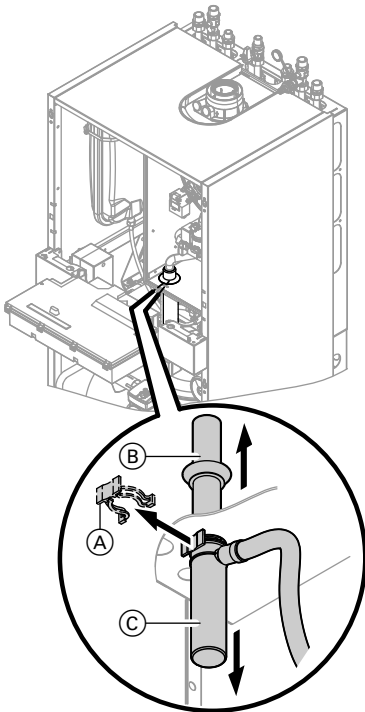

1. Pivot control unit forward.
2. Pull retaining clip (A) off.
3. Pull filler pipe (B) upwards.
4. Pull off trap (C) downwards.
5. Fill siphon with water and reassemble.
6. Refit cover panel.
7. Secure control unit back in operating position.

Further details regarding the individual steps (cont.)

Filling the solar circuit



Solar thermal system installation and service instructions

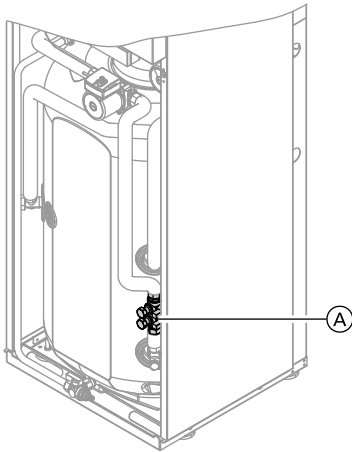

(A) Solar circuit fill valve



Please note

Overheated collector areas and overheated heat transfer medium can cause burns/scalding and equipment damage.

When working on the collector and the solar circuit, protect the collector area against solar irradiation.

1. Thoroughly flush the on-site pipe-work.

2. Fill the solar circuit via fill valve (A) with "Tyfocor LS".
Minimum system pressure: 1.7 bar.
Permiss. operating pressure: 6 bar.



Please note

To prevent equipment damage, use only "Tyfocor LS".
Never fill with water.

3. Close ball valve of fill valve (A).
4. Open the air vent valve at the solar collector.
5. Start solar circuit pump via a relay test (see page 101).
6. Let the solar circuit pump run until the solar circuit is fully vented. At a system pressure below 1.7 bar top up with "Tyfocor LS".
7. Close the air vent valve at the solar collector.
8. Check system pressure. Below 1.7 bar top up with "Tyfocor LS".

Further details regarding the individual steps (cont.)

Naming the heating circuits

In the delivered condition, the heating circuits are designated "**Heating circuit 1**", "**Heating circuit 2**" and "**Heating circuit 3**" (if installed).

If the system user prefers, the heating circuits can be designated differently to suit the specific system.



Enter names for heating circuits:

Operating instructions

Checking the gas type

The boiler is equipped with an electronic combustion controller that adjusts the burner for optimum combustion in accordance with the prevailing gas quality.

- Consequently, for natural gas there is no adjustment required across the entire Wobbe index range.

The boiler can be operated in the Wobbe index range 9.5 to 15.2 kWh/m³ (34.2 to 54.7 MJ/m³).

- Convert the burner for operation with LPG (see "Gas type conversion" on page 32).
1. Determine the gas type and Wobbe index by asking your local gas supply utility or LPG supplier.
 2. Convert the burner for operation with LPG (see page 32).
 3. Record the gas type in the service report on page 159.

Further details regarding the individual steps (cont.)

Gas type conversion (only for operation with LPG)

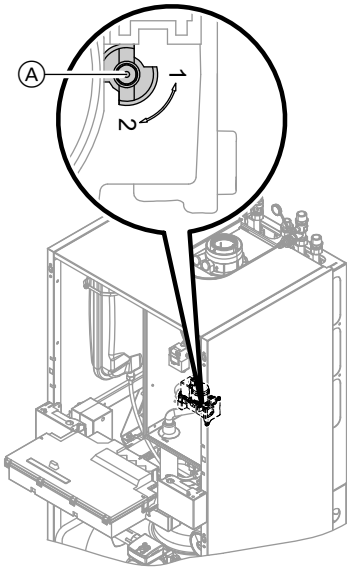

1. Set adjusting screw (A) on the gas train to "2".
2. Turn ON/OFF switch (I) ON.
3. Select the gas type in coding address "82":
 - Call up code 2
 - Call up **"General"**
 - In coding address "11", select value "9"
 - In coding address "82", select value "1" (LPG operation)
 - In code "11" select value ≠ "9".
 - End service functions.
4. Open the gas shut-off valve.
5. Affix label "G31" (supplied with the technical documentation) adjacent to the type plate on the cover panel.

Function sequence and possible faults

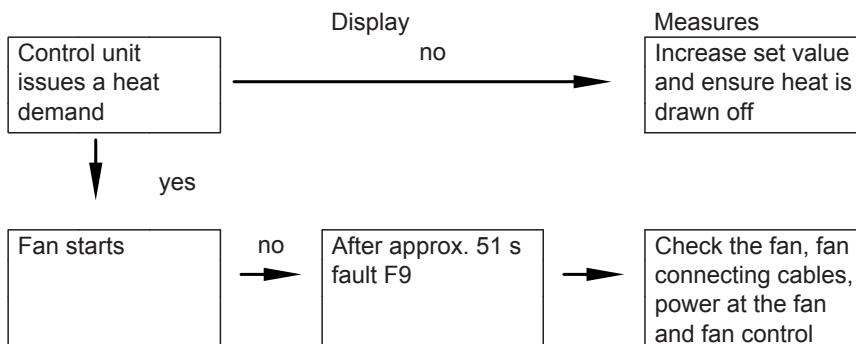

Further details regarding the individual steps (cont.)

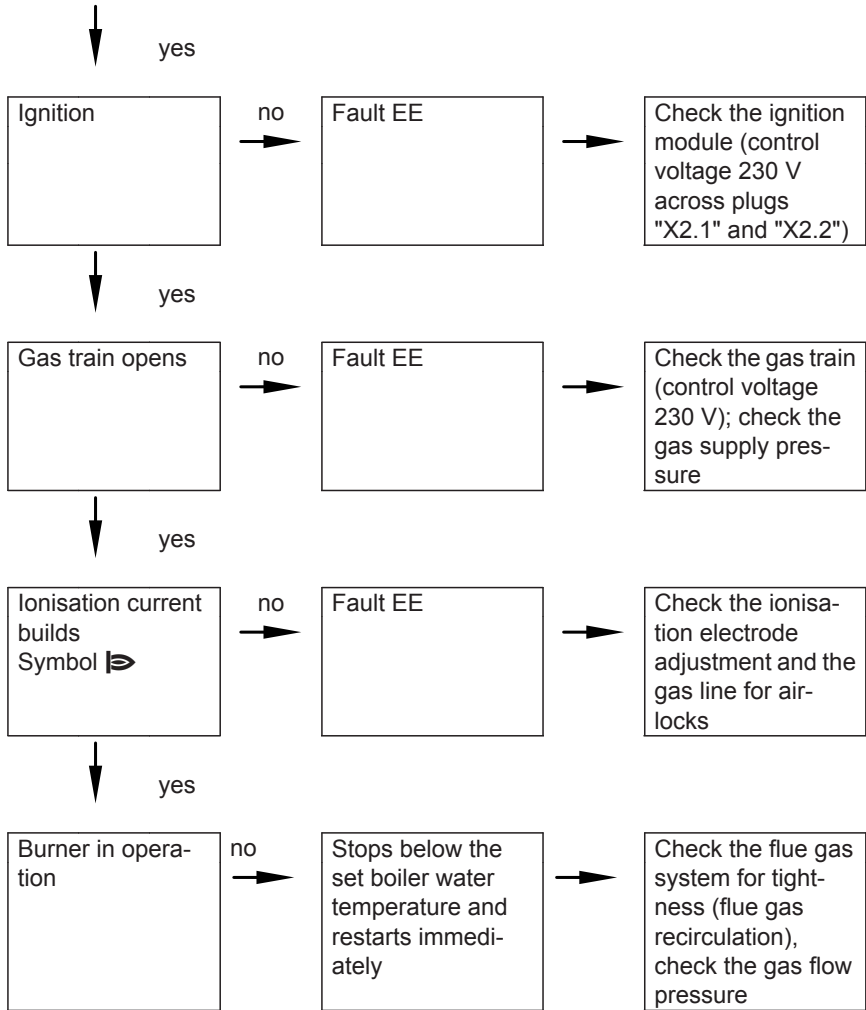

Service



Further details regarding the individual steps (cont.)

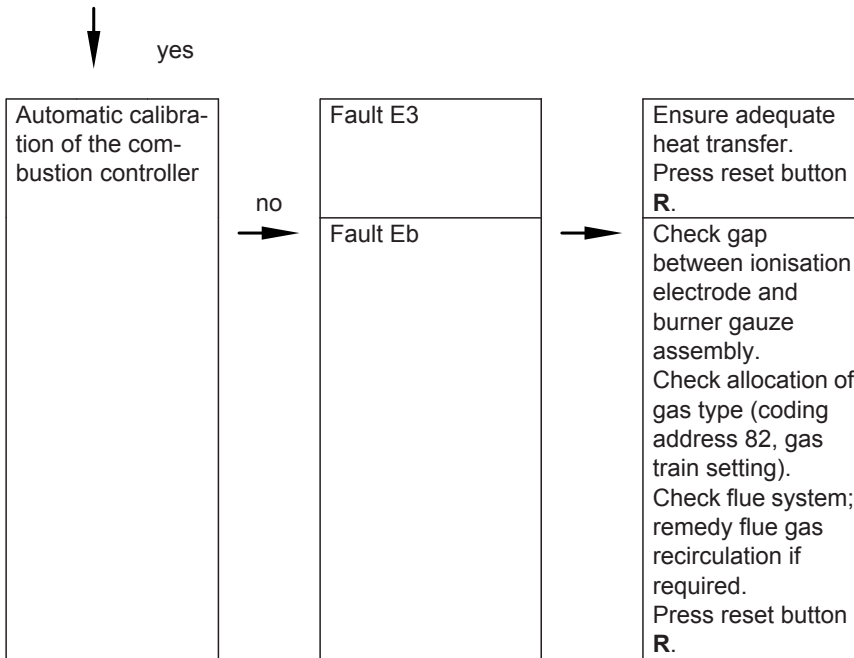

For further details regarding faults, see page 103.

Checking the static and supply pressure



Danger

CO build-up as a result of an incorrect burner setup can have serious health implications.

Carry out a CO test prior to and after work on gas equipment.

Operation with LPG

Flush the LPG tank twice during commissioning/replacement. Vent the tank and gas supply lines thoroughly after flushing.

Further details regarding the individual steps (cont.)

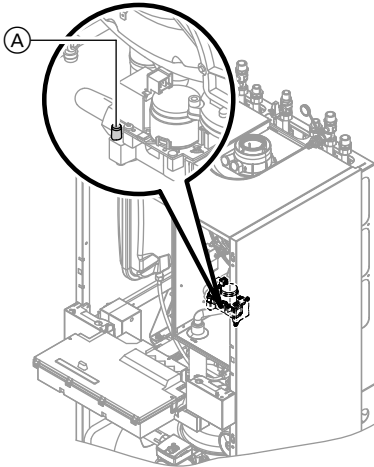

1. Close the gas shut-off valve.
2. Release the screw inside test nipple "PE" (A) on the gas train but do not remove it, then connect the pressure gauge.
3. Open the gas shut-off valve.
4. Check the static pressure and record it in the service report on page 159. Set value: max. 37 mbar
5. Start the boiler.

Note

During commissioning, the boiler can enter a fault state because of airlocks in the gas line. After approx. 5 s, press the reset button R (see operating instructions) to reset the burner.

6. Check the supply (flow) pressure.

Set value:

- Natural gas: 20 mbar
- LPG: 37 mbar

Note

Use suitable test equipment with a resolution of at least 0.1 mbar to check the supply pressure.

7. Record the actual values in the service report on page 159. Take the action shown in the following table.
8. Shut down the boiler, close the gas shut-off valve, remove the pressure gauge and close the screw in test nipple (A).
9. Open the gas shut-off valve and start the appliance.



Danger

Gas escaping from the test nipple leads to a risk of explosion. Check test nipple (A) for tightness.

Further details regarding the individual steps (cont.)

Supply (flow) pressure for natural gas	Supply (flow) pressure for LPG	Measures
below 15 mbar	below 25 mbar	Do not start the boiler. Notify your gas supply utility or LPG supplier.
15 to 25 mbar	25 to 45 mbar	Start the boiler.
above 25 mbar	above 45 mbar	Install a separate gas pressure governor upstream of the system and regulate the pre-charge pressure to 20 mbar for natural gas or 37 mbar for LPG. Notify your gas supply utility or LPG supplier.

Setting the maximum output

You can limit the maximum output for **heating operation**. The limit is set via the modulation range. The max. adjustable output is limited upwards by the boiler coding card.

1. Press **OK** and  simultaneously for approx. 4 s.
2. **"Service functions"**
3. **"Max. output"**
4. **"Change?"** Select **"Yes"**.
A value flashes on the display (e.g. "85"). In the delivered condition, this value represents 100 % of rated output.
5. Set the required value.

Further details regarding the individual steps (cont.)

Checking the balanced flue system tightness (annular gap check)

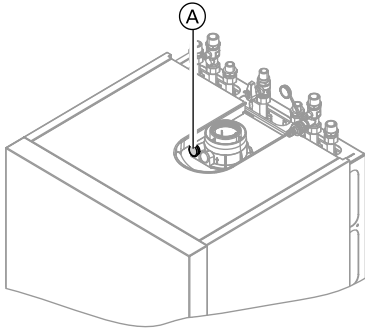

Ⓐ Combustion air aperture (ventilation air)

We recommend that your heating engineer carries out a simple leak/tightness test during the commissioning of your system. For this, it would be sufficient to check the CO₂ or O₂ concentration in the combustion air at the annular gap of the balanced flue pipe.

The flue pipe is deemed to be gas-tight if the CO₂ concentration in the combustion air is no higher than 0.2 % or the O₂ concentration is at least 20.6 %.

If actual CO₂ values are higher or O₂ values are lower, then pressure test the flue pipe with a static pressure of 200 Pa.

For balanced flue systems tested together with the wall mounted gas fired boiler, the requirement for a tightness test during commissioning by the flue gas inspector is not applicable.

Further details regarding the individual steps (cont.)

Removing the burner

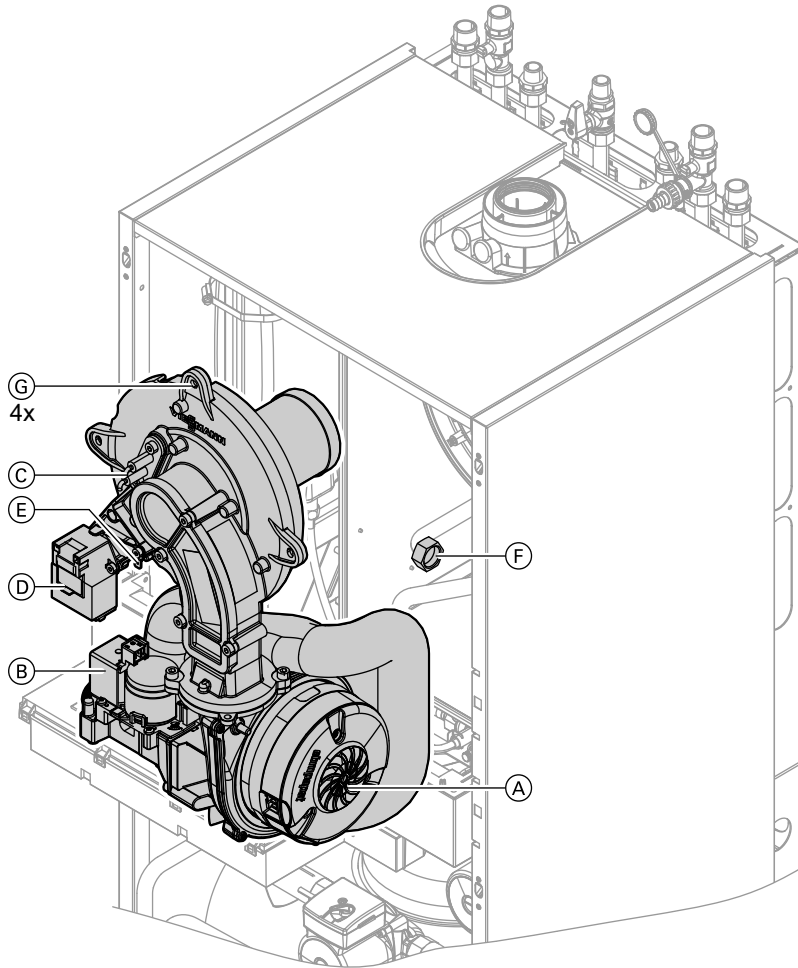

1. Switch OFF the main power supply and the ON/OFF switch  at the control unit.
2. Close the gas shut-off valve and safeguard against reopening.

Further details regarding the individual steps (cont.)

3. Pull electrical cables from fan motor (A), gas valve (B), ionisation electrode (C), ignition unit (D) and earth tab (E).
4. Release gas supply pipe fitting (F).
5. Undo four screws (G) and remove the burner.



Please note

Prevent damage to the wire gauze.
Never rest the burner on the gauze assembly!

Checking the burner gasket and burner gauze assembly

Check burner gasket (A) and burner gauze assembly (E) for damage; replace if required.

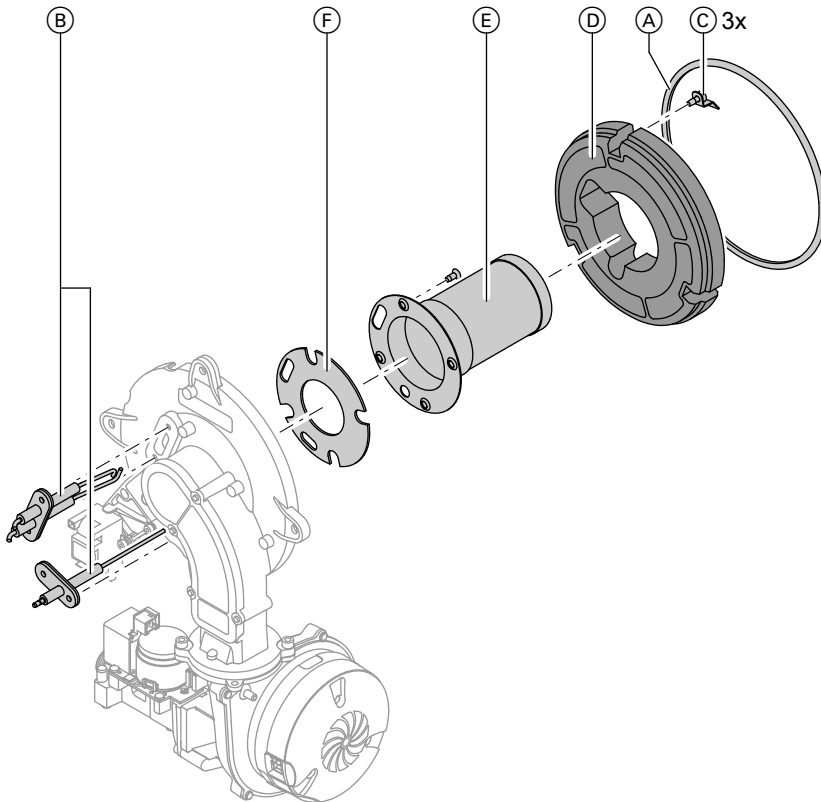

Further details regarding the individual steps (cont.)

1. Remove electrodes (B).
2. Undo three retaining clips (C) at thermal insulation ring (D) and remove thermal insulation ring (D).
3. Undo four Torx screws and remove burner gauze assembly (E) with its gasket (F).
4. Insert and secure a new burner gauze assembly (E) with a new gasket (F).
Torque: 3.5 Nm.
5. Refit thermal insulation ring (D).
6. Refit electrodes (B).
Torque: 4.5 Nm.

Checking and adjusting the ignition and ionisation electrodes

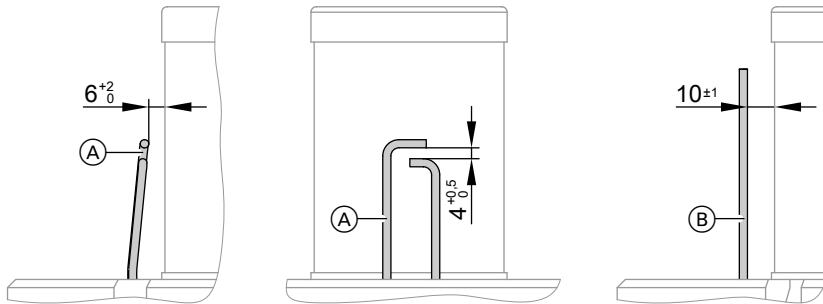

(A) Ignition electrodes

(B) Ionisation electrode

1. Check the electrodes for wear and contamination.
2. Clean the electrodes with a small brush (not with a wire brush) or sand paper.
3. Check the electrode gaps. If the gaps are not as specified or the electrodes are damaged, replace and align the electrodes together with new gaskets. Tighten the electrode fixing screws with 4.5 Nm torque.

Cleaning the heat exchanger and fitting the burner



Please note

Scratches on parts that are in contact with flue gas can lead to corrosion.
Never use brushes to clean the heat exchanger.

Further details regarding the individual steps (cont.)

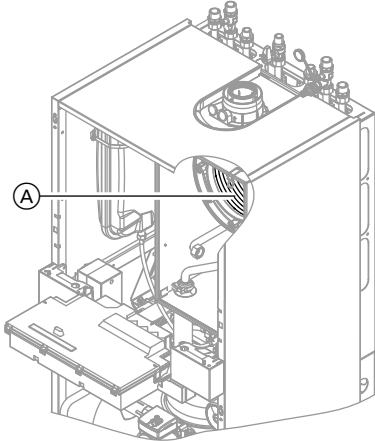

1. Use a vacuum cleaner to remove deposits from heat exchanger (A) inside the combustion chamber.
2. If required, spray slightly acidic, chloride-free cleaning agents based on phosphoric acid onto heat exchanger (A) and let the solution soak in for approx. 20 min.
3. Thoroughly flush heat exchanger (A) with water.
4. Install the burner. Fit the screw with a serrated washer as well as the remaining screws, then apply torque diagonally with 8.5 Nm.
5. Fit the gas supply pipe with a new gasket.
6. Check the gas connections for tightness.



Danger

Escaping gas leads to a risk of explosion.

Check all fittings for gas tightness.

7. Connect the electrical cables/leads to each corresponding component.

Further details regarding the individual steps (cont.)

Checking the condensate drain and cleaning the siphon

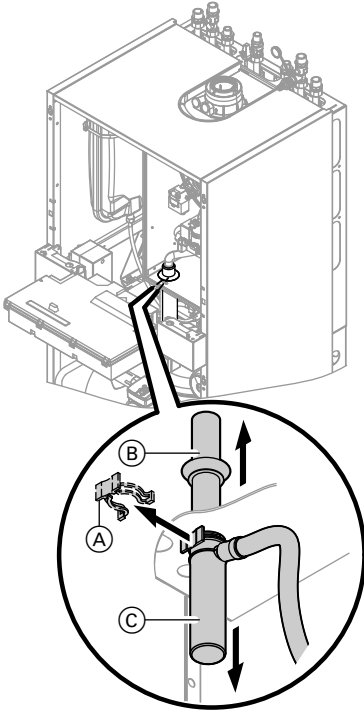

1. Check that the condensate can drain freely at the siphon.
2. Pull retaining clip (A) off.
3. Pull filler pipe (B) upwards.
4. Pull off trap (C) downwards.
5. Pull the condensate hose from trap (C).
6. Clean the siphon.
7. Fill siphon with water and reassemble.

Further details regarding the individual steps (cont.)

Checking the anode connection

Check that the earth lead is connected to the magnesium anode.

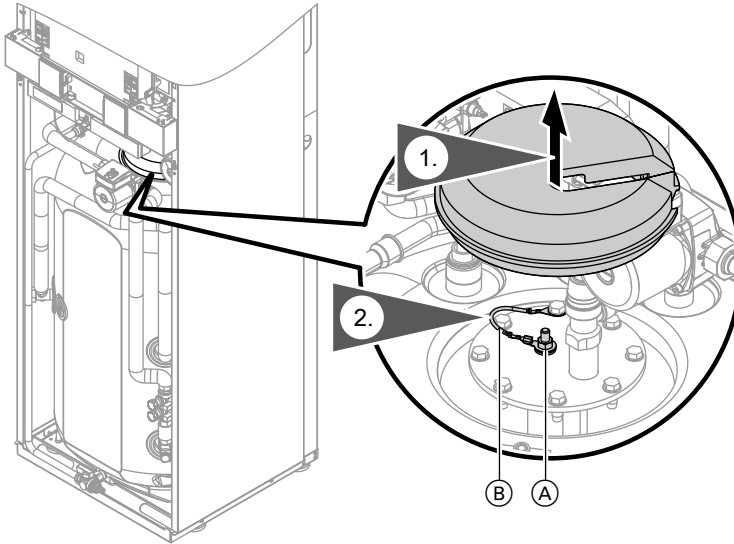

Ⓐ Magnesium anode

Ⓑ Earth cable

Testing the anode earth current with an anode tester

Note

We recommend that the magnesium anode function is checked annually. This function test can be carried out without interrupting operation, by measuring the earth current with an anode tester.

Further details regarding the individual steps (cont.)

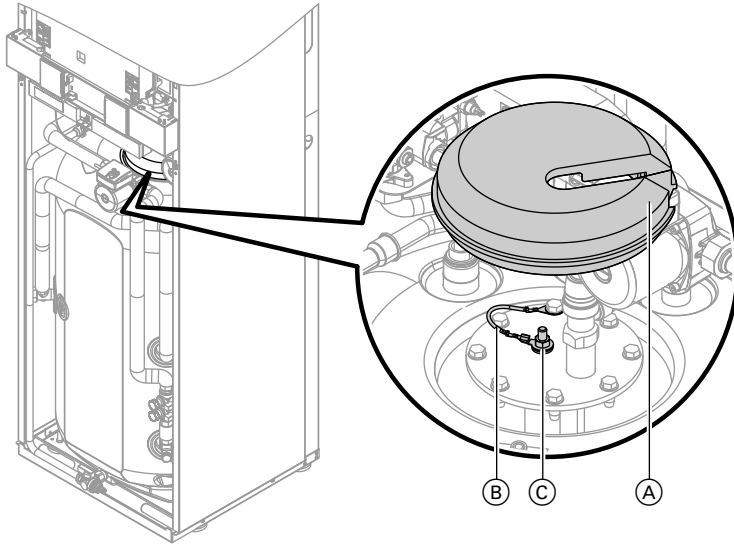

1. Remove cover (A).
2. Pull earth lead (B) from tab (C).
3. Connect the tester (up to 5 mA) in series between tab (C) and earth cable (B).
 - The anode is OK if the indicated current is > 0.3 mA.
 - Visually inspect the anode if the current measures < 0.3 mA, or if there is no current at all (see page 47).

Further details regarding the individual steps (cont.)

Draining the boiler on the DHW side

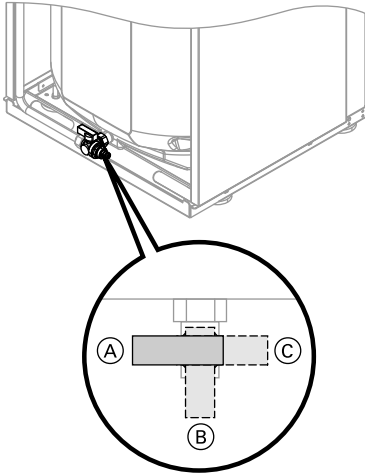

1. Connect hose to drain valve and route into a suitable container or drain outlet.

Note

Ensure adequate ventilation in the DHW pipework.

2. Turn drain valve from lever position (A) to lever position (B) or (C) as required.
 - Lever position (B): Drain heating system **excluding** cylinder via the cold water connection.
 - Lever position (C): Drain heating system **and** cylinder via the DHW connection. Cold water connection remains filled.

Further details regarding the individual steps (cont.)

Cleaning the primary store

Note

EN 806 specifies a visual inspection and (if required) cleaning every two years after commissioning and thereafter according to requirements.

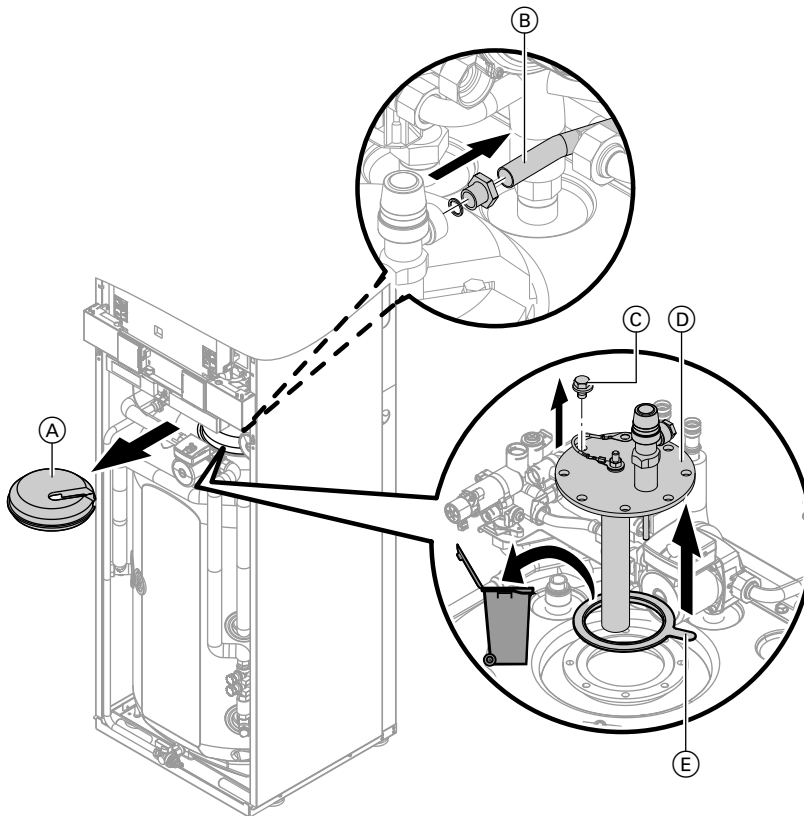

1. Drain the primary store.
2. Remove flange lid (A).
3. Remove T&P valve (B).
4. Undo eight screws (C) and remove flange lid (D).
5. Dispose of gasket (E).
6. Disconnect the primary store from the pipework to prevent contamination from entering the pipe system.

Further details regarding the individual steps (cont.)

7. Remove loose deposits with a high pressure cleaner.
9. Thoroughly flush the primary store after cleaning.

! **Please note**
When cleaning the inside, only use plastic cleaning utensils.

8. Use a chemical cleaning agent to remove hard deposits that cannot be removed by a high pressure cleaner.

! **Please note**
Never use hydrochloric acid based cleaning agents.

Checking and replacing the magnesium anode (if required)

Check the magnesium anode. If the anode is found to have degraded to 10 to 15 mm Ø, we recommend replacing the magnesium anode.

Further details regarding the individual steps (cont.)

Returning the primary store into use

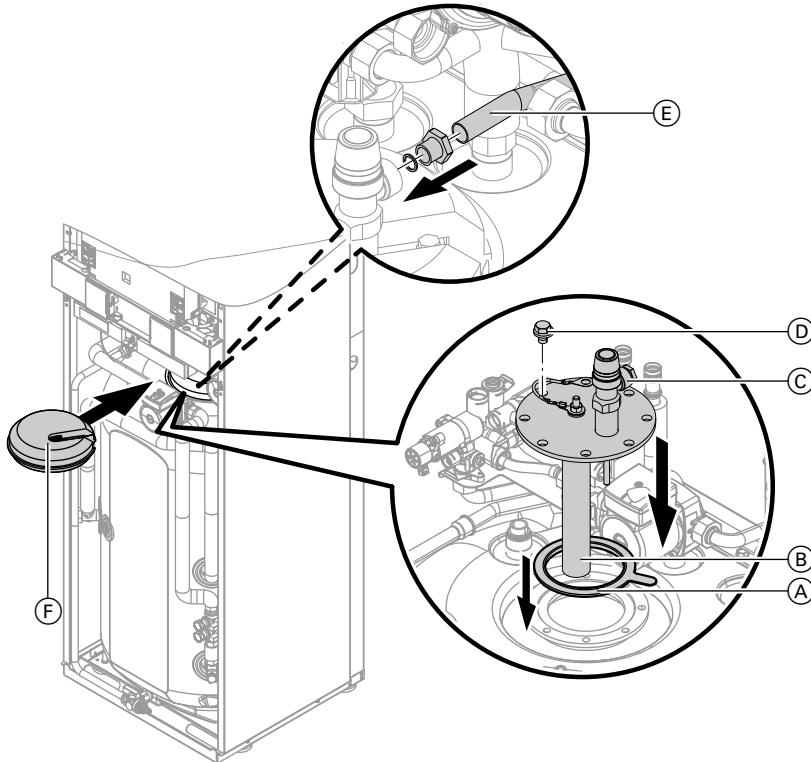

1. Reconnect the primary store to the pipework.
2. Insert new gasket (A) underneath flange lid (B).
3. Fit flange lid (B) and tighten eight screws (D) with up to 25 Nm torque.
4. Push earth cable (C) onto the tab.
5. Fit T&P valve (E).
6. Fit cover (F).
7. Fill the primary store with drinking water.

Further details regarding the individual steps (cont.)

Checking the diaphragm expansion vessel and system pressure

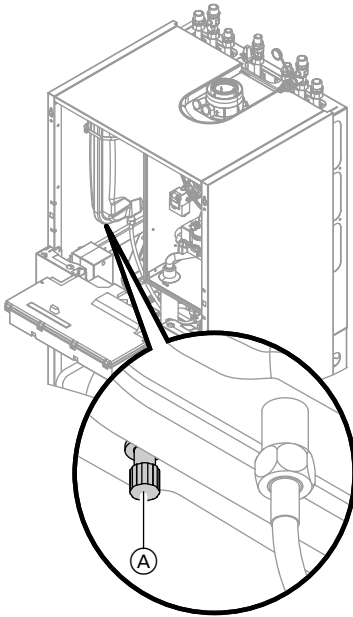

Note

Carry out this test on a cold system.

1. Drain the system, until the pressure gauge indicates "0".
2. If the diaphragm expansion vessel inlet pressure is lower than the static system pressure: Top up with nitrogen via connection (A), until the inlet pressure is 0.1 to 0.2 bar.
3. Top up your heating system with water and vent until the filling pressure of a cooled system is 0.1 to 0.2 bar higher than the inlet pressure of the diaphragm expansion vessel.
Permiss. operating pressure: 3 bar

Checking gas equipment for tightness at operating pressure



Danger

Escaping gas leads to a risk of explosion.
Check gas equipment for tightness.

Note

For the tightness test, use only suitable and approved leak detecting agents (EN 14291) and devices. Leak detecting agents with unsuitable contents (e.g. nitrides, sulphides) can lead to material damage.

Remove residues of the leak detecting agent after testing.

Further details regarding the individual steps (cont.)

Checking the combustion quality

The electronic combustion controller automatically ensures an optimum combustion quality. The combustion values only need to be checked during commissioning and service. For this, check the CO₂ or O₂ content. For a description of the electronic combustion controller functions, see page 143.



Please note

- To prevent operating faults and equipment damage, never operate with dirty combustion air.

CO₂ or O₂ content

- The CO₂ content must be within the following limits for the upper and lower output:
 - 7.7 to 9.2 % for natural gas H
 - 9.3 to 10.9 % for LPG P
- For all gas types, the O₂ content must be between 4.4 and 6.9 %.

If the actual CO₂ or O₂ values lie outside their respective ranges, proceed with the following steps:

- Checking the balanced flue system for tightness, see page 37.
- Checking the ionisation electrode and connecting cable, see page 40.

Note

During commissioning, the combustion controller carries out an automatic calibration. Only test the emissions approx. 30 s after the burner has started.

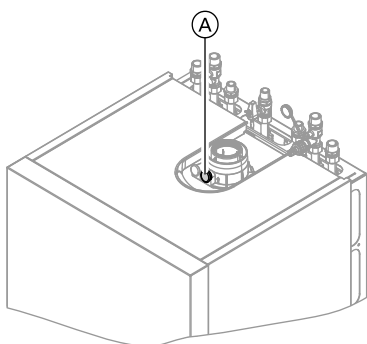

1. Connect a flue gas analyser at flue gas aperture (A) on the boiler flue connection.

2. Open the gas shut-off valve, start the boiler and create a heat demand.
3. Select the lower output (see page 51).
4. Check the CO₂ content. Should the actual value deviate from the above ranges by more than 1 %, implement steps from page 50.
5. Enter actual values into the service report.
6. Select the upper output (see page 51).

Further details regarding the individual steps (cont.)

7. Check the CO₂ content. Should the actual value deviate from the above ranges by more than 1 %, implement steps from page 50.
8. After testing, press **OK**.
9. Enter actual values into the service report.
2. **"Actuator test"**
3. Select the lower output:
Select **"Base load" "ON"** and confirm with **OK**.
4. Select the upper output:
Select **"Full load" "ON"** and confirm with **OK**.

To set the upper/lower output:

1. Press **OK** and **≡**: simultaneously for approx. 4 s.

Matching the control unit to the heating system

Subject to the equipment level, the control unit must be matched to the system. Various system components are recognised automatically by the control unit and the relevant codes are adjusted automatically.

- For the selection of an appropriate scheme, see the following diagrams.
- For coding steps, see page 66.

Further details regarding the individual steps (cont.)

System version 1

One heating circuit without mixer A1

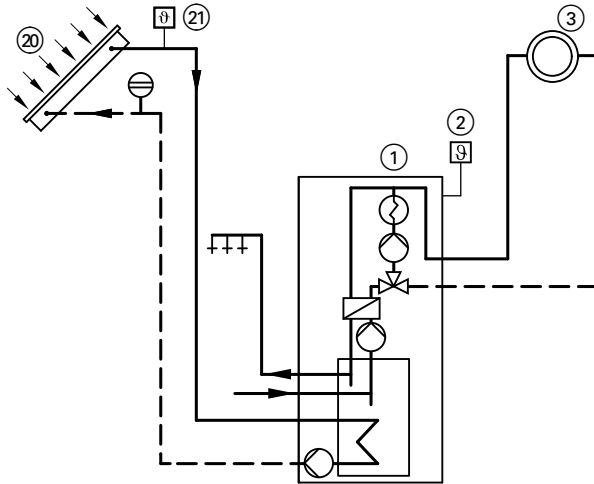

- ① Vitodens 242-F
- ② Outside temperature sensor
- ③ Heating circuit without mixer A1
- ②① Solar collectors
- ②① Collector temperature sensor

Function/system components	Code	
	Adjust	Delivered condition
Operation with LPG	82:1	82:0
System with DHW circulation pump: DHW circulation pump connection at extension AM1, terminal A2	—	34:0

Further details regarding the individual steps (cont.)

System version 2

One heating circuit with mixer M2 and a low loss header

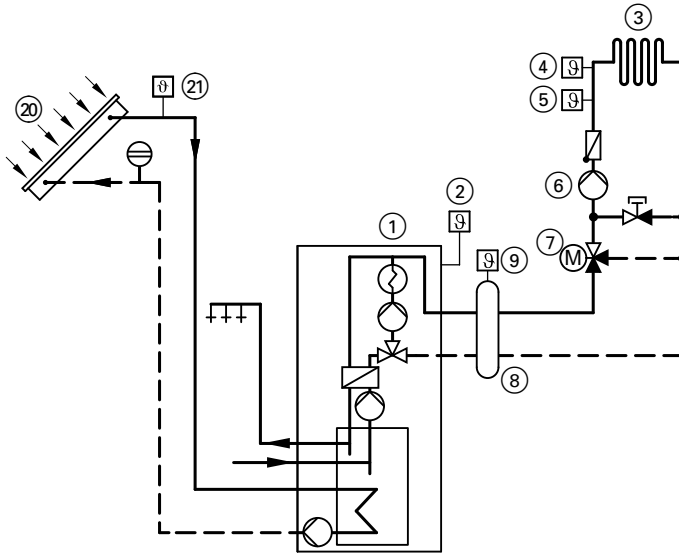

- ① Vitodens 242-F
- ② Outside temperature sensor
- ③ Heating circuit with mixer M2
- ④ Temperature limiter for limiting the maximum temperature of underfloor heating systems
- ⑤ Flow temperature sensor M2
- ⑥ Heating circuit pump M2
- ⑦ Extension kit for one heating circuit with mixer M2
- ⑧ Low loss header
- ⑨ Flow temperature sensor, low loss header
- ⑩ Solar collectors
- ⑪ Collector temperature sensor

Function/system components	Code	
	Adjust	Delivered condition
Operation with LPG	82:1	82:0
System only with one heating circuit with mixer with extension kit for mixer with DHW heating	00:4	00:6
System with DHW circulation pump:		

Further details regarding the individual steps (cont.)

Function/system components	Code	
	Adjust	Delivered condition
DHW circulation pump connection at extension AM1, terminal A2	—	34:0
System with low loss header	04:0	04:1

System version 3

One heating circuit without mixer A1 and one heating circuit with mixer M2

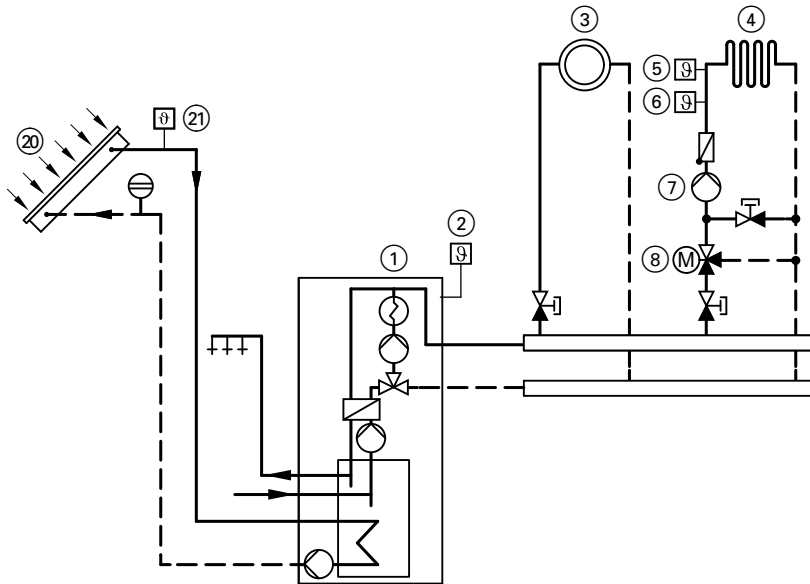

- ① Vitodens 242-F
- ② Outside temperature sensor
- ③ Heating circuit without mixer A1
- ④ Heating circuit with mixer M2
- ⑤ Temperature limiter for limiting the maximum temperature of underfloor heating systems
- ⑥ Flow temperature sensor M2
- ⑦ Heating circuit pump M2
- ⑧ Extension kit for one heating circuit with mixer M2
- ⑩ Solar collectors
- ⑪ Collector temperature sensor

Further details regarding the individual steps (cont.)

Note

The flow rate of the heating circuit without mixer must be at least 30 % greater than the flow rate of the heating circuit with mixer.

Function/system components	Code	
	Adjust	Delivered condition
Operation with LPG	82:1	82:0
System only with one heating circuit with mixer with extension kit for mixer with DHW heating	00:4	00:6
System with DHW circulation pump: DHW circulation pump connection at extension AM1, terminal A2	—	34:0

Further details regarding the individual steps (cont.)

System version 4

One heating circuit without mixer A1, one heating circuit with mixer M2 and system separation

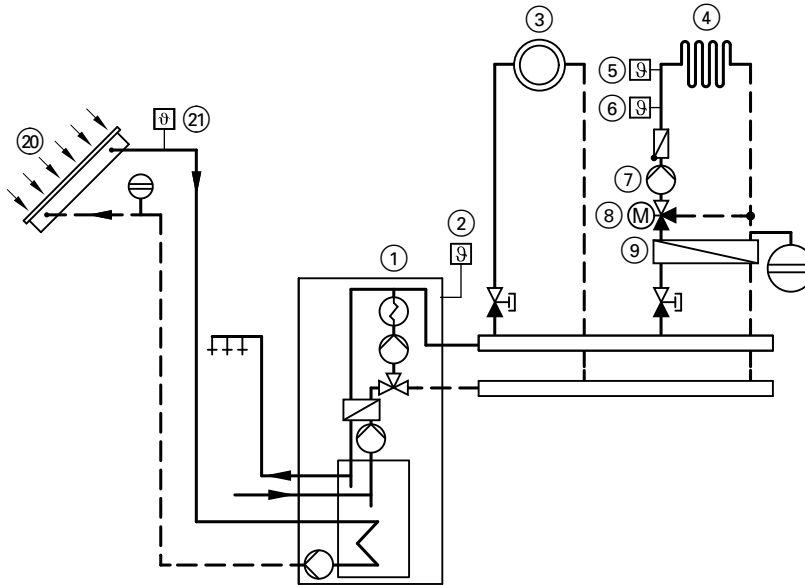

- ① Vitodens 242-F
- ② Outside temperature sensor
- ③ Heating circuit without mixer A1
- ④ Heating circuit with mixer M2
- ⑤ Temperature limiter for limiting the maximum temperature of underfloor heating systems
- ⑥ Flow temperature sensor M2
- ⑦ Heating circuit pump M2
- ⑧ Extension kit for one heating circuit with mixer M2
- ⑨ Heat exchanger for system separation
- ⑩ Solar collectors
- ⑪ Collector temperature sensor

Function/system components	Code	
	Adjust	Delivered condition
Operation with LPG	82:1	82:0
System only with one heating circuit with mixer with extension kit for mixer with DHW heating	00:4	00:6

Further details regarding the individual steps (cont.)

Function/system components	Code	
	Adjust	Delivered condition
System with DHW circulation pump: DHW circulation pump connection at extension AM1, terminal A2	—	34:0

System version 5

One heating circuit without mixer A1, one heating circuit with mixer M2 (with extension kit), one heating circuit with mixer M3 (with extension kit) and low loss header (with/without DHW heating)

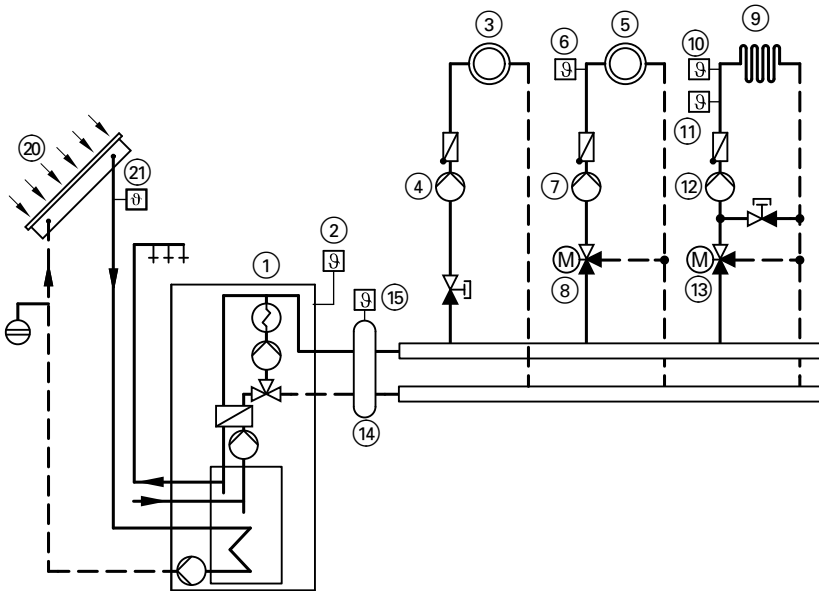

- ① Vitodens 242-F
- ② Outside temperature sensor
- ③ Heating circuit without mixer A1 (heating circuit 1)
- ④ Heating circuit pump A1
- ⑤ Heating circuit with mixer M2 (heating circuit 2)
- ⑥ Flow temperature sensor M2
- ⑦ Heating circuit pump M2
- ⑧ Extension kit for one heating circuit with mixer M2
- ⑨ Heating circuit with mixer M3 (heating circuit 3)
- ⑩ Temperature limiter for limiting the maximum temperature of underfloor heating systems

5412 755 GB

Service



Further details regarding the individual steps (cont.)

- | | |
|---|--|
| ⑪ Flow temperature sensor M3 | ⑮ Flow temperature sensor, low loss header |
| ⑫ Heating circuit pump M3 | ⑯ Solar collectors |
| ⑬ Extension kit for one heating circuit with mixer M3 | ⑰ Collector temperature sensor |
| ⑭ Low loss header | |

Function/system components	Code	
	Adjust	Delivered condition
Operation with LPG	82:1	82:0
System only with two heating circuits with mixer with extension kit for mixer with DHW heating	00:8	00:10
System without DHW circulation pump: Heating circuit pump A1 connection at extension AM1, terminal A1	—	33:1
System with DHW circulation pump: Heating circuit pump A1 connection at extension AM1, terminal A1	—	33:1
DHW circulation pump connection at extension AM1, terminal A2	—	34:0
System with low loss header	04:0	04:1

Adjusting the heating curves

The heating curves illustrate the relationship between the outside temperature and the boiler water or flow temperature.

To put it simply, the lower the outside temperature, the higher the boiler water or flow temperature.

The room temperature, again, depends on the boiler water or the flow temperature.

Note

If the heating system includes heating circuits with mixers, then the flow temperature of the heating circuit without mixer is higher by a selected differential (8 K in the delivered condition) than the flow temperature of the heating circuits with mixers.

The differential temperature can be changed at coding address 9F.

Settings in the delivered condition:

- Slope = 1.4
- Level = 0

Further details regarding the individual steps (cont.)

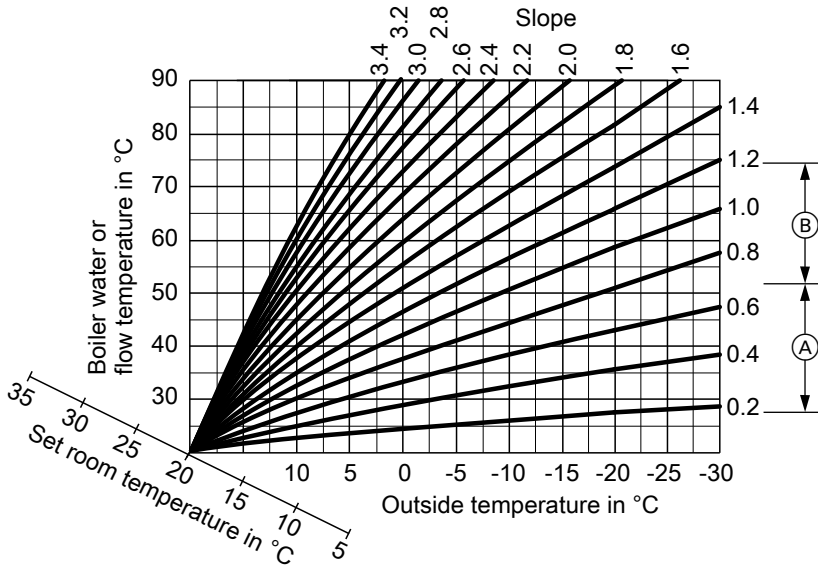

- Ⓐ Heating curve slope for underfloor heating systems
- Ⓑ Heating curve slope for low temperature heating systems (according to the Energy Savings Order [Germany])

Further details regarding the individual steps (cont.)

Changing the slope and level

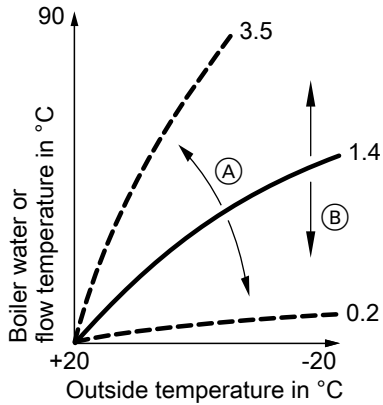

- Ⓐ Changing the slope
- Ⓑ Changing the level (vertical parallel offset of the heating curve)

Extended menu:

- 1.
2. "Heating"
3. Select heating circuit.
4. "Heating curve"
5. "Slope" or "Level"
6. Select heating curve according to the system requirements.

Adjusting the set room temperature

Standard room temperature

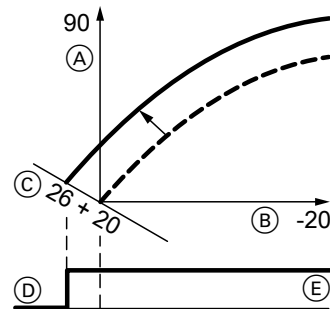

Example 1: Adjustment of the standard room temperature from 20 to 26°C

- Ⓐ Boiler water temperature or flow temperature in °C
- Ⓑ Outside temperature in °C
- Ⓒ Set room temperature in °C
- Ⓓ Heating circuit pump "OFF"
- Ⓔ Heating circuit pump "ON"

Adjustment of the standard room temperature:

Operating instructions

Further details regarding the individual steps (cont.)

Reduced room temperature

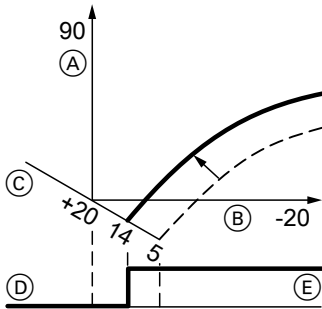

- (C) Set room temperature in °C
- (D) Heating circuit pump "OFF"
- (E) Heating circuit pump "ON"

Adjustment of the reduced room temperature:



Operating instructions

Example 2: Adjustment of reduced room temperature from 5 °C to 14 °C

- (A) Boiler water temperature or flow temperature in °C
- (B) Outside temperature in °C

Connecting the control unit to the LON

The LON communication module (accessories) must be plugged in.



Installation instructions
LON communication module

Note

The data transfer via LON can take several minutes.

Single boiler system with Vitotronic 200-H and Vitocom 300 (example)



Set the LON subscriber numbers and further functions via code 2 (see the following table).

Note

In the same LON system, the same number **cannot** be allocated twice.

Only one Vitotronic may be programmed as fault manager.

Further details regarding the individual steps (cont.)

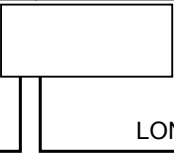
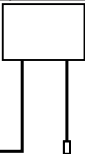
Boiler control unit	Vitotronic 200-H	Vitotronic 200-H	Vitocom
			
Subscriber no. 1 Code "77:1"	Subscriber no. 10 Code "77:10"	Subscriber no. 11 Set code "77:11"	Subscriber no. 99
Control unit is fault manager Code "79:1"	Control unit is not fault manager Code "79:0"	Control unit is not fault manager Code "79:0"	Device is fault manager
Control unit transmits the time Code "7b:1"	The control unit receives the time Set code "81:3"	The control unit receives the time Set code "81:3"	Device receives the time
Control unit transmits outside temperature Set code "97:2"	The control unit receives the outside temperature Set code "97:1"	The control unit receives the outside temperature Set code "97:1"	—
LON subscriber fault monitoring Code "9C:20"	LON subscriber fault monitoring Code "9C:20"	LON subscriber fault monitoring Code "9C:20"	—

Carrying out a LON subscriber check

Communication with the system devices connected to the fault manager is tested with a subscriber check.

Preconditions:

- The control unit must be programmed as **fault manager** (code "79:1")
- The LON subscriber number must be programmed in all control units (see page 62)
- The LON subscriber list in the fault manager must be up to date (see page 62)

2. "Service functions"

3. "Subscriber check"

Carrying out a subscriber check:

1. Press **OK** and  simultaneously for approx. 4 s.

Further details regarding the individual steps (cont.)

4. Select subscriber (e.g. subscriber 10).
The subscriber check for the selected subscriber is introduced.
 - Successfully tested subscribers are designated with **"OK"**.
 - Unsuccessfully tested subscribers are designated with **"Not OK"**.

Note

*To carry out a new subscriber check, create a new subscriber list with menu item **"Delete list?"***

Note

*If the subscriber check is carried out by another control unit, the subscriber number and **"Wink"** are shown on the display for approx. 1 min.*

Scanning and resetting the "Service" display

After the limit values specified in coding address "21" and "23" have been reached, "Service" and "🔧" appear on the programming unit display.

Acknowledging and resetting service

Press **OK** to acknowledge a service message.

Note

An acknowledged service message that was not reset reappears the following Monday.

After a service has been carried out (reset service)

1. Press **OK** and **≡** simultaneously for approx. 4 s.

2. "Service functions"

3. "Service reset"

Note

The selected service parameters for hours run and time interval restart at 0.

Further details regarding the individual steps (cont.)

Fitting the front panels

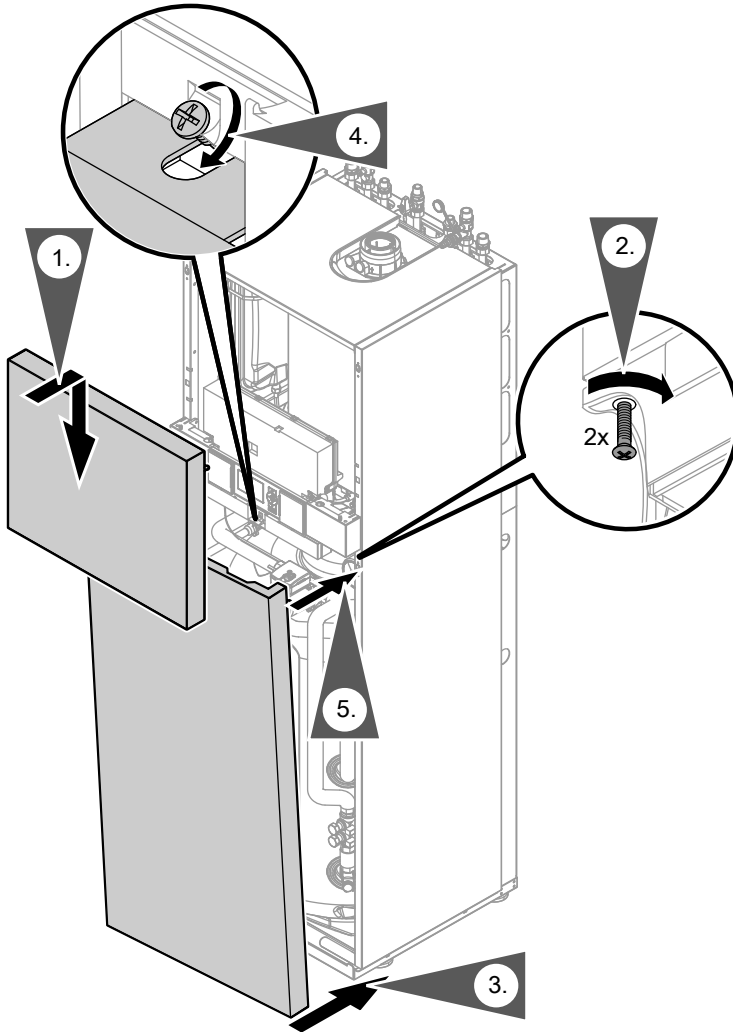

Further details regarding the individual steps (cont.)

Instructing the system user

The system installer must hand the operating instructions to the system user and instruct him/her in the operation of the system.

Calling up coding level 1

Note

- *The codes are displayed as plain text.*
- *Codes that have no function due to the heating system equipment level or the setting of other codes are not displayed.*
- *Heating systems with one heating circuit without mixer and one or two heating circuits with mixer:
The heating circuit without mixer is designated "**Heating circuit 1**" and the heating circuits with mixer as "**Heating circuit 2**" or "**Heating circuit 3**".
If the heating circuits were given individual designations, the selected designation and "**HC1**", "**HC2**" or "**HC3**" appear instead.*

1. Press **OK** and **≡**; simultaneously for approx. 4 s.

2. "Coding level 1"

3. Select group of required coding address:

- **"General"**
- **"Boiler"**
- **"DHW"**
- **"Solar"**
- **"Heating circuit 1/2/3"**
- **"All cod. or solar"**

In this group, all coding addresses from coding level 1 (except the coding addresses from the **"Solar"** group) are displayed in ascending order.

4. Select coding address.

5. Select value according to the following tables and confirm with **OK**.

6. **If you want to reset all codes to their delivered condition:**
Select **"Standard setting"** in **"Coding level 1"**.

Note

This also resets codes from coding level 2.

General

Coding

Coding in the delivered condition		Possible change	
System design			
00:2	System version 1: One heating circuit without mixer (A1), with DHW heating	00:2 to 00:10	For system schemes, see the following table:

Value address 00: ...	System version	Description
2	1	One heating circuit without mixer A1 (heating circuit 1), with DHW heating (code is adjusted automatically)
4	2	One heating circuit with mixer M2 (heating circuit 2), with DHW heating
6	3, 4	One heating circuit without mixer A1 (heating circuit 1) and one heating circuit with mixer M2 (heating circuit 2), with DHW heating (code is adjusted automatically)
8	5	One heating circuit with mixer M2 (heating circuit 2) and one heating circuit with mixer M3 (heating circuit 3), with DHW heating
10	5	One heating circuit without mixer A1 (heating circuit 1), one heating circuit with mixer M2 (heating circuit 2) and one heating circuit with mixer M3 (heating circuit 3), with DHW heating (code is adjusted automatically)

General (cont.)

Coding in the delivered condition		Possible change	
Internal circulation pump function			
51:0	System with low loss header: Internal circulation pump always starts when there is a heat demand.	51:1	System with low loss header: When there is a heat demand, the internal circulation pump will only be started when the burner is operational.
		51:2	System with heating water buffer cylinder: When there is a heat demand, the internal circulation pump will only be started when the burner is operational.
Subscriber no.			
77:1	LON subscriber number	77:2 to 77:99	LON subscriber number, adjustable from 1 to 99: 1 - 4 = Boiler 5 = Cascade 10 - 98 = Vitotronic 200-H 99 = Vitocom Note <i>Allocate each number only once.</i>
Detached house/apartment building			
7F:1	Detached house	7F:0	Apartment building Separate adjustment of holiday program and time program for DHW heating, as option
Lock out controls			
8F:0	All control elements active	8F:1	All control elements locked out
		8F:2	Only standard settings can be controlled

General (cont.)

Coding in the delivered condition		Possible change	
Set flow temperature in case of ext. Demand			
9b:70	Set flow temperature for external demand 70 °C	9b:0 to 9b:127	Set flow temperature for external demand adjustable from 0 to 127 °C (limited by boiler-specific parameters)

Select boiler**Coding**

Coding in the delivered condition		Possible change	
Burner service in 100 hours			
21:0	No service interval (hours run) selected	21:1 to 21:100	The number of hours run before the burner should be serviced is adjustable from 100 to 10,000 h One adjusting step $\hat{=}$ 100 h
Service interval in months			
23:0	No time interval for burner service	23:1 to 23:24	Interval adjustable from 1 to 24 months
Service status			
24:0	No "Service" display	24:1	"Service" display (the address is automatically set and must be manually reset after a service has been carried out)
Filling/Venting			
2F:0	Venting program/fill program disabled	2F:1	Venting program enabled
		2F:2	Fill program enabled

Code 1

DHW

Coding

Coding in the delivered condition		Possible change	
Set DHW temp reheat suppression			
67:40	For solar DHW heating: set DHW temperature 40 °C. Reheating of DHW is suppressed above the selected set temperature.	67:0 to 67:95	Set DHW temperature adjustable from 0 to 95 °C (limited by boiler-specific parameters)
Enable DHW circulation pump			
73:0	DHW circulation pump: "ON" according to time program	73:1 to 73:6	"ON" from once per hour for 5 min up to 6 times per hour for 5 min during the time program
		73:7	Constantly "ON"

Solar

Coding

Coding in the delivered condition		Possible change	
Speed control collector pump			
02:1	Solar circuit pump (multi-stage) is speed-controlled with wave pack control	02:0	Solar circuit pump (multi-stage) is not speed-controlled
		02:2	Do not adjust
Cylinder maximum temperature			
08:60	The solar circuit pump will stop when the actual cylinder temperature reaches 60 °C (maximum cylinder temperature).	08:10 to 08:90	The maximum cylinder temperature can be adjusted from 10 to 90 °C

Solar (cont.)

Coding in the delivered condition		Possible change	
Reducing stagnation time			
0A:5	To protect the system components and heat transfer medium, the speed of the solar circuit pump is reduced when the differential between the actual cylinder temperature and set cylinder temperature is less than 5 K.	0A:0 to 0A:40	The differential between the set cylinder temperature and the start point for reducing the stagnation time can be adjusted from 0 to 40 K.
Nominal flow rate			
0F:70	The flow rate in the collector circuit at the maximum pump speed is set to 7 l/min.	0F:1 to 0F:255	Flow rate in the collector circuit adjustable from 0.1 to 25,5 l/min

Heating circuit 1, heating circuit 2, heating circuit 3**Coding**

Coding in the delivered condition		Possible change	
Summer eco function outside temperature			
A5:5	With heating circuit pump logic function (economy circuit): Heating circuit pump "OFF" when the outside temperature (AT) is 1 K higher than the set room temperature (RT_{set}) $AT > RT_{set} + 1 K$	A5:0	Without heating circuit pump logic function
		A5:1 to A5:15	With heating circuit pump logic function: Heating circuit pump "OFF"; see the following table

Parameter address	With heating circuit pump logic function: Heating circuit pump "OFF"
A5:...	
1	$AT > RT_{set} + 5 K$
2	$AT > RT_{set} + 4 K$
3	$AT > RT_{set} + 3 K$
4	$AT > RT_{set} + 2 K$



Heating circuit 1, heating circuit 2, heating... (cont.)

Parameter address A5:...	With heating circuit pump logic function: Heating circuit pump "OFF"
5	$AT > RT_{\text{set}} + 1 \text{ K}$
6	$AT > RT_{\text{set}}$
7	$AT > RT_{\text{set}} - 1 \text{ K}$
to	
15	$AT > RT_{\text{set}} - 9 \text{ K}$

Coding in the delivered condition	Possible change
-----------------------------------	-----------------

Summer eco function absolute

A6:36	Extended economy mode disabled	A6:5 to A6:35	Extended economy control enabled, i.e. the burner and heating circuit pump will stop and the mixer close at a variable value, adjustable between 5 and 35 °C plus 1 °C. The base value is the adjusted outside temperature. This value is based on the actual outside temperature and a time constant that takes the cooling down of an average building into consideration.
-------	--	---------------------	--

Mixer eco function

A7:0	Without mixer economy function (only for heating circuits with mixer)	A7:1	With mixer economy function (extended heating circuit pump logic): Heating circuit pump also "OFF": <ul style="list-style-type: none"> ■ If a mixer has been attempting to close for longer than 20 min. Heating circuit pump "ON": <ul style="list-style-type: none"> ■ If the mixer changes to control function ■ If there is a risk of frost
------	---	------	---

Heating circuit 1, heating circuit 2, heating... (cont.)

Coding in the delivered condition		Possible change	
Pump idle time transition red. mode			
A9:7	With pump idle time: Heating circuit pump "OFF" in case of set value modification by changing the operating mode or changing the set room temperature	A9:0	Without pump idle time
		A9:1 to A9:15	With pump idle time; adjustable from 1 to 15
Weather-compensated/room temperature hook-up			
b0:0	With remote control: Heating mode/reduced mode: weather-compen- sated (change code only for the heating circuit with mixer)	b0:1	Heating mode: weather- compensated Reduced mode: with room temperature hook-up
		b0:2	Heating mode: with room temperature hook-up Reduced mode: weather- compensated
		b0:3	Heating mode/reduced mode: with room tempera- ture hook-up
Summer eco function room temperature			
b5:0	With remote control: no room temperature- dependent heating circuit pump logic function (change code only for heating circuit with mixer)	b5:1 to b5:8	Heating circuit pump logic function, see the following table:

Parameter address b5:...	With heating circuit pump logic function:	
	Heating circuit pump "OFF"	Heating circuit pump "ON"
1	$RT_{actual} > RT_{set} + 5 \text{ K}$	$RT_{actual} < RT_{set} + 4 \text{ K}$
2	$RT_{actual} > RT_{set} + 4 \text{ K}$	$RT_{actual} < RT_{set} + 3 \text{ K}$
3	$RT_{actual} > RT_{set} + 3 \text{ K}$	$RT_{actual} < RT_{set} + 2 \text{ K}$
4	$RT_{actual} > RT_{set} + 2 \text{ K}$	$RT_{actual} < RT_{set} + 1 \text{ K}$
5	$RT_{actual} > RT_{set} + 1 \text{ K}$	$RT_{actual} < RT_{set}$
6	$RT_{actual} > RT_{set}$	$RT_{actual} < RT_{set} - 1 \text{ K}$
7	$RT_{actual} > RT_{set} - 1 \text{ K}$	$RT_{actual} < RT_{set} - 2 \text{ K}$
8	$RT_{actual} > RT_{set} - 2 \text{ K}$	$RT_{actual} < RT_{set} - 3 \text{ K}$

Heating circuit 1, heating circuit 2, heating... (cont.)

Coding in the delivered condition		Possible change	
Flow temperature minimum limit			
C5:20	Electronic minimum flow temperature limit 20 °C	C5:1 to C5:127	Minimum limit adjustable from 1 to 127 °C (limited by boiler-specific parameters)
Flow temperature maximum limit			
C6:74	Electronic maximum flow temperature limit set to 74 °C	C6:10 to C6:127	Maximum limit adjustable from 10 to 127 °C (limited by boiler-specific parameters)
Heating program - changeover			
d5:0	External heating program changeover changes to "Constant operation with reduced room temperature" or "Standby mode".	d5:1	The external heating program changeover changes to "Constant operation with standard room temperature" (independent of coding address 3A, 3b and 3C)
Ext. heating program changeover to heating circuit			
d8:0	No heating program changeover via extension EA1	d8:1	Heating program changeover via input DE1 at extension EA1
		d8:2	Heating program changeover via input DE2 at extension EA1
		d8:3	Heating program changeover via input DE3 at extension EA1
Screed function			
F1:0	Screed function disabled.	F1:1 to F1:6	Screed drying function adjustable in accordance with 6 optional temperature/time profiles (see page 137)
		F1:15	Constant flow temperature 20 °C

Heating circuit 1, heating circuit 2, heating... (cont.)



Coding in the delivered condition		Possible change	
Party mode time limit			
F2:8	Time limit for party mode or external heating program changeover via key: 8 h ^{*1}	F2:0	No time limit for party mode ^{*1}
		F2:1 to F2:12	Time limit adjustable from 1 to 12 h ^{*1}
Start temperature raising			
F8:-5	Temperature limit for terminating the reduced mode -5 °C, see example on page 140. Observe the setting of coding address "A3"	F8:+10 to F8:-60	Temperature limit adjustable from +10 to -60 °C
		F8:-61	Function disabled
End temperature raising			
F9:-14	Temperature limit for raising the reduced set room temperature -14 °C, see example on page 140.	F9:+10 to F9:-60	Temperature limit for raising the set room temperature to the value selected for standard mode adjustable from +10 to -60 °C
Increase set flow temperature			
FA:20	Raising the set boiler water temperature or the set flow temperature when changing from operation with reduced room temperature to operation with standard room temperature by 20 %. See example on page 141.	FA:0 to FA:50	Temperature rise adjustable from 0 to 50 %
Duration set flow temperature increase			
Fb:30	Duration for raising the set boiler water temperature or the set flow temperature (see coding address "FA") 60 min. See example on page 141.	Fb:0 to Fb:150	Duration adjustable from 0 to 300 min; 1 step \triangleq 2 min

^{*1} Party mode ends **automatically** in the "Heating and DHW" program, when the system changes over to operation with standard room temperature.

Calling up coding level 2

Note

- In coding level 2, all codes are accessible, including the codes from coding level 1.
- Codes that have no function due to the heating system equipment level or the setting of other codes are not displayed.
- Heating systems with one heating circuit without mixer and one or two heating circuits with mixer:
The heating circuit without mixer is designated "**Heating circuit 1**" and the heating circuits with mixer as "**Heating circuit 2**" or "**Heating circuit 3**".
If the heating circuits were given individual designations, the selected designation and "**HC1**", "**HC2**" or "**HC3**" appear instead.

1. Press **OK** and  simultaneously for approx. 4 s.
2. Press **OK** and  simultaneously for approx. 4 s.
3. "**Coding level 2**"

4. Select group of required coding address:
 - "**General**"
 - "**Boiler**"
 - "**DHW**"
 - "**Solar**"
 - "**Heating circuit 1/2/3**"
 - "**All cod. or solar**"

In this group, all coding addresses (except the coding addresses from the "**Solar**" group) are displayed in ascending order.
5. Select coding address.
6. Select value according to the following tables and confirm with "**OK**".
7. **If you want to reset all codes to their delivered condition:**
Select "**Standard setting**" in "**Coding level 2**".

Note

This also resets codes from coding level 1.

General

Coding

Coding in the delivered condition		Possible change	
00:2	System version 1: One heating circuit without mixer (A1), with DHW heating	00:2 to 00:10	For system schemes, see the following table:

General (cont.)

Value address 00: ...	System version	Description
2	1	One heating circuit without mixer A1 (heating circuit 1), with DHW heating (code is adjusted automatically)
4	2	One heating circuit with mixer M2 (heating circuit 2), with DHW heating
6	3, 4	One heating circuit without mixer A1 (heating circuit 1) and one heating circuit with mixer M2 (heating circuit 2), with DHW heating (code is adjusted automatically)
8	5	One heating circuit with mixer M2 (heating circuit 2) and one heating circuit with mixer M3 (heating circuit 3), with DHW heating
10	5	One heating circuit without mixer A1 (heating circuit 1), one heating circuit with mixer M2 (heating circuit 2) and one heating circuit with mixer M3 (heating circuit 3), with DHW heating (code is adjusted automatically)

Coding in the delivered condition		Possible change	
11:≠9	No access to the coding addresses for the combustion controller parameters	11:9	Access open to the coding addresses for the combustion controller parameters
32:0	Without extension AM1	32:1	With extension AM1 (automatic recognition)
33:1	Function output A1 at extension AM1: Heating circuit pump	33:0	Function output A1: DHW circulation pump
		33:2	Function output A1: Circulation pump for cylinder heating
34:0	Function output A2 at extension AM1: DHW circulation pump	34:1	Function output A2: Heating circuit pump
		34:2	Function output A2: Circulation pump for cylinder heating
35:0	Without extension EA1	35:1	With extension EA1 (automatic recognition)
36:0	Function output 157 at extension EA1: Fault message	36:1	Function output 157 : Feed pump
		36:2	Function output 157 : DHW circulation pump



General (cont.)

Coding in the delivered condition		Possible change	
3A:0	Function input DE1 at extension EA1: without function	3A:1	Function input DE1: Heating program changeover
		3A:2	Function input DE1: External demand with set flow temperature. Function internal circulation pump: Coding address 3F
		3A:3	Function input DE1: External blocking. Function internal circulation pump: Coding address 3E
		3A:4	Function input DE1: External blocking with fault message input Function internal circulation pump: Coding address 3E
		3A:5	Function input DE1: Fault message input
		3A:6	Function input DE1: Brief operation, DHW circulation pump (pushbutton function). DHW circulation pump runtime adjustment: Coding address 3d

General (cont.)

Coding in the delivered condition		Possible change	
3b:0	Function input DE2 at extension EA1: without function	3b:1	Function input DE2: Heating program changeover
		3b:2	Function input DE2: External demand with set flow temperature. Function internal circulation pump: Coding address 3F
		3b:3	Function input DE2: External blocking. Function internal circulation pump: Coding address 3E
		3b:4	Function input DE2: External blocking with fault message input Function internal circulation pump: Coding address 3E
		3b:5	Function input DE2: Fault message input
		3b:6	Function input DE2: Brief operation, DHW circulation pump (pushbutton function). DHW circulation pump runtime adjustment: Coding address 3d



General (cont.)

Coding in the delivered condition		Possible change	
3C:0	Function input DE3 at extension EA1: without function	3C:1	Function input DE3: Heating program changeover
		3C:2	Function input DE3: External demand with set flow temperature. Function internal circulation pump: Coding address 3F
		3C:3	Function input DE3: External blocking. Function internal circulation pump: Coding address 3E
		3C:4	Function input DE3: External blocking with fault message input Function internal circulation pump: Coding address 3E
		3C:5	Function input DE3: Fault message input
		3C:6	Function input DE3: Brief operation, DHW circulation pump (pushbutton function). DHW circulation pump runtime adjustment: Coding address 3d
3d:5	DHW circulation pump runtime for brief operation: 5 min	3d:1 to 3d:60	DHW circulation pump runtime adjustable from 1 to 60 min
3E:0	Internal circulation pump stays in control mode at signal "External blocking"	3E:1	Internal circulation pump stops at signal "External blocking"
		3E:2	Internal circulation pump starts at signal "External blocking"

General (cont.)

Coding in the delivered condition		Possible change	
3F:0	Internal circulation pump stays in control mode at signal "External demand"	3F:1	Internal circulation pump stops at signal "External demand"
		3F:2	Internal circulation pump starts at signal "External demand"
51:0	System with low loss header: Internal circulation pump always starts when there is a heat demand.	51:1	System with low loss header: When there is a heat demand, the internal circulation pump will only be started when the burner is operational.
		51:2	System with heating water buffer cylinder: When there is a heat demand, the internal circulation pump will only be started when the burner is operational.
52:0	Without flow temperature sensor for low loss header	52:1	With flow temperature sensor for low loss header (automatic recognition)
54:3	Do not adjust		
6E:50	Do not adjust		
76:0	Without LON communication module (only for weather-compensated control units)	76:1	With LON communication module (automatic recognition)
77:1	LON subscriber number (only for weather-compensated control units)	77:2 to 77:99	LON subscriber number, adjustable from 1 to 99: 1 - 4 = Boiler 5 = Cascade 10 - 98 = Vitotronic 200-H 99 = Vitocom Note <i>Allocate each number only once.</i>



General (cont.)

Coding in the delivered condition		Possible change	
79:1	With LON communication module: Control unit is fault manager (only for weather-compensated control units)	79:0	Control unit is not fault manager
7b:1	With LON communication module: The control unit transmits the time (only for weather-compensated control units)	7b:0	Does not transmit time
7F:1	Detached house (only for weather-compensated control units)	7F:0	Apartment building Separate adjustment of holiday program and time program for DHW heating, as option
80:6	A fault message is displayed, providing a fault is active for at least 30 s	80:0	Immediate fault message
		80:2 to 80:199	Minimum fault duration until fault message occurs, adjustable from 10 s to 995 s; 1 step \pm 5 s
81:1	Automatic summer/winter time changeover	81:0	Manual summer/winter time changeover
		81:2	Use of the radio clock receiver (automatic recognition)
		81:3	With LON communication module: The control unit receives the time
82:0	Operation with natural gas	82:1	Operation with LPG (only adjustable if coding address 11:9 has been set)
86:0	Do not adjust		
87:0	Do not adjust		
88:0	Temperature displayed in °C (Celsius)	88:1	Temperature displayed in °F (Fahrenheit)
8A:175	Do not adjust		
8F:0	All control elements active	8F:1	All control elements locked out
		8F:2	Only standard settings can be controlled

General (cont.)

Coding in the delivered condition		Possible change	
90:128	Time constant for calculating the adjusted outside temperature 21.3 h	90:1 to 90:199	Fast (low values) or slow (high values) matching of the flow temperature, subject to the set value when the outside temperature changes; 1 step \triangleq 10 min
94:0	Without Open Therm extension	94:1	With Open Therm extension (automatic recognition)
95:0	Without Vitocom 100 communication interface	95:1	With Vitocom 100 communication interface (automatic recognition)
97:0	With LON communication module: The outside temperature of the sensor connected to the control unit is utilised internally (only for weather-compensated control units)	97:1	The control unit receives the outside temperature
		97:2	The control unit transmits the outside temperature to the Vitotronic 200-H
98:1	Viessmann system number (in conjunction with monitoring of several systems via Vitocom 300)	98:1 to 98:5	System number adjustable from 1 to 5
99:0	Never adjust		
9A:0	Never adjust		
9b:70	Set flow temperature for external demand 70 °C	9b:0 to 9b:127	Set flow temperature for external demand adjustable from 0 to 127 °C (limited by boiler-specific parameters)

General (cont.)

Coding in the delivered condition		Possible change	
9C:20	Monitoring LON subscribers. If a subscriber fails to respond, the values specified inside the control unit will be used after 20 min. Only then will a fault message be issued. (only for weather-compensated control units)	9C:0	No monitoring
		9C:5 to 9C:60	The time is adjustable from 5 to 60 min
9F:8	Differential temperature 8 K; only in conjunction with the mixer circuit (only for weather-compensated control units)	9F:0 to 9F:40	Differential temperature adjustable from 0 to 40 K

Select boiler**Coding**

Coding in the delivered condition		Possible change	
04:1	Minimum burner pause subject to the boiler load (specified by boiler coding card)	04:0	Minimum burner pause set permanently (specified by boiler coding card) Adjust for systems with low loss header.
06:...	Maximum limit of the boiler water temperature, specified in °C by the boiler coding card	06:20 to 06:127	Maximum limit of the boiler water temperature within the ranges specified by the boiler
0d:0	Do not adjust		
0E:0	Do not adjust		
13:1	Do not adjust		
14:1	Do not adjust		
15:1	Do not adjust		

Select boiler (cont.)

Coding in the delivered condition		Possible change	
21:0	No service interval (hours run) selected	21:1 to 21:100	The number of hours run before the burner should be serviced is adjustable from 100 to 10 000 h One adjusting step $\hat{=}$ 100 h
23:0	No time interval for burner service	23:1 to 23:24	Interval adjustable from 1 to 24 months
24:0	No "Service" display	24:1	"Service" display (the address is automatically set and must be manually reset after a service has been carried out)
28:0	No burner interval ignition	28:1 to 28:24	Time interval adjustable from 1 h to 24 h. The burner is force-started once every 30 s (only when operating with LPG).
2E:0	Never adjust		
2F:0	Venting program/fill program disabled	2F:1	Venting program enabled
		2F:2	Fill program enabled
30:0	Never adjust		
38:0	Status burner control unit: Operational (no fault)	38:≠0	Status burner control unit: Fault

DHW

Coding

Coding in the delivered condition		Possible change	
56:0	Set DHW temperature adjustable from 10 to 60 °C	56:1	Set DHW temperature adjustable from 10 to above 60 °C Note <i>Maximum value subject to boiler coding card. Observe the max. permissible DHW temperature.</i>
58:0	Without auxiliary function for DHW heating	58:10 to 58:60	Input of a second set DHW temperature, adjustable from 10 to 60 °C (observe coding addresses "56" and "63")
5E:0	Circulation pump for cylinder heating stays in control mode at signal "External blocking"	5E:1	Circulation pump for cylinder heating stops at signal "External blocking"
		5E:2	Circulation pump for cylinder heating starts at signal "External blocking"
5F:0	Circulation pump for cylinder heating stays in control mode at signal "External demand"	5F:1	Circulation pump for cylinder heating stops at signal "External demand"
		5F:2	Circulation pump for cylinder heating starts at signal "External demand"
65:...	Information regarding the type of diverter valve (not adjustable): 1: Viessmann diverter valve 2: Wilo diverter valve 3: Grundfos diverter valve		

DHW (cont.)

Coding in the delivered condition		Possible change	
67:40	For solar DHW heating: set DHW temperature 40 °C. DHW reheating is suppressed above the selected set temperature (DHW heating blocked by the boiler).	67:0 to 67:95	Set DHW temperature adjustable from 0 to 95 °C (limited by boiler-specific parameters)
6C:100	Set speed; internal circulation pump with DHW heating 100 %	6C:0 to 6C:100	Set speed adjustable from 0 to 100 %
6F:...	Maximum output for DHW heating in %, specified by the boiler coding card	6F:0 to 6F:100	Max. output for DHW heating adjustable from min. output to 100 %
71:0	DHW circulation pump: "ON" according to time program	71:1	"OFF" during DHW heating to the first set value
		71:2	"ON" during DHW heating to the first set value
72:0	DHW circulation pump: "ON" according to time program	72:1	"OFF" during DHW heating to the second set value
		72:2	"ON" during DHW heating to the second set value
73:0	DHW circulation pump: "ON" according to time program	73:1 to 73:6	"ON" from once per hour for 5 min up to 6 times per hour for 5 min during the time program
		73:7	Constantly "ON"

Solar

Coding

Coding in the delivered condition		Possible change	
00:8	The solar circuit pump starts when the collector temperature exceeds the actual cylinder temperature by 8 K.	00:2 to 00:30	The differential between the actual cylinder temperature and the start point for the solar circuit pump can be adjusted from 2 to 30 K.
01:4	The solar circuit pump stops when the differential between the collector temperature and the actual cylinder temperature is less than 4 K.	01:1 to 01:29	The differential between the actual cylinder temperature and the stop point for the solar circuit pump can be adjusted from 1 to 29 K.
02:1	Solar circuit pump (multi-stage) is speed-controlled with wave pack control	02:0	Solar circuit pump (multi-stage) is not speed-controlled
		02:2	Do not adjust
03:10	The temperature differential between the collector temperature and actual cylinder temperature is regulated to 10 K.	03:5 to 03:20	The differential temperature control between collector temperature and actual cylinder temperature can be adjusted from 5 to 20 K
04:4	Controller amplification of the speed control 4 %/K.	04:1 to 04:10	Controller amplification adjustable from 1 to 10 %/K
05:10	Minimum speed of the solar circuit pump 10 % of the maximum speed	05:2 to 05:100	Minimum speed of the solar circuit pump is adjustable from 2 to 100 %
06:75	Maximum speed of the solar circuit pump 75 % of the maximum possible speed	06:2 to 06:100	Maximum speed of the solar circuit pump is adjustable from 2 to 100 %

Solar (cont.)

Coding in the delivered condition		Possible change	
07:0	Interval function of the solar circuit pump switched off	07:1	Interval function of the solar circuit pump switched on. To capture the collector temperature more accurately, the solar circuit pump starts for short cycles.
08:60	The solar circuit pump will stop when the actual cylinder temperature reaches 60 °C (maximum cylinder temperature).	08:10 to 08:90	The maximum cylinder temperature can be adjusted from 10 to 90 °C
09:130	The solar circuit pump will be switched off when the collector temperature reaches 130 °C.	09:20 to 09:200	The temperature can be adjusted from 20 to 200 °C
0A:5	To protect the system components and heat transfer medium, the speed of the solar circuit pump is reduced when the differential between the actual cylinder temperature and set cylinder temperature is less than 5 K.	0A:0 to 0A:40	The differential between the set cylinder temperature and the start point for reducing the stagnation time can be adjusted from 0 to 40 K.
0b:0	Collector frost protection function switched off	0b:1	Collector frost protection function switched on (not required with Viessmann heat transfer medium).
0C:1	Delta T monitoring switched on. No flow rate captured in the collector circuit, or flow rate too low.	0C:0	Delta T monitoring switched off.
0d:1	Night circulation monitoring switched on. Unintentional flow rate is captured in the collector circuit (e.g. at night).	0d:0	Night circulation monitoring switched OFF.



Solar (cont.)

Coding in the delivered condition		Possible change	
0E:1	Calculation of solar yield with Viessmann heat transfer medium	0E:2	Calculation of solar yield with heat transfer medium water (do not adjust)
		0E:0	Calculation of solar yield switched off
0F:70	The flow rate in the collector circuit at the maximum pump speed is set to 7 l/min.	0F:1 to 0F:255	Flow rate in the collector circuit adjustable from 0.1 to 25,5 l/min
10:0	Target temperature control switched off (see coding address 11)	10:1	Target temperature control switched on
11:50	Set cylinder temperature for solar 50 °C. <ul style="list-style-type: none"> ■ Target temperature control switched on (code 10:1): Temperature at which the solar heated water in the DHW cylinder is to be stratified. 	11:10 to 11:90	The set cylinder temperature for solar can be adjusted from 10 to 90 °C
12:20	Minimum collector temperature 20 °C. The solar circuit pump is not started until the minimum collector temperature set at the collector temperature sensor is exceeded.	12:0	Minimum collector temperature function switched off
		12:1 to 12:90	The minimum collector temperature can be adjusted from 1 to 90 °C

Heating circuit 1, heating circuit 2, heating circuit 3

Coding

Coding in the delivered condition		Possible change	
A0:0	Without remote control	A0:1	With Vitotrol 200A (automatic recognition)
		A0:2	With Vitotrol 300A or Vitohome 300 (automatic recognition)
A1:0	All possible settings at the remote control can be accessed	A1:1	Only party mode can be set at the remote control (only for Vitotrol 200A)
A3:2	Outside temperature below 1 °C: Heating circuit pump "ON" Outside temperature above 3 °C: Heating circuit pump "OFF"	A3:-9 to A3:15	Heating circuit pump "ON/OFF" (see the following table)



Please note

If a value below 1 °C is selected, there is a risk that pipes outside the thermal envelope of the house could freeze up.
The standby mode, in particular, should be taken into consideration, e.g. during holidays.

Parameter Address A3:...	Heating circuit pump	
	"ON"	"OFF"
-9	-10 °C	-8 °C
-8	-9 °C	-7 °C
-7	-8 °C	-6 °C
-6	-7 °C	-5 °C
-5	-6 °C	-4 °C
-4	-5 °C	-3 °C
-3	-4 °C	-2 °C
-2	-3 °C	-1 °C
-1	-2 °C	0 °C
0	-1 °C	1 °C
1	0 °C	2 °C
2	1 °C	3 °C
to	to	to
15	14 °C	16 °C

Heating circuit 1, heating circuit 2, heating... (cont.)

Coding in the delivered condition		Possible change	
A4:0	With frost protection	A4:1	No frost protection; this setting is only possible if code "A3:-9" has been selected. Note See "Please note" regarding coding address "A3"
A5:5	With heating circuit pump logic function (economy circuit): Heating circuit pump "OFF" when the outside temperature (AT) is 1 K higher than the set room temperature (RT_{set}) $AT > RT_{set} + 1 K$	A5:0	Without heating circuit pump logic function
		A5:1 to A5:15	With heating circuit pump logic function: Heating circuit pump "OFF"; see the following table

Parameter address A5:...	With heating circuit pump logic function: Heating circuit pump "OFF"
1	$AT > RT_{set} + 5 K$
2	$AT > RT_{set} + 4 K$
3	$AT > RT_{set} + 3 K$
4	$AT > RT_{set} + 2 K$
5	$AT > RT_{set} + 1 K$
6	$AT > RT_{set}$
7	$AT > RT_{set} - 1 K$
to 15	$AT > RT_{set} - 9 K$

Heating circuit 1, heating circuit 2, heating... (cont.)

Coding in the delivered condition		Possible change	
A6:36	Extended economy mode disabled	A6:5 to A6:35	Extended economy control enabled, i.e. the burner and heating circuit pump will stop and the mixer close at a variable value, adjustable between 5 and 35 °C plus 1 °C. The base value is the adjusted outside temperature. This value is based on the actual outside temperature and a time constant that takes the cooling down of an average building into consideration.
A7:0	Without mixer economy function (only for heating circuits with mixer)	A7:1	With mixer economy function (extended heating circuit pump logic): Heating circuit pump also "OFF": <ul style="list-style-type: none"> ■ If a mixer has been attempting to close for longer than 20 min. Heating circuit pump "ON": <ul style="list-style-type: none"> ■ If the mixer changes to control function ■ If there is a risk of frost
A8:1	Heating circuit with mixer creates a demand for the internal circulation pump	A8:0	Heating circuit with mixer creates no demand for the internal circulation pump
A9:7	With pump idle time: Heating circuit pump "OFF" in case of set value modification by changing the operating mode or changing the set room temperature	A9:0 A9:1 to A9:15	Without pump idle time With pump idle time; adjustable from 1 to 15



Heating circuit 1, heating circuit 2, heating... (cont.)

Coding in the delivered condition		Possible change	
b0:0	With remote control: Heating mode/reduced mode: weather-compensated (change code only for the heating circuit with mixer)	b0:1	Heating mode: weather-compensated Reduced mode: with room temperature hook-up
		b0:2	Heating mode: with room temperature hook-up Reduced mode: weather-compensated
		b0:3	Heating mode/reduced mode: with room temperature hook-up
b2:8	With remote control and for the heating circuit, operation with room temperature hook-up must be programmed: Room influence factor 8 (change code only for heating circuit with mixer)	b2:0	Without room influence
		b2:1 to b2:64	Room influence factor adjustable from 1 to 64
b5:0	With remote control: no room temperature-dependent heating circuit pump logic function (change code only for heating circuit with mixer)	b5:1 to b5:8	Heating circuit pump logic function, see the following table:

Parameter address b5:...	With heating circuit pump logic function:	
	Heating circuit pump "OFF"	Heating circuit pump "ON"
1	$RT_{actual} > RT_{set} + 5 \text{ K}$	$RT_{actual} < RT_{set} + 4 \text{ K}$
2	$RT_{actual} > RT_{set} + 4 \text{ K}$	$RT_{actual} < RT_{set} + 3 \text{ K}$
3	$RT_{actual} > RT_{set} + 3 \text{ K}$	$RT_{actual} < RT_{set} + 2 \text{ K}$
4	$RT_{actual} > RT_{set} + 2 \text{ K}$	$RT_{actual} < RT_{set} + 1 \text{ K}$
5	$RT_{actual} > RT_{set} + 1 \text{ K}$	$RT_{actual} < RT_{set}$
6	$RT_{actual} > RT_{set}$	$RT_{actual} < RT_{set} - 1 \text{ K}$
7	$RT_{actual} > RT_{set} - 1 \text{ K}$	$RT_{actual} < RT_{set} - 2 \text{ K}$
8	$RT_{actual} > RT_{set} - 2 \text{ K}$	$RT_{actual} < RT_{set} - 3 \text{ K}$

Heating circuit 1, heating circuit 2, heating... (cont.)

Coding in the delivered condition		Possible change	
C5:20	Electronic minimum flow temperature limit 20 °C	C5:1 to C5:127	Minimum limit adjustable from 1 to 127 °C (limited by boiler-specific parameters)
C6:74	Electronic maximum flow temperature limit set to 74 °C	C6:10 to C6:127	Maximum limit adjustable from 10 to 127 °C (limited by boiler-specific parameters)
d3:14	Heating curve slope = 1.4	d3:2 to d3:35	Heating curve slope adjustable from 0.2 to 3.5 (see page 58)
d4:0	Heating curve level = 0	d4:-13 to d4:40	Heating curve level adjustable from -13 to 40 (see page 58)
d5:0	External heating program changeover changes to "Constant operation with reduced room temperature" or "Standby mode"	d5:1	The external heating program changeover changes to "Constant operation with standard room temperature" (independent of coding address 3A, 3b and 3C)
d6:0	Heating circuit pump stays in control mode at signal "External blocking"	d6:1	Heating circuit pump stops at signal "External blocking" (subject to coding addresses 3A, 3b and 3C)
		d6:2	Heating circuit pump starts at signal "External blocking" (subject to coding addresses 3A, 3b and 3C)
d7:0	Heating circuit pump stays in control mode at signal "External demand"	d7:1	Heating circuit pump stops at signal "External demand" (subject to coding addresses 3A, 3b and 3C)
		d7:2	Heating circuit pump starts at signal "External demand" (subject to coding addresses 3A, 3b and 3C)



Heating circuit 1, heating circuit 2, heating... (cont.)

Coding in the delivered condition		Possible change	
d8:0	No heating program changeover via extension EA1	d8:1	Heating program changeover via input DE1 at extension EA1
		d8:2	Heating program changeover via input DE2 at extension EA1
		d8:3	Heating program changeover via input DE3 at extension EA1
E1:1	Do not adjust		
E2:50	With remote control: No display correction of the actual room temperature	E2:0 to E2:49	Display correction -5 K to Display correction -0.1 K
		E2:51 to E2:99	Display correction +0.1 K to Display correction +4.9 K
E5:0	Without external, variable speed heating circuit pump		
F1:0	Screed function disabled	F1:1 to F1:6	Screed drying function adjustable in accordance with 6 optional temperature/time profiles (see page 137)
		F1:15	Constant flow temperature 20 °C
F2:8	Time limit for party mode or external heating program changeover via key: 8 h ^{*1}	F2:0	No time limit for party mode ^{*1}
		F2:1 to F2:12	Time limit adjustable from 1 to 12 h ^{*1}
F8:-5	Temperature limit for terminating the reduced mode -5 °C, see example on page 140. Observe the setting of coding address "A3"	F8:+10 to F8:-60	Temperature limit adjustable from +10 to -60 °C
		F8:-61	Function disabled

^{*1} Party mode ends **automatically** in the "Heating and DHW" program, when the system changes over to operation with standard room temperature.

Heating circuit 1, heating circuit 2, heating... (cont.)

Coding in the delivered condition		Possible change	
F9:-14	Temperature limit for raising the reduced set room temperature -14 °C, see example on page 140.	F9:+10 to F9:-60	Temperature limit for raising the set room temperature to the value selected for standard mode adjustable from +10 to -60 °C
FA:20	Raising the set boiler water temperature or the set flow temperature when changing from operation with reduced room temperature to operation with standard room temperature by 20 %. See example on page 141	FA:0 to FA:50	Temperature rise adjustable from 0 to 50 %
Fb:30	Duration for raising the set boiler water temperature or the set flow temperature (see coding address "FA") 60 min. See example on page 141.	Fb:0 to Fb:150	Duration adjustable from 0 to 300 min; 1 step \triangleq 2 min

Calling up the service menu

Press **OK** and **≡** simultaneously for approx. 4 s.

Service menu overview

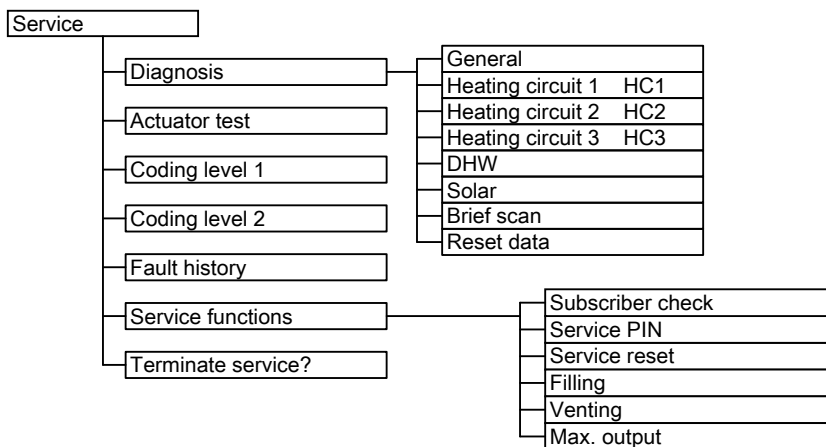

Diagnosis

Scanning operating data

Operating data can be scanned in six areas. See **"Diagnosis"** in the service menu overview.

Operating data on heating circuits with mixers and solar can only be scanned if the components are installed in the system.

For further information on operating data, see chapter "Brief scan".

Note

"- - -" appears on the display if a sensor that has been scanned is faulty.

Calling up operating data

1. Press **OK** and **≡** simultaneously for approx. 4 s.

2. "Diagnosis"

3. Select required group, e.g. **"General"**.

Diagnosis (cont.)

Resetting operating data

Saved operating data (e.g. hours run) can be reset to 0.
The value "Adjusted outside temp" is reset to the actual value.

1. Press **OK** and  simultaneously for approx. 4 s.
2. **"Diagnosis"**
3. **"Reset data"**
4. Select required value (e.g. **"Burner starts"**) or **"All details"**.

Brief scan

In the brief scan, you can scan temperatures, software versions and connected components, for example.

1. Press **OK** and  simultaneously for approx. 4 s.
2. **"Diagnosis"**
3. **"Brief scan"**.
4. Press **OK**.
The display shows 9 lines with 6 fields each.

Diagnose Kurzabfrage					
1:	1	F	0	A	1 2
2:	0	0	0	0	0 0
3:	0	0	0	0	0 0
4:	0	0	0	0	0 0

Wählen mit 

For an explanation of the relevant values in the individual lines and fields, see the following table:

Line (brief scan)	Field					
	1	2	3	4	5	6
1:	Software version Control unit		Equipment version		Burner control unit version	
2:	System scheme 01 to 10		Number of KM BUS subscribers	Maximum demand temperature		



Diagnosis and service scans

Diagnosis (cont.)

Line (brief scan)	Field					
	1	2	3	4	5	6
3:		Software version Programming unit	Software version Mixer extension 0: No mixer extension	Software version Solar control module SM1	Software version LON module	0
4:	Software version Burner control unit		Type Burner control unit		Appliance type	
5:	0	0		0	0	0
6:	Number of LON subscribers		Check digit	Max. output Details in %		
7:	Heating circuit A1 (without mixer) Remote control 0: w/o 1: Vitotrol 200A 2: Vitotrol 300A or Vithome		Heating circuit M2 (with mixer) Remote control 0: w/o 1: Vitotrol 200A 2: Vitotrol 300A or Vithome		Heating circuit M3 (with mixer) Remote control 0: w/o 1: Vitotrol 200A 2: Vitotrol 300A or Vithome	

Diagnosis (cont.)

Line (brief scan)	Field					
	1	2	3	4	5	6
8:	Internal circulation pump		Heating circuit pump, heating circuit M2		Heating circuit pump, heating circuit M3	
	Variable speed pump 0: without 1: Wilo 2: Grundfos	Software version variable speed pump 0: no variable speed pump	Variable speed pump 0: without 1: Wilo 2: Grundfos	Software version Variable speed pump 0: no variable speed pump	Variable speed pump 0: without 1: Wilo 2: Grundfos	Software version Variable speed pump 0: no variable speed pump
9:	Internal details for calibration				Software version Extension AM1	Software version Extension EA1

Checking outputs (actuator test)

1. Press **OK** and  simultaneously for approx. 4 s.
2. **"Actuator test"**

The following relay outputs can be controlled subject to system design:

Display	Explanation
Base load start	Burner operates at minimum output; internal pump starts
Full load start	Burner operates at maximum output; internal pump starts
Outp. internal start	Internal output  (internal pump) enabled
Start valve heating	Diverter valve set to heating mode
Start valve centre	Diverter valve in central position (filling/draining)
Start valve cylinder	Diverter valve set to DHW mode
Htg circ pump HC2 start	Heating circuit pump output enabled (extension to heating circuit with mixer)
Mixer HC2 open	"Mixer open" output enabled (extension to heating circuit with mixer)
Mixer HC2 close	"Mixer close" output enabled (extension to heating circuit with mixer)

5412 755 GB

Service



Checking outputs (actuator test) (cont.)

Display	Explanation
Htg circ pump HC3 start	Heating circuit pump output enabled (extension to heating circuit with mixer)
Mixer HC3 open	"Mixer open" output enabled (extension to heating circuit with mixer)
Mixer HC3 close	"Mixer close" output enabled (extension to heating circuit with mixer)
Outp. int. exten. H1 start	Output at internal extension enabled
AM1 output 1 start	Output A1 at extension AM1 enabled
AM1 output 2 start	Output A2 at extension AM1 enabled
EA1 output 1 start	Contacts P - S at plug 157 for extension EA1 closed
Solar circuit pump start	Solar circuit pump 24 output at solar control module SM1 enabled
Solar circ pmp min start	Solar circuit pump output at solar control module SM1 switched to minimum speed
Solar circ pmp max start	Solar circuit pump output at solar control module SM1 switched to maximum speed

Fault display

If there is a fault, the red fault indicator (A) flashes. "△" flashes on the display and "Fault" is shown.

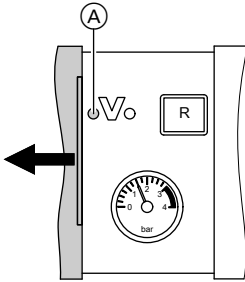

The fault code is displayed with **OK**. For an explanation of the fault code, see the following pages.

For some faults, the type of fault is also displayed in plain text.

Acknowledging a fault

Follow the instructions on the display.

Note

The fault message is shown in the standard display of the short menu.

If a fault messaging facility is connected, it will be switched off.

If an acknowledged fault is not remedied, the fault message will be re-displayed the following day and the fault message facility restarted.

Calling up acknowledged faults

Select "**Fault**" in the standard menu. The current faults will be displayed in a list.

Calling up fault codes from the fault memory (fault history)

The 10 most recent faults (including resolved ones) are saved and can be scanned.

Faults are sorted by date.

1. Press **OK** and  simultaneously for approx. 4 s.
2. "**Fault history**"
3. "**Display?**"

Fault codes

Displayed fault code	System characteristics	Cause	Measures
10	Regulates as if the outside temperature was 0 °C	Short circuit, outside temperature sensor	Check the outside temperature sensor (see page 116).
18	Regulates as if the outside temperature was 0 °C	Lead break, outside temperature sensor	Check the outside temperature sensor (see page 116).
20	Regulates without flow temperature sensor (low loss header)	Short circuit, system flow temperature sensor	Check the low loss header sensor (see page 117)
28	Regulates without flow temperature sensor (low loss header)	Lead break, system flow temperature sensor	Check the low loss header sensor (see page 117)
30	Burner blocked	Short circuit, boiler water temperature sensor	Check the boiler water temperature sensor (see page 117)
38	Burner blocked	Lead break, boiler water temperature sensor	Check the boiler water temperature sensor (see page 117)
40	Mixer closes	Short circuit, flow temperature sensor, heating circuit 2 (with mixer)	Check flow temperature sensor
44	Mixer closes	Short circuit, flow temperature sensor, heating circuit 3 (with mixer)	Check flow temperature sensor
48	Mixer closes	Lead break, flow temperature sensor, heating circuit 2 (with mixer)	Check flow temperature sensor
4C	Mixer closes	Lead break, flow temperature sensor, heating circuit 3 (with mixer)	Check flow temperature sensor
50	No DHW heating	Short circuit, cylinder temperature sensor	Check sensors (see page 117)

Fault codes (cont.)

Displayed fault code	System characteristics	Cause	Measures
51	No DHW heating	Short circuit, outlet temperature sensor	Check sensors (see page 117)
58	No DHW heating	Lead break, cylinder temperature sensor	Check sensors (see page 117)
59	No DHW heating	Lead break, outlet temperature sensor	Check sensors (see page 117)
92	No DHW heating	Short circuit, collector temperature sensor (connection to the solar control module)	Check sensor 6 to the solar control module.
94	No solar DHW heating	Short circuit, cylinder temperature sensor (connection to the solar control module)	Check sensor 5 to the solar control module.
9A	No solar DHW heating	Lead break, collector temperature sensor (connection to the solar control module)	Check sensor 6 to the solar control module.
9C	No solar DHW heating	Lead break, cylinder temperature sensor (connection to the solar control module)	Check sensor 5 to the solar control module.
9E	Control mode	No flow rate in the collector circuit or flow rate too low, or temperature limiter has responded	Check solar circuit pump and solar circuit. Acknowledge fault message.
9F	Control mode	Solar control module fault	Replace solar control module
A2	Emergency mode in case of insufficient system pressure	System pressure too low	Top up with water



Fault codes (cont.)

Displayed fault code	System characteristics	Cause	Measures
A4	Control mode	Max. system pressure exceeded	Check system pressure. Check the function and sizing of the diaphragm expansion vessel. Vent the heating system. Coding address "0E" (group boiler/1) is set to "1" to document the fault. After the fault has been removed, reset manually to "0".
A7	Control mode as per delivered condition	Programming unit faulty	Replace programming unit
A8	Burner blocked. The venting program is started automatically (see page 66)	Air lock in the internal circulation pump or minimum flow rate not achieved	Vent the system if the fault message continues to be displayed
A9	The burner operates at its lower output if a heating circuit with mixer is connected. The burner is blocked if only one heating circuit without mixer is connected.	Internal circulation pump blocked	Check the circulation pump
b0	Burner blocked	Short circuit, flue gas temperature sensor	Check the flue gas temperature sensor
b1	Control mode as per delivered condition	Communication error, programming unit	Check connections and replace the programming unit if required
b4	Regulates as if the outside temperature was 0 °C	Internal fault	Replace the control unit
b5	Control mode as per delivered condition	Internal fault	Replace the control unit
b7	Burner blocked	Boiler coding card faulty	Plug in boiler coding card or replace, if faulty

Fault codes (cont.)

Displayed fault code	System characteristics	Cause	Measures
b8	Burner blocked	Lead break, flue gas temperature sensor	Check the flue gas temperature sensor
bA	Mixer regulates to 20 °C flow temperature.	Communication error, extension kit for heating circuit 2 (with mixer)	Check the extension kit connections and coding
bb	Mixer regulates to 20 °C flow temperature.	Communication error, extension kit for heating circuit 3 (with mixer)	Check the extension kit connections and coding
bC	Control mode without remote control	Communication error, remote control Vitotrol heating circuit 1 (without mixer)	Check connections, lead, coding address "A0" and remote control settings (see page 143).
bd	Control mode without remote control	Communication error, remote control Vitotrol heating circuit 2 (with mixer)	Check connections, lead, coding address "A0" and remote control settings (see page 143).
bE	Control mode without remote control	Communication error, remote control Vitotrol heating circuit 3 (with mixer)	Check connections, lead, coding address "A0" and remote control settings (see page 143).
bF	Control mode	Incorrect LON communication module	Replace the LON communication module
C1	Control mode	Communication error extension EA1	Check electrical connections
C2	Control mode	Solar control module communication fault	Check solar control module
C3	Control mode	Extension AM1 communication error	Check electrical connections

Fault codes (cont.)

Displayed fault code	System characteristics	Cause	Measures
C4	Control mode	Communication error, Open Therm extension	Check Open Therm extension
Cd	Control mode	Communication error, Vitocom 100 (KM BUS)	Check connections, Vitocom 100 and coding address "95"
CF	Control mode	Communication error, LON communication module	Replace the LON communication module
d6	Control mode	Input DE1 reports a fault at extension EA1	Remove fault at the appliance concerned
d7	Control mode	Input DE2 at extension EA1 reports a fault	Remove fault at the appliance concerned
d8	Control mode	Input DE3 at extension EA1 reports a fault	Remove fault at the appliance concerned
dA	Control mode without room influence	Short circuit, room temperature sensor, heating circuit 1 (without mixer)	Check room temperature sensor, heating circuit 1
db	Control mode without room influence	Short circuit, room temperature sensor, heating circuit 2 (with mixer)	Check room temperature sensor, heating circuit 2
dC	Control mode without room influence	Short circuit, room temperature sensor, heating circuit 3 (with mixer)	Check room temperature sensor, heating circuit 3
dd	Control mode without room influence	Lead break, room temperature sensor, heating circuit 1 (without mixer)	Check room temperature sensor, heating circuit 1 and remote control DIP switch settings (see page 143)
dE	Control mode without room influence	Lead break, room temperature sensor, heating circuit 2 (with mixer)	Check room temperature sensor, heating circuit 2 and remote control DIP switch settings (see page 143)

Fault codes (cont.)

Displayed fault code	System characteristics	Cause	Measures
dF	Control mode without room influence	Lead break, room temperature sensor, heating circuit 3 (with mixer)	Check room temperature sensor for heating circuit 3 and remote control settings (see page 143)
E0	Control mode	Fault external LON subscriber	Check connections and LON subscribers
E1	Burner in a fault state	Ionisation current too high during calibration	Check gap between ionisation electrode and burner gauze assembly (see page 40). In open flue mode, prevent very dusty conditions for the combustion air. Press reset button R .
E3	Burner in a fault state	Heat transfer too low during calibration. Temperature limiter caused shut-down.	Ensure adequate heat transfer. Press reset button R .
E4	Burner blocked	Fault, supply voltage 24 V	Replace the control unit.
E5	Burner blocked	Fault, flame amplifier	Replace the control unit.
E6	Burner blocked	System pressure too low	Top up with water.
E7	Burner in a fault state	Ionisation current too low during calibration	Check ionisation electrode: <ul style="list-style-type: none"> ■ Distance to burner gauze assembly (see page 40) ■ Contamination of electrode ■ Connecting lead and plug-in connections Check flue system; remedy flue gas recirculation if required. Press reset button R .

5412 755 GB

Service



Fault codes (cont.)

Displayed fault code	System characteristics	Cause	Measures
E8	Burner in a fault state	The ionisation current lies outside the permissible range	<p>Check gas supply (gas pressure and gas flow limiter), gas train and connecting lead. Check allocation of gas type (see page 32).</p> <p>Check ionisation electrode:</p> <ul style="list-style-type: none"> ■ Distance to burner gauze assembly (see page 40) ■ Contamination of electrode <p>Press reset button R.</p>
EA	Burner in a fault state	Ionisation current outside the permissible range during calibration (deviation from previous level too great)	<p>Check flue system; remedy flue gas recirculation if required.</p> <p>In open flue mode, prevent very dusty conditions for the combustion air. Press reset button R. Following several unsuccessful reset attempts, replace boiler coding card and press reset button R.</p>
Eb	Burner in a fault state	Repeated flame loss during calibration	<p>Check gap between ionisation electrode and burner gauze assembly (see page 40). Check allocation of gas type (see page 32). Check flue system; remedy flue gas recirculation if required. Press reset button R.</p>

Fault codes (cont.)

Displayed fault code	System characteristics	Cause	Measures
EC	Burner in a fault state	Parameter fault during calibration	Press reset button R or Replace boiler coding card and press reset button R .
Ed	Burner in a fault state	Internal fault	Replace the control unit.
EE	Burner in a fault state	Flame signal is not present or too weak at burner start	Check gas supply (gas pressure and gas flow limiter); check gas train. Check the ionisation electrode and connecting cable. Checking ignition: <ul style="list-style-type: none"> ■ Connecting leads to ignition module and ignition electrode ■ Distance to ignition electrode and contamination (see page 40). Check condensate drain. Press reset button R .
EF	Burner in a fault state	The flame is lost immediately after it has built (during the safety time).	Check gas supply (gas pressure and gas flow limiter). Check flue gas/ventilation air system for flue gas recirculation. Check ionisation electrode (replace if required): <ul style="list-style-type: none"> ■ Distance to burner gauze assembly (see page 40) ■ Contamination of electrode Press reset button R .

5412 755 GB

Service



Fault codes (cont.)

Displayed fault code	System characteristics	Cause	Measures
F0	Burner blocked	Internal fault	Replace the control unit.
F1	Burner in a fault state	Flue gas temperature limiter has responded.	Check the heating system fill level. Vent the system. Press reset button R after the flue system has cooled down.
F2	Burner in a fault state	The temperature limiter has responded.	Check the heating system fill level. Check the circulation pump. Vent the system. Check the temperature limiter and connecting cables. Press reset button R .
F3	Burner in a fault state	Flame signal is already present at burner start.	Check the ionisation electrode and connecting cable. Press reset button R .
F7	Burner blocked	Short circuit or lead break, water pressure sensor	Check the water pressure sensor and the connecting cable.
F8	Burner in a fault state	The fuel valve closes too late.	Check the gas train. Check both control paths. Press reset button R .
F9	Burner in a fault state	Fan speed too low during burner start	Check the fan, the fan connecting cables and power supply; check the fan control. Press reset button R .
FA	Burner in a fault state	Fan not at standstill	Check the fan, fan connecting cables and fan control. Press reset button R .
FC	Burner in a fault state	Gas train faulty or faulty modulation valve control or flue gas path blocked	Check the gas train. Check the flue gas system. Press reset button R .

Fault codes (cont.)

Displayed fault code	System characteristics	Cause	Measures
Fd	Burner in a fault state	Fault, burner control unit	Check ignition electrodes and connecting cables. Check whether a strong interference (EMC) field exists near the appliance. Press reset button R . Replace control unit if the fault persists.
FE	Burner blocked or in a fault state	Boiler coding card or main PCB faulty	Press reset button R . Replace boiler coding card or control unit if the fault persists.
FF	Burner blocked or in a fault state	Internal fault or reset button R blocked	Start the appliance again. Replace the control unit if the appliance will not restart.

Repairs

Putting control unit in maintenance position

If required for commissioning and servicing, the control unit can be put in a different position.

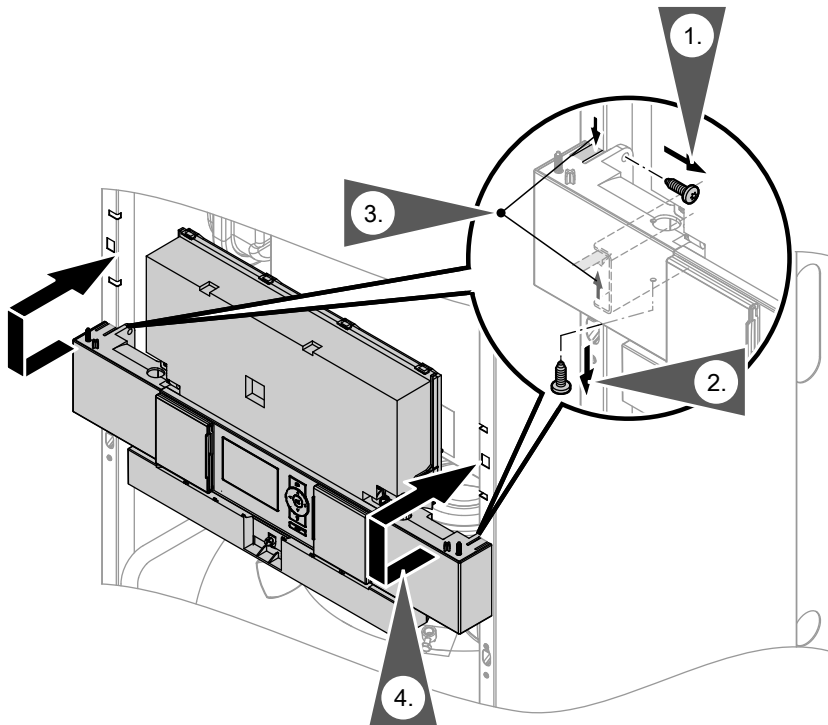

Repairs (cont.)

Draining the boiler on the heating water side

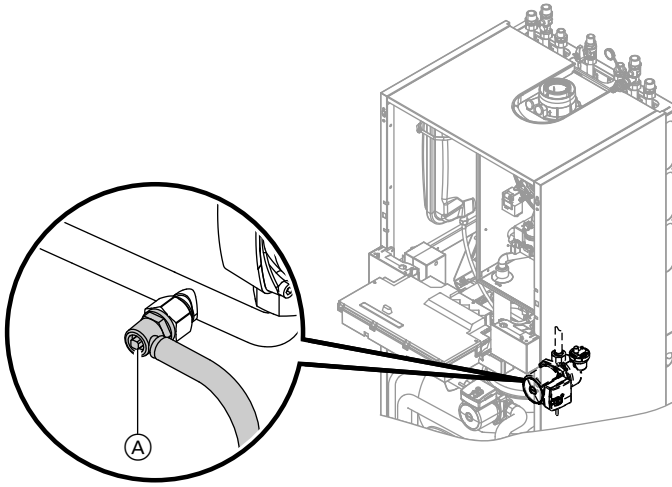

1. Close the shut-off valves on the heating water side.
2. Route hose at drain valve (A) into a suitable container or drain outlet.
3. Open drain valve (A) and drain the boiler as much as required.

Repairs (cont.)

Checking the outside temperature sensor

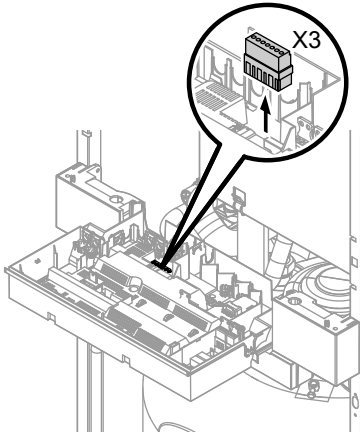

1. Pull plug "X3" from the control unit.
2. Test the resistance of the outside temperature sensor across terminals "X3.1" and "X3.2" on the disconnected plug and compare it with the curve.
3. Where actual values deviate severely from the curve values, disconnect the wires at the sensor and repeat test on the sensor itself.
4. Subject to result, replace the lead or the outside temperature sensor.

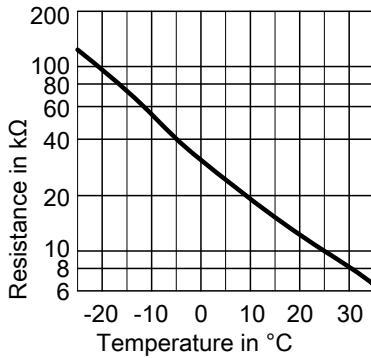

Repairs (cont.)

Checking the boiler water temperature sensor, cylinder temperature sensor or flow temperature sensor of the low loss header

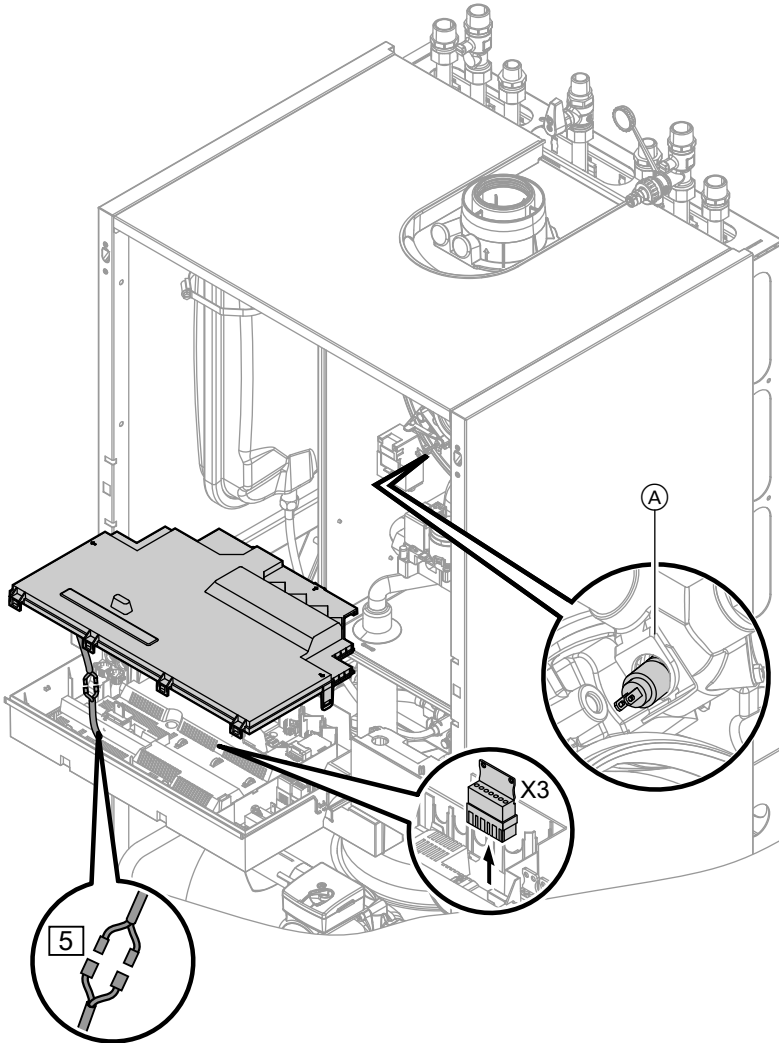

Repairs (cont.)

1. ■ **Boiler water temperature sensor**
Pull the leads from boiler water temperature sensor (A) and check the resistance.
■ **Cylinder temperature sensor**
Pull plug [5] from the cable harness at the control unit and check the resistance.
■ **Flow temperature sensor**
Pull plug "X3" from the control unit and check the resistance across terminals "X3.4" and "X3.5".
2. Check the sensor resistance and compare the actual values with the curve.
3. Replace the sensor in case of severe deviation.

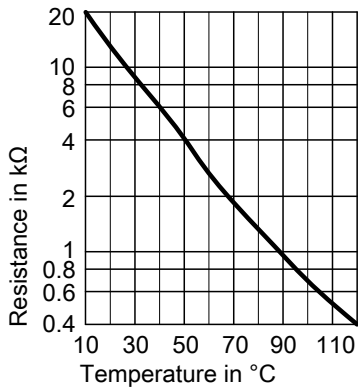

Danger

The boiler water temperature sensor is immersed in the heating water (risk of scalding).
Drain the boiler on the heating water side before replacing the sensor.

Checking collector temperature sensor or cylinder temperature sensor on the solar control module

The solar control module is attached to the l.h. side of the air box.

Repairs (cont.)

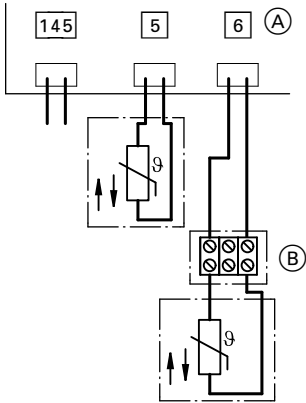

1. ■ **Cylinder temperature sensor**
Remove plug 5 from solar control module (A) and measure the resistance.
- **Collector temperature sensor**
Disconnect lead from terminal box (B) and measure its resistance.

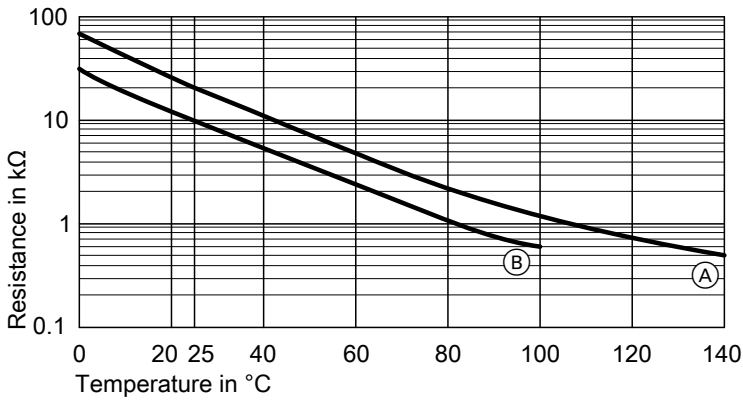

- (A) Collector temperature sensor
- (B) Cylinder temperature sensor

2. Compare the sensor resistance with the curve.
3. Replace the sensor in case of severe deviation.

Repairs (cont.)

Checking the outlet temperature sensor

1. Pull the leads from outlet temperature sensor (A).

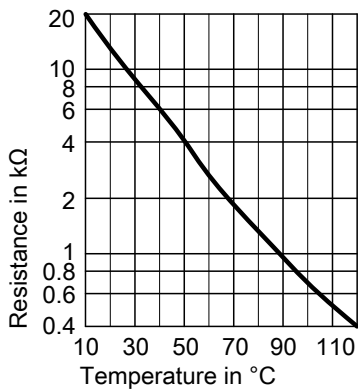
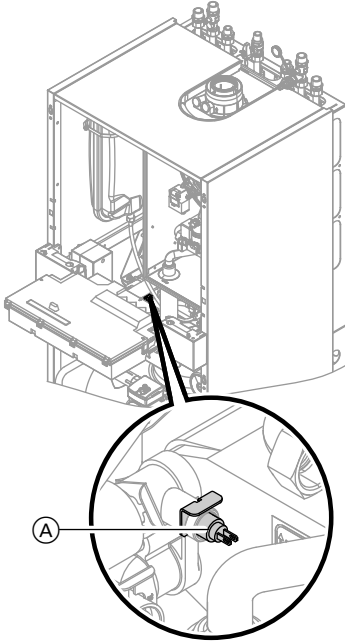

2. Check the sensor resistance and compare it with the curve.
3. Replace the sensor in case of severe deviation.



Danger

The outlet temperature sensor is immersed in the DHW (risk of scalding). Drain the DHW side of the boiler before replacing the sensor.

Repairs (cont.)

Checking the flue gas temperature sensor

The flue gas temperature sensor locks out the boiler when the permissible flue gas temperature is exceeded. Reset the interlock after the flue system has cooled down by pressing reset button **R**.

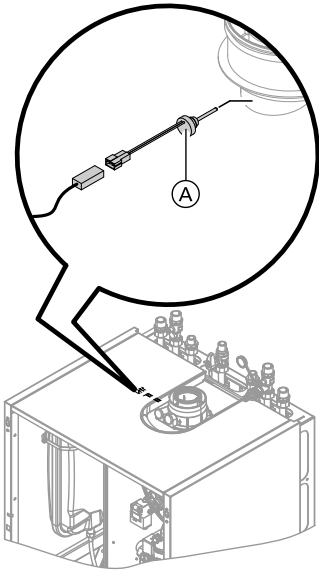

1. Pull the leads from flue gas temperature sensor (A).

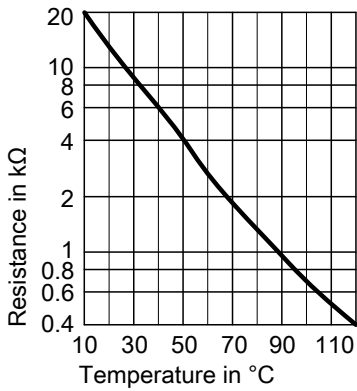

2. Check the sensor resistance and compare it with the curve.
3. Replace the sensor in case of severe deviation.

Repairs (cont.)

Checking the plate heat exchanger

Note

Drain the boiler on its heating water and DHW side.

During removal, small amounts of water may trickle out and escape from the plate heat exchanger.

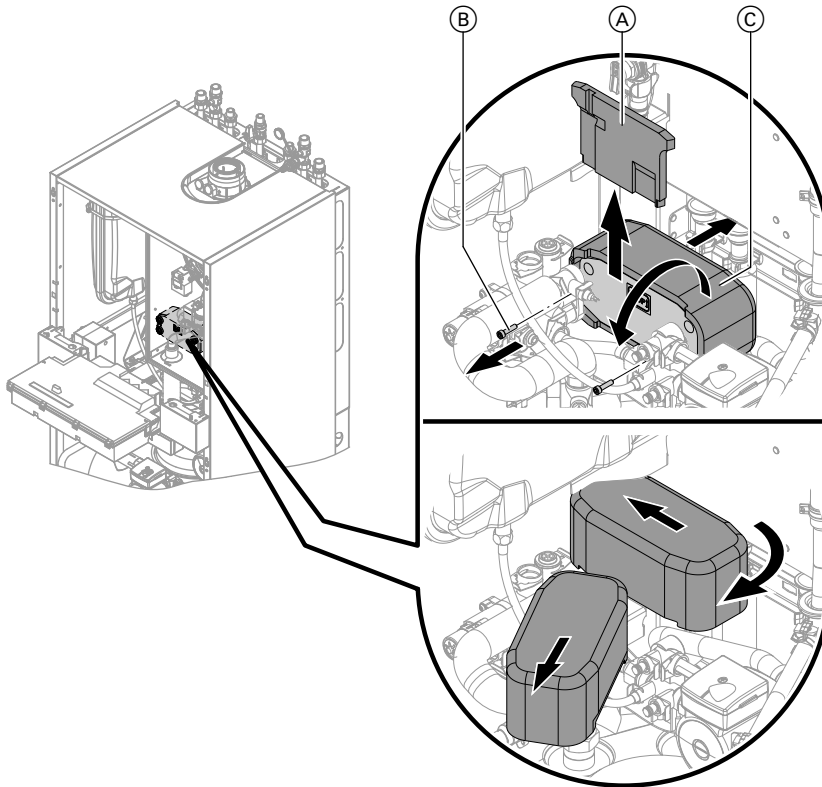

1. Shut off and drain the boiler on its heating water and DHW side.
2. Release the side closures and pivot the control unit forward.
3. Remove the siphon (see page 29).
4. Push insulating mat (A) upwards and remove.
5. Undo two screws (B) and pull out plate heat exchanger (C) with insulation to the front.

Repairs (cont.)

6. Check the connections on the heating water and DHW side for contamination and scaling; if required, replace the plate heat exchanger.
7. Install in reverse order with new gaskets.

Checking the temperature limiter

If the burner control unit cannot be reset after a fault shutdown, although the boiler water temperature is below approx. 75 °C, check the following:

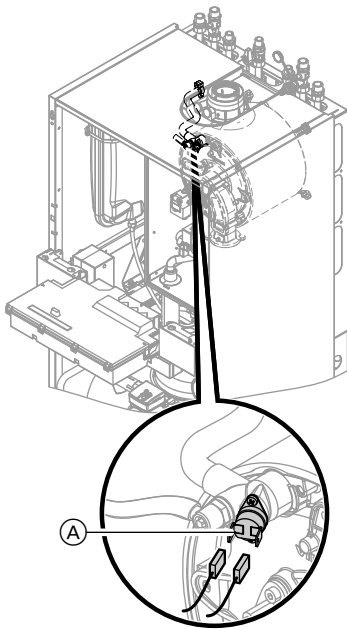

1. Pull the leads from temperature limiter **A**.
2. Check the continuity of the temperature limiter with a multimeter.
3. Remove the faulty temperature limiter.
4. Coat the replacement temperature limiter with heat conducting paste and install it.
5. After commissioning, press reset button **R** on the control unit.

Repairs (cont.)

Checking the fuse

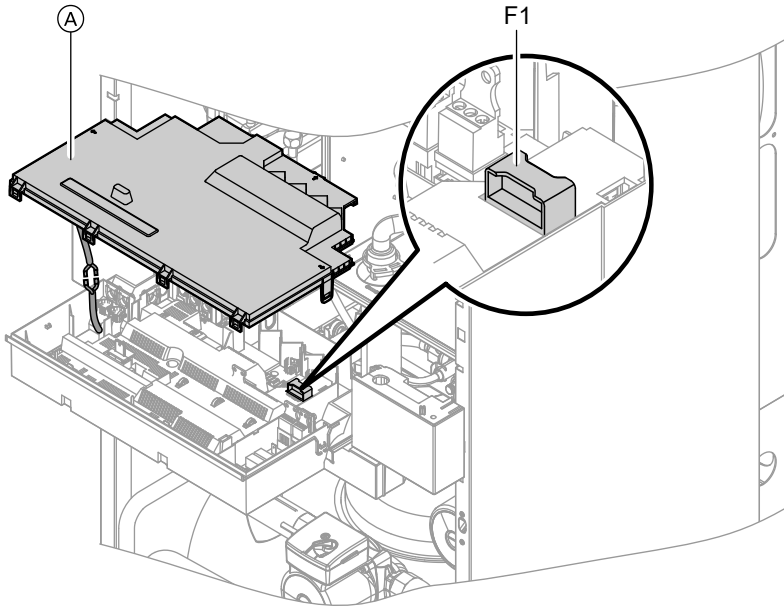

1. Switch OFF the power.
2. Release the side closures and pivot the control unit down.
3. Remove cover (A).
4. Check fuse F1 (see connection and wiring diagram).

Repairs (cont.)

Checking the solar control module fuse

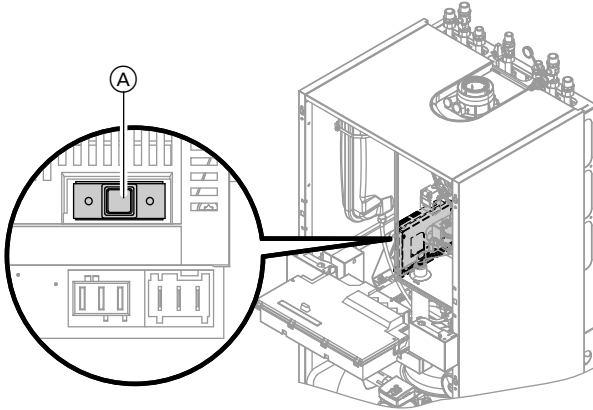

1. Switch OFF the power.
2. Check fuse **A** in the solar control module (see connection and wiring diagram).



Extension kit for heating circuit with mixer

Checking the setting of rotary selector S1

The rotary selector on the PCB of the extension kit defines the assignment to the relevant heating circuit.

Checking the rotational direction of the mixer motor

After being switched ON, the boiler implements a self-test. During this, the mixer is opened and closed again.

Heating circuit	Rotary selector S1 setting
Heating circuit with mixer M2 (heating circuit 2)	2 
Heating circuit with mixer M3 (heating circuit 3)	4 

5412 755 GB

Service

Repairs (cont.)

Note the rotational direction of the mixer motor during its self-test.
Then set the mixer manually to "Open" again.

Note

The flow temperature sensor must now capture a higher temperature. If the temperature drops, either the motor is turning in the wrong direction or the mixer set is incorrectly fitted.



Mixer installation instructions

Changing the rotational direction of the mixer motor (if required)

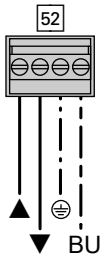

1. Remove the upper casing cover of the extension kit.



Danger

An electric shock can be life-threatening.
Before opening the boiler, disconnect from the mains voltage, for example at the fuse or the main isolator.

2. At plug 52, swap the cores at terminals "▲" and "▼".
3. Refit the casing cover.

Checking the Vitotronic 200-H (accessories)

The Vitotronic 200-H is connected to the control unit via the LON cable. To test the connection, carry out a subscriber check at the boiler control unit (see page 62).

Control unit

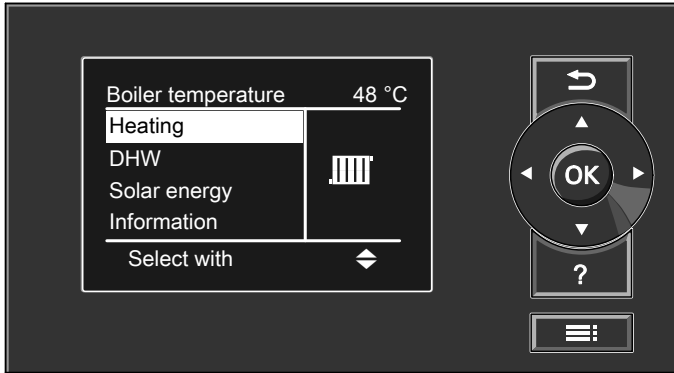

Heating mode

The control unit determines a set boiler water temperature subject to outside temperature or room temperature (if a room temperature-dependent remote control is connected) and to the slope/level of the heating curve.

The determined set boiler water temperature is transferred to the burner control unit. From the set and actual boiler water temperatures, the burner control unit calculates the modulation level and regulates the burner accordingly.

The electronic temperature limiter inside the burner control unit limits the boiler water temperature.

Heating the DHW primary cylinder from cold

The heating circuit pump is switched ON and the three-way diverter valve will be changed over, if the cylinder temperature sensor captures a temperature lower than the defaulted set temperature.

- The cylinder primary pump is switched ON if the boiler water temperature \geq set DHW temperature.
- The burner is switched ON if the boiler water temperature \leq set DHW temperature, and the cylinder primary pump is switched ON when the required boiler water temperature is reached.

Control unit (cont.)

The primary cylinder is heated up to the set DHW temperature. Heating stops when the set temperatures have been reached at the cylinder temperature sensor and at the outlet temperature sensor.

After heating, the cylinder primary pump and the three-way diverter valve remain ON for a further 30 s.

Boosting when DHW is drawn off

When DHW is drawn off, cold water enters at the bottom of the primary cylinder.

The heating circuit pump is switched ON and the three-way diverter valve is changed over, if the cylinder temperature sensor recognises a temperature lower than the set temperature.

- The cylinder primary pump is switched ON if the boiler water temperature \geq set DHW temperature.
- The burner is switched ON if the boiler water temperature \leq set DHW temperature, and the cylinder primary pump is switched ON when the required boiler water temperature is reached.

The DHW is controlled to the specified temperature via the cylinder temperature sensor.

The primary cylinder continues to be heated up after the draw off process has terminated, until the set DHW temperature has been reached at the cylinder temperature sensor.

The cylinder primary pump and the three-way diverter valve remain ON for a further 30 s.

DHW heating via solar collectors

If a temperature differential is measured between the collector temperature sensor and the cylinder temperature sensor of the solar control module, which is greater than the start temperature differential set in the control unit, the solar circuit pump is started and the DHW cylinder is heated.

The pump is stopped if the temperature falls below the stop temperature differential between the collector temperature sensor and the cylinder temperature sensor of the solar control module.

The solar circuit pump is stopped if the set maximum temperature or the temperature set at the temperature limiter is reached.

Control unit (cont.)

Boosting DHW heating

The booster heating function is activated if a switching period is selected for the fourth time phase.

The set temperature value for the heating boost is adjustable in coding address "58".

Internal extensions

Internal extension H1

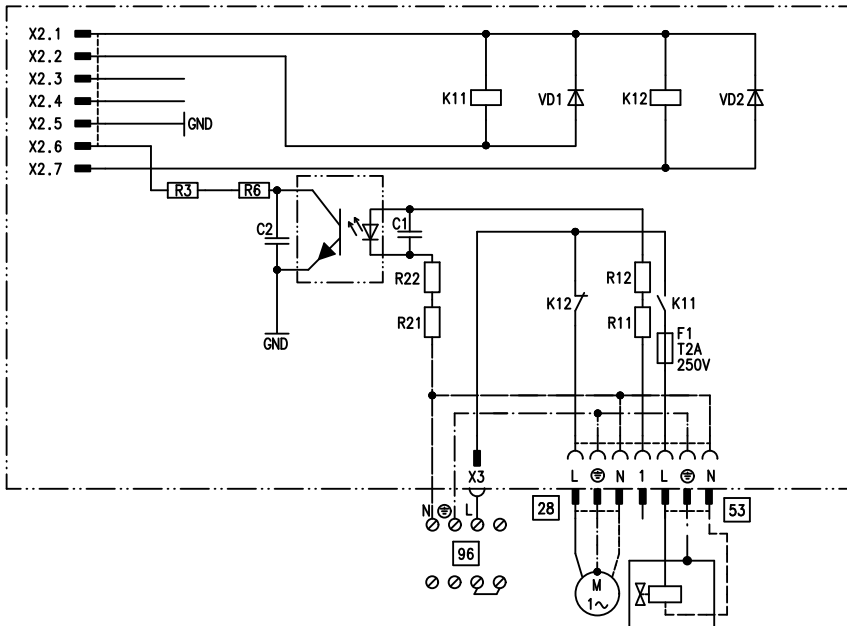

The internal extension H1 is integrated into the control unit casing. The cylinder primary pump is connected to relay output **28**.

An external safety valve can be connected to **53**.

Function description

Internal extensions (cont.)

Internal extension H2 (accessories)

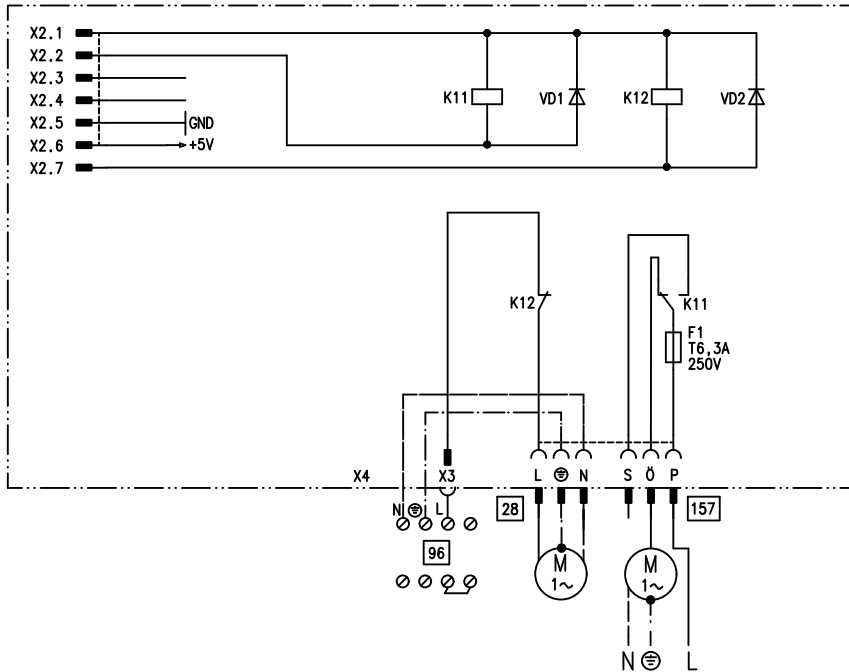

The internal extension H2 is integrated into the control unit casing instead of the internal extension H1. The cylinder primary pump is connected to relay output **28**.

An external extractor interlock can be connected to **157**.

External extensions (accessories)

Extension AM1

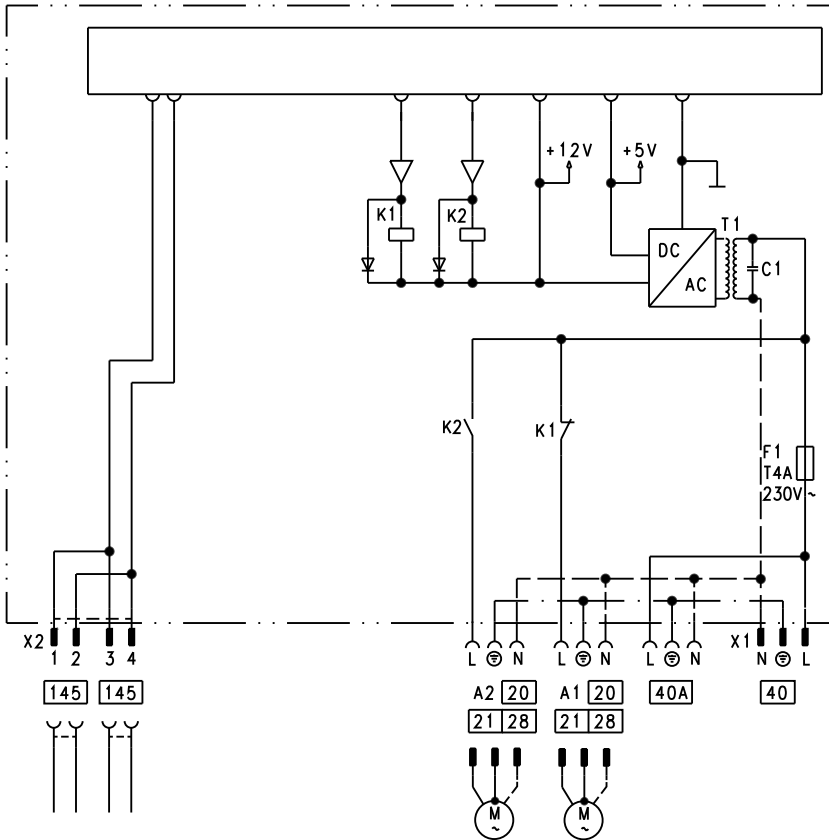

- A1 Circulation pump
- A2 Circulation pump
- 40 Power supply [terminals]

- 40A Power supply terminal for additional accessories
- 145 KM BUS

Service

Function description

External extensions (accessories) (cont.)

Functions

One of the following circulation pumps can be connected to each of the terminals A1 and A2:

- Heating circuit pump for the heating circuit without mixer
- Circulation pump for cylinder heating
- DHW circulation pump

Allocating functions for outputs A1 and A2

Select the function for these outputs via the codes on the boiler control unit:

- Output A1: Code 33
- Output A2: Code 34

Function	Code	
	Output A1	Output A2
DHW circulation pump 28	33:0	34:0 (delivered cond.)
Heating circuit pump 20	33:1 (delivered cond.)	34:1
Circulation pump for cylinder heating 21	33:2	34:2

External extensions (accessories) (cont.)

Extension EA1

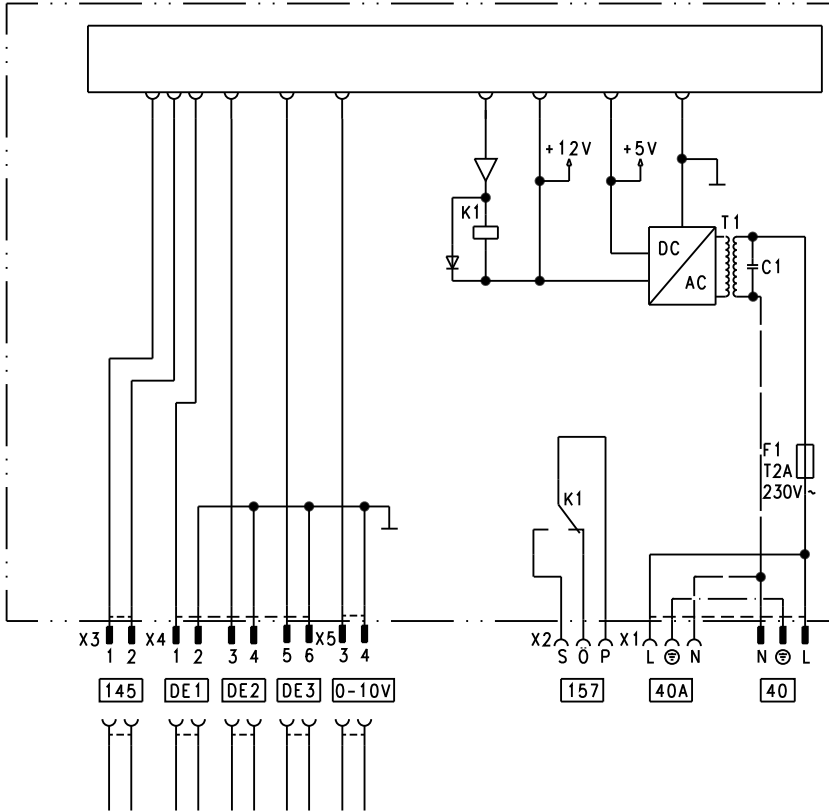

DE1 Digital input 1

DE2 Digital input 2

DE3 Digital input 3

0 - 10 V 0 - 10 V input

40 Power supply [terminals]

40A Power supply terminal for additional accessories

157 Central fault message/feed pump/DHW circulation pump (zero volt)

145 KM BUS

External extensions (accessories) (cont.)

Digital data inputs DE1 to DE3

The following functions can be connected alternatively:

- External heating program changeover for each heating circuit
- External blocking
- External blocking with fault message input
- External demand with minimum boiler water temperature
- Fault message input
- Short operation of the DHW circulation pump

The hooked-up contacts must correspond to protection class II.

Input function assignment

Select the input functions via the codes on the boiler control unit:

- DE1: Code 3A
- DE2: Code 3b
- DE3: Code 3C

Assigning the heating program changeover function to the heating circuits

Assign the heating program changeover function for the respective heating circuit via code d8 at the boiler control unit:

- Changeover via input DE1: Code d8:1
- Changeover via input DE2: Code d8:2
- Changeover via input DE3: Code d8:3

Select the effect of the heating program changeover via code d5:
Set the duration of the changeover via code F2.

Effect on the pumps of external blocking function

The effect on the internal circulation pump is selected with code 3E.
The effect on the relevant heating circuit pump is selected with code d6.
The effect on a circulation pump for cylinder heating is selected with code 5E.

Effect on the pumps of the external demand function

The effect on the internal circulation pump is selected with code 3F.
The effect on the relevant heating circuit pump is selected with code d7.
The effect on a circulation pump for cylinder heating is selected with code 5F.

DHW circulation pump runtime for brief operation

The runtime is set in code 3d.

Analogue input 0 - 10 V

The 0 - 10 V hook-up provides an additional set boiler water temperature:
0 - 1 V taken as "no default set boiler water temperature".

- 1 V ≙ set value 10 °C
- 10 V ≙ set value 100 °C

Output 157

The following functions can be connected to output 157:

- Feed pump to substation
or
- DHW circulation pump
or
- Fault message facility

External extensions (accessories) (cont.)

Function assignment

Select the function of output 157 via code 36 at the boiler control unit.

Control functions

External heating program changeover

The "External heating program changeover" function is connected via extension EA1. There are 3 inputs available at extension EA1 (DE1 to DE3).

The function is selected via the following codes:

Heating program changeover	Code
Input DE1	3A:1
Input DE2	3b:1
Input DE3	3C:1

Assign the heating program changeover function for the respective heating circuit via code d8 at the boiler control unit:

Heating program changeover	Code
Changeover via input DE1	d8:1
Changeover via input DE2	d8:2
Changeover via input DE3	d8:3

You can select which direction the heating program changeover takes in coding address "d5":

Heating program changeover	Code
Changeover towards "Permanently reduced" or "Permanent standby" mode (subject to the selected set value)	d5:0
Changeover towards "Constant heating mode"	d5:1

The duration of the heating program changeover can be adjusted in coding address "F2":

Function description

Control functions (cont.)

Heating program changeover	Code
No heating program changeover	F2:0
Duration of the heating program changeover 1 to 12 hours	F2:1 to F2:12

The heating program changeover stays enabled for as long as the contact remains closed, but at least as long as the duration selected in coding address "F2".

External blocking

The "External blocking" and "External blocking and fault message input" functions are connected via extension EA1. There are 3 inputs available at extension EA1 (DE1 to DE3).

The function is selected via the following codes:

External blocking	Code
Input DE1	3A:3
Input DE2	3b:3
Input DE3	3C:3

External blocking and fault message input	Code
Input DE1	3A:4
Input DE2	3b:4
Input DE3	3C:4

The effect on the internal circulation pump is selected with code 3E.

The effect on the relevant heating circuit pump is selected with code d6.

External demand

The "External demand" function is connected via extension EA1. There are 3 inputs available at extension EA1 (DE1 to DE3).

The function is selected via the following codes:

Control functions (cont.)

External demand	Code
Input DE1	3A:2
Input DE2	3b:2
Input DE3	3C:2

The effect on the internal circulation pump is selected with code 3F. The effect on the relevant heating circuit pump is selected with code d7.

The minimum set boiler water temperature in case of external demand is selected in coding address "9b".

Venting program

During the venting program, the circulation pump will be alternately switched ON and OFF for 30 s respectively over a period of 20 min.

For a certain period, the diverter valve is alternately set towards heating and DHW heating. The burner is switched OFF during the venting program.

Activate venting program: See "Venting the heating system".

Fill program

In the delivered condition, the diverter valve is set to its central position, enabling the system to be filled completely. After switching ON the control unit, the diverter valve no longer goes into its central position.

Afterwards, the diverter valve can be moved via the fill function into the central position (see "Filling the heating system"). In this position, the control unit can be switched OFF, and the system can be filled completely.

Filling with the control unit switched ON

If the system is to be filled with the control unit switched ON, the diverter valve is moved in the fill program to its central position and the pump starts.

When the function is enabled, the burner shuts down. The program is automatically disabled after 20 min.

Screed drying function

The screed function enables screeds to be dried. For this, always observe the details specified by the screed manufacturer.

Function description

Control functions (cont.)

When the screed drying function is activated, the heating circuit pump of the mixer circuit is switched ON and the flow temperature will be held in accordance with the selected profile. After completion (30 days), the mixer circuit will again be regulated automatically via the set parameters.

Observe EN 1264. The report to be provided by the heating contractor must contain the following heat-up details:

- Heat-up data with respective flow temperatures
- Max. flow temperature achieved
- Operating conditions and outside temperature during handover

The various temperature profiles are adjustable via coding address "F1". The function continues after power failure or after the control unit has been switched OFF. "Heating and DHW" will be started after the screed drying function has been terminated or if code "F1:0" is manually adjusted.

Temperature profile 1: (EN 1264-4) code F1:1

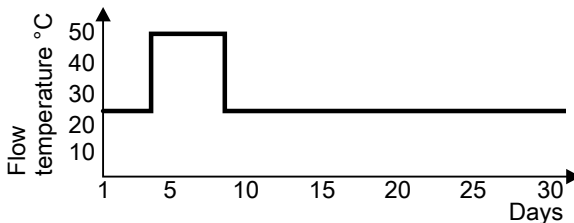

Temperature profile 2: (ZV parquet and flooring technology) code F1:2

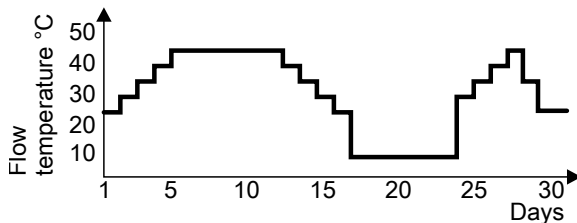

Control functions (cont.)

Temperature profile 3: Code F1:3

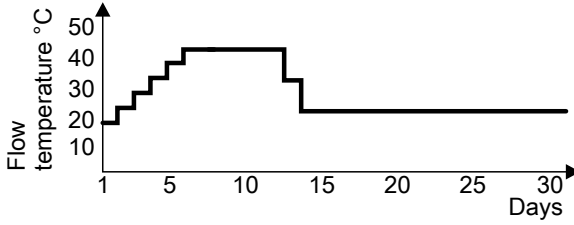

Temperature profile 4: Code F1:4

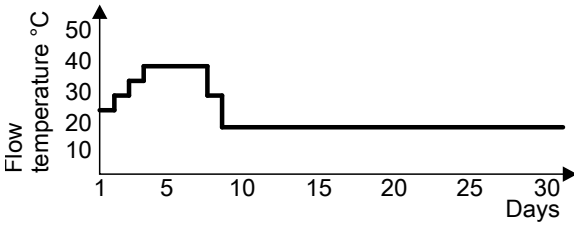

Temperature profile 5: Code F1:5

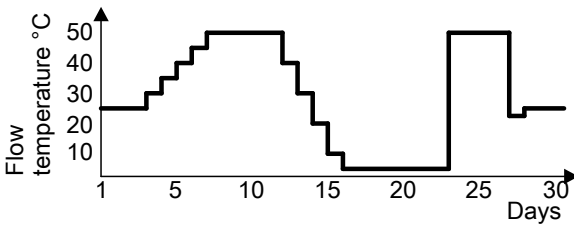

Service

Function description

Control functions (cont.)

Temperature profile 6: Code F1:6

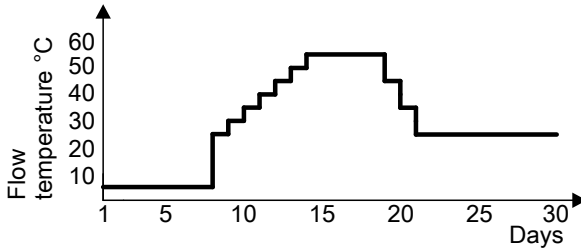

Temperature profile 7: Code F1:15

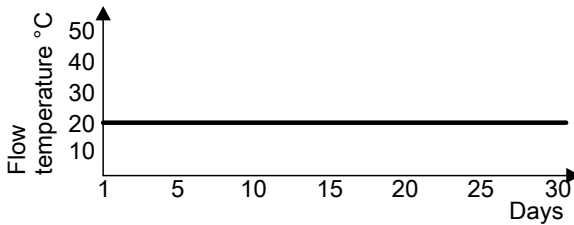

Raising the reduced room temperature

During operation with reduced room temperature, the reduced set room temperature can be automatically raised subject to the outside temperature. The temperature is raised in accordance with the selected heating curve, but no higher than the set standard room temperature.

The outside temperature limits for the start and end of the temperature raising can be adjusted via coding addresses "F8" and "F9".

Control functions (cont.)

Example using the settings in the delivered condition

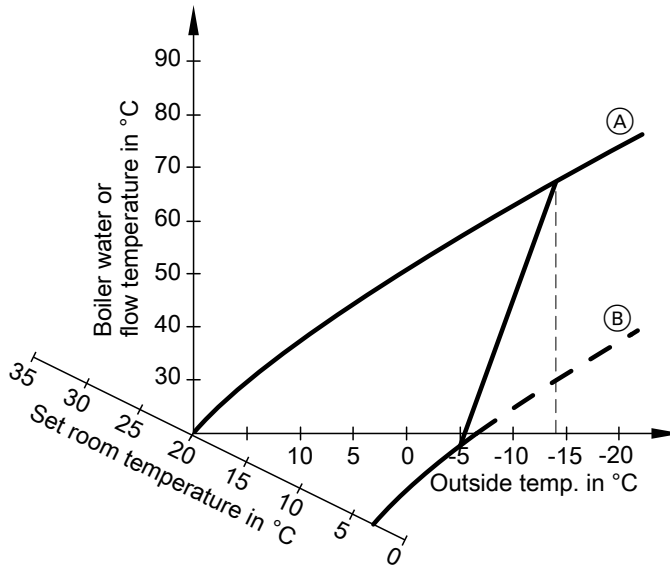

Ⓐ Heating curve for operation with standard room temperature

Ⓑ Heating curve for operation with reduced room temperature

Reducing the heat-up time

During the transition from operation with reduced room temperature to operation with standard room temperature, the boiler water or flow temperature will be raised in accordance with the selected heating curve. The boiler water or flow temperature can be automatically increased.

The value and duration of the additional increase of the set boiler water or flow temperature can be adjusted in coding addresses "FA" and "Fb".

Function description

Control functions (cont.)

Example using the settings in the delivered condition

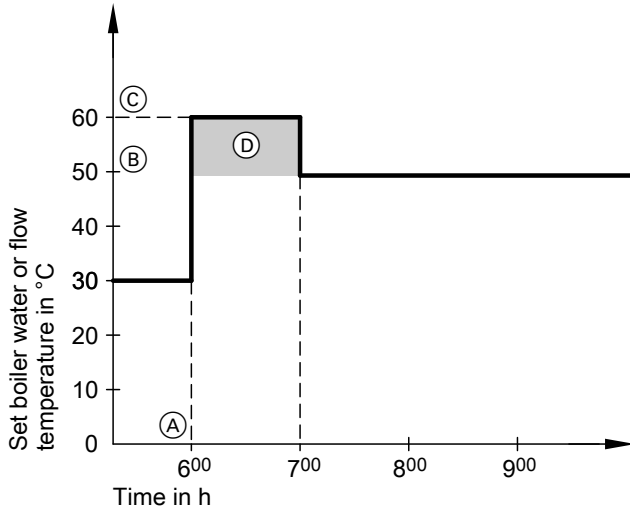

- Ⓐ Start of operation with standard room temperature
- Ⓑ Set boiler water or flow temperature in accordance with the selected heating curve
- Ⓒ Set boiler water or flow temperature in accordance with coding address "FA":
 $50\text{ °C} + 20\% = 60\text{ °C}$
- Ⓓ Duration of operation with raised set boiler water or flow temperature in accordance with coding address "Fb":
60 min

Allocating heating circuits to the remote control

The heating circuit allocation must be configured when commissioning the Vitotrol 200A or Vitotrol 300A.

Heating circuit	Configuration	
	Vitotrol 200A	Vitotrol 300A
The remote control affects the heating circuit without mixer A1	H 1	HK1
The remote control affects the heating circuit with mixer M2	H 2	HK2
The remote control affects the heating circuit with mixer M3	H 3	HK3

Note

One heating circuit can be allocated to the Vitotrol 200A.

Up to three heating circuits can be allocated to the Vitotrol 300A.

If the heating circuit allocation is later cancelled, reset coding address A0 for this heating circuit to 0 (fault message bC, bd, bE).

Electronic combustion controller

The electronic combustion controller utilises the physical correlation between the level of the ionisation current and the air factor λ . For all gas qualities, the maximum ionisation current results with air factor 1.

The ionisation signal is evaluated by the combustion controller, and the air factor is adjusted to between $\lambda=1.24$ and 1.44. This range provides for an optimum combustion quality. Thereafter, the electronic gas valve regulates the required gas volume subject to the prevailing gas quality.

To check the combustion quality, the CO₂ content or the O₂ content of the flue gas is measured. The actual values enable the prevailing air factor to be determined. The relationship between the CO₂ or O₂ content and air factor λ is illustrated in the following table.

Electronic combustion controller (cont.)**Air factor λ – CO₂/O₂ content**

Air factor λ	O ₂ content (%)	CO ₂ content (%) for natural gas H	CO ₂ content (%) for LPG P
1.24	4.4	9.2	10.9
1.27	4.9	9.0	10.6
1.30	5.3	8.7	10.3
1.34	5.7	8.5	10.0
1.37	6.1	8.3	9.8
1.40	6.5	8.1	9.6
1.44	6.9	7.8	9.3

To achieve an optimum combustion control, the system regularly carries out an automatic self-calibration; also after a power failure (shutdown). For this, the combustion is briefly regulated to max. ionisation current (equals air factor $\lambda=1$). The automatic calibration is carried out shortly after the burner start and lasts approx. 5 s. During calibration, higher than normal CO emissions may occur briefly.

Internal connection diagram

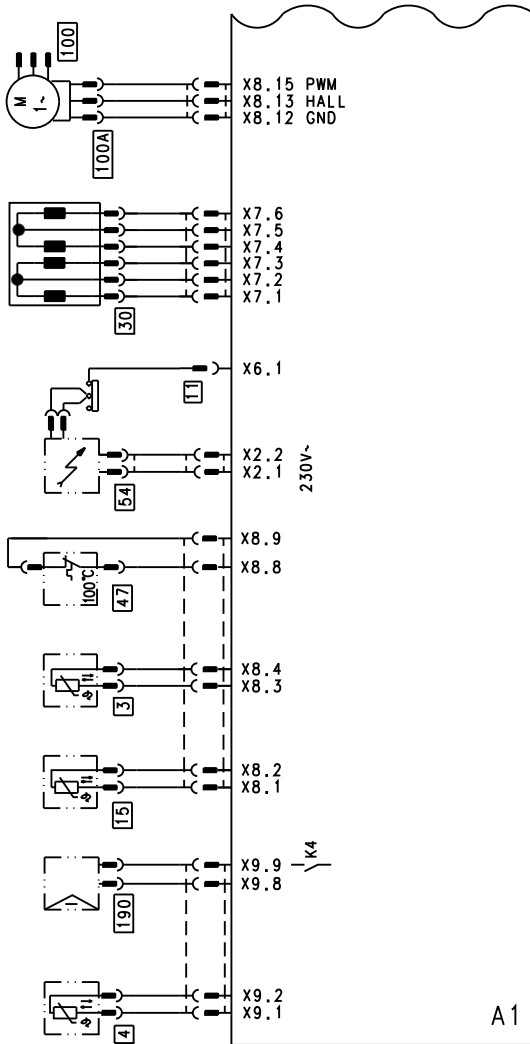

- | | | | |
|------|---------------------------------|------|----------------------------------|
| A1 | Main PCB | 30 | Stepper motor for diverter valve |
| X... | Electrical interfaces | 47 | Temperature limiter |
| 3 | Boiler water temperature sensor | 54 | Ignition unit |
| 4 | Outlet temperature sensor | 100 | Fan motor |
| 11 | Ionisation electrode | 100A | Fan motor control |
| 15 | Flue gas temperature sensor | 190 | Modulation coil |

5412 755 GB

Service

External connection diagram

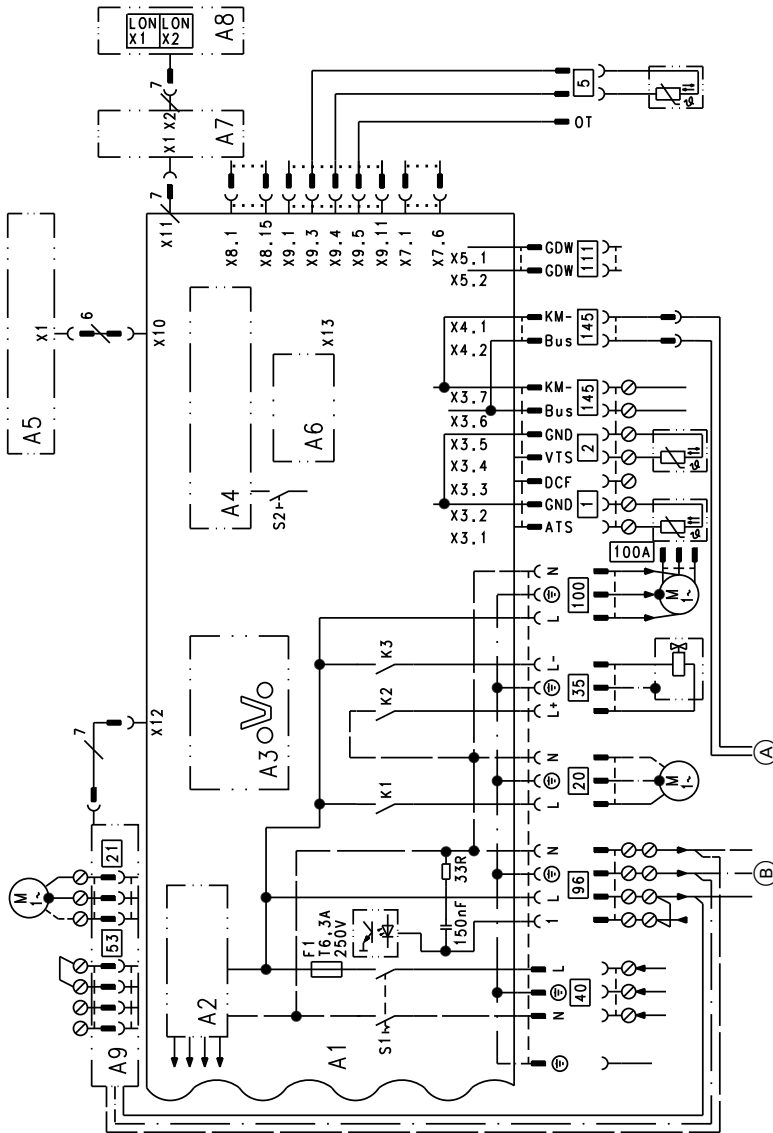

- | | | | |
|----|-------------------|----|---------------------|
| A1 | Main PCB | A4 | Burner control unit |
| A2 | Power supply unit | A5 | Programming unit |
| A3 | Optolink | A6 | Coding card |

External connection diagram (cont.)

A7	Connection adaptor	5	Cylinder temperature sensor (plug on the cable harness)
A8	LON communication module	20	Internal circulation pump
A9	Internal extension H1	21	Cylinder primary pump
S1	ON/OFF switch	35	Gas solenoid valve
S2	Reset button	40	Power supply
X...	Electrical interfaces	96	Power supply accessories and Vitotrol 100
(A)	KM BUS to the solar control module	100	Fan motor
(B)	Solar control module power supply	100A	Fan motor control
1	Outside temperature sensor	111	Gas pressure limiter
2	Flow temperature sensor, low loss header	145	KM BUS

Connection diagram, solar control module

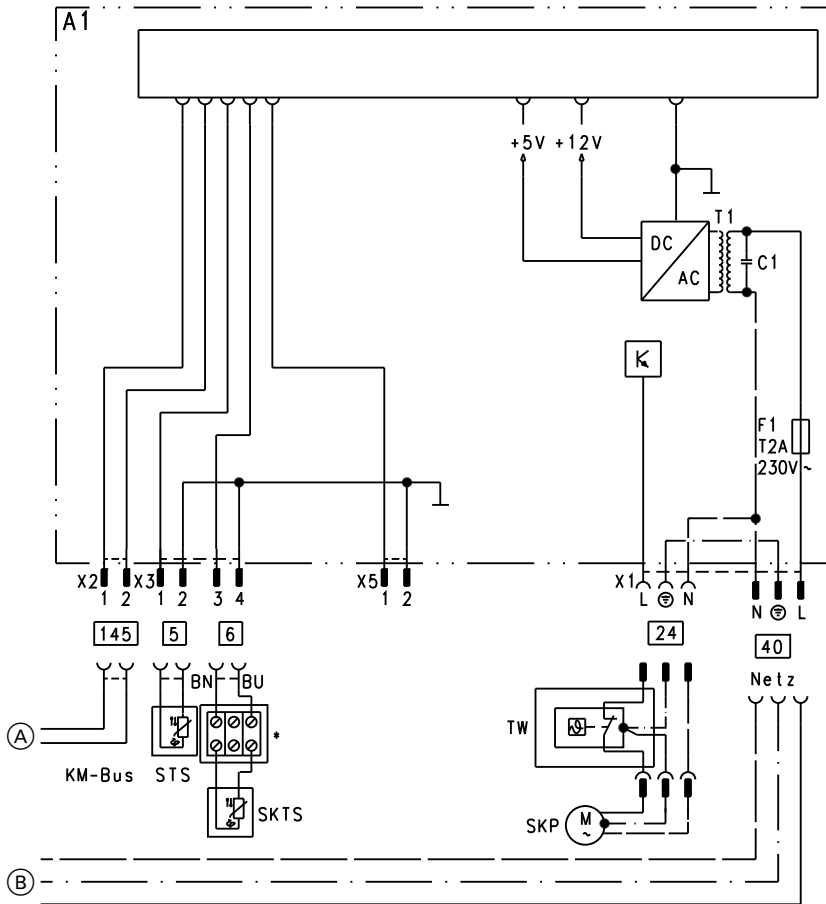

A1 Main PCB

TW Temperature limiter

X... Electrical interfaces

(A) KM BUS from the control unit

(B) Power supply from the control unit

5 Cylinder temperature sensor

6 Collector temperature sensor

24 Solar circuit pump

40 Power supply

145 KM BUS

Parts lists

Spare parts information

Quote the part and serial no. (see type plate) and the item number of the required part (as per this parts list). Obtain standard parts from your local supplier.

- | | | | |
|-----|--|-----|---|
| 001 | Diaphragm expansion vessel | 034 | Heating water flow connecting pipe |
| 002 | Connection line; diaphragm expansion vessel | 035 | Connection pipework, heating water return |
| 003 | Cap panel with gasket | 036 | Connection pipework, cold water |
| 004 | Profiled seal | 037 | DHW connecting pipe |
| 005 | Boiler flue connection | 038 | Heating water flow connecting pipe |
| 006 | Plug | 039 | Cold water connection |
| 007 | Ventilation air gasket | 040 | Heating water return connecting pipe |
| 008 | Flue gas gasket | 041 | Connecting pipe, central draw-off |
| 009 | O-ring 8 x 2 (5 pce) | 042 | Solar return connecting pipe |
| 010 | Heat exchanger | 043 | Solar circuit pump connecting pipe |
| 011 | Moulded hose, return | 044 | Solar flow connecting pipe |
| 012 | Condensate hose | 045 | Connector for solar filling equipment |
| 013 | Siphon | 046 | Filling facility for solar heat transfer medium |
| 015 | Hose 19 x 800 mm, corrugated | 047 | Solar connection elbow |
| 016 | Condensate hose (400 mm long) | 048 | Sensor well |
| 017 | Hose 19 x 1100 mm, corrugated | 050 | Flow unit |
| 019 | Condensate manifold | 051 | Return unit |
| 020 | Spacer | 052 | Overflow valve |
| 021 | Safety valve | 053 | Plug \varnothing 8/10 mm |
| 022 | Right-angle shut-off valve, central draw-off | 054 | Plate heat exchanger |
| 023 | Hose ferrule | 055 | Profiled gasket |
| 024 | Right-angle shut-off valve, DHW cylinder heating | 056 | Valve insert |
| 025 | Connection line, DHW heating | 057 | Overflow pipe |
| 026 | Bezel | 058 | Plate heat exchanger insulation shell |
| 027 | Non-return valve | 059 | Plate heat exchanger insulation board |
| 028 | Air vent valve G $\frac{3}{8}$ | 062 | Burner gauze assembly |
| 029 | Pressure gauge | 063 | Burner gauze assembly gasket |
| 030 | Right-angle shut-off valve, cylinder cold water | 066 | Burner flange gasket |
| 031 | Gas pipe | 067 | Fan |
| 032 | Flow pipe | 068 | Gas train |
| 033 | Connecting pipe, cold water, cylinder | 069 | Burner door |
| | | 070 | Ignition unit |
| | | 071 | Ionisation electrode gasket |
| | | 072 | Ignition electrode gasket |
| | | 074 | Gas nozzle |
| | | 075 | Venturi extension |
| | | 080 | Gasket set A 16 x 24 x 2.0 |



Parts lists (cont.)

- | | |
|--|---|
| 081 Gasket set A 17 x 24 x 2.0 | 162 Sleeve |
| 082 Gasket set A 10 x 15 x 1.5 | 164 Cylinder gasket |
| 084 Gasket 23 x 30 x 2.0 | 166 Anode flange with gasket |
| 085 O-ring gasket set 17.86 x 2.62 | 167 Flange insulation |
| 086 O-ring 9.6 x 2.4 | 171 Sleeve |
| 087 O-ring 14.3 x 2.4 | 172 Cover |
| 088 O-ring 35.4 x 3.6 | 173 Sensor retainer |
| 089 Set of plug connector retainers | 174 Draw-off connector sleeve |
| 090 Toggle fastener (set) | 200 Side panel, left |
| 092 Grommet | 202 Side panel, right |
| 093 Pipe clip Ø 18 | 204 Top cover |
| 094 Pipe clip Ø 18/1.5 | 205 Front panel, top |
| 095 Hose clip DN 25 | 206 Front panel, bottom |
| 096 Clip Ø 8 | 207 Adjustable foot |
| 097 Clip Ø 10 | 208 Fixing elements |
| 098 Clip Ø 15 | 211 Top panel insert |
| 099 Clip Ø 18 | 300 Control unit |
| 100 Hose clip Ø 34.3 - 38.7 | 301 Casing back panel |
| 102 Locking clip, condensate drain | 302 Boiler coding card |
| 103 Drain plug (set) | 303 Fuse 6.3 A slow (10 pce.) |
| 104 Cap | 304 Fuse holder |
| 105 Hose Ø 10 x 1.5 x 750 | 305 Programming unit for weather-compensated mode |
| 106 Union nut G 1 | 307 LON communication module (accessories) |
| 107 Grommet | 308 PCB adaptor, LON module (accessories) |
| 110 Quick-action air vent valve | 309 Internal extension H1 |
| 111 Cylinder mounting bracket | 315 Locking bolts, left and right |
| 112 Control unit support | 316 Slider, left and right |
| 114 Check valve with casing | 318 Solar control module |
| 115 Pipe clip Ø 18 | 324 Solar cylinder temperature controller |
| 130 VIUPSO circulation pump | |
| 131 VIUP circulation pump | |
| 132 VI solar circuit pump | |
| 133 VIUPS circulation pump motor | |
| 134 VIUP circulation pump motor | |
| 135 Circulation pump motor | |
| 140 Flue gas temperature sensor | |
| 141 Thermal circuit breaker | |
| 142 Temperature sensor | |
| 143 Cylinder temperature sensor | |
| 145 Cylinder temperature sensor, solar | |
| 150 T&P valve connecting pipe | |
| 151 T&P valve | |
| 160 Cylinder | |
| | Wearing parts |
| | 060 Burner gasket |
| | 061 Insulation ring |
| | 064 Ignition electrode with gasket |
| | 065 Ionisation electrode with gasket |
| | 165 Magnesium anode |

Parts lists (cont.)

Parts not shown

- 108 Special grease
- 209 Touch-up paint stick, Vitowhite
- 210 Spray paint, Vitowhite
- 310 Cable harness X8/X9/ionisation
- 311 Cable harness 100/35/54 (auxiliary earth)
- 312 Cable harness stepper motor
- 313 Mating plug set
- 314 Cable fixing
- 317 Collector temperature sensor
- 319 Adaptor lead for collector temperature sensor
- 320 Plug set, LV
- 321 Plug set, 230 V
- 322 KM BUS connecting cable 145
- 323 Power cable 40
- 401 Operating instructions for weather-compensated mode
- 402 Installation and service instructions
- Ⓐ Type plate

Parts lists (cont.)

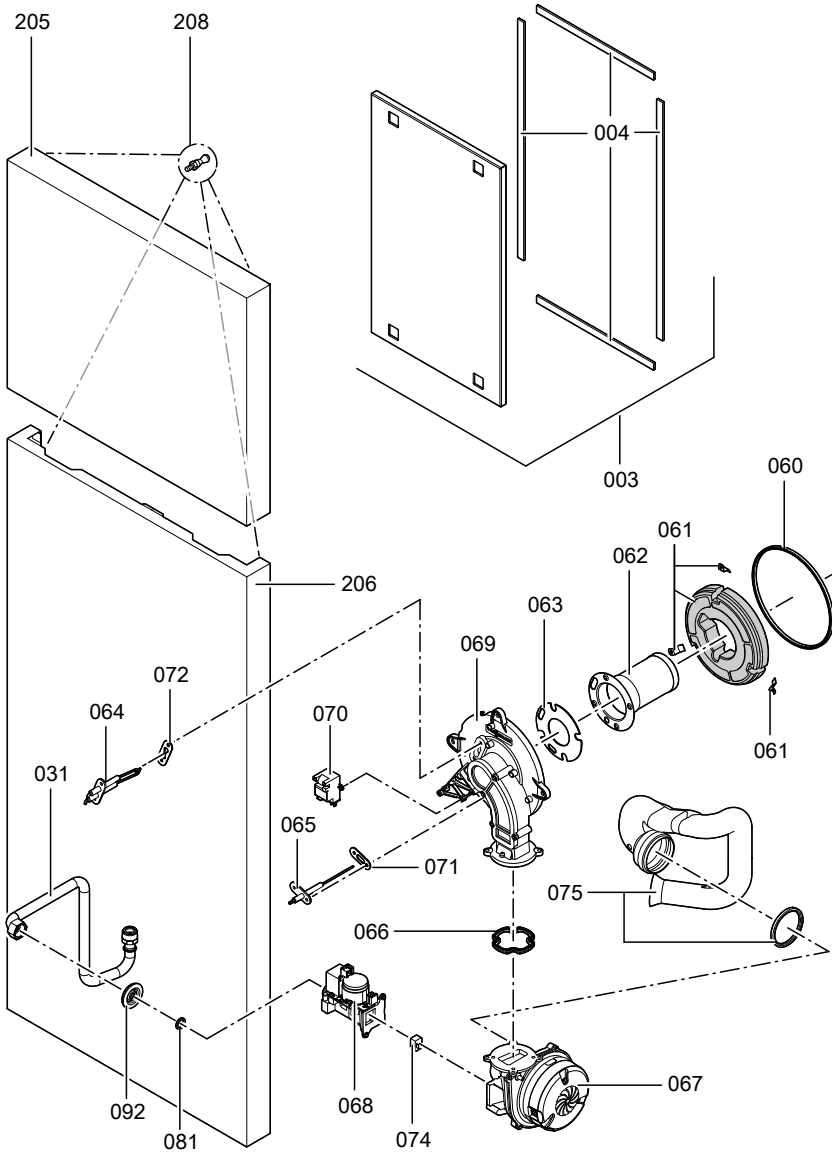

Parts lists (cont.)

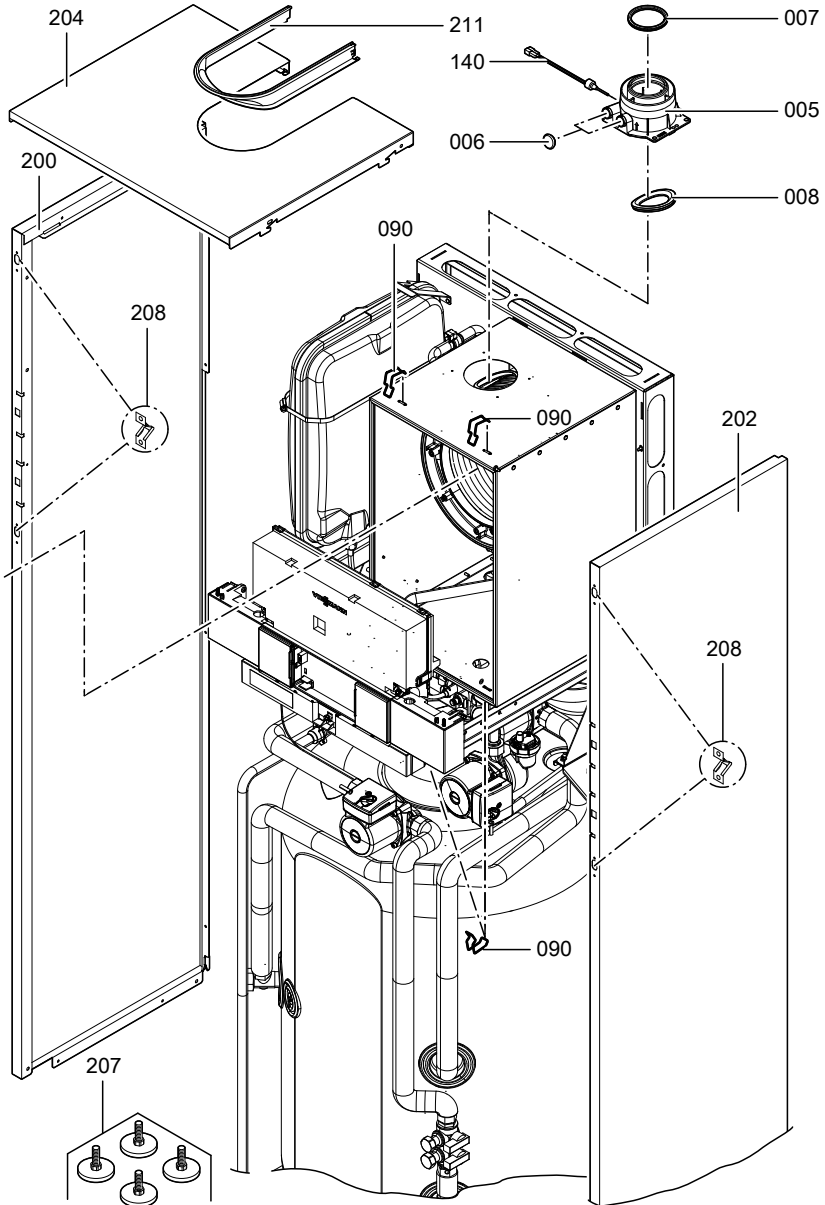

5412 755 GB

Service

Parts lists (cont.)

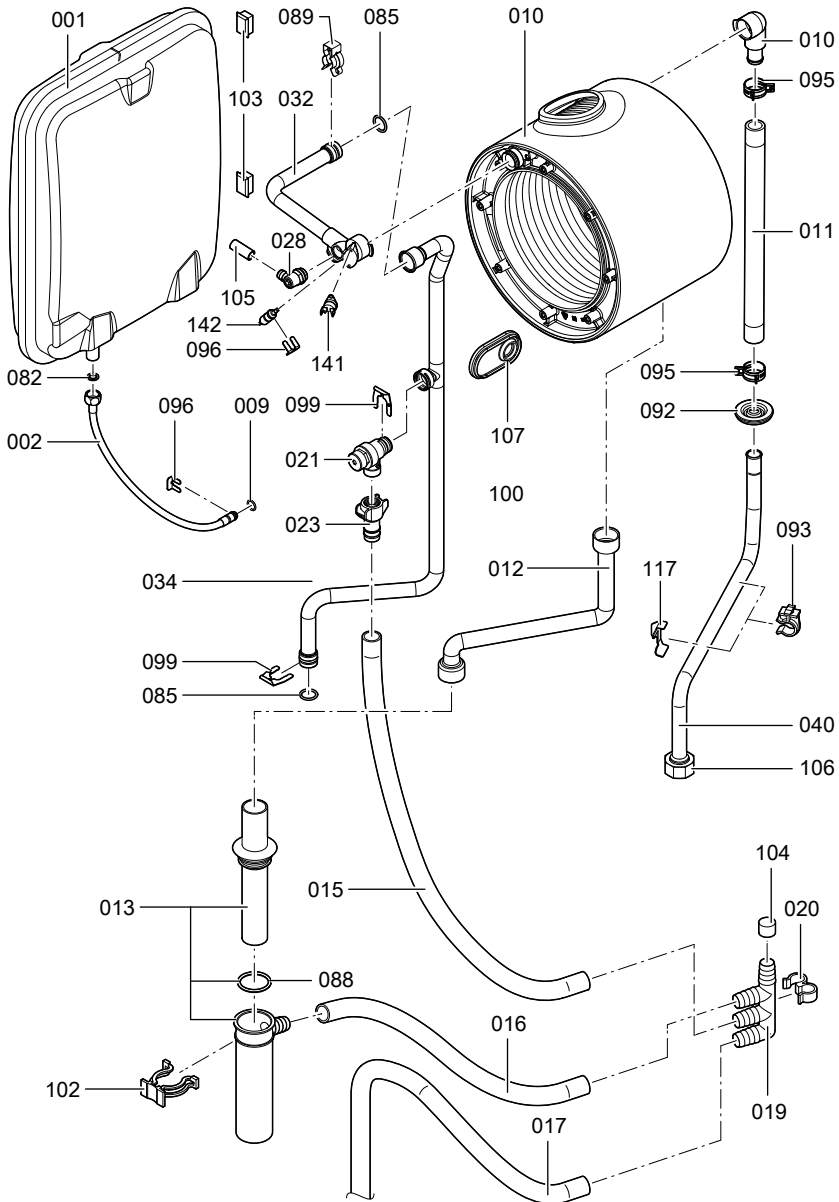

Parts lists (cont.)

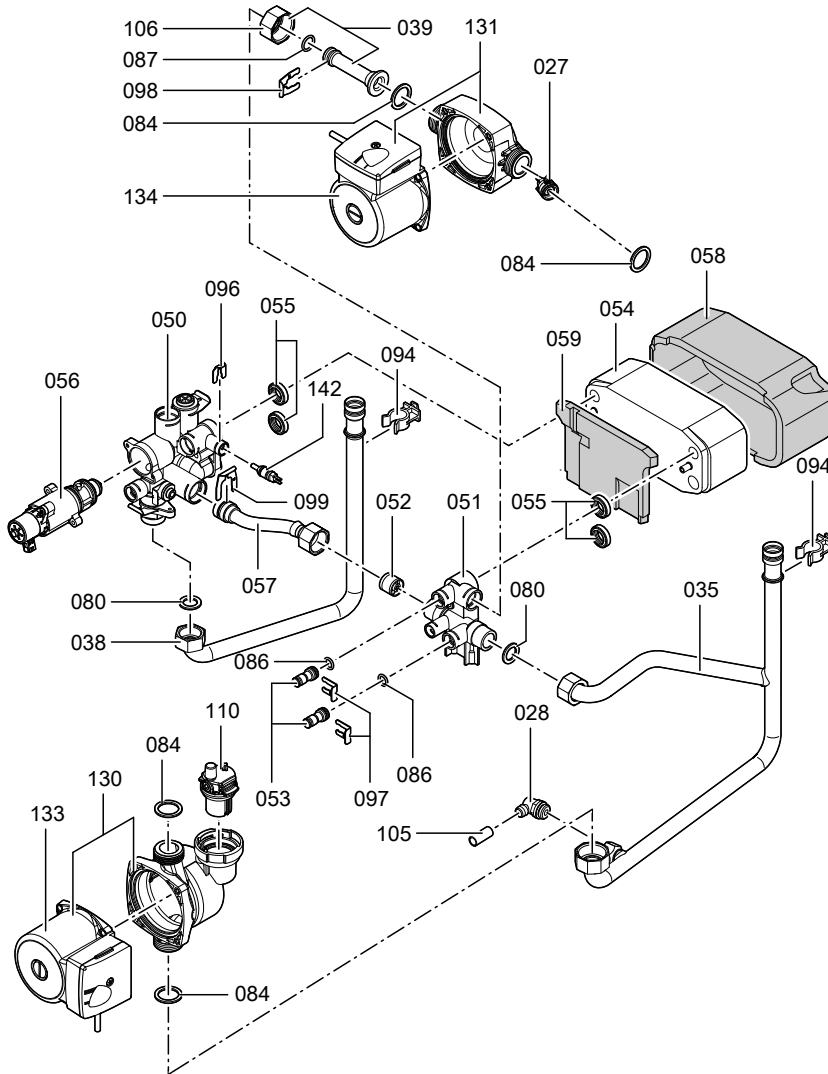

Parts lists (cont.)

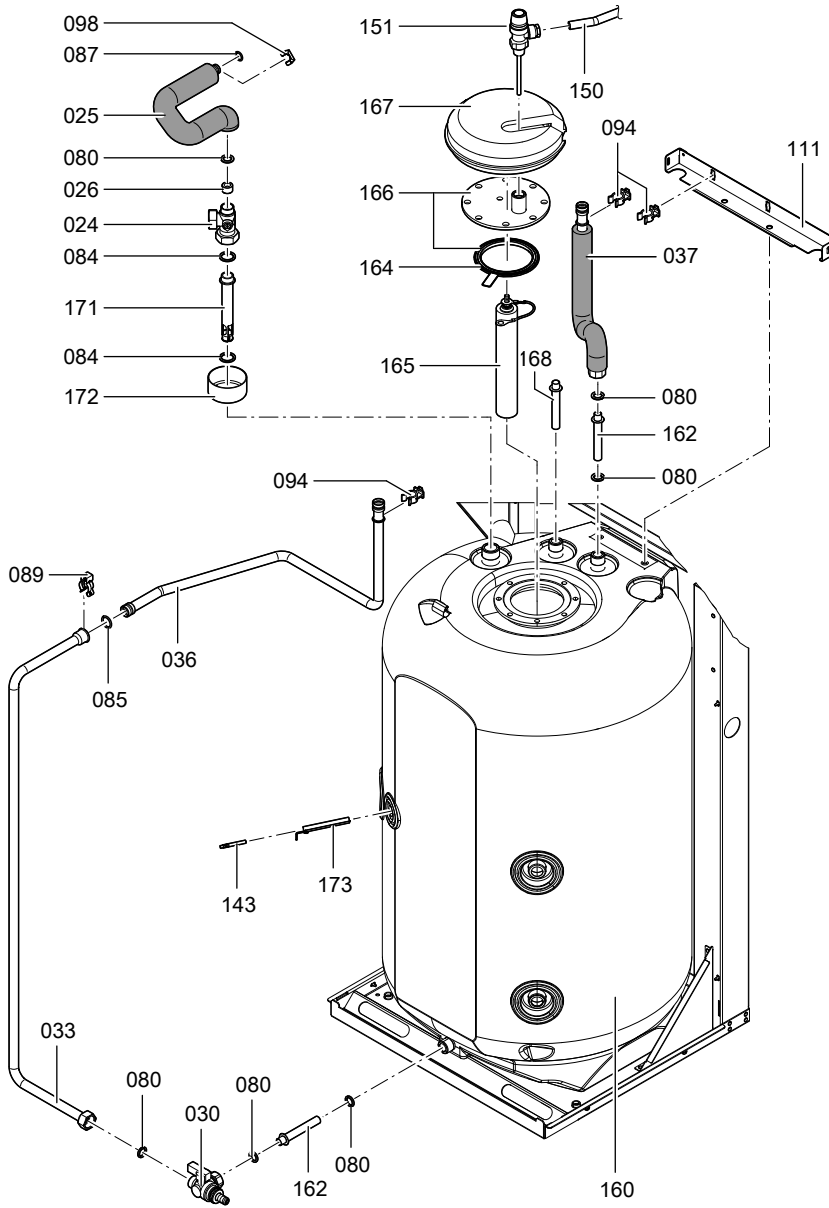

5412 755 GB

Service

Parts lists (cont.)

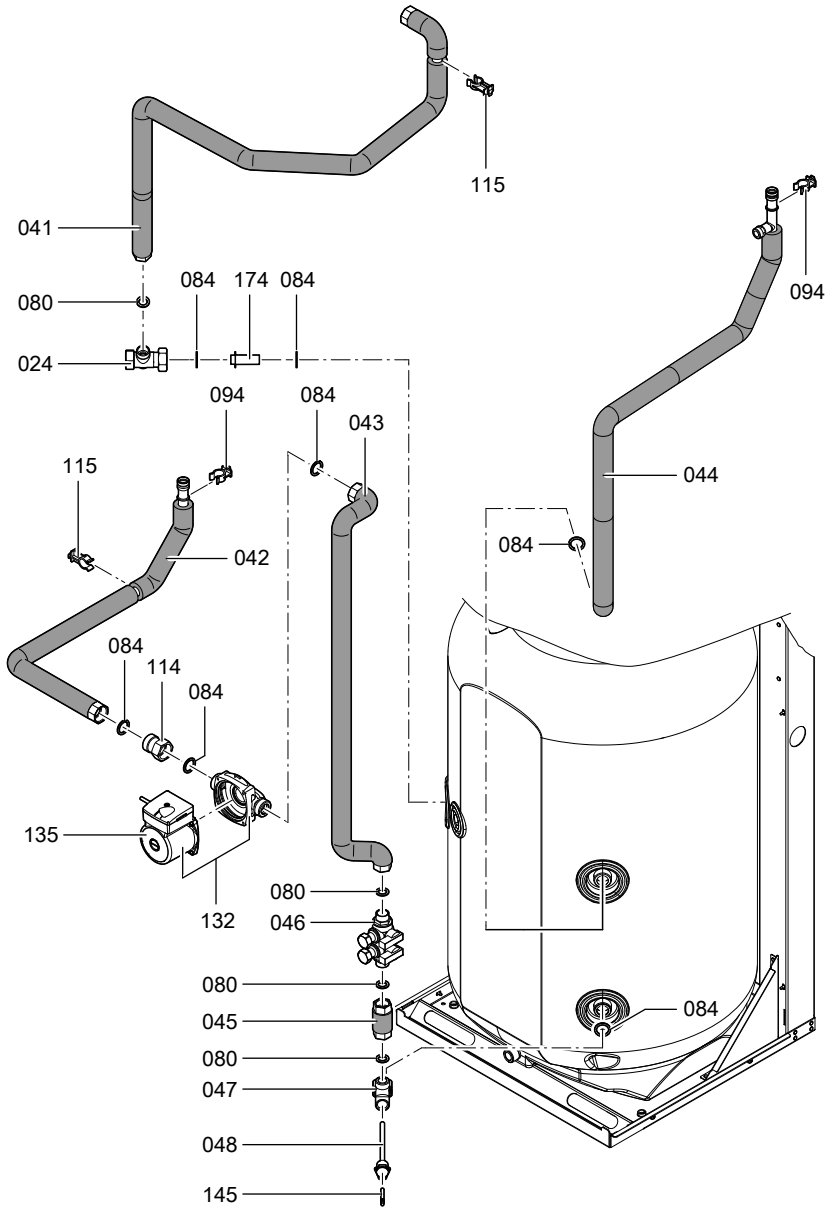

Commissioning/service reports

Setting and test values	Date: By:	Set value	Commissioning	Service
Static pressure	<i>mbar</i>	max. 57.5 mbar		
Supply pressure (flow pressure)				
<input type="checkbox"/> for natural gas H	<i>mbar</i>	17.4-25 mbar		
<input type="checkbox"/> for LPG	<i>mbar</i>	25-47 mbar		
<i>Tick gas type</i>				
Carbon dioxide content CO₂				
■ at lower output	<i>% by vol.</i>			
■ at upper output	<i>% by vol.</i>			
Oxygen content O₂				
■ at lower output	<i>% by vol.</i>			
■ at upper output	<i>% by vol.</i>			
Carbon monoxide content CO				
■ at lower output	<i>ppm</i>			
■ at upper output	<i>ppm</i>			

Service

Specification

Specification

Rated voltage	230 V	Electronic temperature limiter setting	82 °C
Rated frequency	50 Hz	Temperature limiter setting	100 °C (fixed)
Rated current	6 A	Line fuse (power supply)	max. 16 A
Protection class	I		
IP rating	IP X 4 D to EN 60529		
Permissible ambient temperature			
■ during operation	0 to +40 °C		
■ during storage and transport	-20 to +65 °C		

Rated output range			
at T_V/T_R 50/30 °C	kW	4.8 to 19	6.5 to 26
at T_V/T_R 80/60 °C	kW	4.3 to 17.5	5.9 to 24.1
Rated output for DHW heating	kW	4.3 to 17.5	5.9 to 26.4
Rated heat input range	kW	4.5 to 17.9	6.2 to 29.7
Power consumption	W	90	105
Connection values			
in relation to the max. load			
Natural gas H	m ³ /h	1.89	3.23
LPG	kg/h	1.40	2.39
Product ID	CE-0085BU0051		
Cylinder heat-up time, 15 to 60 °C	19 mins		
Cylinder heat-up time, 70% volume	15 mins		

Note

The supply values are only for documentation purposes (e.g. in the gas contract application) or to estimate the supplementary volumetric settings. Because of factory settings, the gas pressure must not be altered from these values. Reference: 15 °C, 1013 mbar.

Declaration of conformity

Declaration of conformity for the Vitodens 242-F

We, Viessmann Werke GmbH&Co KG, D-35107 Allendorf, declare as sole responsible body, that the product **Vitodens 242-F** complies with the following standards:

DIN 4753	EN 55 014
EN 483	EN 60 335-1
EN 625	EN 60 335-2-102
EN 677	EN 61 000-3-2
EN 806	EN 61 000-3-3
EN 12897	

In accordance with the following Directives, this product is designated **CE-0085**:

97/23/EC	2006/ 95/EC
92/42/EEC	2009/142/EC
2004/108/EC	

This product meets the requirements of the Efficiency Directive (92/42/EEC) for **condensing boilers**.

Allendorf, 2 April 2010

Viessmann Werke GmbH&Co KG



pp. Manfred Sommer

Certificates

Manufacturer's certificate according to the 1st BImSchV [Germany]

We, Viessmann Werke GmbH&Co KG, D-35107 Allendorf, confirm that the product **Vitodens 242-F** meets the NO_x limits specified by the 1st BImSchV paragraph 7 (2) [Germany].

Allendorf, 2 April 2010

Viessmann Werke GmbH&Co KG

A handwritten signature in black ink, appearing to read 'M. Sommer', with a long horizontal stroke extending to the right.

pp. Manfred Sommer

Keyword index

A

Acknowledging a fault display.....103
 Actuator test.....101
 Allocating heating circuits.....143

B

Boiler water temperature sensor.....117
 Boosting DHW heating.....129
 Brief scans.....99
 Burner gasket.....39
 Burner gauze assembly.....39
 Burner removal.....38

C

Calling up fault messages.....103
 Calling up the service level.....98
 Calling up the service menu.....98
 Changing the language.....27
 Checking functions.....101
 Checking the combustion quality.....50
 Cleaning the combustion chamber...40
 Cleaning the heat exchanger.....40
 Code 1
 ■ Calling up.....66
 Code 2
 ■ Calling up.....76
 Codes for commissioning.....51
 Combustion controller.....143
 Commissioning.....26
 Commissioning/service report.....159
 Condensate drain.....42
 Connection diagrams.....145
 Control unit maintenance position....114
 Cylinder cleaning.....46
 Cylinder temperature sensor.....117

D

Diaphragm expansion vessel.....26
 Draining the boiler
 ■ Heating water side.....115
 ■ On the DHW side.....45

E

Electronic combustion controller.....143
 Extension
 ■ AM1.....131
 ■ EA1.....133
 ■ Internal.....129, 130
 Extension kit for heating circuit with
 mixer125
 External blocking.....136
 External demand.....136

F

Fault codes.....104
 Fault history.....103
 Fault manager.....62
 Fault memory.....103
 Faults.....103
 Fill function.....137
 Filling the system.....26
 Fitting the burner.....40
 Flow temperature sensor.....117
 Flue gas temperature sensor.....121
 Function descriptions.....127
 Fuse.....124

G

Gas supply pressure.....35
 Gas train35
 Gas type.....31
 Gas type conversion.....32

H

Heating curve.....58
 Heating curve level.....60
 Heating curve slope.....60
 Heating program changeover.....135
 Heat-up time.....141
 Hiding a fault display.....103

I

Ignition.....40
 Ignition electrodes.....40
 Ionisation electrode.....40

Keyword index (cont.)

L

LON.....61

- Fault monitoring.....62
- Setting subscriber numbers.....61

LON communication module.....61

LON subscriber check.....62

M

Magnesium anode

- Checking the anode.....47
- Checking the anode connection....43
- Replacing the anode.....47
- Testing the anode current.....43

Manufacturer's certificate162

O

Outlet temperature sensor.....120

Outside temperature sensor.....116

P

Parts list.....149

Plate heat exchanger.....122

Protective anode

- Checking the anode.....47
- Checking the anode connection....43
- Replacing the anode.....47
- Testing the anode current.....43

R

Reduced room temperature.....61

Reduced room temperature raising. 140

Reducing the heat-up output.....140

Reducing the heat-up time.....141

Relay test.....101

Remote control.....143

Removing the front panels.....26

Reports.....159

Resetting codes.....66, 76

Room temperature adjustment.....60

Rotational direction of mixer motor

- Changing.....126
- Checking.....125

S

Safety chain123

Scanning operating conditions.....98

Scanning operating data.....98

Screed drying.....137

Screed drying function.....137

Setting the date.....28

Setting the output.....36

Setting the time.....28

Siphon.....42

Solar control module fuse.....125

Specification160

Standard room temperature.....60

Static pressure.....35

Supply pressure.....34

System pressure.....26

System schemes.....51, 66

System version.....52

T

Temperature limiter.....123

Tightness test, balanced flue system.37

V

Venting.....28

Venting program.....137

Vitocom 300.....61

Vitotronic 200-H.....61

Vitotronic 200-H.....126

W

Wiring diagram.....145





Applicability

Gas condensing/solar storage combi boiler

Type FB2B	from serial no.
4.8 to 19 kW	7438 015 ...
6.5 to 26 kW	7438 016 ...

Viessmann Werke GmbH&Co KG
D-35107 Allendorf
Telephone: +49 6452 70-0
Fax: +49 6452 70-2780
www.viessmann.com

Viessmann Limited
Hortonwood 30, Telford
Shropshire, TF1 7YP, GB
Telephone: +44 1952 675000
Fax: +44 1952 675040
E-mail: info-uk@viessmann.com

5412 755 GB Subject to technical modifications.