

Service instructions

for heating engineers

VIESSMANN

Vitoplus 300

Type VP3

12.9/19.3 kW, 16.1/23.5 kW

Oil fired wall mounted condensing boiler,
for use with low sulphur fuel oil EL to DIN 51603-1 or fuel oil EL
to DIN 51603-1 with a maximum sulphur content of 500 ppm
with integral boiler control unit

See notes on applicability, page 2.



VITOPUS 300



Safety instructions



Please follow these safety instructions closely to prevent accidents and material losses.

Work on the equipment

Installation, initial start-up, inspection, maintenance and repairs must only be carried out by a competent person (heating engineer/installation contractor).

Before working on the equipment/heating system, isolate the mains electrical supply (e.g. by removing a separate mains fuse or by means of a mains electrical isolator) and safeguard against unauthorised reconnection.

Repair work

It is not permitted to carry out repairs on parts that fulfil a safety function. Use only original Viessmann spare parts, or equivalent parts that have been approved by Viessmann.

Initial start-up

The initial start-up must be carried out by the system installer or a designated commissioning engineer. All actual values should be recorded in a commissioning/service report.

Instructing the system user

The system installer must hand the operating instructions to the system user and instruct him/her in the operation of the system.

Safety instruction

In this instruction manual, this heading denotes information which must be observed to prevent accidents and material losses.

Applicability

from serial no.

7158049 1 00001 

7174019 2 00001 

Index

	Page
General information	
Safety instructions	2
Applicability	2
Initial start-up, inspection and maintenance	
Steps – initial start-up, inspection and maintenance	4
Further details regarding the individual steps	6
Troubleshooting	
Burner diagnostics	26
Control unit diagnostics	34
Repairs	44
Strapping plug configuration and coding	53
Control with standard programming unit	
Function description	57
Calling up coding level 1	59
Heating curves	60
Adjusting heating curves	61
Coding level 1 overview	64
Calling up coding level 2	69
Coding level 2 overview	70
Brief scan	74
Scanning temperatures	75
Control with Comfortrol programming unit	
Function description	77
Calling up coding addresses	79
Heating curves	80
Adjusting heating curves	81
Summary of coding addresses	82
Brief scan	92
Scanning temperatures	93
Connection and wiring diagrams	
■ Internal assemblies	94
■ Main PCB VGL 10	97
Parts lists	100
Appendix	
Commissioning/service report	108
Specification	114
Declaration of conformity	115
Manufacturer's certificate	116
Keyword index	117

Steps – initial start-up, inspection and maintenance

For further instructions on individual steps, see pages indicated.

			Page
		Commissioning steps	
		Annual inspection steps	
		Maintenance steps	
C		1. Filling heating system	6
C		2. Checking electrical mains connection	
C		3. Changing language (if necessary)	7
C		4. Boiler start-up	
C	M	5. Adjustments; standard values for burner adjustment	8
C	M	6. Selection burner stage 1 and 2	9
C	M	7. Oil pressure adjustment and vacuum check	10
C	M	8. Adjusting air volume (static burner pressure)	11
C	M	9. Checking burner (recording values on page 108 of commissioning/service report)	
	I	10. Checking and cleaning the flame monitor	12
	M	11. Cleaning burner	13
	M	12. Replacing nozzle and checking/adjusting ignition electrodes	14
	M	13. Cleaning and, if required, replacing oil pump filter	16
	M	14. Replacing filter element of pre-filter (filter grade max. 40 μm)	
	I	15. Checking combustion chamber for contamination	17
	I	16. Cleaning combustion chamber	18
	I	17. Cleaning siphon and checking condensate drain	20
	I	18. Checking neutralising system	20
	I	19. Installing burner (tightening nuts diagonally, max. 5 Nm)	
C	M	20. Checking diaphragm expansion vessel and system pressure	21
C	M	21. Checking function of all safety valves	

Steps – initial start-up, inspection and maintenance (cont.)

	Commissioning steps	Annual inspection steps	Maintenance steps	Page
C				
			M	22. Checking all heating water connections for leaks
			M	23. Checking tightness of electrical connections
			M	24. System start-up
			M	25. Checking oil supply pipes and connections for leaks
			M	26. Checking burner again and entering actual values in commissioning report
C				27. Matching coding addresses to heating system 22

Further details regarding the individual steps

Filling heating system

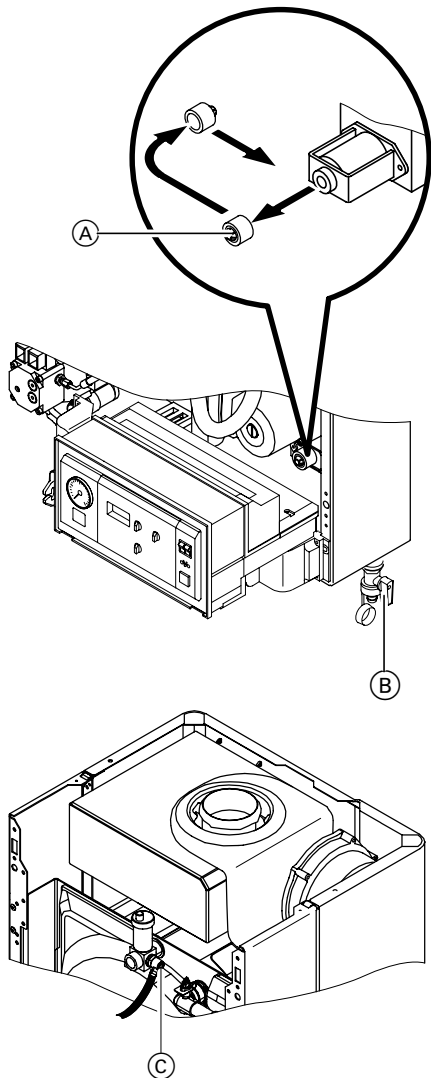

1. Check the charge pressure of the diaphragm expansion vessel (see page 21).
2. Remove protective cap (A) from the diverter valve, and replace the opposite way around (central position of the valve for improved ventilation).
3. Fill the system via tap (B), vent the system and check the system pressure (min. system pressure > 0.8 bar).
4. Reposition protective cap (A).
5. Close the shut-off valves on the heating water side.
6. Connect the drain hose to upper ball valve (C).
7. Open ball valves (B) and (C), and vent at mains pressure until no further air noises are audible.
8. Close ball valves (B) and (C), and open the shut-off valves on the heating water side.

Further details regarding the individual steps (cont.)

Changing language (if necessary) – only for control units with menu-guided Comfortrol programming unit

SPRACHE/LANGUAGE
>DEUTSCH:.....A
>FRANCAIS:.....B
>ZURÜCK/BACK:.....D

Open flap:
Menu item Key
→ SYSTEM **D**
→ BASIC SETTINGS **A**
→ LANGUAGE **C**
Select required language.

Further details regarding the individual steps (cont.)

Adjustments; standard values for burner adjustment

Standard values for burner settings

Note

Check that the service instructions are valid for the burner concerned (see applicability on page 2 and serial no. on the boiler type plate).

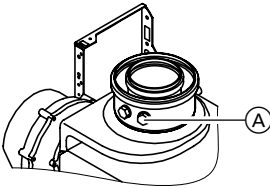



Ⓐ Flue gas test port

Rated output	kW	12.9/19.3		16.1/23.5	
Burner stage		Stage 1	Stage 2	Stage 1	Stage 2
Rated output at burner stage	kW	12.9	19.3	16.1	23.5
Oil burner nozzle Make: Danfoss	Type Gph	80°H LE 0.40		80°H LE 0.50	
Oil pressure approx. *1	bar	8.0-10.5	15.0-17.5	8.0-11.0	13.5-16.0
Max. permiss. vacuum in the oil supply line	bar	0.35	0.35	0.35	0.35
Oil flow rate approx.	kg/h l/h	1.05 1.24	1.58 1.86	1.31 1.57	1.92 2.30
Static burner pressure approx.					
– Operating phase	mbar	8.0-9.5	16.0-17.5	8.7-9.7	17.5-19.5
– Ignition phase	mbar	11	11	11	11
CO₂ content approx.	%	12.7-13.7		12.7-13.7	
Nozzle gap Dim. a in illustration on page 14. Always maintain this adjustment or check against details on page 15.	mm	3.5 ^{+0.2} _{-0.3}		2.0 ^{+0.2} _{-0.3}	

*1The oil pressure may vary from that indicated by the values shown, due to nozzle tolerances and varying oil characteristics.

Further details regarding the individual steps (cont.)

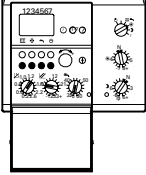
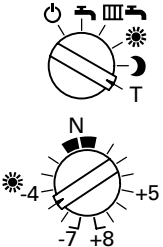
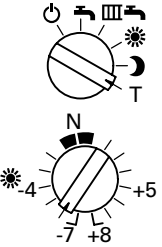
Selection burner stage 1 and 2

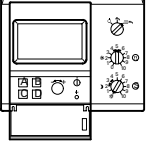
Steps	Burner stage 1	Burner stage 2	Terminate setting mode
<p>Control unit type</p> <p>Control with standard programming unit</p> 			<ul style="list-style-type: none"> ■ Set required operating program. ■ Set rotary selector  to required value.
<p>Control unit with menu-guided Comfortrol programming unit</p> 	<p>→ SYSTEM D</p> <p>→ INSTALLER SETUP C</p> <p>→ CODE PLS B-C-C-B</p> <p>→ DIAGNOSIS A</p> <p>→ RELAY TEST A</p> <p>With menu item CONTINUE A</p> <p>up to code 10: MODULATION</p> <p><ST.90> CLOSED BURNER</p> <p><ST.41> ON</p>	<p>With menu item CONTINUE A</p> <p>up to code 11: MODULATION</p> <p><ST.90> OPEN BURNER</p> <p><ST.41> ON</p>	<ul style="list-style-type: none"> ■ Close programming unit.

Further details regarding the individual steps (cont.)

Oil pressure adjustment and vacuum check

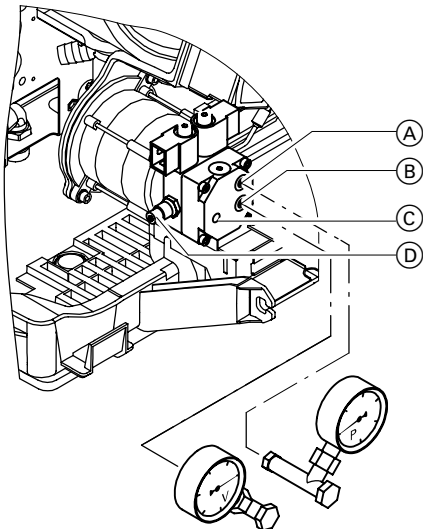

Danfoss oil pump, type BFP 52

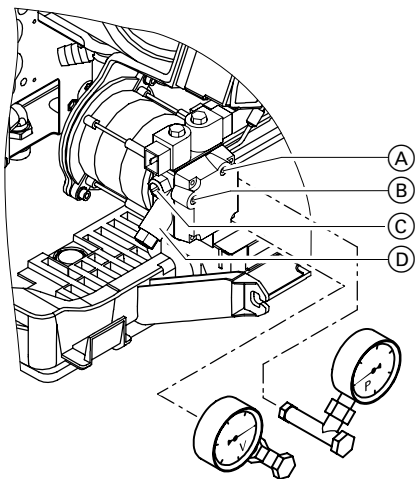

Suntec oil pump, type ATE 2

1. Insert a pressure gauge (range 0-25 bar) into test port P (A) and a vacuum meter (range 0-1 bar) into test port V (B).

Seal the pressure and vacuum gauges only with copper or aluminium gaskets or O-rings. Never use sealing tape.

2. Start the burner and select burner stage 1 (see table on page 9).
3. Where the vacuum measures higher than 0.35 bar, check the filter for contamination or the pipe routing.
4. If necessary, adjust the oil pressure at the pressure adjusting screw for stage 1 (C) of the oil pump (standard value see page 8).
5. Check the actual emission values after adjusting the oil pressure.
6. Select burner stage 2 (see table on page 9).
7. If necessary, adjust the oil pressure at the pressure adjusting screw for stage 2 (D) of the oil pump.
8. Check the actual emission values after adjusting the oil pressure.

Further details regarding the individual steps (cont.)

Adjusting the air volume (static burner pressure)

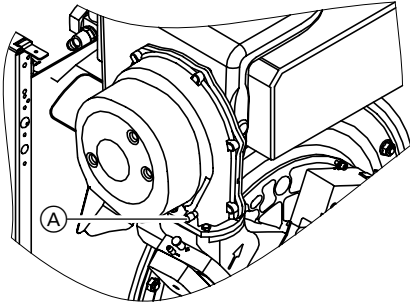

1. Start up boiler.
2. Connect the U-shaped pressure gauge to test nipple (A).
3. Release the bottom part of control unit (B) and pivot down.
4. Unscrew protective cover (C) and rear casing lid (D).
5. Select the respective burner stage (see table on page 9) and adjust the air volume at the corresponding potentiometer (E) and (F) (standard values for static burner pressure see page 8).

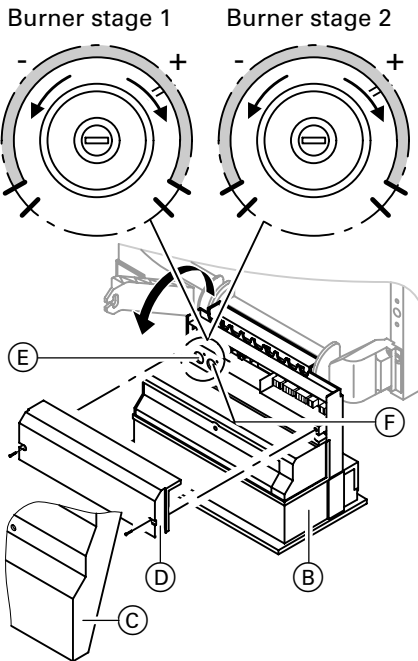

Note

Do not exceed the setting range.

= setting range

Further details regarding the individual steps (cont.)

Checking and cleaning the flame monitor

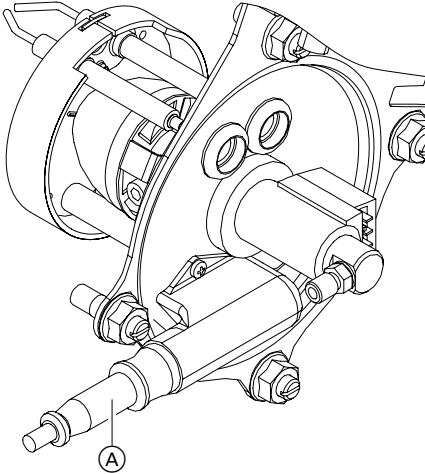

1. Pull flame monitor (A) out of its holder for checking and cleaning.

2. Check the function:

	Checks to be carried out	Required response
1.	Start up the burner with the flame monitor covered up	Fault shutdown at the end of safety period TSA
2.	Start up the burner and shine a light onto the flame monitor	Fault shutdown after max. 40 s
3.	Burner operation with simulated flame blow-off. For this, cover up the flame monitor during operation and leave in that state.	Restart followed by fault shutdown at the end of safety period TSA

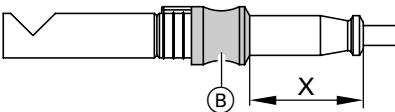

3. Push slide sleeve (B) of flame monitor (A) forward against its endstop (x = max.) and install the flame monitor.

Note

Position the guide web into the retaining slot.

Further details regarding the individual steps (cont.)

Cleaning the burner

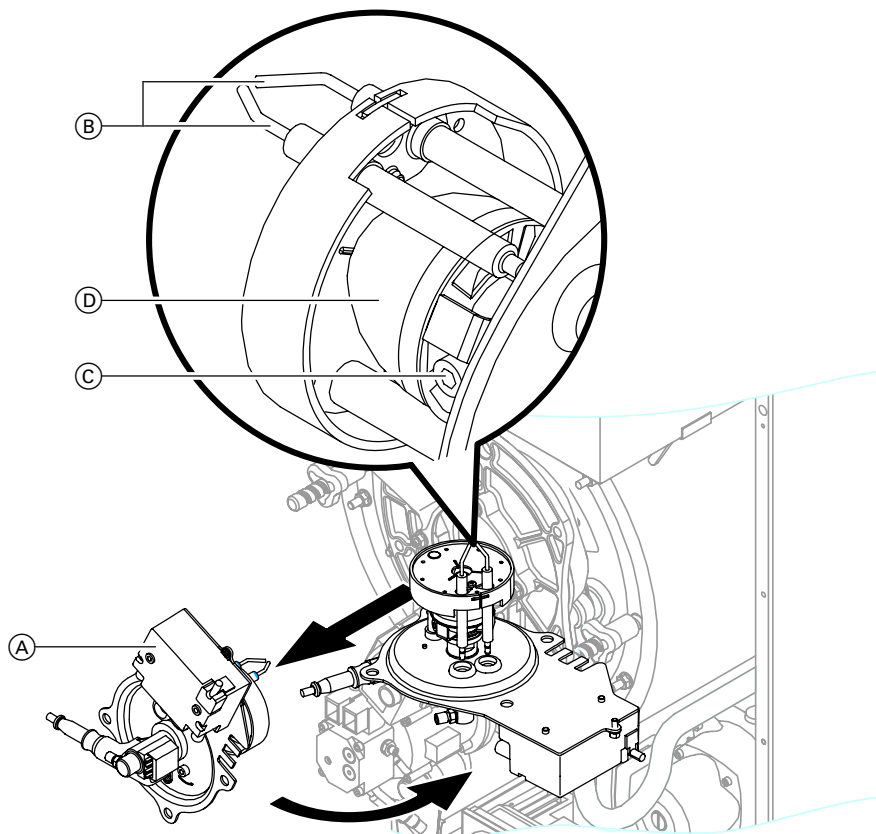

1. Release the nuts, remove the cover together with mixing equipment (A) and plug into the maintenance position.
2. Pull off ignition electrodes (B).
3. Release Allen screw (C) and remove swirl equipment (D).
4. Clean the restrictor, the metering ring, the ignition electrodes and the flame monitor tube.

Further details regarding the individual steps (cont.)

Replacing nozzle and checking or adjusting ignition electrodes

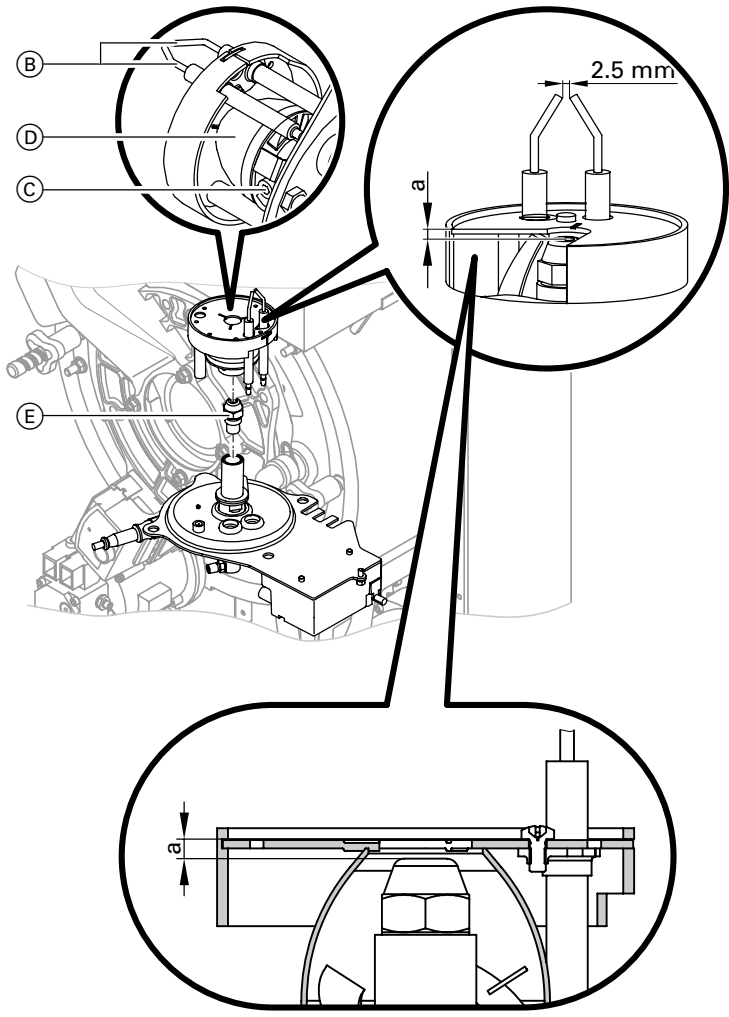

Further details regarding the individual steps (cont.)

1. Unscrew nozzle ⑤ (whilst holding the oil pre-heater). Prevent the formation of air locks.
2. Insert a new LE nozzle ⑤ (whilst holding the oil pre-heater).
3. Plug in swirl equipment ④ until it bottoms out.
Align ignition electrodes ⑥ in accordance with the holes towards the cable gland. The oil burner nozzle must always be installed in the centre of the restrictor.
4. Tighten Allen screw ③ of the swirl equipment.
Check nozzle gap a.

Warning:

An incorrect nozzle gap a can lead to a pulsating burner operation and eventual burner fault shutdown.

Rated output	kW	12.9/19.3	16.1/23.5
Nozzle gap a	mm	$3.5^{+0.2}_{-0.3}$	$2.0^{+0.2}_{-0.3}$

Further details regarding the individual steps (cont.)

Cleaning and, if required, replacing the oil pump filter

Danfoss oil pump, type BFP 52

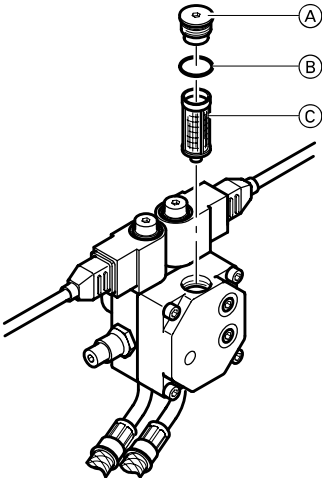

- Ⓐ Filter plug
- Ⓑ O-ring (replace)
- Ⓒ Filter (replace)

Suntec oil pump, type ATE 2

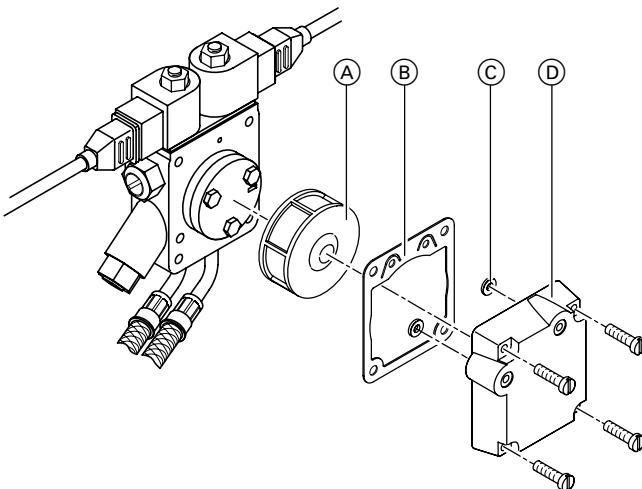

- Ⓐ Filter (clean or replace)
- Ⓑ Flat gasket (replace)
- Ⓒ O-ring (replace)
- Ⓓ Lid

Further details regarding the individual steps (cont.)

Checking the combustion chamber for contamination

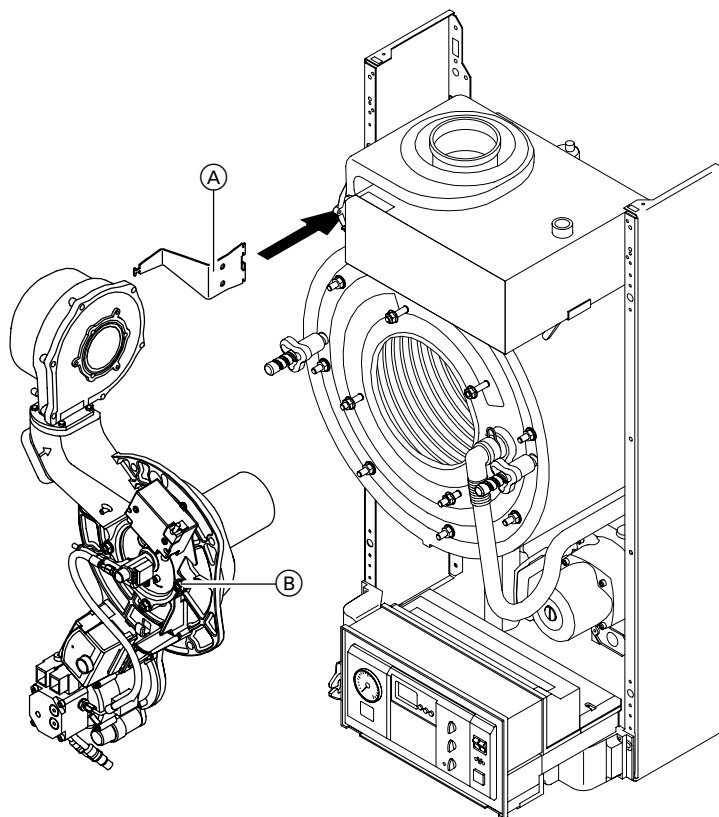

1. Pull the 7-pole and the 3-pole plug off the burner control unit and plug 100A on the fan motor.
2. Plug burner holder (A) (part of the cleaning set) on the r.h. or l.h. side into the boiler.
3. Release the four fixing screws on burner (B) and remove the burner.
4. Hook burner (B) into burner holder (A) or support it on a suitable base.
5. Check the heat exchanger for contamination. If contaminated, continue on page 18).

Further details regarding the individual steps (cont.)

Cleaning the combustion chamber

Note

Only clean with the cleaning equipment available as accessory.

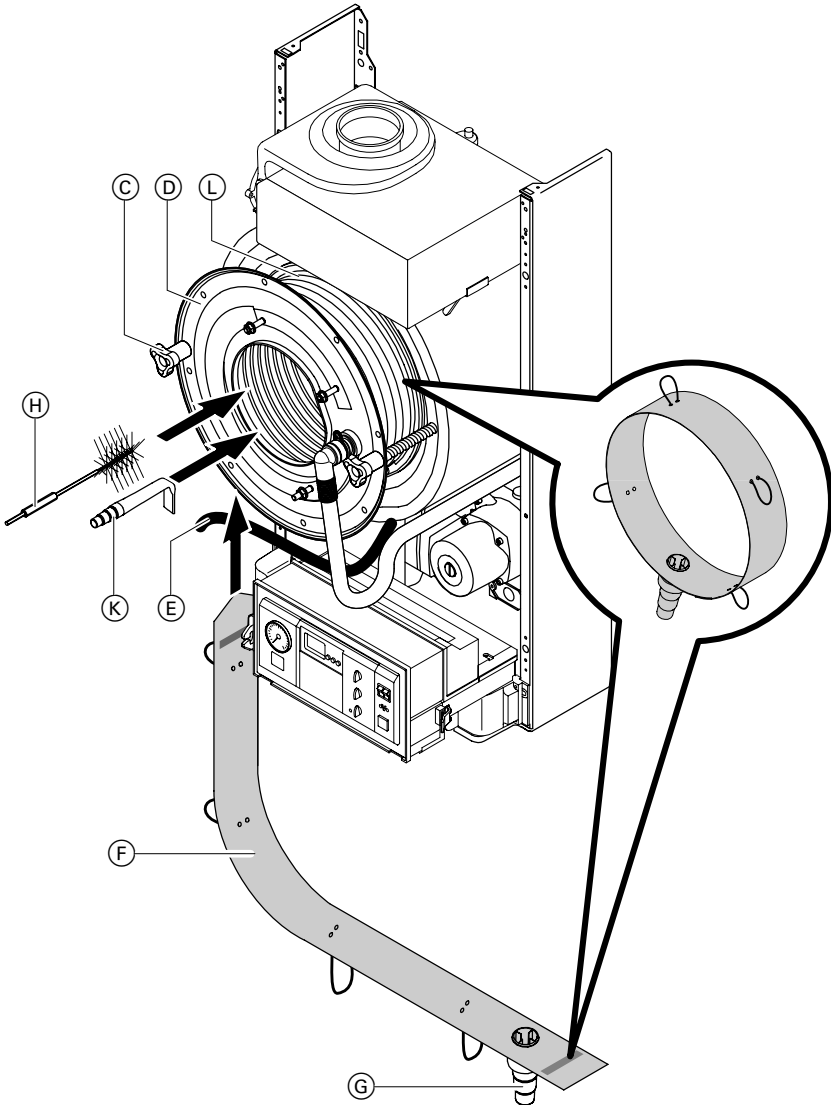

Further details regarding the individual steps (cont.)

1. Turn handles (C) by hand towards heat exchanger (D).
2. Release the eight fixing screws of heat exchanger (D).
- Note**
Cover up the control unit.
3. Evenly release handles (C) to their endstop.
4. Pull condensate drain hose (E) off the neutralising system and route it into a container.
5. Insert a dirt trap (F) (accessory) between the boiler body and the front panel of the heat exchanger.
6. Align dirt trap (F) with the outlet for the vacuum cleaner towards the left, and hook with the holding loop over the threaded stud.
7. Connect a vacuum cleaner to connector (G), and start the vacuum cleaner.
8. Fit rotary brush (H) (accessory) to a rechargeable or mains power drill, and clean the heat exchanger (at a low speed). Remove any deposits until the coil sides are clean.
9. Before switching off the vacuum cleaner, lightly knock dirt trap (F), to ensure that the dirt is removed as completely as possible.
10. Remove dirt with the vacuum cleaner and an angled nozzle (K) (accessory) through the gaps in the heat exchanger.
11. Carefully remove dirt trap (F).
12. Clean gasket (L) and sealing faces on the front panel of the heat exchanger.
13. Close heat exchanger (D) by evenly turning handles (C), until the nuts can be refitted again.
14. Evenly tighten the nuts diagonally.
15. Flush the combustion chamber thoroughly with water. Ensure that the drain hose is still routed into the container (see item 4).

Safety instruction

For this, wear safety goggles.

Further details regarding the individual steps (cont.)

Cleaning the siphon and checking the condensate drain

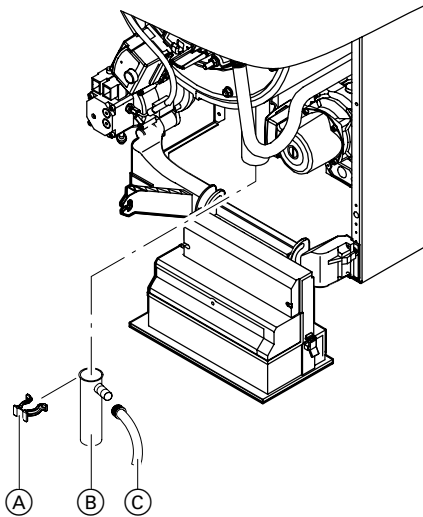

- Ⓐ Retaining clip
- Ⓑ Siphon (clean and then fill with water)
- Ⓒ Drain hose

Checking the neutralising system (accessory)

Check the pH value of the condensate with a pH test strip. Replace the granulate if the pH value reaches < 6.5 .

→ **Note**

Part no. for pH test strips: 9517 678.

Observe the manufacturer's instructions regarding the neutralising system.

Further details regarding the individual steps (cont.)

Checking the diaphragm expansion vessel and the system pressure

Carry out this test on a cold system.

1. Drain the boiler or the system and reduce the pressure until the pressure gauge shows 0.
2. If the inlet pressure of the diaphragm expansion vessel is lower than the static system pressure, top up with sufficient nitrogen to raise the charge pressure higher than the static system pressure.

Example

*Static ceiling 10 m
(distance between boiler and
highest heating surface)
equals static pressure 1 bar*

3. Top up water, until the filling pressure exceeds the charge pressure of the diaphragm expansion vessel.

*On a cold system, the filling pressure should be approx. 0.2 bar higher than the static pressure.
Max. operating pressure 3 bar.
Min. operating pressure 0.8 bar.*

4. During the initial start-up, mark this value on the pressure gauge as minimum filling value.

Further details regarding the individual steps (cont.)

Matching coding addresses to the heating system

The control unit must be matched to the system equipment.

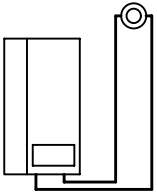
	Control with standard programming unit	Control with Comfortrol programming unit
<p>As delivered condition</p> 	<p>Design 04:00 Heating system with one heating circuit without mixer, without DHW heating.</p>	<p>Design 000:000</p>

Adjusting the heating system design

- *For selection of an appropriate design, see the following diagram.*
- *Coding steps*
 - *with standard programming unit, see page 59,*
 - *with Comfortrol programming unit, see page 79.*

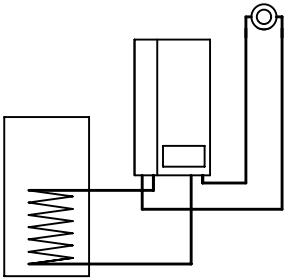
	<p>Design 04:01 Heating system with one heating circuit without mixer, with DHW heating.</p> <p><i>The code is automatically adjusted during cylinder sensor connection when operating with a DHW cylinder.</i></p>	<p>Design 000:001</p>
--	--	------------------------------

Further details regarding the individual steps (cont.)

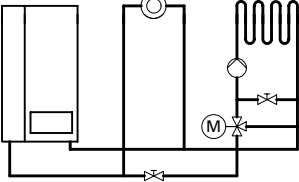
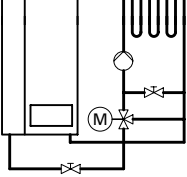
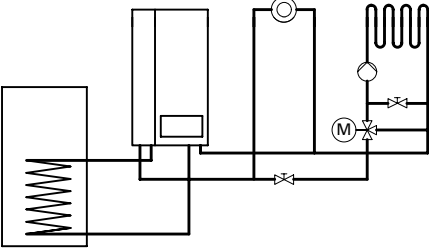
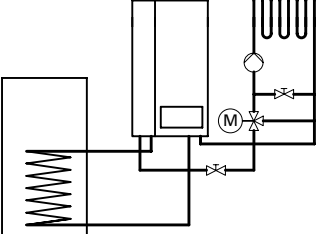
	Control with standard programming unit	Control with Comfortrol programming unit
	<p>Design 04:02</p> <p>Heating system with one heating circuit with mixer and one heating circuit without mixer, without DHW heating.</p>	<p>Design 000:002</p>
	<p>Design 04:02</p> <p>Heating system with one heating circuit with mixer, without DHW heating.</p> <p><i>Set coding addresses 044, 045 and 046 respectively to 001.</i></p>	<p>Design 000:002</p>
	<p>Design 04:03</p> <p>Heating system with one heating circuit with mixer and one heating circuit without mixer, with DHW heating.</p>	<p>Design 000:003</p>
	<p>Design 04:03</p> <p>Heating system with one heating circuit with mixer, with DHW heating.</p> <p><i>Set coding addresses 044, 045 and 046 respectively to 001.</i></p>	<p>Design 000:003</p>

Further details regarding the individual steps (cont.)

Heating system designs with low loss header

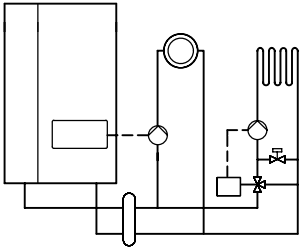
	Control with standard programming unit	Control with Comfortrol programming unit
	<p>Design 04:02 Heating system with</p> <ul style="list-style-type: none"> ■ low loss header (with additional flow temperature sensor) ■ one heating circuit with mixer ■ one heating circuit without mixer (controlling heating circuit pump via connection extension adaptor) ■ without DHW heating. <p>Adjustment Set the heating circuit pump switching times at time switch channel III (heating circuit A). Set coding address 03 to 00.</p> <p>Note The integral circulation pump acts as boiler circuit pump and runs always when one of the other pumps is active. A DHW circulation pump cannot be controlled.</p>	<p>Design 000:002</p> <p>Set the heating circuit pump switching times at heating circuit A time switch channel. Set coding address 0B8 to 000.</p>

Further details regarding the individual steps (cont.)

Heating system designs with low loss header (cont.)

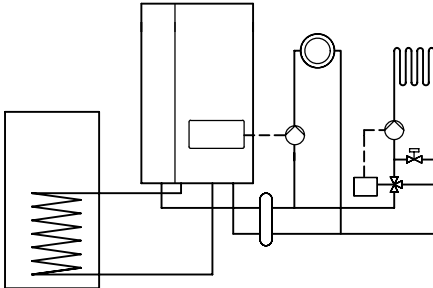
	Control with standard programming unit	Control with Comfortrol programming unit
	<p>Design 04:03</p> <p>Heating system with</p> <ul style="list-style-type: none"> ■ low loss header (with additional flow temperature sensor) ■ one heating circuit with mixer ■ one heating circuit without mixer (controlling heating circuit pump via connection extension adaptor) ■ with DHW heating. <p>Adjustment</p> <p>Set the heating circuit pump switching times at time switch channel III (heating circuit A). <i>Set coding address 03 either to 01 or 02.</i></p> <p>Note</p> <p><i>The integral circulation pump acts as boiler circuit pump and runs always when one of the other pumps is active. A DHW circulation pump cannot be controlled.</i></p>	<p>Design 000:003</p> <p>Set the heating circuit pump switching times at heating circuit A time switch channel. <i>Set coding address 0B8 to 001 or 002.</i></p>

For further adjustments, see coding summary

- *with standard programming unit, from page 64,*
- *with Comfortrol programming unit from page 82.*

Burner diagnostics

Program sequence - burner control unit LMO 54.220 ...

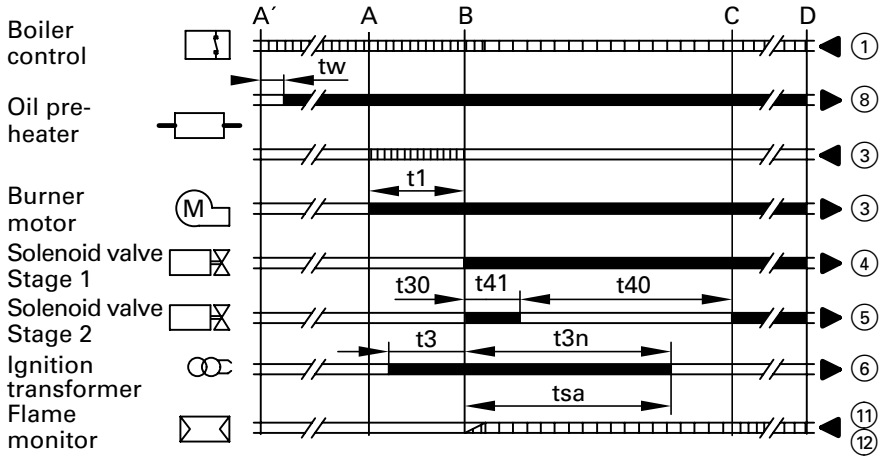

Legend

- t1 Purge time, 16 s.
- t3 Pre-ignition time, 15 s.
- t3n Post-ignition time, 10 s.
- t30 Ignition delay between solenoid valve enable stage 1 and solenoid valve stage 2, 0.3 s.
- t40 Start-up delay solenoid valve stage 2, 18 s.
- t41 Start-up delay solenoid valve stage 2, 1 s.
- t_{sa} Safety time, start-up, 10 s.
- tw Dwell time, oil pre-heater
- ①-⑫ Contact allocation, plug-in panel

Function displays on the burner control unit (reset button)

Operating condition	Colour
Oil pre-heater is heating, dwell time tw	constant yellow light
Ignition phase, ignition activated	yellow flashing
Operation, flame steady	constant green light
Operation, poor flame	green flashing
Undervoltage	alternating yellow-red
Fault, burner locked out	constant red light
Fault display (for explanations see 29)	red flashing
Extraneous light before burner start	alternating green-red
Fault display still active (see page 27)	red flickering light

Burner diagnostics (cont.)

Function displays on the burner control unit (reset button)

In standard mode, operating states are displayed by colour code inside the reset button.

After a fault shutdown, the lamp inside the reset button illuminates constantly red. In this state, the optical cause display may be activated (see flow chart on page 28).

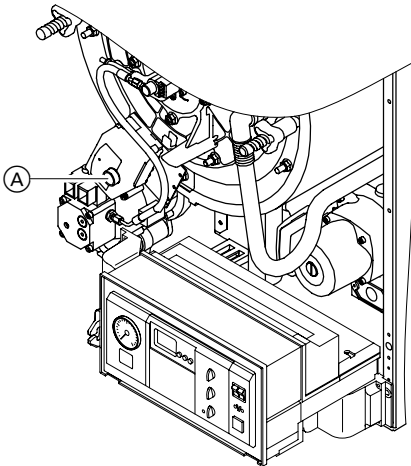

1. Press reset until the lamp briefly illuminates red and yellow.

Note

If the lamp flickers red, press reset again until it no longer flickers.

2. Then a flashing code appears. The number of signal flashes in one sequence indicates the type of fault. For explanations, see the table on page 29.

Note

When faults are displayed, all control outputs are at zero volt, and the burner remains OFF. Terminal B4 on plug 132 has a potential of 230 V~.

3. To reset the burner and exit the fault display, press reset for approx. 1 s. (less than 3 s.).

Burner diagnostics (cont.)

Burner fault flow chart

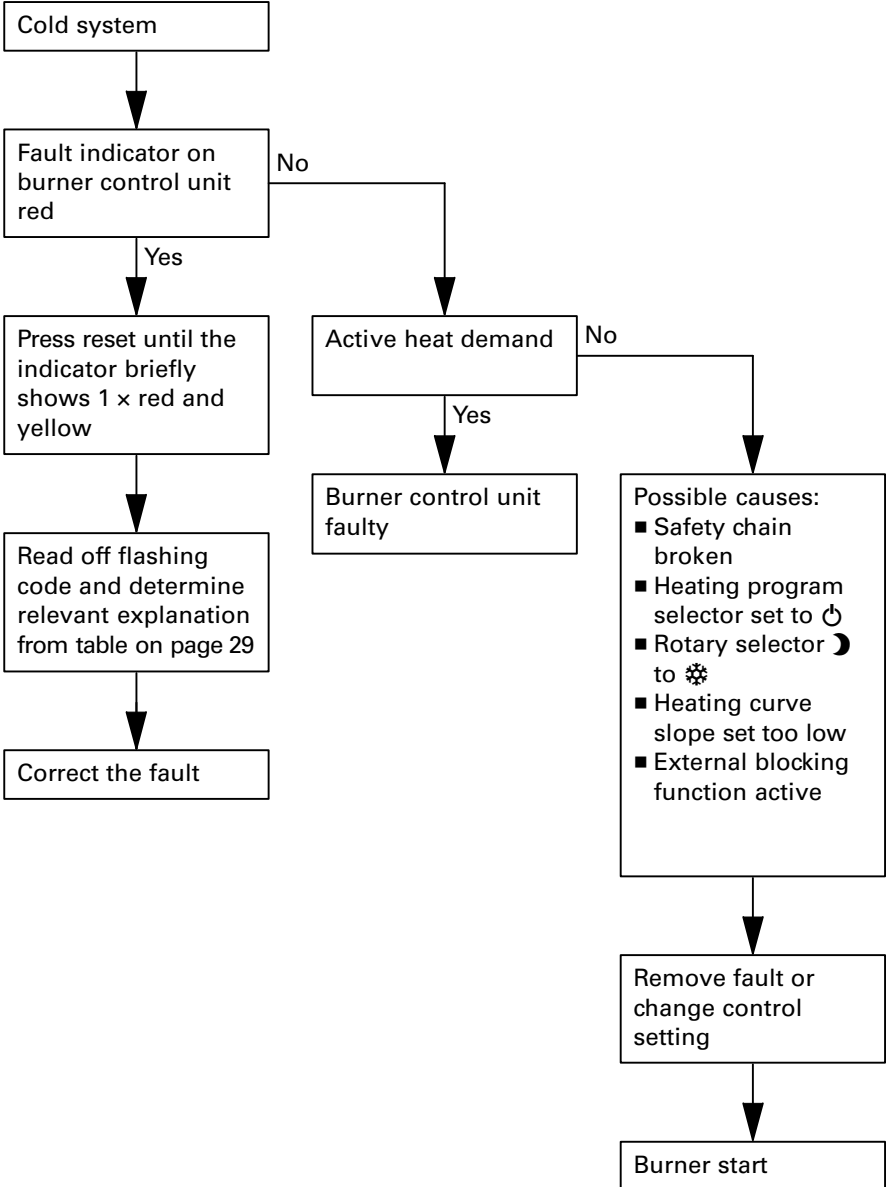

Burner diagnostics (cont.)

Fault code table

Flashing codes not listed here have no particular meaning.

Flashing code	Explanation
2 × flashing ■ ■	No flame established at the end of safety period TSA – Fuel valves faulty or contaminated – Flame monitor faulty or contaminated – Poor burner setting – No fuel – Ignition equipment faulty
4 × flashing ■ ■ ■ ■	External light during burner start
7 × flashing ■ ■ ■ ■ ■ ■ ■	Flame fails too frequently during operation – Fuel valves faulty or contaminated – Flame monitor faulty or contaminated – Poor burner setting
8 × flashing ■ ■ ■ ■ ■ ■ ■ ■	Faulty oil pre-heater (required temperature not achieved)
10 × flashing ■ ■ ■ ■ ■ ■ ■ ■ ■ ■	Wiring fault (power supply phases interchanged) or internal error, connection contacts, not an immediate error, e.g. more than one fault occurring at once

Burner diagnostics (cont.)

Fault display on the burner control unit and fault codes, see page 27 and 29.

Fault/system characteristics	Flashing code	Cause	Remedy
Burner does not start (without fault display)		No voltage	Check fuse in control unit, check electrical connections, check position of ON/OFF switch on control unit and power supply voltage
		High limit safety cut-out activated	Press reset (see page 48)
Burner does not start (with fault display)	2 x	Motor faulty	Replace motor
	4 x	Flame monitor received external light	Eliminate external light ingress
Burner starts, but no flame is formed	2 x	Ignition electrodes poorly adjusted	Adjust correctly (see page 14)
	2 x	Ignition electrode damp and contaminated	Clean ignition electrode block
	2 x	Insulation of ignition electrode cracked	Replace ignition electrode block
	2 x	Ignition transformer faulty	Replace ignition transformer
	2 x	Ignition cable faulty	Replace ignition cable
	2 x	Nozzle faulty	Replace nozzle (see page 14)
	2 x	Pump does not supply oil	Install pressure and vacuum gauges on pump, and check pressure build-up (see following paragraph)

Burner diagnostics (cont.)

Fault/system characteristics	Flashing code	Cause	Remedy
Pump does not supply oil	2 x	Shut-off valves closed at filter or in oil pipe	Open valves
	2 x	Filter blocked	Clean filter (pre-filter and pump filter)
	2 x	Leak in suction line or filter cup	Tighten connections. Check oil pipes and connections for leaks and tighten, if necessary.
	2 x	Oil flow and return hoses interchanged	Connect correctly acc. to instructions on pump
	2 x	Vacuum in suction line too high (higher than 0.35 bar)	Check cross-section of oil supply pipe. Replace filter.
Burner starts, but no oil is injected; pressure gauge on pump indicates zero pressure	2 x	Oil pump faulty	Replace oil pump
	2 x	Suction line faulty or plugged	Check suction pipe
Burner starts, but no oil is injected; pressure gauge on pump indicates pressure	2 x	Nozzle blocked	Replace nozzle
	2 x	Solenoid valve does not open	Replace coil of solenoid valve
	4 x	Flame monitor faulty	Replace flame monitor
Burner starts and flame is formed, but burner cuts out after safety time expires	2 x	Flame monitor contaminated	Clean flame monitor
	2 x	Flame monitor faulty	Replace flame monitor

Burner diagnostics (cont.)

Fault/system characteristics	Flashing code	Cause	Remedy
Flame blows off during start or operation	2 x	Air in suction line	Seal line and filter
	2 x	Nozzle faulty	Replace nozzle
	2 x	Pump pressure incorrectly adjusted	Correct the oil pressure. For standard values for burner adjustment, see page 8.
	2 x	Flue gas recirculation too high	Reduce the recirculation gap via the setting screw. Turn screw (A) ½ turn at a time towards –
Operation interrupted by flame blow-off; burner restarts	7 x	Flame monitor contaminated	Clean flame monitor
	7 x	Flame monitor retaining tube contaminated	Clean retaining tube
	7 x	Nozzle faulty	Nozzle replacement

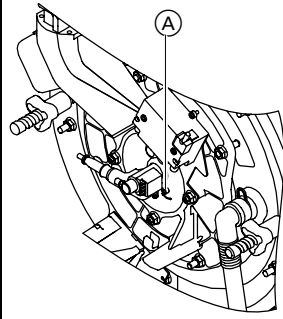

Burner diagnostics (cont.)

Fault/system characteristics	Cause	Remedy
CO ₂ content too high	Lack of air	Check oil pressure setting and correct, if required. Check combustion air pipe.
	Flue gas route blocked	Check flue gas route
	Nozzle faulty	Replace nozzle and install correct nozzle (see page 14)
CO ₂ content too low	Incorrect setting	Check setting (see page 8)
	Infiltrating air	Retighten fixing screws on burner lid. Check the soundness of the mixing equipment and the burner lid.
	Nozzle faulty	Replace nozzle
Flue gas temperature too high	Boiler contaminated	Clean boiler and correct burner settings
	Oil consumption too high	Correct the oil pressure. For standard values for burner adjustment, see page 8.

Control unit diagnostics

Control with standard programming unit

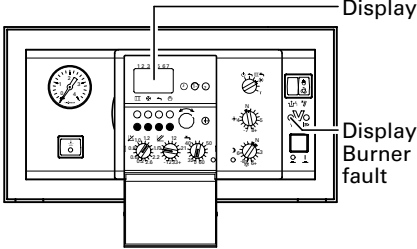

Control with Comfortrol programming unit

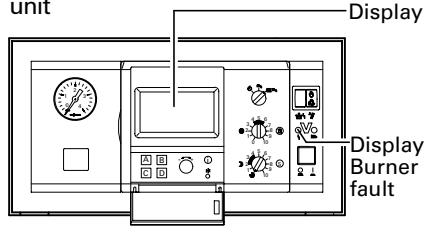

Open flap → Fault scan A

Diagnostics table: Faults with fault display on control unit

Fault message display		Display Burner fault, red	System characteristics
Control with standard programming unit	Comfortrol programming unit		
—	—	—	Boiler does not start
↳:1: 0	FAULT: OUTSIDE TEMP. SENSOR	OFF	Activates after 0 °C outside temperature
↳:1: 8			
↳:1: 1	FAULT: 11	OFF	Boiler cools down
↳:3: 0	FAULT: BOILER TEMP. SENSOR	OFF	Boiler runs with a high boiler water temperature
↳:3: 8			
↳:4: 0	FAULT: FLOW TEMP. SENSOR	OFF	Mixer opens
↳:4: 8			Mixer closes
↳:5: 0	FAULT: CYLINDER TEMP. SENSOR	OFF	DHW cylinder cools down
↳:5: 8			



Cause	Remedy
—	Check the function sequence (see burner diagnostics on page 30).
Outside temperature sensor short circuit or cable break	Check outside temperature sensor (see page 44)
Air volume regulator potentiometer turned outside its setting range or faulty	Correct the potentiometer adjustment (see page 11) or replace
Boiler temperature sensor short circuit or cable break	Check boiler temperature sensor (see page 45)
Flow temperature sensor short circuit or cable break	 Mixer motor installation instructions
Cylinder temperature sensor short circuit or cable break	Check cylinder temperature sensor (see page 45)



Diagnostics using control unit (cont.)

Fault message display Control with standard pro- gramming unit		Comfortrol pro- gramming unit	Display Burner fault, red	System characteristics
l:6: 0	—		OFF	Boiler cools down
l:6: 8				
l:6: 1	—		OFF/ON	Boiler cools down
l:6: 9				
l:7: 0	FAULT: 70		OFF	Activation after 20 °C day set value, 14 °C night set value
l:7: 8	FAULT: 78		OFF	Activation after 20 °C day set value, 14 °C night set value
l:A: 1	FAULT: A1		Flashing	Boiler operates in emergency mode (after 30 minutes BUS fault)
			OFF	Boiler cools down
l:A: 2	FAULT: A2		OFF	—
l:A: 4	FAULT: A4		OFF	Pump runs at max. speed or pump inoperative
l:A: 5	FAULT: A5		OFF	—

Cause	Remedy
Incorrect coding for code address 27 (standard programming unit)	Set coding address 27 to 0
Incorrect coding for code address 31 (standard programming unit)	Set coding address 31 to 0
WS/RS remote control unit short circuit	Check WS/RS remote control unit
WS/RS remote control unit cable break or incorrect coding	Check WS/RS remote control unit. Check coding.
BUS fault	Check seating of VR 20 circuit board. Check BUS connections at plug X5.3-X5.4 (e.g. extension kit for heating circuit with mixer or Vitocom) for correct connection and function (if necessary, disconnect wires for troubleshooting). Check variable speed heating circuit pump and its connecting cables.
Internal BUS connection break	
KM BUS fault to Vitocom	Check connections or Vitocom
BUS connection to variable speed heating circuit pump interrupted or faulty pump	Check the cable connections to the heating circuit pump or check heating circuit pump
Short circuit/break in BUS connection to extension kit for heating circuit with mixer	Check the cable connection to the extension kit (plug X5). Check coding acc. to heating system design. Check correct connection via Brief scan – Control with standard programming unit, see page 74. – Control with Comfortrol programming unit, see page 92.

Diagnostics using control unit (cont.)

Fault message display Control with standard pro- gramming unit	Comfortrol pro- gramming unit	Display Burner fault, red	System characteristics
—	FAULT: B1	OFF	Constant heating
I:b: 2	FAULT: B2	OFF	Boiler cools down
I:C: C	FAULT: CC	ON	Main circuit board VGL 10 in fault state
I:E: 4 or I:E: __	FAULT: E4	OFF	—
I:F: 2	FAULT: F2	OFF	—
I:F: 4	FAULT: F4	OFF	—
I:F: 5	FAULT: F5	OFF	—
I:F: 9	FAULT: F9	OFF/ON	Main circuit board VGL 10 in fault state
I:F: B	FAULT: FB	OFF	Emergency mode, main circuit board VGL 10
I:F: E	FAULT: FE	ON	Main circuit board VGL 10 in fault state
I:O: 2	FAULT: O2	OFF	Boiler cools down
I:O: 4	FAULT: O4	ON	Main circuit board VGL 10 in fault state

Cause	Remedy
Break in the BUS connection to the Comfortrol programming unit	Check the cable connections to the programming unit
Internal control unit fault	Replace control unit
—	First create another fault, then press reset  once. Replace the main PCB VGL 10 if the fault persists.
Fault at connected Vitotronic 050 heating circuit controller	Check Vitotronic 050 heating circuit control unit and BUS connection at plug X5 (see page 50)
Vitocom error	Check Vitocom
Fault message – variable speed heating circuit pump	Check variable speed heating circuit pump
Fault message, extension kit for one heating circuit with mixer	Check extension kit and its coding
Incorrect operation in conjunction with Vitosoft	Press reset key  once
KM BUS fault	Check adapter PCB and interconnections; replace main PCB VGL 10, if required
—	Press reset  once. If this fault message persists after the reset, replace the PCB VGL 10.
High limit safety cut-out activated	Reset high limit safety cut-out (see p. 48). Vent whole system and check heating circuit circulation.
No feedback from the air pressure switch	Check that the dimensions of the flue gas system correspond to those stipulated. Check flue gas system for leaks and unrestricted flow. Check cable connections to the fan motor, the fan power supply and the air pressure switch (see page 94).

Diagnostics using control unit (cont.)









Fault message display Control with standard pro- gramming unit		Comfortrol pro- gramming unit	Display Burner fault, red	System characteristics
l ₁ :0: 5	FAULT: 05	ON	Main circuit board VGL 10 in fault state	
l ₁ :0: 6	FAULT: 06	OFF	The boiler only operates with burner stage 1	
l ₁ :0: 8	FAULT: 08	ON	Main circuit board VGL 10 in fault state	
l ₁ :0: 9	FAULT: 09	ON	Main circuit board VGL 10 in fault state	
l ₁ :0: A	FAULT: 0A	ON	Main circuit board VGL 10 in fault state	
l ₁ :0: b	FAULT: 0b	ON	Main circuit board VGL 10 in fault state	
l ₁ :0: C	FAULT: 0C	ON	Main circuit board VGL 10 in fault state	
l ₁ :0: d	FAULT: 0D	ON	Burner control unit fault	

5692 502 GB

Cause	Remedy
No fan speed is recorded	Check the fan motor. Check the wiring. Check main circuit board VGL 10.
The fan speed for burner stage 2 is not achieved or solenoid valve for burner stage 2 is not being controlled	Check that the dimensions of the flue gas system correspond to those stipulated. Check flue gas system for leaks and unrestricted flow. Check cable connections to the fan motor or the solenoid valve, the fan or solenoid valve power supply and the air pressure switch (see page 94).
The fan speed for burner stage 1 is not achieved	Check that the dimensions of the flue gas system correspond to those stipulated. Check flue gas system for leaks and unrestricted flow. Check cable connections to the fan motor, the fan power supply and the air pressure switch (see page 94).
Air pressure switch feedback available	Check the air pressure switch. Check the wiring.
The fan speed for the start load is not achieved	Check the air pressure switch. Check that the dimensions of the flue gas system correspond to those stipulated. Check flue gas system for leaks and unrestricted flow. Check cable connections to the fan motor, the fan power supply and the air pressure switch (see page 94).
Zero speed (fan idle) not achieved	Check the fan motor. Check the wiring.
Solenoid valve for burner stage 1 or 2 still enabled after shutdown	Check the control unit or the burner control unit
Equipment is still disabled	Press reset key  once

Diagnostics using control unit (cont.)

Fault message display Control with standard pro- gramming unit		Comfortrol pro- gramming unit	Display Burner fault, red	System characteristics
↳0: F		FAULT: 0F	ON	Main circuit board VGL 10 in fault state
↳1: 4		FAULT: 14	ON	Main circuit board VGL 10 in fault state
↳2: 5		FAULT: 25	OFF	Boiler runs with a high boiler water temperature
↳3: 5		FAULT: 35	OFF	Boiler does not start
↳9: 6		FAULT: 96	OFF	Boiler does not start

Cause	Remedy
Programming position in conjunction with Vitosoft	Press reset key  once
Dwell time for enable solenoid valve for burner stage 2 exceeded	Check burner control unit and replace, if required
Emissions test switch  has been on  for 30 minutes	Set emissions test switch  to 
Press reset 	Check connection of PCB in front frame and of switch PCB (see page 94)
—	<p>If a control demand is present (plug  terminal T2 = 230 V): replace burner control unit LMO 54.220 ...</p> <p>If no control demand is present (plug  terminal T2 = 0 V): replace the main PCB VGL 10</p>

Repairs

Scanning actual and set temperatures for Control with

- *standard programming unit, see page 75,*
- *Comfortrol programming unit, see page 93.*

Checking the outside temperature sensor

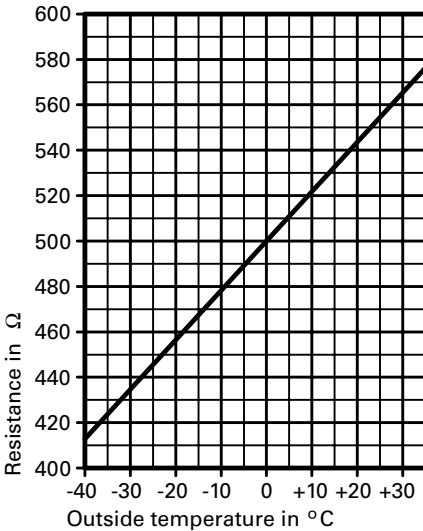

1. Pull plug-in connector X6 off the control unit.
2. Test the outside temperature sensor resistance across terminals X6.3 and X6.4 on the pulled plug-in connector and compare with the curve.
3. Where actual values deviate severely from curve values, disconnect the wires at the sensor and repeat this test directly on the sensor.
4. Depending on the result, replace cable or outside temperature sensor.

Repairs (cont.)

Check the boiler temperature sensor or cylinder temperature sensor

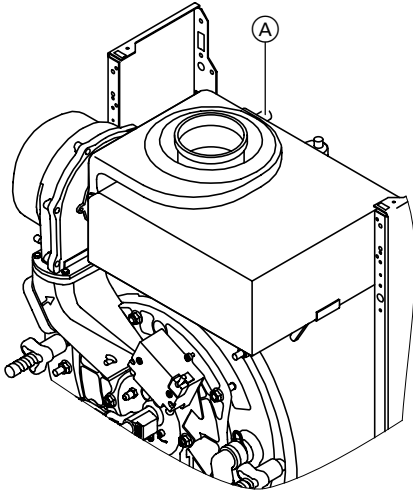

1. Pull the leads off boiler temperature sensor (A) or off plug X7 of the cylinder temperature sensor.
2. Check the sensor resistance and compare actual values with the curve.
3. Replace the sensor in case of severe deviation.

Warning:

The boiler temperature sensor is immersed in the heating water. Drain the boiler before replacing the sensor.

(A) Boiler temperature sensor

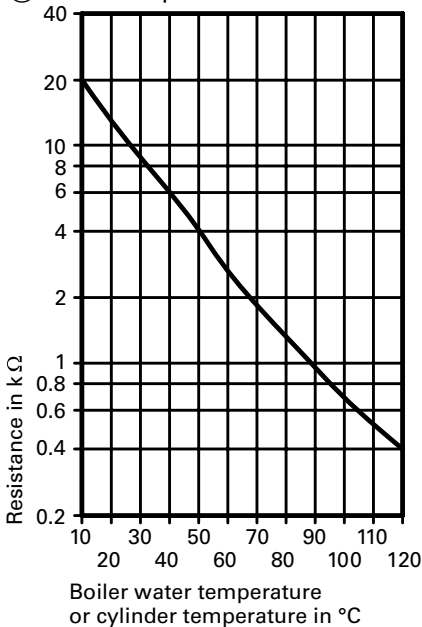

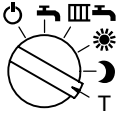

Repairs (cont.)

Relay test (for standard programming unit)

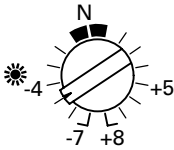

1. Set the heating program selector to **T**.



2. Select the required position using rotary selector .

Function	Rotary selector 	Flashing display
Drive three-way valve	N	⌋:0: 4
Heating circuit pump A	-1	⌋:0: 2
Heating circuit pump with extension kit for a heating circuit with mixer	-2	⌋:0: 3
Mixer open	+1	⌋:0: 8
Mixer closed	+2	⌋:0: 7
DHW circulation pump	-4	⌋:0: d
No function	-3	⌋:0: 1
Burner stage 1 ON and heating circuit pump ON	-5	Boiler water temp. display
Burner stage 2 ON and heating circuit pump ON	-6	Boiler water temp. display

3. Return the heating program selector and rotary selector  to their original positions.

Repairs (cont.)

Relay test (for Comfortrol programming unit)

Open flap:

Menu item	Key
→ SYSTEM	D
→ INSTALLER SETUP	C
→ CODE PLS	B-C-C-B
→ DIAGNOSIS	A
→ RELAY TEST	A

Note

Relays which have not been mentioned are not relevant. The burner stays off during the relay test if there is no heat demand.

You can select the required relay with CONTINUE **A** and check its function.

Display	Meaning
01 – Burner stage 1 <ST41> ON	N/A
02 – Heating circuit pump A <ST20> ON	Circulation pump
03 – Heating circuit pump B <ST20B> ON	Heating circuit pump for extension kit with mixer three-way valve
04 – Cylinder loading pump <ST21> ON	
07 – Mixer HC B <ST52B> CLOSED	Mixer closed* ¹
08 – Mixer HC B <ST52B> OPEN	Mixer open* ¹
10 – Modulation <ST90> CLOSED Burner <ST41> ON	Burner stage 1 Circulation pump
11 – Modulation <ST90> OPEN Burner <ST41> ON	Burner stage 2 Circulation pump
13 – DHW circulation pump <ST28> ON	DHW circulation pump* ²
14 – Central fault message <ST50> ON	Central fault message* ²

*¹Only in conjunction with mixer extension kit, part no. 7450 058.

*²Only in conjunction with connection extension, part no. 7404 582.

Repairs (cont.)

Resetting high limit safety cut-out

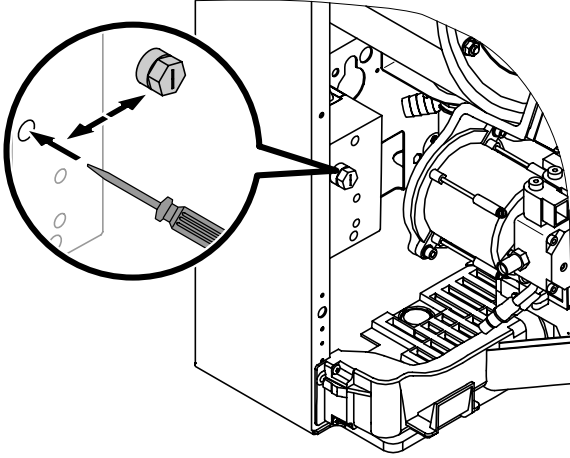

Checking the fuse

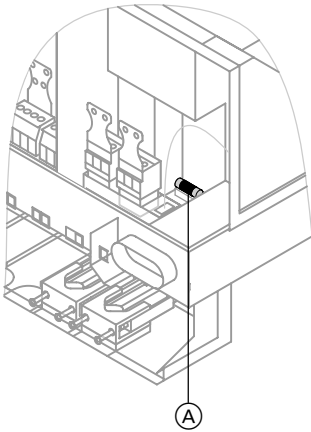

1. Switch OFF the power supply or mains electrical isolator and safeguard against unauthorised reconnection.
2. Pull out fuse F3 (6.3 A) **(A)** by its handle from its base and check.

Repairs (cont.)

Extension kit for one heating circuit with mixer

Checking the rotational direction of the mixer motor

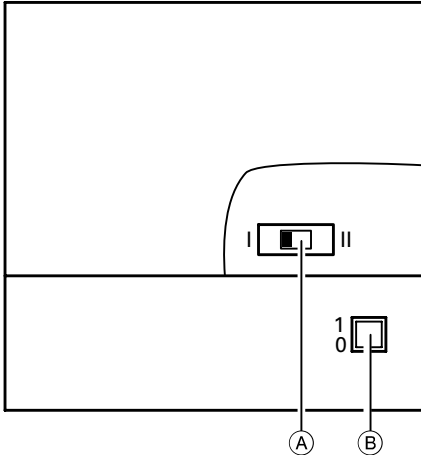

- (A) Switch for rotational direction
- (B) Main ON/OFF switch

1. Switch OFF and restart the motor at the main ON/OFF switch. The device will carry out the following self-test:
 - Close mixer (150 seconds)
 - Pump on (10 seconds)
 - Open mixer (10 seconds)
 - Close mixer (10 seconds)
 Then standard control mode recommences.

2. Note the rotational direction of the mixer motor during the self-test. Then set mixer manually to open.

The flow temperature sensor must now sense a higher temperature. If the temperature falls, either the motor is turning in the wrong direction or the mixer set is incorrectly fitted.

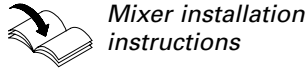

Mixer installation instructions

3. Adjust the rotational direction of the mixer motor (if required).
 - Switch position I for central heating return from the l.h. side (delivered condition).
 - Switch position II for central heating return from the r.h. side.

DIP switch S1.1

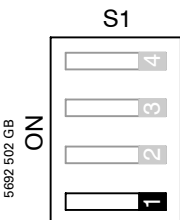

If an extension kit for a heating circuit with mixer and a Vitotronic 050 are connected via a Viessmann 2-wire BUS, set DIP switch S1.1 on extension kit to OFF.

Repairs (cont.)



Check Vitotronic 050 (accessory)

To control a Vitotronic 050, the Viessmann 2-wire BUS extension module is required in the boiler control unit, plus an additional communication module in Vitotronic 050.

Checking Viessmann 2-wire BUS and data connection to Vitotronic 050

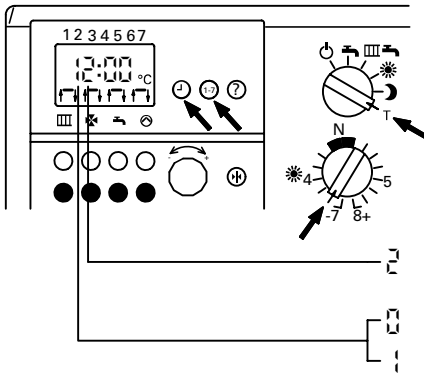
With standard programming unit



1. Set the heating program selector to T.
2. Set rotary selector  to -6.
3. Simultaneously press keys  and .

4. Evaluate the display.

With Vitotronic 050

Extension module not recognised
Extension module recognised

5. Check for correct installation if the extension module or Vitotronic 050 are not recognised.

Note

A green LED on the extension module flashes if the data BUS is active. If the LED is OFF, one of the data cable cores may be interchanged X5.3-X5.4.

Repairs (cont.)

With menu-guided Comfortrol programming unit

1. Check the Comfortrol programming unit via brief scan 2, to establish whether the extension module is installed.

Calling up brief scan 2

Open flap:

Menu item	Key
→ SYSTEM	D
→ OPERATING STATE	B
→ CONTINUE	A
	until text
	Brief
	scan 2
	appears

Extension module

Here, the final digit means:

2____0 = No extension module
Viessmann 2-wire BUS
recognised

2____1 = Extension module
Viessmann 2-wire BUS
recognised

Vitotronic 050

The 2nd digit from the left means:

_2____ = Extension kit for one heating circuit with mixer or
Vitotronic 050 recognised

Note

A green LED on the extension module flashes if the data BUS is active. Data cables X5.3-X5.4 may be interchanged if the LED is not lit.

Connection and wiring diagrams, see page 97.

2. Check correct installation if the expansion module or Vitotronic 050 are not recognised.

Repairs (cont.)

Checking rotary selector setting on Vitotronic 050 communication module

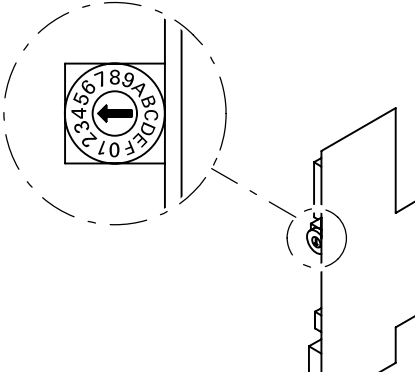

The communication module rotary selector must be set to 4.

Note



Please observe the respective installation documents for Vitotronic 050.

Set the rotary selector to 5 if, in addition to Vitotronic 050, an extension kit for one heating circuit with mixer is also connected.

Set the rotary selector on any additional Vitotronic 050 that may be connected to 6, etc.

Strapping plug configuration and coding

Strapping plug configuration on PCB VR 20

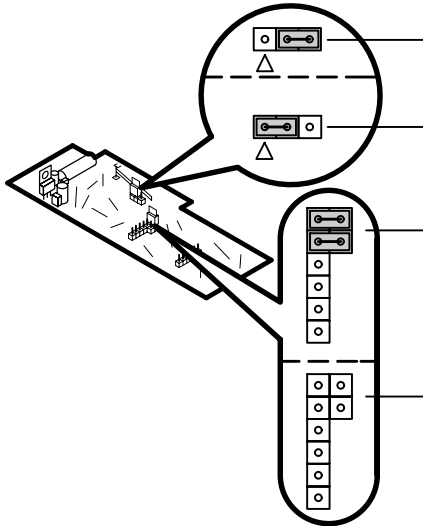

Strapping plug X6

As delivered condition without external burner blocking function.

Including External burner blocking function (only if the contact on plug X 6.1-X6.2 is connected).

Strapping plugs X2-X4

As delivered condition without Viessmann 2-wire BUS extension module:

Two strapping plugs installed as shown.

With Viessmann 2-wire BUS extension module:
Both strapping plugs removed.

External demand (on site)

With standard programming unit

Change coding address 30:00 to 30:01 and 35:00 to 35:01.

With Comfortrol programming unit

Change coding address 011:000 to 011:001 and 027:000 to 027:001.

Note

The boiler is started in accordance with the setting of coding address 125 (standard programming unit) or 0C5 (Comfortrol programming unit).

The boiler water temperature is maintained to its set value in accordance with the setting of coding address 102 (standard programming unit) or 0A2 (Comfortrol programming unit).

Strapping plug configuration and coding (cont.)

External blocking

(only if the contact on plug X6.1-X6.2 is connected)

1. Pull out PCB VR 20 (A).
2. Re-position the strapping plug X6 (B).
3. Reinstall PCB (A).

Note

The boiler is shut down according to the setting of coding address 108 (standard programming unit) or 0A8 (Comfortrol programming unit).

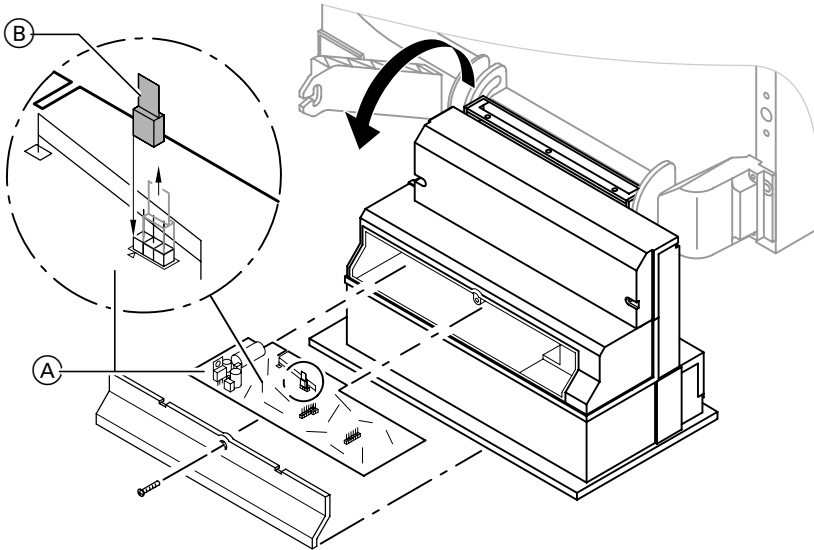

Strapping plug configuration and coding (cont.)

External heating program changeover (telephone contact)





An auxiliary device (e.g. Vitocom 300) must be connected for this function.

The heating program which was manually pre-selected on the boiler control unit can only be changed from a central control station or via telephone and code transmitter. The changeover occurs between the heating programs allocated in the

table. However, the heating program selector position remains unchanged. A further call-up reloads the preselected heating program.

With standard programming unit

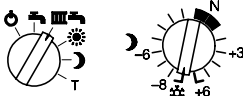
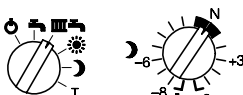
Change coding address 35:00 to 35:01.

Preselected heating program	Changed heating program (after telephone call)
	<ul style="list-style-type: none"> ■ Constant central heating with standard room temperature ■ Constant DHW heating
	Standby mode with frost protection
	Standby mode with frost protection
	<ul style="list-style-type: none"> ■ Constant central heating with standard room temperature ■ Constant DHW heating
	Standby mode with frost protection
	<ul style="list-style-type: none"> ■ Constant central heating with standard room temperature ■ Constant DHW heating

Strapping plug configuration and coding (cont.)

With Comfortrol programming unit

Note

If the heating circuit has been changed via telephone, the display will show the additional text (with the flap closed): TELE.PROG..

Change coding address 011:000 to 011:001.

Preselected heating program	Changed heating program (after telephone call)
	<ul style="list-style-type: none"> ■ Constant central heating with standard room temperature ■ Constant DHW heating
	Standby mode with frost protection
	<p>With code 0C8:001 (as delivered condition): Standby mode with frost protection</p> <hr/> <p>With code 0C8:000</p> <ul style="list-style-type: none"> ■ Constant central heating with standard room temperature ■ Constant DHW heating
	Standby mode with frost protection

Function description

Heating mode

The control unit determines a set boiler water temperature subject to outside temperature or room temperature (if a room temperature dependent remote control is connected) and the slope/level of the heating curve.

The determined set boiler water temperature is then transferred to the control unit.

Subject to the set and actual boiler water temperatures, the controller starts the burner and selects the operation of burner stage 1 or 2.

The boiler water temperature is limited by the temperature limiter to 78 °C.

The high limit safety cut-out locks out the burner at 100 °C boiler water temperature.

DHW heating

The DHW heating/loading will be activated, if the DHW cylinder temperature falls 2.5 K below the set cylinder temperature.

The burner and the cylinder loading pump are switched ON.

In the delivered condition, the set boiler water temperature lies 20 K above the set cylinder temperature.

If the actual cylinder temperature is 2.5 K above the set cylinder temperature, the burner will be switched OFF and the cylinder loading pump run-on will be activated.

Supplementary DHW heating

The supplementary heating facility will be activated if a control period of 10 minutes (e.g. 22:10 to 22:20 hrs) has been selected.

This period must lie outside the control range for normal DHW heating to enable the control unit to recognise the signal.

You can select the set temperature value for supplementary heating via coding address 107.

Function description (cont.)

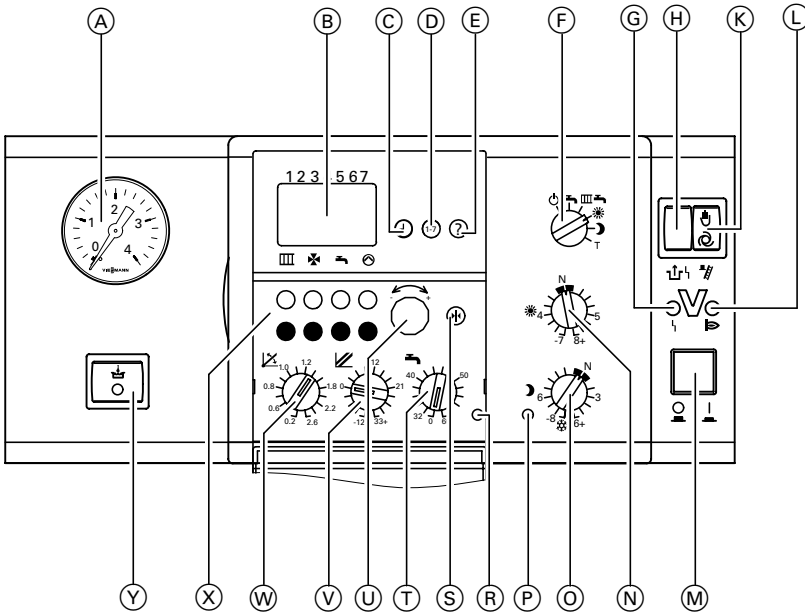

- | | |
|---|--|
| <ul style="list-style-type: none"> (A) Pressure gauge (B) Display (C) Time setting (D) Weekday setting (E) Scanning temperatures (F) Heating program selector switch <ul style="list-style-type: none"> ⏻ Standby mode 🔥 DHW only 🔥 Heating and DHW ☀️ Constant standard room temperature and DHW heating 🌙 Constantly reduced room temperature and DHW heating T Test position (G) Burner fault display (H) Burner fault reset (K) Emissions test switch | <ul style="list-style-type: none"> (L) Burner operation display (M) System ON/OFF switch (N) ☀️ Rotary selector, standard room temperature (O) 🌙 Rotary selector, reduced room temperature (P) Reduced room temperature display (R) 🔥 DHW heating display (S) Basic setting key (T) 🔥 Rotary selector, DHW temperature (U) ⬅️➡️ Rotary selector (V) 📈 Rotary selector, heating curve level (W) 📉 Rotary selector, heating curve slope (X) Start-up and shutdown time keys (Y) N/A |
|---|--|



Calling up coding level 1

Note

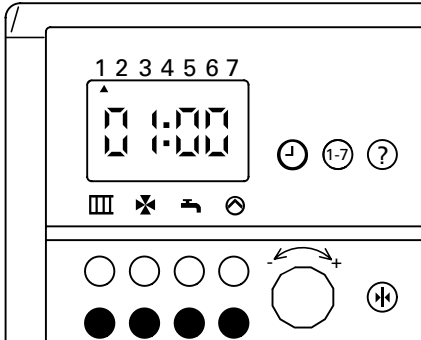
For a summary of the coding addresses of coding level 1, see page 64.





1. Calling up the coding level

Simultaneously press red key  and blue key .

Hold down these keys until, after approx. 5 seconds, 01:00 is displayed.

2. Coding address selection

Press key  and turn rotary selector  clockwise, until the required coding address is displayed.

3. Changing coding address

Press key **1-7** and turn rotary selector  until the required value appears.

4. Terminating coding

Press red key .

Heating curves

The heating curves illustrate the relationship between the outside temperature and the boiler water or the flow temperature.

To put it simply: the lower the outside temperature, the higher the boiler water or flow temperature.

The room temperature again depends on the boiler water or the flow temperature.

If different room temperatures are set, the curves will be adjusted parallel to the set room temperature axis.

Settings in delivered condition:

■ *Slope*  = 1.4

■ *Level*  = 0

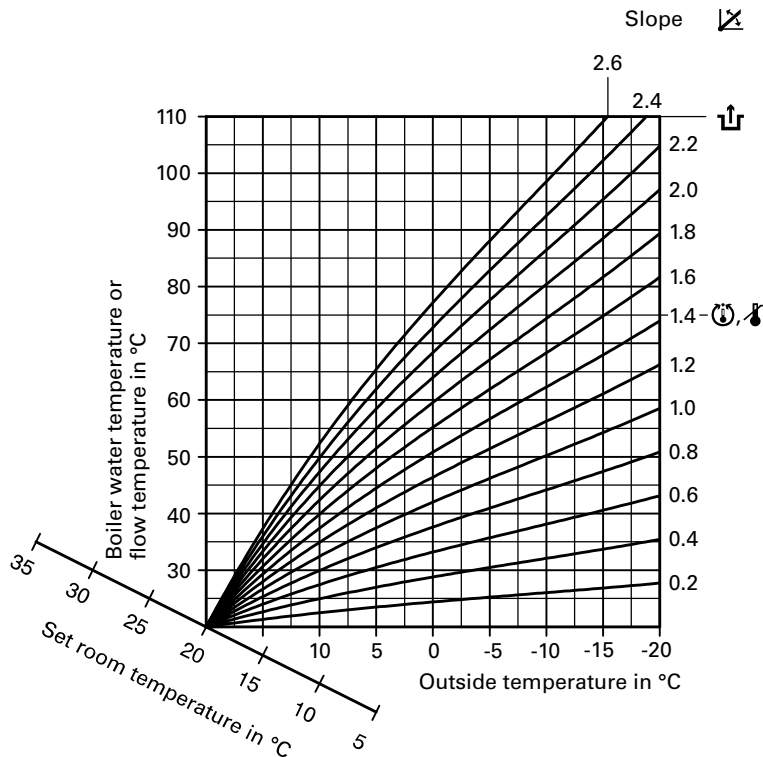

Adjusting heating curves

Set room temperature

Designs 04:00 and 04:01:
Heating circuit **without** mixer
Designs 04:02 and 04:03:
Heating circuit **with** mixer

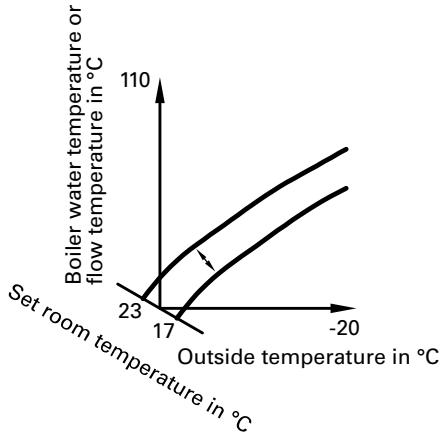

Control unit setting:

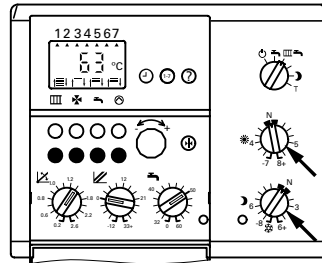

Heating curve slope

Designs 04:00 and 04:01:
Heating circuit **without** mixer
Designs 04:02 and 04:03:
Heating circuit **with** mixer

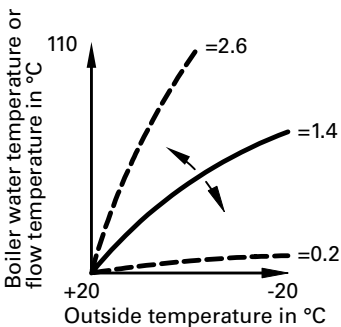

Control unit setting:

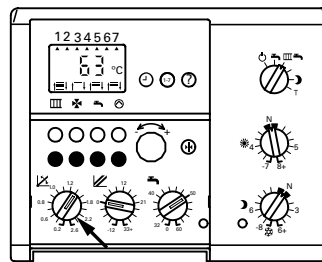

Setting of coding address 08

Slope setting range

08:00 = 0.2 to 08:15 = 2.6

(Change per step: 0.2)

As delivered condition: 08:09 = 1.4.

Designs 04:02 and 04:03:
Heating circuit **without** mixer

Adjusting heating curves (cont.)

Heating curve level

Designs 04:00 and 04:01:
Heating circuit **without** mixer
Designs 04:02 and 04:03:
Heating circuit **with** mixer

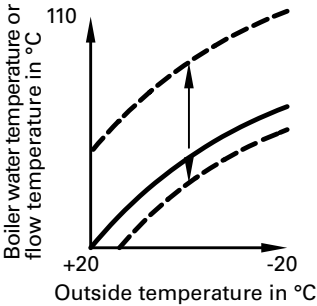

Control unit setting:

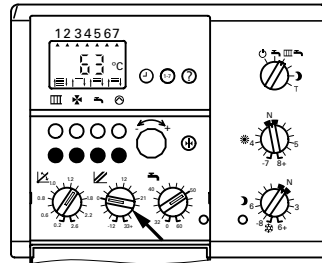

Differential temperature

Designs 04:02 and 04:03

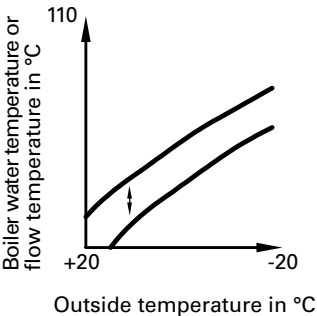

Setting of coding address 07
Setting range for differential temp. of
07:00 = 6 K to 07:15 = 36 K
(Change per step: 2 K)
As delivered condition: 07:01 = 8 K.

Note

If Vitotronic 050 is connected, the set differential temperatures add up (as delivered condition respectively 8 K). Therefore set the differential temperature at Vitotronic 050 appropriately lower.

Adjusting heating curves (cont.)

Maximum temperature limit

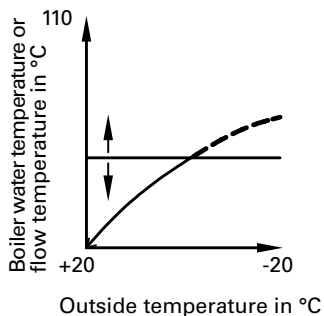

Heating circuit **without** mixer
Setting of coding address 06
Setting range of maximum temp. of
06:01 = 40 °C to 06:15 = 110 °C
(Change per step: 5 K)
As delivered condition: 06:10 = 85 °C.

Heating circuit **with** mixer
Setting of coding address 05
Setting range of maximum temp. of
05:00 = 35 °C to 05:15 = 110 °C
(Change per step: 5 K)
As delivered condition: 05:08 = 75 °C.

Overview coding level 1

⚠ Safety instruction

Coding addresses that are not described here must not be changed.

For a sequence of steps to call up coding level 1, see page 59.

Coding in delivered condition Address:value	Function mode	Coding change Address:value	Possible change
Boiler			
03:00	No DHW heating	03:01 03:02*1 03:14 03:15	<p>Cylinder temperature control</p> <p>Cylinder temperature control (optimised)</p> <p>Screed drying acc. to two optional temperature-time profiles. Observe DIN 4725-2.</p> <p>Screed drying acc. to temperature profile ① (DIN 4725)*2</p> <p>Screed drying acc. to temperature profile ② (ZV parquet & underfloor technology)*2</p>

*1 Automatic adjustment if a cylinder temperature sensor is connected; can be manually changed to 01.

*2 After this function has expired, the system automatically changes over to heating and DHW operating mode.

Overview coding level 1 (cont.)

Coding in delivered condition Address:value	Function mode	Coding change Address:value	Possible change
Boiler (cont.)			
06:10	Max. temperature limit set to 85 °C	06:00 to 06:15	Max. temperature limit variable between 35 and 110 °C
30:00	External heating program changeover	30:01	External request
35:00	External demand or external heating program changeover blocked	35:01	External demand or external heating program changeover active
40:01	Boiler water temp. display	40:00	Time display
Heating circuits			
04:00 ^{*1}	One heating circuit without mixer, without DHW heating	04:01 ^{*1} 04:02 04:03 ^{*1}	One heating circuit without mixer, with DHW heating One heating circuit without mixer, one heating circuit with mixer, without DHW heating One heating circuit without mixer, one heating circuit with mixer and with DHW heating
05:08 ^{*1}	Max. temperature limit set to 75 °C	05:00 to 05:15	Max. temperature limit variable between 35 and 110 °C
07:01 ^{*2}	Differential temperature set to 8 K	07:00 to 07:15	Differential temperature variable between 6 and 36 K

^{*1}For systems without mixer, address without mixer and with recognition of DHW heating will be set automatically, and therefore must be manually reset.

^{*2}Only for heating system designs 04:02 and 04:03.

Overview coding level 1 (cont.)

Coding in delivered condition Address:value	Function mode	Coding change Address:value	Possible change
--	----------------------	--	------------------------

Heating circuit pump (cont.)

08:09*1	Heating circuit without mixer: Heating curve slope $\frac{\Delta}{\Delta x}$ set to 1.4	08:00 to 08:15	Heating circuit without mixer: Slope $\frac{\Delta}{\Delta x}$ variable between 0.2 and 2.6
22:00	Heating circuit pump ON for heating system designs 04:02 and 04:03 (connection to plug 20A)	22:01	Heating circuit pump OFF for heating system designs 04:02 and 04:03

Cylinder

10:01	The circulation pump starts immediately	10:00	Circulation pump will be switched ON subject to boiler temp.
13:00	Circulation pump with run-on, up to max. 10 min	13:01	Circulation pump without run-on
14:00	Set boiler water temperature for cylinder loading acc. to the set cylinder temperature +20 K	14:01	The set boiler water temperature during cylinder loading equals 78 °C
15:01	W. DHW priority control	15:00	W/o DHW priority control
23:00	Setting range for DHW temperature 32 to 60 °C	23:01	Setting range for DHW temperature 52 to 80 °C

Heating circuit pump

11:01	Heating circuit pump speed for reduced mode acc. to coding address 044:___ at coding level 2	11:00	Heating circuit pump speed for reduced mode acc. to coding address 046:___ at coding level 2
12:01	With variable speed heating circuit pump (automatic recognition)	12:00	Stepped heating circuit pump (e.g. transitional mode for service)

*1 Only for heating system designs 04:02 and 04:03.

Overview coding level 1 (cont.)

Coding in delivered condition Address:value	Function mode	Coding change Address:value	Possible change
Heating circuit pump (cont.)			
16:01	With heating circuit pump logic function	16:00	Without heating circuit pump logic function
17:00	Heating circuit without mixer present	17:01	Heating circuit with mixer present
Remote control			
20:00	Without WS or RS remote control unit	20:01	With WS or RS remote control unit*1
32:01 33:00	Weather-compensated mode in heating and reduced mode	32:00*2 33:00*2	With room temperature hook-up in heating and reduced mode
		32:00*2 33:01*2	Weather-compensated mode in heating mode With room temperature hook-up in reduced mode
Changeover between summer and winter			
47:01	Automatic summer/winter changeover	47:00	Manual summer/winter changeover
50:03	Summer starts: March	50:01 to 50:12	January to December
51:05	Summer starts: last week of the month	51:01 to 51:05	Week 1 to week 5 of the selected month
52:07	Summer starts: last day of week (Sunday)	52:01 to 52:07	Monday to Sunday

*1The address is automatically set and must be manually reset.

*2Do not adjust in RS remote control connection.

Control with standard programming unit

Overview coding level 1 (cont.)

Coding in delivered condition Address: value	Function mode	Coding change Address: value	Possible change
Summer/winter changeover (cont.)			
53:10	Winter starts: October	53:01 to 53:12	January to December
54:05	Winter starts: last week of the month	54:01 to 54:05	Week 1 to week 5 of the selected month
55:07	Winter starts: last day of week (Sunday)	55:01 to 55:07	Monday to Sunday



Calling up coding level 2

Note

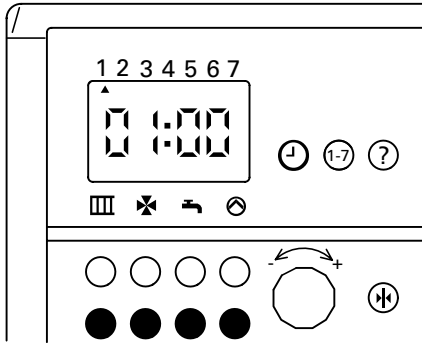
For systems with wall mounting fixtures, the programming unit must be plugged into the control unit, if coding is to be carried out at coding level 2. For a summary of the coding addresses of coding level 2, see page 70.





1. Calling up coding level 1

Simultaneously press red key  and blue key .



Hold down these keys until, after approx. 5 seconds, 01:00 is displayed.

2. Calling up coding level 2

Simultaneously press red key  and blue key .

Hold down both keys until, after approx. 5 seconds, the display changes (e.g. to 0:000).

3. Selecting coding address

Press key  and turn rotary selector  clockwise, until the coding address is displayed.

4. Changing coding address

Press key **1-7** and turn rotary selector  until the required value of the coding address appears.

5. Terminating coding

Press red key .

Overview coding level 2

For a sequence of steps to call up coding level 2, see page 69.

Coding in delivered condition Address:value	Function mode	Coding change Address:value	Possible change
Boiler			
038:040	Minimum flow temp. in heating mode	038:020 to 038:127	
042:075	Maximum boiler water temp. in heating mode	042:020 to 042:127	Max. possible boiler water temp. 82 °C
102:075	Set boiler water temp. for external demand 75 °C	102:000 to 102:127	Setting range of set boiler water temp. 0 to 127 °C (max. possible boiler water temp. 82 °C)
108:000	Signal external blocking enabled: see following table	108:001 to 108:007	Signal external blocking enabled: see following table

Modification types – coding address 108 external blocking

Coding	Heating circuit pump	Heating circuit with mixer (extension kit)		Cylinder loading pump	Burner
		Heating circuit pump	Mixer		
108:000	x	x	x	x	Blocked
108:001	OFF	OFF	Closed	OFF	Blocked
108:002	x	x	x	OFF	Blocked
108:003	x	OFF	Closed	x	Blocked
108:004	OFF	x	x	x	Blocked
108:005	OFF	x	x	OFF	Blocked
108:006	OFF	x	x	x	Blocked
108:007	OFF	OFF	Closed	x	Blocked

x = in a normal control function

Overview coding level 2 (cont.)

Coding in delivered condition Address:value	Function mode	Coding change Address:value	Possible change
Boiler (cont.)			
125:000	Signal external demand activated: see following table	125:001 to 125:011	Signal external demand activated: see following table

Modification types – coding address 125 external demand

Coding	Heating circuit pump	Heating circuit with mixer (extension kit)		Cylinder loading pump	Boiler water temperature
		Heating circuit pump	Mixer		
125:000	ON	OFF	Closed	OFF	Will be held at set value according to coding address 102
125:001	OFF	OFF	Closed	OFF	
125:002	x	OFF	Closed	OFF	
125:003	OFF	x	x	OFF	
125:004	ON	x	x	OFF	
125:005	x	x	x	OFF	
125:006	OFF	OFF	Closed	x	
125:007	ON	OFF	Closed	x	
125:008	x	OFF	Closed	x	
125:009	OFF	x	x	x	
125:010	ON	x	x	x	
125:011	x	x	x	x	

x = in a normal control function

Overview coding level 2 (cont.)

Coding in delivered condition Address:value	Function mode	Coding change Address:value	Possible change
Heating circuit pump			
044:020	Minimum heating circuit pump speed: approx. 1100 rpm	044:001 to 044:100* ¹	Lowest value for lower heating circuit pump speed: approx. 700 rpm Highest value for lower heating circuit pump speed: approx. 2700 rpm
045:065	Highest heating circuit pump speed: approx. 1750 rpm	045:001 to 045:100* ¹	Lowest value for upper heating circuit pump speed: approx. 700 rpm Highest value for upper heating circuit pump speed: approx. 2700 rpm
046:045	Heating circuit pump speed for reduced mode: approx. 1200 rpm	046:001 to 046:100* ¹	Lowest value for heating circuit pump speed in reduced mode: approx. 700 rpm Highest value for heating circuit pump speed in reduced mode: approx. 2700 rpm
109:098	Highest value for circulation pump speed during DHW heating	109:001 to 109:100* ¹	Lowest value for circulation pump speed during DHW heating Highest value for circulation pump speed during DHW heating

*¹Each step represents approx. 20 rpm.

Overview coding level 2 (cont.)

Coding in delivered condition Address:value	Function mode	Coding change Address:value	Possible change
Cylinder			
100:020* ¹	Differential temperature between set boiler water temperature and set cylinder temperature during DHW heating	100:010 to 100:050	Differential temperature setting range 10 to 50 °C
107:060	Temperature auxiliary function DHW heating (briefly heating DHW to 60 °C)	107:061 to 107:090	Setting range between 61 and 90 °C (max. possible boiler water temperature 82 °C)

¹Only effective with code 14:00.

Note

255 will be displayed for all non-listed coding addresses.

Brief scan

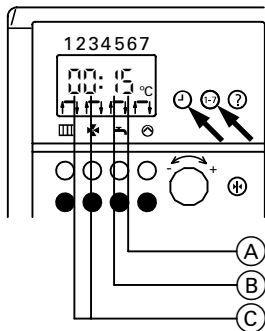

Simultaneously press keys ① and 1-7.

Meaning of display:

- Ⓐ set DHW plan in coding address 03^{*1}
- Ⓑ set heating plan in coding address 04^{*1}

Ⓒ KM BUS users:

02 with basic PCB VGL 10
(12) additionally with Vitocom 100

03 with basic PCB VGL 10 and
variable speed heating circuit
pump
(13) additionally with Vitocom 100

06 with basic PCB VGL 10 and
extension kit for one heating
circuit with mixer^{*2}
(16) additionally with Vitocom 100

07 with basic PCB VGL 10,
extension kit for one heating
circuit with mixer^{*2} and
variable speed heating circuit
pump
(17) additionally with Vitocom 100

^{*1}For systems with wall mounting fixture,
plug the programming unit into the
control unit.

^{*2}The system only recognises the
extension kit if it is connected via the
KM BUS.
Not if connected via the 2-wire
Viessmann BUS.

Scanning temperatures

The programming unit enables the temperatures of connected sensors to be scanned as set and actual values.

Scanning actual temperatures

1. Select the ID of the respective temperature from the table.

ID	Meaning of display	Actual temperature in °C (display example)
1* ¹	Outside temperature	1: 8 °C
2	Low loss header temperature	2: 45 °C
3	Boiler water temperature	3: 63 °C
4* ²	Flow temperature	4: 44 °C
5* ³	Cylinder temperature	5: 50 °C
7* ⁴	Room temperature	7: 20 °C

*¹The display value takes weather conditions into consideration, such as wind, solar radiation and wall temperature of the building.

*²Only in connection with the extension kit for heating circuits with mixer.

*³Only if the sensor is connected or activated.

*⁴Only if the programming unit is set into the wall mounting base as room temperature dependent remote control unit.

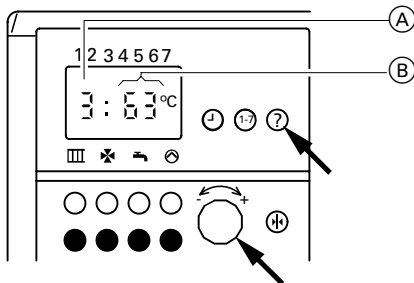

2. Press key ? and turn rotary selector \leftarrow \rightarrow clockwise or anti-clockwise, until ID (A) for the respective temperature appears in the display. At the same time, current temperature (B) will be displayed.

Scanning temperatures (cont.)

Scanning set temperatures

Note

For systems with wall mounting base, the programming unit must be plugged into the control unit to be able to scan set temperatures.

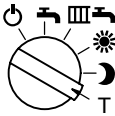

1. Set the heating program selector to **T**.
The display, the reduced room temperature LED and the DHW heating LED flash.
2. Select the ID of the respective temperature from the table.

ID	Meaning of display	Set temperature in °C (display example)
3	Set boiler water temperature	3: 65 °C
4*1	Set flow temperature	4: 44 °C
5*2	Set DHW water temperature	5: 55 °C

*1 Only in connection with the extension kit for heating circuits with mixer.

*2 Only if the sensor is connected or activated.

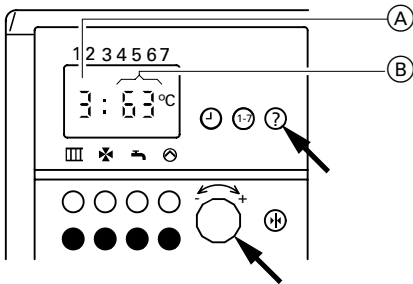

3. Press key **?** and turn rotary selector $\leftarrow \rightarrow$ clockwise or anti-clockwise, until ID **(A)** for the respective temperature appears in the display.
At the same time, current temperature **(B)** will be displayed.

Function description

Heating mode

The control unit determines a set boiler water temperature subject to outside temperature or room temperature (if a room temperature dependent remote control is connected) and the slope/level of the heating curve.

The determined set boiler water temperature is then transferred to the control unit.

Subject to the set and actual boiler water temperatures, the control unit starts the burner and selects the operation of burner stage 1 or 2.

The boiler water temperature is limited to 78 °C by the temperature limiter.

The high limit safety cut-out locks out the burner at 100 °C boiler water temperature.

DHW heating

The DHW heating will be activated if the cylinder temperature falls 2.5 K below the set cylinder temperature.

The burner and the cylinder loading pump are switched ON.

In the delivered condition, the set boiler water temperature lies 20 K above the set cylinder temperature.

If the actual cylinder temperature is 2.5 K above the set cylinder temperature, the burner will be switched OFF and the cylinder loading pump run-on will be activated.

Supplementary DHW heating

The supplementary heating facility will be activated if a control period of 10 minutes (e.g. 22:10 to 22:20 hrs) has been selected.

This period must lie outside the control range for normal DHW heating to enable the control unit to recognise the signal.

You can select the set temperature value for supplementary heating in coding address 0A7.

Function description (cont.)

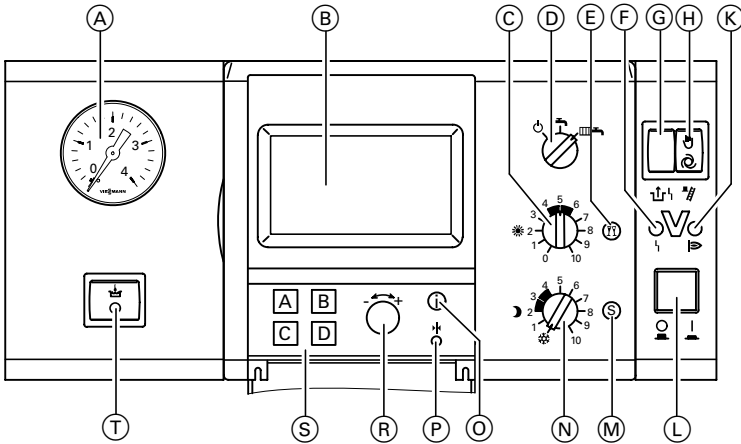

- | | |
|--|---|
| (A) Pressure gauge | (H) Emissions test switch |
| (B) Display | (K) Burner operation display |
| (C) ☀ Rotary selector, standard room temperature | (L) System ON/OFF switch |
| (D) Heating program selector switch | (M) Economy key |
| ☰ Standby mode | (N) 🌙 Rotary selector, reduced room temperature |
| 🚰 DHW only | (O) Information key |
| 🏠 Heating and DHW | (P) Basic settings key |
| (E) Party key | (R) -/+ Rotary selector |
| (F) Burner fault display | (S) Selection keys |
| (G) Burner fault reset | (T) N/A |

Calling up coding addresses

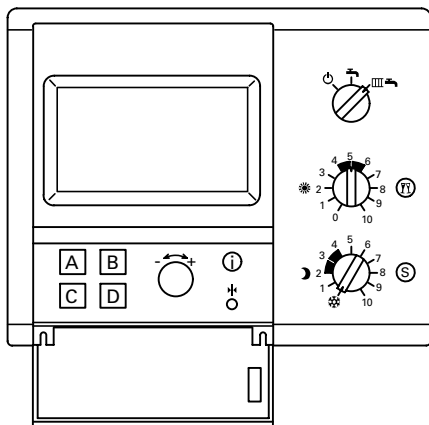

Open flap:

Menu item	Key
→ SYSTEM	D
→ INSTALLER SETUP	C
→ CODE PLS:	B-C-C-B
→ CODE 1	B
or	
CODE 2	C

All settings are implemented in the installer setup menu, where you will find code 1 (the most important coding addresses in plain text) and code 2 (all coding addresses).

Select the required coding address by pressing **A** (CONTINUE) or **B** (BACK). Change the relevant coding address with rotary selector $\leftarrow +$ (CHANGE). Confirm the change by pressing **D** (the change will then be saved).

Any changes made and confirmed in code 1 will be automatically adopted into code 2 and vice versa.

Heating curves

The heating curves illustrate the relationship between the outside temperature and the boiler water or the flow temperature.

To put it simply: the lower the outside temperature, the higher the boiler water or flow temperature.

The room temperature again depends on the boiler water or the flow temperature.

If different room temperatures are set, the curves will be adjusted parallel to the set room temperature axis.

Settings in delivered condition:

■ *Slope* = 1.4

■ *Level* = 0

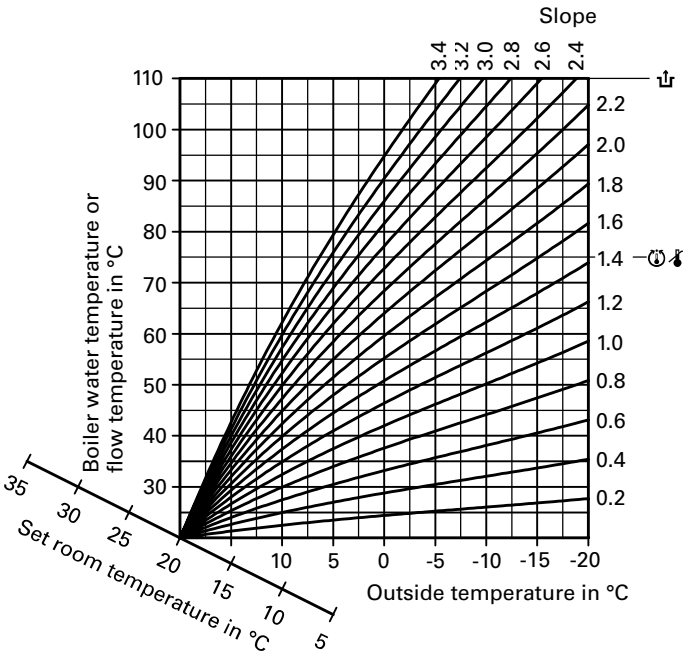

Adjusting heating curves

Note

Heating circuit A = Heating circuit **without** mixer

Heating circuit B = Heating circuit **with** mixer

Heating curve slope

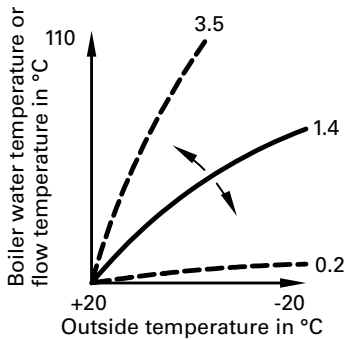

After opening the programming unit flap, take the following menu path:

Menu item	Key
→ HEATING	
CIRCUIT A	A
or	
HEATING	
CIRCUIT B	B
→ HEATING CURVE	B
→ CHANGE	A

Heating curve level

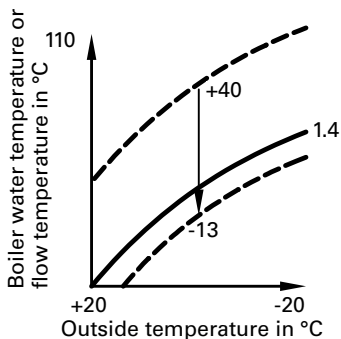

After opening the programming unit flap, take the following menu path:

→ HEATING	
CIRCUIT A	A
or	
HEATING	
CIRCUIT B	B
→ HEATING CURVE	B
→ CHANGE	2 × A

Summary of coding addresses

Safety instruction

Coding addresses that are not described here must not be changed.

For a sequence of steps to call up the coding addresses, see page 79.

Coding in delivered condition Address:value	Function mode	Coding change Address:value	Possible change
Boiler			
011:000	External demand or external heating program changeover blocked	011:001	External demand or external heating program changeover active
027:000	External heating program changeover	027:001	External request
038:020	Minimum flow temp. in heating mode	038:020 to 038:127	
042:075	Maximum boiler water temp. in heating mode	042:020 to 042:127	Max. possible boiler water temp. 82 °C
099:000	Optional connection DHW circulation pump	099:001	Output signal DHW heating active
0A2:075	Set boiler water temp. for external demand 75 °C	0A2:000 to 0A2:127	Setting range of set boiler water temp. 0 to 127 °C (max. possible boiler water temperature 82 °C)

Summary of coding addresses (cont.)

Coding in delivered condition Address:value	Function mode	Coding change Address:value	Possible change
Boiler (cont.)			
0A8:000	Signal external blocking enabled: see following table	0A8:001 to 0A8:007	Signal external blocking enabled: see following table

Modification types – coding address 0A8 external blocking

Coding	Heating circuit pump	Heating circuit with mixer (extension kit)		Cylinder loading pump	Burner
		Heating circuit pump	Mixer		
0A8:000	x	x	x	x	Blocked
0A8:001	OFF	OFF	Closed	OFF	Blocked
0A8:002	x	x	x	OFF	Blocked
0A8:003	x	OFF	Closed	x	Blocked
0A8:004	OFF	x	x	x	Blocked
0A8:005	OFF	x	x	OFF	Blocked
0A8:006	OFF	x	x	x	Blocked
0A8:007	OFF	OFF	Closed	x	Blocked

x = in a normal control function

Summary of coding addresses (cont.)

Coding in delivered condition Address: value	Function mode	Coding change Address: value	Possible change
Boiler (cont.)			
0B8:000	No DHW heating	0B8:001 0B8:002*1 0B8:014 0B8:015	Cylinder temperature control Cylinder temperature control (optimised) Screed drying acc. to two optional temperature-time profiles. Observe DIN 4725-2. Screed drying acc. to temperature profile ① (DIN 4725)*2 Screed drying acc. to temperature profile ② (ZV parquet & under-floor technology)*2

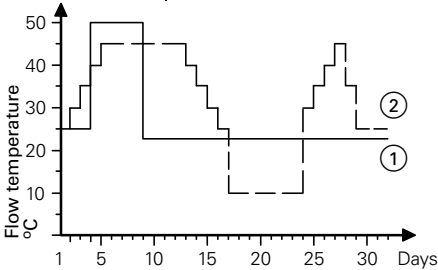

*1 Automatic adjustment if a cylinder temperature sensor is connected; can be manually changed to 001.

*2 After this function has expired, the system automatically changes over to heating and DHW operating mode.

Summary of coding addresses (cont.)

Coding in delivered condition Address:value	Function mode	Coding change Address:value	Possible change
Boiler (cont.)			
0C5:000	Signal external demand activated: see following table	0C5:001 to 0C5:011	Signal external demand activated: see following table

Modification options – coding address 0C5 external demand

Coding	Heating circuit pump	Heating circuit with mixer (extension kit)		Cylinder loading pump	Boiler water temperature
		Heating circuit pump	Mixer		
0C5:000	ON	OFF	Closed	OFF	Will be held at set value according to coding address 0A2
0C5:001	OFF	OFF	Closed	OFF	
0C5:002	x	OFF	Closed	OFF	
0C5:003	OFF	x	x	OFF	
0C5:004	ON	x	x	OFF	
0C5:005	x	x	x	OFF	
0C5:006	OFF	OFF	Closed	x	
0C5:007	ON	OFF	Closed	x	
0C5:008	x	OFF	Closed	x	
0C5:009	OFF	x	x	x	
0C5:010	ON	x	x	x	
0C5:011	x	x	x	x	

x = in a normal control function

Summary of coding addresses (cont.)

Coding in delivered condition Address:value	Function mode	Coding change Address:value	Possible change
Boiler (cont.)			
0C8:001	External heating program changeover Contact opened: Central heating ON/DHW heating ON (according to a time program). Contact closed: Central heating OFF/DHW OFF.	0C8:000	External heating program changeover Contact opened: Central heating ON/DHW heating ON (according to a time program). Contact closed: Constant central heating ON/DHW ON (independent of set time program).
Heating circuits			
000:000	One heating circuit without mixer, without DHW heating	000:001 ^{*1} 000:002 ^{*2} 000:003 ^{*1, 2}	One heating circuit without mixer, with DHW heating One heating circuit without mixer, one heating circuit with mixer, without DHW heating One heating circuit without mixer, one heating circuit with mixer and with DHW heating
014:000 ^{*3}	Party key \overline{YY} affects heating circuit B	014:001 ^{*3}	Party key \overline{YY} affects heating circuits A and B
Cylinder			
003:001	With priority switching to heating circuit pump(s)	003:000	Without priority switching to heating circuit pump(s)

^{*1}The coding for systems with DHW heating is automatically recognised.

^{*2}These codings also apply to one heating circuit without mixer and one heating circuit with mixer.

^{*3}Only for heating system designs 000:002 and 000:003 (heating systems with one heating circuit with mixer).

Summary of coding addresses (cont.)

Coding in the delivered condition Address:value	Function mode	Coding change Address:value	Possible change
Cylinder (cont.)			
007:000	Setting range for DHW temp. 10 to 60 °C	007:001	Setting range for DHW temp. 10 to 70 °C Warning: Observe the max. permissible cylinder water temp.
017:001	The circulation pump starts immediately	017:000	Circulation pump will be switched ON subject to boiler temp.
018:000	Circulation pump with run-on	018:001	Circulation pump without run-on
028:000	During DHW heating, boiler water temp. is a max. of 20 K higher than set cylinder temp.	028:001	During DHW heating, boiler water temp. is limited by temperature limiter to 78 °C
047:___	Actual temp. at cylinder temp. sensor <input type="text" value="4"/> in °C (no adjustment possible)		
0A0:020* ¹	Differential temp. between set boiler water temp. and set cylinder temp. during DHW heating	0A0:010 to 0A0:050	Differential temp. setting range 10 to 50 °C
0A7:060	Set value of the auxiliary function for DHW heating (heats DHW briefly to 60 °C)	0A7:061 to 0A7:070	Setting range between 61 and 70 °C

*¹Only effective with code 028:000 .

Summary of coding addresses (cont.)

Coding in the as delivered condition Address:value	Function mode	Coding change Address:value	Possible change
Heating circuit pump			
005:001	With heating circuit pump logic function	005:000	Without heating circuit pump logic function
006:001	Heating circuit pump speed for reduced range acc. to coding address 044:___	006:000	Heating circuit pump speed for reduced range acc. to coding address 046:___
013:001	With variable speed heating circuit pump (automatic recognition)	013:000	Stepped heating circuit pump (e.g. transitional mode for service)
044:020	Minimum heating circuit pump speed: approx. 1100 rpm	044:001 to 044:100* ¹	Lowest value for lower heating circuit pump speed: approx. 700 rpm Highest value for lower heating circuit pump speed: approx. 2700 rpm
045:065	Highest heating circuit pump speed: approx. 1750 rpm	045:001 to 045:100* ¹	Lowest value for upper heating circuit pump speed: approx. 700 rpm Highest value for upper heating circuit pump speed: approx. 2700 rpm
046:045	Heating circuit pump speed for reduced mode: approx. 1200 rpm	046:001 to 046:100* ¹	Lowest value for heating circuit pump speed in reduced mode: approx. 700 rpm Highest value for heating circuit pump speed in reduced mode: approx. 2700 rpm

*¹Each step represents approx. 20 rpm.

Summary of coding addresses (cont.)

Coding in the as delivered condition Address:value	Function mode	Coding change Address:value	Possible change
Heating circuit pump (cont.)			
0A9:098	Highest value for circulation pump speed during DHW heating	0A9:001 to 0A9:100 ^{*1}	Lowest value for circulation pump speed during DHW heating Highest value for circulation pump speed during DHW heating
Programming unit or remote control unit			
009:000	Boiler water temp. display	009:001	Display of outside temperature
019:000	Weather-compensated mode (WS function) for all connected heating circuits	019:001 ^{*2}	<ul style="list-style-type: none"> ■ For systems with one heating circuit without mixer or one heating circuit with mixer: Operation with room temperature hook-up (RS function) ■ For systems with one heating circuit without mixer and one heating circuit with mixer: Weather-compensated mode (WS function) for the heating circuit without mixer and operation with room temperature hook-up (RS function) for the heating circuit with mixer

^{*1}Each step represents approx. 20 rpm.

^{*2}This conversion is only appropriate if programming unit is set into wall mounting fixture.

Summary of coding addresses (cont.)

Coding in the as delivered condition Address:value	Function mode	Coding change Address:value	Possible change
Programming unit or remote control unit (cont.)			
019:000 (cont.)	Weather-compensated mode (WS function) for all connected heating circuits	019:002* ¹	<ul style="list-style-type: none"> ■ For systems with one heating circuit without mixer or one heating circuit with mixer: Weather-compensated mode (WS function) in heating mode and operation with room temp. hook-up (RS function) in setback mode ■ For systems with one heating circuit without mixer and one heating circuit with mixer: Weather-compensated mode (WS function) for the heating circuit without mixer and weather-compensated mode in heating mode, and operation with room temp. hook-up in setback mode (WS/RS function) for the heating circuit with mixer
020:000	Without WS or RS remote control unit	020:001	With WS or RS remote control unit* ²
049:___	Operating hours hundreds 3rd digit from the left	049:000	Resetting hours run
050:___	Operating hours units 3rd digit and tens 2nd digit from the left	050:000	Resetting hours run

*¹This conversion is only appropriate if programming unit is set into wall mounting fixture.

*²The address is automatically set and must be manually reset.

Summary of coding addresses (cont.)

Coding in the as delivered condition Address:value	Function mode	Coding change Address:value	Possible change
Programming unit or remote control unit (cont.)			
0D5:000	Standard display with closed flap	0D5:001	Large display of time and outside temp. with closed flap
0D6:000	Temperature display in °C (° Celsius)	0D6:001	Temperature display in °F (° Fahrenheit)
Changeover between summer and winter			
0C7:003	Automatic (radio clock module will be automatically recognised)	0C7:000 0C7:001 0C7:002	S/W. manual changeover/ change of date blocked Automatic S/W. changeover Manual S/W. changeover/ change of date enabled
0C9:003	Summer starts: March	0C9:001 to 0C9:012	January to December
0D0:005	Summer starts: last week of the month	0D0:001 to 0D0:005	Week 1 to week 5 of the selected month
0D1:007	Summer starts: last day of week (Sunday)	0D1:001 to 0D1:007	Monday to Sunday
0D2:010	Winter starts: October	0D2:001 to 0D2:012	January to December
0D3:005	Winter starts: last week of the month	0D3:001 to 0D3:005	Week 1 to week 5 of the selected month
0D4:007	Winter starts: last day of week (Sunday)	0D4:001 to 0D4:007	Monday to Sunday

Brief scan

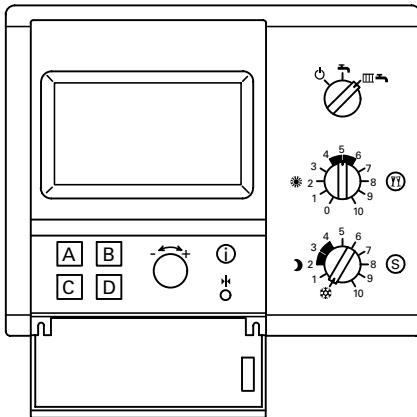

Calling up brief scan 1

Open flap:

Menu item	Key
→ SYSTEM	D
→ OPERATING STATE	B
→ CONTINUE	A

until Brief scan 1 appears

The 3rd and 4th digit from the left (e.g. __02__) have the following meaning:

02 with basic PCB VGL 10
(12) additionally with Vitocom 100

03 with main PCB VGL 10 and
variable speed heating circuit
pump
(13) additionally with Vitocom 100

06 with basic PCB VGL 10 and
extension kit for one heating
circuit with mixer*¹
(16) additionally with Vitocom 100

07 with basic PCB VGL 10,
extension kit for one heating
circuit with mixer*¹ and variable
speed heating circuit pump
(17) additionally with Vitocom 100

*¹The system only recognises the
extension kit if it is connected via the
KM BUS.

Not if connected via the 2-wire
Viessmann BUS.

Scanning temperatures

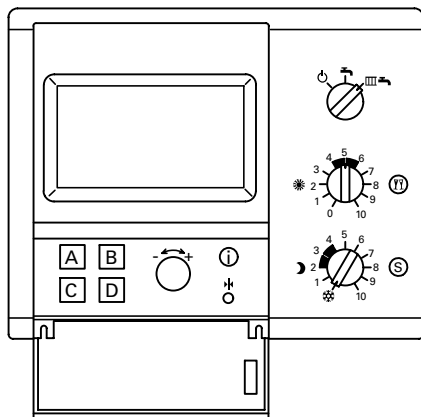

The following set and actual values can be scanned in the display of the Comfortrol programming unit:

- Outside temperature
- Boiler water temperature
- Flow temperature of the extension kit for the heating circuit with mixer
- Room temperature (if the Comfortrol programming unit together with the wall mounting fixture is used as remote control).

Open flap:

Menu item	Key
→ HEATING	
CIRCUIT A or	A
HEATING	
CIRCUIT B or	B
SYSTEM	D
→ OPERATING STATE	C or B
→ CONTINUE	A

- DHW temperature

Open flap:

Menu item	Key
→ DHW	C
→ CYLINDER	A
→ OPERATING STATE	C

Connection and wiring diagrams – Internal assemblies

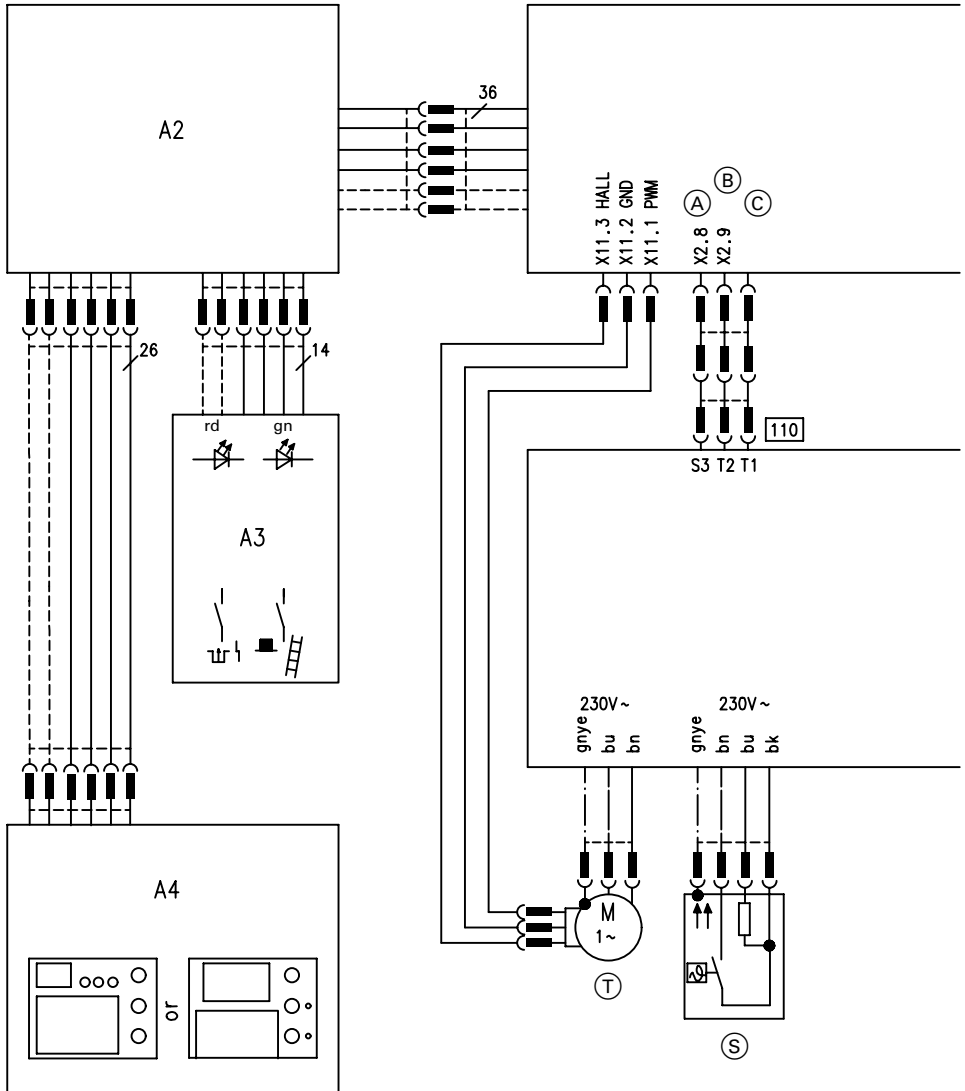

Connection and wiring diagrams – Internal assemblies (cont.)

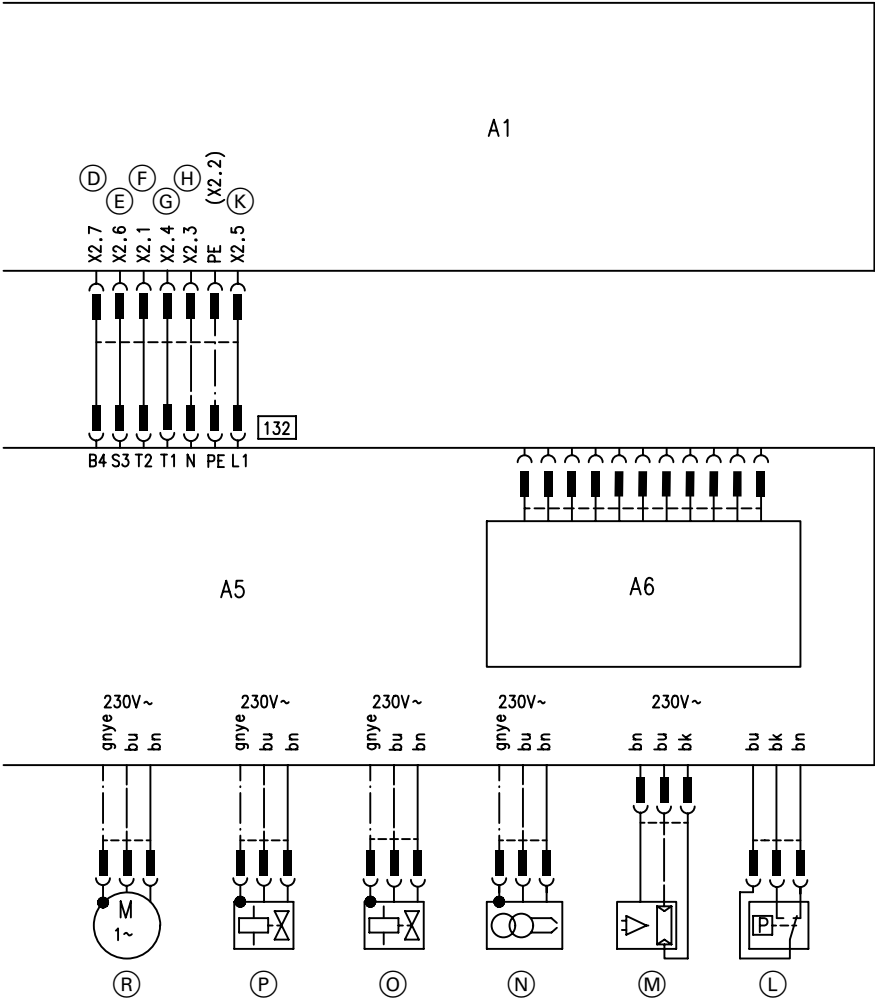

Connection and wiring diagrams – Internal assemblies (cont.)

- A1 Main PCB VGL 10
- A2 Adaptor PCB (in the front frame)
- A3 Optolink PCB
- A4 User interface
- A5 Plug mounting bracket
- A6 Oil burner control unit LMO 54

- Ⓐ Reset
- Ⓑ Burner demand
- Ⓒ Neutral conductor
- Ⓓ Fault
- Ⓔ Oil pre-heater
- Ⓕ Air pressure switch feedback
- Ⓖ Fuel valve 2
- Ⓗ Demand stage 2
- Ⓚ Fuel valve 1
- Ⓛ Air pressure switch 2.5 mbar
- Ⓜ Flame monitoring
- Ⓝ Ignition
- Ⓞ Fuel valve stage 2
- Ⓟ Fuel valve stage 1
- Ⓡ Oil pump
- Ⓢ Oil pre-heater
- Ⓣ Fan

Connection and wiring diagram – Main PCB VGL 10

A1 Main PCB VGL 10

- Ⓐ Control unit VR 20 (as delivered condition)
 - Ⓑ Boiler temperature sensor
 - Ⓒ Three-way valve
 - Ⓓ KM-BUS
 - Ⓔ Circulation pump
 - Ⓕ STB 100 °C; TW 82 °C
 - Ⓖ Mains input 230 V~, 50 Hz
 - Ⓗ Mains output for accessories 230 V~, 3 A
 - Ⓚ Flow temperature sensor (low loss header)
 - Ⓛ Cylinder temperature sensor
 - Ⓜ Outside temperature sensor
 - Ⓝ Programming unit with wall mounting base
- or
- Ⓞ External boiler blocking (Reposition strapping plug X6 to VR 20)
 - Ⓟ Vitotronic 050
or
Vitocom 200/300*¹
 - Ⓠ or
Solar control unit*¹
 - Ⓡ or
Extension kit for one heating circuit with mixer and/or Vitocom 100
 - Ⓢ Connection DHW circulation pump via adaptor (accessory)
 - Ⓣ Connection central fault messaging via adaptor (accessory)
 - Ⓤ External operating mode changeover or external demand (on site)*², *³
 - Ⓡ WS/RS remote control unit (accessory)
 - ① Internal connections
 - ② External connections

*¹Communication module required.

*²If making this connection, remove jumper X4.1 - X4.2.

*³Observe the coding address settings.

Connection and wiring diagram – Main PCB VGL 10 (cont.)

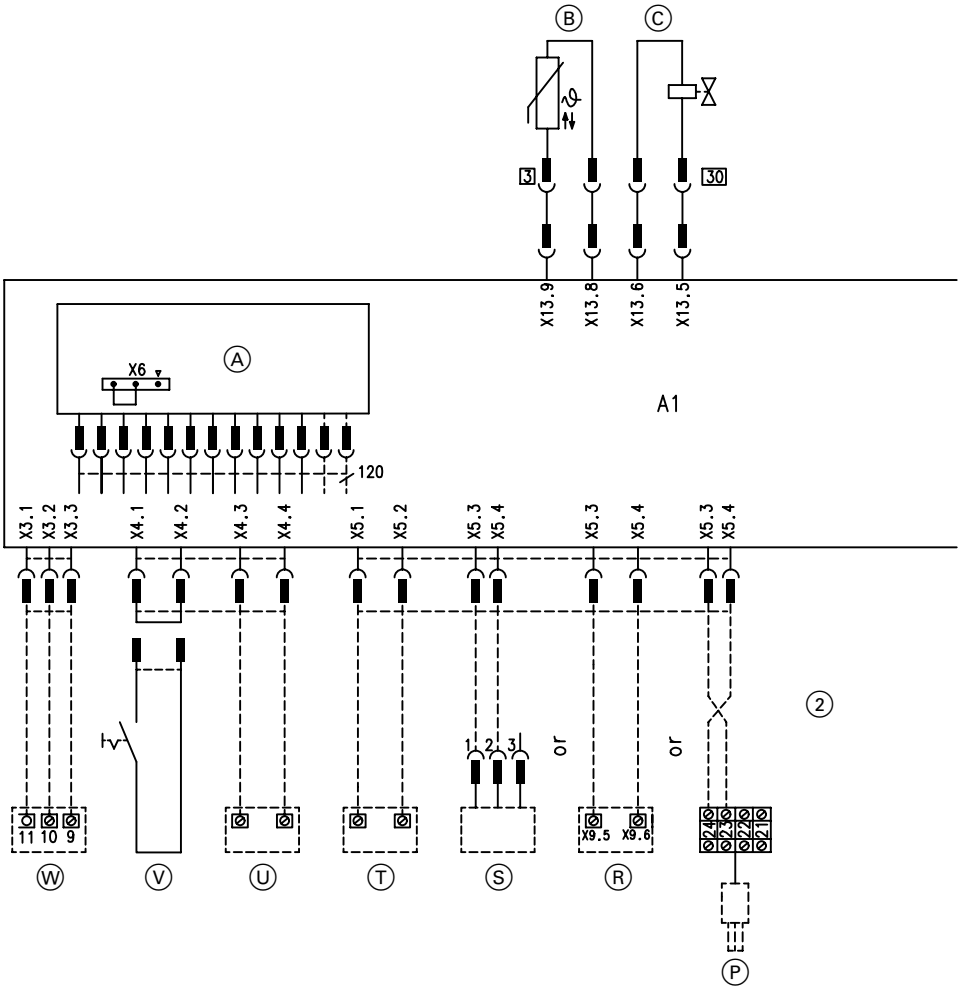

Connection and wiring diagram – Main PCB VGL 10 (cont.)

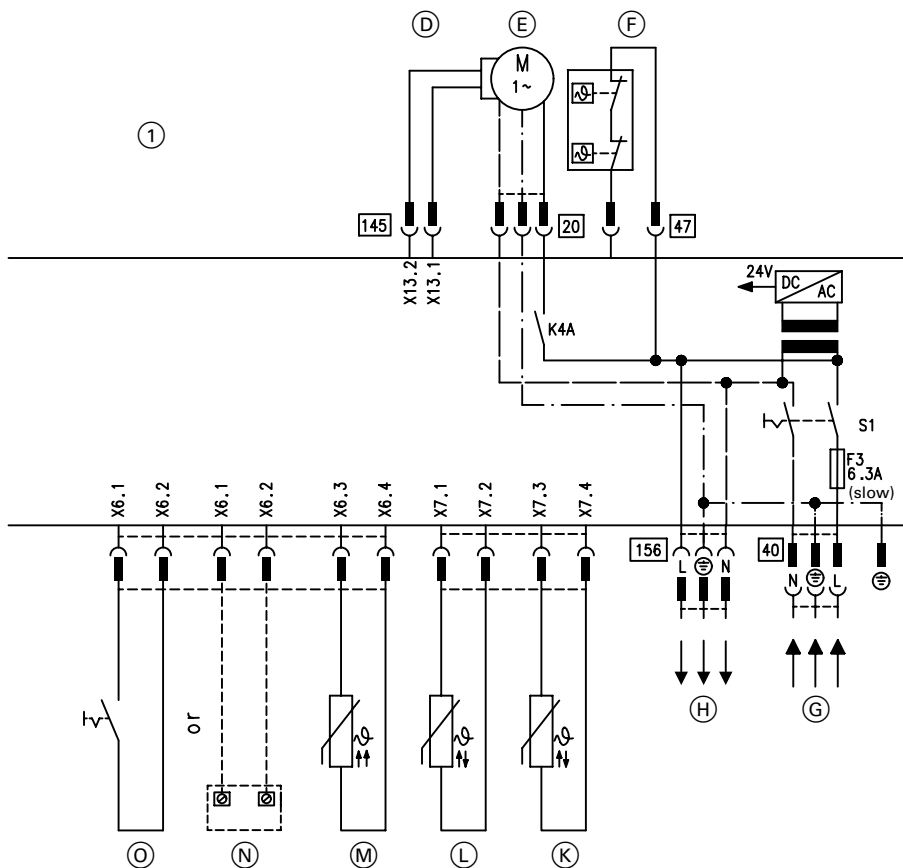

Parts list

When ordering spare parts

Quote the type and serial no. (see type plate) and the item no. of the required part (as per parts list). Obtain common parts from your local supplier.

Parts

- 002 Adaptor pipe and metering ring
- 003 Oil pump motor
- 004 Oil pump
- 005 Oil preheater
- 007 Fan
- 008 Air pressure switch
- 009 Fan gasket
- 011 Flame monitor
- 012 Retainer
- 013 Thermal insulation ring
- 014 Swirl equipment
- 015 Plug-in panel
- 016 Automatic oil combustion unit
- 017 Oil hose
- 018 Ignition cable set
- 019 Ignition module
- 020 Oil hose – return
- 021 Oil hose – flow
- 022 Solenoid coil
- 026 Silencer
- 027 Air inlet channel
- 032 Spray cover
- 034 Angled nozzle
- 035 Gasket pack
- 048 Control unit cover
- 050 Sensor clip
- 051 Tension bolt, spiral heat exchanger
- 052 Tension nut, spiral heat exchanger
- 053 Flow pipework
- 054 Return pipe
- 055 Hose seal
- 056 Flue gas gasket
- 057 Front panel
- 058 Flap cover with lock
- 059 Label pack
- 060 L.h. thermal insulating shell
- 061 R.h. thermal insulating shell
- 062 Rear thermal insulating shell
- 064 Quick-acting air vent valve
- 065 Siphon
- 066 Condensate hose
- 067 Siphon hose bend
- 068 Pump motor
- 069 Gasket pack
- 071 Grub screw M 6
- 072 Diverter valve
- 073 Pressure gauge
- 074 Boiler adaptor
- 075 Wall mounting frame
- 076 Temperature sensor
- 077 Retaining spring pack
- 078 Electro-magnetic drive
- 140 Hinged flap for standard programming unit
- 141 Programming module
- 142 Mounting plate
- 143 Cable gland cover
- 144 Connection module cover
- 145 PCB cover VR 20
- 146 Connection module
- 147 Mounting bracket
- 148 Cable gland plug
- 150 Cable entry strip
- 153 Rocker switch
- 154 Main ON/OFF button
- 155 Dummy cover
- 156 Optolink PCB
- 157 Adaptor PCB
- 158 Main PCB VGL 10
- 159 PCB VR 20
- 165 High limit safety cut-out
- 166 Temperature limiter
- 171 Ribbon cable 26 pole
- 174 Fuse 6.3 A (slow)
- 175 Standard programming unit
- 177 Comfortrol programming unit
- 179 Pressure gauge seat
- 200 Locking bracket
- 201 Outside temperature sensor

Parts list (cont.)

070 Small parts comprising:

- 70a Threaded stud M 8 × 16
- 70b Hexagon nut M 8
- 70d Cheese-head screw M 5 × 16
- 70e Cheese-head screw M 4 × 10
- 70f Serrated washer A 4.3
- 70g Cheese-head screw M 6 × 20
- 70h Washer A 6.4
- 70i Cheese-head screw M 5 × 12
- 70j Cheese-head screw M 5 × 8
- 70k Cheese-head screw M 4 × 28
- 70l Cheese-head screw M 5 × 40
- 70m Cheese-head screw M 3 × 6
- 70n Seal washer A 5.5 × 12 × 2
- 70o Washer A 5.3
- 70p Lock washer 5
- 70q Cheese-head screw M 5 × 35
- 70r Gasket A 10 × 14 × 1.5
- 70s Ball screw
- 70t Countersunk screw M 4 × 8

Parts not shown

- 028 Filter element SIKU 2
(25-40 µm), standard
- 029 Magnum filter bowl
- 030 Filter element SIKU (25-40 µm),
for item 029
- 080 Installation instructions
- 081 Service instructions
- 082 Spray paint, pure white
- 083 Paint stick, pure white
- 084 Operating instructions for
weather-compensated mode
with standard programming unit
- 085 Operating instructions for
weather-compensated mode with
Comfortrol programming unit
- 086 Maintenance set
- 090 Neutralising system
maintenance set, comprising:
Granulate bag and charcoal filter
- 152 Female connector for control unit
- 160 Connecting cable plug [132](#)
- 161 Cable loom X11/X13, motor
electronics/KM BUS pump
- 162 Connecting cable plug [110](#)
- 178 The control unit pack comprises:
Strain relief, cable gland and
plug [156](#)

Wear parts

- 001 Flame tube
- 006 Nozzle
- 010 Ignition electrode block
- 023 Plug-in coupler
- 024 Filter cartridge for item 004
- 025 Pack
- 031 Cleaning brush
- 087 Seal ring

- Ⓐ Type plate,
optionally l.h. or r.h. side

Parts list (cont.)

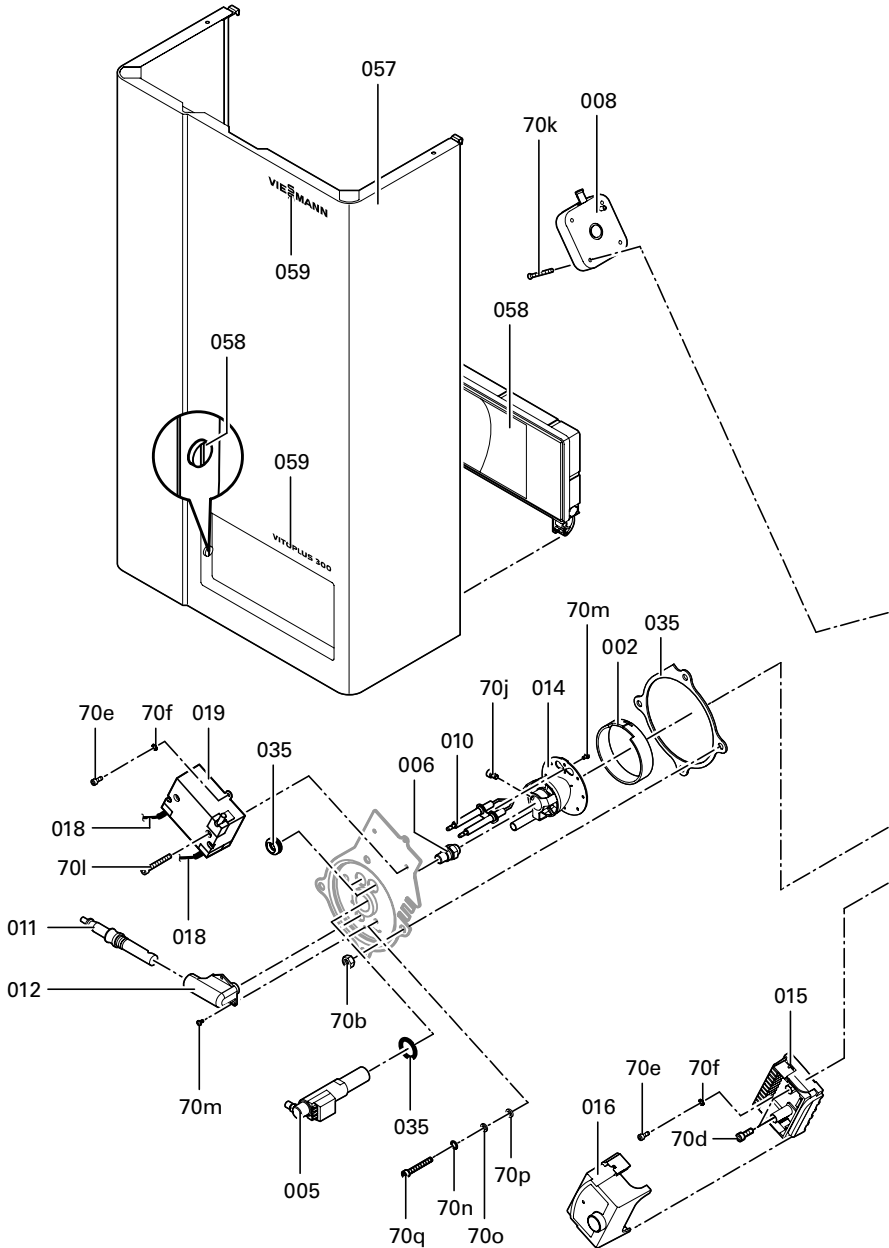

Parts list (cont.)

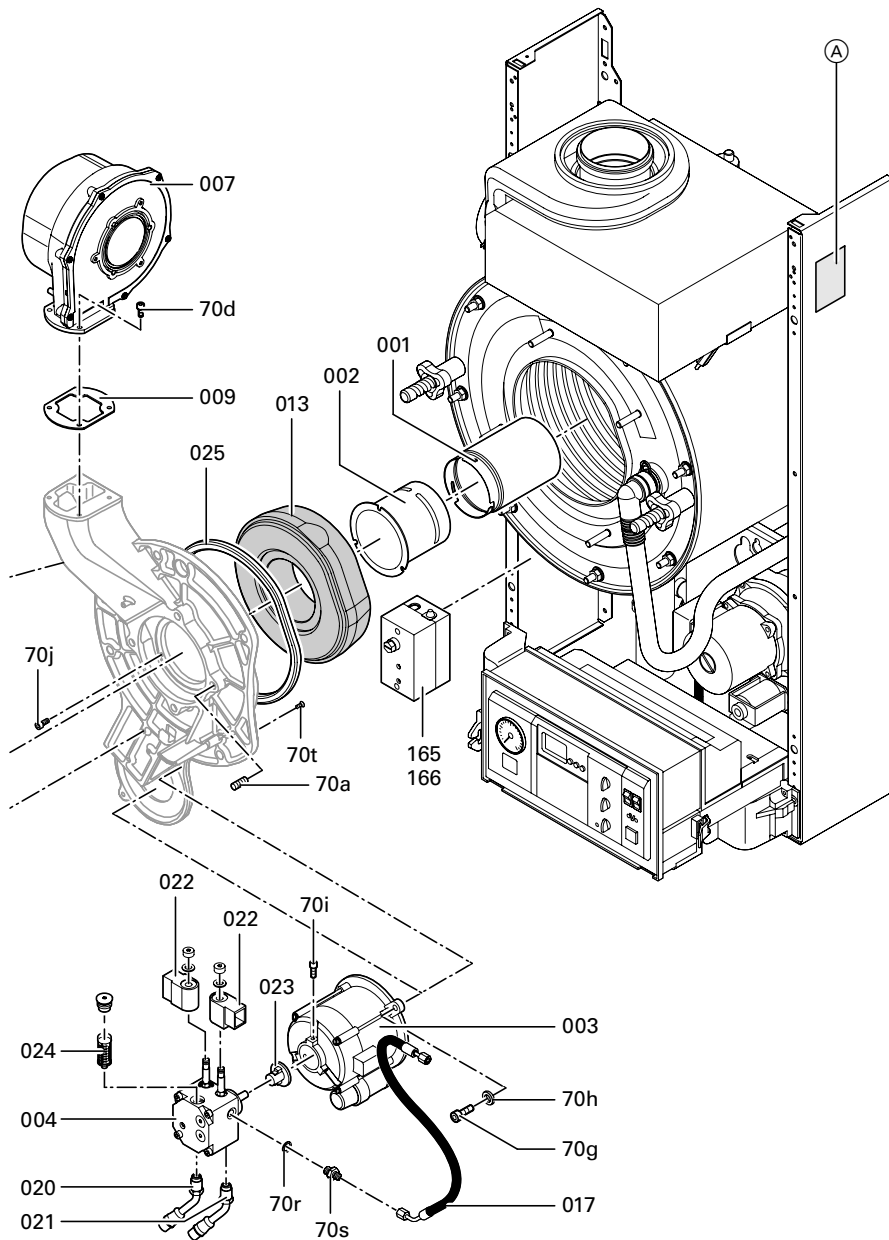

5692 502 GB

Parts list (cont.)

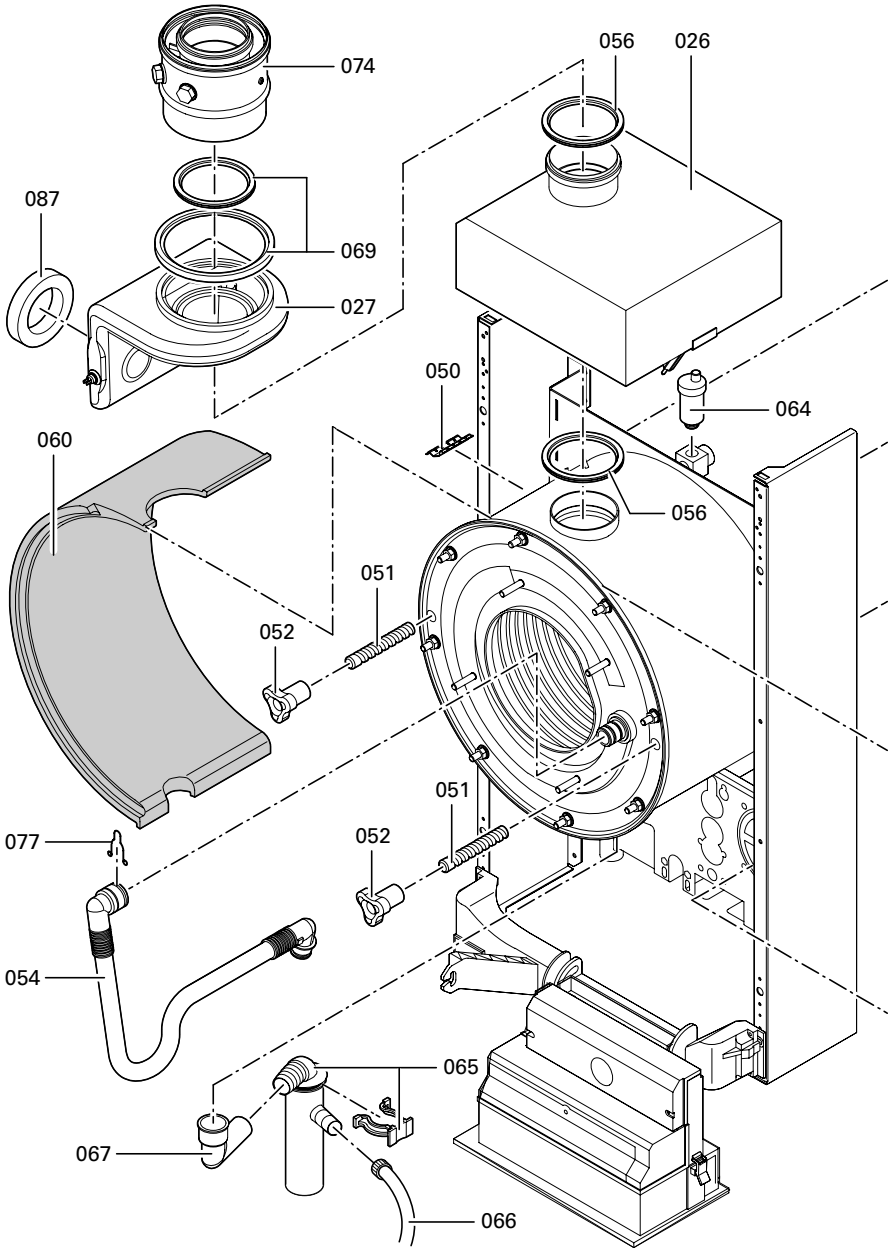

Parts list (cont.)

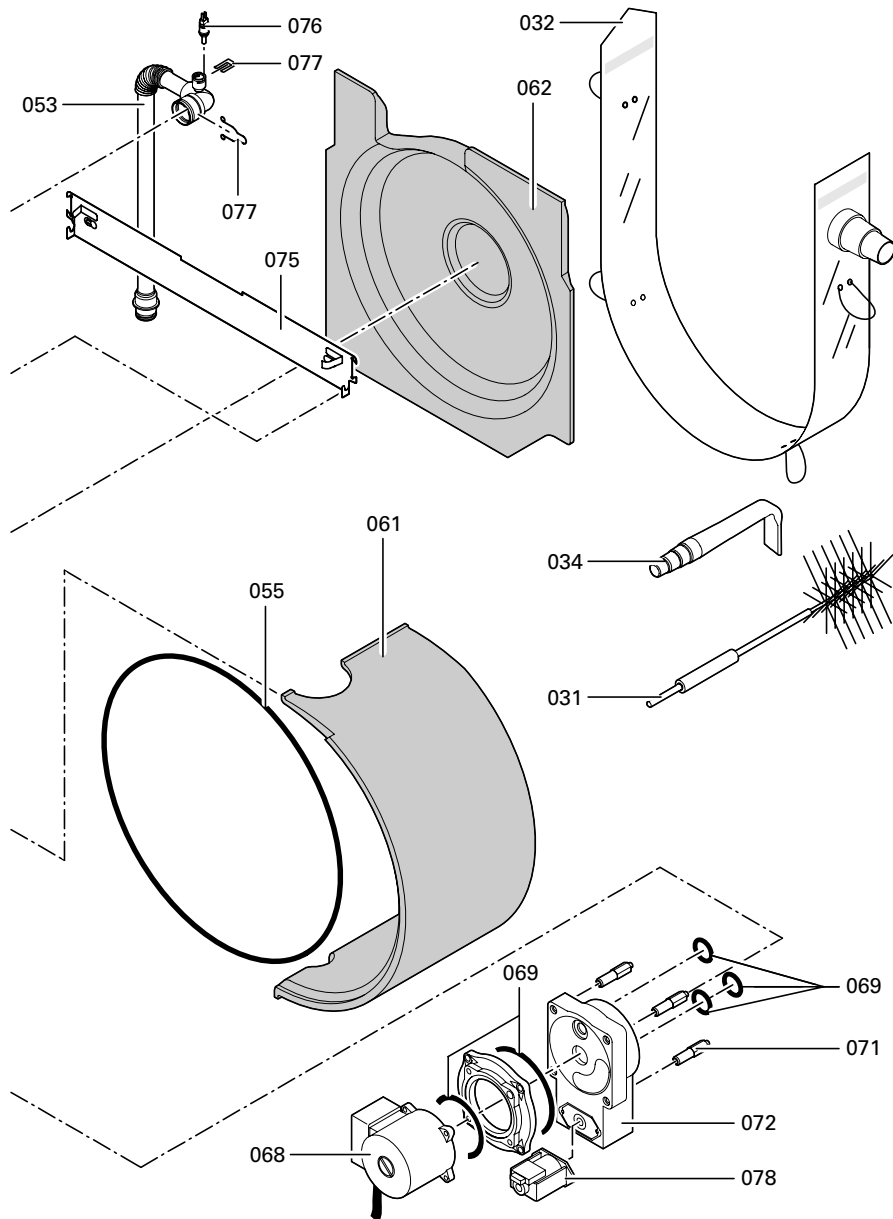

Parts list (cont.)

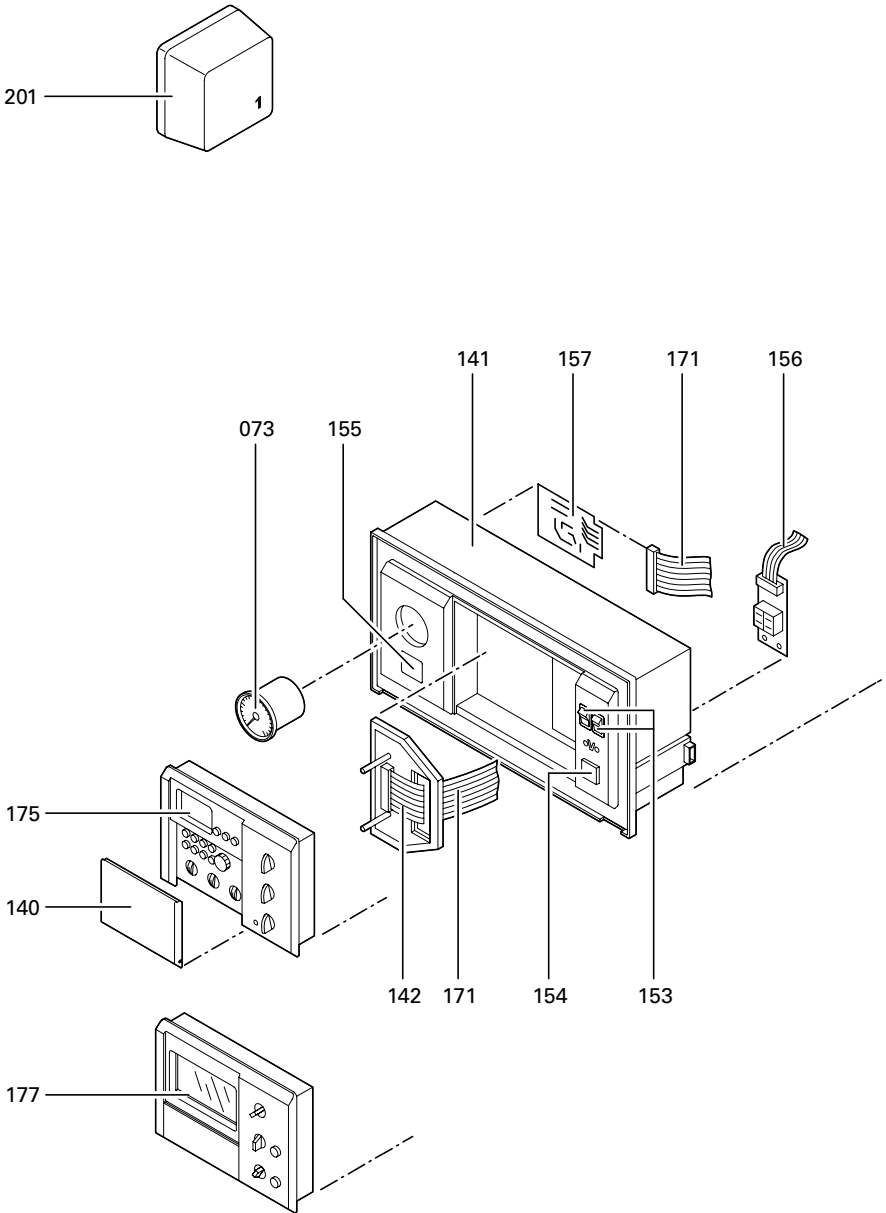

Parts list (cont.)

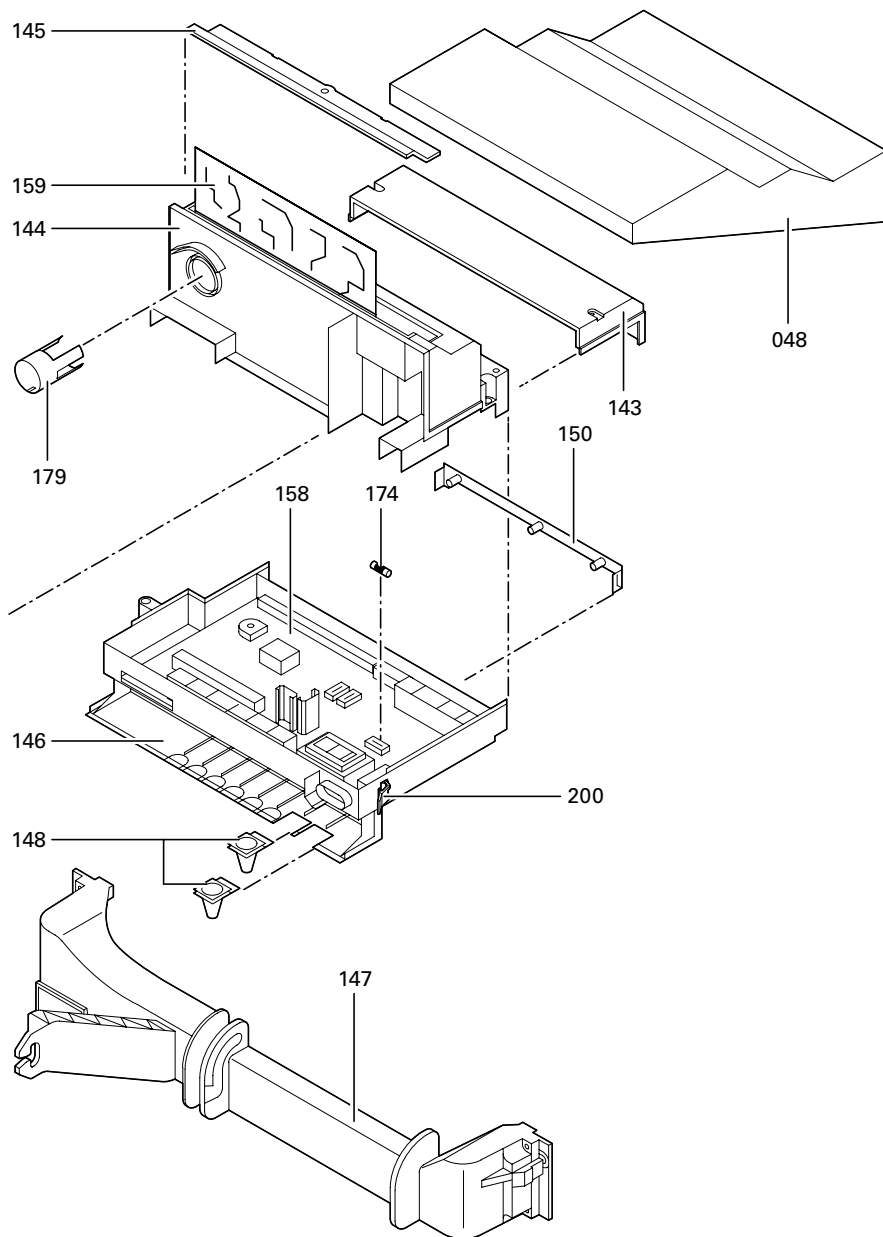

Commissioning/service report

Setting and test values				Initial start-up
			Date:	
			By:	
Oil pressure	Stage 1	actual	<i>bar</i>	
		set	<i>bar</i>	
	Stage 2	actual	<i>bar</i>	
		set	<i>bar</i>	
Vacuum		actual	<i>bar</i>	
		after maintenance	<i>bar</i>	
Carbon dioxide content CO₂	Stage 1	actual	<i>% by vol.</i>	
		set	<i>% by vol.</i>	
	Stage 2	actual	<i>% by vol.</i>	
		set	<i>% by vol.</i>	
or				
Oxygen content O₂	Stage 1	actual	<i>% by vol.</i>	
		set	<i>% by vol.</i>	
	Stage 2	actual	<i>% by vol.</i>	
		set	<i>% by vol.</i>	
Carbon monoxide content CO	Stage 1	actual	<i>ppm</i>	
		set	<i>ppm</i>	
	Stage 2	actual	<i>ppm</i>	
		set	<i>ppm</i>	
Stat. burner pressure (operating phase)	Stage 1	actual	<i>mbar</i>	
		set	<i>mbar</i>	
	Stage 2	actual	<i>mbar</i>	
		set	<i>mbar</i>	



Maint./service **Maint./service** **Maint./service** **Maint./service**

5692 502 GB

Commissioning/service report (cont.)

Setting and test values				Maint./service
			Date:	
			By:	
Oil pressure	Stage 1	actual	<i>bar</i>	
		set	<i>bar</i>	
	Stage 2	actual	<i>bar</i>	
		set	<i>bar</i>	
Vacuum		actual	<i>bar</i>	
		after maintenance	<i>bar</i>	
Carbon dioxide content CO₂	Stage 1	actual	<i>% by vol.</i>	
		set	<i>% by vol.</i>	
	Stage 2	actual	<i>% by vol.</i>	
		set	<i>% by vol.</i>	
or				
Oxygen content O₂	Stage 1	actual	<i>% by vol.</i>	
		set	<i>% by vol.</i>	
	Stage 2	actual	<i>% by vol.</i>	
		set	<i>% by vol.</i>	
Carbon monoxide content CO	Stage 1	actual	<i>ppm</i>	
		set	<i>ppm</i>	
	Stage 2	actual	<i>ppm</i>	
		set	<i>ppm</i>	
Stat. burner pressure (operating phase)	Stage 1	actual	<i>mbar</i>	
		set	<i>mbar</i>	
	Stage 2	actual	<i>mbar</i>	
		set	<i>mbar</i>	



Maint./service | **Maint./service** | **Maint./service** | **Maint./service**

5692 502 GB

Commissioning/service report (cont.)

Setting and test values				Maint./service
			Date:	
			By:	
Oil pressure	Stage 1	actual	<i>bar</i>	
		set	<i>bar</i>	
	Stage 2	actual	<i>bar</i>	
		set	<i>bar</i>	
Vacuum		actual	<i>bar</i>	
		after maintenance	<i>bar</i>	
Carbon dioxide content CO₂	Stage 1	actual	<i>% by vol.</i>	
		set	<i>% by vol.</i>	
	Stage 2	actual	<i>% by vol.</i>	
		set	<i>% by vol.</i>	
or				
Oxygen content O₂	Stage 1	actual	<i>% by vol.</i>	
		set	<i>% by vol.</i>	
	Stage 2	actual	<i>% by vol.</i>	
		set	<i>% by vol.</i>	
Carbon monoxide content CO	Stage 1	actual	<i>ppm</i>	
		set	<i>ppm</i>	
	Stage 2	actual	<i>ppm</i>	
		set	<i>ppm</i>	
Stat. burner pressure (operating phase)	Stage 1	actual	<i>mbar</i>	
		set	<i>mbar</i>	
	Stage 2	actual	<i>mbar</i>	
		set	<i>mbar</i>	



Maint./service | **Maint./service** | **Maint./service** | **Maint./service**

5692 502 GB

Specification

Rated voltage:	230 V~	Temperature limiter setting:	82 °C
Rated frequency:	50 Hz	Setting	
Rated current:	4 A~	High limit	
Safety class:	I	safety cut-out:	100 °C (fixed)
Protection level:	IP 20	Line fuse (mains):	max. 16 A
Permissible ambient temperature			
■ in use:	0 to +40 °C		
■ during storage and transport:	-20 to +65 °C		

Oil fired condensing boiler, type B₂₃, C_{33x}, C_{53x}, C_{63x}

Rated output	kW	12.9/19.3		16.1/23.5	
Burner stage		Stage 1	Stage 2	Stage 1	Stage 2
Rated output at burner stage	kW	12.9	19.3	16.1	23.5
Power consumption incl. circulation pump	W	205	255	218	280
Motor speed Oil pump drive	min ⁻¹	2880		2880	
Pump capacity Oil pump	l/h	45		45	
Burner version		Two stage		Two stage	
Product ID		CE-0645 BM 112.1			

Product characteristics (to EnEV)

Rated output range for central heating	kW	12.9/19.3		16.1/23.5	
Efficiency η at					
- 100% of rated output	%		96.1		96.0
- 30% of rated output	%		103.7		103.5
Standby losses $q_{B,70}$ *1	%		1.27		1.10
Power consumption *1 at					
- 100% of rated output	W		180		198
- 30% of rated output	W		60		66

*1 Max. limit to EnEV.

Declaration of conformity for Vitoplus 300

We, Viessmann Werke GmbH&Co KG, D-35107 Allendorf, declare as sole responsible body, that the product

Oil fired condensing boiler Vitoplus 300

conforms to the following standards:	This product is identified in accordance with the following directives:
DIN 4702-7	73/ 23/EEC
EN 625	89/336/EEC
EN 677	92/ 42/EEC
EN 267	98/ 37/EC
EN 303	
EN 483	
EN 60 335	
EN 50 165	as follows:
EN 55 014	
EN 61 000-3-2	CE
EN 61 000-3-3	
prEN 13 203 (draft Sept. 2000)	

This product meets the requirements of the Efficiency Directive (92/42/EEC) for:

Low temperature boilers

The **product characteristics** determined as system values for **Vitoplus 300 as part of EC type testing according to the Efficiency Directive** (see specification table) can be utilised to assess the energy consumption of heating and ventilation equipment to DIN V 4701-10 which is specified by the EnEV.

Allendorf, 5 February 2003

Viessmann Werke GmbH&Co KG



pp. Manfred Sommer

Manufacturer's certificate according to the 1st BImSchV

We, Viessmann Werke GmbH&Co KG, D-35107 Allendorf, confirm that the following product meets the NO_x limits specified by the 1st BImSchV §7 (2):

Oil fired condensing boiler Vitoplus 300

Allendorf, 5 February 2003

Viessmann Werke GmbH&Co KG

A handwritten signature in black ink, appearing to read 'M. Sommer', with a long horizontal stroke extending to the right.

pp. Manfred Sommer

Keyword index

A

Air volume adjustment, 11

B

Boiler control unit, checking
 ■ with Comfortrol prog. unit, 51
 ■ with standard prog. unit, 50
 Boiler temperature sensor, 45
 Boiler water temperature scanning, 75, 93
 Brief scan, 74, 92
 Burner cleaning, 13
 Burner control unit, LMO 54, 26
 Burner removal, 17

C

Cleaning combustion chamber, 18
 CO₂ adjustment, 8
 Coding addresses, calling up (with Comfortrol prog. unit), 82
 Coding address overview (with Comfortrol prog. unit), 82
 Coding level 1 call-up (with standard programming unit), 59
 Coding level 1 overview (with standard programming unit), 64
 Coding level 2 call-up (with standard programming unit), 69
 Coding level 2 overview (with standard programming unit), 70
 Combustion chamber cleaning, 18
 Commissioning/service report, 108
 Condensate drain, 20
 Connection and wiring diagrams
 ■ Internal assemblies, 94
 ■ Main PCB VGL 10, 97
 Cylinder temperature sensor, 45
 Cylinder water temperature scanning, 75, 93

D

Declaration of conformity, 115
 Diagnostics, burner, 26
 Diagnostics, control unit, 34
 Diaphragm expansion vessel, 21
 Display on the burner control unit, 27

E

Electrode block, 14
 Expansion vessel, 21
 Extension kit for one heating circuit with mixer, 49
 Extension module, Viessmann 2-wire BUS, 50
 ■ with Comfortrol prog. unit, 51
 ■ with standard prog. unit, 50
 External demand, 53
 External heating program changeover, 55
 Externally blocked burner, 54

F

Fault messages
 ■ Burner, 29
 ■ Control unit, 34
 Flame monitor checking, 12
 Flue gas test port, 8
 Fuel oil filter, 4
 Fuse, 48

H

Heating curve
 ■ with Comfortrol prog. unit, 80
 ■ with standard prog. unit, 60
 Heating surfaces, cleaning, 18
 Heating system designs, 22
 High limit safety cut-out, 48

Keyword index (cont.)

I

Ignition, 26
Ignition electrodes setting, 14
Initial start-up, 4

L

Language selection, 7
Low loss header, 24, 25

M

Mains supply, 97
Manufacturer's certificate, 116

N

Neutralising system, 20
Nozzle replacement, 14
Nozzle size, 8

O

Oil burner nozzle, 8, 14
Oil pressure, 8, 10
Oil pressure adjustment, 10
Oil pump, 10
Oil pump filter cleaning, 16
Outside temperature, scanning, 75, 93
Outside temperature sensor, 44

P

Parts list, 100
PCB VR 20, 53, 54
Power supply connection, 94, 97
Program sequence, 26

R

Relay test, 46, 47

S

Safety instructions, 2
Screed drying, 64, 84
Serial numbers, 2
Siphon, 20
Specification, 114
Standard values, burner settings, 8
Static burner pressure, 8, 11

T

Temperature scanning
■ with Comfortrol prog. unit, 93
■ with standard prog. unit, 75
Test port, 8
Troubleshooting, 30

V

Vacuum checking, 10
Validity of this manual, 2
Vitotronic 050 checking, 50
■ with Comfortrol prog. unit, 51
■ with standard prog. unit, 50

W

Wiring diagram, 94

Viessmann Werke GmbH & Co
D-35107 Allendorf
Tel: +49 6452 70-0
Fax: +49 6452 70-27 80
www.viessmann.de

Viessmann Limited
Hortonwood 30, Telford
Shropshire, TF1 7YP, GB
Tel: +44 1952 675000
Fax: +44 1952 675040
E-mail: info-uk@viessmann.com

5692 502 GB Subject to technical modifications.

 Printed on environmentally friendly,
chlorine-free bleached paper