

Replacing burner components

Cylinder burner
Natural gas E, LL and LPG P
for the Vitocrossal 200, type CM2
Rated heating output 400 to 620 kW

Replacing burner components



Safety instructions



Please follow these safety instructions closely to prevent accidents and material losses.

Safety instructions explained



Danger

This symbol warns against the risk of injury.

Note

Details identified by the word "Note" contain additional information.



Please note

This symbol warns against the risk of material losses and environmental pollution.

Target group

These instructions are exclusively intended for authorised contractors.

- Work on gas installations must only be carried out by a registered gas fitter.
- Work on electrical equipment must only be carried out by a qualified electrician.

Regulations to be observed

- National installation regulations
- Statutory regulations for the prevention of accidents
- Statutory regulations for environmental protection
- Codes of practice of the relevant trade associations
- All current safety regulations as defined by DIN, EN, DVGW, TRGI, TRF, VDE and all locally applicable standards
 - Ⓐ ÖNORM, EN, ÖVGW-TR Gas, ÖVGW-TRF and ÖVE
 - ⒸH SEV, SUVA, SVGW, SVTI, SWKI, VKF and EKAS guideline 1942: LPG, part 2

Working on the system

- Isolate the system from the power supply (e.g. by removing the separate fuse or by means of a mains isolator) and check that it is no longer 'live'.
- Safeguard the system against reconnection.
- Where gas is used as the fuel, close the main gas shut-off valve and safeguard it against unintentional reopening.

Index

1. Information	Disposal of packaging	4
	Symbols	4
2. Installation sequence	Preparing to replace components	5
	Burner control unit VUC 310	6
	Coding card on burner control unit VUC 310	7
	Display and programming unit of burner control unit VUC 310	8
	Gas train	9
	Air pressure switch	10
	Ignition unit	11
	Ignition cables	11
	Ignition electrodes	12
	Ionisation electrode	13
	Fan	14
	Rotary damper and servomotor	15
	Burner gauze assembly	16
	Further assembly and commissioning	19

Disposal of packaging









Please dispose of packaging waste in line with statutory regulations.

DE: Use the disposal system organised by Viessmann.

AT: Use the ARA statutory disposal system (Altstoff Recycling Austria AG, licence number 5766).

CH: Packaging waste is disposed of by the HVAC contractor.

Symbols

Symbol	Meaning
	Reference to other document containing further information
	Step in a diagram: The numbers correspond to the order in which the steps are carried out.
	Warning of material losses and environmental pollution
	Live electrical area
	Pay particular attention.
	<ul style="list-style-type: none"> ▪ Component must audibly click into place. or ▪ Acoustic signal
	<ul style="list-style-type: none"> ▪ Fit new component. or ▪ In conjunction with a tool: Clean the surface.
	Dispose of component correctly.
	Dispose of component at a suitable collection point. Do not dispose of component in domestic waste.

Preparing to replace components

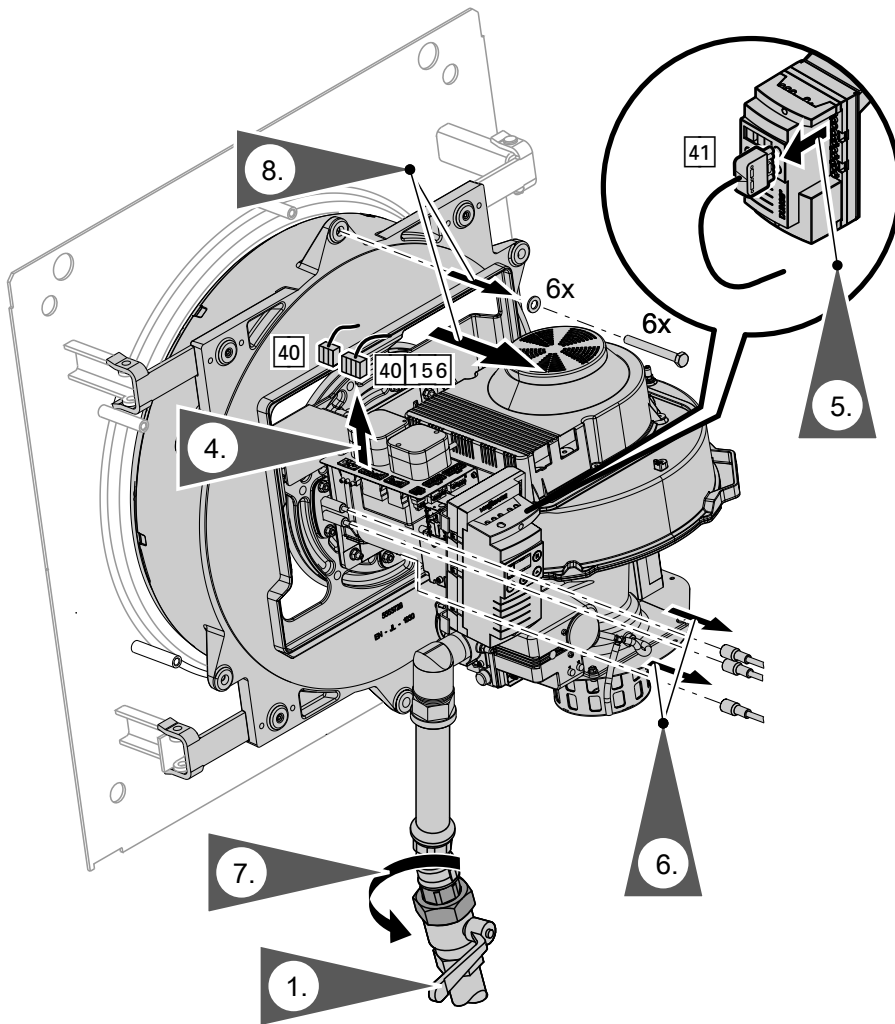

Fig. 1

1. Close the gas shut-off valve.
2. Switch off mains isolator (outside the installation room).
3. Remove front panels, the front top panel and the side panel (from the side where the boiler door is hung).
4. Pull plug 40, 40/156 from the plug-in panel.
5. Pull plug 41 from the burner control unit.
6. Disconnect the plugs from the electrodes.
7. Undo the gas fitting.
8. Only if the burner gauze assembly, ignition electrodes or ionisation electrode are faulty: Pull all burner cables from the plug-in panel and the burner control unit. Undo 6 x M 12 screws and open the boiler door.



Danger

Mains voltage can be life threatening. Isolate the burner from the power supply before working on the burner.

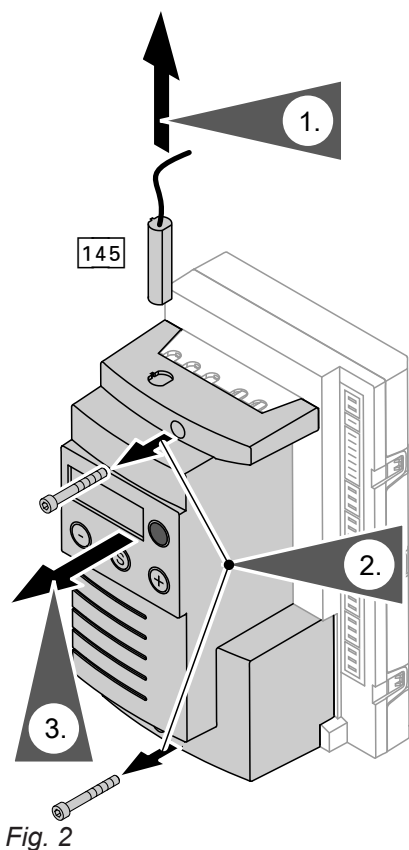

1. Pull KM BUS plug [145].
2. Undo 2 fixing screws.
Torque when installing: 1 Nm
3. Lift the display and programming unit and disconnect the plug of the burner control unit connecting cable.
Remove the display and programming unit.
4. Remove all connecting cables from the burner control unit.

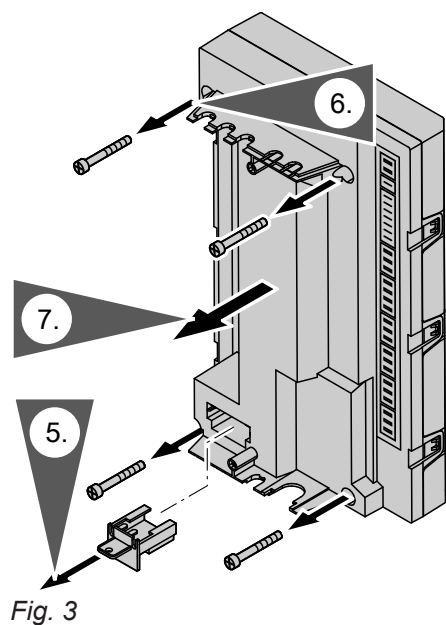

5. Pull the coding card from the burner control unit.
6. Undo 4 fixing screws on the burner control unit.
7. Remove the burner control unit.
8. Install the new burner control unit in reverse order.
9. For further steps see chapter "Further assembly" on page 19.

Coding card on burner control unit VUC 310

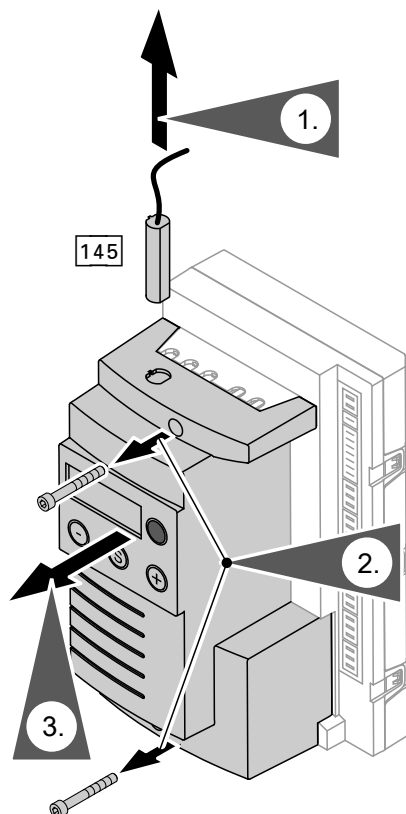

Fig. 4

1. Pull KM BUS plug 145.
2. Undo 2 fixing screws.
Torque when installing: 1 Nm
3. Lift the display and programming unit and disconnect the plug of the burner control unit connecting cable.
Remove the display and programming unit.

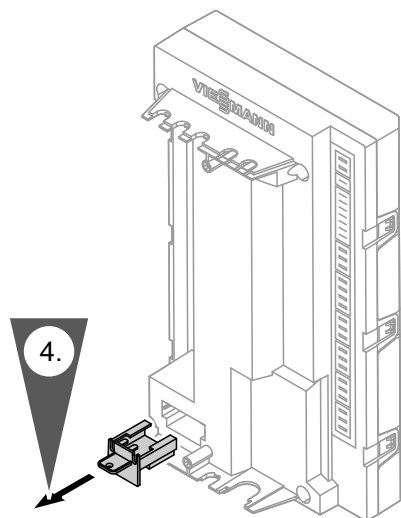

Fig. 5

4. Pull the coding card from the burner control unit.
5. Insert new coding card.
6. For further steps see chapter "Further assembly" on page 19.

Note

If fault code "F b7" is displayed, check the coding card.



Service instructions

Display and programming unit of burner control unit VUC 310

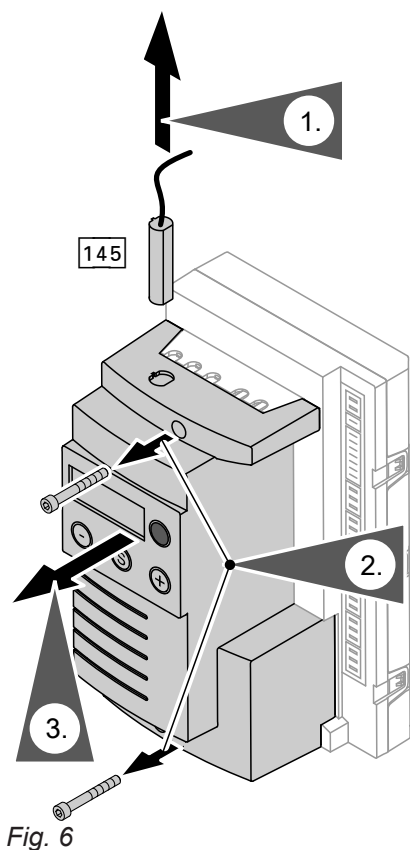

1. Pull KM BUS plug 145.
2. Undo 2 fixing screws.
Torque when installing: 1 Nm
3. Lift the display and programming unit and disconnect the plug of the burner control unit connecting cable.
Remove the display and programming unit.
4. Install new display and programming unit in reverse order.
5. For further steps see chapter "Further assembly" on page 19.

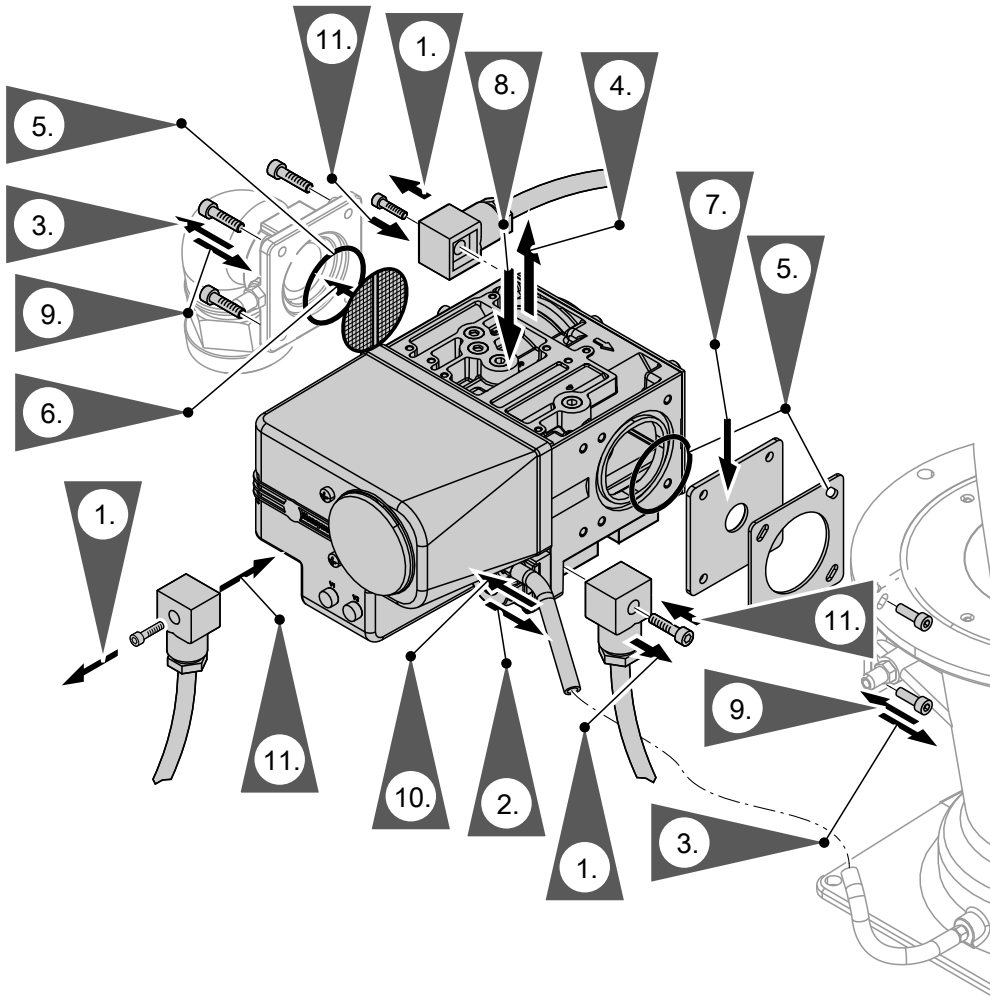

Fig. 7

1. Undo screws and pull plugs from the gas train and both gas pressure switches.
2. Pull the compensation line from the gas train.
3. Remove screws from flange.
4. Remove the gas train between the connection flanges on the Venturi pipe and on the gas supply pipe.
5. Replace the gaskets on the inlet and outlet sides.
6. Place the filter insert between the inlet flange and the gas train.
7. For natural gas E and LPG P:
Place the restrictor between the gas train and the gasket.
8. Position the gas train between the connection flanges on the Venturi pipe and on the gas supply pipe (observe the direction of installation).
9. Secure the gas train free from stress on the flange using screws.
Torque: 1.5 Nm
10. Connect the compensation line to the gas train.
11. Push the plugs onto the gas train and both gas pressure switches. Secure with 3 screws.

Note
Never interchange the connecting cables of the gas pressure switches (GDW 1 and GDW 2).

12. For further steps see chapter "Further assembly" on page 19.

Danger
Escaping gas leads to a risk of explosion.
Check the fitting for gas tightness.

Please note
The use of leak detection spray can result in faulty operation.
Leak detection spray must not come into contact with electrical contacts.

Air pressure switch

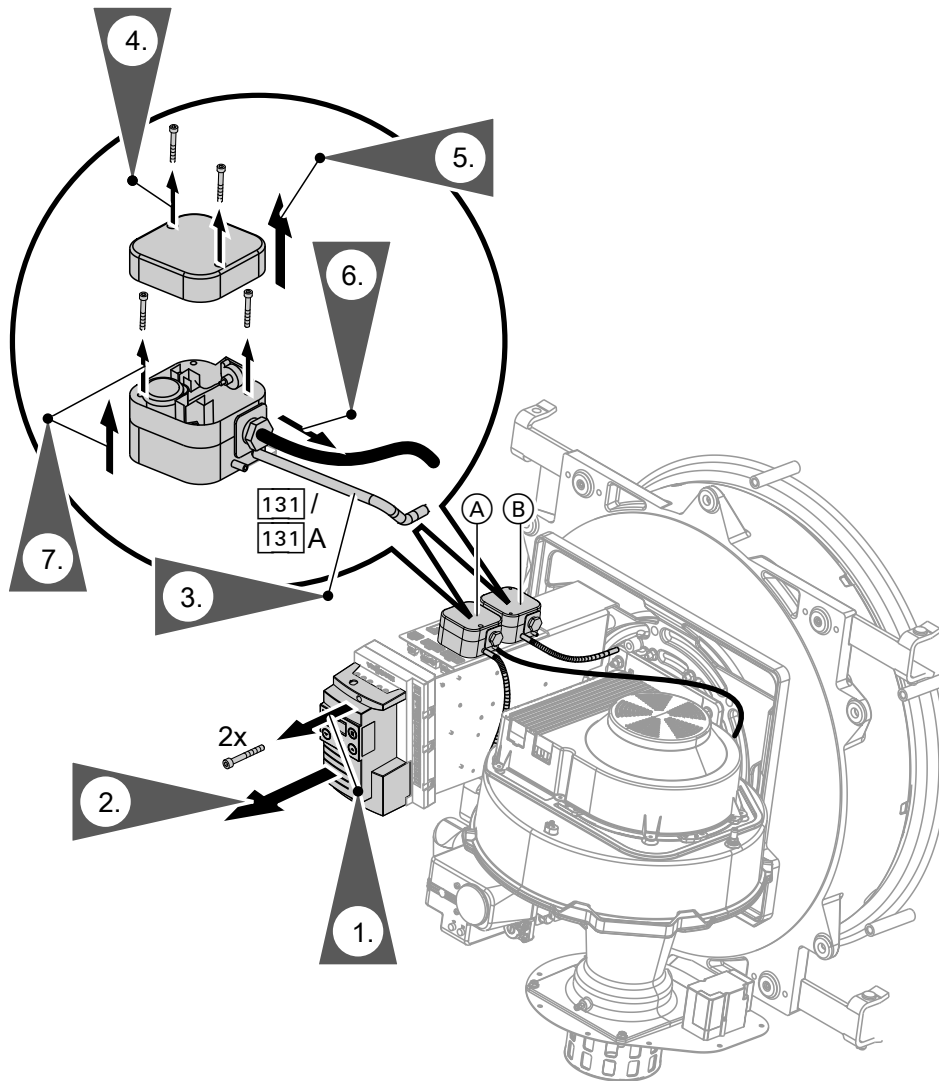

Fig. 8

- (A) Air pressure switch, fan (LDW1, connection hose on connector marked "-")
- (B) Air pressure switch, combustion chamber (LDW2, connection hose on connector marked "+")

1. Undo 2 fixing screws.
Torque when installing: 1 Nm
2. Remove the display and programming unit from the burner control unit.
3. Pull plug **131** (LDW1) and plug **131A** (LDW2) from the plug-in strip on the burner control unit.
4. Undo the fixing screws on the air pressure switch.
Torque when installing: 1 Nm
5. Remove the air pressure switch cover.
6. Pull the connection hose from the connector.
7. Undo the base fixing screws and remove the base.

8. Install new air pressure switch in reverse order.

Note

Attach the connection hose to the corresponding connector.

9. For further steps see chapter "Further assembly" on page 19.

Note

Set the new air pressure switch to exactly the same value as that of the replaced air pressure switch.

Air pressure switch settings

LDW1	set to 1 mbar ↓
LDW2	set to 5 mbar ↑

Ignition unit

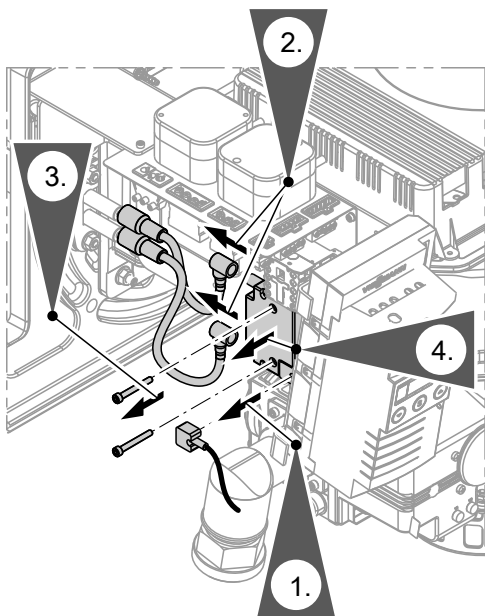

Fig. 9

1. Pull the connecting cable from the ignition unit.
2. Pull the ignition cables from the ignition unit.
3. Undo the ignition unit fixing screws.
Torque when installing: 1.5 Nm
4. Remove the ignition unit.
5. Install new ignition unit in reverse order.
6. For further steps see chapter "Further assembly" on page 19.

Ignition cables

1. Pull the ignition cables from the ignition unit.
2. Pull the ignition plugs from the ignition electrodes.
3. Install new ignition cables in reverse order.
4. For further steps see chapter "Further assembly" on page 19.

Ignition electrodes

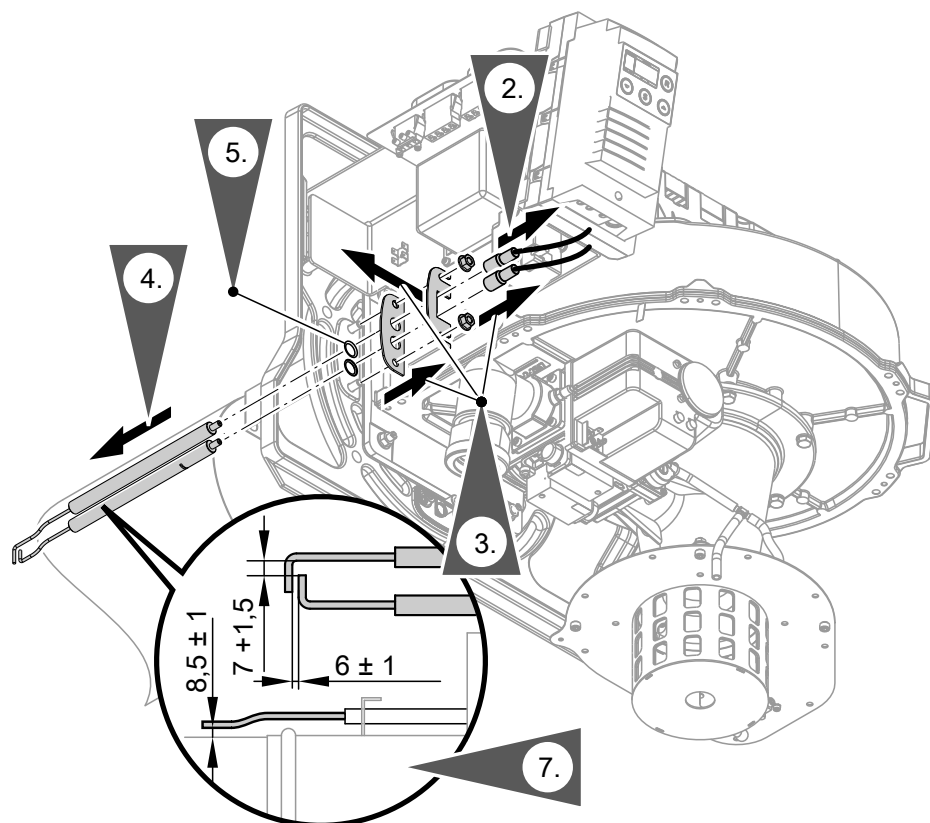

Fig. 10

1. Undo 6 x M 12 screws and open the boiler door.
2. Pull the ignition plugs from the ignition electrodes.
3. Undo 2 nuts on the centring plate and remove the centring plate and mounting plate.
Torque when installing: 4 Nm
4. Remove electrodes completely by pulling them forwards.
5. Replace O-rings.
6. Install new ignition electrodes in reverse order.
7. Check the adjustment dimensions of the electrodes and correct if required.
8. For further steps see chapter "Further assembly" on page 19.

Ionisation electrode

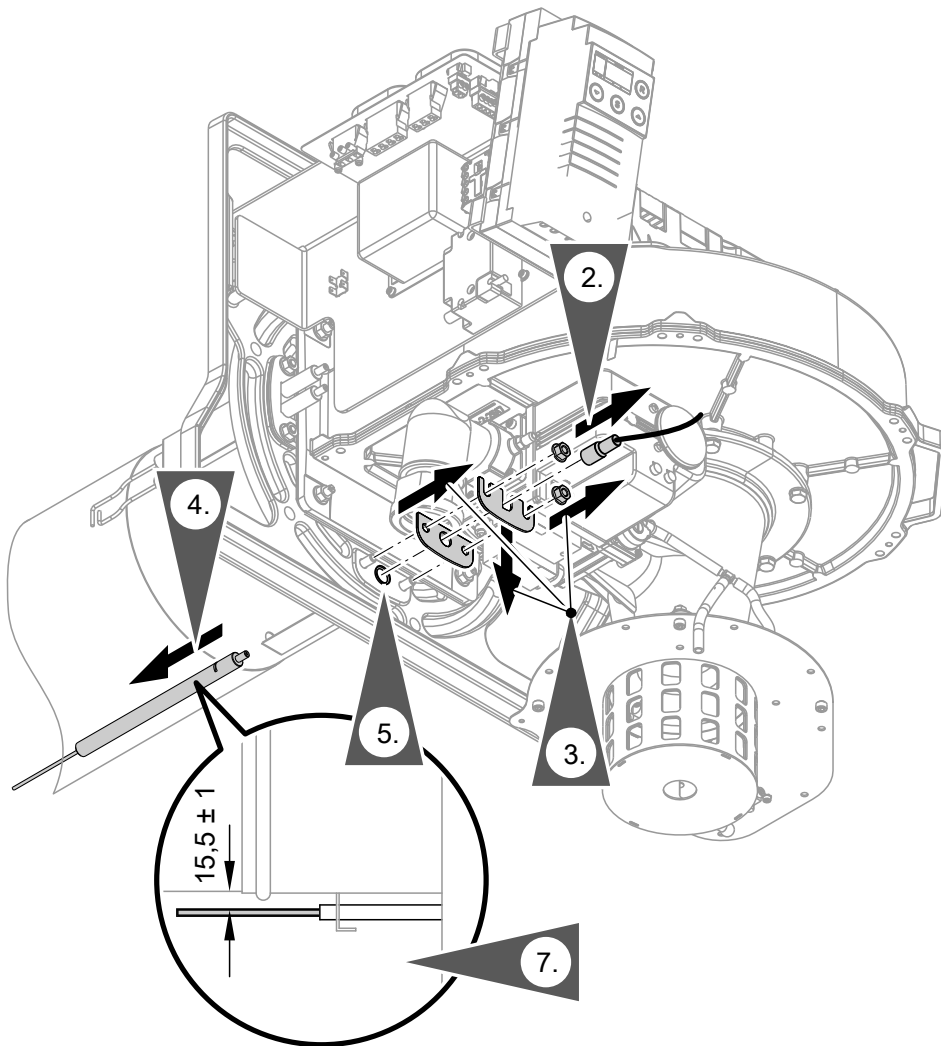

Fig. 11

1. Undo 6 x M 12 screws and open the boiler door.
2. Pull the connection plug from the ionisation electrode.
3. Undo 2 nuts on the centring plate and remove the centring plate and mounting plate.
Torque when installing: 4 Nm
4. Remove the electrode by pulling it forwards.
5. Replace O-ring.
6. Install a new ionisation electrode in reverse order.
7. Check the adjustment dimensions of the electrode and correct if required.
8. For further steps see chapter "Further assembly" on page 19.

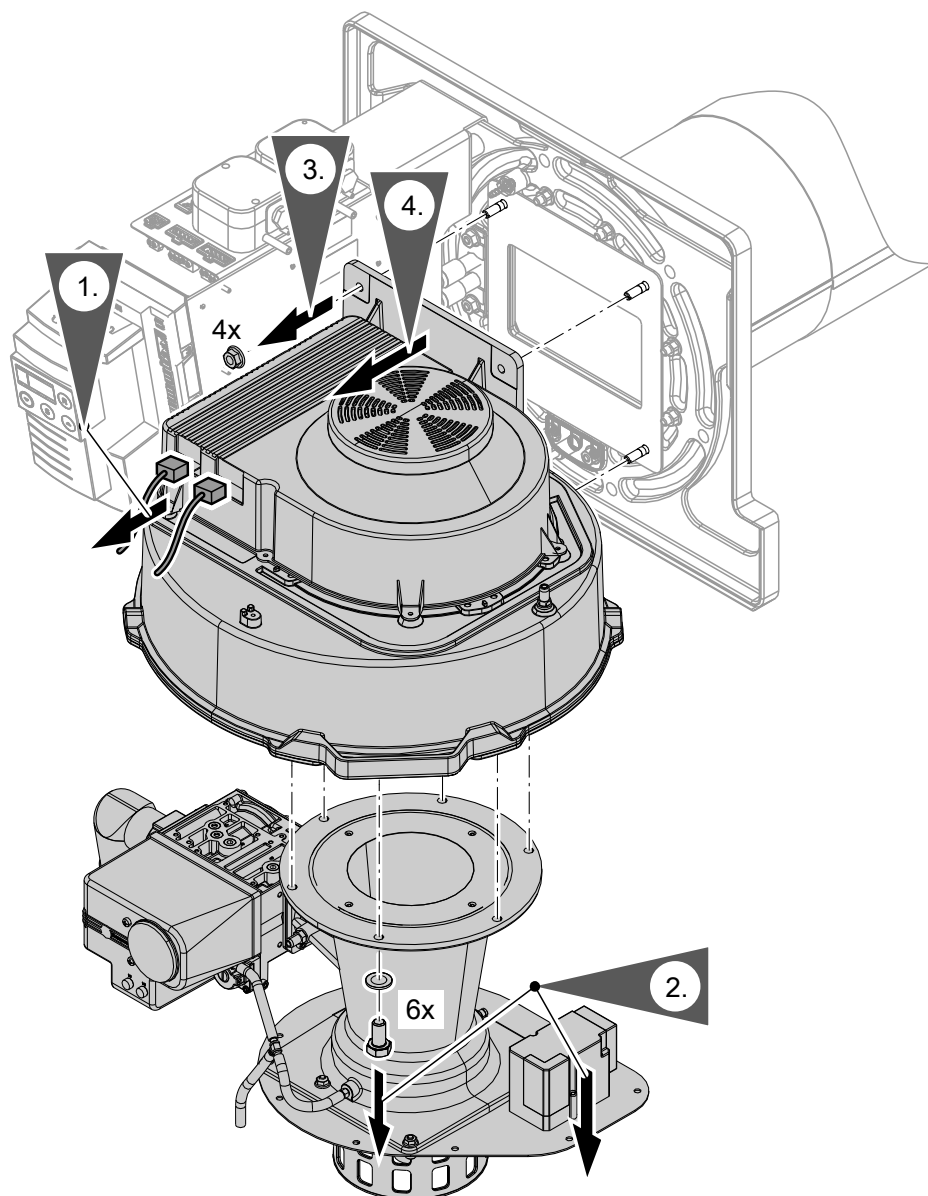

Fig. 12

1. Disconnect both plugs from the fan.
2. Remove 6 screws on the Venturi pipe. Remove the Venturi pipe with the fitted gas train.
Torque when installing: 6 Nm
3. Undo the hexagon nuts from the 4 studs.
4. Remove the fan, noting how the gasket is positioned.
5. Mount new fan with gasket and Venturi pipe with fitted gas train in reverse order.

Note
Fit gasket in the correct position.

6. For further steps see chapter "Further assembly" on page 19.

Rotary damper and servomotor

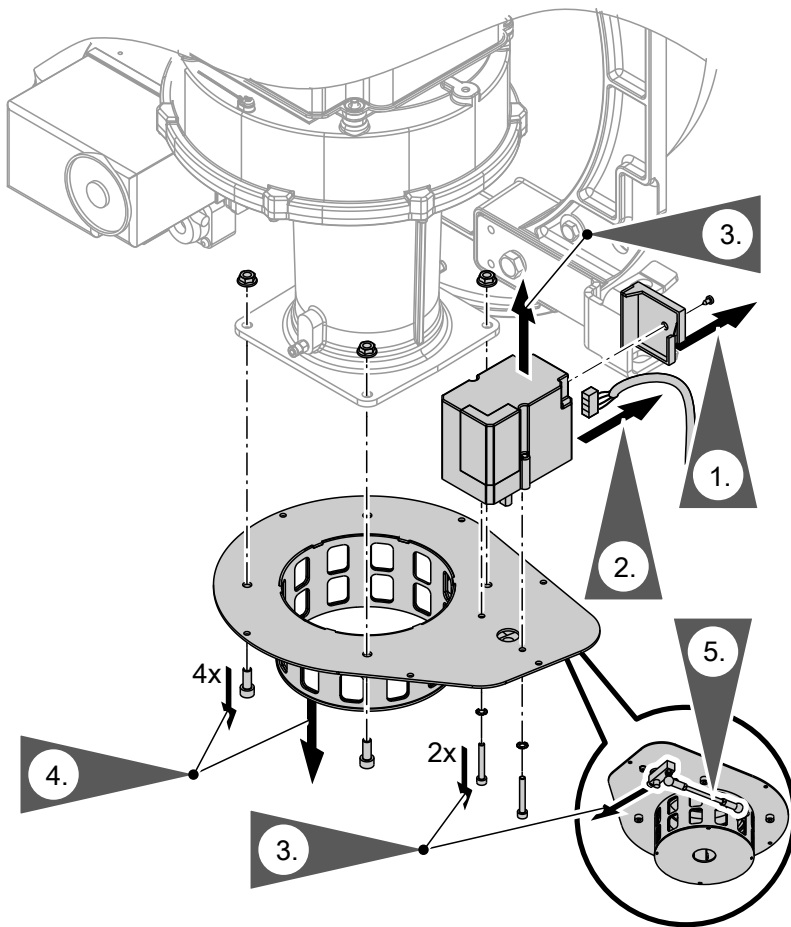

Fig. 13

1. Undo the screw in the servomotor cover and remove the cover.
 2. Pull the plug from the servomotor.
 3. Undo the screw on the servomotor axis and undo 2 servomotor fixing screws.
Torque when installing: 4 Nm
Remove the servomotor.
 4. Undo 4 screws from the retaining bracket of the rotary damper.
Torque when installing: 1.5 Nm
Remove rotary damper together with the retaining bracket.
 5. Release the articulated rod on the rotary damper with an open-ended spanner (SW 7).
 6. Install new rotary damper, air pressure switch and servomotor in reverse order.
- !** **Please note**
An incompletely opened rotary damper can cause malfunctions or indicate incorrect adjustment of the servomotor. Therefore, the rotary damper must be fully open when the burner is off and during operation. If necessary, adjust it via the articulated rod.
7. For further steps see chapter "Further assembly" on page 19.

Burner gauze assembly



Danger

Fibre dust can be produced if working with high temperature insulation materials that contain zirconium or aluminium silicate ceramic fibres. This fibre dust can be harmful to health.

Only trained personnel may adjust or replace the insulation. Wear suitable protective clothing, especially breathing equipment and safety goggles.

Removal

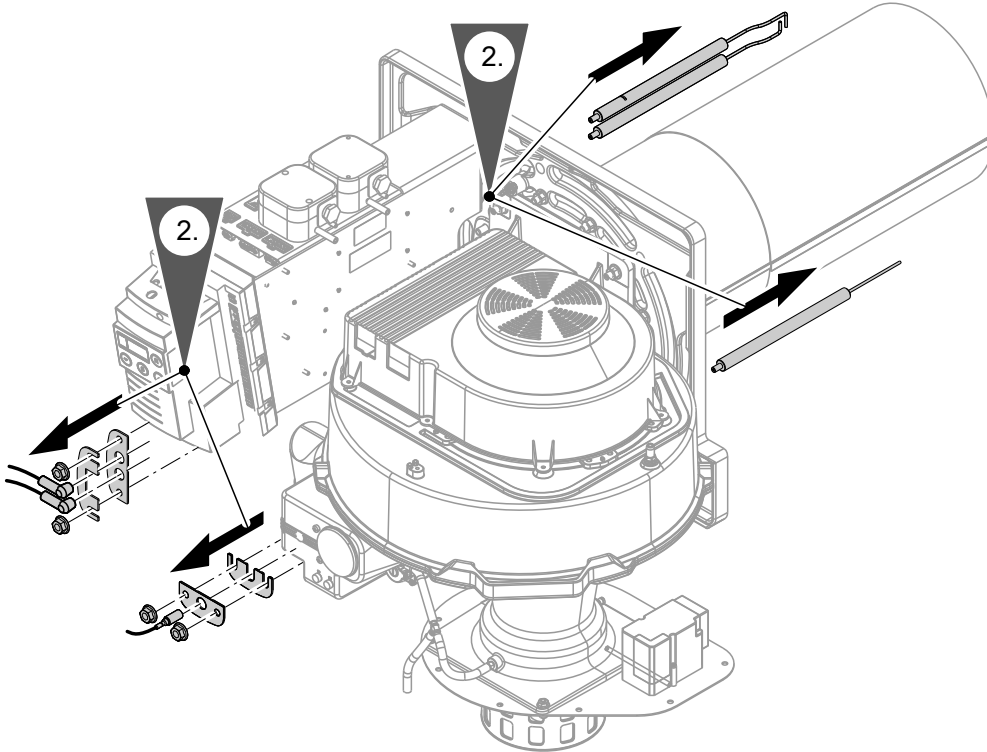

Fig. 14

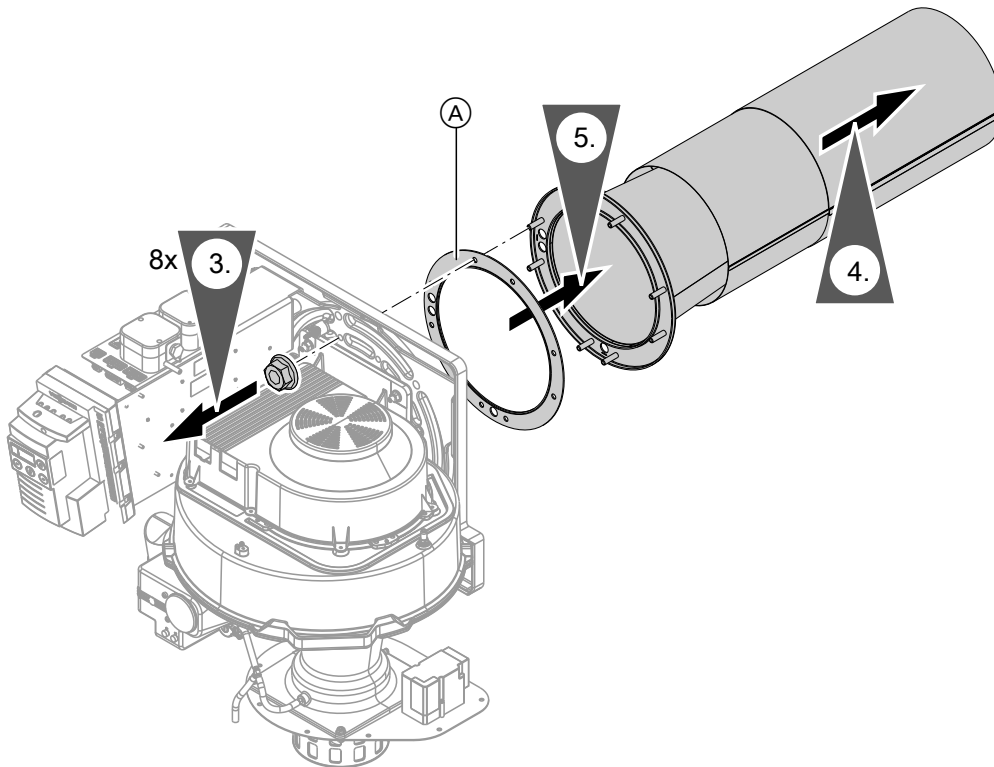

Fig. 15

1. Undo 6 x M 12 nuts and remove the burner with the frame from the boiler door.
- Note**
In view of the burner weight, the fan can be removed with the gas train in advance, if only one fitter is on site.
2. Remove the ignition electrode block and ionisation electrode block (see pages 12 and 13).
 3. Undo 8 x M 8 hexagon nuts on the burner frame to release the burner gauze assembly.
 4. Carefully remove the burner gauze assembly by pulling it forwards.
 5. Remove gasket (A) from the burner frame and clean the sealing faces.



Please note

Contamination of the burner gauze assembly can lead to malfunction. When replacing the burner gauze assembly ensure that no fibres from the thermal insulation block adhere to the burner gauze assembly. To prevent this from happening, fit a protective sleeve before installing the burner gauze assembly in the boiler door. Remove the protective sleeve once the flame tube is in place.



Please note

Incorrect replacement of the burner gauze assembly can result in contamination of the combustion chamber. Ensure that the combustion chamber is kept free of thermal insulation fibres.

Burner gauze assembly (cont.)

Installation

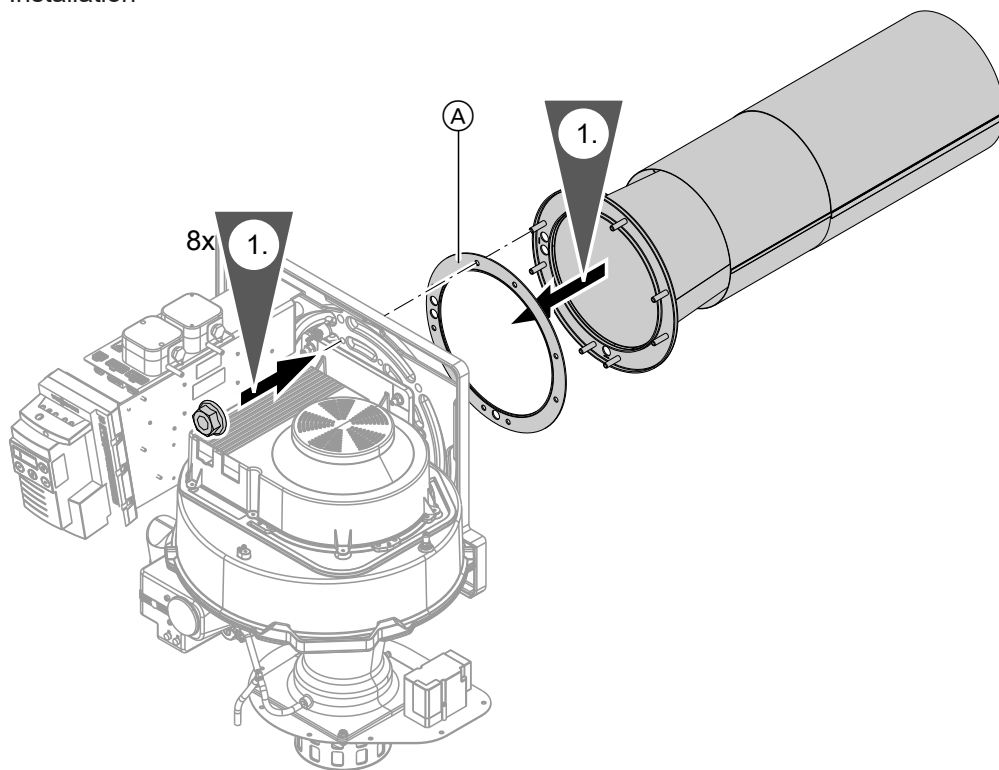

Fig. 16

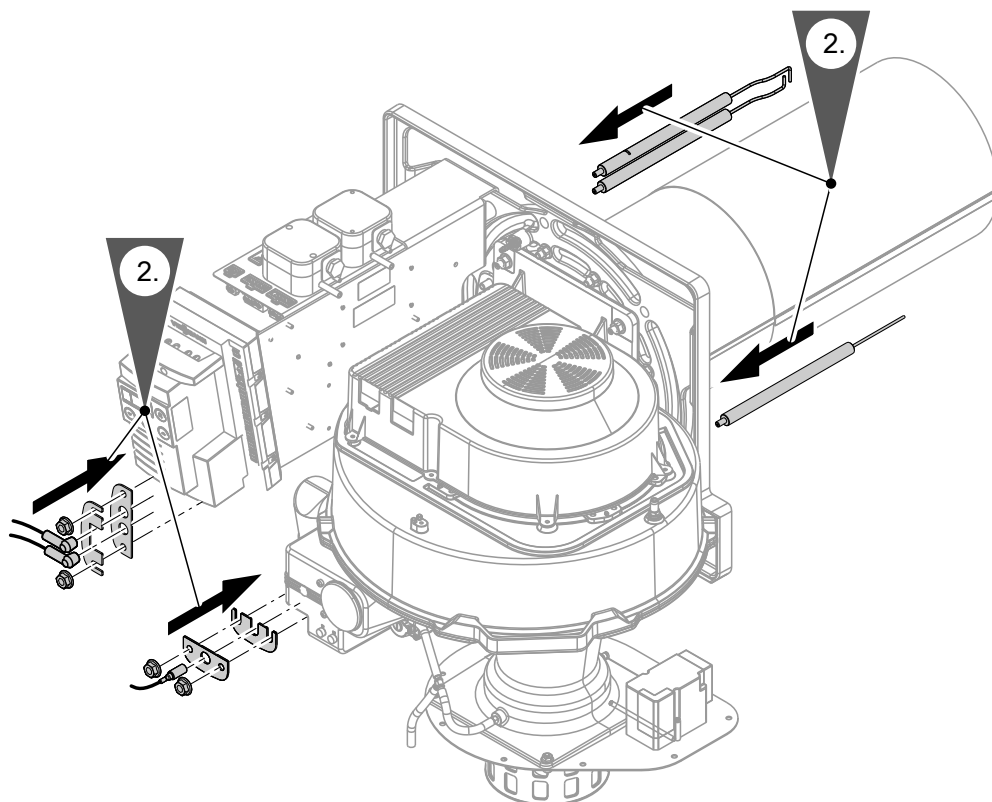

Fig. 17

1. Secure the burner gauze assembly with new gasket **A** to the burner frame with screws. To do so, first fit the M 8 nuts that will not be used to secure the electrodes.
Torque: 10 Nm
2. Install ignition electrodes and ionisation electrode with centring plate and mounting plate and new O-rings (see page 12 and 13). Secure with the remaining M 8 nuts.
Torque: 4 Nm

Burner gauze assembly (cont.)

3. Fit burner with frame and 6 x M 12 nuts to the boiler door.
Torque: 20 Nm
4. Seal the gap between the burner gauze assembly and the thermal insulation block in the boiler door using the flame tube gasket.

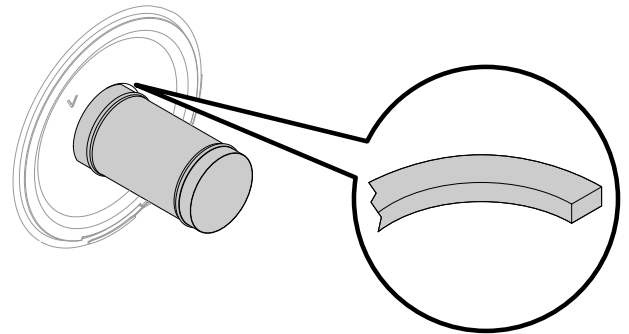

Fig. 18

Further assembly and commissioning

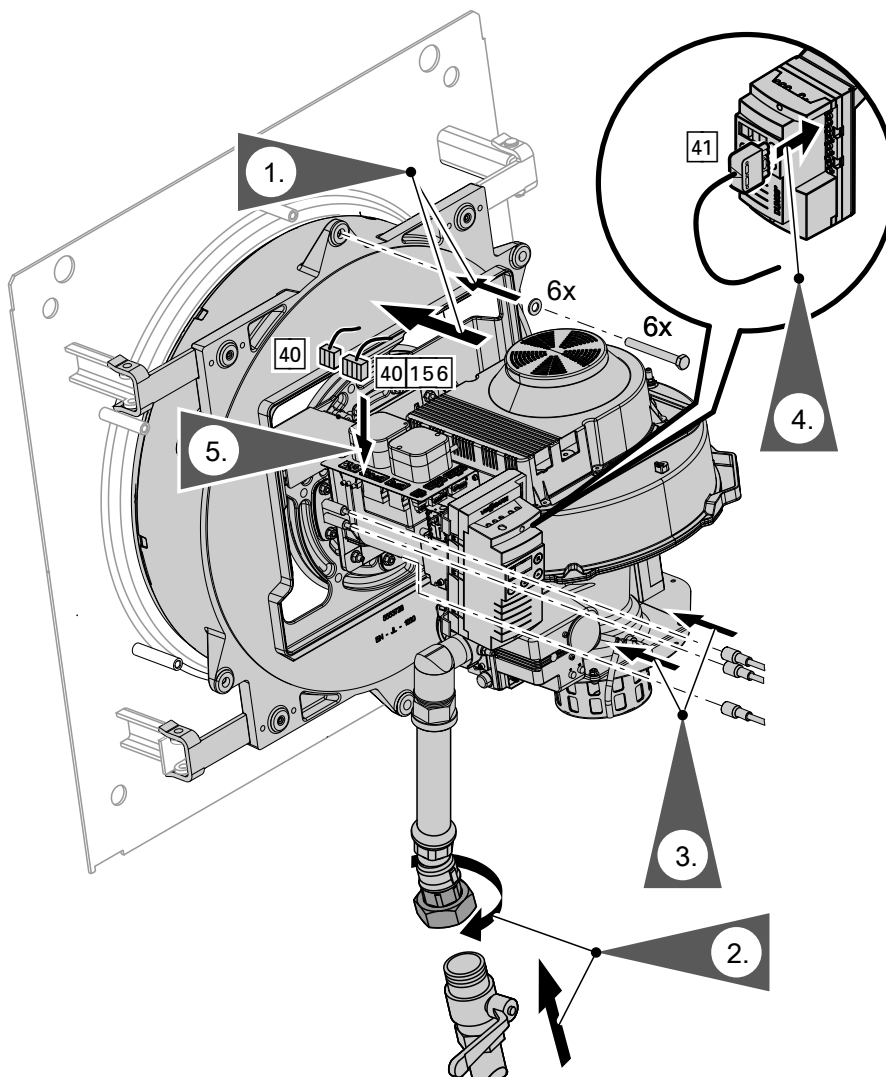

Fig. 19

1. If the boiler door is still open, close it. Insert 6 x M 12 screws and tighten diagonally.
Torque: 40 Nm

Further assembly and commissioning (cont.)

2. Fit the gas connection line.



Danger

Escaping gas leads to a risk of explosion.
Check the fitting for gas tightness.



Please note

The use of leak detection spray can result in faulty operation.
Leak detection spray must not come into contact with electrical contacts.

3. Push on the electrode plugs.

4. Insert all plugs at the plug-in panel and at the burner control unit; insert mains plug  last.

5. Start the burner and carry out a function test.



Burner service instructions

6. Fit front panels, the front top panel and the side panel.

Viessmann Climate Solutions SE
35108 Allendorf / Germany
Telephone: +49 6452 70-0
Fax: +49 6452 70-2780
www.viessmann.com



Viessmann Limited
Hortonwood 30, Telford
Shropshire, TF1 7YP, GB
Telephone: +44 1952 675000
Fax: +44 1952 675040
E-mail: info-uk@viessmann.com

5671715 Subject to technical modifications.