

# Vitocell 200 Cylinder

## Design, Installation, User & Servicing Instructions

An unvented hot water storage appliance complying with the requirements of Building Regulations Approved Document G3 and manufactured in accordance with BS EN 12897, the specification for unvented water storage vessels.

In the interest of continuously improving the Vitocell 200 Cylinder range, Viessmann reserve the right to modify the product without notice, and in these circumstances this booklet, which is accurate at the time of printing, should be disregarded.



# CONTENTS

These instructions should be read in conjunction with the installation/servicing instructions issued by the manufacturer of the heat source being used.

Any installation must be in accordance with the relevant requirements of the Gas Safety Regulations, Building Regulations, I.E.E. Wiring Regulations and the Water Fitting Regulations (England and Wales) or Water Byelaws (Scotland). It should be read in accordance with the relevant recommendations of the following:

BS 6798; BS EN 12828, BS EN 12831, BS EN 14336; BS 5546;  
BS 5440:1; BS 5440:2; CP 331:3  
BS EN 806-1 to 5, BS EN 8558:2011; BS EN 1458-1:2011 and BS 7593:2006

Viessmann Vitocell 200 Cylinder is covered by Section G3 of the Building Regulations (England and Wales) Technical Standard P3 (Scotland) and Building Regulation P5 (Northern Ireland). Compliance can be achieved via a Competent Person Self Certification Scheme or notification of installation to the Local Authority Building Control Department.

It must be installed by a competent person as defined by the relevant regulations. Manufacturers notes must NOT be taken as over-riding statutory obligations.

This appliance is not intended for use by persons (including children) with reduced physical, sensory or mental capabilities, or lack of experience and knowledge unless they have been given supervision or instruction concerning use of the appliance by a person responsible for their safety. Children should be supervised at all times to ensure they do not play with the appliance.

This information is provided to assist generally in the selection of equipment. Responsibility for selection and specification of our equipment must however remain that of our customer and any experts or consultants concerned with the installation(s).

**Please note:** that we do not therefore accept any responsibility for matters of design selection or specification, for the effectiveness of an installation or system containing one of our products unless specifically requested to do so in writing.

All goods are sold subject to our conditions of sale which are set out at the rear of this specification. In the interest of continuously improving the Viessmann Vitocell 200 Cylinder range, Viessmann Limited reserve the right to modify the product without notice, and in these circumstances this booklet, which is accurate at the time of printing, should be disregarded. An updated set of instructions will be produced and supplied with new appliances and will be made available for other appliances on request.

**This product is approved by Advantica where it is sold as a package with a Viessmann boiler.**

**Viessmann Vitocell 200 cylinders are produced under an ISO 9001:2008 Quality Management System approved by BSI.**



Benchmark places responsibilities on both manufacturers and installers. The purpose is to ensure that customers are provided with the correct equipment for their needs, that it is installed, commissioned and serviced in accordance with the manufacturers instructions by competent persons and that it meets the requirements of the appropriate Building Regulations. The Benchmark Checklist can be used to demonstrate compliance with Building Regulations and should be provided to the customer for future reference.

Installers are required to carry out installation, commissioning and servicing work in accordance with the Benchmark Code of Practice which is available from the Heating and Hot Water Industry Council who manage and promote the Scheme. Visit [www.centralheating.co.uk](http://www.centralheating.co.uk) for more information.

## ISSUE 22: JANUARY 2016

Section	Page
<b>DESIGN</b>	
Description	3
Technical Data	6
System Details	8
<b>INSTALLATION</b>	
Installation	10
Commissioning	20
<b>USER INSTRUCTIONS</b>	21
<b>SERVICING</b>	
Servicing and Maintenance	22
Fault Finding	23
Spare Parts List	26
<b>ADDENDIX</b>	
Addendix A	27
Addendix B	28
Notes	29
<b>BENCHMARK</b>	
Commissioning Checklist	30
Service Record	31

## Supplied By: Viessmann Ltd

Maximum inlet pressure to Pressure reducing valve	12 bar
Operating pressure (PRV setting)	3 bar
Expansion vessel charge pressure	3 bar
Expansion relief valve setting	4.5 bar
Opening pressure of P & T Relief Valve	6 bar
Opening temperature of P & T Relief Valve	92-95°C
Energy cut-out thermostat setting	85°C
Max. working pressure - Primary heat exchanger (Indirect models)	6 bar
Max. working pressure - Solar heat exchanger (Solar models)	10 bar
Immersion heater rating	3kW, 240V AC

All cylinders are manufactured in accordance with the requirements of BS EN 12897. The tundish must be positioned so that it is visible to the occupant and is away from electrical devices.

Components supplied with Viessmann Vitocell 200 cylinders

- Cold water inlet PRV combination valve/expansion relief
- Pressure and temperature relief valve
- Tundish
- 3kW Immersion heater including control and cut out thermostats
- Expansion vessel/mounting bracket/flexible hose
- Cylinder temperature sensor and retaining clip (ZK00539)
- Technical/user product literature

Optional Extras

- Control thermostat
- Energy cut-out thermostat
- Energy cut-out motorised valve

**(Note:** Please refer to tables 1 and 2 on pages 6-9 to confirm the quantity of immersion heaters supplied with the unit)

In any situation where the volume of heated pipework (eg. secondary circulation pipes or manifold pipework for multiple units) exceeds 10 litres, then an additional expansion vessel must be fitted to accommodate the extra expansion volume.

## Handling Before Installation

Viessmann Vitocell 200 Cylinder must be handled with care and stored the correct way up in a dry place. Any manual handling/lifting operations will need to comply with the requirements of the Manual Handling Operations Regulations issued by the H.S.E. The appliance can be moved using a sack truck on the rear face although care should be taken and the route should be even. In apartment buildings containing a number of storeys we would recommend that the appliances are moved vertically in a mechanical lift. If it is proposed to use a crane, expert advice should be obtained regarding the need for slings, lifting beams etc.

A specific manual handling assessment is shown in Appendix B at the rear of this manual.

## Maintenance

Modifications should not be made to this product. Replacement parts, including immersion heaters, should be purchased from Viessmann Limited, or agents approved by them. Unvented hot water storage vessels need regular routine checks, and these are detailed below. It is for this reason that this manual must always be left with the Viessmann Vitocell 200 Cylinder.

It is essential that these checks be carried out at the time of boiler maintenance by a qualified installer:

1. Manually open the relief valves in turn, and check that water is discharged from the valves and runs freely through the tundish and out at the discharge point. Ensure that the valves re-seat satisfactorily. (Note - the water may be very hot).
2. It is important to check that the discharge pipework is carrying the water away adequately. Check for blockages etc. if it is not.
3. Turn the mains water off and remove and clean the strainer element in the Pressure Reducing Valve.
4. Check the charge pressure in the expansion vessel and repressurise if required
5. Re-fill the system and ensure that all relief valves have re-seated.
6. The Benchmark Service Record should be updated at each service.
7. Check the water pressure downstream of the combination valve is 3 bar in static condition.
8. Check and if necessary, descale the heat exchanger in hard water areas ie. above 200ppm (mg/l).

## Note:

The cylinder is factory fitted with a temperature & pressure relief valve that must not be used for any other purpose or removed.

The cylinder is factory fitted with immersion heaters with thermal cut outs. Immersions without thermal cut outs must not be fitted.

**Figure 1**

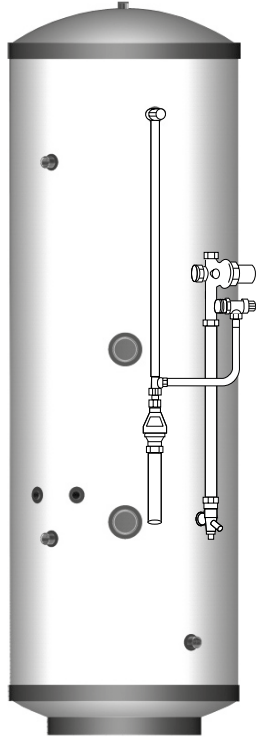

## **Viessmann Vitocell 200-V Cylinder**

**Pipework is not supplied by manufacturer,  
but to be supplied and fitted by installer.**

### **Introduction**

Viessmann Vitocell 200 Cylinder is a range of unvented hot water storage cylinders, manufactured in the latest high quality duplex stainless steel. They are designed to provide mains pressure hot water and are supplied as a package which complies with Section G3 of the Building Regulations. The appliance is extremely well insulated using high density HCFC free foam insulation with an ozone depleting potential (ODP) of zero and a global warming potential (GWP) of 1. It is fitted with all necessary safety devices and supplied with all the necessary control devices to make installation on site as easy as possible.

**Viessmann Vitocell 200 Cylinder is available in two basic variants:**

1. **Viessmann Vitocell 200-V Cylinder** - For use with gas or oil boilers (Figure 1). Vitocell 200 Cylinders must not be used with solid fuel boilers or steam as the energy source.
2. **Viessmann Vitocell 200-B Solar Cylinder** - For providing hot water by solar gains and gas or oil boilers (Figure 2). Unvented cylinders must not be used with solid fuel boilers or steam as the energy source.

### **Viessmann Vitocell 200-V Cylinder**

Viessmann Vitocell 200-V Cylinder is an unvented hot water storage cylinder and is provided with a high efficiency internal primary coil which is designed for use with a gas or oil boiler and is suitable for both open vented and sealed **pumped** primary systems.

When used with a sealed heating system the boiler must incorporate its own energy cut-out overheat thermostat.

Viessmann Vitocell 200-V Cylinder models are listed in Table 1 on Page 6 & 7.

**Figure 2**

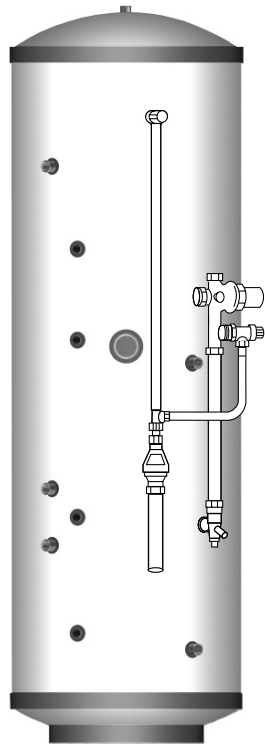

## Viessmann Vitocell 200-B Solar Cylinder

**Pipework is not supplied by manufacturer,  
but to be supplied and fitted by installer.**

### **Viessmann Vitocell 200-B Solar Cylinder**

Viessmann Vitocell 200-B Solar Cylinder is an unvented hot water storage cylinder and is provided with a high efficiency internal primary coil which is designed for use with a gas or oil boiler and is suitable for both open vented and sealed pumped primary systems.

When used with a sealed heating system the boiler must incorporate its own energy cut-out overheat thermostat.

A high efficiency second solar coil is positioned below the primary coil to ensure maximum benefit of solar gain energy.

Viessmann Vitocell 200-B Solar Cylinder models are listed in Table 1 on Page 6 & 7.

#### **Note:**

**The cold supply elbow c/w drain tapping must be fitted as shown in figs 1, 2, 3 and 4. A flexible hose can then be connected to the drain tapping and, providing the hose runs below the lowest level of the cylinder, then all the water contents can be drained out by syphonic action. (The cold feed pipe dips internally to the base of the cylinder.)**

# DESIGN

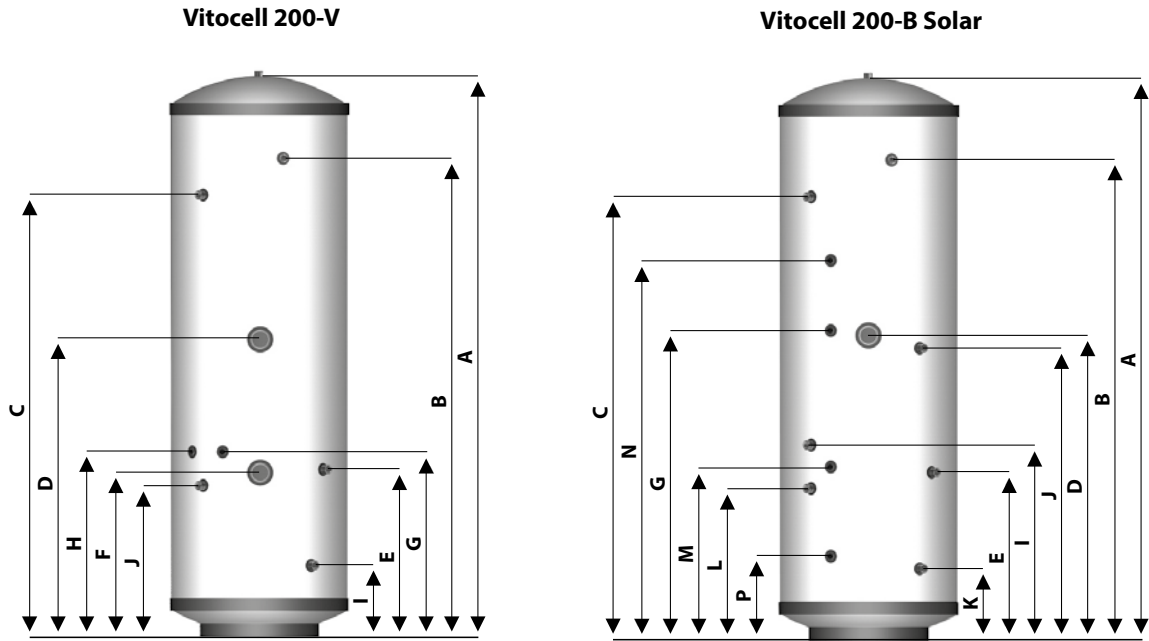

**Table 1**

Model	Product Stock Code	Energy Efficiency Class	Heat Loss		Capacity (Total Volume)	Weight - Empty	Weight - Full	Pressure Regulator 3 bar inlet group c/w balance cold supply, expansion vessel connection and expansion valve set at 4.5 bar	Expansion Vessel size. Pre-charged to 3 bar	Overall Height	Overall Diameter	Pressure & Temperature Relief Valve 6bar 95°C	22mm Secondary Return Tapping	On Peak Immersion Heater - High Level
			Watts	Litres										
Vitocell 200-V														
90	7572707	B	35	90	19	109	3	12	745	550	490	n/a	352	
120	7572708	B	44	120	22	142	3	12	930	550	678	n/a	352	
150	7572709	B	51	150	26	176	3	18	1120	550	865	n/a	392	
180	7572710	B	54	180	28	208	3	18	1305	550	1053	n/a	432	
210	7572711	C	65	210	33	243	3	24	1495	550	1241	1127	432	
250	7572712	C	75	250	38	288	3	24	1745	550	1491	1377	927	
300	7572713	C	85	300	44	344	3	35	1992	550	1720	1577	1077	
Vitocell 200-B Solar														
210	7572714	C	65	210	35	245	3	24	1495	550	1240	1127	723	
250	7572715	C	75	250	40	290	3	24	1745	550	1491	1377	785	
300	7572716	C	85	300	46	346	3	35	1992	550	1720	1577	910	

TECHNICAL DATA

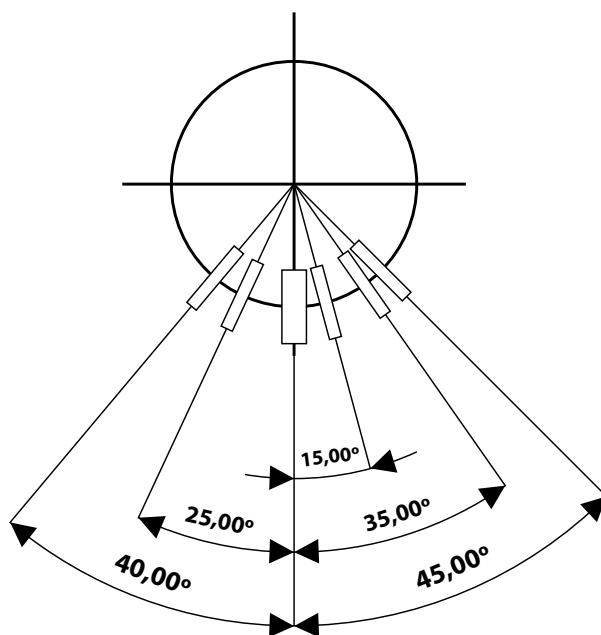

## NOTES

1. Not all models - see table 1.
2. Recovery times based on Primary Coil/I.H. duty (ie. assumes the boiler output is adequate).
3. All connections are supplied with compression fittings for direct connection to copper pipework.
4. The diagrams shown are generic. For exact product specification refer to the table eg. the number of immersion heaters varies depending on model.
5. Heat up and recovery times based on 0.25 l/s primary flow rate and at 82°C flow temperature.

Cold Feed 22mm Compression Connection	Off Peak Immersion Heater - Low Level	Volume of On Peak Water Heated	Dual Control & Overheat Stat	Extra Stat Pocket For Boiler Use if Required	22mm Primary Return Compression Connection	22mm Primary Flow Compression Connection	22mm Solar Return Compression Connection	22mm Solar Flow Compression Connection	Dual Control & Overheat Stat	Solar Pocket	Solar Pocket	kW Rating of Primary Coil	Surface Area of Primary Heater Coil	Pressure Loss Across Primary Heater Coil	Surface Area of Solar Heater Coil	Pressure Loss Across Solar Heater Coil	Heat Up Time from 15°C to 60°C (applies to Primary Heat Source only)	Dedicated Solar Volume
E=mm	F=mm	Litres	G=mm	H=mm	I=mm	J=mm	K=mm	L=mm	M=mm	N=mm	P=mm	kW	m <sup>2</sup>	bar	m <sup>2</sup>	bar	min	Litres
367	n/a	40	367	367	223	312	n/a	n/a	n/a	n/a	n/a	16.5	0.59	0.165	n/a	n/a	17	n/a
367	n/a	67	367	367	223	312	n/a	n/a	n/a	n/a	n/a	18	0.59	0.165	n/a	n/a	21	n/a
442	n/a	92	407	407	223	392	n/a	n/a	n/a	n/a	n/a	18.5	0.68	0.191	n/a	n/a	25	n/a
442	n/a	116	447	447	223	392	n/a	n/a	n/a	n/a	n/a	19	0.78	0.216	n/a	n/a	30	n/a
442	n/a	145	482	482	223	392	n/a	n/a	n/a	n/a	n/a	25.6	1.37	0.297	n/a	n/a	32	n/a
522	512	109	577	577	223	472	n/a	n/a	n/a	n/a	n/a	27.1	1.37	0.297	n/a	n/a	36	n/a
522	512	130	677	677	223	522	n/a	n/a	n/a	n/a	n/a	24.9	1.37	0.297	n/a	n/a	38	n/a
437	n/a	95	888	n/a	758	1018	223	352	419	1000	233	18.5	0.68	0.191	0.680	0.191	35	101
522	n/a	115	970	n/a	820	1120	223	472	539	1180	294	19	0.78	0.216	0.970	0.241	38	107
522	n/a	140	1095	n/a	945	1245	223	472	539	1367	300	20.5	0.78	0.216	0.970	0.241	41	125

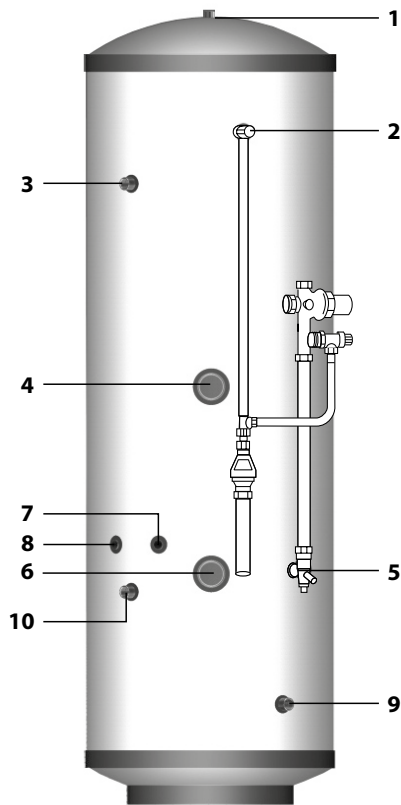

Typical arrangement of component kit shown fitted to the appliance for clarity  
**Pipework to be supplied and fitted by installer.**

## Viessmann Vitocell 200-V Cylinder

### Basic Appliance

1. Hot water draw off (22mm) compression
2. Temperature & pressure relief valve 92-95°/6 bar
3. Hot water secondary return 22mm (not fitted to smaller sizes, see table 1)
4. Immersion heater 1 3/4" BSP 3kW
5. 22mm cold supply compression
6. Immersion heater 1 3/4" BSP 3kW
7. Dual control/overheat stat pocket (22mm)
8. Boiler control sensor pocket (spare)
9. Primary return (22mm)
10. Primary flow (22mm)

### Part G3 loose components supplied in a separate box

- A. Combination inlet group incorporating pressure reducing valve, strainer, check valve, balanced cold take off point, expansion relief valve and expansion vessel connection points.
- B. Potable expansion vessels c/w flexible hose and wall bracket
- C. Tundish
- D. Wiring junction box for primary system
- E. Cylinder temperature sensor and fixing clip (part number ZK00539)

### Optional components available

- A. Dual control thermostat and combined overheat thermostat
- B. Two port (22mm) zone valve for primary circuit



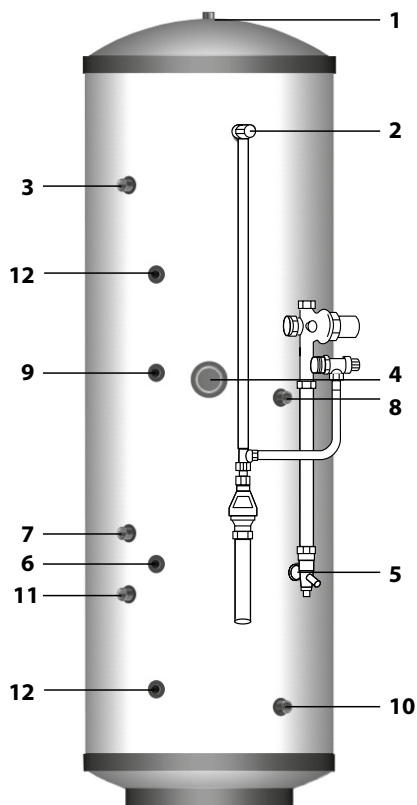

Typical arrangement of component kit shown fitted to the appliance for clarity  
**Pipework to be supplied and fitted by installer.**

## Viessmann Vitocell 200-B Solar Cylinder

### Basic Appliance

1. Hot water draw off (22mm) compression
2. Temperature & pressure relief valve 92-95°/6 bar
3. Hot water secondary return 22mm (not fitted to smaller sizes, see table 1)
4. Immersion heater 1 $\frac{3}{4}$ " BSP 3kW
5. 22mm cold supply
6. Dual control/Overheat stat pocket (solar)
7. Primary return (22mm)
8. Primary flow (22mm)
9. Dual control/Overheat stat pocket (boiler)
10. Solar coil return to panel collector (22mm) compression
11. Solar coil flow from panel (22mm) compression
12. Solar thermostat pocket

### Part G3 loose components supplied in a separate box

- A. Combination inlet group incorporating pressure reducing valve, strainer, check valve, balanced cold take off point, expansion relief valve and expansion vessel connection points.
- B. Potable expansion vessels c/w flexible hose and wall bracket
- C. Tundish
- D. Wiring junction box for primary system
- E. Cylinder temperature sensor and fixing clip (part number ZK00539)

### Optional components available

- A. Dual control thermostat and combined overheat thermostat (x2)
- B. Two port (22mm) zone valve for primary circuit

# INSTALLATION

## General Design Considerations

The cupboard footprint needs to be at least 650mm square for units.

The base chosen for the cylinder should be level and capable of supporting the weight of the unit when full of water as shown in General Data. The discharge pipework for the safety valves must have a minimum fall of 1 : 40 from the unit to a safe discharge point. All exposed pipework and fittings on the cylinder should be insulated, and the unit should NOT be fixed in a location where the contents could freeze.

In new systems, pipes should be insulated to comply with building regs, the maximum permissible heat loss is indicated in the table opposite, and labelled accordingly as follows:

- i. Primary circulation pipes for domestic hot water circuits should be insulated throughout their length, subject only to practical constraints imposed by the need to penetrate joists and other structural elements.
- ii. All pipes connected to hot water storage vessels, including the vent pipe, should be insulated for at least 1 metre from their points of connection to the cylinder (or they should be insulated up to the point where they become concealed).

In replacement systems, whenever a boiler or hot water storage vessel is replaced in an existing system, any pipes that are exposed as part of the work or are otherwise accessible should be insulated as recommended for new systems, or to some lesser standard where practical constraints dictate.

**The pipe connecting the boiler flow to the appliance must not be less than 22mm copper or equivalent.**

Further guidance on converting heat loss limits to insulation thickness for specific thermal conductivities is available in TIMSA "HVAC guidance for achieving compliance with Part L of the Building Regulations".

Insulation of pipework	
Pipe outside diameter	Maximum heat loss
15mm	7.89W/m
22mm	9.12W/m
28mm	10.07W/m
35mm	11.08W/m

## Mains Water Supply

Existing properties with a 15mm supply will be satisfactory provided the local mains pressure is good, but should be confined to single bathroom properties. For new properties where simultaneous demand is required to more than one bathroom or a bathroom and one or more en-suites, the communication and service pipe into the dwelling should be a minimum of 22mm (usually in the form of a 25mm MDPE supply). The optimum performance is achieved if the inlet pressure is 3 bar dynamic. However, the Viessmann Vitocell 200 cylinder will function with lower inlet pressures, but this will reduce the performance. For optimum performance, 30L per minute incoming mains flow should be present, however the Viessmann Vitocell will work at lower flow rates, although performance will be affected. Normally Viessmann Vitocell 200 Cylinder provides well in excess of 40 litres/min in most conditions. Flow rates for ALL mains pressure systems are subject to district pressures and system dynamic loss. Particularly on larger properties with more than one bathroom, the pipe sizes should be calculated in accordance with BS EN 806-3:2006 and BS 8558:2011.

## Model Selection

The suggested model sizes are based on typical hot water usage. For high specification dwellings an increase of one model size should be considered.

Model Selection Guide		
Max hot water demand	Max number of bed spaces (Bedrooms)	Litres
1 shower room	Bedsit (0)	90
1 bathroom	2 (2)	120
1 bathroom	4 (3)	120
1 bathroom + separate shower room	6 (4)	150
1 bathroom + 2 separate shower rooms or 2 bathrooms	7 (5)	180
2 bathrooms + separate shower room	7 (5)	210
2 bathrooms + 2 separate shower rooms	7 (5)	250
3 bathrooms + 2 separate showers rooms	9 (6)	300

Solar Model Selection Guide		
Max hot water demand	Bedrooms	Litres
1 bathroom + 1 shower room	1-3	210
1 bathroom + 2 shower rooms	2-4	250
2 bathrooms + 1 shower room	3-4	300



# INSTALLATION

## Typical Discharge Pipe Arrangement

### Typical Discharge Pipe Arrangement

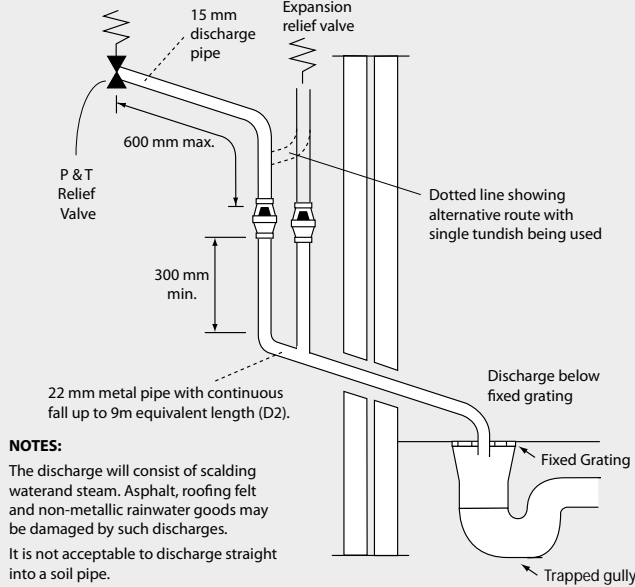

## Pressure & Temperature/expansion Relief Valve Pipework

The relief valve should be installed to discharge in accordance with G3 of the Approved Document of the Building Regulations and should be piped to where it is visible, but will not cause danger to persons or damage to materials.

The following information is taken from Approved Document G3 of the Building Regulations and is provided to assist with the design and installation of the discharge pipework. However, the information is not exhaustive and reference should always be made to Approved Document G3 of the Building Regulations. The final decision regarding any arrangements rests with Building Control and it is recommended that their advice is sought if you have any concerns regarding this aspect of the installation.

The two safety valves will only discharge water under fault conditions. When operating normally water will not be discharged.

The tundish should be vertical, located in the same space as the unvented hot water storage system and be fitted as close as possible and within 600mm of the safety device e.g. the temperature relief valve.

The discharge pipe (D2) from the tundish should terminate in a safe place where there is no risk to persons in the vicinity of the discharge, be of metal and:

- a) Be at least one pipe size larger than the nominal outlet size of the safety device unless its total equivalent hydraulic resistance exceeds that of a straight pipe 9m long i.e. discharge pipes between 9m and 18m equivalent resistance length should be at least two sizes larger than the nominal outlet size of the safety device, between 18 and 27m at least 3 sizes larger, and so on. Bends must be taken into account in calculating the flow resistance. Refer to the table and the worked example.

An alternative approach for sizing discharge pipes would be to follow BS EN 806-2:2005 Specification for design installation, testing and maintenance of services supplying water for domestic use within buildings and their curtilages.

- b) Have a vertical section of pipe at least 300mm long, below the tundish before any elbows or bends in the pipe work.

- c) Be installed with a continuous fall.

## WORKED EXAMPLE

The example below is for G1/2 temperature relief valve with a discharge pipe (D2) having 4 elbows and length of 7m from the tundish to the point of discharge.

From the table below:

Maximum resistance allowed for a straight length of 22mm copper discharge pipe (D2) from a G1/2 temperature relief valve is: 9m subtract the resistance for 4 x 22mm elbows at 0.8m each = 3.2m.

Therefore the maximum permitted length equates to: 5.8m.

5.8m is less than the actual length of 7m therefore calculate the next largest size.

Maximum resistance allowed for a straight length of 28mm pipe (D2) from a G1/2 temperature relief valve equates to: 14m.

As the actual length is 7m, a 28mm (D2) copper pipe will be satisfactory.

### Sizing of copper discharge pipe 'D2' for a temperature relief valve with a G1/2 outlet size (as supplied)

Size of discharge pipework	Maximum length of straight pipe (no bends or elbows)	Deduct the figure below from the maximum length for each bend or elbow in the discharge pipe
22mm	Up to 9m	0.8m
28mm	Up to 18m	1m
35mm	Up to 27m	1.4m

d) It is preferable for the discharge to be visible at both the tundish and the final point of discharge but where this is not possible or practically difficult there should be clear visibility at one or other of these locations. Examples of acceptable discharge arrangements are:

1. Ideally below the fixed grating and above the water seal in a trapped gully.
2. Downward discharges at a low level; i.e. up to 100mm above external surfaces such as car parks, hard standings, grassed areas etc are acceptable providing that where children play or otherwise come into contact with discharges, a wire cage or similar guard is positioned to prevent contact whilst maintaining visibility.
3. Discharges at a high level; e.g. into metal hopper and metal down pipe with the end of the discharge pipe clearly visible (tundish visible or not) or onto a roof capable of withstanding high temperature discharges of water and 3m from any plastic guttering systems that would collect such discharges.
4. Where a single pipe serves a number of discharges, such as in blocks of flats, the number served should be limited to not more than 6 systems so that any installation can be traced reasonably easily. The single common discharge pipe should be at least one pipe size larger than the largest individual discharge pipe to be connected. If unvented hot water storage systems are installed where discharges from safety devices may not be apparent i.e. in dwellings occupied by blind, infirm or disabled people, consideration should be given to the installation of an electronically operated device to warn when discharge takes place.

## Safety

The safety devices supplied or fitted on a Viessmann Vitocell 200 Cylinder are selected for their suitability for the temperatures and pressures involved. They must not be changed, removed or by-passed and it is essential that only genuine replacement parts supplied or approved by Viessmann Limited are used. This includes the immersion heaters, which must incorporate an energy cut-out. All parts are available to approved installers from Viessmann Limited. Where the boiler and cylinder are supplied as a package we have Advantica approval.

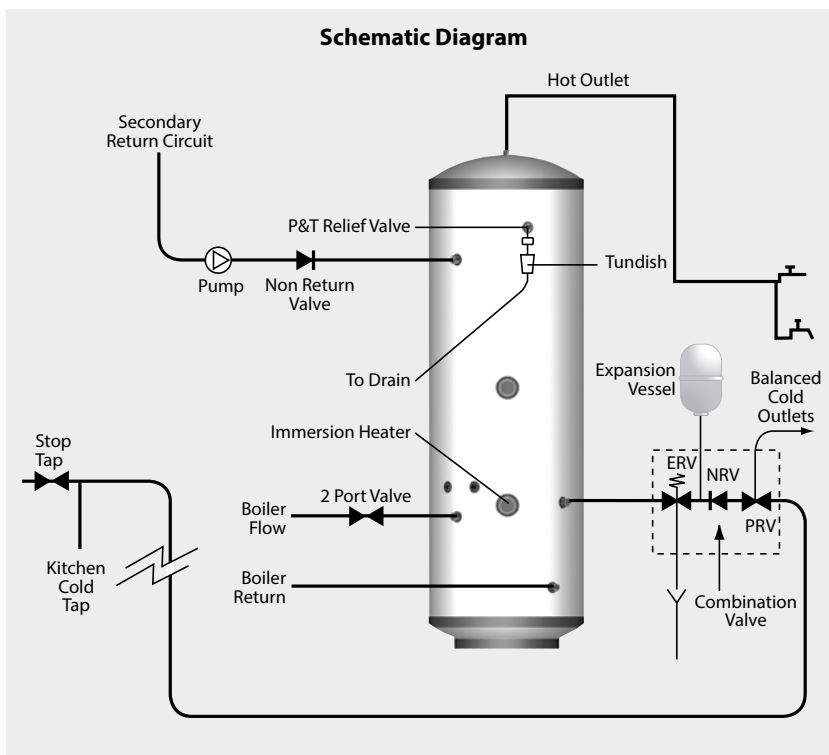

## Combination Inlet Group

Combines elements 1, 2 and 3 below.

1. *Pressure Reducing Valve* - This must be fixed near the cylinder. The cold water supply to any mixer taps/showers must be taken from the cold water tapping of this valve to ensure balanced hot and cold pressures. This valve is factory set to ensure the correct operating pressure for the Viessmann Vitocell 200 Cylinder.
2. *Non Return Valve* - This is integral with the pressure reducing valve to prevent backflow of hot water towards cold water draw off points.
3. *Cold Water Expansion Relief Valve* - This safety device is preset at the factory and will relieve excess cold water pressure resulting from a fault condition.

# INSTALLATION

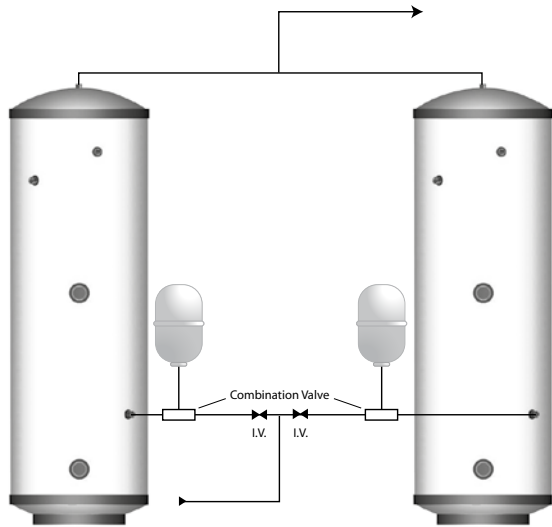

If two Viessmann Vitocell 200 Cylinders are coupled together the secondary inlet and outlet pipes must be balanced. The units must be fitted on the same level.

**Note: No valves must be fitted between the expansion vessel and the storage cylinder(s).**

## Temperature/Pressure Relief Valve

This safety device is also pre-set at the factory and relieves before the temperature reaches 100°C. It is also a Pressure Relief Valve, and is pre-set to 6 bar.

## Immersion Heaters

These are 3kW 240V AC heaters and incorporate a thermostat and a manually reset energy cut-out which operates at 85°C. They have incolloy elements to prolong their life expectancy in aggressive water conditions. Please refer to table 1 to clarify how many off peak and on peak immersions are included with the unit you require.

Where it is intended that units are fitted to offpeak circuits, then suitable controllers such as the Horstmann off peak electric time controller will be required. External wiring to the immersion heaters must be in accordance with the relevant IEE Wiring Regulations and the circuit must be protected by a suitable fuse and a double pole isolating switch.

The correct method of terminating the wiring to the immersion heater is shown above.

Usage of the product in non-domestic commercial applications can be extremely intensive and stressful to various components. We recommend that titanium immersion heaters are fitted in such situations, rather than the incolloy heater supplied as standard. Titanium immersion heaters offer superior strength, weight and a smoother finish which enable them to better withstand the extreme stress and temperature fluctuation often encountered within non-domestic environments and situations where water quality is poor – ensuring improved performance and extended operational life.

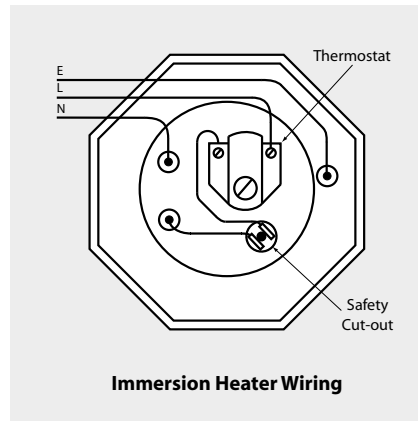

## Line Strainer

This is integral within the combination inlet group to reduce the likelihood of contaminants fouling the valve seat. Following installation this line strainer must be cleaned and replaced. This needs to be carried out on a regular basis, as part of the annual maintenance/service check.

## Tundish

This is to allow the discharge from any Relief Valve to be seen. It must be fitted away from any electrical devices. See page 12 for discharge pipework details.

## Safety

The immersion heaters must be earthed and they must be isolated from the mains before the cover is removed on every occasion. Replacement immersion heaters should be obtained from Viessmann Limited.

## Solar Thermistors / sensors

Care must be taken to ensure that the solar probes are fully inserted into the pockets provided. A fixing clip is supplied.

## Important

Failure to follow the drain down procedure will invalidate the warranty. (see page 20)

- NEVER** drain the cylinder of hot water and then close all cylinder inlets and outlets.
- REASON** as the air remaining in the cylinder cools the pressure inside the cylinder will fall below atmospheric and cause damage to the cylinder.
- NEVER** close the cold main and drain the cylinder via any tap connected to it.
- REASON** as the water drains, the pressure inside the cylinder may decrease below atmospheric and this may cause damage to the cylinder.

In line with good plumbing practice, use of excessive flux should be avoided.

## Gate Valve

All our cylinders are tested to BS EN 12897 at 15 l/min at which they exceed the minimum requirements for heat up performance and reheat in less time than the maximum reheat times.

If a flow rate above 25 l/min is present in the primary cylinder heating circuit, a gate valve can be fitted in this circuit to reduce the flowrate. This may be required if flow noises become apparent.

## Schematic Open Vented Primary System

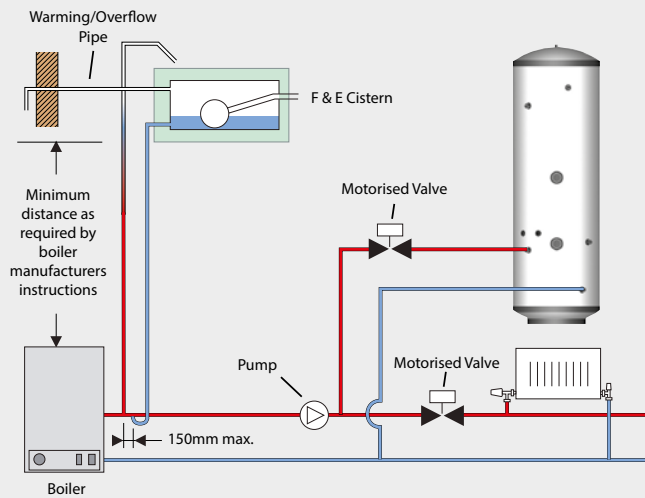

## Heating/primary Systems

The boiler and primary/heating systems should be sized and installed in accordance with BS EN 12828:2003, BS EN 12831:2003 & BS EN 14336:2004.

### Safety

Viessmann Vitocell 200 Cylinder is fitted with a Combined Temperature/Pressure Relief Valve to cope with any increase in system temperature and pressure above the design limitations, when used with boilers up to 45kW output, which is the maximum allowed by section G3 of the Building Regulations. The primary water temperatures should be controlled as outlined below.

### Primary Circuit

The cylinder primary circuit must be pumped. No further controls or safety devices are required for an all-Viessmann installation. Any other make of boiler may require a limit thermostat and 2 port valve to be fitted.

## Schematic Sealed Primary System

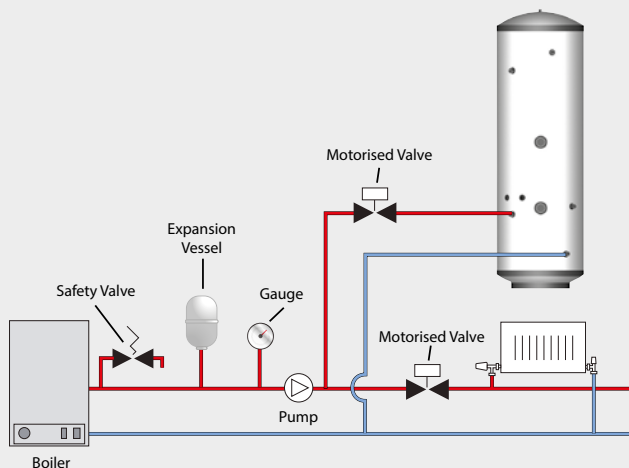

### Sealed Primary Circuit

Any boiler used must be fitted with an over temperature cut-out. Unvented primary circuits may be filled or replenished by means of a temporary connection between the circuit and a supply pipe provided a 'Listed' double check valve or some other no less effective backflow prevention device is permanently connected at the inlet to the circuit and the temporary connection is removed after use. Alternatively, a CA device can be used, which will allow the system to be permanently connected to the cold mains supply. The primary system can then be topped up, when required, in the same way as an open vented system fitted with an F&E Cistern.

# INSTALLATION

## Hydraulic schematics of a Viessmann 4-pipe installation

**Note**

It is recommended that the cylinder coil output is >10 kW to prevent long hot water re-heat periods. Domestic hot water has priority.

Energy cutout devices fitted in the Viessmann boiler

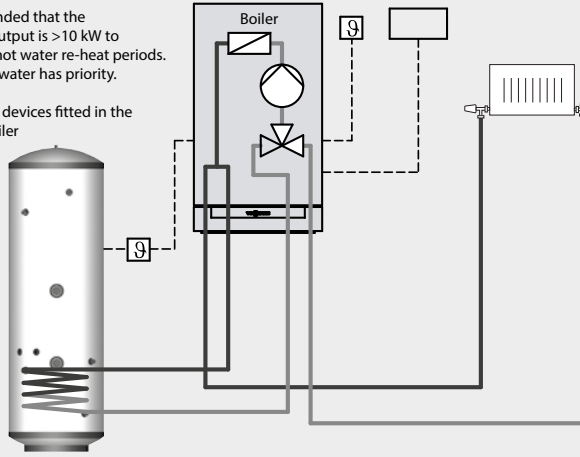

## 4-Pipe System

If the Vitocell 200 is installed with a Viessmann Vitodens condensing system boiler then it is recommended to install the system to a 4-pipe system as shown in the diagram opposite.

Viessmann Vitodens system boilers operate on a sealed primary circuit and are factory fitted with an integral diverter valve, PRV and expansion vessel, and a suitable energy cut-out device to comply with G3 requirements. If any Vitodens system boiler is installed with a Vitocell 200, please use the DHW cylinder sensor (ZK00539).

All Viessmann Vitodens System boilers have an on-board diverter valve and 4-pipe connections. The outer pipes are for the central heating circuit, and the inner pipes are for the cylinder heat exchanger coil circuit. The built-in diverter valve gives domestic hot water priority and may be under the control of a Viessmann cylinder temperature sensor.

If this Viessmann Vitodens System boiler is connected correctly to a Vitocell 200 or 300 unvented water cylinder as a 4 pipe boiler and controlled by a Viessmann cylinder temperature sensor, it does not require additional safety devices such as a cylinder limit thermostat or 2 port valve.

**Note: This does not apply if either the boiler or the cylinder or the controls are exchanged for other makes or models.**

The cylinder temperature sensor connects to red miniature spade terminals numbered 5 on the boiler wiring loom - not the pcb. Look for a coil of wire at the lower rear of a Vitodens 100-W or to the left of the pcb on a Vitodens 200-W. Fixing clips for this and the solar sensor are included.

Gas condensing boiler:

- For Viessmann DHW cylinders: Cylinder temperature sensor (plug on the cable harness outside the control unit)

## Wiring plan for connecting the cylinder temperature sensor to a Viessmann system boiler

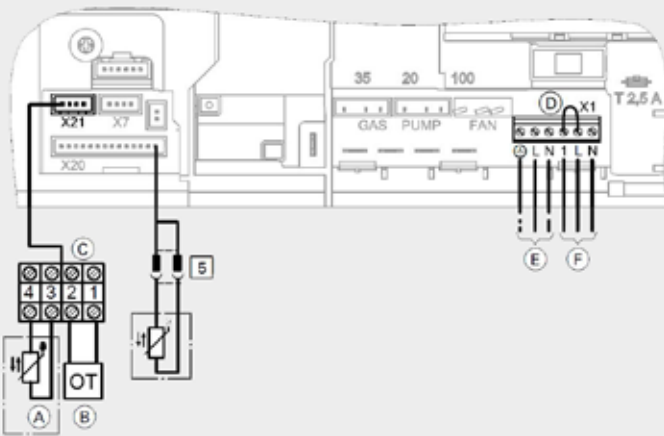

- A Optional outside temperature sensor for weather compensated operation
- B Optional Open Therm device
- C Connecting plug and terminal block
- D Remove the link 1 - L if external mains voltage switching is required for central heating control
- E Mains power connecting lead into the boiler
- F Connection for external mains voltage switching for central heating control
- 5 Connection for cylinder temperature sensor





# INSTALLATION

**Figure 1: Cold port of the blending valve connected to mains supply NOT ALLOWED**

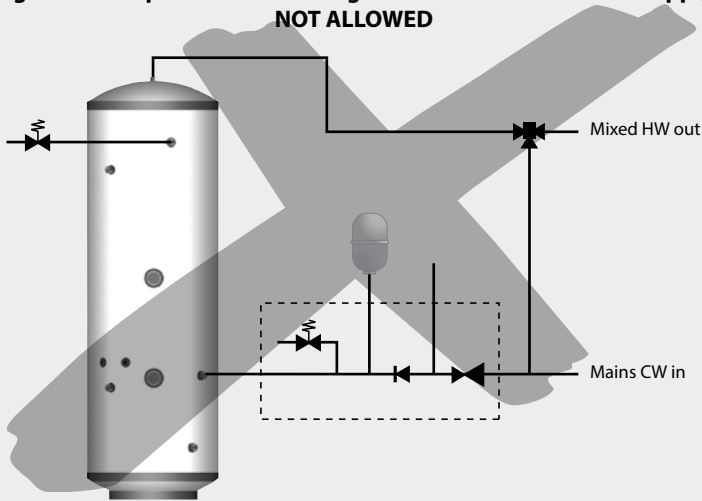

**Figure 2: Cold port of the blending valve connected to balanced cold supply - NON-RETURN VALVE MUST BE FITTED**

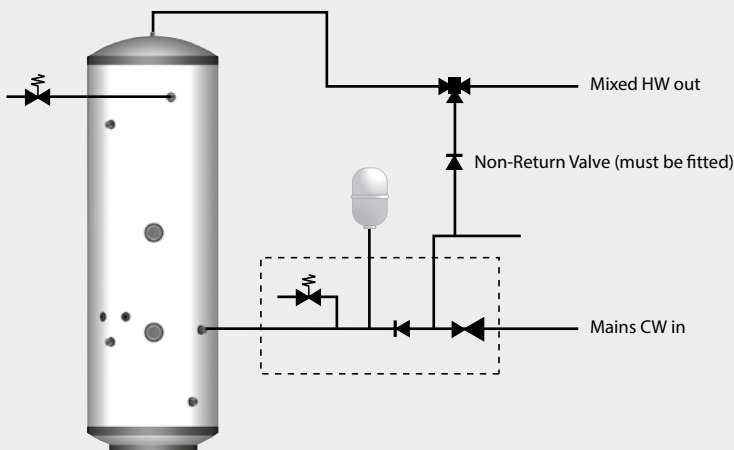

**Figure 3: Cold port of the blending valve connected to mains supply to the vessel after the inlet control group**

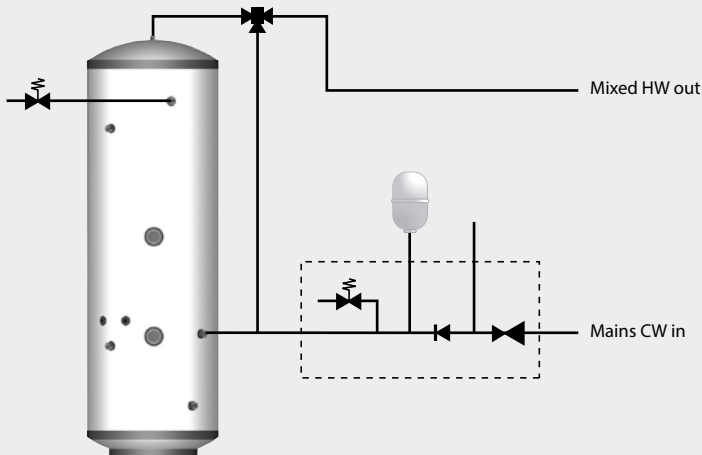

## Fitting Blending Valves To The Unvented Viessmann Vitocell Appliances

When fitting a blending valve to the unvented appliances, it is important that the installation does not contravene the G3, WRC and Health and Safety directives or the manufacturers recommendations. If this is the case, then the warranty should be null & void. The key requirements to comply with these regulations are: -

1. Any fitting or material in contact with potable water (e.g. a blending valve) must be approved by WRC or an equivalent body.
2. Connections or wiring arrangements must not bypass any safety devices.
3. Any expansion due to heating must not be allowed to expand back into the cold mains.
4. The settings of any safety devices must not be tampered with or adjusted.

The diagrams opposite shows how the blending valve can be piped onsite.

Figure 1 shows the cold water port of the blending valve connected to the mains cold water supply before the inlet control group. This arrangement is completely unacceptable and illegal because: -

- the water is allowed to expand in to mains cold water supply.
- the vessel will be charged to the incoming mains supply which may be considerably higher than the working pressure of the vessel.

If this arrangement is used then the warranty will not be valid.

Figure 2 shows the cold water port of the blending valve connected to the balanced cold water outlet. This arrangement will only be acceptable if a WRAS approved non-return valve is fitted, otherwise: -

- during the heating cycle, the water will expand back into the mains supply, as the regulating valve must not be relied upon to act as a check valve under all operating conditions.
- depending upon the characteristics of the blending valve, hot water may also flow from the balanced cold water taps.

Figure 3 shows the cold port of the blending valve connected to the cold water supply to the vessel after the inlet control group. This should be the preferred method. It is recommended that the installer should ensure that there is no gravity circulation in the pipework connected to the cold port. If necessary, this can be achieved by fitting a non-return valve or using a thermal trap.

# INSTALLATION

Schematic Showing Solar Wiring Requirements

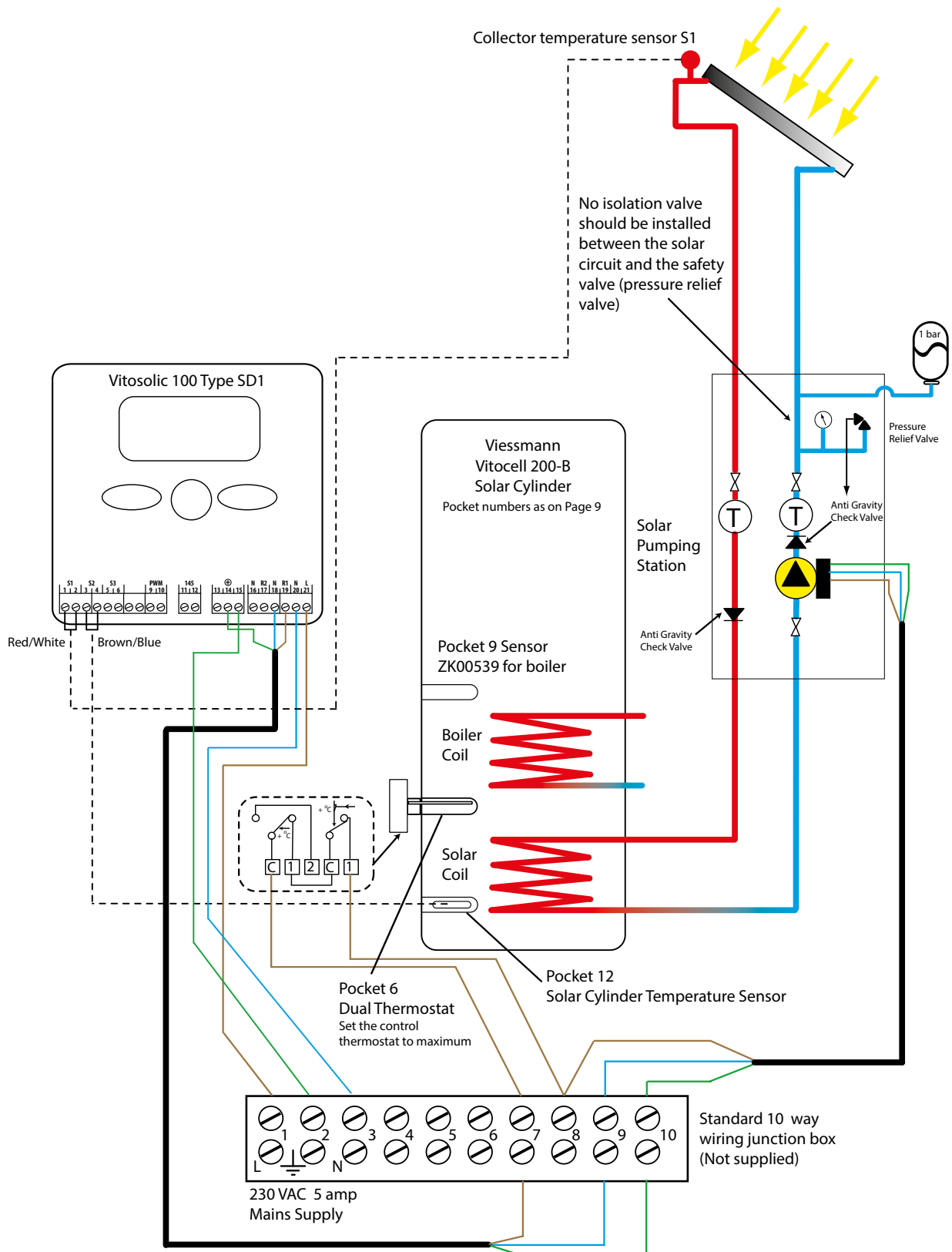

INSTALLATION

# INSTALLATION

## Commissioning

Connections can come loose in transit, and all should be checked before installation.

The 90 degree elbow fitted on the hot draw off needs to be positioned and tightened by installer.

The control thermostat of the immersion heaters for direct heating of our cylinders are set at 60°C. The control thermostat for indirect heat exchanger heat up of our cylinders are usually set at between 60°C - 65°C. During commissioning the actual temperature that the cylinder reaches when the thermostat(s) operate should be tested and adjusted so that it achieves a minimum of 60°C. This temperature needs to be achieved on a regular basis.

Check the pressure on the air side of the expansion vessel = 3 bar. This must be done when the water in the cylinder is free to expand in atmospheric pressure or the cylinder and relevant pipe work is empty.

Check that the drain cock is closed, and open all the cold and hot water taps and other terminal fittings. Allow the system to fill with water, and to run until there is no air left in the system. Close the taps and inspect the system closely for leaks.

Manually open the Relief Valves one by one and check that water is discharged and run freely through the tundish and out at the discharge point. The pipework should accept full bore discharge without overflowing at the tundish, and the valve should seat satisfactorily.

In line with good plumbing practice, use with excessive flux should be avoided. When soldering above the cylinder, ensure flux/solder does not contaminate the cylinder below, since this can cause corrosion. Flushing should be done performed as per BS EN 806:4 2010 section 6.2.

Allow the cylinder to heat to normal working temperature, then thoroughly flush the domestic hot and cold water pipework through each tap.

**NOTE:** If this appliance is to be installed in other than a single domestic dwelling ie. in an apartment block or student flats etc., the hot and cold water system will need to be disinfected in accordance with BS EN 806:4 2010 section 6.3 and the Water Regulations.

Because the Viessmann appliance is stainless steel, the use of chlorine as the disinfection agent can cause damage unless the appliance is adequately flushed and refilled with the mains water immediately on completion of the disinfection procedure.

Damage caused through a failure to do this adequately will not be covered by the warranty.

For the above reasons we recommend the use of a non chlorine based disinfectant such as Fernox LP Sterox as manufactured by Cookson Electronics when carrying out disinfection of systems incorporating these appliances.

Remove the filter from the combination inlet group clean and replace. Refill the system and open all hot taps until there is no air in the pipe work. **ENSURE CYLINDER IS DRAINED PRIOR TO CHECKING OR REMOVING FILTER FROM THE COMBINATION INLET GROUP.**

Allow the cylinder to heat to normal working temperature with whatever heat source is to be used, and check again for leaks. The pressure relief valve or the P&T valve should not operate during the heating cycle. If the P&T valve operates before the pressure relief valve due to high pressure, check that the inlet control group is fitted correctly.

The boiler/heating systems should be filled and commissioned in accordance with good practice following the guidance in BS 7593:2006/the boiler manufacturers instructions.

## NOTE

At the time of commissioning, complete all relevant sections of the Benchmark Checklist located on the inside back pages of this document.

This must be completed during commissioning and left with the product to meet the warranty conditions.

## IMPORTANT - DRAIN DOWN PROCEDURE

- 1 Switch off both the boiler and the immersion heater
- 2 Open the nearest hot tap and run all hot water until cold, then close it
- 3 Close the incoming cold main at the stop tap
- 4 **Hold open the pressure and temperature relief valve until water stops discharging into the tundish and leave it open**
- 5 Open the cold taps starting from the highest point and working down to the lowest tap, leaving them open
- 6 When the cold taps have stopped draining, open the hot taps starting from the highest and working down to the lowest tap
- 7 Open the drain cock and ensure the pressure and temperature relief valve is held open until the cylinder is empty

# USER INSTRUCTIONS

## User Instructions

Your Viessmann Vitocell 200 Cylinder is automatic in normal use, but requires routine maintenance which is normally carried out at least annually along with the boiler service. The maintenance must be carried out by a suitably competent tradesperson who is qualified to work on unvented cylinders. The checks/work needed are listed in the maintenance part of these Instructions.

The control thermostat of the immersion heaters for direct heating of our cylinders are set at 60°C. The control thermostat for indirect heat exchanger heat up of our cylinders are usually set at between 60°C - 65°C. During commissioning the actual temperature that the cylinder reaches when the thermostat(s) operate should be tested and adjusted so that it achieves a minimum of 60°C, in order to comply with the Legionella pasteurisation requirements.

When initially opening the taps, a small surge in flow may be experienced, which disappears as the pressure in the system stabilises. This is quite normal with these types of systems and does not indicate a fault.

In some areas the water will initially appear cloudy, but will quickly clear when left to stand. This is nothing to be concerned about and is due to aeration of the water.

**WARNING** - If water is seen flowing through the tundish, this indicates a fault condition which needs action.

If the discharge is hot and continuous, turn the boiler and/or the immersion heaters off, but do not turn off the cold water to the appliance until the discharge is cold.

**Note:** The discharge may stop by itself as the discharge cools.

If the discharge is cold and intermittent, no immediate action is needed but this indicates a problem with the expansion vessel.

**However, in both cases you must call the Registered Installer / a suitably qualified, competent tradesperson, advise them that you have an unvented cylinder and request a maintenance visit.**

**DO NOT**, at any time, tamper in any way with the safety valves or overheat thermostats/wiring.

# SERVICING

## Maintenance

The Registered Installer is responsible for the safe installation and operation of the system. The installer must also make his customer aware that periodic maintenance of the equipment is essential for safety.

Maintenance periods will vary for many reasons. Viessmann Ltd recommend a maximum of 12 months to coincide with boiler maintenance. Experience of local water conditions may indicate that more frequent maintenance is desirable, eg, when water is particularly hard, scale-forming or where the water supply contains a high proportion of solids, eg, sand. Maintenance must include the following:

1. Check and clean filter
2. Manually check the operation of the temperature relief valve.
3. Manually check the operation of the expansion relief valve.
4. Check discharge pipes from temperature and expansion relief valves are free from obstruction and blockage and are not passing any water.
5. Check the condition and if necessary descale the heat exchangers in hard water areas.
6. Check that water pressure downstream of pressure reducing valve is within the manufacturer's limits.
7. Check operation of motorised valve.
8. Check the pressure on the air side of the expansion vessel. This must be done when the water in the cylinder is cold.
9. Check and advise the householder not to place any clothing or other combustible materials against or on top of this appliance.
10. On completion of the work, fill in the Service Record part of the Benchmark section of the manual.

### IMPORTANT NOTE

**When draining down the appliance for any reason, the instructions provided in the Commissioning Section (Page 20) MUST be followed to prevent potential damage to the cylinder.**

When carrying out the annual service on the appliance/boiler, it is recommended that with solar appliances, a check is made of the solar system pressure/expansion vessel charge pressure along with a visual check of the solar panels.

It is recommended that after a maximum of five years, the concentration/quality of the solar system antifreeze solution is checked and, if necessary, replaced.

After servicing, complete the relevant Service Interval Record section of the Benchmark Checklist located on the inside back pages of this document.

## Problems And Remedial Action

### Scale

In hard water areas it is recommended that an in-line scale inhibitor is fitted. Reducing the temperature of the stored water will reduce the rate at which scale forms. If the recovery rate is badly affected, this is an indication that scaling may have occurred. In this event, follow the procedures as recommended by a reputable Water Treatment Company.

### General

No water at the tap. Check that the mains water supply is turned ON. Check the line strainer is not blocked. Check that the combination valve has been fitted so that water is flowing in the correct direction.

If the water at the tap is cold, ensure that the boiler has been switched ON and is working correctly. Check that there are no air locks in the primary system. ISOLATE THE UNIT AT THE MAINS ELECTRIC SUPPLY AND THEN CHECK THE FOLLOWING:

- i. The cylinder thermostat
- ii. The thermal cut-out, which can be re-set by pushing the red button
- iii. The motorised valve
- iv. The boiler thermostat
- v. The boiler thermostat cut-out (if fitted)

ANY ENERGY CUT-OUT MUST NEVER BE BY-PASSED UNDER ANY CIRCUMSTANCES.

If the units are not getting hot and the heat source is electrical, ensure that the immersion heaters are isolated from the mains before re-setting the energy cut-out. If the immersion heater(s) need replacing this should be done with the units supplied from Viessmann Limited.

### Discharge From Relief Valves

If cold water is discharging from the expansion relief valve into the tundish check the pressure on the expansion vessel when cold and recharge if necessary.

If the fault continues and the problem cannot be stopped by operating the easing control a few times then either the Pressure Reducing Valve or the Relief Valve may be at fault. If the cold water pressure is too high, this would suggest that the Pressure Reducing Valve is at fault and the Viessmann approved replacement should be fitted. If the pressure is correct then the Relief Valve will require replacing with a Viessmann approved component.

### See Commissioning for drain down procedure.

If there is an overheat fault and very hot water is being discharged, turn off the heat source, **but not the water supply**.

When the supply is cool, check thermostats and energy cut-outs in the boiler and immersion heaters and replace the faulty component with a unit supplied by Viessmann and check that it works correctly before returning the system to full operation.

# SERVICING

## Fault - No Hot Water

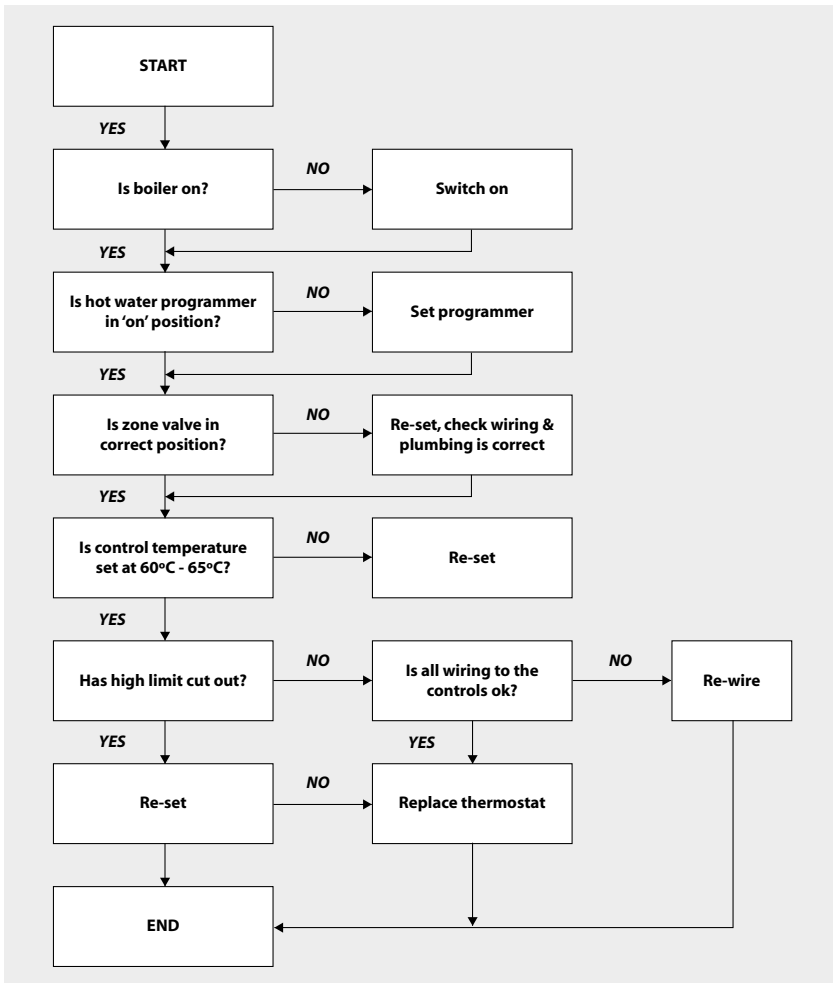



# SERVICING

**Fault - Poor Water Flow At Hot Taps**

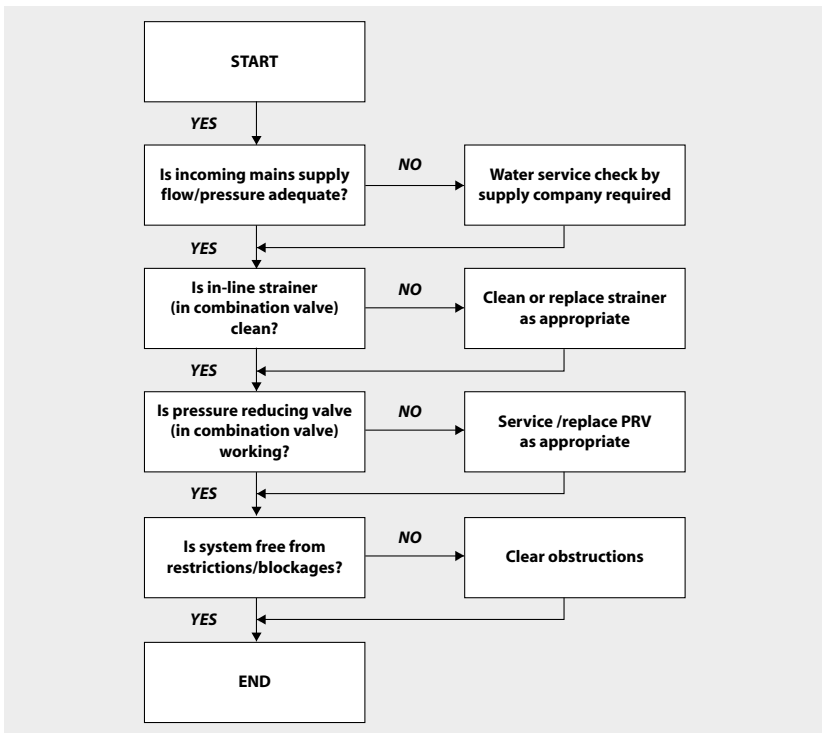

**Fault - Water Discharge Into Tundish**

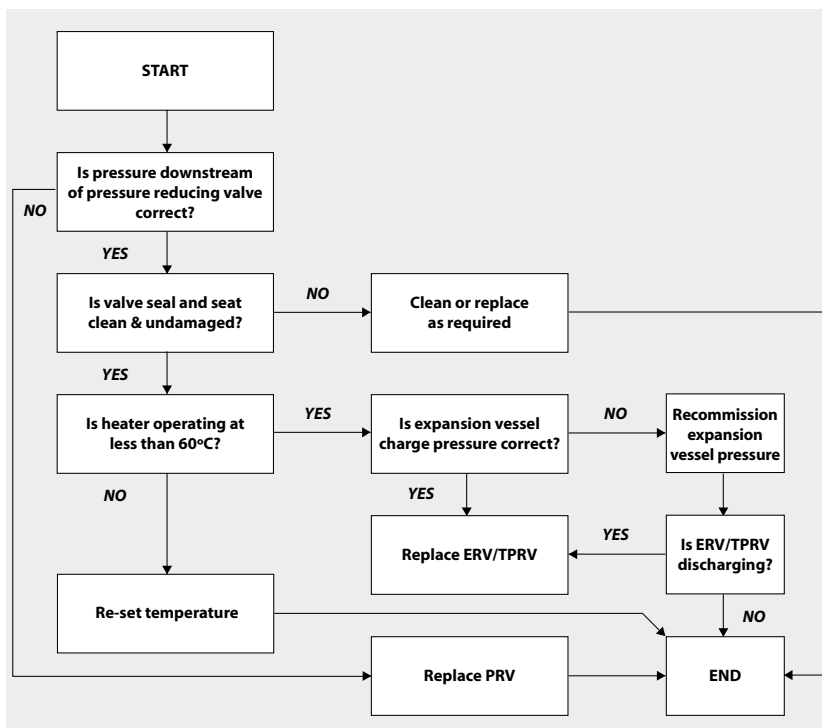

# SERVICING

SPARE PARTS LIST				
	Description	Quantity	Gledhill Code No.	Spares Part No.
1	3kW immersion element	1	SH001	7160753
2	22mm 90° compression elbow c/w/drain	1	SF003	7160754
3	Pressure and temperature relief valve 6 bar 92-95°C	1	SG019	
4	Inlet group set at 3 bar c/w expansion relief valve set at 4.5 bar	1	SG021	
5	¾" flexible hose	1	SG024	
7	12 litre expansion vessel	1	XG190	
8	18 litre expansion vessel	1	XG191	
9	24 litre expansion vessel	1	XG192	
10	35 litre expansion vessel	1	XG193	
11	Wall mounting bracket for 35 litre expansion vessel	1	XG058	
12	22mm 2 port valve / Control and overheat limit thermostat	1	EX042	7663214
13	Junction wiring box (12 way)	1	XG129	7160765
14	15mm x 22mm tundish	1	XG207	
15	Cylinder temperature sensor and retaining clip (ZK00539)	1	GT530	

## Water Savings

### Water Related Costs Can Be Reduced By Good Plumbing Practice

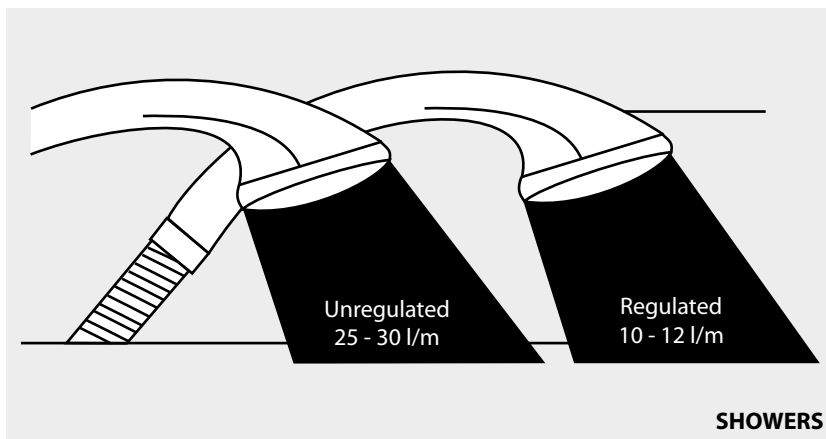
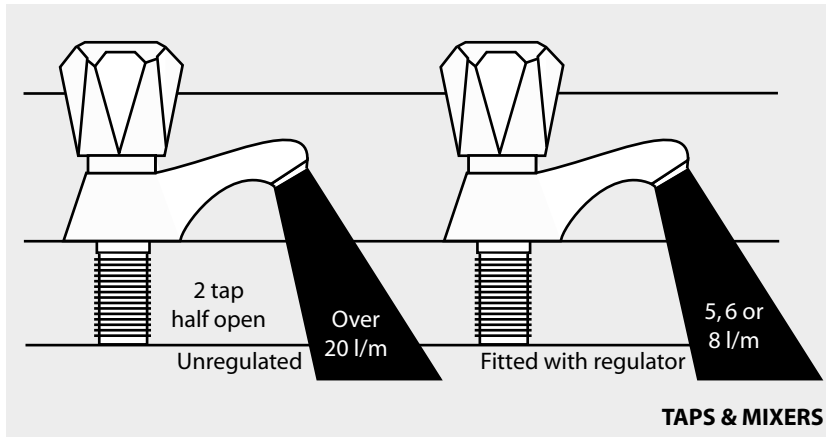

Vast quantities of water are needlessly run off to waste due to Taps, Mixers and Showers discharging flow rates far in excess of the rates required for them to perform their duties.

The contrasting flow rates shown on this leaflet clearly illustrate the savings that can be made whilst still providing a good performance.

British made Aquaflow Regulators provide constant flow rates by automatically compensating for supply pressure changes between 1 bar & 10 bars.

To facilitate installation into the wide range of plumbing equipment which is encountered in the U.K, Four Fixing Options are available:-

#### Options For Showers

1. MXF "DW" Range - For fitting behind Fixed Shower Heads or onto Flexible Hoses for Handshowers (preferably onto the inlet end when lightweight hoses are used).
2. Compression Fitting Range. "In Line" regulators as in Option 4 for Taps & Mixers.

Information by courtesy of

#### AQUAFLOW REGULATORS LTD

Haywood House, 40 New Road, Stourbridge, West Midlands DY8 1PA  
TELEPHONE (01384) 442611 FAX: (01384) 442612

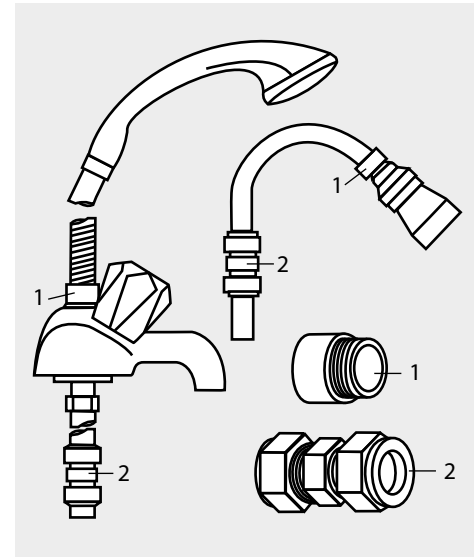

#### 4 Fixing Options For Taps & Mixers

1. MK Range - Combined Regulators & Aerators for screwing onto Taps & Mixers with internal or external threads on their noses. Anti Vandal models also available.
2. MR05-T Range - Internal Regulators. Push-fit into Tap or Mixer seats. Produced in three sizes - 12.5mm (BS1010), 12mm & 10mm, Flangeless models also available for Taps with Low Lift washers.
3. MXF Standard Range - Screw on tail models for Taps & Mixers. Fix onto the tails before fitting the tap connectors. Available in 3/8", 1/2", 3/4" and 1" BSP.
4. Compression Fitting Range - "In Line" regulators housed in 15mm & 22mm CXC Couplers & Isolating Valves. "UKWFB" listed by the Water Research Centre. Isolation valves available for slotted screwdriver operation or with coloured plastic handles. Now available also in plastic bodied push-fit couplers & valves.

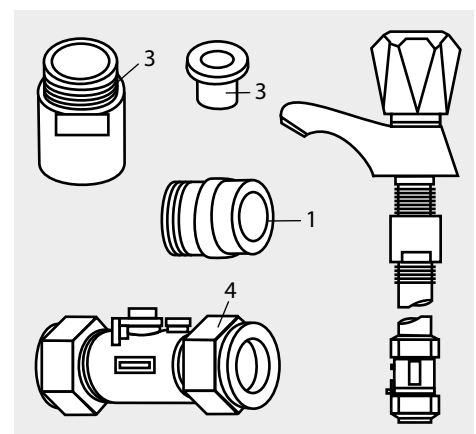

## **MANUAL HANDLING OF APPLIANCE PRODUCTS**

### **Description**

Manual handling means any transporting or supporting of a load (including lifting, putting down, pushing, pulling, carrying or moving) by hand or bodily force.

### **Scope**

This assessment will cover the largest unit within each product range.

For specific weights and dimensions please refer to technical data section.

### **Main Hazards**

Vision may not be clear due to the size of the products.

Adopting an incorrect method of lifting may cause injury, attempting to lift these products will require help from others. (Team lifts)

### **Control Measures**

#### **Manual lifting procedure**

The lift, key factors in safe lifting are:

- a. **Balance**
- b. **Position of back**
- c. **Positioning of the arms and body**
- d. **The hold**
- e. **Taking the lead for team lifts**

a. **Balance** - Since balance depends essentially upon the position of the feet, they should be apart about hip breadth with one foot advanced giving full balance sideways and forward without tension. In taking up this position, lifting is done by bending at the knees instead of the hips and the muscles that are brought into use are those of the thigh and not the back.

b. **Position of back** - Straight - not necessary vertical. The spine must be kept rigid, this coupled with a bent knee position, allows the centre line of gravity of the body to be over the weight so reducing strain.

c. **Positioning of arms and body** - The further arms are away from the side, the greater the strain on the shoulders, chest and back. Keep elbows close to the body arms should be straight.

d. **The hold** - Before lifting ensure you have a good hold.

e. **Taking the lead for team lifts**- As more than one person is required for these products ensure that one person is taking the lead. **This may be you** so ensure that each person that is helping is made aware of the weight and of the items listed within this assessment. Make sure you and any others helping know the route you intend to take that it is clear of any obstructions. Never jerk the load as this will add a little extra force and can cause severe strain to the arms, back and shoulders. If there are steps involved decide on where you will stop and take a rest period. Move smoothly and in unison taking care to look and listen to others helping with the lift. Where possible use a sack truck to move the product over long flat distances, only lift the products when necessary. If in doubt stop and get more help.

#### **Individual capability**

Individual capability plays an important part in handling these products. Persons above average build and strength will find it easier and should be in good health. Persons below average build and strength may require more rest periods during the handling process.

Pregnant women should not carry out this operation.

Persons who are not in good health should seek medical advice prior to commencing any lifting or manual handling operation.

#### **Residual risk**

Following the guidelines given above will reduce any risk to injury.

All persons carrying out this operation must be fully trained and copies of the specific risk assessment made available for inspection and use in their training process.

Further guidance on Manual Handling can be obtained from the Health and Safety Executive. Manual Handling Operations Regulations 1992.



# BENCHMARK

## MAINS PRESSURE HOT WATER STORAGE SYSTEM COMMISSIONING CHECKLIST

This Commissioning Checklist is to be completed in full by the competent person who commissioned the storage system as a means of demonstrating compliance with the appropriate Building Regulations and then handed to the customer to keep for future reference.

Failure to install and commission this equipment to the manufacturer's instructions may invalidate the warranty but does not affect statutory rights.

Customer name:										Telephone number:														
Address:																								
Cylinder Make and Model																								
Cylinder Serial Number																								
Commissioned by (PRINT NAME):										Registered Operative ID Number														
Company name:										Telephone number:														
Company address:																								
										Commissioning date:														
To be completed by the customer on receipt of a Building Regulations Compliance Certificate*:																								
Building Regulations Notification Number (if applicable)																								
<b>ALL SYSTEMS PRIMARY SETTINGS</b> (indirect heating only)																								
Is the primary circuit a sealed or open vented system?										Sealed					Open									
What is the maximum primary flow temperature?															°C									
<b>ALL SYSTEMS</b>																								
What is the incoming static cold water pressure at the inlet to the system?															bar									
Has a strainer been cleaned of installation debris (if fitted)?										Yes					No									
Is the installation in a hard water area (above 200ppm)?										Yes					No									
If yes, has a water scale reducer been fitted?										Yes					No									
What type of scale reducer has been fitted?																								
What is the hot water thermostat set temperature?															°C									
What is the maximum hot water flow rate at set thermostat temperature (measured at high flow outlet)?															l/min									
Time and temperature controls have been fitted in compliance with Part L of the Building Regulations?										Yes														
Type of control system (if applicable)										Y Plan					S Plan					Other				
Is the cylinder solar (or other renewable) compatible?										Yes					No									
What is the hot water temperature at the nearest outlet?															°C									
All appropriate pipes have been insulated up to 1 metre or the point where they become concealed										Yes														
<b>UNVENTED SYSTEMS ONLY</b>																								
Where is the pressure reducing valve situated (if fitted)?																								
What is the pressure reducing valve setting?															bar									
Has a combined temperature and pressure relief valve and expansion valve been fitted and discharge tested?										Yes					No									
The tundish and discharge pipework have been connected and terminated to Part G of the Building Regulations										Yes														
Are all energy sources fitted with a cut out device?										Yes					No									
Has the expansion vessel or internal air space been checked?										Yes					No									
<b>THERMAL STORES ONLY</b>																								
What store temperature is achievable?															°C									
What is the maximum hot water temperature?															°C									
<b>ALL INSTALLATIONS</b>																								
The hot water system complies with the appropriate Building Regulations										Yes														
The system has been installed and commissioned in accordance with the manufacturer's instructions										Yes														
The system controls have been demonstrated to and understood by the customer										Yes														
The manufacturer's literature, including Benchmark Checklist and Service Record, has been explained and left with the customer										Yes														
Commissioning Engineer's Signature																								
Customer's Signature																								
(To confirm satisfactory demonstration and receipt of manufacturer's literature)																								

\*All installations in England and Wales must be notified to Local Authority Building Control (LABC) either directly or through a Competent Persons Scheme. A Building Regulations Compliance Certificate will then be issued to the customer.



© Heating and Hotwater Industry Council (HHIC)

www.centralheating.co.uk

While this Checklist can be used for any installation covered by its description, only appliances manufactured by Scheme Members will be covered by the rules and requirements of the Benchmark Scheme.

## SERVICE RECORD

It is recommended that your hot water system is serviced regularly and that the appropriate Service Record is completed.

### Service Provider

Before completing the appropriate Service Record below, please ensure you have carried out the service as described in the manufacturer's instructions.

<b>SERVICE 01</b>	Date:	<b>SERVICE 02</b>	Date:
Engineer name:		Engineer name:	
Company name:		Company name:	
Telephone No:		Telephone No:	
Comments:		Comments:	
Signature		Signature	
<b>SERVICE 03</b>	Date:	<b>SERVICE 04</b>	Date:
Engineer name:		Engineer name:	
Company name:		Company name:	
Telephone No:		Telephone No:	
Comments:		Comments:	
Signature		Signature	
<b>SERVICE 05</b>	Date:	<b>SERVICE 06</b>	Date:
Engineer name:		Engineer name:	
Company name:		Company name:	
Telephone No:		Telephone No:	
Comments:		Comments:	
Signature		Signature	
<b>SERVICE 07</b>	Date:	<b>SERVICE 08</b>	Date:
Engineer name:		Engineer name:	
Company name:		Company name:	
Telephone No:		Telephone No:	
Comments:		Comments:	
Signature		Signature	
<b>SERVICE 09</b>	Date:	<b>SERVICE 10</b>	Date:
Engineer name:		Engineer name:	
Company name:		Company name:	
Telephone No:		Telephone No:	
Comments:		Comments:	
Signature		Signature	

**WRAS**  
APPROVED  
PRODUCT



Viessmann Werke GmbH&Co KG  
D-35107 Allendorf  
Telephone: +49 6452 70-0  
Fax: +49 6452 70-2780  
[www.viessmann.com](http://www.viessmann.com)

Viessmann Limited  
Hortonwood 30, Telford  
Shropshire, TF1 7YP, GB  
Telephone: +44 1952 675000  
Fax: +44 1952 675040  
E-mail: [info-uk@viessmann.com](mailto:info-uk@viessmann.com)